



INSTRUCTIONS

GEI-98350C

SUPERSEDES GEI-98350

HARMONIC RESTRAINT OVERCURRENT RELAY



Type BFC11A

GENERAL  ELECTRIC

GEI-98350 Harmonic Restraint Overcurrent Relay Type BFC11A

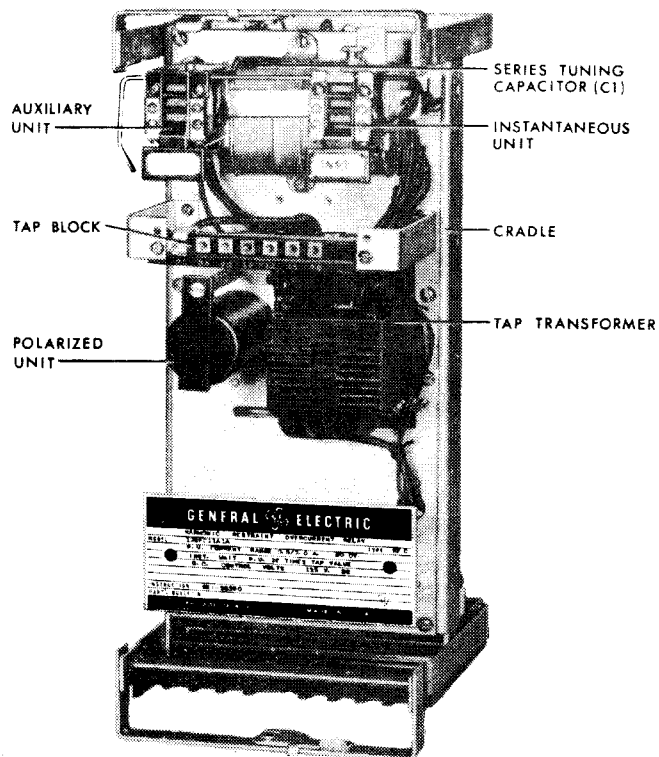

Cover (8035561)

Fig. 1 (8035562) Type BFC Relay, Removed From Case, Front View.

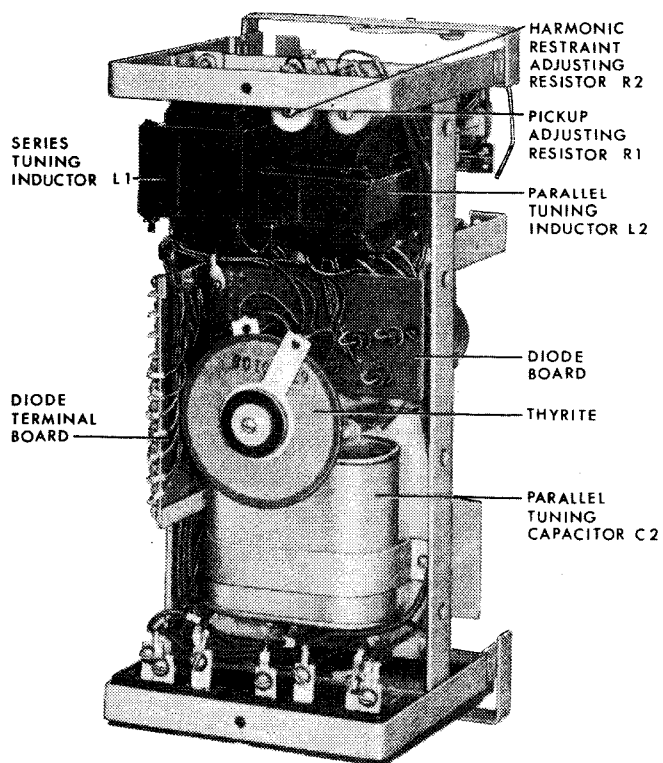

Fig. 2 (8035560) Type BFC Relay, Removed From Case, Rear View.

HARMONIC RESTRAINT OVERCURRENT RELAY TYPE BFC11A

INTRODUCTION

The type BFC relay is an instantaneous over-current relay with harmonic restraint.

The relay consists of three units: a sensitive polarized unit, an auxiliary unit similar to the familiar target-seal-in unit, and a hinged armature instantaneous unit. All units are mounted in the M1 (medium size single ended) drawout case.

APPLICATION

The BFC relay may be used to supervise ground relays (or even phase relays) which may operate on inrush current. A typical consideration involves energizing a line which has one or more transformers connected to it. Inrush current to the transformer or transformers may cause ground relays to operate at the terminal used to energize the line. The use of a BFC relay connected as shown in Figure 5 to supervise the ground relays will prevent undesired tripping of the line breaker.

* The BFC relay is available in two ranges, (.5-2) amperes and (4-16) amperes.

The (hinged armature) instantaneous unit of the BFC relay picks up at approximately 26 times the tap setting of the main unit. This unit assures correct relay operation during heavy faults when possible CT and relay transformer saturation might generate harmonics which would cause false relay restraint.

Calculations

- A. When used to supervise ground relays, a tap (pickup) should be chosen for the BFC relay which is 80% or less of the lowest ground relay pickup value to be supervised. The (hinged armature) instantaneous unit in the BFC relay is set to pick up at approximately 26 times tap value. In choosing the desired tap setting a check should be made to determine that the instantaneous unit does not pick up on transformer inrush current.
- B. For a fault equal to the instantaneous unit setting the current transformer error current must be less than 20%.

RATINGS

*Current Circuit

The rating of the current circuit is given below:

Pickup range	0.5/2	4/16
Continuous current	5	10**
One second rating	260	350
(One second rating) ²	67,600	122,100

**Continuous current rating is tap value for the 12 and 16 amp taps.

Higher current may be applied for short lengths of time in accordance with the following equation:

$$I^2t = 67,600 \text{ for } 0.5/2 \text{ rating or}$$

$$I^2t = 122,000 \text{ for } 4/16 \text{ rating}$$

Where: I = Current in amperes
t = Time in seconds

Auxiliary Relay Control Circuit

* The BFC relay is available with 48, 125, or 250 volts dc control voltage.

Contacts

The auxiliary and instantaneous unit contacts will make & carry 30 amperes for tripping duty for voltages not exceeding 250 volts. If more than one circuit breaker per set of contacts is to be tripped or if the tripping current exceeds 30 amperes, an auxiliary relay must be used. After tripping occurs it is necessary that the tripping circuit of these relays be opened by an auxiliary switch on the circuit breaker or by other automatic means.

Pickup Range

The relay is provided with taps to allow pickup values of the main unit of 0.5, 0.6, 0.8, 1.0, 1.2, 1.5, 2.0 amperes, for the 0.5-2.0 ampere relay. The 4-16 ampere relay has taps of 4, 5, 6, 7, 8, 10, 12, & 16 amperes. The instantaneous unit has been adjusted at the factory to pickup at 26 times the tap setting of the main unit.

These instructions do not purport to cover all details or variations in equipment nor to provide for every possible contingency to be met in connection with installation, operation or maintenance. Should further information be desired or should particular problems arise which are not covered sufficiently for the purchaser's purposes, the matter should be referred to the General Electric Company.

To the extent required the products described herein meet applicable ANSI, IEEE and NEMA standards; but no such assurance is given with respect to local codes and ordinances because they vary greatly.

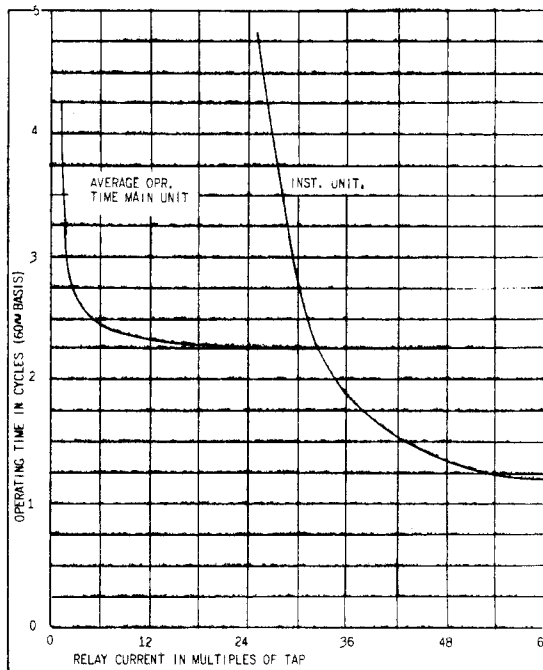

Fig. 3 (0178A7337-0) Operating Time Characteristic Of The Type BFC Relay.

CHARACTERISTICS

Pickup & Operating Time

The relay will pickup at tap value $\pm 10\%$. The operating times of the main unit & instantaneous unit are shown in Figure 3.

Tap Transformer Circuit

The tap transformer secondary output supplies the instantaneous unit directly, the operating coil of the polarized unit through a series tuned circuit, and the harmonic restraint circuit through a parallel resonant trap. The operating and restraint currents are each passed through a full wave bridge rectifier before passing through the polarized unit coils.

The series resonant circuit is made up of a 5 microfarad capacitor (C1) & a reactor (L1) which are tuned to pass currents of the fundamental system frequency and to offer high impedance to currents of other frequencies. Resistor R1 is connected in parallel on the d-c side of the operate rectifier & can be adjusted to give the desired amount of operate current. The output of the rectifier is applied to the operating coil of the polarized unit.

The parallel resonant trap is made up of a 15 microfarad capacitor (C1) & a reactor (L1) which are tuned to block fundamental frequency currents while allowing currents of harmonic frequencies to pass with relatively little impedance. Resistor R2 is connected in parallel on the a-c side of the harmonic restraint rectifier & can be adjusted to give the desired amount of harmonic

restraint. The output of the rectifier is applied to the restraint coil of the polarized unit.

Thus, the fundamental component of the applied current will flow, mostly in the operating coil circuit & cause the relay to operate. If, however, the applied current contains a certain percentage of harmonics, the relay will be restrained from operating by the harmonic currents flowing in the restraint coil.

A Thyrite* resistor connected across the secondary of the tap transformer limits any transient high voltage peaks which may occur, thus protecting the rectifiers & capacitors from damage without materially affecting the characteristics of the relay.

Harmonic Restraint Characteristics

At the time a power transformer is energized, current is supplied to the primary which establishes the required flux in the core. This current is called magnetizing inrush, and appears as shown in Figure 6. This current can cause instantaneous overcurrent relays (phase or ground) to operate falsely. The BFC relay is specifically designed to supervise such relays to prevent such operation.

Power system fault currents are of a nearly pure sine waveform plus a d-c transient component. The sine waveform results from sinusoidal voltage generation and nearly constant circuit impedance. The d-c component depends on the time in the voltage cycle at which the fault occurs and upon the circuit impedance magnitude and angle.

*Registered T.M. of the General Electric Co.

CONSTRUCTION

Figures 1 & 2 show the internal arrangement of the components of the BFC relay. Reference to the internal connection diagram Figure 4 will also aid in identifying the various components.

Overcurrent Unit

The instantaneous unit is a hinged armature relay with a self contained target indicator. On extremely heavy fault currents this unit will pickup & complete the trip circuit. It's target will be exposed to indicate tripping was through the instantaneous unit.

Because of saturation of the CT's & tap transformer at high fault currents it may be possible for harmonics to be generated which would falsely restrain the relay. Tripping is assured, however, by operation of the overcurrent unit. Figure 3 shows the relative levels of pickup & speed of operation of the main unit & the overcurrent unit.

Main Operating Unit

The main operating unit of the type BFC relay is a sensitive polarized unit with components as shown within the large circle as shown in the internal connection diagram (Figure 4). The unit is a high speed low energy device, and its contacts operate an auxiliary unit whose contacts are brought out to studs for connection in an external circuit.

The polarized unit is mounted on an eight prong base which fits a standard octal radio socket, and is protected by a removable dustcover.

The auxiliary unit carries an indicating target & is located on the left hand side (front view) of the relay. The coil of this unit is connected to the d-c control bus through an open contact of the polarized relay and through a series resistor.

The coil of the auxiliary unit is controlled by both the open & closed contacts of the polarized unit. The polarized unit has approximately 0.005 inch contact gap which, under transient d-c overvoltage conditions could arc over. This will not cause false operation because the auxiliary relay coil is normally short-circuited by the closed contact of the polarized unit & the series resistance is high enough to cause the arc to go out at normal voltage.

Case

The case is suitable for surface or semiflush panel mounting and an assortment of hardware is provided for either method. The cover attaches to the case and carries the target reset mechanism for the trip indicator and instantaneous unit. Each cover screw has provision for a sealing wire.

The case has studs or screw connections at the bottom for the external connections. The electrical connections between the relay unit and the case

Transformer magnetizing inrush currents vary according to the extremely variable exciting impedance resulting from core saturation. They are often of high magnitude, occasionally having an RMS value with 100 percent offset approaching 16 times full load current for worst conditions of power transformer residual flux and point of circuit closure on the voltage wave. They have a very distorted waveform made up of sharply peaked half-cycle loops of current on one side of the zero axis, and practically no current during the opposite half cycles. The two current waves are illustrated in * Fig. 6.

Any current of distorted, nonsinusoidal waveforms may be considered as being composed of a direct-current component plus a number of sine-wave components of different frequencies; one of the fundamental system frequency and the others, called "harmonics" having frequencies which are 2, 3, 4, 5, etc., times the fundamental frequency. The relative magnitudes and phase positions of the harmonics with reference to the fundamental determine the wave-form. When analyzed in this manner the typical fault current wave is found to contain only a very small percentage of harmonics while the typical magnetizing inrush wave contains a considerable amount.

The high percentages of harmonic currents in the magnetizing inrush current wave afford an excellent means of distinguishing it electrically from the fault current wave. In the Type BFC relays, the harmonic components are separated from the fundamental component by suitable electric filters previously described.

The harmonic current components are passed through the restraining coil of the relay, while the fundamental component is passed through the operating coil. The direct current component present in both the magnetizing inrush and offset fault current waves is largely blocked by the tap transformer inside the relay and produces only a slight momentary restraining effect. Relay operation occurs on current waves in which the ratio of harmonics to fundamental is lower than a given predetermined value for which the relay is set (e.g. fault current wave) and is restrained on current waves in which the ratio exceeds this value (e.g. magnetizing inrush current wave).

Burden

TABLE I

I	TAP	R	WATTS
0.5	0.5	.4	0.1
5	0.5	.4	10.0
4	4.0	.1	1.6
5	4.0	.1	2.5

*Indicates revision

GEI-98350 Harmonic Restraint Overcurrent Relay Type BFC11A

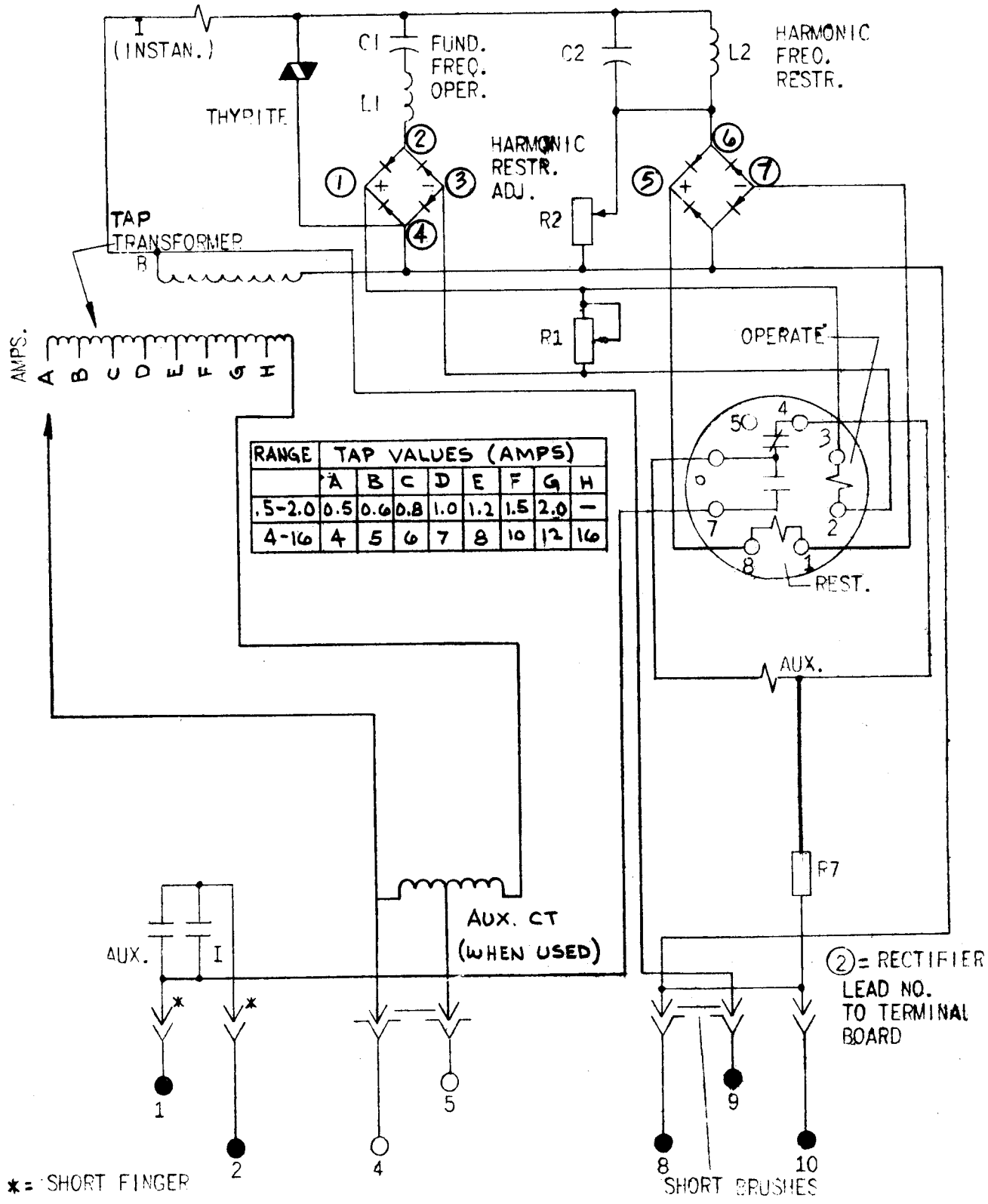

* Fig. 4 (0178A9052-3) Internal Connection Diagram for Relay Type BFC11A.

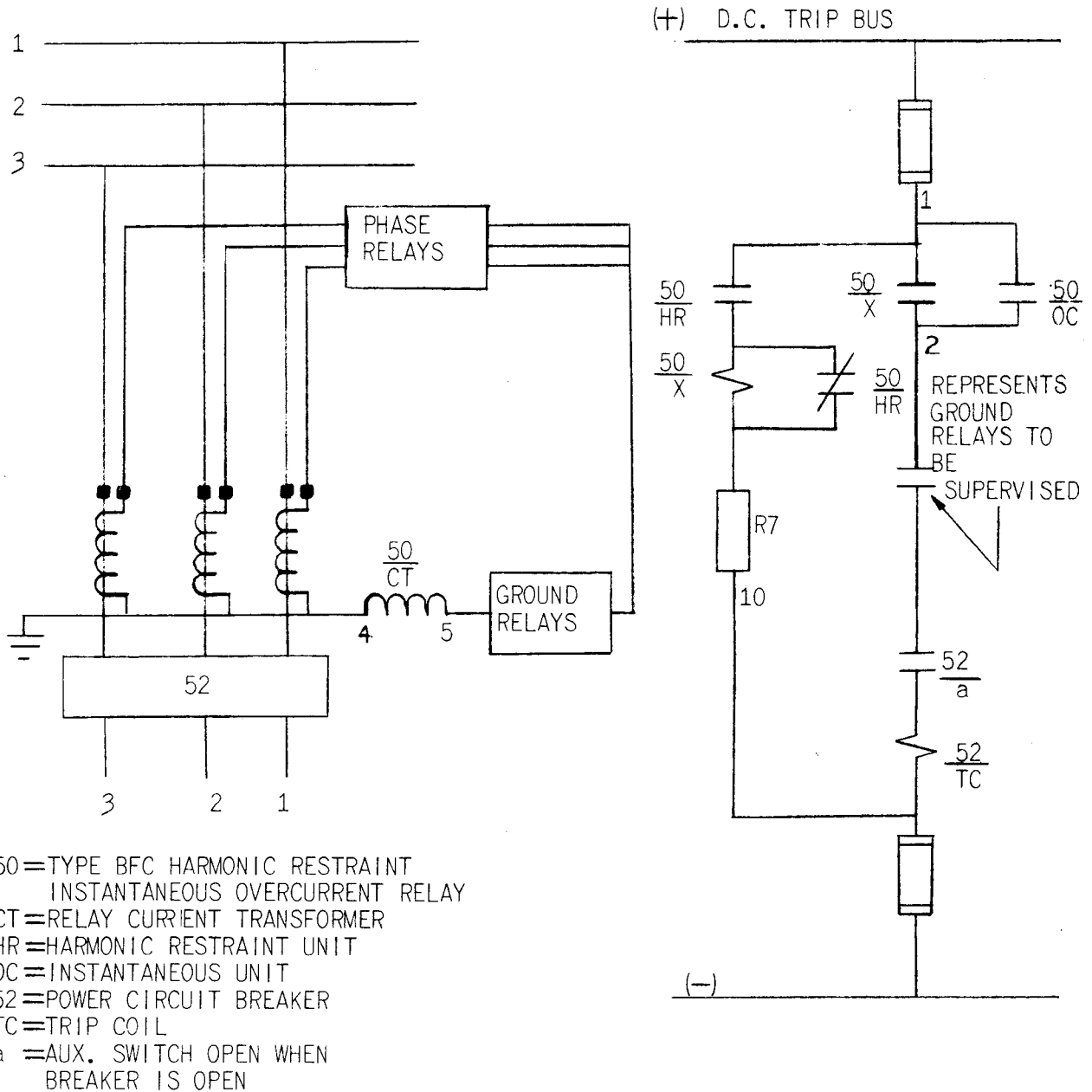

* Fig. 5 (0178A9087-3) Elementary Diagram for BFC Relay Used As Ground Fault Detector To Supervise Ground Relays.

RECEIVING, HANDLING AND STORAGE

These relays, when not included as a part of a control panel will be shipped in cartons designed to protect them against damage. Immediately upon receipt of a relay, examine it for any damage sustained in transit. If injury or damage resulting from rough handling is evident, file a damage claim at once with the transportation company and promptly notify the nearest General Electric Apparatus Sales Office.

Reasonable care should be exercised in unpacking the relay in order that none of the parts are injured or the adjustments disturbed.

If the relays are not to be installed immediately, they should be stored in their original cartons in a place that is free from moisture, dust and metallic chips. Foreign matter collected on the outside of the case may find its way inside when the cover is removed and cause trouble in the operation of the relay.

ACCEPTANCE TESTS

Immediately upon receipt of the relay an inspection and acceptance test should be made to insure that the relay has not been damaged in shipment and that the relay calibrations are unchanged.

Visual Inspection

Check the nameplate stamping to insure that the model number, rating and calibration range of the relay received agree with the requisition.

Remove the relay from its case and check by visual inspection that there are no broken or cracked molded parts or other signs of physical damage and that all screws are tight.

Mechanical Inspection

Check the operation of the auxiliary unit and instantaneous overcurrent unit manually to see that they operate smoothly without noticeable friction or binds. Check the contact gap and wipe of these units which should agree with values given under section on SERVICING.

Electrical Tests

It is recommended that the following electrical tests be made immediately upon receipt of the relay.

1. Minimum pick-up of main operating unit.
2. Minimum pick-up of the instantaneous overcurrent unit.
3. A single check point on the harmonic restraint characteristic.

Test Facilities

In order to facilitate tests, the following test equipment is recommended:

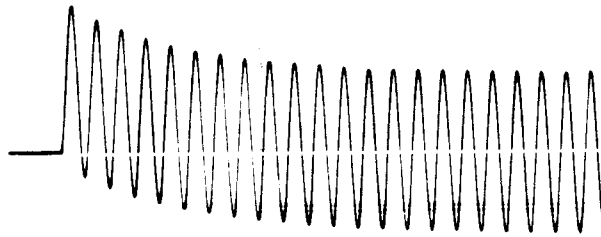

TYPICAL OFFSET FAULT CURRENT WAVE

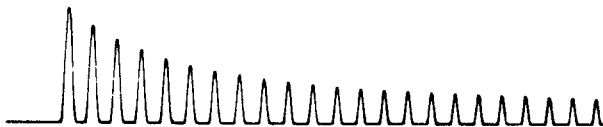

TYPICAL TRANSFORMER
MAGNETIZING INRUSH CURRENT WAVE

Fig. 6 (6209195-0) Fault Current And Magnetizing Inrush Current Waves.

studs are made through spring backed contact fingers mounted in stationary molded inner and outer blocks between which nests a removable connecting plug which completes the circuit. The outer block, attached to the case, holds the studs for the external connection, and the inner block has terminals for the internal connections.

The relay mechanism is mounted in a steel framework called the cradle and is a complete unit with all leads terminating at the inner block. This cradle is held firmly in the case with a latch at the top and bottom and by a guide pin at the back of the case. The case and cradle are so constructed that the relay cannot be inserted in the case upside down. The connecting plug, besides making the electrical connection between the blocks of the cradle and case, also locks the latch in place. The cover, which is fastened to the case by thumb-screws, holds the connecting plug in place.

To draw out the relay unit, the cover is removed and the plug is drawn out. Shorting bars are provided in the case to short the current transformer circuits (see Fig. 4). The latches are then released and the relay unit can be easily drawn out.

A separate testing plug can be inserted in place of the connecting plug to test the relay in place on the panel either from its own source of current, or from other sources. Or, the relay unit can be drawn out and replaced by another which has been tested in the laboratory.

1. Two load boxes for regulating the test currents.
2. Two ammeters (1 A.C. and 1 D.C.) for measuring the test currents.
3. A test rectifier for checking the relays response to the second harmonic.
4. One indicating lamp.
5. A double pole single throw line switch.

Pickup of the Main Operating Unit & Instantaneous Unit

Connect the relay as shown in Figure 7. Set the relay tap screw in the desired tap. Gradually apply current until the auxiliary unit operates. This value should be tap value $\pm 10\%$.

With the same connections as shown above the instantaneous unit should pick up at 24-28 times the tap setting.

Harmonic Restraint Check Point

* Connect the relay as shown in Figure 8. Set the relay in the minimum tap. Set the d-c current (I_2) as given below. Increase the a-c current (I_1) until the auxiliary relay just closes its contacts. The current should be as given below:

Tap Range	Use Tap	Set I_2 (DC Current)	I_1 Current To Operate Aux. Relay
0.5-2	0.5	4.0 amps	4.5 to 5.5
4-16	4	8.0 amps	9.0 to 11.0

INSTALLATION PROCEDURE

Visual Inspection

See "Acceptance Tests" Section

Mechanical Inspection

In addition to the mechanical inspection Section in "Acceptance Tests", the formation of the brushes in the case should be checked per Figure 9.

Every circuit in the drawout case has an auxiliary brush as shown in Fig. 9. This is the

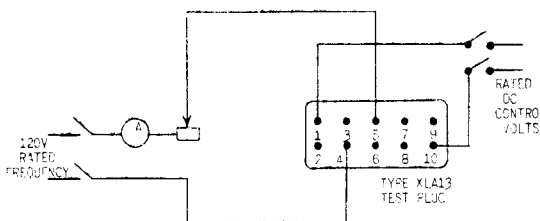

Fig. 7 (0178A9064-0) Test Connections For Checking Pickup Of Main And Instantaneous Units.

shorter brush in the case which the connecting plug should engage first. On every current circuit or other circuit with shorting bars, make sure the auxiliary brushes are bent high enough to engage the connecting plug or test plug before the main brushes; otherwise, the CT secondary circuit may be opened where one brush touches the shorting bar before the circuit is completed from the plug to the other main brush.

LOCATION & MOUNTING

The location should be clean and dry, free from dust and excessive vibration, and well lighted to facilitate inspection and testing.

The relay should be mounted on a vertical surface. The outline and panel drilling dimensions are shown in Fig. 12.

CONNECTIONS

The internal connection diagram is shown in Fig. 4. A typical wiring diagram is given in Fig. 5.

When the relay is mounted on an insulated panel, one of the steel supporting studs should be permanently grounded by a conductor not less than No. 12 B&S gage copper wire or its equivalent.

ELECTRICAL TEST

1. Pickup of the Main Unit

Connect the relay per Figure 7 & repeat test as shown in Section on "Acceptance Tests". Fine adjustment of pickup can be made by adjustment of R1.

2. Pickup of Instantaneous Unit

Connect the relay per Figure 7 & repeat test as shown in Section on "Acceptance Tests". Fine adjustment of the instantaneous unit pickup can be made by moving the adjustable core.

3. Harmonic Restraint

Connect the relay per Figure 8 & repeat the test as shown in Section on "Acceptance Test". Fine adjustment of harmonic restraint can be made by adjusting R2.

The harmonic restraint test is accomplished by means of a Test Rectifier (see Figure 10) used in conjunction with suitable ammeters and load boxes. The test circuit is as shown in Fig. 8.

The analysis of a single phase half wave rectified current shows the presence of fixed percentages of d-c, fundamental, and second harmonic components as well as negligible percentages of all higher even harmonics. This closely approximates a typical transformer inrush current as seen as the relay terminals inasmuch as its principal components are d-c, fundamental, and second harmonic. Although the percent second harmonic is fixed, the overall percentage may be varied by providing a

*Indicates revision

GEI-98350 Harmonic Restraint Overcurrent Relay Type BFC11A

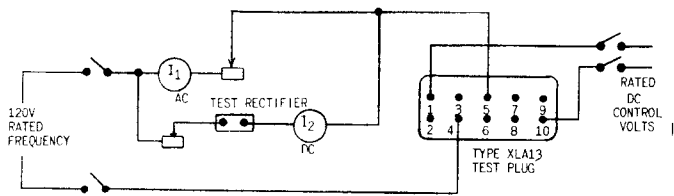
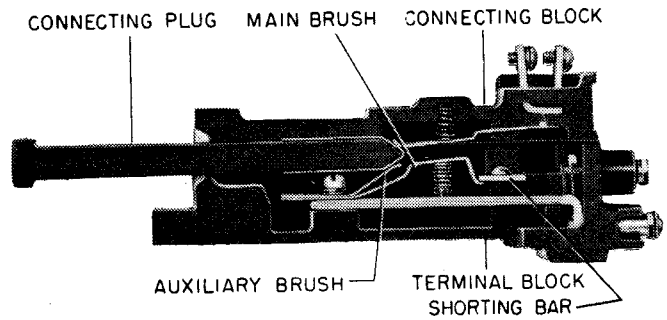

Fig. 8 (0178A9065-0) Test Connection Diagram For Checking Harmonic Restraint.



NOTE: AFTER ENGAGING AUXILIARY BRUSH, CONNECTING PLUG TRAVELS 1/4 INCH BEFORE ENGAGING THE MAIN BRUSH ON THE TERMINAL BLOCK

Fig. 9 (8025039) Cross Section Of Drawout Case Showing Position Of Auxiliary Brush And Shorting Bar.

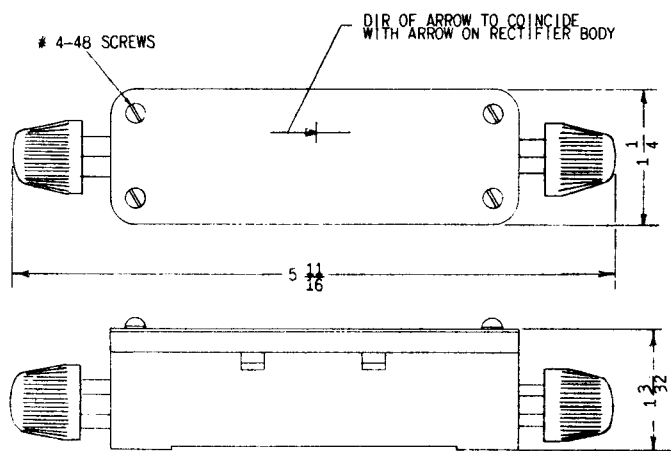

Fig. 10 (0148A2994-1) Outline Of Test Rectifier.

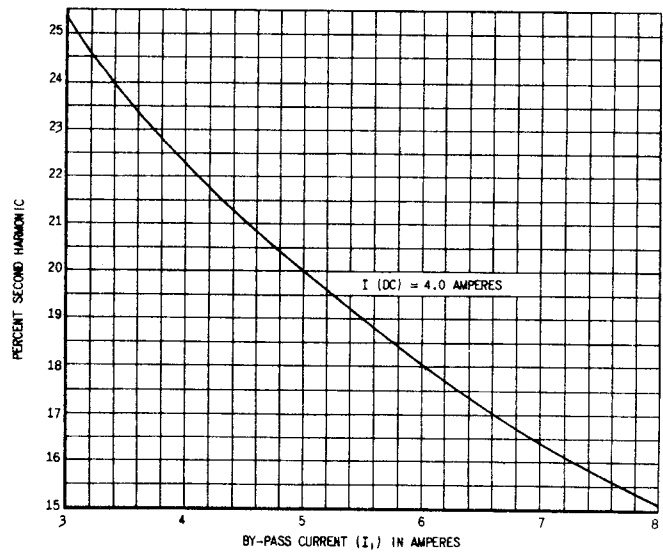

Fig. 11 (418A786-0) Curve Showing Relationship Between Percent Second Harmonic And Bypass Current

path for a controlled amount of by-passed current of fundamental frequency. The by-passed current is added in phase with the fundamental component of the half wave rectified current and thus provides a means of varying the ratio of second harmonic current to fundamental current.

The following expression shows the relationship between the percent second harmonic, the d-c component, and the by-pass current:

$$* \% \text{ Second Harmonic} = \frac{0.212 \times I_{DC}}{0.45 \times I_{AC} + 0.5 \times I_{DC}} \times 100$$

Fig. 11 is derived from the above expression and shows the percent second harmonic corresponding to various values of by pass current (I_1) for a constant d-c set at 4.0 amperes.

Periodic Tests & Routine Maintenance

An operation test & inspection of the relay & its connections should be made at least once every six months. Tests as outlined in the "INSTALLATION PROCEDURE" should be performed.

Contact Cleaning

For cleaning fine silver contacts, a flexible burnishing tool should be used. This consists of a flexible strip of metal with an etched roughened

surface, resembling in effect a superfine file. The polishing action is so delicate that no scratches are left, yet corroded material will be removed rapidly and thoroughly. The flexibility of the tool insures the cleaning of the actual points of contact.

Fine silver contacts should not be cleaned with knives, files or abrasive paper or cloth. Knives or files may leave scratches which increase arcing and deterioration of the contacts. Abrasive paper or cloth may leave minute particles of insulating abrasive material in the contacts and thus prevent closing.

The burnishing tool described is included in the standard relay tool kit obtainable from the factory.

RENEWAL PARTS

It is recommended that sufficient quantities of renewal parts be carried in stock to enable the prompt replacement of any that are worn, broken or damaged.

When ordering renewal parts, address the nearest Sales Office of the General Electric Company, specify quantity required, name of part wanted, and give complete nameplate data. If possible, give the General Electric Company requisition number on which the relay was furnished.

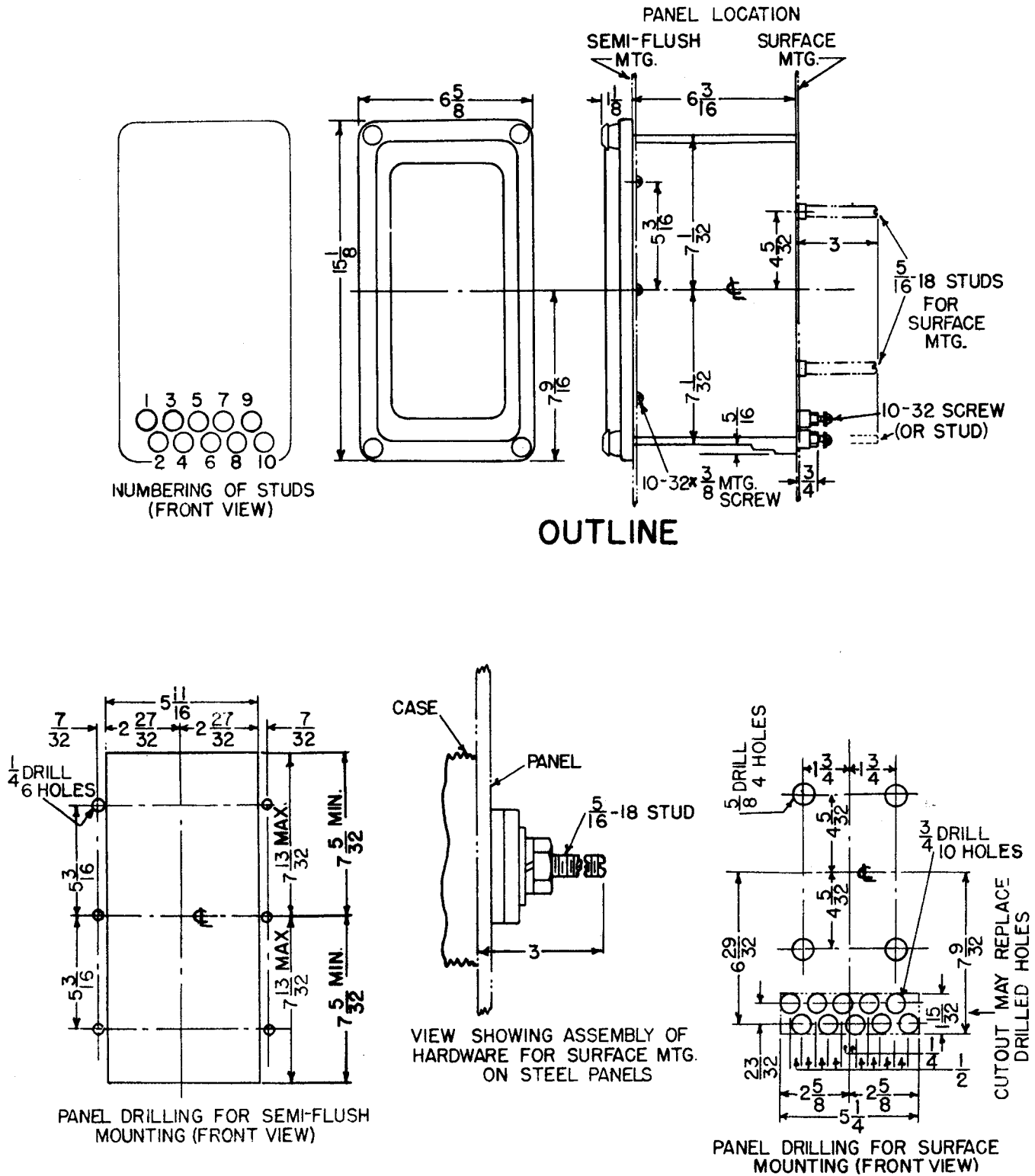

Fig. 12 (6209273-3) Outline And Panel Drilling Dimensions For Type BFC11A Relay.