



INSTRUCTIONS

OFFSET MHO DISTANCE RELAY

TYPE CEB52A

GENERAL ELECTRIC

CONTENTS

PAGE

| | |
|---|----|
| INTRODUCTION | 3 |
| APPLICATION | 3 |
| CALCULATION OF SETTINGS | 3 |
| RATINGS | 4 |
| CONTACTS | 5 |
| TARGET SEAL-IN UNIT | 5 |
| OPERATING PRINCIPLES | 6 |
| OM UNIT - ZERO OFFSET | 6 |
| CHARACTERISTICS | 6 |
| OM UNIT - WITH OFFSET | 6 |
| OM UNIT - ZERO OFFSET | 6 |
| IMPEDANCE CHARACTERISTIC | 6 |
| DIRECTIONAL ACTION | 7 |
| UNDERREACH | 7 |
| MEMORY ACTION | 7 |
| TRANSIENT OVERREACH | 8 |
| OPERATING TIME | 8 |
| TAPPED AUTOTRANSFORMER | 8 |
| BURDENS | 9 |
| CURRENT CIRCUITS | 9 |
| POTENTIAL CIRCUITS | 9 |
| CONSTRUCTION | 10 |
| RECEIVING, HANDLING AND STORAGE | 10 |
| ACCEPTANCE TESTS | 11 |
| VISUAL INSPECTION | 11 |
| MECHANICAL INSPECTION | 11 |
| ELECTRICAL CHECKS - OM UNITS | 11 |
| ELECTRICAL TESTS - TARGET SEAL-IN UNIT | 14 |
| INSTALLATION PROCEDURE | 14 |
| LOCATION | 14 |
| MOUNTING | 14 |
| CONNECTIONS | 14 |
| VISUAL INSPECTION | 14 |
| MECHANICAL INSPECTION | 14 |
| PORTABLE TEST EQUIPMENT | 14 |
| OFFSET CHECK | 14 |
| ELECTRICAL TESTS ON THE OM UNITS | 15 |
| INSPECTION | 16 |
| MHO UNITS | 17 |
| PERIODIC CHECKS AND ROUTINE MAINTENANCE | 17 |
| CONTACT CLEANING | 17 |
| SERVICING | 17 |
| CONTROL SPRING ADJUSTMENTS | 18 |
| OHMIC REACH ADJUSTMENT | 18 |
| ANGLE OF MAXIMUM TORQUE | 18 |
| RENEWAL PARTS | 18 |

NOTE: This instruction book has had a major revision. Please check your previous revision to compare material.

OFFSET MHO DISTANCE RELAY

TYPE CEB52A

INTRODUCTION

The CEB52A relay is a three-phase, high speed, single zone directional mho distance phase relay with provisions for offsetting the characteristic a fixed amount. It is constructed of three-single-phase units in one L2-D case with facilities for single-phase testing. One target and seal-in unit provides indication of operation on all three units. The transient over-reach characteristics of the CEB52A relay have not been limited to the point where it is suitable for use as a first zone relay. This relay was designed primarily for use as a carrier starting relay in directional comparison schemes. It is also applicable as a second or third zone relay in straight distance schemes.

APPLICATION

The CEB52A was specifically designed for application as a carrier starting relay in directional comparison relaying schemes. To serve this purpose the relay is equipped with normally closed contacts as well as with normally open contacts. Since many originally straight distance terminals are later converted to directional comparison terminals, the CEB52A should be used as the third zone relay in straight distance schemes to facilitate any future conversion.

The offset feature should always be used when the relay is employed to start the carrier or when it is required to operate in conjunction with some time delay for zero voltage faults.

In carrier starting applications the normally closed contacts are closed under normal conditions to hold off carrier. When line side potentials are employed, and the line is deenergized, the relay will have no electrical restraint and will depend on the control spring to provide sufficient contact pressure to keep carrier turned off. It is for this reason that this relay has a relatively strong spring setting. Figs. 5 and 6 give the operating characteristics for this relay with the strong spring setting, with and without offset.

When the relay is employed with bus potentials, or if it is used in straight distance schemes, a weaker spring setting may be employed. The section under SERVICING describes how the spring setting can be changed. Figs. 7 and 8 give the operating characteristics for the weaker spring setting with and without offset. The CEB52A will be calibrated in the factory with the strong setting.

The CEB52A relay and its comparison zone packaged relays may be combined in several different ways for use in straight distance and directional comparison relaying schemes. Fig. 17 illustrates how the CEY51A, CEY52A, and CEB52A relays plus the RPM21D timing relay may be employed for three zone directional distance protection of transmission circuits against all multi-phase faults. Separate ground fault relays are required for single-phase-to-ground faults. Fig. 18 shows how these same distance relays plus a SAM16A static timing relay and the necessary ground and auxiliary relays are combined in a directional comparison relaying scheme.

The section under CALCULATION OF SETTINGS provides a typical worked example covering the setting of this relay.

CALCULATION OF SETTINGS

Consider one terminal of a two terminal 69KV transmission line, 17.3 miles long having a phase-to-neutral impedance of

$$Z_{\text{prim}} = 0.14 + j 0.80 \text{ ohms per mile}$$

$$Z = 17.3 (0.14 + j 0.80) = 2.4 + j 13.9 \text{ ohms total}$$

These instructions do not purport to cover all details or variations in equipment nor to provide for every possible contingency to be met in connection with installation, operation or maintenance. Should further information be desired or should particular problems arise which are not covered sufficiently for the purchaser's purposes, the matter should be referred to the General Electric Company.

To the extent required the products described herein meet applicable ANSI, IEEE and NEMA standards; but no such assurance is given with respect to local codes and ordinances because they vary greatly.

The terms $(a + jb)$ and $(c + jd)$ represent the burden of the mho unit potential circuits expressed in watts and vars with their taps on 100 percent. The values of these terms are given in Table VI.

TABLE VI

| Rated Frequency | "a" Watts | "b" Vars | "c" Watts | "d" Vars |
|-----------------|-----------|----------|-----------|----------|
| 60 | 4.6 | +j6.5 | 9.1 | -j1.0 |
| 50 | 4.7 | +j6.6 | 7.9 | -j0.8 |

CONSTRUCTION

The type CEB52A relays are assembled in a deep large-size, double-end (L2D) drawout case having studs at both ends in the rear for external connections. The electrical connections between the relay units and the case studs are made through stationary molded inner and outer blocks between which nests a removable connecting plug which completes the circuits. The outer blocks attached to the case have the studs for the external connections, and the inner blocks have the terminals for the internal connections.

Every circuit in the drawout case has an auxiliary brush, as shown in Fig. 11, to provide adequate overlap when the connecting plug is withdrawn or inserted. Some circuits are equipped with shorting bars (see internal connections in Fig. 12), and on those circuits, it is especially important that the auxiliary brush make contact as indicated in Fig. 11 with adequate pressure to prevent the opening of important interlocking circuits.

The relay mechanism is mounted in a steel framework called the cradle and is a complete unit with all leads terminated at the inner blocks. This cradle is held firmly in the case with a latch at both top and bottom and by a guide pin at the back of the case. The connecting plug, besides making the electrical connections between the respective blocks of the cradle and case, also locks the latch in place. The cover, which is drawn to the case by thumbscrews, holds the connecting plugs in place. The target reset mechanism is a part of the cover assembly.

The relay case is suitable for either semiflush mounting on all panels up to two inches thick and appropriate hardware is available. However, panel thickness must be indicated on the relay order to insure that proper hardware will be included.

A separate testing plug can be inserted in place on the panel either from its own source of current and voltage, or from other sources, or the relay can be drawn out and replaced by another which has been tested in the laboratory.

Fig. 1 shows the relay removed from its drawout case with all major components identified. Symbols used to identify circuit components are the same as those which appear on the internal connection diagram in Fig. 12.

The relay includes three similar mho sub-assembly elements mounted on the front of the cradle and a plate with transformers and tap blocks mounted on the back of the cradle (see Fig. 1).

The mho sub-assembly includes the four pole unit and the associated circuit components. Rheostats (R21, R22, R23) used in setting the angle of maximum torque and rheostats R11, R12, R13, used in setting the basic minimum reach can be adjusted from the front of the relay.

The tap blocks for changing the basic minimum reach of the units and for selecting the offset are mounted on the back. The relay must be removed from its case to make the settings.

RECEIVING, HANDLING AND STORAGE

These relays, when not included as a part of a control panel, will be shipped in cartons designed to protect them against damage. Immediately upon receipt of a relay, examine it for any damage sustained in transit. If injury or damage resulting from rough handling is evident, file a damage claim at once with the transportation company and promptly notify the nearest General Electric Company Apparatus Sales Office.

Reasonable care should be exercised in unpacking the relay in order that none of the parts are injured or the adjustments disturbed.

If the relays are not to be installed immediately, they should be stored in their original cartons in a place that is free from moisture, dust and metallic chips. Foreign matter collected on the outside of the case may find its way inside when the cover is removed and cause trouble in the operation of the relay.

ACCEPTANCE TESTS

Immediately upon receipt of the relay, an INSPECTION AND ACCEPTANCE TEST should be made to insure that no damage has been sustained in shipment and that the relay calibrations have not been disturbed. If the examination or test indicates that readjustment is necessary, refer to the section on SERVICING.

VISUAL INSPECTION

Check the nameplate stamping to insure that the model number and rating of the relay agree with the requisition.

Remove the relay from its case and check that there are no broken or cracked molded parts or other signs of physical damage, and that all screws are tight.

MECHANICAL INSPECTION

1. It is recommended that the mechanical adjustments in Table VII be checked.
2. There should be no noticeable friction in the rotating structure of the units.
3. Make sure control springs are not deformed and spring convolutions do not touch each other.
4. With the relay well leveled in its upright position, the contacts of all three units must be open. The moving contacts of the units should rest against the backstop.
5. The armature and contacts of the seal-in unit should move freely when operated by hand. There should be at least 1/32 inch wiper on the seal-in contacts.
6. Check the location of the contact brushes on the cradle and case blocks against the internal connection diagram for the relay.

TABLE VII

| CHECK POINTS | OM UNITS |
|-------------------------|--------------------|
| Rotating Shaft End Play | 0.010 - 0.015 Inch |
| Contact Gap | 0.040 - 0.060 Inch |
| Contact Wipe | 0.003 - 0.005 Inch |

ELECTRICAL CHECKS - OM UNITS

Before any electrical checks are made on the mho units the relay should be connected as shown in Fig. 13 and be allowed to warm up for approximately 15 minutes with the potential circuit alone energized at rated voltage and the restraint taps set at 100 percent. The units were warmed up prior to factory adjustment and if rechecked when cold will tend to underreach by three or four percent. Accurately calibrated meters are of course essential.

It is desirable to check the factory setting and calibrations by means of the tests described in the following sections. The OM units were carefully adjusted at the factory and it is not advisable to disturb these settings unless the following checks indicate conclusively that the settings have been disturbed. If readjustments are necessary refer to the section on SERVICING for the recommended procedures.

Test connections for checking correct OM unit operation are shown in Fig. 13.

1. CONTROL SPRING ADJUSTMENT

Be sure that the relay is level in its upright position. Leave the relay connected as shown in Fig. 13 and leave the restraint taps in the 100 percent position.

Use the following procedure in checking each unit. With the current set at five amperes and the voltage studs at 120 volts, set the phase shifter so that the phase angle meter reads the value shown in Table VIIIa for the unit being tested, that is so current lags voltage by an angle equal to the angle of maximum torque of the unit. Now reduce the voltage to the low test voltage, and reduce the current to about one ampere. Gradually increase the current until the contacts of the unit just close. This should occur between the current listed in Table VIII.

TABLE VIII-a

| Basic Minimum Reach Tap | Tap Used | Phase Angle Meter Reads | Set V_{AB} (Volts) | Pickup Current (Amps) | Offset |
|-------------------------|----------|-------------------------|----------------------|-----------------------|--------|
| 0.5 - 1.5 | 1.0 | 285 | 4.0 | 4.25 - 5.75 | Out |
| 1.0 - 3.0 | 2.0 | 285 | 4.0 | 2.12 - 2.88 | Out |
| 2.0 - 6.0 | 4.0 | 285 | 4.0 | 1.06 - 1.44 | Out |

2. CLUTCH ADJUSTMENT

The OM units include a high-set clutch between the cup and shaft assembly and the moving contact to prevent damage during heavy fault conditions. These clutches have been set at the factory to slip at approximately 40-60 grams applied tangentially at the moving contact. This can best be checked in the field in terms of volt-amperes by the following method.

Use the connections of Fig. 13 and set the phase shifter so that the phase angle meter reads the value in Table IX for the unit to be checked, at 120 volts and five amperes. Disconnect the No. 1 restraint tap leads from the tap block and set the mho units for maximum basic minimum reach and offset "out". With the voltage across relay studs set at 120V, increase the current until the clutch just slips. This should occur between the values given below:

TABLE VIII-b

| Basic Ohmic Range | Use Tap | Current to just Slip Clutch (Amps) |
|-------------------|---------|------------------------------------|
| 0.5 - 1.5 | 1.5 | over - 60 amps |
| 1 - 3 | 3.0 | 34 - 56 |
| 2 - 6 | 6.0 | 16.0 - 28 |

3. OHMIC REACH

With the relay still connected as shown in Fig. 13 and the restraint tap leads in the 100 percent position, make connections shown in Table IX and set the phase shifter so that the phase angle meter reads the angle shown in the table for the unit to be checked.

Now reduce the voltage to the value shown in Table IX and increase the current gradually until the normally open contacts of the unit just close. This should occur within the limits shown in Table IX. Note that the links on the tap blocks are set to the position which gives the basic minimum reach shown in the table.

Note that for the test conditions, the OM units sees a phase-to-phase fault of twice the basic minimum reach.

The relays are normally shipped from the factory with the basic minimum reach adjustment taps of the units in the middle setting. If the units are set on either of the remaining basic minimum reach taps, the basic reach of the units will be within ± 5 percent of the tap plate marking.

NOTE: Basic minimum reach is equal to (A + B) link settings.

TABLE IX

| Basic Minimum Reach Tap | Tap Used | Phase Angle Meter Reads | Set V_{AB} (Volts) | Pickup Current (Amps) | Offset |
|-------------------------|----------|-------------------------|----------------------|-----------------------|--------|
| 0.5 - 1.5 | 1.0 | 285 | 40 | 19.2 - 20.8 | Out |
| 1.0 - 3.0 | 2.0 | 285 | 60 | 14.4 - 15.6 | Out |
| 2.0 - 6.0 | 4.0 | 285 | 60 | 7.2 - 7.8 | Out |

4. ANGLE OF MAXIMUM TORQUE

For checking the angle of maximum torque the connections of Fig. 13 will be used with the restraint tap leads set at 100 percent position, and with the voltage set at the value shown in Table X for the unit to be checked. The minimum reach taps should be set on the middle reach position.

In checking the mho units the following procedure would be used. First set the phase shifter so that the phase angle meter reads 315 degrees. Note that while the phase angle is being set, the current should be at five amperes and the voltage shown in Table X. Increase the current slowly until the mho unit picks up. The pickup current should be within the limits shown in the table. Now reset the phase angle at 255 degrees and again check the current required to pick up the mho unit. This current should fall within the same limits as for the 315 degree check.

Note that the two angles used in the previous check, i.e. 315 degrees and 255 degrees, are 30 degrees away from the angle of maximum torque. An examination of the OM unit impedance characteristic in Fig. 4 shows that the ohmic reach of the unit should be the same at both 315 degrees and 255 degrees and should be 0.866 times the reach at the angle of maximum torque.

TABLE X

| Basic Minimum Ohmic Tap | Use Tap | Phase Angle Meter Reading | | | V_{AB} Set at (Volts) | Pickup (amps) | Offset |
|-------------------------|---------|---------------------------|-------------|-----|-------------------------|---------------|--------|
| | | Maximum Torque Angle | Test Angles | | | | |
| 0.5 - 1.5 | 1.0 | 285 | 315 | 255 | 40 | 21.7 - 24.5 | Out |
| 1 - 3.0 | 2.0 | 285 | 315 | 255 | 60 | 16.5 - 18.5 | Out |
| 2 - 6 | 4.0 | 285 | 315 | 255 | 60 | 8.2 - 9.2 | Out |

5. OFFSET CHECK

With the relay connected as shown in Fig. 13 and the restraint tap leads in the 100 percent position, make settings shown on Table XI and set the phase shifter so that the phase angle meter reads the angle shown in the table for the unit to be checked.

Reduce the voltage to the value shown and increase the current gradually until the normally open contacts of the unit just close. This should occur within the current limits shown in Table XI.

TABLE XI

| Basic Minimum Ohmic Tap | Use Tap | Phase Angle Meter Reads | Offset | V_{AB} Set at (Volts) | Pickup (Amps) |
|-------------------------|---------|-------------------------|--------|-------------------------|---------------|
| 0.5 - 1.5 | 1.0 | 105 | 0.25 | 10 | 18 - 22 |
| 1.0 - 3.0 | 2.0 | 105 | 0.20 | 8 | 18 - 22 |
| 1.0 - 3.0 | 2.0 | 105 | 0.50 | 20 | 18 - 22 |
| 2.0 - 6.0 | 4.0 | 105 | 0.50 | 20 | 18 - 22 |

ELECTRICAL TESTS - TARGET SEAL-IN UNIT

The target seal-in unit has operating coils as given in Table II.

The relay is shipped from the factory with the tap screw in the maximum ampere position. The operating point of the seal-in unit can be checked by connecting from DC source (+) to stud 11 of the relay and from stud 1 through an adjustable resistor and ammeter back to (-). Connect a jumper from stud 12 to stud 1 also so that the seal-in contact will protect the OM unit contacts. Then close the OM unit contact by hand and increase the DC current until the seal-in unit operates. It should pick up at tap value or slightly lower. Do not attempt to interrupt the DC current by means of the OM contacts.

INSTALLATION PROCEDURELOCATION

The location of the relay should be clean and dry, free from dust excessive heat and vibration, and should be well lighted to facilitate inspection and testing.

MOUNTING

The relay should be mounted on a vertical surface. The outline and panel drilling dimensions are shown in Fig. 20.

CONNECTIONS

The internal connections of the CE852A relay are shown in Fig. 12. An elementary diagram of typical external connections is shown in Figs. 17 and 18.

VISUAL INSPECTION

Remove the relay from its case and check that there are no broken or cracked component parts and that all screws are tight.

MECHANICAL INSPECTION

Recheck the six adjustments mentioned under MECHANICAL INSPECTION in the section under ACCEPTANCE TESTS.

PORTABLE TEST EQUIPMENT

To eliminate the errors which may result from instrument inaccuracies and to permit testing the mho units from a single-phase AC test source, the test circuit shown in schematic form in Fig. 14 is recommended. In this first $R_S + jK_S$ is the source impedance, SF is the fault switch, and $R_L + jX_L$ is the impedance of the line section for which the relay is being tested. The autotransformer TA, which is across the fault switch and line impedance is tapped in 10 percent and one percent steps so that the line impedance $R_L + jX_L$ may be made to appear to the relay very nearly as the actual line on which the relay is to be used. This is necessary since it is not feasible to provide the portable test reactor X_L and the test resistor with enough taps so that the combination may be made to match any line.

OFFSET CHECK

With the relay connected as shown in Fig. 13 and the restraint tap leads in the 100 percent position, make settings shown on Table XI and set the phase shifter so that the phase angle meter reads the angle shown in the table for the unit to be checked.

Reduce the voltage to the value shown and increase the current gradually until the normally open contacts of the unit just close. This should occur within the current limits shown in Table XI.

For convenience in field testing, the fault switch and tapped autotransformer of Fig. 14 have been arranged in a portable test box, Cat. No. 102-L201, which is particularly adapted for testing directional and distance relays. The box is provided with terminals to which the relay current and potential circuits as well as the line and source impedances may be readily connected. For a complete description of the test box the user is referred to GEI-38977.

ELECTRICAL TESTS ON THE OM UNITS

The manner in which reach settings are made for the OM units is briefly discussed in the CALCULATION OF SETTINGS section. Examples of calculations for typical settings are given in that section. It is the purpose of the electrical tests in this section to check the ohmic pickup of the OM units at the settings which have been made for a particular line section.

To check the calibration of the OM units, it is suggested that the portable test box, Cat. No. 102-L201; portable test reactor, Cat No. 6054975; and test resistor, Cat. No. 6158546 be arranged with Type XLA test plugs according to Fig. 15. These connections of the test box and other equipment are similar to the schematic connections shown in Fig. 14 except that the Type XLA test plug connections are now included.

Use of the source impedance $R_S + kX_S$, simulating the conditions which would be encountered in practice, is necessary only if the relay is to be tested for overreach or contact coordination, tests which are not normally considered necessary at the time of installation or during periodic testing. Some impedance will usually be necessary in the source connection to limit current in the fault circuit to a reasonable value, especially when a unit with short reach setting is to be checked, and it is suggested that a reactor of suitable value be used for this purpose since this will tend to limit harmonics in the fault current.

Since the reactance of the test reactor may be very accurately determined from its calibration curve, it is desirable to check mho unit pickup with the fault reactor alone, due account being taken of the angular difference between the line reactance, X_L , and mho unit angle of maximum reach. The line reactance X_L , selected should be the test reactor tap nearest above twice the mho unit phase-to-neutral reach with account being taken of the difference in angle of the test reactor tap impedance and the unit angle of maximum reach. From Fig. 16 it is seen that twice the relay reach of the angle of the test reactor impedance is:

$$2Z \text{ Relay} = 200 \frac{Z \text{ Min.}}{\text{Tap Setting \%}} \cos (\phi - \theta)$$

where:

ϕ = the angle of the test reactor impedance

θ = mho unit angle of maximum reach

Z Min = Basic minimum reach of mho units

To illustrate by an example let us consider the percent tap required on the test box autotransformer for a unit that has been factory adjusted to pick up at three ohms minimum and at a maximum torque angle of 75 degrees. In determining the reactor tap setting to use, it may be assumed that the angle (ϕ) of the test reactor impedance is 80 degrees. From the above twice the relay reach at the angle of the test-reactor impedance is

$$2Z \text{ Relay} = 200 \times \frac{3}{100} \cos (80-75) = 5.98$$

Therefore, use the reactor six-ohm tap. Twice the relay reach at the angle of test reactor impedance should be recalculated using the actual angle of the reactor tap impedance rather than the assumed 80 degrees. Table XII shows the angles for each of the reactor taps.

TABLE XII

| TAP | ANGLE | COS $\phi-60$ |
|-----|-------|---------------|
| 24 | 88 | 0.883 |
| 12 | 87 | 0.891 |
| 6 | 86 | 0.899 |
| 3 | 85 | 0.906 |
| 2 | 83 | 0.921 |
| 1 | 81 | 0.934 |
| 0.5 | 78 | 0.951 |

From Table XII it is seen that the angle of the impedance of the six-ohm tap is 86 degrees. Therefore:

$$2 Z \text{ relay} = 200 \times \frac{3}{100} \cos (86-75) = 5.89 \text{ ohms}$$

The calibration curve for the portable test reactor should again be referred to in order to determine the exact reactance of the six-ohm tap at the current level being used. For the purpose of this illustration assume that the reactance is 6.1 ohms. Since the angle of the impedance of the six-ohm tap is 86 degrees, the impedance of this tap may be calculated as follows:

$$X_L = \frac{X_L}{\sin 86} = \frac{6.1}{0.9976} = 6.115$$

From this calculation it is seen that the reactance and the impedance may be assumed the same for this particular reactor tap. Actually the difference need only be taken into account on the reactor's 3, 2, 1 and 0.5-ohm taps.

The test box autotransformer tap setting required to close the mho-unit contacts with the fault switch closed is:

$$\% = \frac{5.89}{6.1} (100) = 96.6\% \text{ (use 97\% tap)}$$

Fig. 6 should be checked to determine that the test current used is high enough so that the characteristic is not off the calculated value because of low current.

If the ohmic pickup of the mho unit checks correctly according to the above, the chances are that the angle of the characteristic is correct. The angle may, however, be very easily checked by using the calibrated test resistor in combination with various reactor taps. The calibrated test resistor taps are pre-set in such a manner that when used with twelve and six-ohm taps of the specified test reactor, impedances at 60 degrees and 30 degrees respectively will be available for checking the mho unit reach at the 60 degree and 30 degree position. The mho-unit ohmic reach at the zero-degree position may be checked by using the calibrated test resistor alone as the line impedance. The calibrated test resistor is supplied with a data sheet which gives the exact impedance and angle for each of the combinations available. The test-box autotransformer percent tap for pickup at a particular angle is given by:

$$\% \text{ Tap} = \frac{200Z_{\text{min}} \cos (\emptyset - \theta)(100)}{Z_L \text{ (Tap Setting \%)}}$$

where θ is the angle of maximum torque of the unit. \emptyset is the angle of the test impedance (Z_L), Z_L is the 60 degree, 30 degree or zero degree impedance value taken from the calibrated resistor data sheet. As in the case of the previous tests, the load box which serves as source impedance should be adjusted to allow approximately 10 amperes to flow in the fault circuit when the fault switch is closed.

When checking the mho unit at angles of more than 30 degrees off the maximum reach position, the error becomes relatively large with phase angle error. This is apparent from Fig. 16 where it is seen for example, at the zero-degree position that a two or three degree error in phase angle will cause a considerable apparent error in reach.

INSPECTION

Before placing a relay into service, the following mechanical adjustments should be checked, and faulty conditions corrected according to instructions in the ADJUSTMENTS subsection of this section or under the MAINTENANCE section.

The armature and contacts of the target and seal-in unit should operate freely by hand.

There should be a screw in only one of the taps on the right-hand contact of the target and seal-in unit.

The target should reset promptly when the reset button at the bottom of the cover is operated, with the cover on the relay.

MHO UNITS

There should be no noticeable friction in the rotating structure of the mho unit. The mho unit moving contact should just return to the backstop when the relay is de-energized, and in the vertical position.

There should be approximately 0.010-0.015 inch end play in the shafts of the rotating structures. The lower jewel screw bearing should be screwed firmly into place, and the top pivot locked in place by its set screw.

All nuts and screws should be tight, with particular attention to the tap plugs.

The felt gasket on the cover should be securely cemented in place in order to keep out dust. Determine the impedance and phase angle seen by the relays. Knowing the impedance and phase angle seen by the relay, the tap value at which the relay will just operate can be calculated. It is then only necessary to reduce the tap setting of the relay until the mho units operate and see how close the actual tap value found, checks with the calculated value. The calculated value should taken into account the shorter reach of the mho unit at low currents. This effect is shown in Fig. 6 or 7.

A shorter test which will check for most of the possible open circuits in the AC portion of the relay is to disconnect the current circuits. All units should have strong torque to the right when full voltage is applied.

Replace the lower plug and open the restraint taps. All units should operate if power and reactive flow are away from the station bus and into the protected line section. If the direction of reactive power flow is into the station bus, the resultant phase angle may be such that the units will not operate.

PERIODIC CHECKS AND ROUTINE MAINTENANCE

In view of the vital role of protective relays in the operation of a power system it is important that a periodic test program be followed. It is recognized that the interval between periodic checks will vary depending upon environment, type of relay, and the user's experience with periodic testing. Until the user has accumulated enough experience to select the test interval best suited to his individual requirements it is suggested that the points listed under INSTALLATION AND PROCEDURE be checked at an interval of from one to two years.

CONTACT CLEANING

For cleaning fine silver contacts, a flexible burnishing tool should be used. This consists of a flexible strip of metal with an etched-roughened surface resembling in effect a superfine file. The polishing action is so delicate that no scratches are left, yet it will clean off any corrosion thoroughly and rapidly. Its flexibility insures the cleaning of the actual points of contact. Do not use knives, files, abrasive paper or cloth of any kind to clean relay contacts.

SERVICING

If it is found during the installation or periodic tests that the mho unit calibrations are out of limits, they should be recalibrated as outlined in the following paragraphs. It is suggested that these calibrations be made in the laboratory. The circuit components listed below, which are normally considered as factory adjustments, are used in recalibrating the units. These parts may be physically located from Fig. 1. Their locations in the relay circuit are shown in the internal connection diagram of Fig. 12.

R_{11} - \emptyset_1 -2 unit ohmic reach adjustment.

R_{21} - \emptyset_1 -2 unit angle of maximum torque adjustment.

R_{12} - \emptyset_2 -3 unit ohmic reach adjustment.

R_{22} - \emptyset_2 -3 unit angle of maximum torque adjustment.

R_{13} - \emptyset_3 -1 unit ohmic reach adjustment.

R_{23} - \emptyset_3 -1 unit angle of maximum torque adjustment.

NOTE: Before making pickup or phase angle adjustments on the mho units, the units should be allowed to heat up for approximately 15 minutes energized with rated voltage alone and the restraint tap leads set for 100 percent. Also it is important that the relay be mounted in an upright position so that the units are level.

DIRECTIONAL ADJUSTMENTS

Set the reach taps in the middle reach position on all taps. Set the restraint tap leads on 100%. Adjust the control spring so the moving contact just floats in the center of its travel. With offset at zero (0), connect the relay per Figure 13, but remove the voltage from leads "A-B" and short the terminals on the relay corresponding to "A-B" for the unit under test.

Adjust the core of the unit under test so that the contacts remain in the neutral position or have a slight opening bias as the current is increased from 0 to 60 amperes.

Unshort the potential studs.

CONTROL SPRING ADJUSTMENTS

Make connections to the relay as shown in Fig. 13 and set the restraint tap leads on 100 percent. The basic reach taps should be set in the position for the basic minimum reach shown in Table XIII. Make sure that the relay is in an upright position so that the units are level. With the current set at five amperes and the voltage V_{A-B} at 120 volts, set phase shifter so that the phase angle meter reads the value shown in Table XIII.

Now reduce the voltage to the test voltage value and set the current at the value shown in Table XIII for the unit being adjusted. Insert a blade of a thin screwdriver into one of the slots in the edge of the spring adjusting ring and turn the ring until the contacts of the unit just close. If the contacts were closing below the set point shown in Table XIII, the adjusting ring should be turned to the right. If they were closing above the set point, the adjusting ring should be turned to the left.

OHMIC REACH ADJUSTMENT

The basic minimum reach of the OM units can be adjusted by means of the rheostats which are accessible from the front of the relay. Connect the relay as shown in Fig. 13, leave the restraint taps at 100 percent, and be sure that the basic minimum reach taps are in the position shown in Table XIV. With current at five amperes, and voltage at 120 volts set the phase shifter so that the phase angle meter reads the angle shown in the table for the unit to be checked. Now reduce the voltage V_{AB} to the set value shown in Table XIV and adjust the appropriate rheostat so that the unit picks up at 15 amperes plus or minus two percent.

ANGLE OF MAXIMUM TORQUE

The angle of maximum torque of the OM units can be adjusted by means of rheostats which are accessible from the front of the relay. Use the connections in Fig. 13. Leave the restraint taps at 100 percent and be sure that the basic minimum reach taps are in the position shown in Table XIII.

The procedure used in setting angle of maximum torque is to adjust the reactor so that the pickup amperes, at a specified set voltage V_{AB} will be the same at angles leading and lagging the maximum torque angle by 30 degrees. The test angles, set voltages, and the pickup amperes are shown in Table XV. First, the reach of the unit at its angles of maximum torque should be checked and adjusted if necessary as described in OHMIC REACH ADJUSTMENT and Table XV. Next set the phase shifter so that the phase angle meter reads 315 degrees (note that phase angle adjustments should be made at 120 volts and five amperes). Then set V_{AB} at 60 volts and adjust the proper reactor so that the ohm unit closes its contacts at 17.3 amperes plus or minus two percent. The pickup should then be checked at 255 degrees with the same set voltage and should be 17.3 amperes plus or minus two percent. Refine the adjustments or rheostats until the pickup is within limits at both 255 degrees and 315 degrees.

Note that an adjustment of the angle of maximum torque will have a secondary effect on the reach of the unit, and vice versa. Therefore, to insure accurate settings it is necessary to recheck the reach of a unit whenever its angle of maximum torque setting is changed, and to continue a "cross" adjustment routine of reach and angle of maximum torque until both are within the limits specified above.

RENEWAL PARTS

It is recommended that sufficient quantities of renewal parts be carried in stock to enable the prompt replacement of any that are worn, broken, or damaged.

When ordering renewal parts, address the nearest Sales Office of the General Electric Company, specify quantity required, name of the part wanted and give complete nameplate data. If possible, give the General Electric Requisition number on which the relay was furnished.

TABLE XIII

| Basic Minimum Reach Taps | Tap Used | Phase Angle Meter Reads | Set V_{AB} (Volts) | Set Value of Current | | Offset |
|--------------------------|----------|-------------------------|----------------------|----------------------|--------------------|--------|
| | | | | Strong Spring (Amps) | Weak Spring (Amps) | |
| 0.5 - 1.5 | 1.0 | 285° | 4.0 | 4.25-5.75 | 2.35-3.20 | Out |
| 1.0 - 3.0 | 2.0 | 285° | 4.0 | 2.12- 2.88 | 1.17-1.50 | Out |
| 2.0 - 6.0 | 4.0 | 285° | 4.0 | 1.06-1.44 | 0.60-0.80 | Out |

TABLE XIV

| Basic Minimum Reach Taps | Tap Used | Phase Angle Meter Reads | Set V_{AB} (Volts) | Pickup Current (Amps) | Adjustment | | | Offset |
|--------------------------|----------|-------------------------|----------------------|-----------------------|-----------------|-----------------|-----------------|--------|
| | | | | | Unit | | | |
| | | | | | Top | Middle | Bottom | |
| 0.5 - 1.5 | 1.0 | 285° | 30 | 14.8-15.2 | R ₁₁ | R ₁₂ | R ₁₃ | Out |
| 1.0 - 3.0 | 2.0 | 285° | 60 | 14.8-15.2 | R ₁₁ | R ₁₂ | R ₁₃ | Out |
| 2.0 - 6.0 | 4.0 | 285° | 90 | 11.1-11.4 | R ₁₁ | R ₁₂ | R ₁₃ | Out |

TABLE XV

| Basic Minimum Reach Tap | Tap Used | Phase Angle Meter Reads | | Set V_{AB} (Volts) | Pickup (Amps) | Adjustment | | | Offset |
|-------------------------|----------|-------------------------|-------------|----------------------|---------------|-----------------|-----------------|-----------------|--------|
| | | Maximum Torque Angle | Test Angles | | | Unit | | | |
| | | | | | | Top | Middle | Bottom | |
| 0.5-1.5 | 1.0 | 285° | 315 255 | 30 | 17.0-17.5 | R ₂₁ | R ₂₂ | R ₂₃ | Out |
| 1.0-3.0 | 2.0 | 285° | 315 255 | 60 | 17.0-17.5 | R ₂₁ | R ₂₂ | R ₂₃ | Out |
| 2.0-6.0 | 4.0 | 285° | 315 255 | 90 | 12.8-13.2 | R ₂₁ | R ₂₂ | R ₂₃ | Out |

Since the last edition, Figure 20 has been revised.

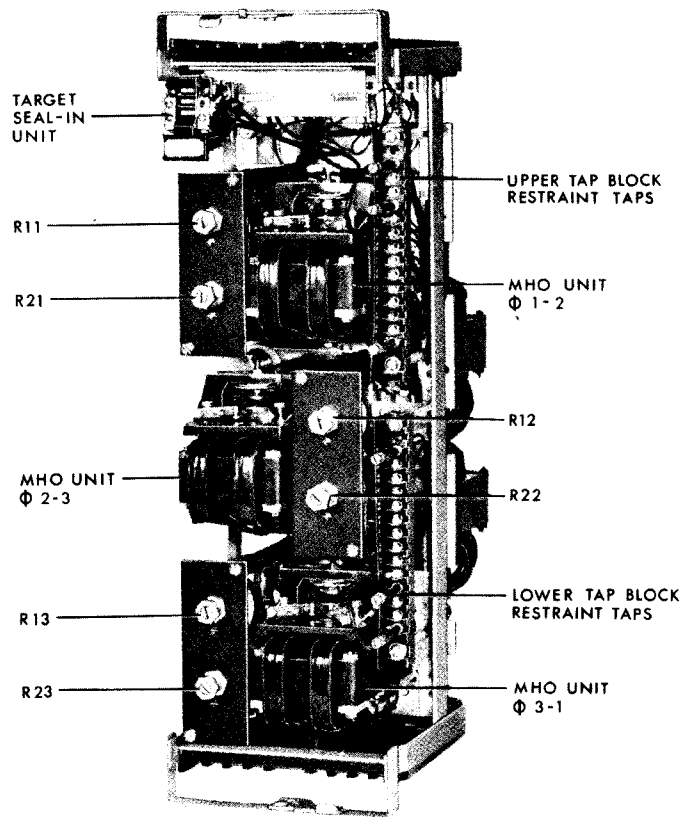

FIG. 1A (8036592) Front View

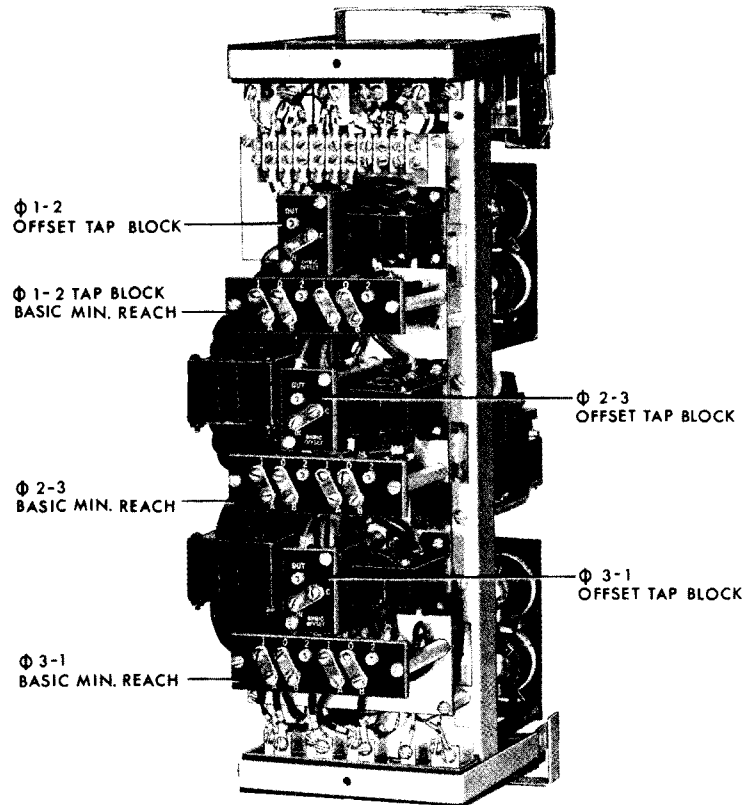

FIG. 1B (8036593) Back View

FIG. 1 Offset MHO Distance Relay CEB52A

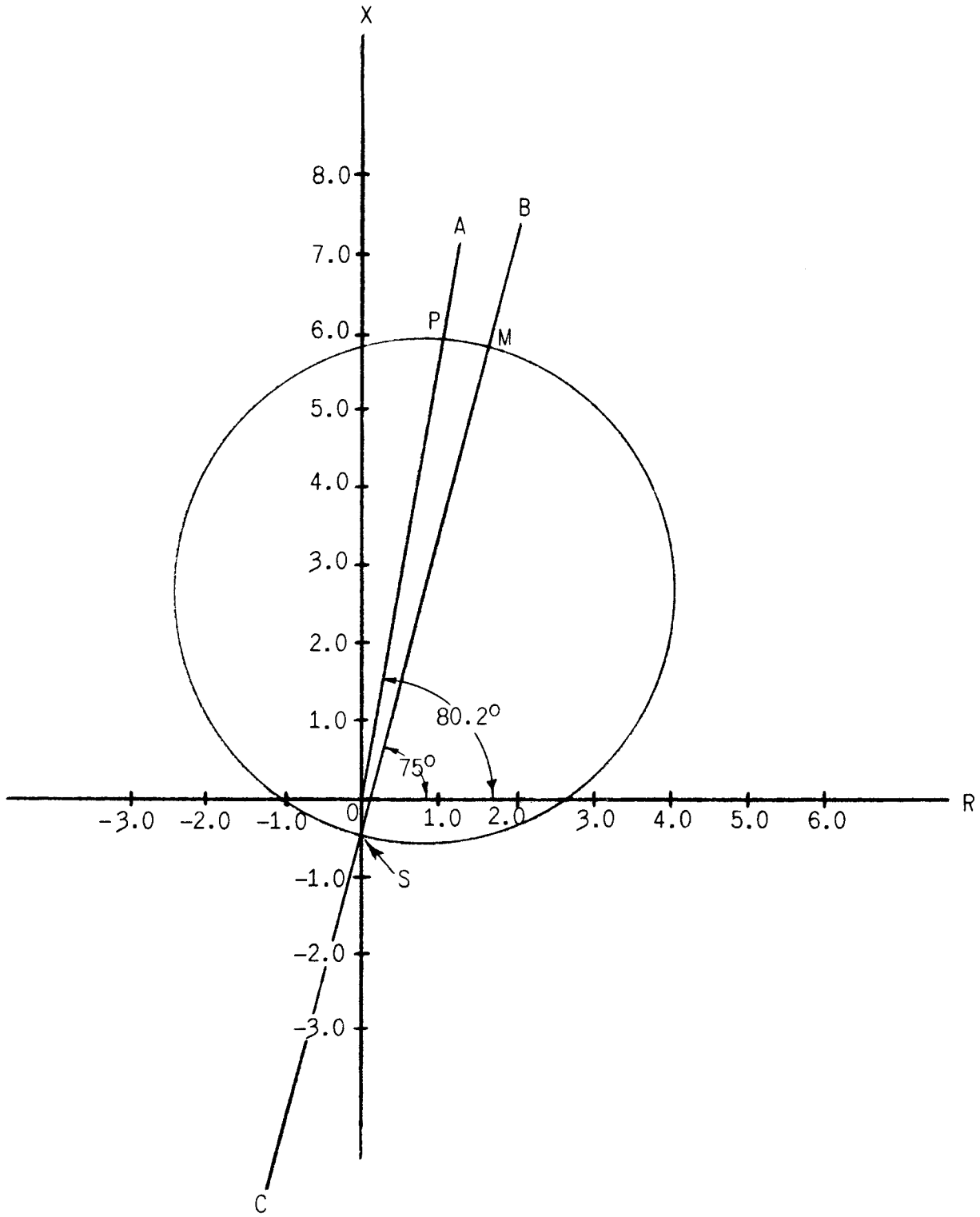

FIG. 2 (0127A9443-0) Graphical Construction of Offset MHO Diagram

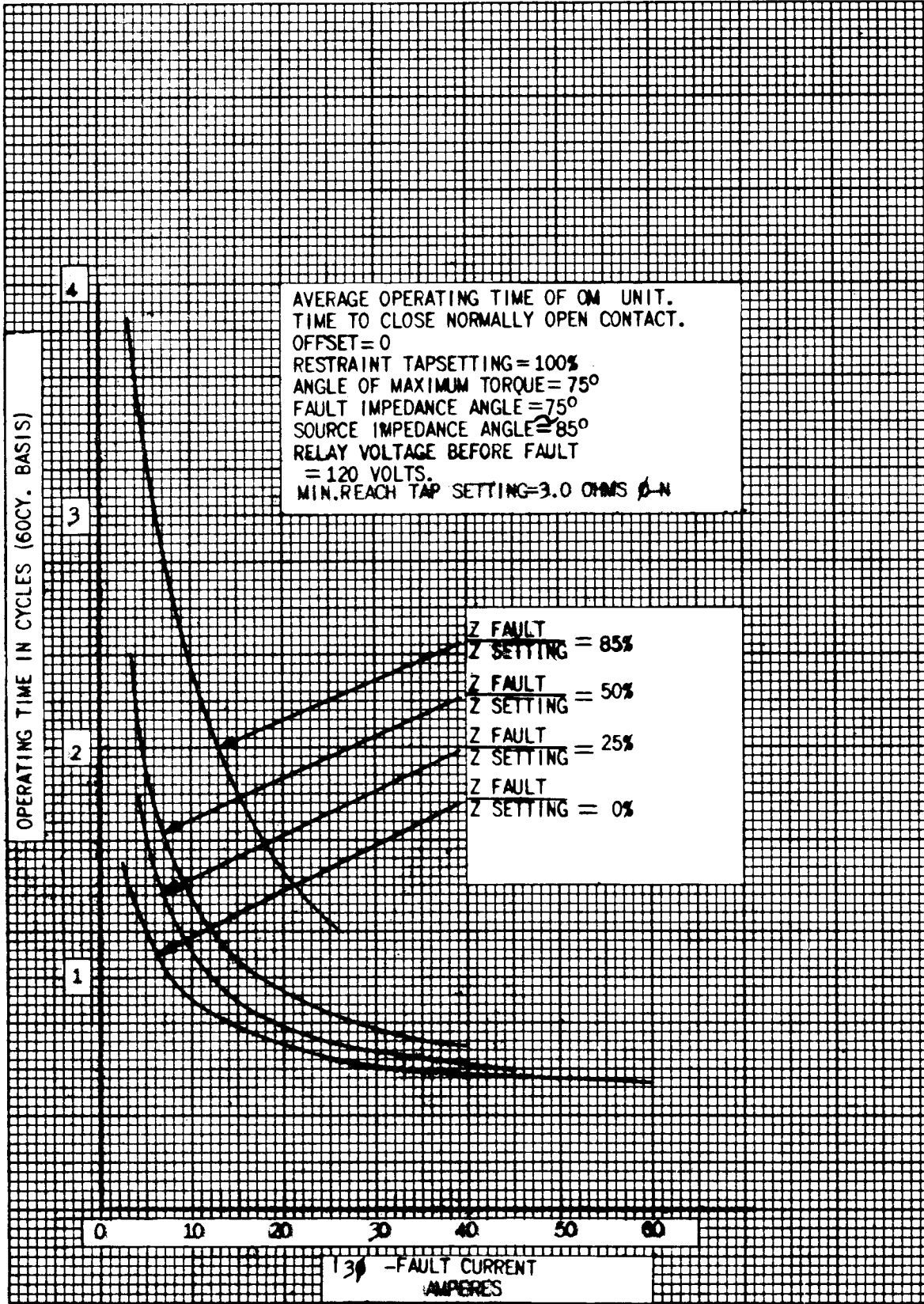

FIG. 9 (0203A8549-0) Operating Time Curves for the OM Unit with the Zero Offset Showing Time to Close Normally Open Contact

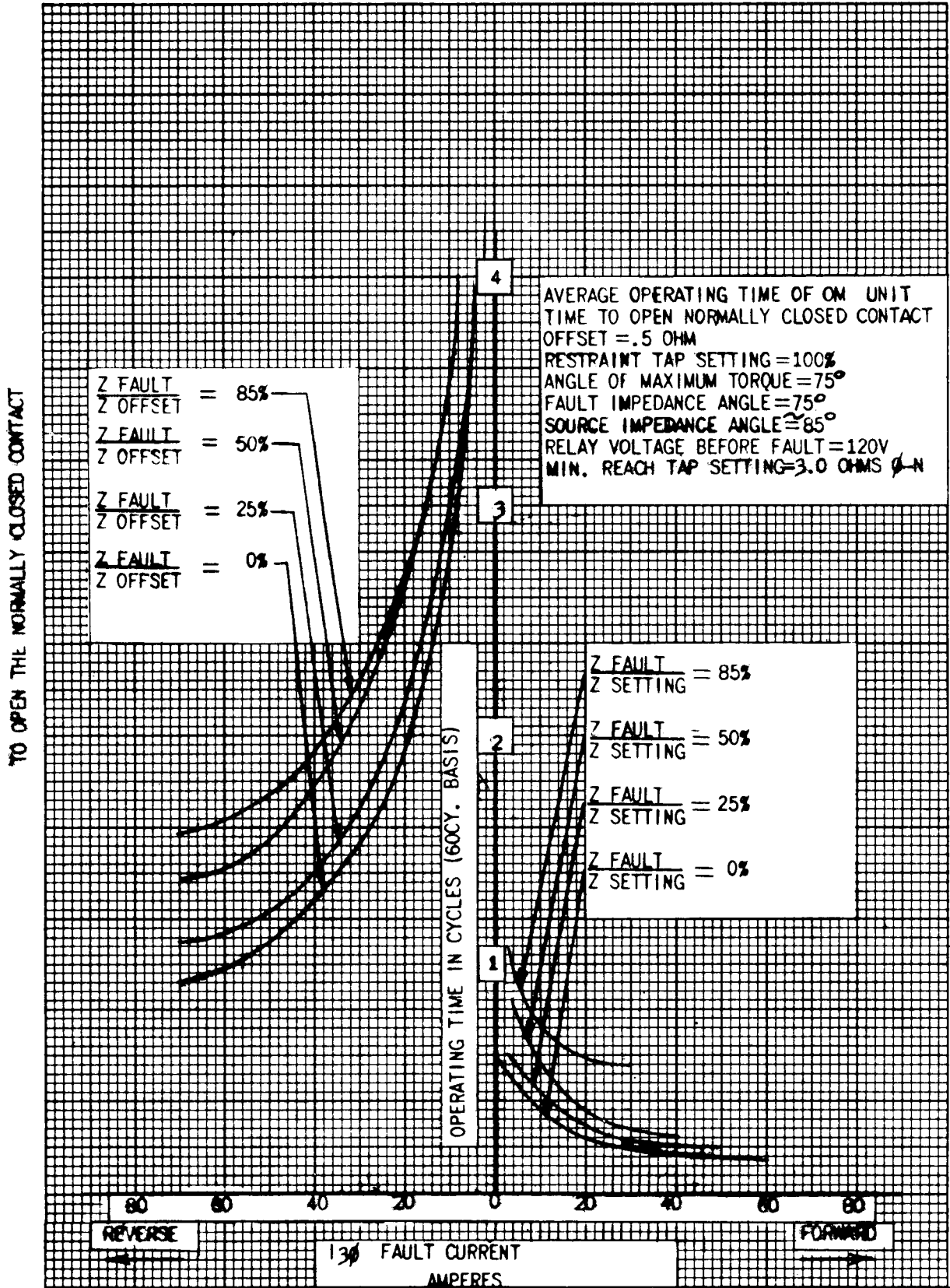

FIG. 10 (0203A8550-1) Operating Time Curves for the OM Unit with 0.5 Ohm Offset Showing Time to Open the Normally Closed Contact

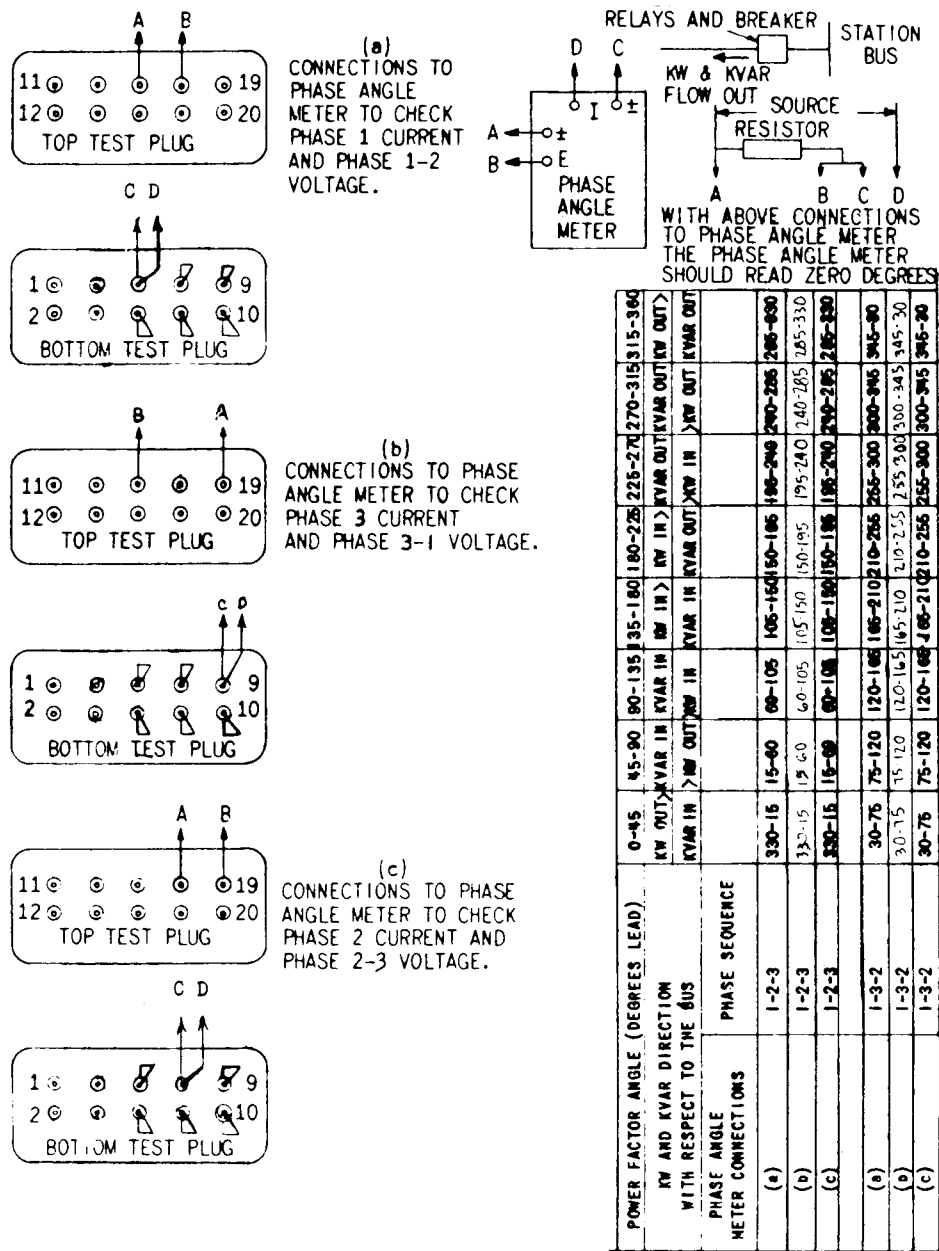

Fig. 15 (0195A4993-1) Overall Test Connections for Checking of External Wiring to Relay

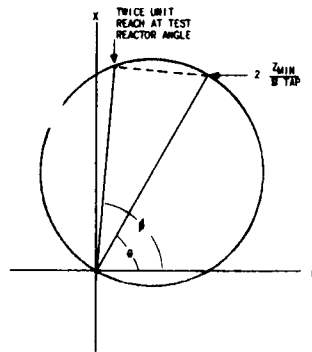
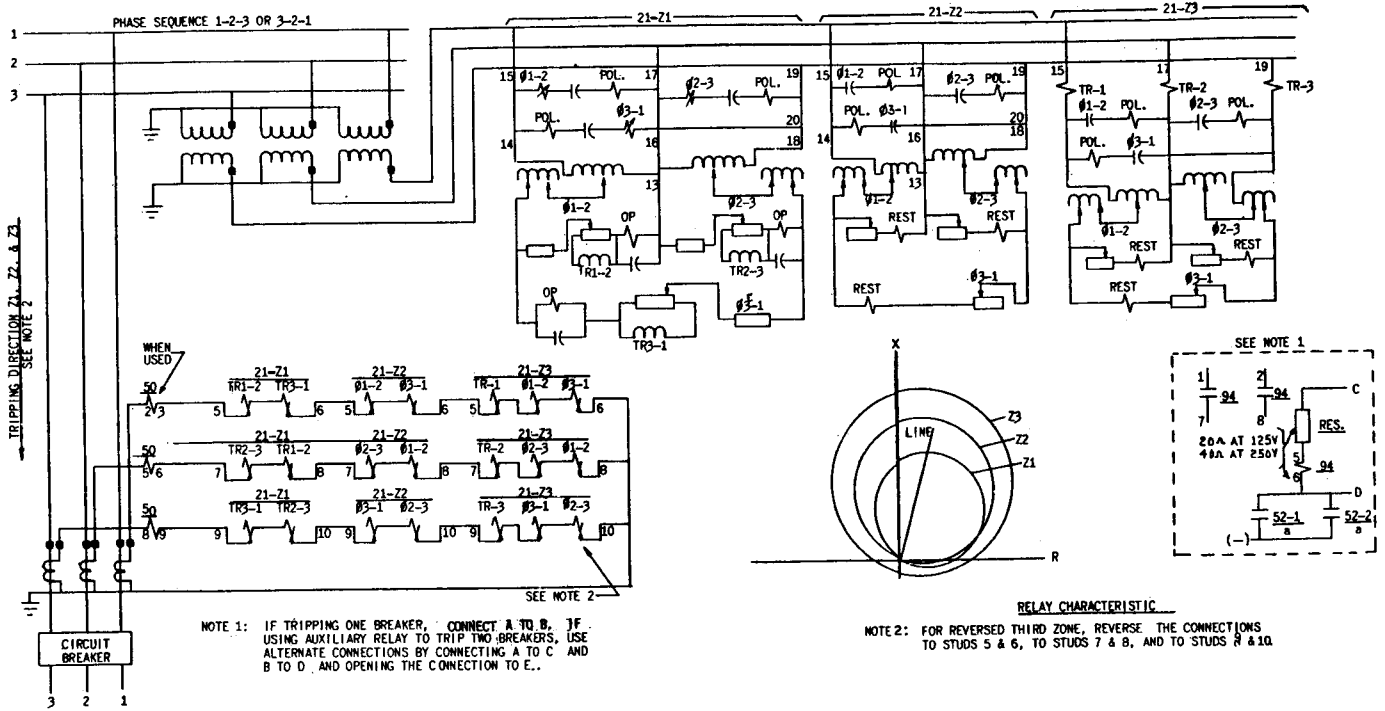

FIG. 16 (0195A4992-0) Diagram Showing Reach of MHO Units at the Angle of the Test Reactor



| DEVICE NO. | DEVICE TYPE | INCL. ELEM. | LEGEND DESCRIPTION |
|------------|-------------|-------------|----------------------------------|
| 21-21 | CEY51A | 3 | PHASE-1ST. ZONE MHO RELAY |
| | | # 1-2 | PHASE 1-2 UNIT ETC. |
| | | TR1-2 | PHASE 1-2 TRANSACTOR ETC. |
| | | T & S1 | TARGET & SEAL-IN UNIT |
| 21-22 | CEY52A | 3 | PHASE-2ND ZONE MHO RELAY |
| | | # 1-2 | PHASE 1-2 UNIT ETC. |
| | | T & S1 | TARGET & SEAL-IN UNIT |
| 21-23 | CEB52A | 3 | PHASE-3RD. ZONE OFFSET MHO RELAY |
| | | # 1-2 | PHASE 1-2 UNIT ETC. |
| | | TR-1 | PHASE 1 TRANSACTOR ETC. |
| | | T & S1 | TARGET & SEAL-IN UNIT |
| 21X | RPM21D | | TIMING RELAY |
| | TU | | TIMING UNIT |
| | TX | | AUXILIARY TO TIMING UNIT |
| 50 | PJC31C | | INSTANTANEOUS PHASE FAULT DET. |
| | | T & S1 | TARGET & SEAL-IN UNIT |
| 94 | HGA14 | AV | AUXILIARY TRIPPING RELAY |

| TABULATION OF DEVICES | | |
|------------------------|-----------------|-----------|
| TYPE OR DESCRIPTION | INTERNAL CONNS. | OUTLINE |
| CEY51A | 0178A7132 | 0168A7336 |
| CEY52A | 0178A7133 | 0178A7336 |
| CEB52A | 0178A7134 | 0178A7336 |
| RPM21D | 0127A9440 | K-6209271 |
| PJC31C | K-6375726 | K-6209272 |
| HGA14M (BACK CONNS.) | K-6400533 | K-6400533 |
| HGA14AL (FRONT CONNS.) | 377A139 | 377A139 |

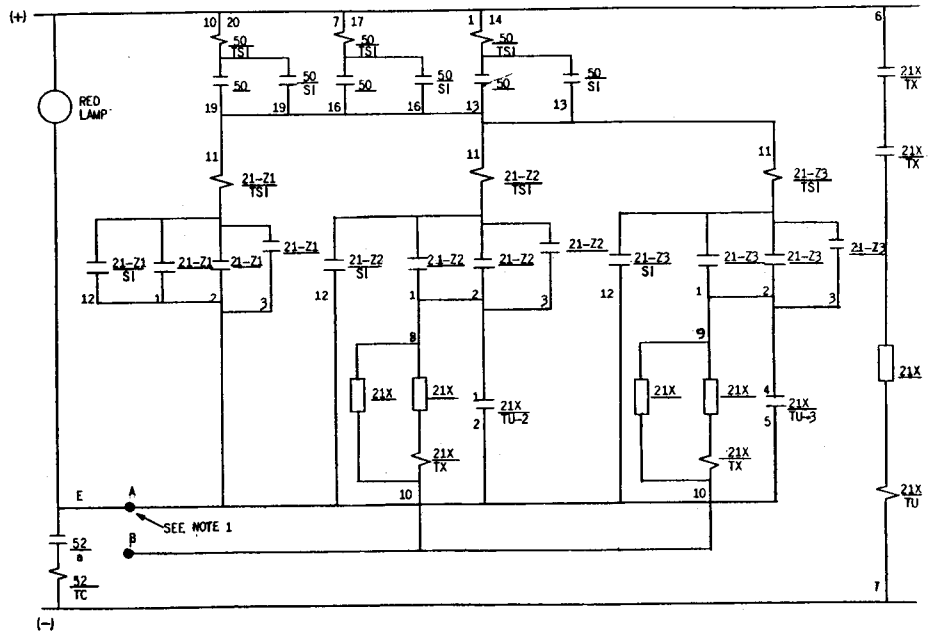
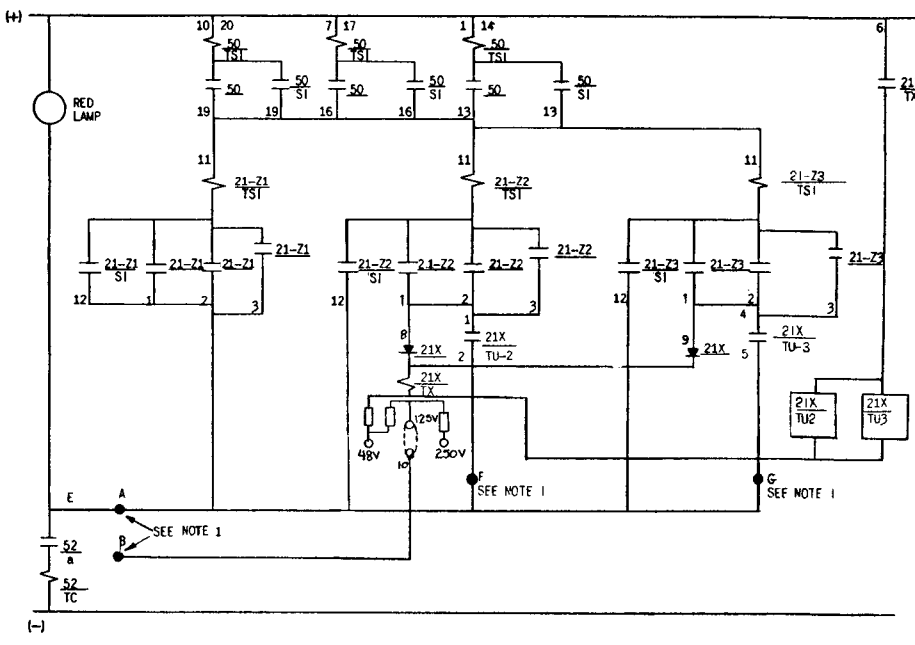
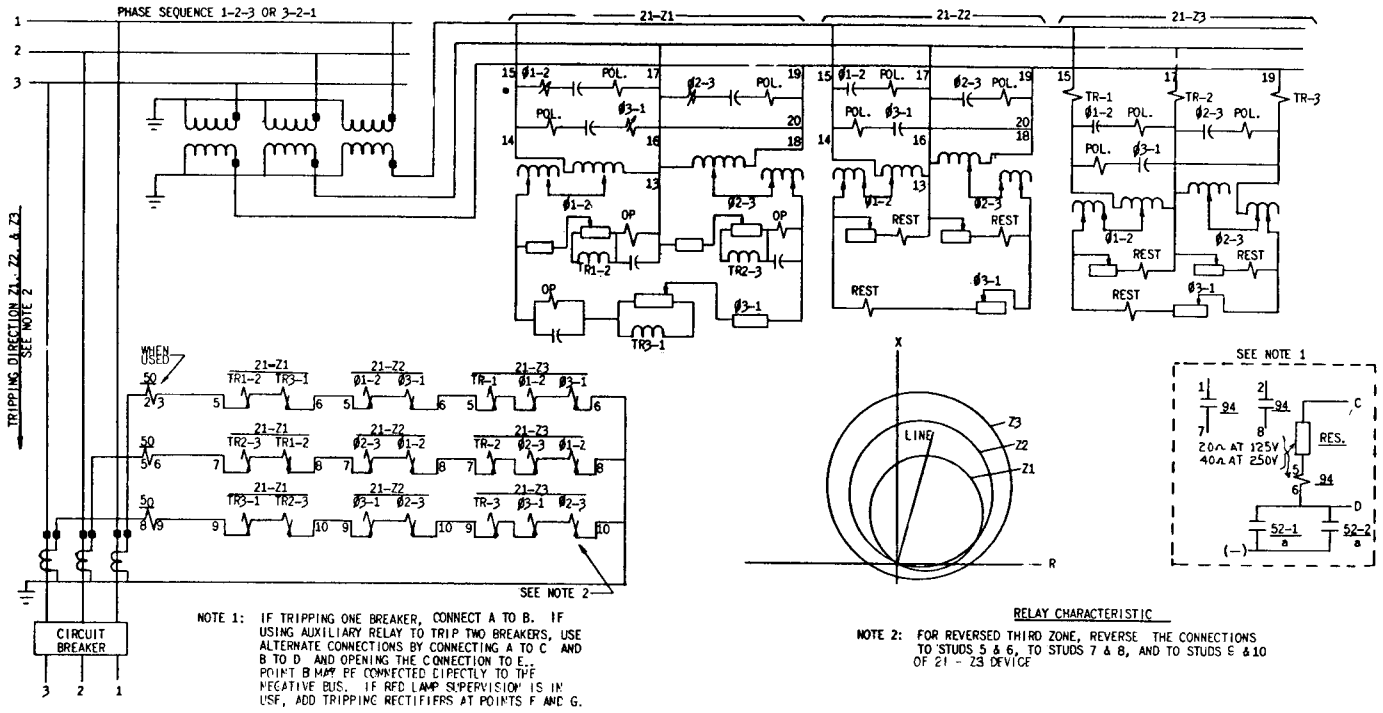

Fig. 17 (0116B9309 [5]) Typical External Connection Diagram Using CEY51A, CEY52A, CEB52A and RPM21D Relays Three Zone Distance Protection



| DEVICE NO. | DEVICE TYPE | INCL. ELEM. | DESCRIPTION |
|------------|-------------|-------------|-----------------------------------|
| 21-21 | CEY51A | | 3 PHASE-1ST ZONE WHO RELAY |
| | | | Ø 1-2 PHASE 1-2 UNIT ETC. |
| | | | TR1-2 PHASE 1-2 TRANSACTOR ETC. |
| | | | T & SI TARGET & SEAL-IN UNIT |
| 21-22 | CEY52A | | 3 PHASE-2ND ZONE WHO RELAY |
| | | | Ø 1-2 PHASE 1-2 UNIT ETC. |
| | | | T & SI TARGET & SEAL-IN UNIT |
| 21-23 | CEB52A | | 3 PHASE-3RD ZONE OFFSET WHO RELAY |
| | | | Ø 1-2 PHASE 1-2 UNIT ETC. |
| | | | TR-1 PHASE 1 TRANSACTOR ETC. |
| | | | T & SI TARGET & SEAL-IN UNIT |
| 21X | SAM16A | | TIMING RELAY |
| | | | TU TIMING UNIT |
| | | | TX AUXILIARY TO TIMING UNIT |
| 50 | PJC31C | | INSTANTANEOUS PHASE FAULT DET. |
| | | | T & SI TARGET & SEAL-IN UNIT |
| 94 | HGA14 | Amorall | AUXILIARY TRIPPING RELAY |

| TABULATION OF DEVICES | | |
|------------------------|-----------------|-----------|
| TYPE OR DESCRIPTION | INTERNAL CONNS. | OUTLINE |
| CEY51A | 0178A7132 | 0168A7326 |
| CEY52A | 0178A7133 | 0178A7326 |
| CEB52A | 0178A7134 | 0178A7336 |
| SAM16A | | K-6209271 |
| PJC31C | K-6375726 | K-6209272 |
| HGA14AM (BACK CONNS.) | K-6400533 | K-6400533 |
| HGA14AL (FRONT CONNS.) | 377A139 | 377A139 |

FIG. 18 (0116B9333-5) Typical External Connection Diagram Using CEY61A, CEY52A, CEB52A and SAM16A Relays Three Zone Distance Protection

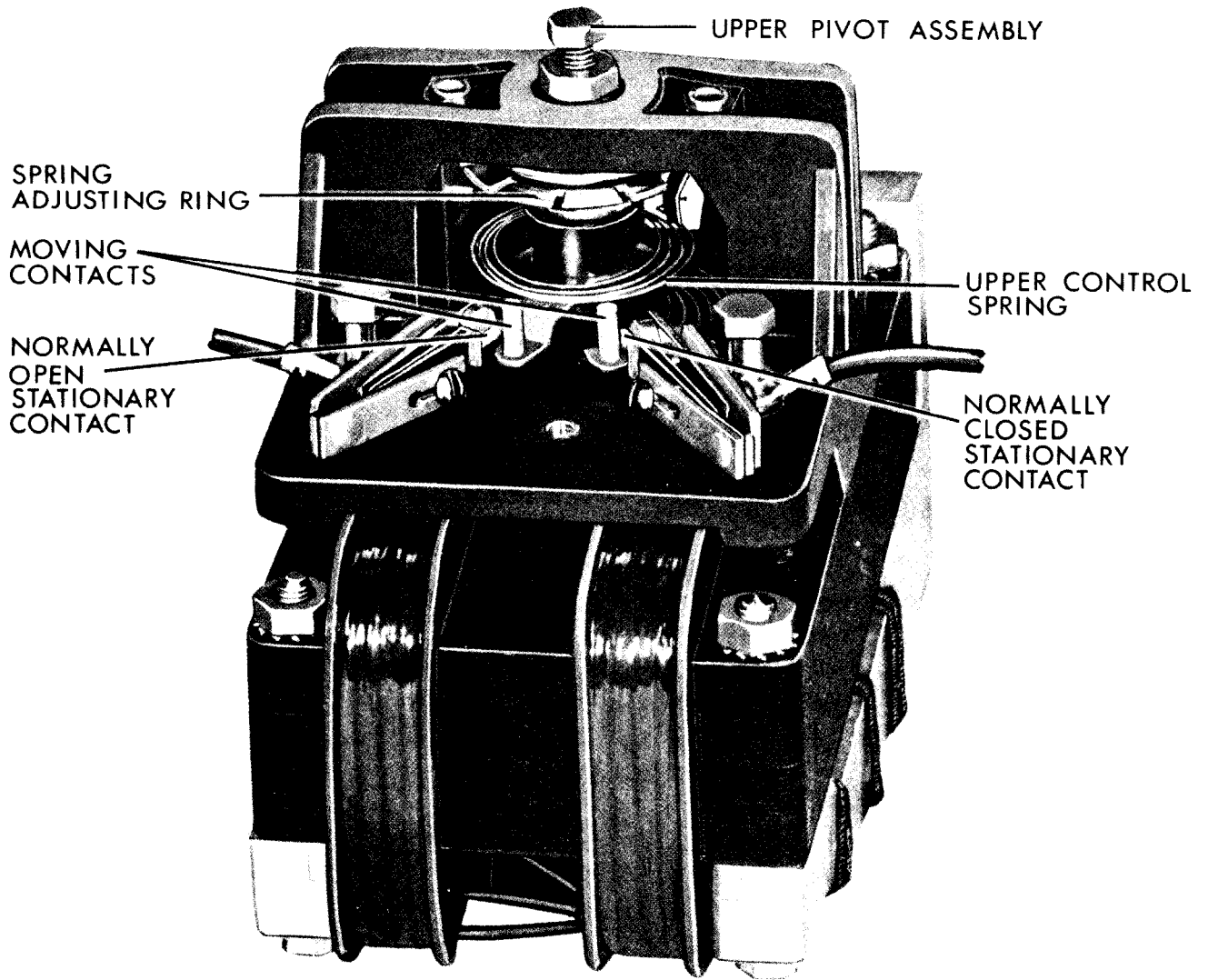

FIG. 19 (8041447) Four Pole Induction Cylinder Unit Typifying Construction of the MHO Units in the CEB52 Relay

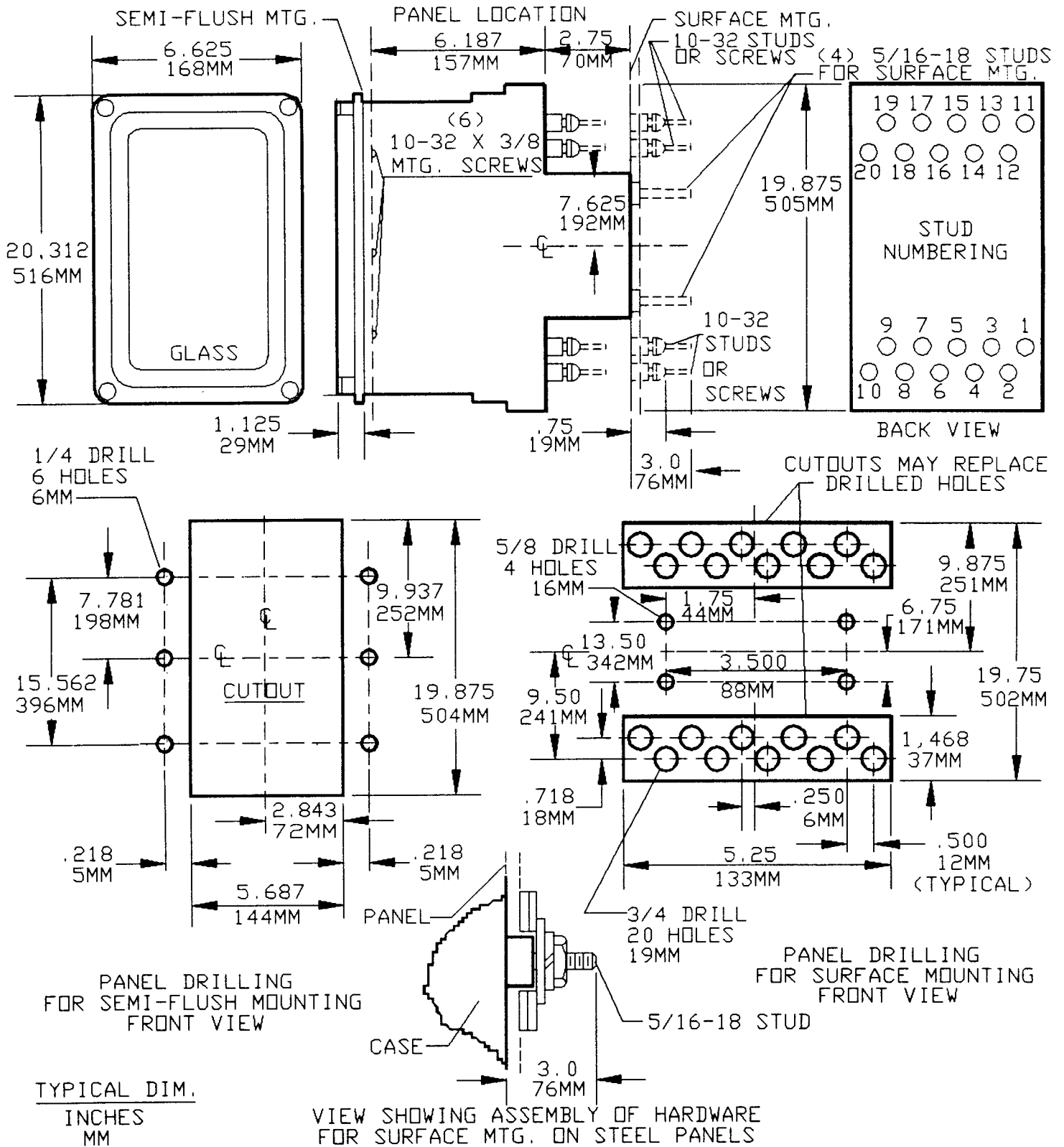

Figure 20 (0178A7336 [6]) OUTLINE & Panel Drilling for the Type CEB52 Relay