

INSTRUCTIONS

GEK-34171A



INSTANTANEOUS OVERCURRENT RELAY

TYPE CFC17A

GENERAL  ELECTRIC

TARGET SEAL-IN COIL RATINGS		
Conditions	Nominal Tap Rating (Amps)	
	0.2	2.0
Continuous Rating	0.3 Amps	3.5 Amps
DC Resistance	7.0 Ohms	0.13 Ohms
Tripping Duty	5.0 Amps	30.0 Amps

The tap setting used on the seal-in unit is determined by the current drawn by the trip coil. The 0.2 ampere tap is for use with trip coils that operate on currents ranging from 0.2 up to 2 amperes at the minimum control voltage. If this tap is used with trip coils requiring more than two amperes, there is a possibility that the seven ohms resistance will reduce the current to so low a value that the breaker will not be tripped.

The 2.0 ampere tap should be used with trip coils that take 2.0 amperes or more at minimum control voltage, providing the tripping current does not exceed 30 amperes at the maximum voltage. If the tripping current exceeds 30 amperes, an auxiliary relay should be used, the connections being such that the tripping current does not pass through the contacts or the target seal-in coil of the protective relay.

CHARACTERISTICS

The overcurrent unit is an induction cylinder device for alternating current circuits. The principle by which torque is developed is the same as that employed in an induction disk relay with a watt-hour meter element, though in arrangement of parts, it is more like a split phase induction motor. The induction cylinder type construction provides higher torque and lower rotor inertia than induction disk construction, making these relays faster and more sensitive than the induction disk type.

The overcurrent units have a 4 to 1 range of pick-up, continually adjustable by means of an adjusting ring that winds or unwinds a spiral control spring affixed to the moving cup type assembly.

The operating characteristics of these units are shown by the TIME-CURRENT CURVES of Figure 3.

BURDENS

The following table gives the burden of the current circuits per phase at 5 amperes 60 Hz.

RANGE OF PICKUP CURRENT	WATTS	VOLT-AMP
2-8	1.17	1.90
4-16	0.35	0.49
10-40	0.50	0.66
20-80	0.50	0.66

CALCULATION OF SETTINGS

When used in the ground relaying scheme outlined in the APPLICATION section, special considerations must be observed when determining the instantaneous overcurrent unit pickup setting. It must be remembered that single phase to ground current magnitudes supplied to the relay must be computed by adding the positive sequence component of fault current at the relay location to the negative sequence component of fault current at the relay location.

The phase to ground fault selector logic can provide CFC17A torque control permission for double phase to ground faults near the maximum reach setting of the CEYG51B mho units. This may cause an undesired trip output unless the mho unit reach and the instantaneous overcurrent unit "reach" are coordinated. For a phase 2-3 ground fault near the maximum reach setting of the ground mho units, phase 3-G mho unit tends to underreach while the phase 2-G mho unit tends to overreach. Phase 3-G mho unit might not see the fault while phase 2-G mho unit could see the fault. For this situation the scheme provides

torque control for a double phase to ground fault. To prevent an undesired trip output the CFC17A instantaneous overcurrent units must be set to "reach" shorter than the mho units. This should not present a problem since the CFC17A instantaneous overcurrent units are normally set as underreaching zone 1 functions while the CEYG51B mho units must necessarily be overreaching functions.

CONSTRUCTION

The construction of the relay consists of three instantaneous overcurrent cup units mounted one above the other. Each overcurrent unit has its own target seal-in element all contained in an L-2 type drawout relay case.

The target seal-in units are mounted at the upper left side of the overcurrent units. When operated by the overcurrent unit they pick-up and seal around the overcurrent unit. When the seal-in unit picks up it raises a target into view which latches up and remains exposed until released by pressing a button beneath the lower left corner of the relay case.

The stator of each unit has eight laminated magnetic poles arranged symmetrically around a central magnetic core. In the annular air gap between the poles and central core is the cylindrical part of the cup-like aluminum rotor, which turns freely in the gap. The central core is fixed to the stator frame; the rotor alone turns.

All eight poles have current windings. There are two groups of four coils connected in series. The four corner coils have an additional winding which consists of many turns of fine wire. A capacitor is connected across these four coils in series to produce a phase shift in the flux so as to produce torque. This floating circuit is brought out to studs so that the relay can be controlled by another device if desired.

The internal connection diagram is shown in Figure 1.

The contacts of the overcurrent units are especially constructed to suppress bouncing on the overcurrent units. See Figure 5 for the construction of this assembly. The stationary contact (G) is mounted on a flat spiral spring (F) backed up by a thin diaphragm (C). These are both mounted in a slightly inclined tube (A). A stainless steel ball (B) is placed in the tube before the diaphragm is assembled. When the moving contact hits the stationary contact, the energy of the former is imparted to the latter and thence to the ball, which is free to roll up the inclined tube. Thus, the moving contact comes to rest with substantially no rebound or vibration.

The relay components are mounted in a cradle assembly which is latched into a drawout case when the relay is in operation but it can easily be removed when desired. To do this, the relay is first disconnected by removing the connection plug which completes the electrical connections between the case block and the cradle block. To test the relay in its case this connection block can be replaced by a test plug. The cover, which is attached to the front of the relay case, contains the target reset mechanism and an interlock arm which prevents the cover from being replaced until the connection plugs have been inserted.

The relay case is suitable for either semi-flush or surface mounting on all panels up to two inches thick and appropriate hardware is available. However, panel thickness must be indicated on the relay order to insure that proper hardware will be included. For outline and drilling dimensions, see Figure 4. Every circuit in the drawout case has an auxiliary brush, to provide adequate overlap when the connecting plug is withdrawn or inserted. Some circuits are equipped with shorting bars and on these circuits it is especially important that the auxiliary brush makes contact to be sure the current coil is connected to the C.T. circuit before the shorting bar parts.

RECEIVING, HANDLING AND STORAGE

These relays, when not included as a part of a control panel, will be shipped in cartons designed to protect them against damage. Immediately upon receipt of a relay, examine it for any damage sustained in transit. If injury or damage resulting from rough handling is evident, file a damage claim at once with the transportation company and promptly notify the nearest General Electric Apparatus Sales Office.

Reasonable care should be exercised in unpacking the relay in order that none of the parts are injured or the adjustments disturbed. If the relays are not to be installed immediately, they should be stored in their original cartons in a place that is free from moisture, dust and metallic chips. Foreign matter collected on the outside of the case may find its way inside when the cover is removed and cause trouble in the operation of the relay.

Also check the nameplate stamping to insure that the model number and the rating of the relay received agree with the requisition.

ACCEPTANCE TESTS

MECHANICAL CHECKS

Inspect the relay for imperfections due to oversight or damage in transit in assemblies, or in terminal to cradle block, foreign particles, cracked molded parts etc.

Inspect overcurrent unit for proper shaft end play, contact gap and wipe:

End Play - 0.015" to 0.020"

Contact Gap - 1/32", one turn of contact barrel is equal to 1/32".

Contact Wipe - 0.005" to 0.010"

Check to see that the following cup unit locking assemblies are secure:

Upper Pivot Screw

Adjusting Ring Clamp

Clutch Locking Nut

Inner Core Locking Nut

Contact Barrel Locking Screw

Contact Stop Nut

TARGET SEAL-IN UNITS

Operate the armature by hand and note that the bridging contacts make about the same time and with some wiping action before the armature comes to rest against the pole piece. During this operation the target should come into view and latch up before the total travel is exhausted. The reset level should reset the target with some extra travel after the target resets.

ELECTRICAL TESTS

DRAWOUT RELAYS GENERAL

Since all drawout relays in service operate in their case, it is recommended that they be tested in their case or an equivalent steel case. In this way any magnetic effects of the enclosure will be accurately duplicated during testing. A relay may be tested without removing it from the panel by using a 12XLA13A test plug. This plug makes connections only with the relay and does not disturb any shorting bars in the case. Of course, the 12XLA12A test plug may also be used. Although this test plug allows greater testing flexibility, it also requires C.T. shorting jumpers and the exercise of greater care since connections are made to both the relay and the external circuitry.

POWER REQUIREMENTS GENERAL

All alternating current operated devices are affected by frequency. Since non-sinusoidal waveforms can be analyzed as a fundamental frequency plus harmonics of the fundamental frequency, it follows that alternating current devices (relays) will be affected by the applied waveform.

Therefore, in order to properly test alternating current relays it is essential to use a sine wave of current and/or voltage. The purity of the sine wave (i.e. its freedom from harmonics) cannot be expressed as a finite number for any particular relay, however, any relay using tuned circuits, R-L or RC networks, or saturating electromagnets (such as time overcurrent relays) would be essentially affected by non-sinusoidal waveforms.

Similarly, relays requiring dc control power should be tested using dc and not full wave rectified power. Unless the rectified supply is well filtered, many relays will not operate properly due to the dips in the rectified power. Zener diodes, for example, can turn off during these dips. As a general rule the dc source should not contain more than 5% ripple.

ELECTRICAL TESTS

OVERCURRENT PICKUP TESTS

When the relays leave the factory, the units are set to pick-up at the minimum value of the rated range of pickup using test connections shown by figure 6.

The pickup of the cup type overcurrent unit is controlled by a spiral spring assembly which is affixed to an adjustable ring with holes that facilitates its setting. The ring rests in a molded part and is securely clamped by a threaded hex stud. The maximum pick-up value of the adjustable range can be obtained with a control spring wind-up of about one turn.

CLUTCH TESTS

A clutch is provided in the moving assembly, the function of which is to permit the cup assembly to slip at certain levels of current to maintain good non-bounce contact action as well as preventing damage to the moving assembly. A screw at the side of the assembly controls the clutch pressure. Check to see that the clutch slip current for the rated range of pickup is as follows:

PICK-UP RANGE	AMPERES FOR CLUTCH SLIP
4 - 16	24 - 36
10 - 40	Must Not Slip At 30
20 - 80	Must Not Slip At 30

TARGET AND SEAL-IN UNIT

These units should operate at 80 to 100% of rated tap value.

INSTALLATION

LOCATION

The location should be clean and dry, free from dust and excessive vibration, and well lighted to facilitate inspection and testing.

MOUNTING

The relay should be mounted on a vertical surface. The outline and panel drilling for either surface or semiflush mounting is shown in Figure 4.

One of the mounting studs or screws should be permanently grounded by a conductor not less than No. 12 B&S gage copper wire or its equivalent.

CONNECTIONS

The Internal connection diagram for the CFC17A is shown in Figure 1.

ADJUSTMENTS

The relays are calibrated at the factory and should not require any further adjustment. If it is desired to check the operating units, follow the procedure outlined under MAINTENANCE.

INSPECTION

At the time of installation, the relay should be inspected for tarnished contacts, loose screws, or other imperfections. If any trouble is found, it should be corrected in the manner described under MAINTENANCE.

MAINTENANCE

The relays are adjusted at the factory, and it is advisable not to disturb the adjustments. If for any reason they have been disturbed, the following points should be observed in restoring them.

SHAFT AND BEARINGS

The lower jewel screw can be removed from the unit by means of an offset screw driver or an end wrench. The jewel may be tested for cracks by exploring its surface with the point of a fine needle.

When it is replaced, the lower jewel bearing should be screwed all the way until its head engages the end of the threaded core. The upper bearing should be adjusted to allow about 1/64 inch end play of the shaft.

CONTACT CLEANING

For cleaning fine silver contacts, a flexible burnishing tool should be used. This consists of a flexible strip of metal with an etched roughened surface, resembling in effect a superfine file. The polishing action is so delicate that no scratches are left, yet corroded material will be removed rapidly and thoroughly. The flexibility of the tool insures the cleaning of the actual points of contact.

Fine silver contacts should not be cleaned with knives, files, or abrasive paper or cloth. Knives or files may leave scratches which increase arcing and deterioration of the contacts. Abrasive paper or cloth may leave minute particles or insulating abrasive material in the contacts and thus prevent closing.

The burnishing tool described is included in the standard relay tool kit obtainable from the factory.

CONTACT ADJUSTMENT

Should it be necessary to change the stationary contact, remove the contact barrel as a complete unit after loosening the screw at the front of the contact block. Unscrew the cap. The contact spring may then be removed.

The moving contact may be removed by loosening the screw which secures it to the contact arm and removing it from under the screw head.

The contact gap may be adjusted by slightly loosening the screw at the front of the contact block, and should be loose enough to allow only the contact barrel to rotate in its sleeve. The contact gap should be 1/32". One turn of the barrel is equal to 1/32".

CALIBRATING PROCEDURE

Refer to Acceptance Tests.

PERIODIC CHECKS AND ROUTINE MAINTENANCE

It is recommended that a mechanical inspection and an operation test be performed at least annually. The interval of time for periodic checks on relays may vary depending upon the importance of the relay in the protective scheme and its environment, such as extreme heat, moisture, and fumes.

The periodic checks in general are aimed to detect the two factors that can render the relay inoperative, i.e. friction and contaminated contacts.

OVERCURRENT UNIT

With regard to the overcurrent units, a test for the minimum pickup value will check whether the unit has undergone any changes in the circuit structures as well as revealing any undue friction. Small incremental changes in current to cause the moving assembly to move away from the back stop toward the contact will reveal any tendency of binding. Comparing pickup values with the history of previous periodic checks is particularly useful in detecting whether the pickup value is tending to rise over the years, thereby giving an indication of impending trouble.

Slightly discolored contacts need not be cleaned, however, if the contacts become badly discolored, they should be dressed with a contact burnishing tool. Refer to CONTACT CLEANING under MAINTENANCE.

TARGET SEAL-IN UNITS

The unit used in the relays with D-C ratings and current operated devices, rated 0.2/2.0 amperes. These seal-in units should pick up at a value equal to or less than the tap rating. Upon picking up, the contacts should wipe fully, and the target should drop. Both tap ratings should be checked. In the process of transferring to the other tap, do not remove the screw from the tap being used first, rather, remove one of the screws from the opposite stationary contact and insert this in the other current tap. This procedure keeps the stationary contacts in their original position thereby preserving proper contact alignment.

RENEWAL PARTS

It is recommended that sufficient quantities of renewal parts be carried in stock to enable the prompt replacement of any that are worn, broken, or damaged.

When ordering renewal parts, address the nearest Sales Office of the General Electric Company and specify quantity required, name of the part wanted, and the complete model number of the relay for which the part is required.

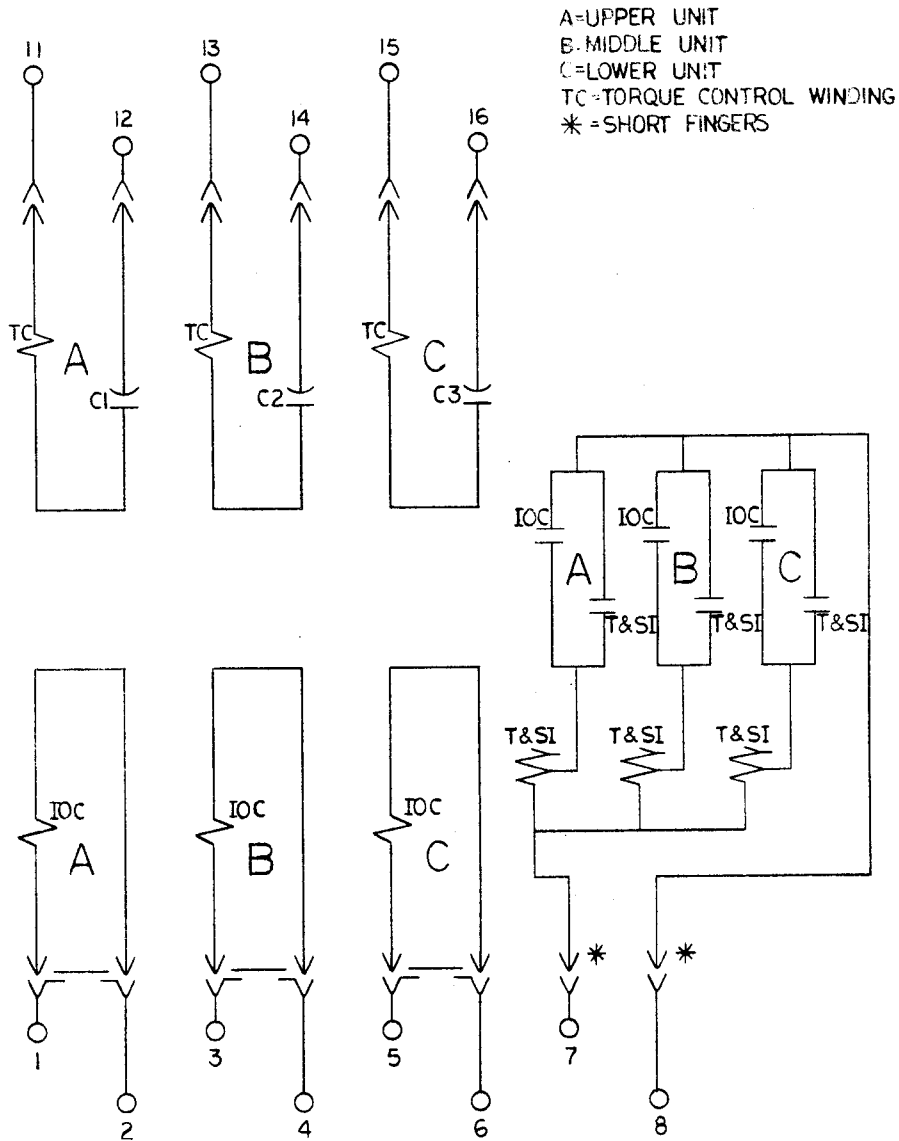

FIG. 1 (0246A3353-0) Internal Connection Diagram For Model 12CFC17A(-)A Relay

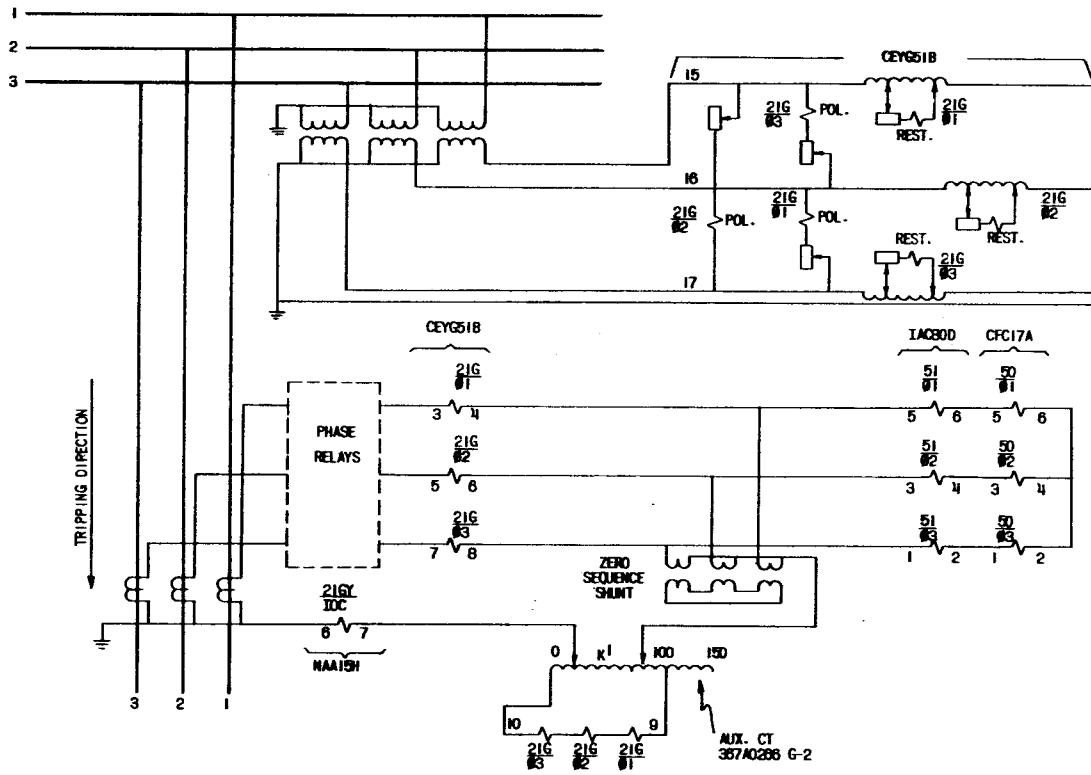

FIG. 2 (0165B2658-0 SH. 1) Elementary Diagram For Ground Fault Protection Scheme Showing External Connections For CFC17A

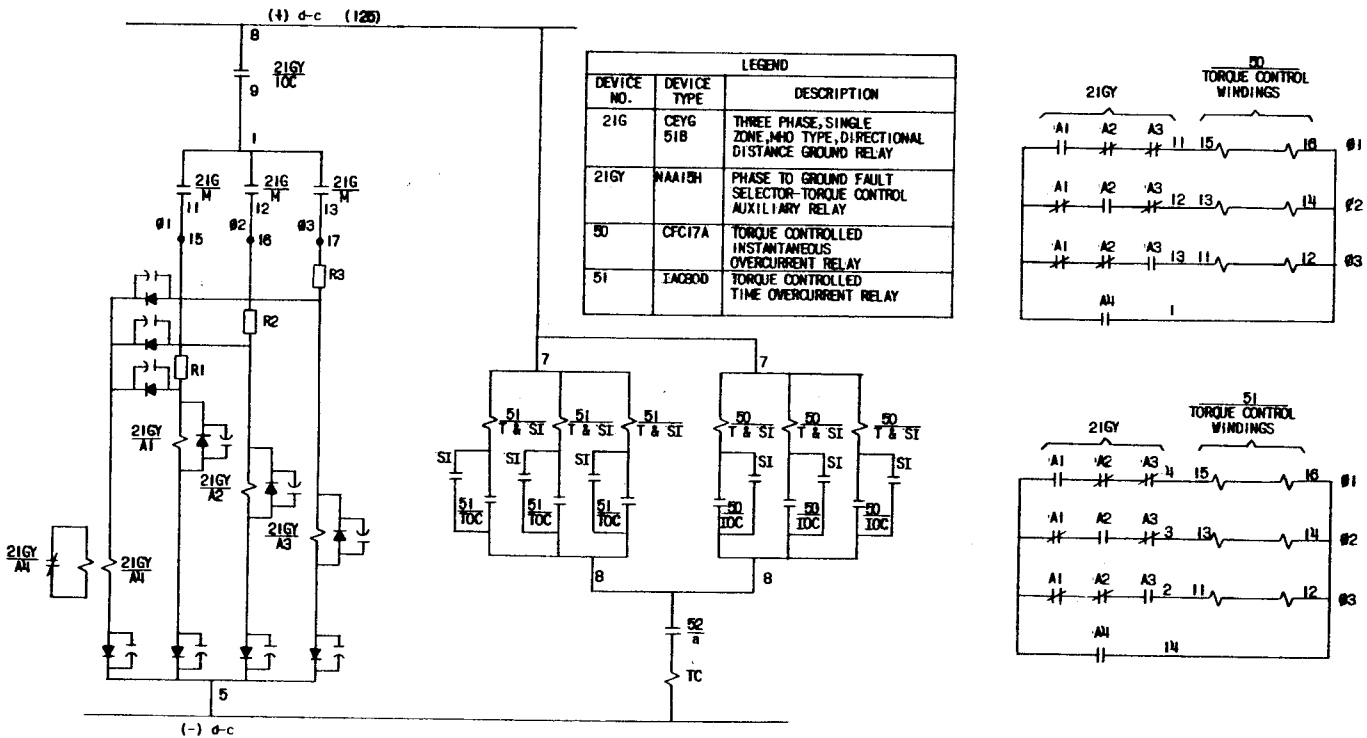

Fig. 2 (0165B2658 Sh.2) Elementary Diagram For Ground Fault Protection Scheme Showing External Connections For CFC17A

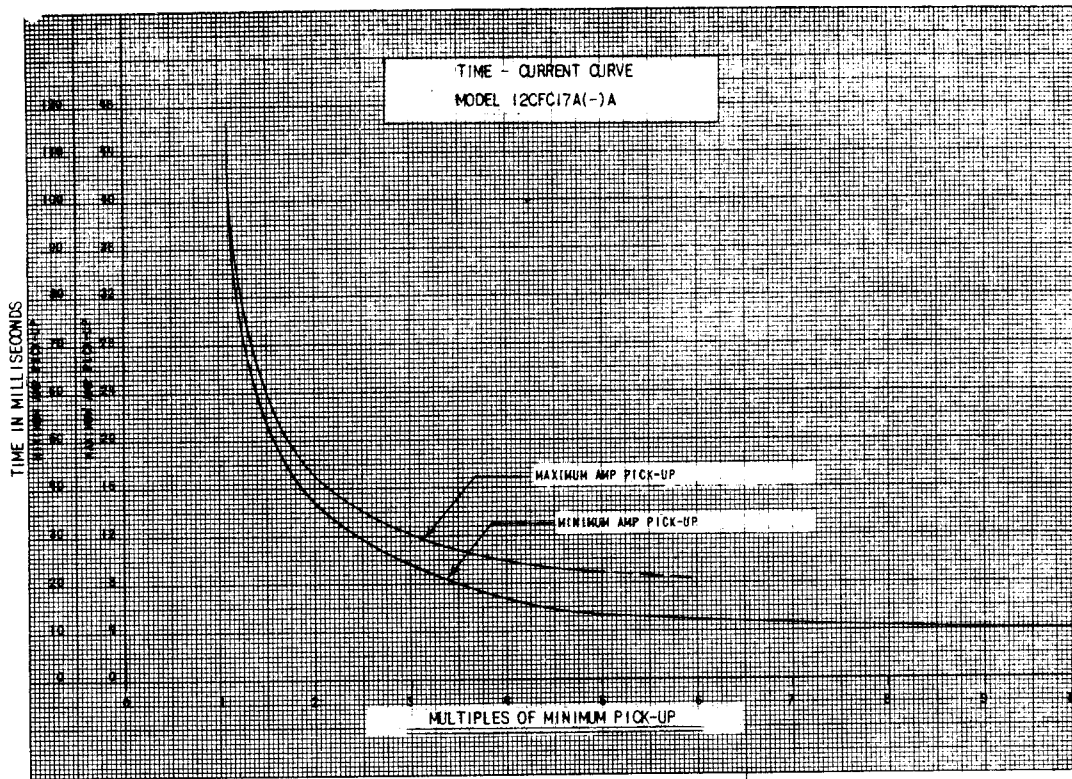
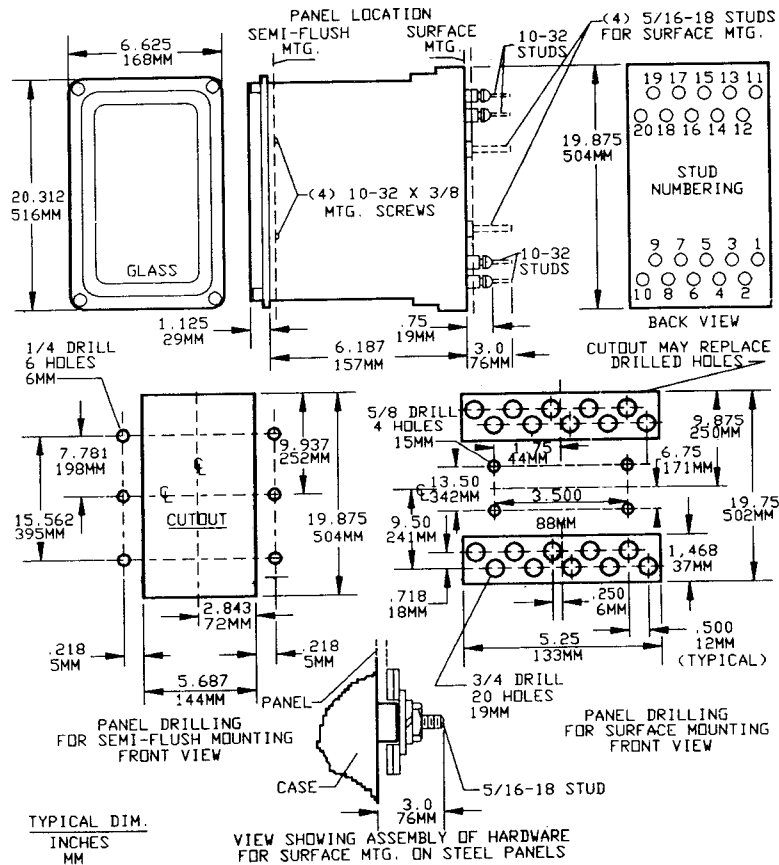
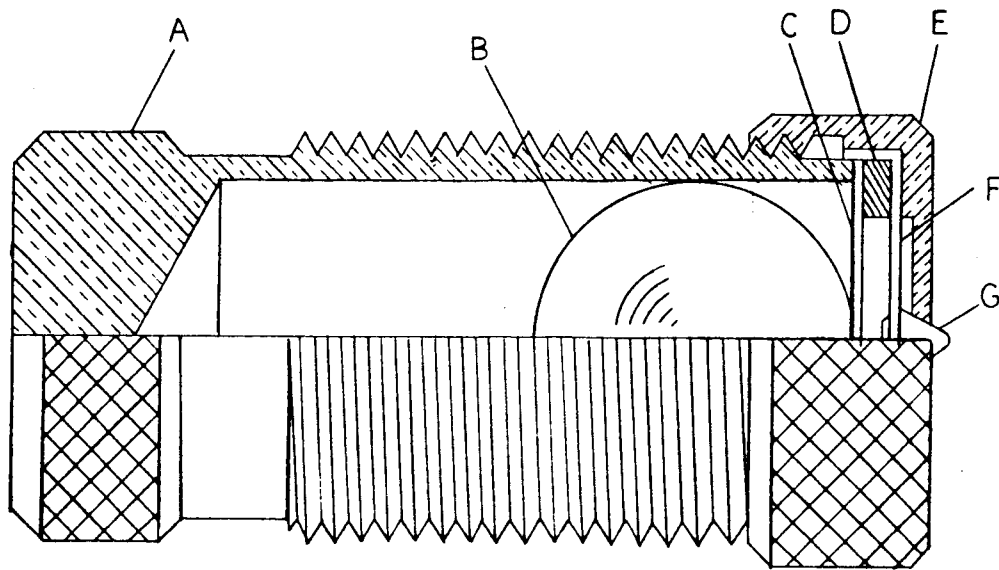

FIG. 3 (0246A7051-0) Time-Current Curves For Model 12CFC17A(-)A Relay



* Fig. 4 (K-6209276 [4]) Outline And Panel Drilling For Model 12CFC17A(-)A Relay

* Revised since last issue



- | | |
|--------------------------|------------------------|
| A - INCLINED TUBE | D - SPACER |
| B - STAINLESS STEEL BALL | E - CAP |
| C - DIAPHRAM | F - FLAT SPIRAL SPRING |
| G - CONTACT | |

* Fig. 5 K-6077069 [4]) Barrel Contact Assembly

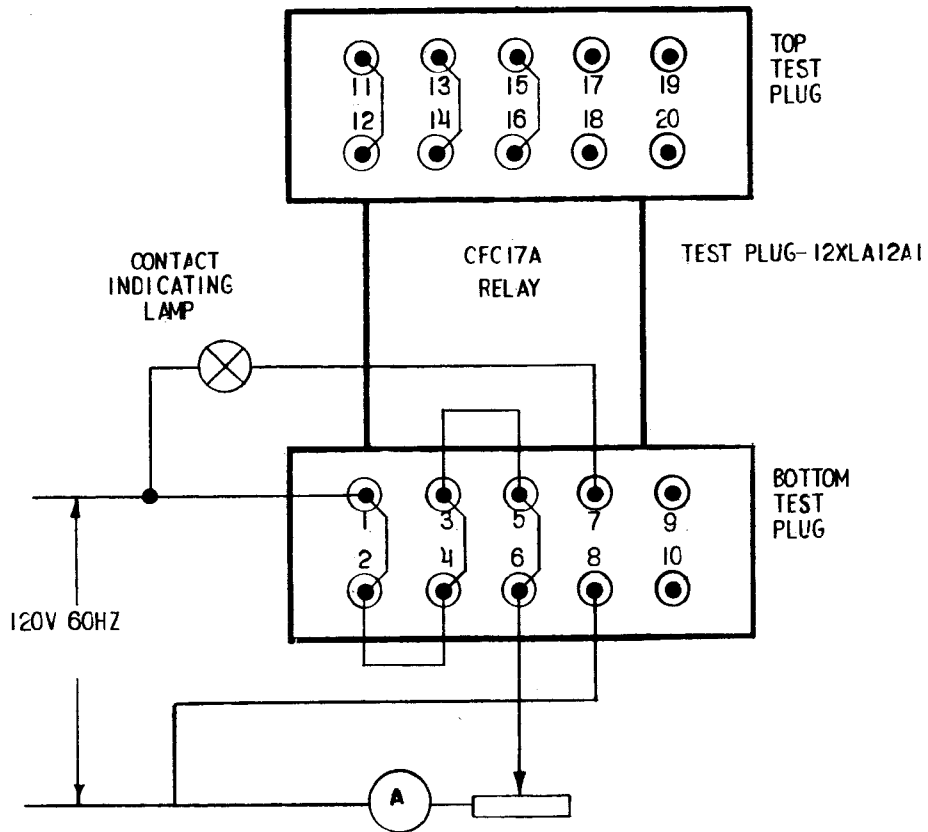

FIG. 6 (0246A6889-0) Test Connection Diagram For Model CFC17A(-)A Relay

* Revised since last issue