



INSTRUCTIONS

GEK-36827B
INSERT BOOKLET GEK-26400
Supersedes GEK-36827A

DC TIMING RELAY

TYPE SAM

MODEL 12SAM17C(-)A

INTRODUCTION

This instruction book, GEK-36827, together with instruction book GEK-26400 for the 12SAM16A12, 12SAM17A12 and 12SAM17B12 and up, provides instructions for the 12SAM17C(-)A relay.

DESCRIPTION

The 12SAM17C(-)A relay is similar to the 12SAM17B(-)A relay, except that the internal wiring was modified and the targets (T1-T2) were physically relocated in the relay. This was done so that it would have a more universally accepted wiring and physical location of the targets.

The original forms (forms 1-2-3) had internal connections similar to Figure 1 of this instruction book, except there were no 0.05 microfarad capacitors between Studs 6 and 10 and Studs 8 and 10.

Later the 0.05 microfarad capacitors were added to improve the surge capability of the relay. The new forms (Form 1 Rev. A, Form 2 Rev. A, and Form 3 Rev. A) had the internal connections shown by Figure 1 of this instruction book.

Later the above forms were obsoleted and replaced by Forms 11-12-13. The new forms have a diode and capacitor connected in series with the TX coil. The diode is in the circuit to break up a sneak circuit that occurs in some applications. The internal connection for these forms is shown in Figure 3 of this instruction book.

*Form 14 is similar to form 11 except that it is rated for 48/110/220 volts DC.

The outline and panel drilling for these relays is shown in Figure 12 of the attached instructions book, GEK-26400.

*Revised since last issue

These instructions do not purport to cover all details or variations in equipment nor provide for every possible contingency to be met in connection with installation, operation or maintenance. Should further information be desired or should particular problems arise which are not covered sufficiently for the purchaser's purposes, the matter should be referred to the General Electric Company.

To the extent required the products described herein meet applicable ANSI, IEEE and NEMA standards; but no such assurance is given with respect to local codes and ordinances because they vary greatly.

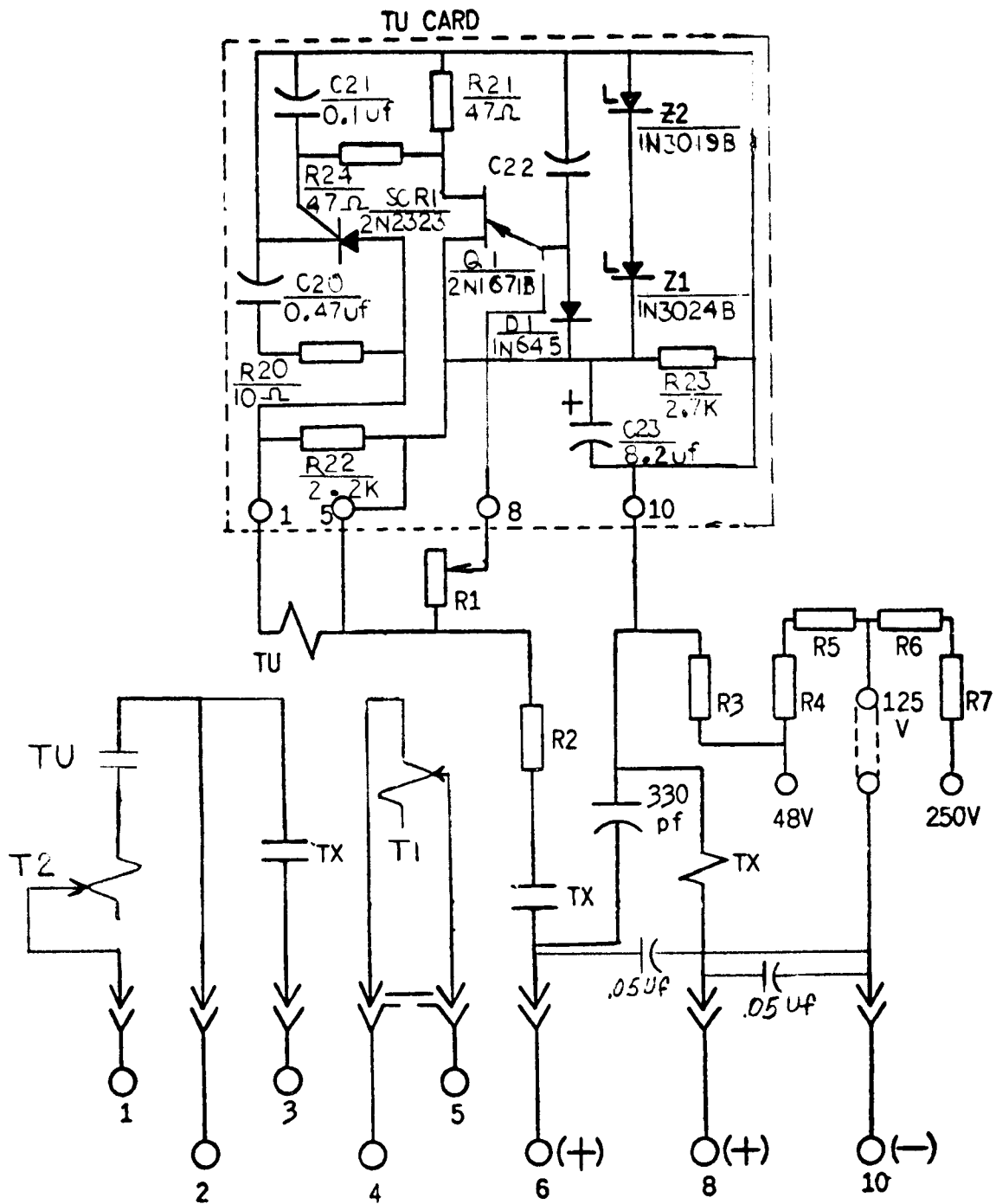

8 O = TIP NO ON PRINTED CIRCUIT CARD

Figure 1 (0227A7086 Sh.1 [3]) Internal Connections Diagram for the Type SAM17C Forms 1A-2A-3A

MODEL	FORM		
SAM 17C(-)A	1	2	3
VOLTS D.C.	48/125/250	48/125/250	48/125/250
TIME-SEC.	.05-3.0	0.1-5.0	.05-3.0
TAR. TAPS	1.0/4.0	1.0/4.0	0.2/2.0
RESISTANCE IN OHMS			
TX COIL	1300	1300	1300
TU COIL	650	650	650
R1	1.5 MEG	1.5 MEG	1.5 MEG.
R2	400	400	400
R3	60	60	60
R4	250	250	250
R5	250	250	250
R6	375	375	375
R7	375	375	375

TARGET BURDEN				
	0.2 AMP TAP	1.0 AMP TAP	2.0 AMP TAP	4.0 AMP TAP
MINIMUM OPERATING	0.2 AMPS	11.0 AMPS	2.0 AMPS	4.0 AMPS
CARRY CONTINUOUSLY	0.4 AMPS	2.5 AMPS	3.5 AMPS	6.0 AMPS
CARRY 30 AMPS FOR	-----	1.0 SEC.	4 SECS.	5.0 SEC.
CARRY 10 AMPS FOR	0.1 SEC.	10.0 SEC.	30 SECS.	50.0 SEC.
DC RESISTANCE	7 OHMS	0.25 OHMS	0.13 OHMS	0.034 OHM
60 CYCLE IMPEDANCE	52 OHMS	2.0 OHMS	0.53 OHMS	0.13 OHMS

Figure 2 (0227A7086 Sh.2 [1]) Resistance Values for the Type SAM17C Forms 1-2-3

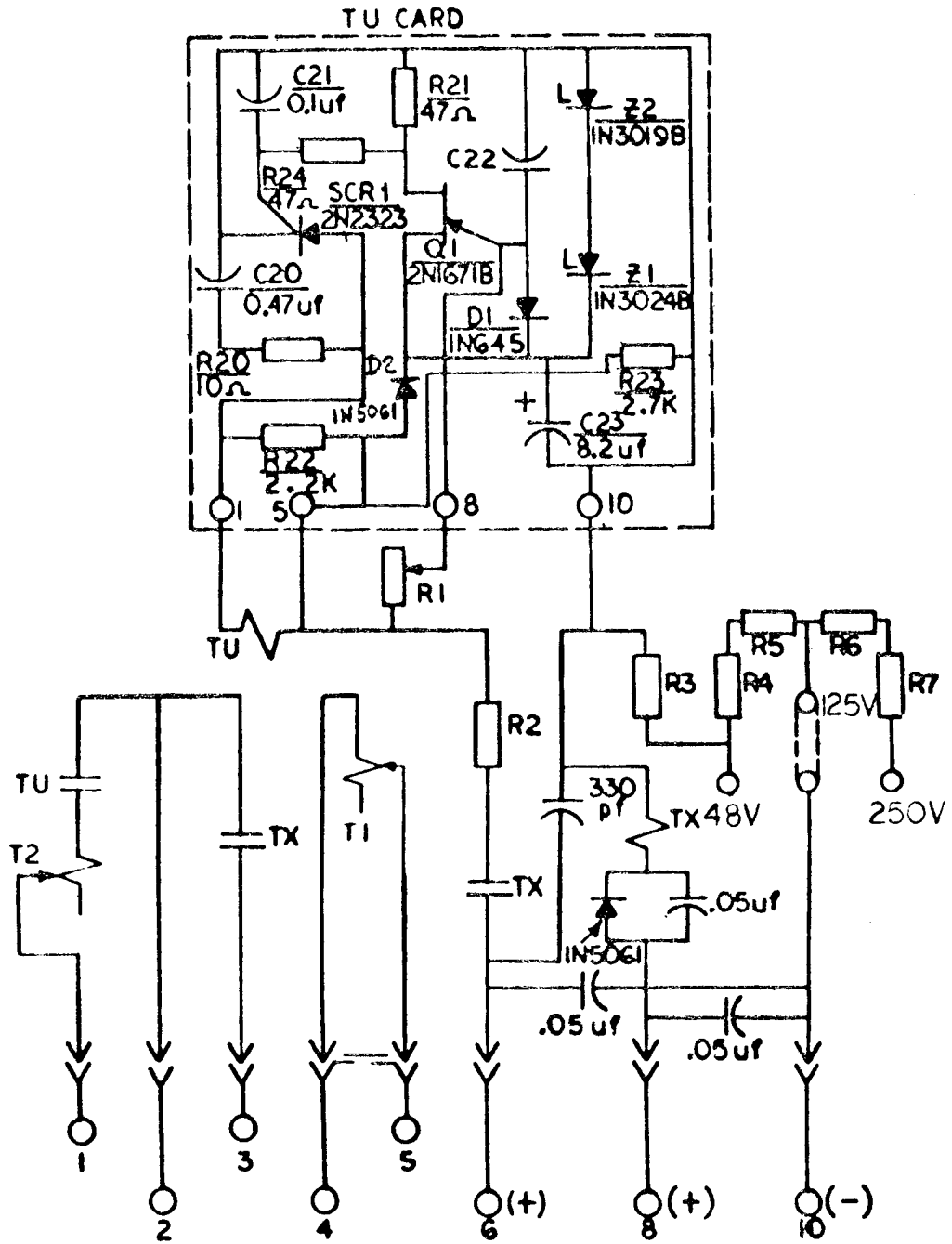

5 O = TIP NUMBER ON PRINTED CIRCUIT CARD

*Figure 3 (0269A3091 Sh.1 [3]) Internal Connection Diagram for the Type SAM17C Forms 11-12-13-14

*Revised since last issue

MODEL	FORM			
	11	12	13	14
SAM 17C(-)A	48/125/250	48/125/250	48/125/250	48/110/220
VOLTS D.C.	48/125/250	48/125/250	48/125/250	48/110/220
TIME-SEC.	.05-3.0	0.1-5.0	.05-3.0	.05-3.0
TAR. TAPS	1.0/4.0	1.0/4.0	0.2/2.0	1.0/4.0
RESISTANCE IN OHMS				
TX COIL	1300	1300	1300	1300
TU COIL	650	650	650	650
RESISTANCE IN OHMS				
R1	1.5 MEG.	1.5 MEG.	1.5 MEG.	1.5 MEG.
R2	400	400	400	400
R3	60	60	60	60
R4	250	250	250	350
R5	250	250	250	350
R6	375	375	375	500
R7	375	375	375	500

	TARGET BURDEN			
	0.2 AMP TAP	1.0 AMP TAP	2.0 AMP TAP	4.0 AMP TAP
MINIMUM OPERATING	0.2 AMPS	1.0 AMPS	2.0 AMPS	4.0 AMPS
CARRY CONTINUOUSLY	0.4 AMPS	2.5 AMPS	3.5 AMPS	6.0 AMPS
CARRY 30 AMPS FOR	-----	1.0 SEC.	4 SECS.	5.0 SEC.
CARRY 10 AMPS FOR	0.1 SEC.	10.0 SEC.	30 SECS.	50.0 SEC.
DC RESISTANCE	7 OHMS	0.25 OHMS	0.13 OHMS	0.034 OHM
60 CYCLE IMPEDANCE	52 OHMS	2.0 OHMS	0.53 OHMS	0.13 OHMS

*Figure 4 (0269A3091 Sh.2 [1]) Resistance Values for the Type SAM17C Forms 11-12-13-14

*Revised since last issue

***Meter and Control
Business Department***

(10)/89 (B)

General Electric Company
Protection and Control
205 Great Valley Parkway
Malvern, Pennsylvania 19355-0715