



# ***INSTRUCTIONS***

---

**MACHINE FIELD GROUND DETECTOR RELAY**

**TYPE PJG12B**

*GE Protection and Control  
205 Great Valley Parkway  
Malvern, PA 19355-1337*

The time-delay unit is enabled or disabled by means of a link. With the time-delay unit enabled the fault must remain for the pickup time of the thermal unit before the trip contacts will close. With the time-delay unit disabled there is no intentional time delay between fault inception and the closing of the trip contacts.

The PJG relay also includes a d-c supply. This supply is filtered and will introduce no more than three volts peak-to-peak ripple. The filter capacitor may be disconnected by moving the capacitor lead to stud 3A.

#### RECEIVING, HANDLING AND STORAGE

These relays, when not included as a part of a control panel, will be shipped in cartons designed to protect them against damage. Immediately upon receipt of a relay, examine it for any damage sustained in transit. If injury or damage resulting from rough handling is evident, file a damage claim at once with the transportation company and promptly notify the nearest General Electric Apparatus Sales Office.

Reasonable care should be exercised in unpacking the relay in order that none of the parts are injured or the adjustments disturbed.

If the relays are not to be installed immediately, they should be stored in their original cartons in a place that is free from moisture, dust and metallic chips. Foreign matter collected on the outside of the case may find its way inside when the cover is removed and cause trouble in the operation of the relay.

#### ACCEPTANCE TESTS

Immediately upon receipt of the relay an inspection and acceptance test should be made to insure that no damage has been sustained in shipment and that the relay calibrations have not been disturbed.

These tests may be performed as part of the installation or acceptance test at the discretion of the user.

Since most operating companies use different procedures for acceptance and installation tests, the following section includes all applicable tests that may be performed on these relays.

#### VISUAL INSPECTION

Check the nameplate stamping to insure that the model number and rating of the relay agree with the requisition.

Remove the relay from its case and check that there are no broken or cracked molded parts or other signs of physical damage, and that all screws are tight.

#### MECHANICAL INSPECTION

##### Cradle and Case Blocks

Check that the fingers on the cradle and the case agree with the internal connection diagram. Check that the shorting bars are in the correct position. Check that each finger with a shorting bar makes contact with the shorting bar. Deflect each contact finger to insure that there is sufficient contact force available. Check that each auxiliary brush is bent high enough to contact the connection plug.

Check that the A unit plunger moves freely up and down within the calibration tube (do not change calibration), and contacts make correctly. The AX armature should operate so that contacts make before break and wires to moving contacts do not interfere with movement. The AY target armature should set the target and close its contacts uniformly.

Put the relay into its case. It should slide in without excessive binding. No wires should be pinched between case and cradle. Set the target by hand. Target should be clearly displayed. Place the glass cover on the relay case (reset button on lower left) and fasten in position with thumbscrews. Pressing the reset button slowly should cause the microswitch to "click" before the target drops.

#### ELECTRICAL CHECKS

Any electrical testing of the relay must occur in a case which is perfectly level in the upright position. Place the time-delay link on "In" position. Apply rated voltage to studs 9-10, insert the connection plug, and fasten glass cover. Placing a jumper across studs 3-4 should cause the relay to operate in  $2 \pm 0.5$  seconds (target appears). Remove the jumper. Pressing the lower left reset button after a minimum of two minutes causes the target to drop. Remove the glass cover, and pull out the connection plug. Place the time-delay link to "Out" position. Reinsert the connection plug, fasten the cover into position.

Placing a jumper across studs 3-4 should cause the target to appear instantaneously. Remove the jumper and press the reset button. The target should drop.

If readjustment is found to be necessary, refer to the section titled SERVICING.

### INSTALLATION PROCEDURE

#### LOCATION AND MOUNTING

The relay should be mounted on a vertical surface in a location reasonably free from excessive heat, moisture, dust and vibration. The relay case may be grounded, if desired, using at least No. 12 AWG gage copper wire. The outline and panel drilling diagram for the Type PVD relays is shown in Fig. 1.

#### CONNECTIONS

The internal connection diagrams for the Type PJG12B relay is shown in Fig. 3. The elementary diagram of the external connections for a typical application is shown in Fig. 5.

Note that the transformer is connected for the proper a-c voltage; see Fig. 3 before energizing relay.

#### MOUNTING

The relay should be mounted on a vertical surface in a location that is clean and dry, free from excessive vibration, and well lighted to facilitate inspection and testing. It must be emphasized that the relay case is vertically upright and level. The case has provisions for either flush or semi-flush mounting. An assortment of hardware is provided for either mounting. Refer to Fig. 8 for outline and panel drilling dimensions.

#### MECHANICAL SETTINGS

Before any mechanical or electrical adjustments are made, the subsections titled VISUAL CHECKS AND MECHANICAL CHECKS should be followed. Additional attention must be given toward contact settings.

For the A plunger unit, the flexible contact lead should be formed such that it does not touch molded parts. It should be shaped such that movement is only at the terminals and the "a" contact makes without the moving contact missing the fixed contact. Contact gap should be 3/32 inch from fixed to moving contact.

For the AX hinged armature unit, contact gap for the normally closed contacts should be at least 1/16 inch when operated by hand. The normally open contact must close before the normally closed contacts open (make before break). Contact gap is approximately 1/8 inch.

For the AY hinged armature target unit, operation by hand should cause the two contacts to close at approximately the same time. In reset position, the moving contact buttons should set on the turned-in prongs of the front molded block evenly. Upper and lower contact buttons should be reasonably parallel.

If any difficulties are encountered in these mechanical settings, refer to the section titled SERVICING.

#### ELECTRICAL TESTS

Since all drawout relays in service operate in their cases, it is recommended that they be tested in their cases or an equivalent steel case. In this way any magnetic effects of the enclosure will be accurately duplicated during testing. A relay may be tested without removing it from the panel by using a 12XLA13A test plug. This plug makes connections only with the relay and does not disturb any shorting bars in the case. Of course, the 12XLA12A test plug may also be used. Although this test plug allows greater testing flexibility, it also requires CT shorting jumpers and the exercise of greater care since connections are made to both the relay and the external circuitry.

All alternating current operated devices are affected by frequency. Since non-sinusoidal waveforms can be analyzed as a fundamental frequency plus harmonics of the fundamental frequency, it follows that alternating current devices (relays) will be affected by the applied waveform.

Therefore, in order to properly test alternating current relays it is essential to use a sine wave of current and/or voltage. The purity of the sine wave (i.e. its freedom from harmonics) cannot be expressed as a finite number for any particular relay, however, any relay using tuned circuits, R-L or RC networks, or saturating electromagnets (such as time overcurrent relays) would be essentially affected by non-sinusoidal wave forms.

Similarly, relays requiring d-c control power should be tested using d-c and not full wave rectified power. Unless the rectified supply is well filtered, many relays will not operate properly due to the dips in the rectified power. Zener diodes, for example, can turn off during these dips. As a general rule the d-c source should not contain more than 5 percent ripple.

It is recommended that the relay be tested using the 12XLA12A test plug connected as shown in Fig. 7. These tests ensure correct relay operation and correct grounding of relay and rotor.

- 1) Remove connection plug.
- 2) Place time-delay link on "In" position.
- 3) Make connections on test plug before inserting into relay. Apply rated voltage to studs 9-10.
- 4) Insert test plug into relay.
- 5) Close the test switch. A unit should pick up instantaneously. After 2  $\pm$ 0.5 seconds, AX and AY should seal in, target should appear, trip contacts close, and A unit drops out. Relay is now set. Open test switch.
- 6) Press microswitch and reset target after two or more minutes. AX and AY should drop out, and target should drop. Unit is now reset.
- 7) Remove test plug.
- 8) Place time-delay link on "OUT" position.
- 9) Reinsert test plug.
- 10) Close the test switch. Unit A should pick up causing AX and AY to seal in instantaneously. Unit A drops out as soon as seal-in is complete. Target appears and trip contacts close. Unit AY is now set. Open test switch.
- 11) Press microswitch, then reset target. AX and AY should drop out, and target should drop. Unit is now reset.
- 12) Remove the test plug.
- 13) Set time-delay link for desired operation.
- 14) Reinsert connection plug. If external connections have been made correctly, relay is now ready for operation.

CAUTION - Capacitors storing large charges may endanger testing personnel. Do not handle the relay after electrical testing until C<sub>1</sub> and C<sub>2</sub> capacitors have been discharged (two largest capacitors in back upper left and back middle).

If any difficulty arises in carrying out this procedure, refer to section titled SERVICING.

#### PERIODIC TESTING AND ROUTINE MAINTENANCE

In view of the vital role of protective relays in the operation of a power system it is important that a periodic test program be followed. It is recognized that the interval between periodic checks will vary depending upon environment, type of relay and the user's experience with periodic testing. Until the user has accumulated enough experience to select the test interval best suited to his individual requirements it is suggested that the points listed under INSTALLATION PROCEDURE be checked at an interval of from one to two years.

Check the items described under ACCEPTANCE TESTS - VISUAL INSPECTION AND MECHANICAL INSPECTION. Examine each component for signs of overheating, deterioration or other damage. Check that all connections are tight by observing that the lockwashers are fully collapsed.

#### CONTACTS

Examine the contacts for pits, arc or burn marks, corrosion, and insulating films. For cleaning contacts, a flexible burnishing tool should be used. This consists of a flexible strip of metal with an etched-roughened surface resembling in effect a superfine file. The polishing action is so delicate that no scratches are left, yet it will clean off any corrosion thoroughly and rapidly. Its flexibility insures the cleaning of the actual points of contact. Do not use knives, files, abrasive paper or cloth of any kind to clean relay contacts.

OPERATIONAL CHECKS

For more frequent operational checks when the machine rotor is not accessible, a modification to the connections of Fig. 7 may be made. Grounding inner pin 3 of the 12XLA12A plug through the test switch and 500 ohms resistor allows the tests outlined in INSTALLATION PROCEDURE to be followed. Note that this modification does not ensure proper rotor grounding.

In some applications, an external test-reset switch is connected as shown in Fig. 6. For operational testing when an external test-reset switch is included, follow the procedure outlined below:

Time-delay link on "IN" position

- 1) Turn switch to TEST position for at least three seconds. Relay should operate in  $2 \pm 0.5$  seconds. Alarm should sound and target should be displayed. Relay is now set.
- 2) Turn the switch to RESET position after at least two minutes. Alarm should cease. Target does not drop. Target must be reset mechanically by pressing lower left reset button.

Time-delay link on "OUT" position

- 1) Turn switch to TEST position. Relay should operate instantaneously. Alarm should sound and target should be displayed. Relay is now set.
- 2) Turn the switch to RESET position. Target does not drop. Target must be reset mechanically by pressing lower left reset button.

Note that the tests of this paragraph do not test correct relay or rotor grounding.

ADDITIONAL CHECKS

Of course, whenever the relay is tested, it should be inspected for proper mechanical operation. All connections should be tight and mechanical parts should move freely. Be sure none of the wires are pinched between cradle and case.

SERVICINGMECHANICAL ADJUSTMENTS

All readjustment of contact shape, contact gap, spring tension and lead formation should be done with a certain amount of delicacy and, of course, the proper tools. Contacts are strained gradually so that no creases or permanent bends deform their shapes and render them non-operational. For adjustment purposes, a 12XRT11A1 relay tool kit is recommended.

- 1) Unit A – One normally open contact
  - a) The stationary contact consists of three members. From top to bottom, they are the back stop, the moving contact, and contact rest arm. The moving contact must be formed such that contact gap is 3/32 inch (do not reshape with any additional sudden bends). The backstop is formed such that it is barely engaged when the plunger is in its fully picked up position. Any reshaping of the backstop must occur at the right angle bend next to the mounting screw. With these adjustments, contact wipe is approximately 3/64 inch.
  - b) Lead is formed such that it does not touch molded parts or inhibit motion in any way.
- 2) Unit AX – One normally open contact, two normally closed contacts
  - a) Normally open contact is formed such that contact gap is 0.125 to 0.150 inches.
  - b) Normally closed contacts part within 1/64 inch of each other. Contact gap should be at least 1/16 inch when relay is operated by hand.
  - c) Normally open contact must close before normally closed contacts open. If not, adjust gap screw on normally closed contacts.
- 3) Unit AY
  - a) In reset position, cross member of "T" spring rests evenly on the turned-in prongs of the front molded block. A slight twisting of this member is made to make it horizontal.

- b) Fixed contacts are adjusted so that contact buttons make at the same time with 1/32 inch wipe. Raising armature by hand until contacts just make should leave a 1/64 inch air gap between freeze pin of armature and pole piece.

PICKUP CALIBRATION

It is recommended that external voltage be applied with a 12XLA13A test plug. Voltage must be at rated frequency and accurately metered.

Before inserting test plug into the relay, apply voltage leads to studs 9-10, a 0-to-100 ohms rheostat across studs 3-4, and a continuity indicating lamp across studs 1-2. Time-delay link is placed on "OUT" position. Set resistance to maximum.

Insert test plug; voltage should be set to 79 to 81 percent of rated voltage. Reset relay by depressing the microswitch. The variable resistance is gradually decreased from 100 ohms. Unit A should pick up and set the AY unit (continuity light on) just at the zero ohm point. If pickup is too high (unit A plunger does not pick up when zero is reached), knurled armature is turned counterclockwise as viewed from the top. Similarly, if pickup is too low (unit A plunger picks up before zero is reached) knurled armature is turned clockwise as viewed from the top. After the setting is made, increase resistance to maximum, and reset the unit. Repeat decreasing resistance gradually to see if unit picks up without further adjustment. Correct calibration occurs when gradual resistance reduction to zero will cause the relay to operate for five successive tries without readjustment.

As a final check, 550 ohms is suddenly applied across studs 3-4. Unit A should not pick up.

Since the last edition, Figure 8 has been changed.

GROUND FAULT RESISTANCE SENSITIVITY  
100% RATED VOLTAGE

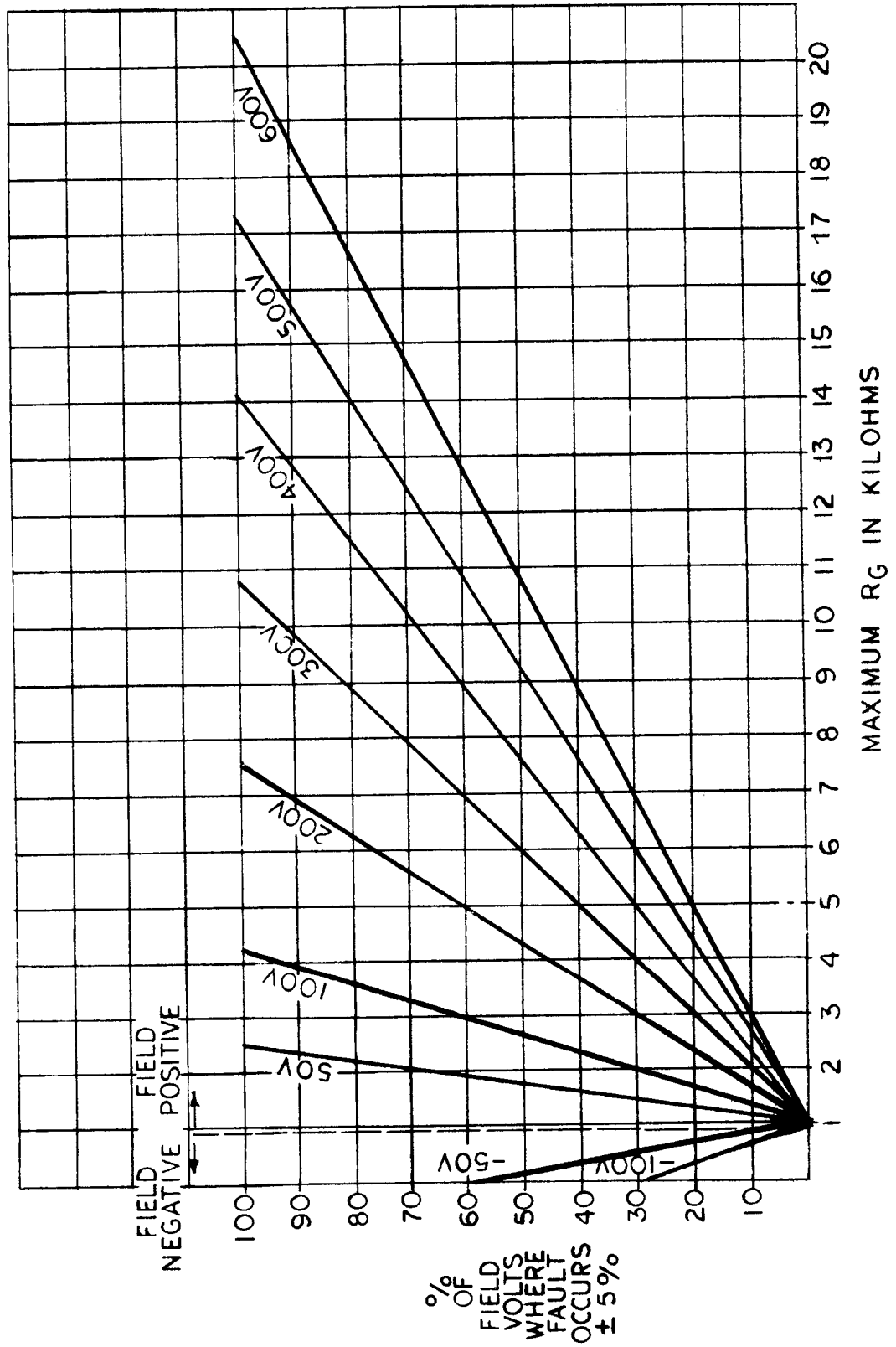

Fig. 1 (0269A3004-0) Ground Fault Resistance Sensitivity 100 Percent Rated Voltage

GROUND FAULT RESISTANCE SENSITIVITY  
80% RATED VOLTAGE

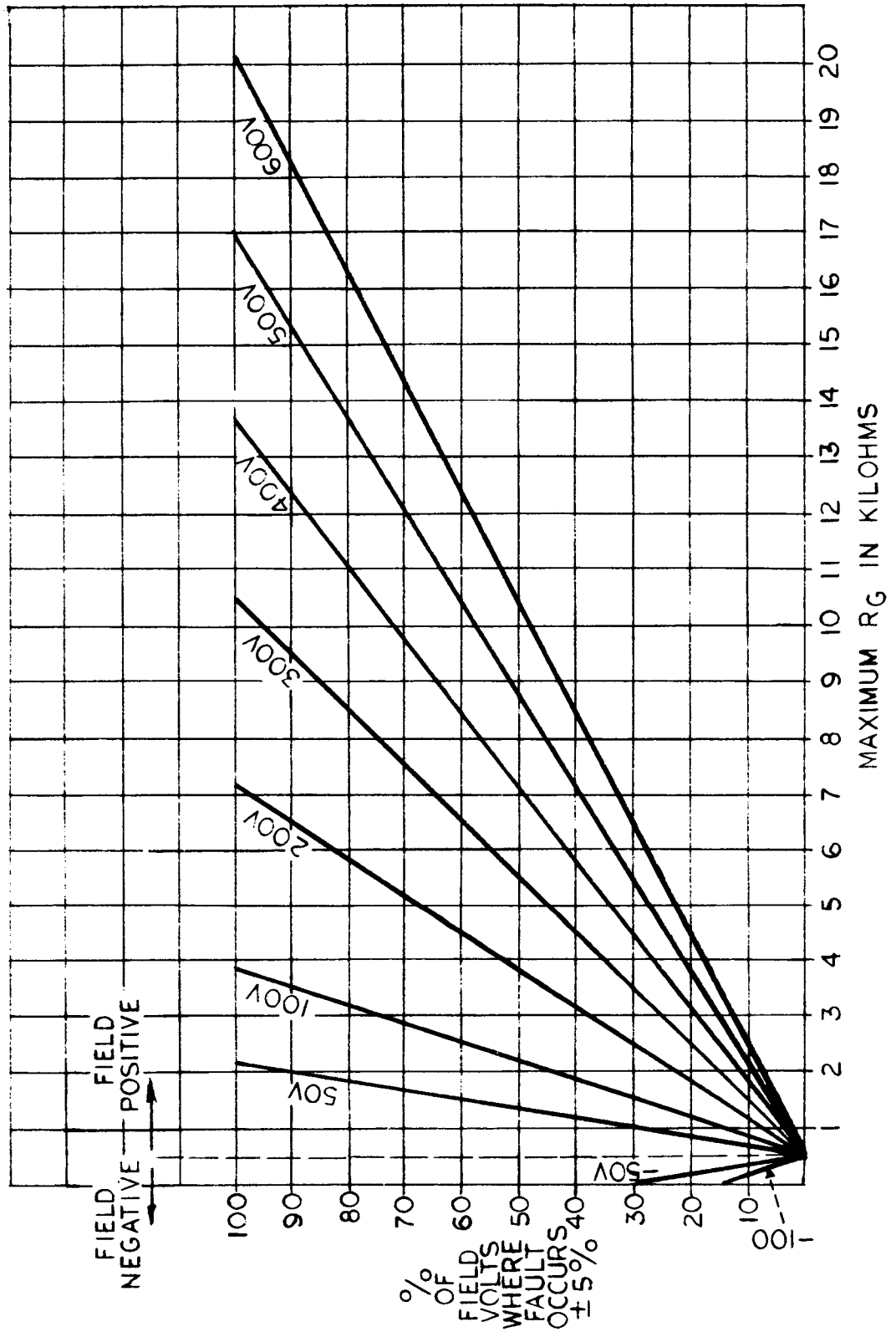
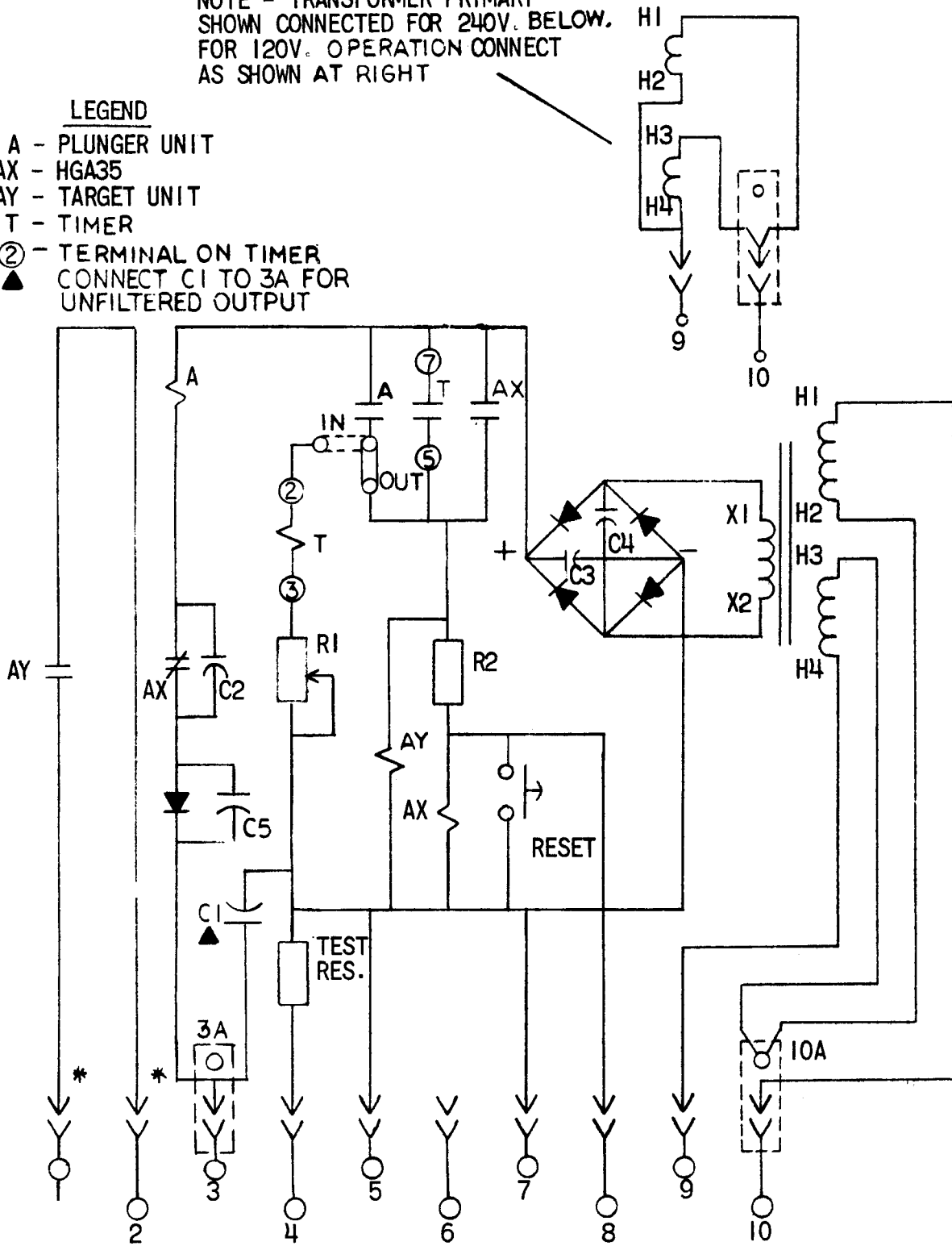

Fig. 2 (0269A3005-0) Ground Fault Resistance Sensitivity 80 Percent Rated Voltage

NOTE - TRANSFORMER PRIMARY SHOWN CONNECTED FOR 240V. BELOW. FOR 120V. OPERATION CONNECT AS SHOWN AT RIGHT

- LEGEND**
- A - PLUNGER UNIT
  - AX - HGA35
  - AY - TARGET UNIT
  - T - TIMER
  - ② - TERMINAL ON TIMER
  - ▲ - CONNECT C1 TO 3A FOR UNFILTERED OUTPUT



\* SHORT FINGERS

Fig. 3 (0246A6971-4) Internal Connections (Front View)

SIMPLIFIED CONNECTION DIAGRAM

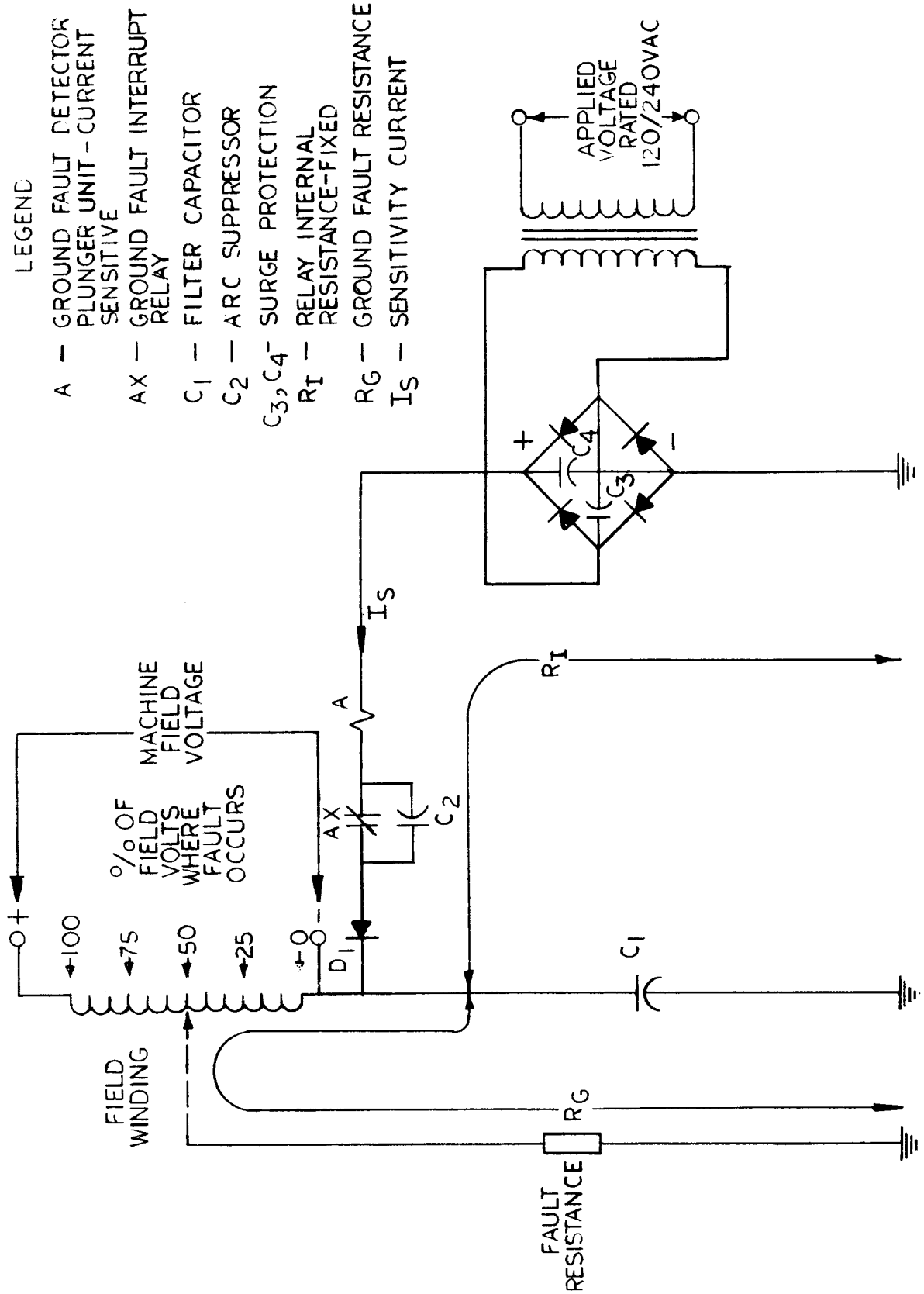

LEGEND

- A — GROUND FAULT DETECTOR PLUNGER UNIT - CURRENT SENSITIVE
- AX — GROUND FAULT INTERRUPT RELAY
- C1 — FILTER CAPACITOR
- C2 — ARC SUPPRESSOR
- C3, C4 — SURGE PROTECTION
- RI — RELAY INTERNAL RESISTANCE - FIXED
- RG — GROUND FAULT RESISTANCE
- IS — SENSITIVITY CURRENT

Fig. 4 (0269A3006-0) Simplified Connection Diagram

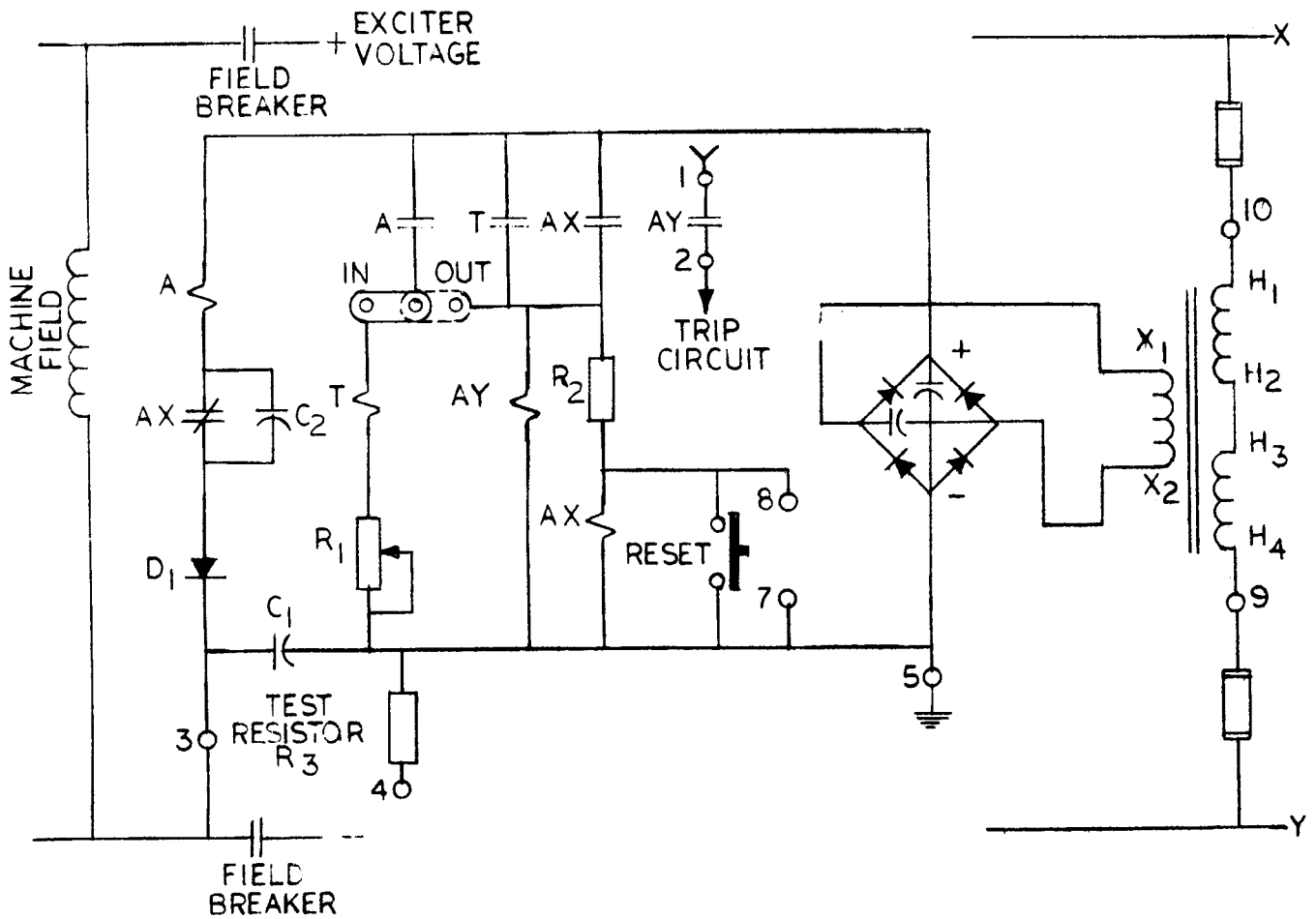

**NOTE:**

- 1 - STUD NUMBERS REFER TO PJG12B RELAY.
- 2 - TRANSFORMER PRIMARY SHOWN CONNECTED FOR 240VAC. FOR 120VAC, PRIMARIES ARE CONNECTED AS FOLLOWS:

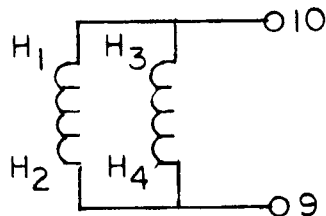
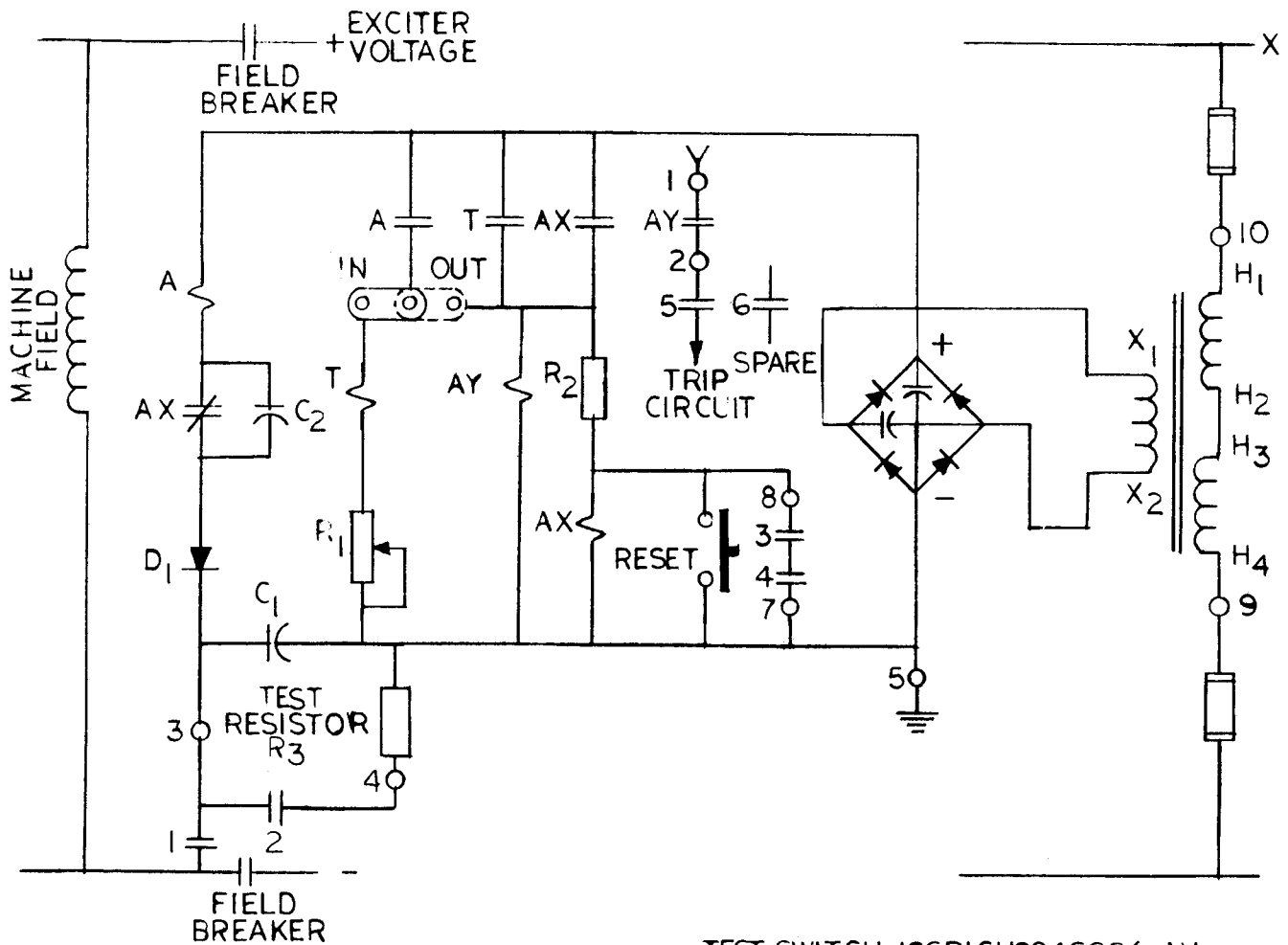

Fig. 5 (0269A3007-0) External Connections for PjG12B Relay Without External Test Switch



TEST SWITCH 1G5BICH984SSS(-)V  
 \*X" DENOTES CONTACT CLOSED

**NOTE:**

- 1 - STUD NUMBERS REFER TO PJG12B RELAY.
- 2 - TRANSFORMER PRIMARY SHOWN CONNECTED FOR 240VAC. FOR 120VAC PRIMARIES ARE CONNECTED AS FOLLOWS:

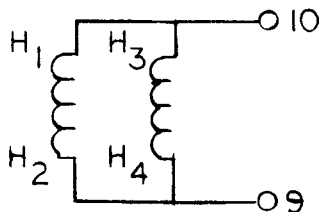

- 3 - THIS TEST CHECKS CORRECT RELAY OPERATION BUT NOT THE FACT THAT THE ROTOR IS PROPERLY GROUNDED.

CONTACTS HANDLE END	(FV) POSITIONS		
	NOR	RESET	TEST
1    2	X		
3    4		X	X
5    6	X		
		X	X

Fig. 6 (0269A3008-0) External Connections for PJG12B Relay with External Test Switch

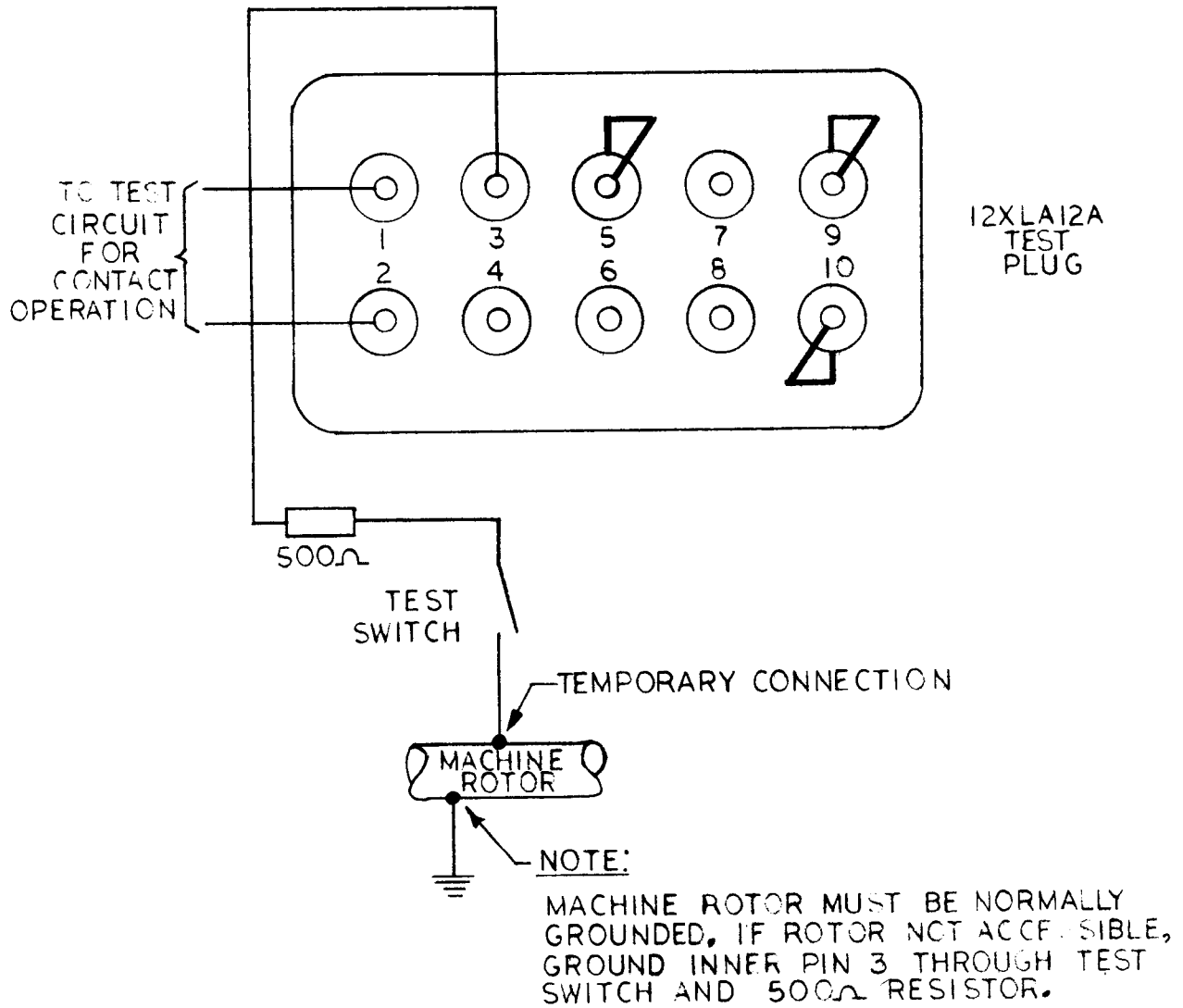

Fig. 7 (0269A3009-0) Test Plug Connections for Relay Operation and Suitable Grounding

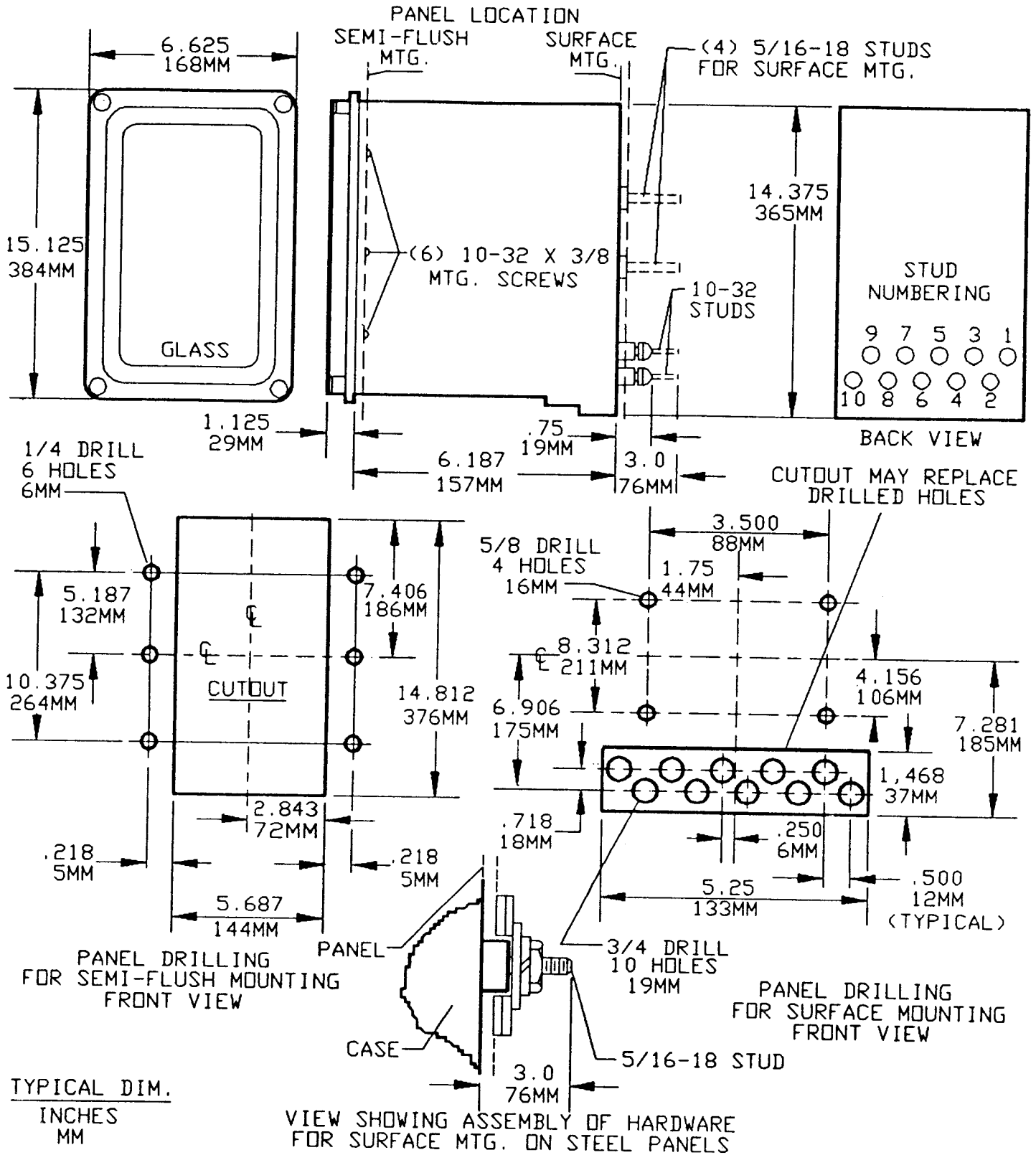

Fig.8 (6209273 [5]) Outline and Panel Drilling



***Protection and Control  
Business Department***

---

(8/93) (200)

General Electric Company  
205 Great Valley Parkway  
Malvern, Pennsylvania 19355-1337