



INSTRUCTIONS

GEK-45346B

AUTOMATIC RECLOSING RELAY

TYPE NSR21G

GENERAL  ELECTRIC

CONTENTS

	<u>Page</u>
DESCRIPTION.	3
APPLICATION.	3
GENERAL CONSIDERATIONS.	3
RATINGS.	4
CHARACTERISTICS.	4
OPERATING PRINCIPLES.	5
BURDENS.	5
CONSTRUCTION	5
RECEIVING, HANDLING AND STORAGE.	6
ACCEPTANCE TESTS	6
VISUAL INSPECTION	6
MECHANICAL INSPECTION	6
ELECTRICAL TESTS.	6
RECLOSING UNIT: TIMING CHECK	7
RECLOSING-DELAY UNIT: TIMING CHECK	7
INSTALLATION PROCEDURE	7
INTRODUCTION.	7
TEST PLUGS.	8
ELECTRICAL TESTS AND SETTINGS	8
SERVICING.	8
RECLOSING UNIT: TIME ADJUSTMENT.	8
RECLOSING-DELAY UNIT: TIME ADJUSTMENT.	8
RENEWAL PARTS.	8

RECLOSING RELAYTYPE NSR21GDESCRIPTION

The type NSR21G relay is a self-resetting, "single shot" reclosing relay intended to initiate the reclosure of a power circuit breaker that has been tripped by protective relays. It includes an adjustable time delay feature which may be used to delay the actual reclosure of the breaker for a short period of time after the decision to reclose has been made. The relay will operate to initiate a reclosure, following tripping of the breaker, only if a predetermined time has elapsed since the previous successful reclosure.

The basic elements of the type NSR21G relay, which is designed for operation from a DC voltage source, are a timing capacitor, a high resistance rheostat, a telephone-type relay having two electrically separate coils, a static timer with adjustable time cycle, and a zener-type voltage regulator to maintain a constant voltage across the timing capacitor and its adjusting rheostat. A link is provided to permit selection of the desired DC voltage rating as described in the section on RATINGS.

The type NSR21G relay is mounted in the size S1 drawout case. The outline and panel drilling dimensions of which are shown in Fig. 6. The internal connections are shown in Fig. 5.

APPLICATION

The type NSR21G reclosing relay is usually applied with transmission line circuit breakers where a single reclosure with a slight time delay is desired, and where if this single reclosure attempt is unsuccessful, it is desired to lock out the breaker. The usual application of this relay is with transmission line relaying schemes, either electromechanical or static, which include a reclosure initiation function (RI) to initiate the reclose sequence when these protective relays operate. The external connections for such an application are shown in Fig. 2. Note that for this application the green color-coded lead must be connected to terminal 8.

On some transmission line applications it is desirable to block reclosing in the event that the breaker is tripped during an out-of-step condition. The diagram in Fig. 2 shows the use of contacts of an auxiliary unit OB for this purpose. This OB unit is included in the out-of-step detecting relay identified as device 68.

On applications where a single reclosure is desired when the breaker is tripped by any line protective relays, reclosing can be initiated by the "b" switch of the breaker (52/b). The application of the NSR21G relay in such a scheme is covered by the external connection diagram of Fig. 3. Note that for this application the green color-coded lead must be connected to terminal 3.

With the scheme as shown in Fig. 3 the short delay in the reclosure will be present regardless of which protective relays tripped the breaker. A possible alternate arrangement is to use the spare 79/A unit contact (between studs 9-10) in conjunction with the RI contact to bypass the 79/TV contact as shown in Fig. 4. This will provide high-speed reclosing when the breaker is tripped by high-speed pilot relaying, and delayed reclosing following a time-delay trip.

GENERAL CONSIDERATIONS

The following general points must be considered when applying automatic reclosing relays.

1. Interrupting Rating of Power Circuit Breaker - The derating factor applying to the interrupting rating of the power circuit breaker should be checked prior to the application of a reclosing relay.
2. Closing Control Circuits - When automatic reclosing is used, it is essential that the closing

These instructions do not purport to cover all details or variations in equipment nor to provide for every possible contingency to be met in connection with installation, operation or maintenance. Should further information be desired or should particular problems arise which are not covered sufficiently for the purchaser's purposes, the matter should be referred to the General Electric Company.

To the extent required the products described herein meet applicable ANSI, IEEE and NEMA standards; but no such assurance is given with respect to local codes and ordinances because they vary greatly.

circuits with solenoid mechanisms ensure complete closure of the breaker even though the auxiliary switch on the breaker mechanism opens before the closure is complete.

3. Latch-checking switches - In order to ensure successful operation of a breaker reclosed by a type NSR relay, it is necessary that the breaker mechanism be equipped with a latch-checking switch if the mechanism is trip-free. This switch ensures that the mechanism latch is properly set for reclosure before the closing circuit is completed. Latch-checking switches are not required for non-trip-free mechanisms.
4. Control Switches - A control switch (typically Model 16SB189) should be provided with automatic reclosing schemes using the type NSR reclosing relays. This switch includes contacts to prevent the breaker from being automatically reclosed after it has been tripped by the control switch. The breaker must be reclosed by means of the switch before the automatic reclosing feature will be restored.
5. Undervoltage Devices - Where undervoltage devices are involved on the circuit by the breaker it is usually necessary to coordinate the reclosing time and the trip time of the undervoltage to ensure that the desired results are obtained. Where the UVD is involved in a throwover scheme, the initial reclosure usually should be faster. Where motor control is involved, it may or may not be desirable for the initial reclosure to be faster. Each application should be checked to determine the required coordination.
6. Associated Protective Relays - If high-speed reclosing is to be successful, the protective relays that tripped the breaker obviously must reopen their contacts before the breaker recloses. Some of the superseded types of induction time-overcurrent relays are not suitable for use with high-speed reclosing. If distance relays are supplied from line-side potential, their contacts should be supervised by contacts of instantaneous fault detectors to ensure that the trip circuit is open before the breaker recloses.

RATINGS

Type NSR21G relays are rated 48/125/250 volts DC. Voltage selecting links are included to permit the selection of the desired control voltage. The relay contacts will close and carry momentarily 30 amperes DC at control voltages of 250 volts or less. These contacts will carry three amperes continuously and have an interruption rating as given in Table A.

TABLE A

CONTACT INTERRUPTING ABILITY

Volts	Interrupting Cap. (Amps) Inductive**
48 DC	1.0
125 DC	0.5
250 DC	0.25
115 - 60 Cyc.	0.75
230 - 60 Cyc.	0.5

**Inductance of average trip coil. The non-inductive interrupting ratings for repetitive protective duty are approximately two-and-a-half times ratings shown in the table.

CHARACTERISTICS

The NSR21G type relay is designed to provide a time delay initiation of a breaker reclosure. The time delay is adjustable between 0.05 and 3.0 seconds by means of a RC unijunction timing circuit. After the relay has operated, the relay will not operate again if the breaker does not remain closed until the reset time has elapsed. The reset time is adjustable from three to 20 seconds and is explained fully in the OPERATING PRINCIPLES.

OPERATING PRINCIPLES

The operation of these relays is best understood by referring to the typical external connection diagram in Fig. 3. With the circuit breaker closed, the auxiliary switch 52/b will be open and the timing capacitor (79/CAP) will be charged through the closed contacts of 86 and 79CO, and the charging rheostat (79/RHEO). The capacitor voltage at full charge is limited to 30 volts by the zener regulator connected across the capacitor and rheostat. The regulator assures that the voltage across the capacitor-rheostat combination, and hence the reset time, will be independent of variations in the supply voltage.

When the breaker is tripped closure of the 52/b contact will discharge the capacitor through the operating coil of the telephone-type unit (79/OC) causing that unit to pick up and seal in by means of its holding coil (79/HC), and energize the included static timer (79/TU). Subsequent closure of the timer contacts between terminals One and Two will energize the breaker closing circuit. Another 79 contact discharges the capacitor through the 47 ohm discharge resistor. This ensures that the timing capacitor will be fully discharged so that full reset time will be realized after each operation.

When the breaker recloses, the 52/b switch will open deenergizing the holding coil and causing the relay to reset. The timing capacitor will then commence to recharge. The reset time of the relay is defined as the time required for the capacitor to recharge to the point where its stored energy will be sufficient to pick up the telephone-type relay if the 52/b contact should again discharge the capacitor through 79/OC. This reset time is adjustable over a range of three to 20 seconds (or as defined on the nameplate) by means of the charging rheostat.

If the breaker remains closed for a time longer than the reset time as set by the rheostat, the relay will be ready to initiate a reclosure if the breaker is again tripped. However, if a subsequent opening of the breaker occurs in a time shorter than the reset time of the relay, the stored energy in the capacitor will not be sufficient to pick up the telephone-type relay and the NSR relay will be locked out.

On typical applications with transmission line circuit breakers, high-speed reclosing is initiated by a contact of a reclosure initiating unit (RI) which in turn is operated by the high-speed primary pilot relaying. Operation of the NSR relay in such a scheme, as represented by Fig. 2, is similar to that described above except that it is now the closure of the RI contact that discharges the capacitor through the operating coil (79/OC) to pick up the telephone-type relay. The RI contact also provides an interim seal-in to 79/HC via diode D1 until the breaker auxiliary switch (52/b) closes. As previously noted, a 79 contact discharges the timing capacitor so that full reset time will be realized after each operation. In addition the 52/b contact provides a second discharge path through diode D3 to ensure discharge of the timing capacitor following a manual trip or a trip by backup relaying which does not operate the RI unit.

BURDENS

The relay watts at rated voltage is given in Table B.

TABLE B

Volts	Max. Relay Watts
48	2.5
125	7.5
250	15.5

CONSTRUCTION

The NSR21G relays are assembled in a single-ended (S1) draw-out case. Figs. 1A and 1B show the relay removed from its draw-out case with all major components identified.

The case is suitable for either surface or semi-flush panel mounting and an assortment of hardware is provided for either mounting. The cover attaches to the case and also carries the reset mechanism when one is required. Each cover screw has provision for a sealing wire.

The case has studs or screw connections at the bottom only for the external connections. The electrical connections between the relay units and the case studs are made through spring-backed contact fingers mounted in stationary molded inner and outer blocks between which nests a removable connecting plug which completes the circuits. The outer block, attached to the case, has the studs or external connections, and the inner block has the terminals for the internal connections.

The relay mechanism is mounted in a steel framework called the cradle and is a complete unit with all leads being terminated at the inner block. This cradle is held firmly in the case with a latch at the top and the bottom and by a guide pin at the back of the case. The case and cradle are so constructed that the relay cannot be inserted in the case upside down. The connecting plug, besides making the electrical connections between the respective blocks of the cradle and case, also locks the latch in place. The cover, which is fastened to the case by thumbscrews, holds the connecting plug in place.

To draw out the relay unit the cover is first removed and the plug drawn out. The latches are then released, and the relay unit can be easily drawn out. To replace the relay unit, the reverse order is followed.

A separate testing plug can be inserted in place of the connecting plug to test the relay in place on the panel either from its own source of current and voltage, or from other sources. Or, the relay unit can be drawn out and replaced by another which has been tested in the laboratory.

The cover is provided with a mechanical interlock which prevents replacing the cover unless the connecting plug is in place.

RECEIVING, HANDLING AND STORAGE

These relays, when not included as a part of a control panel, will be shipped in cartons designed to protect them against damage. Immediately upon receipt of a relay, examine it for any damage sustained in transit. If injury or damage resulting from rough handling is evident, file a damage claim at once with the transportation company and promptly notify the nearest General Electric Apparatus Sales Office.

Reasonable care should be exercised in unpacking the relay in order that none of the parts are injured or the adjustments disturbed.

If the relays are not to be installed immediately, they should be stored in their original cartons in a place that is free from moisture, dust and metallic chips. Foreign matter collected on the outside of the case may find its way inside when the cover is removed and cause trouble in the operation of the relay.

ACCEPTANCE TESTS

Immediately upon receipt of the relay, an inspection and acceptance test should be made to insure that no damage has been sustained in shipment and that the relay calibrations have not been disturbed. If the examination or test indicates that readjustment is necessary, refer to the section on SERVICING.

VISUAL INSPECTION

Check the nameplate stamping to insure that the model number and rating of the relay agree with the requisition.

Remove the relay from its case and check that there are no broken or cracked molded parts or other signs of physical damage, and that all the screws are tight.

MECHANICAL INSPECTION

The relay has been adjusted at the factory but if a check shows that the adjustments have been disturbed, the following adjustments may be made to restore the desired operation.

With the telephone-type relays de-energized, each normally open contact should have a gap of 0.010" to 0.015". Observe the wipe on each normally closed contact by deflecting the stationary contact member towards the frame. Wipe should be approximately 0.005". The contact in series with the holding coil must make slightly ahead of the other contacts.

ELECTRICAL TESTS

Since all drawout relays in service operate in their cases, it is recommended that they be tested in

their cases or an equivalent steel case. In this way any magnetic effects of the enclosure will be accurately duplicated during testing. A relay may be tested without removing it from the panel by using a 12XLA13A test plug. This plug makes connections only with the relay and does not disturb any shorting bars in the case. Of course, the 12XLA12A test plug may also be used. Although this test plug allows greater testing flexibility, it also requires CT shorting jumpers and the exercise of greater care since connections are made to both the relay and the external circuitry.

* RECLOSING UNIT: TIMING CHECK

1. Set the NSR VOLT SELECT link to the appropriate battery voltage; similarly adjust the TU VOLT SELECT link.
2. Assemble test setup as shown in Fig. 7.
3. The reset control has been set at the factory between 13 and 16 seconds.
4. Move the switch S1 to DISCHARGE position.
5. Close S2; this charges the capacitor to its normal initial conditions.
6. Open S2; reset timer.
7. Move S1 to the OPEN position.
8. Close S2; then at ten seconds, as shown on timer, move S1 to TEST position.
9. The A telephone relay should not operate.
10. Repeat steps 4, 5, 6, 7.
11. Close S2; then, after 16 seconds as shown on timer, move S1 to test position.
12. The A telephone relay should pick up.
13. This concludes the acceptance tests for the reset circuit. Proceed to the next section for timer unit (TU) tests.

* RECLOSING-DELAY UNIT: TIMING CHECK

1. Set the NSR VOLT SELECT link to the appropriate battery voltage; similarly adjust the TU VOLT SELECT link.
2. Assemble the test setup as shown in Fig. 8.
3. The timer-unit adjustment has been set at the factory at the fifth time setting mark. This time can be read on the nameplate.
4. Push the A telephone relay closed to time the interval.
5. The timer should indicate a time reasonably close to the labeled time. Ensure that fine tuning allows this value to be obtained more accurately.
6. This completes the acceptance tests on the timer units.

INSTALLATION PROCEDURE

INTRODUCTION

The relay should be installed in a clean, dry location, free from dust and excessive vibration, and well lighted to facilitate inspection and testing.

The relay should be mounted on a vertical surface. The outline and panel drilling dimensions are shown in Fig. 6.

The internal connection diagrams for the relays are shown in Fig. 5. A typical connections diagram is shown in Fig. 4.

TEST PLUGS

The relay may be tested without removing it from the panel by using a 12XLA13A test plug. This makes connections only with the relay and does not disturb any shorting bars in the case. Of course, the 12XLA12A test plug may also be used. Although this test plug allows greater testing flexibility, it also requires CT shorting jumpers and the exercise of greater care since connections are made to both the relay and the external circuitry. Additional information on the XLA test plugs may be obtained from the nearest General Electric Apparatus Sales Office.

ELECTRICAL TESTS AND SETTINGS

Most operating companies use different procedures for installation tests. The section under ACCEPTANCE TESTS contains all necessary tests which may be performed as part of the installation procedure. Procedures for setting the relay are discussed in the SERVICING section in this book.

SERVICING

RECLOSING UNIT: TIME ADJUSTMENT

As mentioned earlier, the relay should be tested in its case. Also, a good DC source is necessary to achieve accurate adjustments. If these conditions are met, testing will simulate conditions the relay "sees" in service.

The reset time may be adjusted to a chosen setting by the following technique.

1. Increase or decrease the reset-timer adjustment as desired.
2. Use the circuit and steps outlined in the ACCEPTANCE TEST section to determine the reset time.
3. Fine tune the setting if necessary, and repeat Step 2.

RECLOSING-DELAY UNIT: TIME ADJUSTMENT

Use the procedure outlined under ACCEPTANCE TESTS to set the timer unit. Fine tune the setting until the desired time is achieved.

RENEWAL PARTS

It is recommended that sufficient quantities of renewal parts be carried in stock to enable the prompt replacement of any that are worn, broken, or damaged.

When ordering renewal parts, address the nearest Sales Office of the General Electric Company, specify quantity required, name of the part wanted, and the complete model number of the relay for which the part is required.

www.ElectricalPartManuals.com

Figure 1A (Not Available) Three-Quarter Front View of the NSR21G Relay

Figure 1B (Not Available) Rear View of the NSR21G Relay

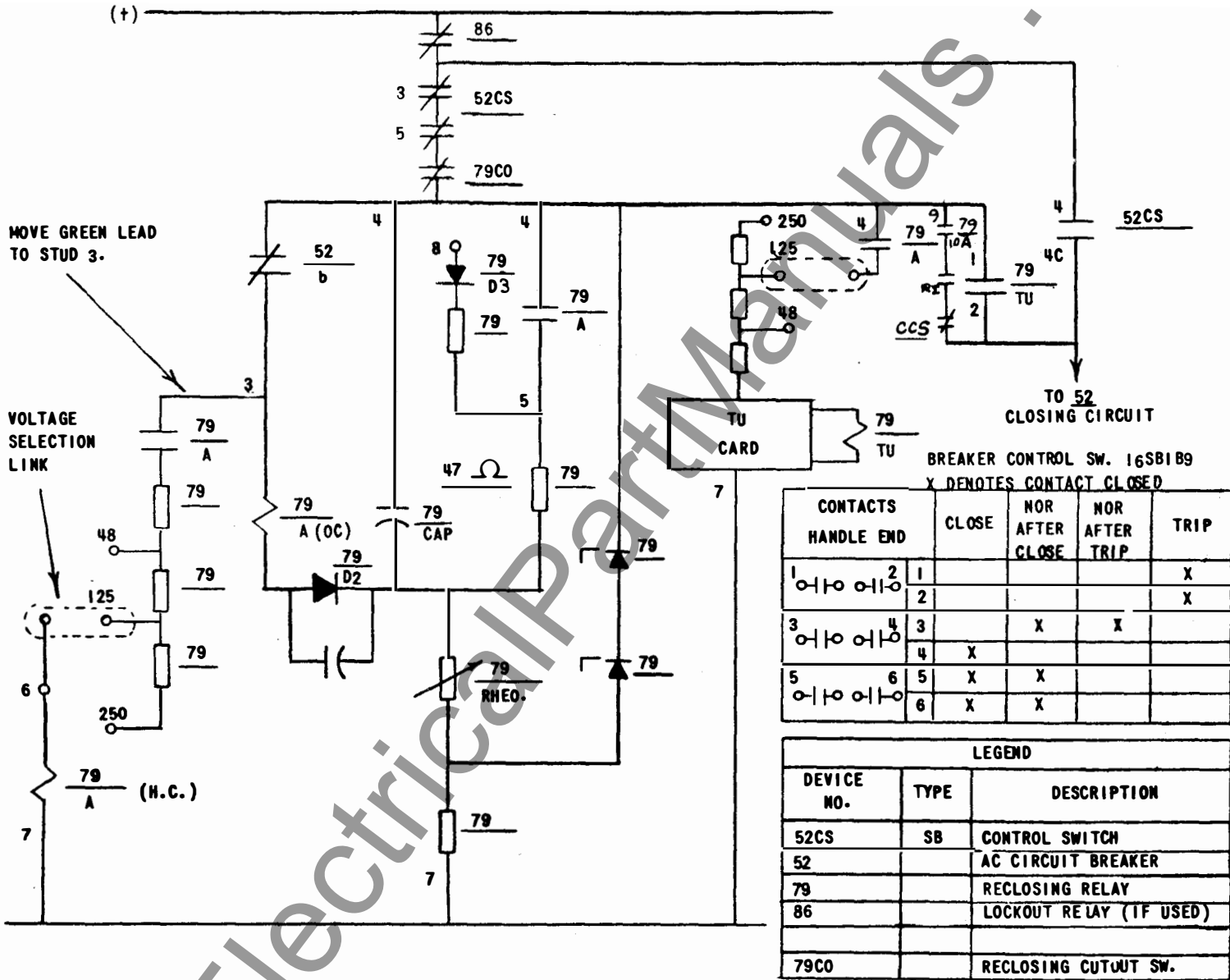

* Figure 4 (0257A5063 [2]) Elementary Diagram for the NSR21G Relay (Reclosure Initiated by 52/b, Time Relay Bypassed by RI)

* Revised since last issue

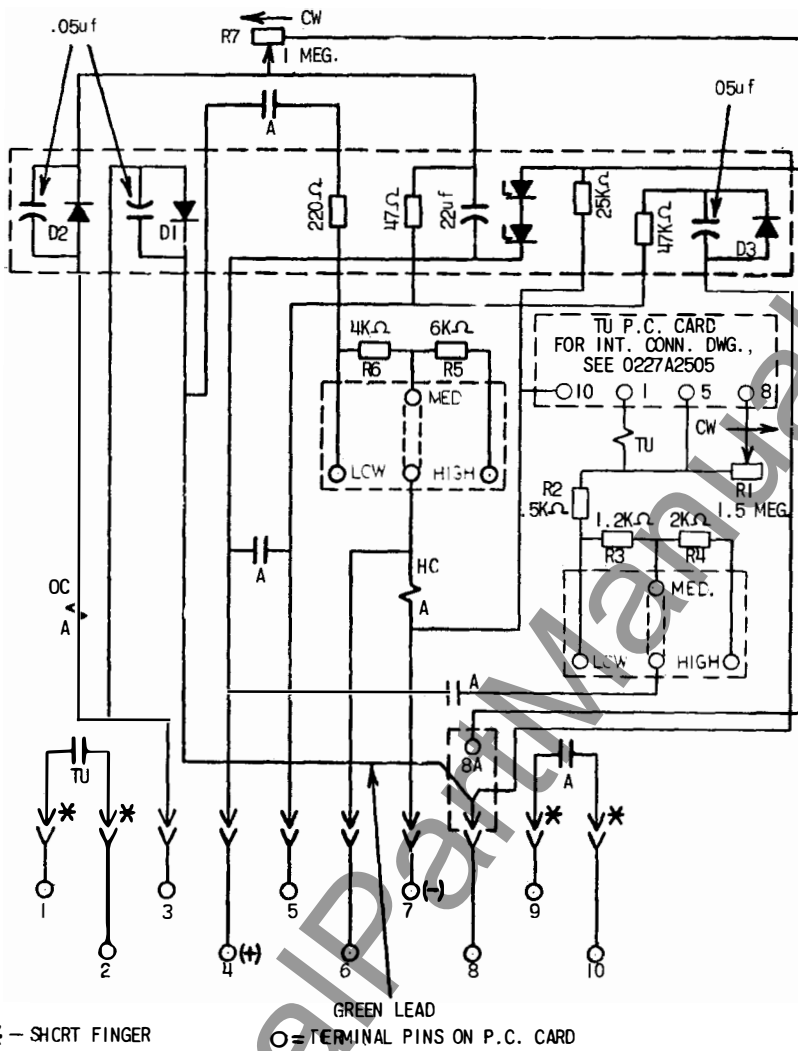

MODEL	FORM		
	1	2	3
12NSR21G(-)A			
VOLTS D.C.	48/125/250		48/110/220
RESISTANCE IN OHMS			
TU COIL	650		
A COIL	2000		
R1	1.5 MEG.		
R2	.5K		
R3	1.2K		
R4	2K		
R5	6K		
R6	4K		
R7	1 MEG.		

* Figure 5 (0257A5098 Sh.1 [1] and Sh.2 [1]) Internal Connections for the NSR21G Relay

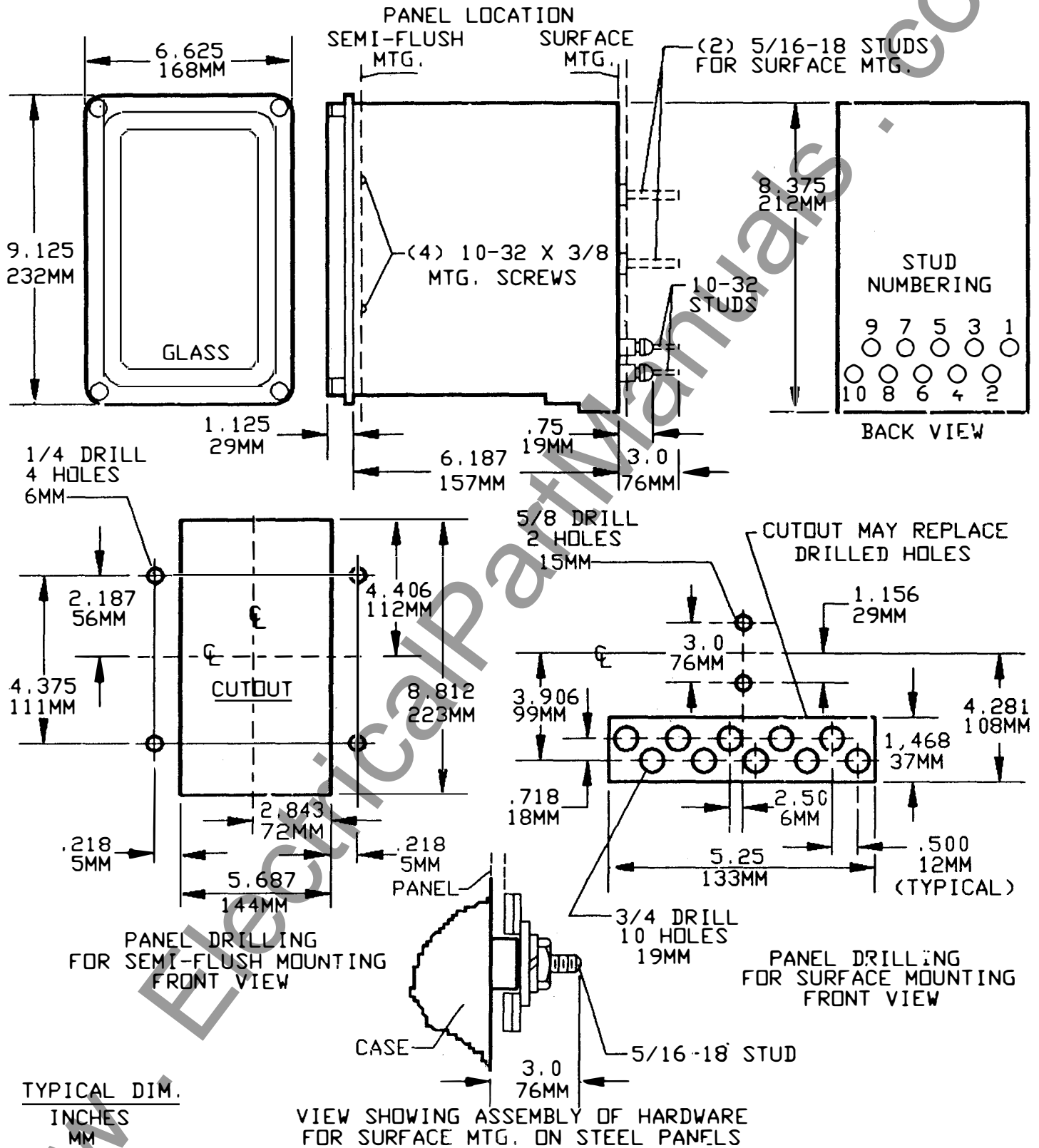

* Figure 6 (K-6209271 [8]) Outline and Panel Drilling Dimensions for the NSRG Relay

S1 - SINGLE POLE,
DOUBLE THROW
CENTER OFF.

S2 - DOUBLE POLE,
SINGLE THROW

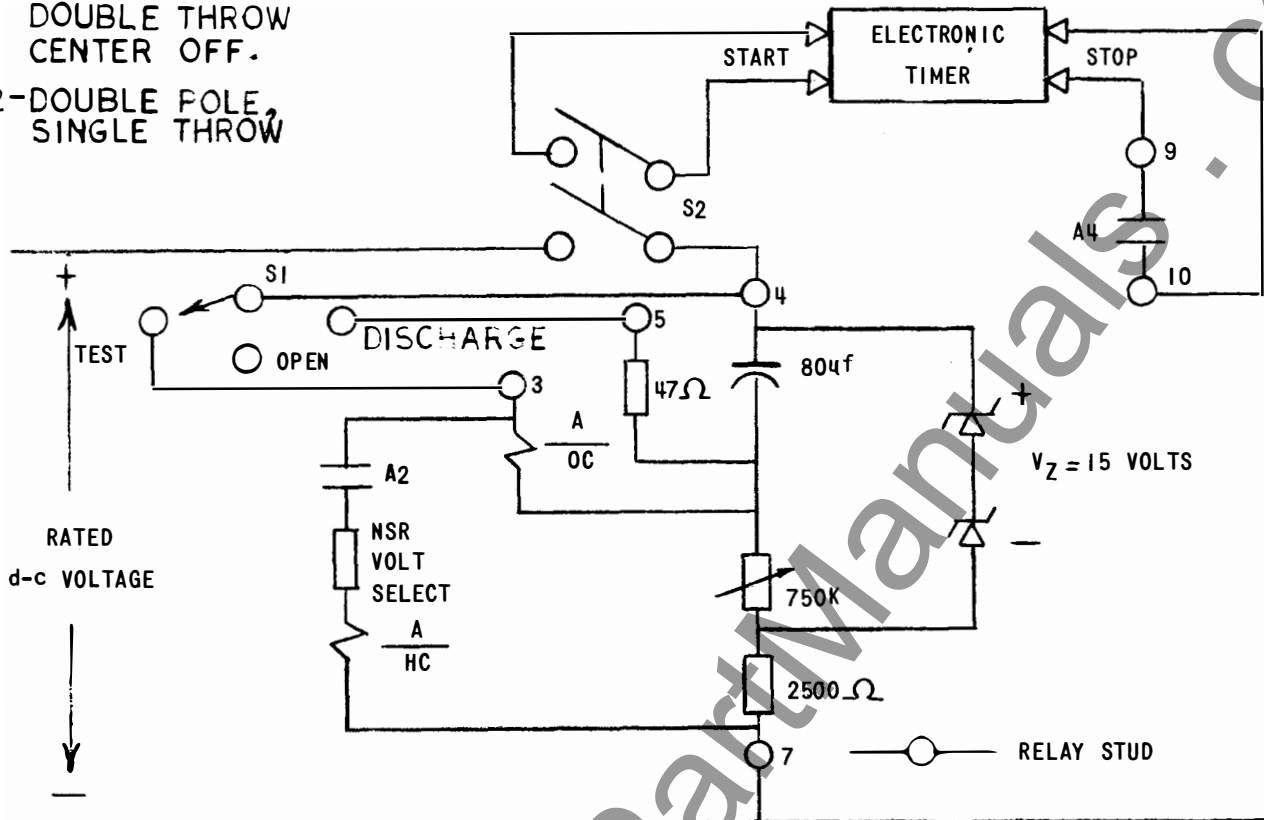

a. SCHEMATIC

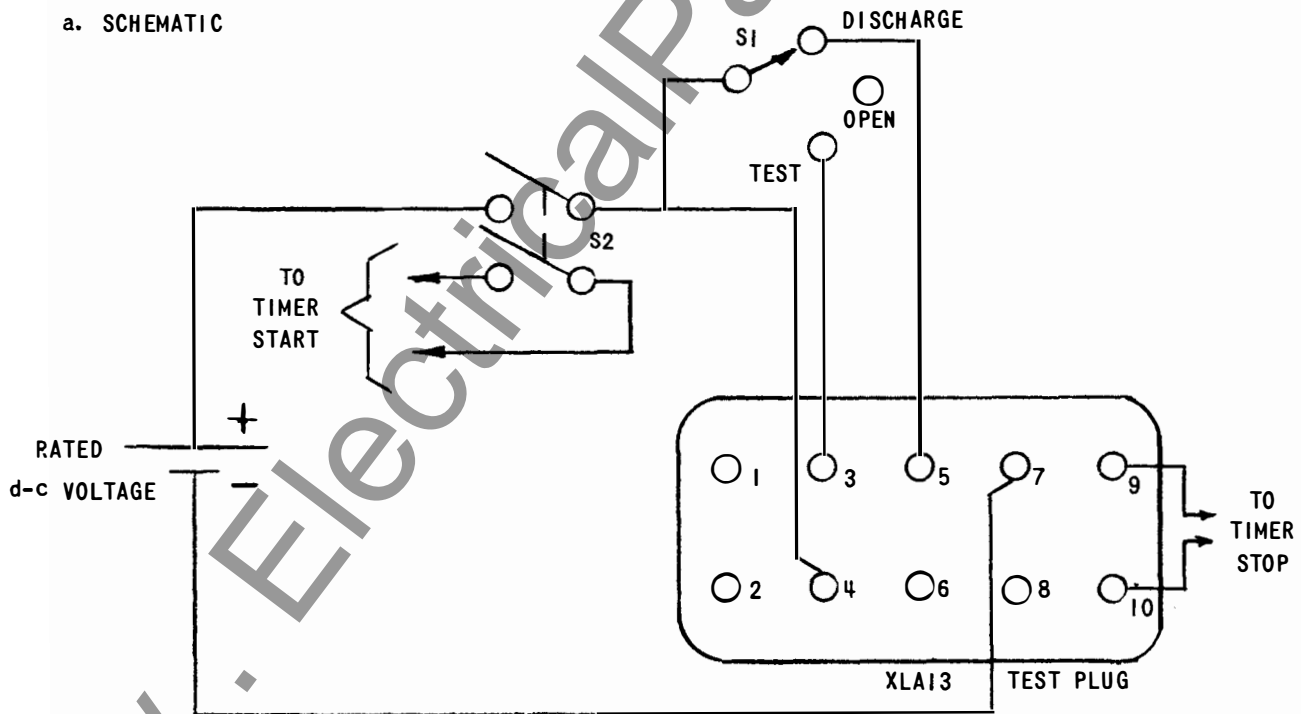

b. TEST PLUG HOOKUP

* Figure 7 (0257A8345-1) Test Connections for Reset Time Calibration and Check

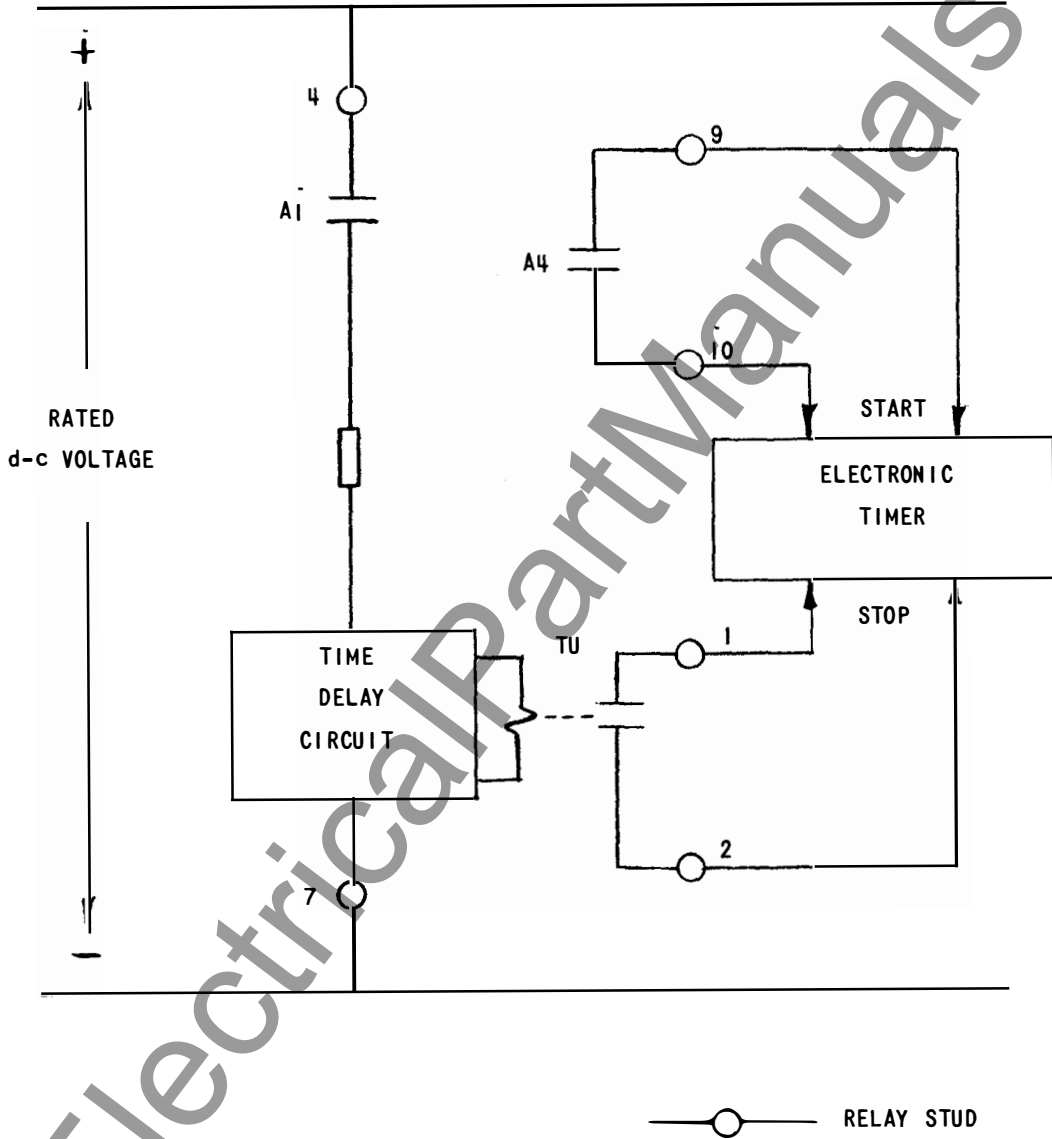

* Figure 8 (0257A8344 [1]) Test Connections for Time Delay Calibration and Check

www.ElectricalPartManuals.com

www.ElectricalPartManuals.com

**GENERAL ELECTRIC COMPANY
POWER SYSTEMS MANAGEMENT BUSINESS DEPT.
MALVERN, PA 19355**

GENERAL  ELECTRIC