



GEK-49777C

INSTRUCTIONS

SFC151D(-)A
SFC153D(-)A

STATIC TIME-OVERCURRENT RELAY

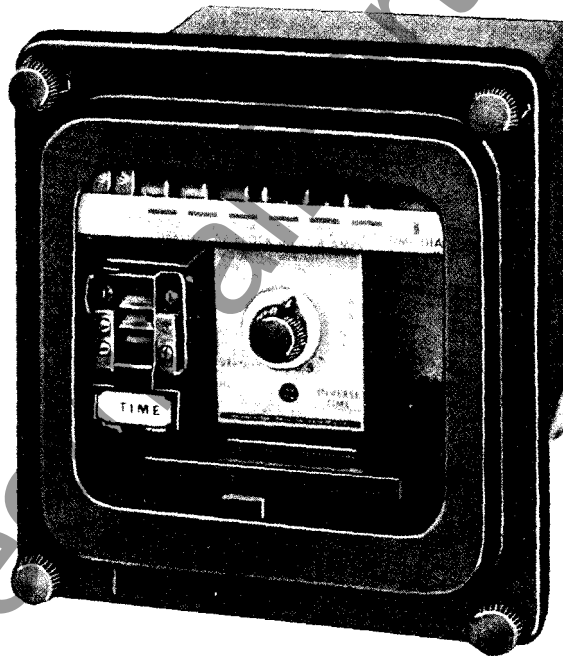

GENERAL ELECTRIC

TABLE OF CONTENTS

Com

	<u>PAGE</u>
DESCRIPTION	3
APPLICATION	3
RATINGS	4
TIME-OVERCURRENT UNIT	4
CONTACT RATINGS	5
AMBIENT TEMPERATURE	6
HIPOT CAPABILITY	6
FREQUENCY	6
DC CONTROL VOLTAGE	6
CHARACTERISTICS	6
OPERATING PRINCIPLES	6
OPERATING CHARACTERISTICS	8
BURDEN	9
CONSTRUCTION	10
GENERAL	10
SIGNAL SOURCE CT2	10
PRINTED CIRCUIT CARD	10
DC SUPPLY COMPONENTS	10
OUTPUT TELEPHONE-TYPE RELAY (TOC)	10
HI-SEISMIC TIME TARGET UNIT	10
CASE	11
RECEIVING, HANDLING, AND STORAGE	11
ACCEPTANCE TESTS	11
VISUAL INSPECTION	12
MECHANICAL INSPECTION	12
ELECTRICAL CHECKS	12
INSTALLATION PROCEDURE	15
INTRODUCTION	15
RELAY SURGE PROTECTION	15
TEST PLUGS	16
SETTINGS	16
ELECTRICAL TESTS	18
PERIODIC CHECKS AND ROUTINE MAINTENANCE	18
SERVICING	18
TIME-OVERCURRENT UNIT	18
CONTACT CLEANING	20
RENEWAL PARTS	20

www.ElectricalPartManuals.com

STATIC TIME-OVERCURRENT RELAY
TYPE SFC

DESCRIPTION

* The Type SCF151D(-)A and SFC153D(-)A relays covered by these instructions are single-phase relays with a time-overcurrent unit. Time-overcurrent relays are used extensively for the protection of utility and industrial distribution systems, and for overload back-up protection at other locations.

* The SFC151D(-)A relay is available with the inverse time-current characteristic shown in Figure 11A. The time-overcurrent unit is presently available with one output contact. The SFC153D(-)A relay has a very inverse time-current characteristic shown in Figure 11B.

The time-overcurrent unit tap setting is adjustable in steps of a fraction of an ampere of the CT secondary current by setting the links in the current tap block. The tap settings presently available are as follows.

TIME-OVERCURRENT TAP RANGE

0.1 - 0.8

TAP BLOCK SETTINGS

From 0.1 to 0.8 in 0.02 ampere steps

The time-overcurrent unit has an 8 to 1 range of overcurrent tap adjustment listed above. The fast reset and insignificant overtravel of the static time unit permits effective use of automatic reclosing in many applications. The SFC151D(-)A requires DC control power. This allows the relay to have a low AC burden.

Each SFC relay is equipped with a hand-reset electromechanical target in series with the time unit contacts which was designed for high seismic capability. The SFC relay is mounted in the compact type VI case shown in Figure 15. Refer to **OPERATING PRINCIPLES** in the section titled **CHARACTERISTICS** for particular information on the relay operation.

APPLICATION

Time-overcurrent relays are used for the protection of feeders, transmission lines, alternating current machines, transformers, and for numerous other applications where accurate measurement of current and timing is necessary.

*Revised since last issue

These instructions do not purport to cover all details or variations in equipment nor provide for every possible contingency to be met in connection with installation, operation or maintenance. Should further information be desired or should particular problems arise which are not covered sufficiently for the purchaser's purposes, the matter should be referred to the General Electric Company.

To the extent required the products described herein meet applicable ANSI, IEEE and NEMA standards; but no such assurance is given with respect to local codes and ordinances because they vary greatly.

The operating time of associated protective devices should be considered in the selection of a time-current characteristic for a particular application to ensure proper coordination with a minimum of circuit isolation.

* The type SFC151D(-)A and SFC153D(-)A relays have the inverse and very inverse time-current characteristic shown in Figures 11A and 11B respectively. These relays are generally applied where the short circuit current magnitude is dependent largely upon the system generating capacity at the time of the fault.

The general practice for grounded distribution system protection is to use a set of three relays for protection against interphase faults and a separate relay for single-phase-to-ground faults. The use of a separate ground relay is advantageous because it can generally be adjusted to provide faster and more sensitive protection for single-phase-to-ground faults than the phase relays can provide. Typical connections for such an application are shown in Figure 1.

The tap setting of the SFC time unit should be chosen so that it will operate for all short circuits in the protected zone, and also provide back-up protection for short circuits in the immediately adjacent system element when possible. The time unit tap setting should be set low enough to insure that the minimum fault current is at least 1.5 times the tap level.

The time-delay adjustment of the time unit should be chosen to assure selectivity with the protection of the adjacent system elements. This adjustment should be made for the condition which yields maximum fault current at the relay location. The time delay is determined by the adjacent relay operating time for this condition, plus a coordinating time allowance which includes the adjacent circuit breaker maximum operating time and a safety factor to accommodate any uncertainties. Since the SFC time unit has insignificant overtravel, the only relay variation that needs consideration in the safety factor is the tolerance on the time curves. A 0.17 second safety factor is generally used if the relay time is determined by selecting a time dial setting from the time curves. This safety factor can be reduced to 0.07 seconds if the time unit is set to the desired time by test.

The static time unit has a maximum reset time of 0.1 second when current is instantaneously reduced to 60% or less of tap setting. This fast reset characteristic permits the use of multi-shot reclosing without a loss of selectivity due to "notching up".

RATINGS

A. TIME-OVERCURRENT UNIT

The time-overcurrent unit continuous and one second AC ratings are shown in Table I.

*

TABLE I

TIME OVERCURRENT UNIT (TAP RANGE)	CONTINUOUS RATING-AMPERES	ONE SECOND RATING
0.1 - 0.8	40 X TAP SETTING	300 X TAP SETTING

*Revised since last issue

The time-overcurrent unit ratings apply for any tap setting within the adjustment range.

The time-overcurrent unit DC power supply input is single rated as stamped on the nameplate. No external dropping resistors are required. The relay will operate on 80% to 110% VDC.

B. CONTACT RATINGS

The TOC telephone-type relay contacts will close and conduct up to 30 amperes momentarily for tripping duty at control voltages of 250 volts DC or less. The current conducting capability must also be limited by the ratings of the target unit operating coil tap setting. Table II gives the target current ratings as well as the resistance and impedance of the operating coil.

TABLE II

	TAP	
	0.2	2.0
D.C. COIL RESISTANCE +10%	7.0	0.13
MIN. OPERATING (AMPERES)	0.15-.20	1.5-2.0
CARRY CONTINUOUSLY (AMPERES)	0.3	3.0
CARRY 30 AMPS FOR (SECONDS)	0.03	4.0
CARRY 10 AMPS FOR (SECONDS)	0.25	30.0
60 HZ IMPEDANCE (OHMS)	52.0	0.53

If the tripping current exceeds 30 amperes, an auxiliary relay should be used whose connections are arranged so that the tripping current is not conducted through the contacts or the target coils of the protective relay.

Table III gives the interrupting ratings for all relay contacts.

TABLE III

AC VOLTS	AMPS	
	INDUCTIVE†	NON-INDUCTIVE
115	0.75	2.0
230	0.5	1.5
DC VOLTS		
48	1.0	3.0
125	0.5	1.5
250	0.25	1.0

† The inductive rating is based on the inductance of an average trip coil.

C. AMBIENT TEMPERATURE

These relays are designed for use in ambient temperatures between -20° and $+55^{\circ}\text{C}$.

D. HIPOT CAPABILITY

The relay will withstand a high-potential test of 1500 volts, 60 Hz rms, applied from all studs (except stud 8) to case and between current and potential circuit studs. Stud No. 8 is surge ground and tied electrically to the relay case and cradle.

E. FREQUENCY

The relay operates on an alternating sine wave current of 50-60 hertz.

F. DC CONTROL VOLTAGE

The relay will operate over a range of 80% to 110% rated DC volts as stamped on the nameplate.

CAUTION

When hipotting this relay, remove one lead of each surge capacitor C1-C4. These capacitors are rated for 600 VDC and the hipot voltage may damage them. Increase the hipot voltage slowly as capacitive effects will raise the voltage above allowable limits and result in breakdown of the relay.

CHARACTERISTICSA. OPERATING PRINCIPLES

- * The SFC151D(-)A and the SFC153D(-)A static time-overcurrent relays are shown in block diagram form in Figure 2. Circuit details for each function are shown in Figures 3 through 9. Figure 10 shows the overall printed circuit card internal connections. Figure 12 shows the overall relay connections.

Referring to the block diagram Figure 2, the protected line CT secondary current (I) flows through the SIGNAL SOURCE CT2. This reduces the secondary current in a ratio of approximately 200:1. The reduced current is made unidirectional and converted proportionally to a voltage e_i by the RECTIFIER AND TAP RESISTOR circuit. The proportionality constant is selected by the setting on the Current Tap Block. The quantity that the relay measures is e_i . The entire circuit reflects a low AC input impedance to the relay input.

The PICKUP LEVEL DETECTOR is used as a permissive device to tell the timing circuitry when to begin timing. The state of the relay, either picked up or not picked up, is transmitted to the timing circuitry by e_o .

The FUNCTION GENERATOR is a wave shaping circuit which shapes e_i to give the desired inverse time characteristic. The shaped wave is e_f .

*Revised since last issue

The TIME DIAL in conjunction with the LINEAR RAMP GENERATOR and LEVEL DETECTOR constitute the timing circuitry. They measure e_0 to determine whether to begin timing or reset. When e_0 switches to its picked up state, the determination of how long to wait before giving a trip signal e_t is accomplished by integrating e_f .

When the timing circuitry "times out", the trip signal e_t closes the TOC telephone-type relay contacts via the OUTPUT CIRCUIT. Trip circuit current energizes the TIME TARGET UNIT to give a target indication.

The description that follows gives more circuit details:

1. The output voltage e_j of the RECTIFIER AND TAP RESISTORS is a unidirectional voltage that is proportional to the relay input current I . The circuit shown in Figure 3 illustrates how the signal level for a given current level can be adjusted in desired steps by paralleling precision resistors in the current tap block.
2. A PICKUP LEVEL DETECTOR circuit monitors the input signal e_j and determines at what level of relay input current I the relay should provide time-delay tripping output. The circuit is shown in Figure 4 where amplifier IC1A functions as a voltage comparator and switches from a positive to a negative saturated state when the reference bias is exceeded. Feedback capacitor $C7$ is selected so that positive switching action occurs when the average bias from e_j just exceeds this reference bias. A potentiometer $R27$ is provided for factory adjustment of the pickup level.
3. The FUNCTION GENERATOR for obtaining the inverse characteristic is shown in Figure 5. In Figure 5, a single operational amplifier is used with a combination of diodes, zener diodes, bias levels, and a feedback network to produce the required piecewise linear gain characteristic for the input voltage level. The characteristic of the FUNCTION GENERATOR (shown in the plot at the right) is of output voltage e_f versus input voltage e_j . The input and output waveforms are shown (at the top) of e_j and e_f versus time.
4. The LINEAR RAMP GENERATOR shown in Figure 6 is a simple integrator circuit that integrates the outputs signal e_f from the FUNCTION GENERATOR. Ten discrete resistors inserted in steps and the time dial vernier covering one of these steps provide ten integrating time constants with vernier control over each step for field adjustment. This adjustment is the Time Dial Setting.
5. A LEVEL DETECTOR consisting of operational amplifier IC1B is used as a voltage level comparator as shown in Figure 7. A negative bias on the inverting input terminal keeps the output clamped at approximately 0.7 volts by means of a feedback diode $D21$. When the output voltage e_r of the linear ramp generator produces a positive bias condition that exceeds the negative bias, the operational amplifier IC1B will switch to a negative saturation level. This switching action establishes that the trip voltage level has been reached.
6. The OUTPUT CIRCUIT and RELAY TOC shown in Figure 8 is used to close the trip circuit contacts. The negative output signal from the LEVEL DETECTOR biases transistor $Q1$ into a saturated "ON" state and energizes the TOC telephone-type relay. A diode placed across the relay coil shunts the

inductive energy and prevents a surge voltage across the transistor when it is switched into a blocking state.

7. The POWER SUPPLY shown in Figure 9 obtains its power from an external DC supply. Filter capacitor C₃ is charged to approximately 45 volts through the dropping resistors and D₆. Regulated ±15 volts and ±5.1 volts for the solid state circuit are obtained from series zener diodes D₇-D₁₀ and resistor R₃ connected across C₃.

Note that the wire wound dropping resistors designated R₂ and R₃ are external to the printed circuit board but contained within the relay. See Figure 12.

B. OPERATING CHARACTERISTICS

1. Pickup and Time Delay

Pickup of the time-overcurrent unit is the minimum input AC current required for the unit to sense a steady state overcurrent condition and close its output contacts after a time-delay operation. This is accurate to ±3% of tap setting at 25°C, ±6% over entire ambient temperature range of -20° to +55°C.

The operating time required for the time-overcurrent unit to close its output contacts when a given multiple of current level above its tap setting is suddenly applied to the relay defines its time-current characteristic. Figure 11A illustrates the time-current characteristic for the inverse time-overcurrent unit. Figure 11B illustrates it for the very-inverse time-overcurrent unit.

Curves are shown for ten integer time dial settings where the time dial vernier adjustment is set at zero. The time dial vernier may be used to set the unit's characteristic between the curves for specific integers.

At an ambient temperature of 25°C, the time-overcurrent unit will meet the published time-current characteristic curve for any integer setting within the tolerances given in Table IV. Percentages are percent of published "time in seconds" operating time value shown in Figure 11.

*

TABLE IV

SFC RELAY	CHARACTERISTIC	TOLERANCE AT MULTIPLES OF RELAY TAP SETTING		
		1.1 - 2	2 - 20	20 - 50
151D(-)A	Inverse	±15%	±7% or 20 ms	±7% or 20 ms
153D(-)A	Very Inverse		whichever greater	whichever greater

*Revised since last issue

Over an ambient temperature range of -20° to +55°C, a unit's operating time will vary from its 25°C ambient operating time within the tolerances given in Table V. Percentages are percent of 25°C ambient operating time for a given relay.

*

TABLE V

SFC RELAY	CHARACTERISTIC	TOLERANCE AT MULTIPLES OF RELAY TAP SETTING		
		1.1 - 2	2 - 20	20 - 50
151D(-)A	Inverse	±8%	±5%	±5%
153D(-)A	Very Inverse			

2. Drop-out and Reset Time

Drop-out of the time-overcurrent unit is the maximum input AC current required for the relay to sense a steady state current level below pickup and open its output contacts. Drop-out to pickup ratio is 98% or more.

Reset time of the overcurrent unit will not exceed 100 milliseconds when current is reduced to 60% or less of tap setting before the unit trips.

C. BURDEN

The AC burdens for the time-overcurrent unit are listed in Table VI. Note that the burden of this relay may be considered entirely resistive.

TABLE VI

RANGE AMPS	FREQUENCY HERTZ	MIN. TAP AMPS	BURDEN IN OHMS AT MULTIPLES OF MIN. TAP			
			1X	3X	10X	20X
0.1/0.8	60	0.1	0.062	0.031	0.020	0.017

The DC burdens for the time overcurrent unit are listed in Table VII.

TABLE VII

RATED DC CONTROL VOLTS	MAXIMUM CURRENT, MA
125	40
220	40
250	40

The impedance of the time target unit is listed in Table II.

*Revised since last issue

CONSTRUCTION

A. GENERAL

- * The SFC151D(-)A and SFC153D(-)A relays are static time-overcurrent relays consisting of a signal source magnetic CT2, a printed circuit card, DC supply components, an output telephone-type relay TOC, and an electromechanical target unit. The overall relay internal connections diagram is found in Figure 12. Figures 13 and 14 show the front and rear views of the relay with its case removed.

B. SIGNAL SOURCE CT2

This magnetic is a toroidal-type CT resembling the shape of a doughnut. The primary and secondary are separated by a surge-grounded electrostatic shield for surge suppression. This CT is mounted on the rear mounting plate by compression between two insulating washers. Refer to Figure 14.

C. PRINTED CIRCUIT CARD

The printed circuit card is mounted horizontally on insulating standoffs projecting from a plate beneath. The settings on the card are made with the blue connectors and the time dial switch located in the front. Calibration potentiometers for both pickup and time are located in the upper front left.

The time dial vernier pot is located in the front center of the relay. It is mounted on a nameplate and backing compound plate. The metal nameplate is thus insulated from cradle. This insures that all associated printed circuit card circuitry is electrically isolated from case and cradle. Refer to Figure 13.

D. DC SUPPLY COMPONENTS

The DC voltage supply is brought in through studs 9-10. It passes through a surge filter consisting of a mutual reactor L1 and capacitance to surge ground by C3 and C4. These components are mounted on a terminal strip in the rear left of the relay. Refer to Figure 14.

Before being applied to "power up" the card, the DC voltage is reduced by dropping resistors R2 and R3. These are mounted horizontally inward from the rear mounting plate.

E. OUTPUT TELEPHONE-TYPE RELAY (TOC)

The TOC unit is mounted horizontally through a void in the rear mounting plate. This places the unit in an accessible position for observation or adjustment. Refer to Figure 14.

F. HI-SEISMIC TIME TARGET UNIT

The target is a small hinged armature unit mounted on the left-hand side of the front of the relay. This unit has its operating coil in series with

*Revised since last issue

the TOC unit contacts. When the target unit operates, it raises its target flag into view. The target flag latches in the exposed position until released by pressing the reset button, in the lower left-hand corner of the relay cover. The target unit has no contacts and is a design which has a high seismic capability.

The operating coil of the target is tapped. The tap plate for the target is on the front of the unit in the lower right-hand corner. The tap plate is engraved showing the tap ratings of the unit and proper tap screw positions for the tap setting.

G. CASE

The components of each relay are mounted on a cradle assembly which can be easily removed from the relay case. The cradle is locked in the case by means of a latch at the bottom. The electrical connections between the case block and cradle block are completed through removable connection plug. (See Figure 16). A separate testing plug can be inserted in place of the connection plug to permit testing the relay in its case. The cover is attached to the front of the case and includes an interlock arm which prevents the cover from being replaced until the connection plug has been inserted.

The case is suitable for either semiflush or surface mounting on panels up to two inches thick. Hardware is available for all panel thicknesses up to two inches, but panel thickness must be specified on the order to insure that the proper hardware will be provided. Outline and panel drilling dimensions are shown in Figure 15.

RECEIVING, HANDLING, AND STORAGE

These relays, when not included as a part of a control panel, will be shipped in cartons designed to protect them against damage. Immediately upon receipt of a relay, examine it for any damage sustained in transit. If injury nor damage resulting from rough handling is evident, file a damage claim at once with the transportation company and promptly notify the nearest General Electric Sales Office.

Reasonable care should be exercised in unpacking the relay in order that none of the parts are injured nor the adjustments disturbed.

If the relays are not to be installed immediately, they should be stored in their original cartons in a place that is free from moisture, dust, and metallic chips. Foreign matter collected on the outside of the case may find its way inside when the cover is removed and cause trouble in the operation of the relay.

ACCEPTANCE TESTS

Immediately upon receipt of the relay an **INSPECTION** and **ACCEPTANCE TEST** should be made to insure that no damage has been sustained in shipment and that the relay calibrations have not been disturbed. If the examination or test indicates that readjustment is necessary, refer to the section on **SERVICING**.

These tests may be performed as part of the installation or acceptance tests at the discretion of the user. Since most operating companies use different

procedures for acceptance and for installation tests, the following section includes all applicable tests that may be performed on these relays.

A. VISUAL INSPECTION

Check the nameplate stamping to insure that the model number and rating of the relay agree. Remove the relay from its case and check that there are no broken or cracked molded parts or other signs of physical damage, and that all the screws are tight.

B. MECHANICAL INSPECTION

1. The armature of the time target unit should move freely when operated by hand.
2. The target in the time target unit must come into view and latch when the armature is operated by hand and should unlatch when the target release lever is operated.
3. The telephone relay unit used in these relays should be checked to have a contact gap of at least 10 mils (0.010 inch) and contact wipe of 5 mils. The contact wipe may be checked by inserting a 5 mil shim between the armature and pole piece and operating the armature by hand. The normally open contacts should make contact with the shim in place when the armature is operated by hand.
4. Make sure that the fingers and shorting bars agree with the internal connections diagram Figure 12.

CAUTION

Every circuit in the draw-out case has an auxiliary brush. It is especially important on current circuits and other circuits with shorting bars that the auxiliary brush be bent high enough to engage the connecting plug or test plug before the main brushes do. This will prevent CT secondary circuits from being opened. See Figure 16.

C. ELECTRICAL CHECKS

1. Draw-out Relays - General

A relay may be tested without removing it from the panel by using a 12XLA13A test plug. This plug makes connections only with the relay and does not disturb any shorting bars in the case. Of course, the 12XLA12A test plug may also be used. Although this test plug allows greater testing flexibility, it also requires CT shorting jumpers and the exercise of greater care since connections are made to both the relay and the external circuitry.

The SFC relay does not require in-case testing. Therefore, it may be advantageous at certain locations to remove the relay from its case for testing.

2. Power Requirements - General

All alternating-current-operated devices are affected by frequency. Since non-sinusoidal waveforms can be analyzed as a fundamental frequency plus harmonics of the fundamental frequency, it follows that alternating-current devices (relays) will be affected by the applied waveform.

Therefore, in order to properly test alternating-current relays, it is essential to use a sine wave of current and/or voltage. The purity of the sine wave (i.e. its freedom from harmonics) cannot be expressed as a finite number for any particular relay, however, any relay using tuned circuits, RL or RC networks, or saturating electromagnets (such as time-overcurrent relays) would be essentially affected by non-sinusoidal waveforms.

Similarly, relays requiring DC control power should be tested using DC and not full wave rectified power. Unless the rectified supply is well filtered, many relays will not operate properly due to the dips in the rectified power. Zener diodes, for example, can turn off during these dips. As a general rule, the DC source should not contain more than 5% ripple.

This relay responds to the input current waveform in a different manner than most AC ammeters. Therefore, if the test source contains high amplitude harmonics the ammeter and relay responses will be different. The relay has been calibrated using a conventional 60 Hz shop source of minimum harmonic content. It should be tested with a similar current source of sinusoidal waveform - essentially free from harmonics.

The ammeter and timers used to establish pickup and time-delay characteristics must be calibrated and have accuracies which are considerably better than the accuracy of the relay. In addition, power sources must remain very stable for these tests, especially during pickup and timing tests near the pickup level.

To minimize the effect of the non-linear impedance of the relay the current source should be an adjustable resistor (loadbox) in series with a 120 volt or greater 50/60 Hz power source.

It should be noted that the degree of test accuracy depends on the power source and instrumentation utilized. Functional tests performed with incorrect power supplies and instruments are useful to insure that the relay is functioning properly and its characteristics are approximately verified. However, recalibration of a relay under these conditions will not produce an accuracy that is any better than the test system and would result in characteristics outside the tolerances as specified.

If examination or tests indicate readjustment is necessary, refer to the section titled **SERVICING**.

3. Time-Overcurrent Unit

a. Pickup Calibration Check

1. Connect the relay as shown in Figure 17. Use a source of 120 volts rms or more at rated frequency with current limited by

resistive load to supply operating current to the relay. Current should be stable to $\pm 1\%$ of set level.

2. Set the time dial at number 1 and the time dial vernier fully CCW (counterclockwise). Set the current tap block for a tap setting of 0.1 ampere for the 0.1/0.8 amp relay.

3. Connect a continuity indicating lamp to studs 1-2. When lamp is lit, relay is picked up.

4. Apply rated DC voltage to the relay before applying AC current. Start with a current below the set tap and use the loadbox to gradually increase the current applied to the relay. Increase current to 5% below tap setting. Relay should NOT pick up in at least one minute. Increase current to 5% above tap setting. Relay should pick up in no more than one-half minute.

This same procedure may be used to check pickup at other tap block settings.

b. Time Calibration Check

1. Connect the relay as for the pickup calibration check except a switch is needed so that current may be suddenly applied to the relay. The timer should be arranged so that application of current to the relay starts the timer and trip circuit contact closure stops the timer. See Figure 17.

2. Set the time dial vernier pot fully CCW (counterclockwise). Set the time dial selector switch (on the printed circuit board) to number 5.

3. Set the current tap block at 0.1 amp for the 0.1/0.8 amp relay.

4. Set the loadbox to deliver five times pickup setting to the relay: 0.5 ampere.

5. Apply rated DC voltage to the relay, then suddenly apply AC current to the relay. The time required for the TOC unit to close its contacts should be as follows:

Inverse	1.39 Sec. ± 0.0695 Sec.
---------	-----------------------------

6. This procedure may be used to check the relay operating time at other multiples of tap setting or other time dial settings. The time-current curve for the time-overcurrent unit is shown in Figure 11 for the SFC151D(-)A and in Figure 11B for the SFC153D(-)A.

Note that the time dial vernier pot must be set fully counterclockwise for the relays to fall on the published time dial curves.

The operating time of the relays should agree with the published curve in accordance with TABLE IV.

4. Hi-Seismic Time Target Unit

The procedure for testing pickup and dropout is as follows. Refer to SETTINGS section for the method of changing taps.

1. Connect relay studs 1 and 2 (See Figure 12) to a DC source, ammeter, and loadbox so that the current can be controlled over a range of 0.1 to 2.0 amperes.
2. Block the telephone-type relay TOC closed. Reset the target in the "DOWN" position.
3. Increase the current slowly until the target unit picks up. Lower current until the unit drops out. Pickup and dropout should be within the limits of Table VIII.

TABLE VIII

TAP	PICKUP AMPERES	DROPOUT AMPERES
0.2	0.15 - 0.195	0.05 or more
2.0	1.50 - 1.95	0.50 or more

4. When tests are complete, BE SURE to unblock the telephone relay TOC.

INSTALLATION PROCEDURE

A. INTRODUCTION

The location should be clean and dry, free from dust and excessive vibration, and well lighted to facilitate inspection and testing.

The relay should be mounted on a vertical surface. The outline and panel drilling diagram is shown in Figure 15.

The internal connection diagram for the SFC151D(-)A relay is shown in Figure 12. If examination or the tests indicate readjustment is necessary, refer to the section titled **SERVICING**.

B. RELAY SURGE PROTECTION

The relays covered by this instruction book are equipped with a terminal designated as "surge ground" (See internal connection diagram Figure 12). This terminal must be connected to ground along with the relay case. The purpose of this connection is to eliminate high frequency transient potential differences between relay case, cradle, and solid state circuitry.

For proper connection, one of the mounting studs or screws should be permanently connected to ground by a conductor not less than No. 12 B&S gage copper wire or its equivalent. This connection is made to ground the relay case and relay cradle through the cradle latch. In addition, the surge ground stud must tied to ground with a lead as short as possible preferably 10 inches

or less to reach a solid ground connection. This is necessary to ensure that surge protection networks in the relay perform to give maximum surge protection.

Surge capacitors used in surge protection networks are not suitable for AC hipot testing (See HIPOT CAPABILITY). They are not subjected to high frequency surge potentials of any appreciable level. Their impedance at surge frequencies is very low, less than one ohm usually, and the various source and circuit impedances along the surge path to the relay usually limit the surge currents to less than 25 amperes. Therefore, the surge voltage drop across a surge capacitor is small.

C. TEST PLUGS

The relay may be tested without removing it from the panel by using a 12XLA131A test plug. This plug makes connections only with the relay and does not disturb any shorting bars in the case. Of course, the 12XLA12A test plug may also be used. Although this test plug allows greater testing flexibility, it also requires CT shorting jumpers and the exercise of greater care since connections are made to both the relay and the external circuitry. Additional information on the XLA test plugs may be obtained from GEI-25372.

D. SETTINGS

1. Time-overcurrent Unit

The three adjustments used in setting the time-overcurrent unit are the current tap block, the time dial, and the time dial vernier pot. These adjustments are on the front of the relay and can be seen in Figure 13.

a. Tap Setting

The minimum current at which the relay will close its contacts is determined by the setting of the links in the current tap block. This tap block is on the front center of the printed circuit card. The tap block is arranged so that the tap setting of the relay is additive; that is, the tap setting is equal to the minimum tap in the range of the relay plus the sum of the weights of each of the links that is in the "in" position. The weight of each link is given on the tap plate directly below the tap block assembly.

Links that show their broad side when viewed from the front of the relay are in the "in" position and influence the tap setting of the time unit. Links which are seen edgewise from the front of the relay are "out" and have no influence on the tap setting.

EXAMPLE OF SETTING: For example, if it were desired to set a 0.1/0.8 amp relay for a pickup of 0.26 amps, the 0.02, 0.04, and 0.1 amp links would be set in the "in" position. All other links would be set to be "out". As indicated on the tap plate, the setting of the relay would be minimum tap (0.1 amp for a 0.1/0.8 amp relay) plus the sum of the weights of the links in the "in" position. This is $0.1 + 0.02 + 0.04 + 0.1$ or 0.26 amperes. The 0.1/0.8 relay in Figure 13 has a tap setting of 0.2 ampere.

b. Time Dial Setting

The relay has two time dial adjustments, a time dial and a time dial vernier. The time dial is a rotary switch mounted on the front right hand side of the printed circuit card. The rotary switch has positions labeled 1 through 10 corresponding to time dial settings shown on the time-current curves. The rotary switch should be set so the dot in the base lines up with the desired time number. The switch has a detent mechanism to aid in setting it, however, the detent is not positive and care should be taken to make sure that the time dial is not left between click stops, otherwise, the relay will be at the 10 time dial position.

The time dial vernier is a potentiometer which is mounted on the front of the relay in the center of the nameplate. This vernier may be used to set the relay between integer time dial curves. The vernier setting adds to the integer time dial setting of the time dial switch. The fully counterclockwise position corresponds to a time dial vernier setting factor of 0. There are two stamped marks in the nameplate for setting factors 0.5 and 1.0. Intermediate setting factors are interpolated. See Figure 13.

Approximate operating times for time dial vernier settings other than 0 are determined as follows:

$$T = T_D + K_S (T_{D+1} - T_D)$$

Where:

T = Approximate operating time

K_S = Time dial vernier setting factor

T_D = Operating time for given integer time dial setting at given multiple

T_{D+1} = Operating time for next higher integer time dial setting at given multiple $1 \leq D < 10$ Integer Time Dial Setting

EXAMPLE: Refer to Figure 11. For an integer time dial setting = 2, indicated position of vernier potentiometer = 0.4, and 5 multiples of tap applied, the time of operation is

$$\begin{aligned} T &= T_D + K_S (T_{D+1} - T_D) \\ &= T_2 + 0.4 (T_3 - T_2) \\ &= 0.535 + 0.4 (0.825 - 0.535) \\ &= 0.651 \text{ sec.} \end{aligned}$$

It should be emphasized that the time dial vernier must be set fully counterclockwise for the relay operating characteristic to be one of the integer time dial curves shown in Figure 11.

The two factory adjustments are the pickup calibration potentiometer and the time calibration potentiometer. These are small adjustable potentiometers mounted on the front left of the printed circuit card.

Note that the time dial vernier pot must be turned fully counterclockwise for the relay to have an integer time dial setting as published in the time curves.

3. Printed Circuit Card

Should a printed circuit card become inoperative, it is recommended that this card be replaced with a spare. In most instances, the user will be anxious to return the equipment to service as soon as possible and the insertion of a spare card represents the most expeditious means of accomplishing this. The faulty card can then be returned to the factory for repair or replacement.

Although it is not generally recommended, it is possible with the proper equipment and trained personnel to repair cards in the field. This means that a trouble-shooting program must isolate the specific component on the card which has failed. By referring to the internal connection diagram for the card, it is possible to trace through the card circuit by signal checking to determine which component has failed. This however, may be time consuming and if the card is being checked in place in its unit, as is recommended, will extend the outage time of the equipment.

CAUTION:

Great care must be taken in replacing components on the cards. Special soldering equipment suitable for use on the delicate solid-state components must be used and, even then, care must be taken not to cause thermal damage to the components, and not to damage or bridge over the printed circuit busses. The repaired area must be recovered with a suitable high di-electric plastic coating to prevent possible breakdowns across the printed circuit busses due to moisture or dust.

B. CONTACT CLEANING

For cleaning relay contacts, a flexible burnishing tool should be used. This consists of a flexible strip of metal with an etch-roughened surface resembling in effect a superfine file. The polishing action is so delicate that no scratches are left, yet it will clean off any corrosion thoroughly and rapidly. Its flexibility insures the cleaning of the actual points of contact. Do not use knives, files, abrasive paper or cloth of any kind to clean relay contacts.

RENEWAL PARTS

It is recommended that sufficient quantities of renewal parts be carried in stock to enable the prompt replacement of any that are worn, broken, or damaged.

When ordering renewal parts, address the nearest Sales Office of the General Electric Company, specify quantity required, name of the part wanted, and the complete model number of the relay for which the part is required.

Figure 1 (0269A3029) External Connections for DC SFC

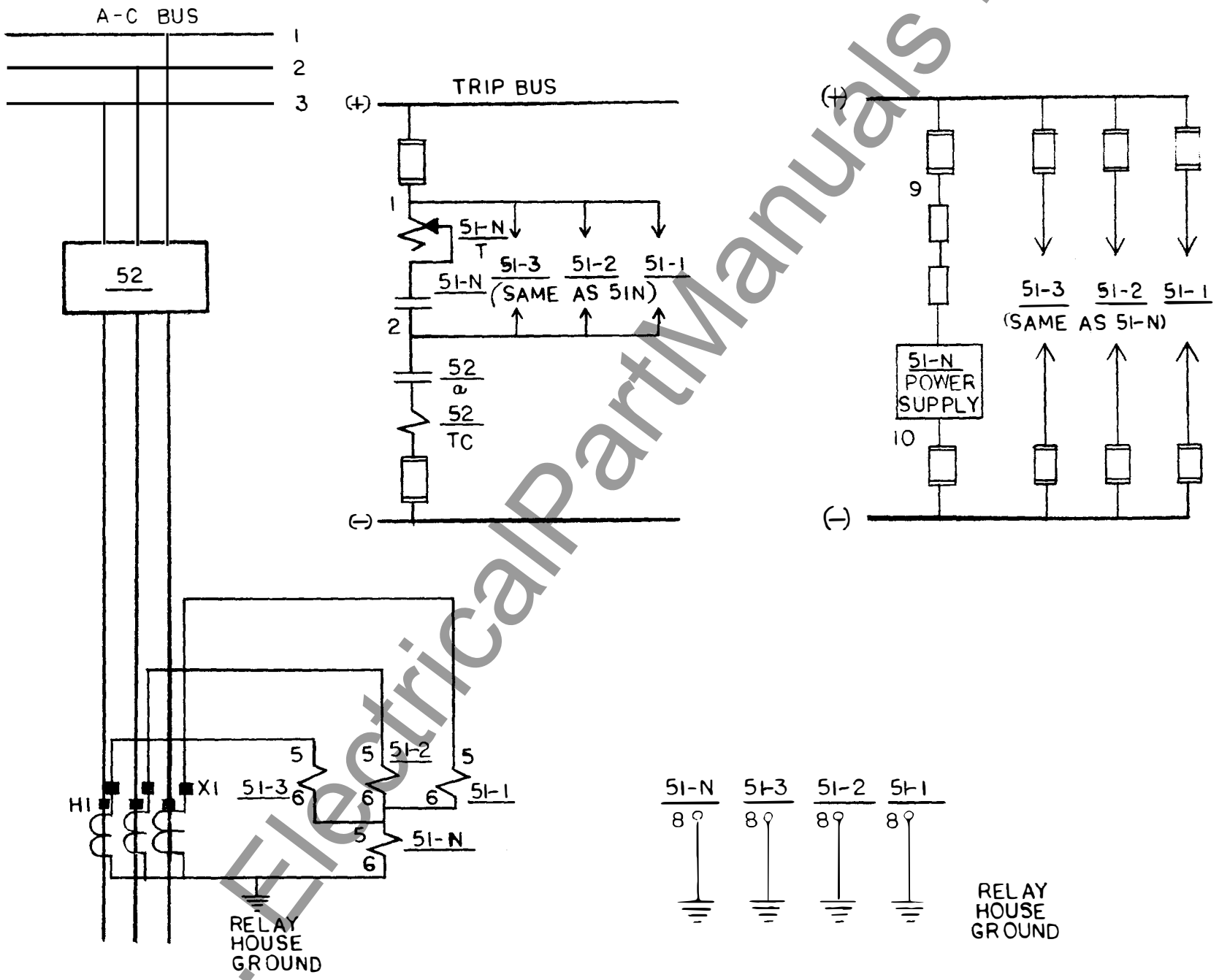
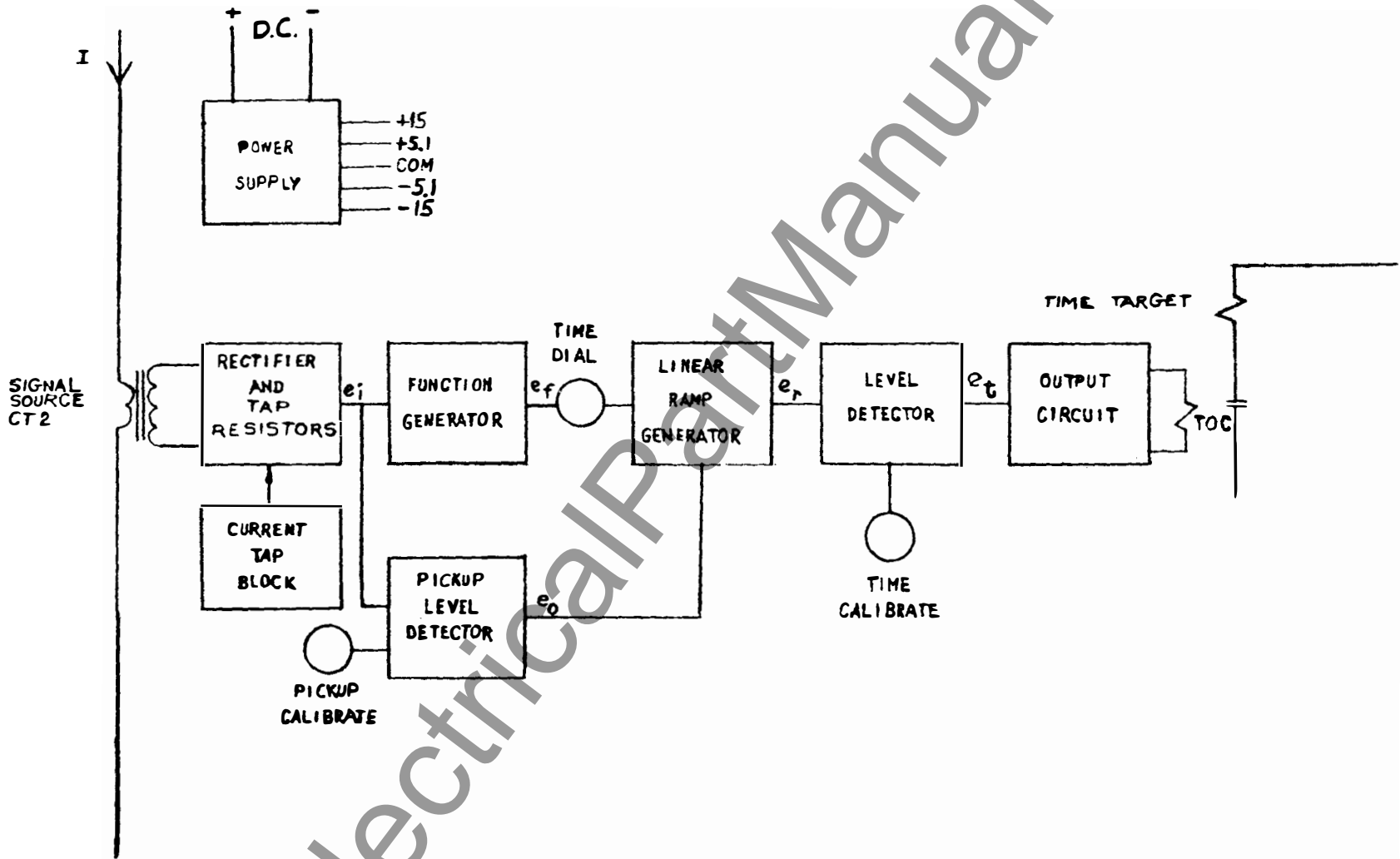

Figure 2 (0269A3031) Functional Block Diagram of SFC151D(-)A



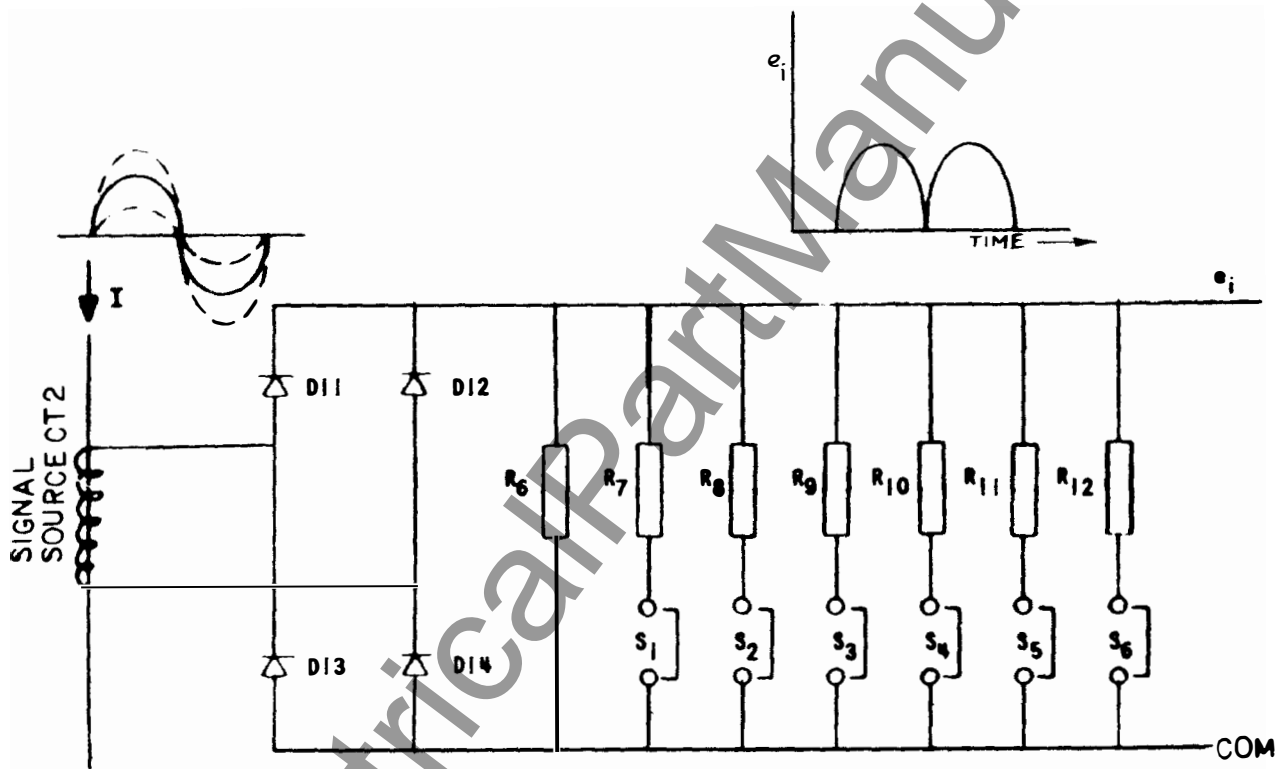
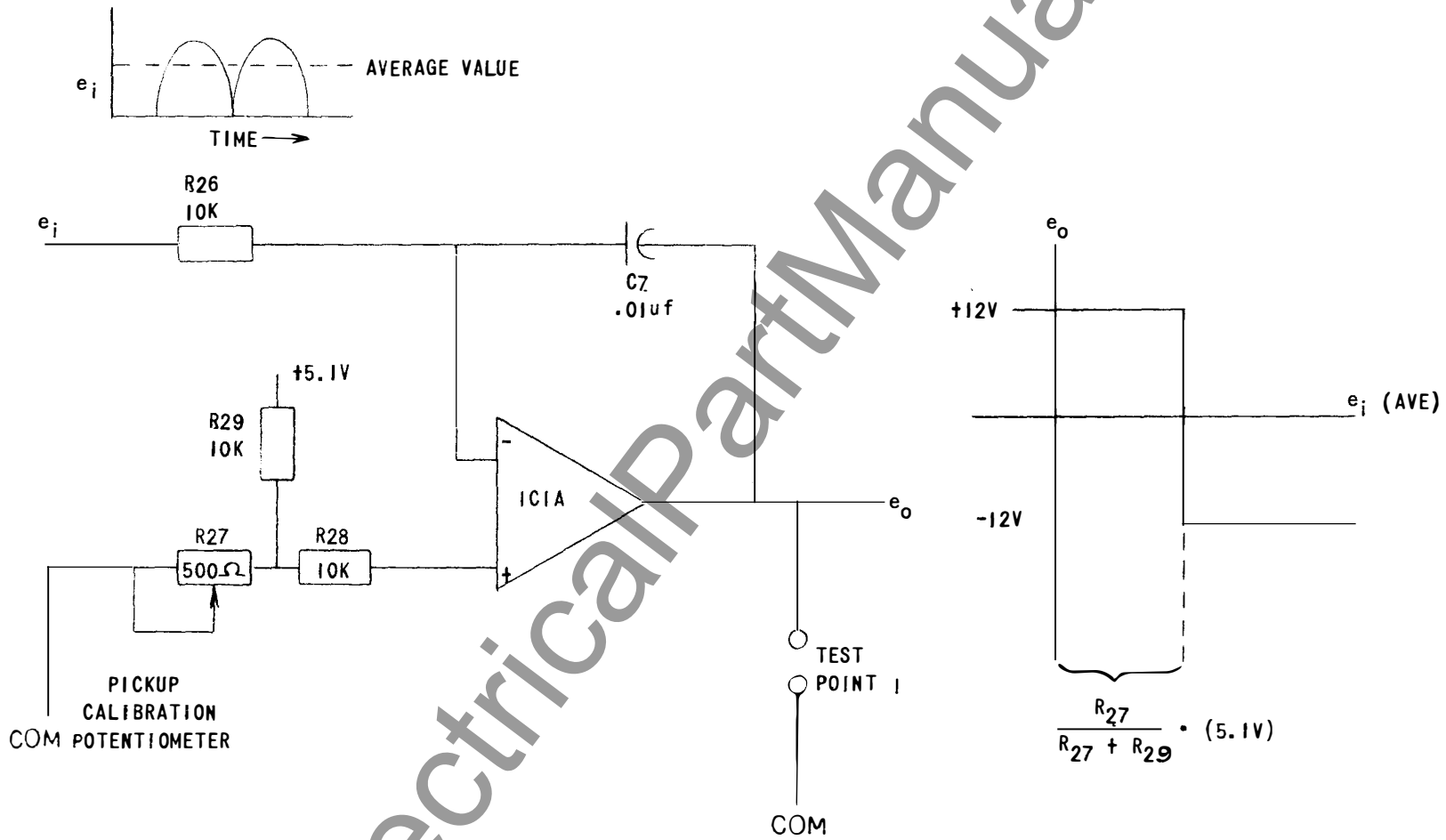
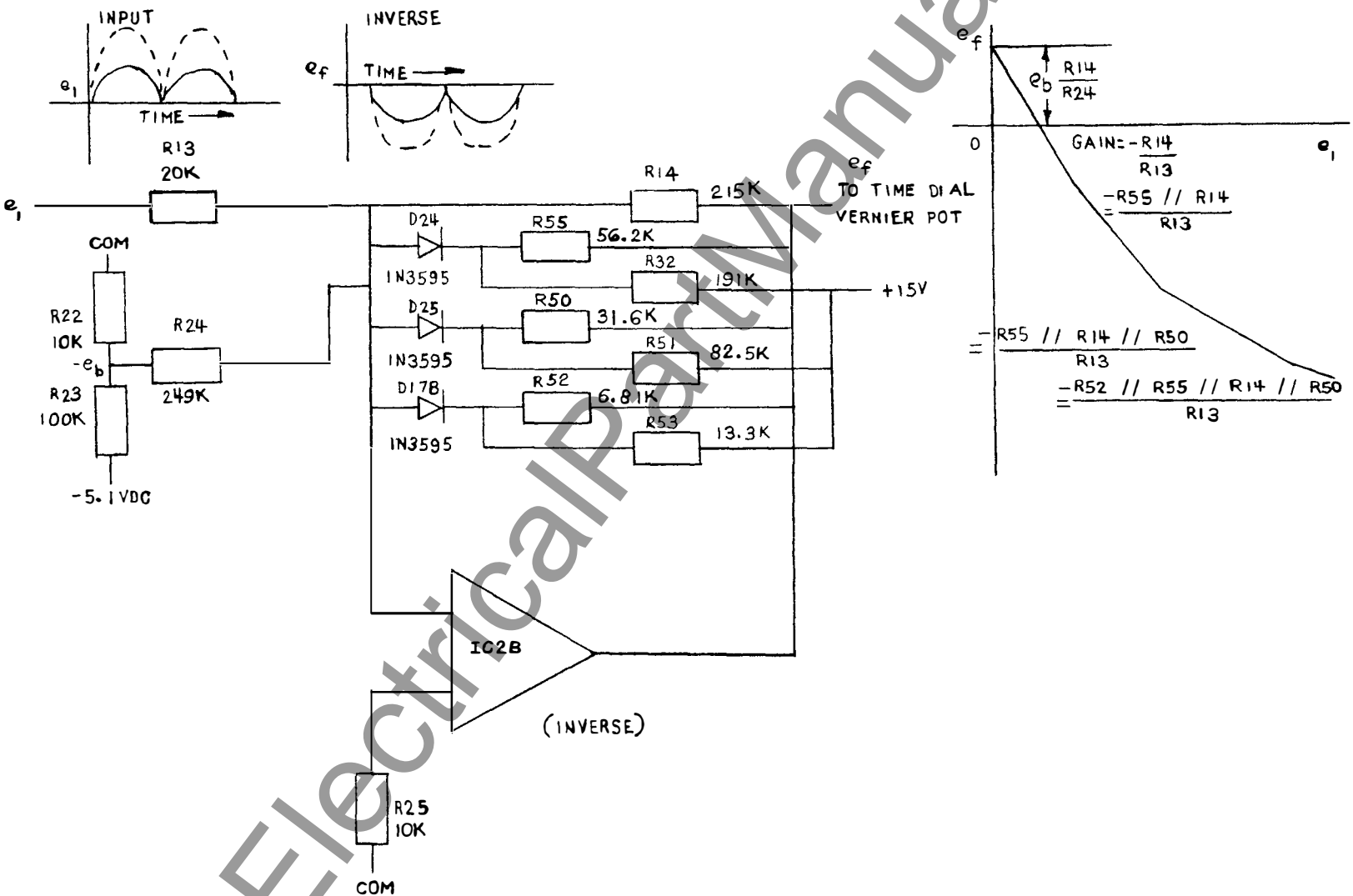

Figure 3 (0257A5010-2) Rectifier and Tap Resistors

Figure 4 (0257A5011-2) Pickup Level Detector

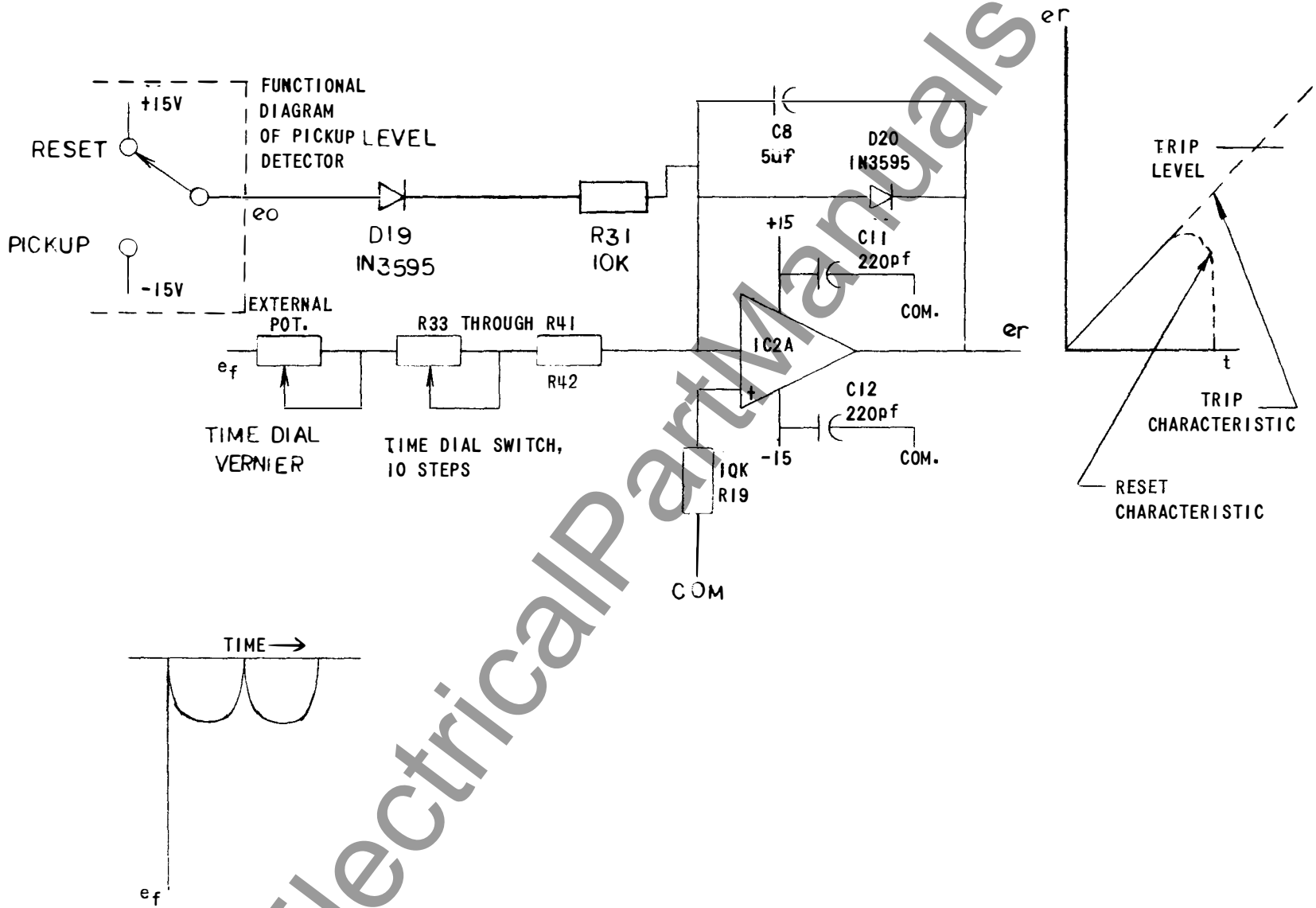



*Figure 5 (0269A1760-2) Function Generator-Inverse Characteristic

*Revised since last issue

Figure 6 (0257A5014-3) Linear Ramp Generator



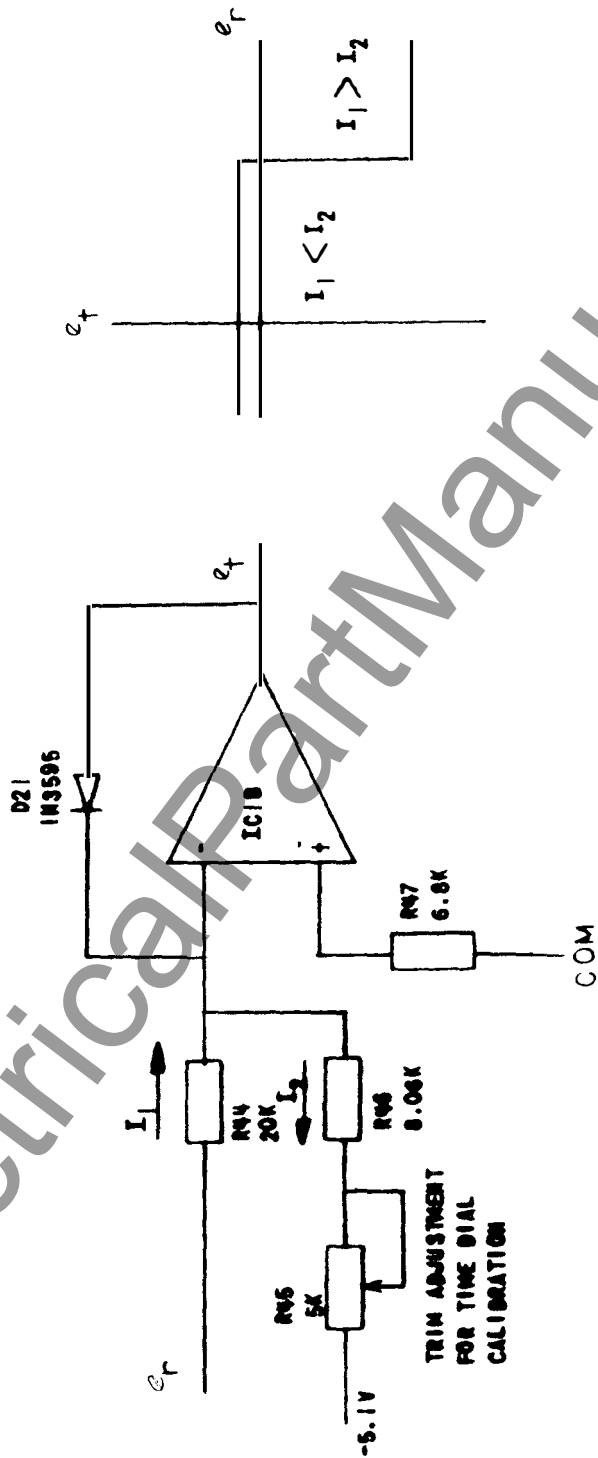
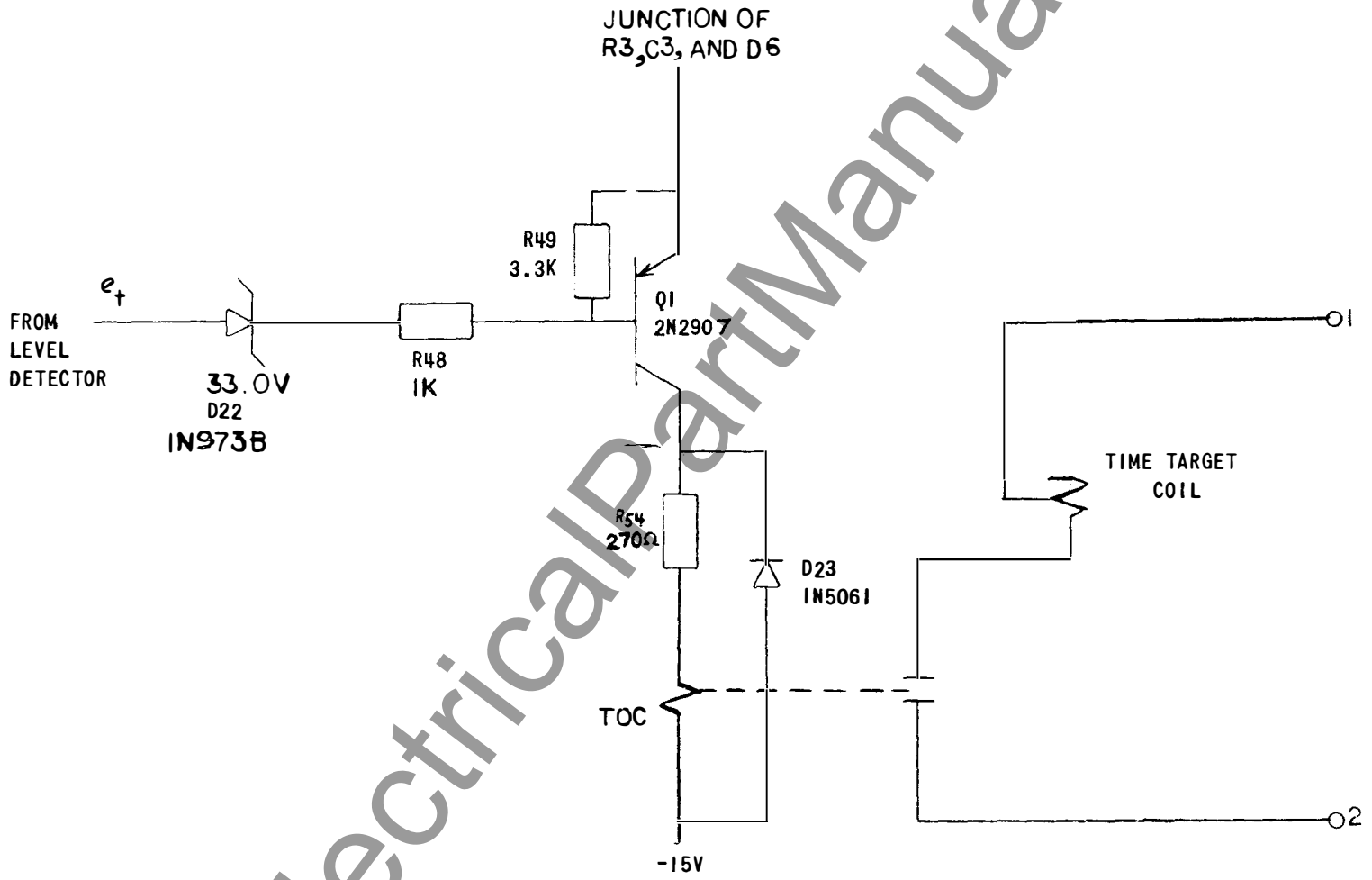

Figure 7 (0257A5015-1) Level Detector

Figure 8 (0257A5016-3) Output Circuit and Relay TOC



GEK-49777

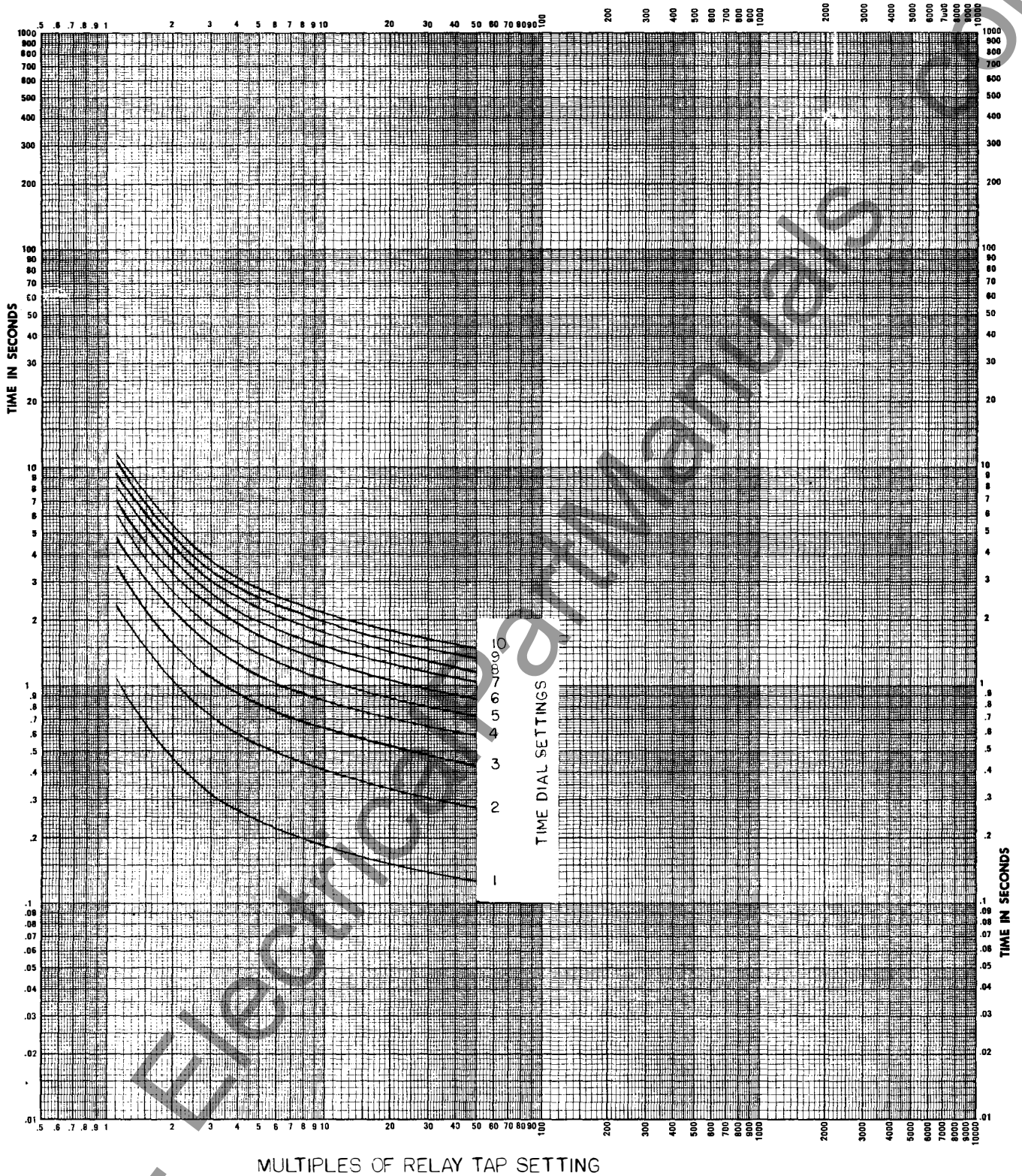

Figure 11A (0183B7887-4) Time-Current Curves SFC Time Overcurrent Relay Type-Inverse

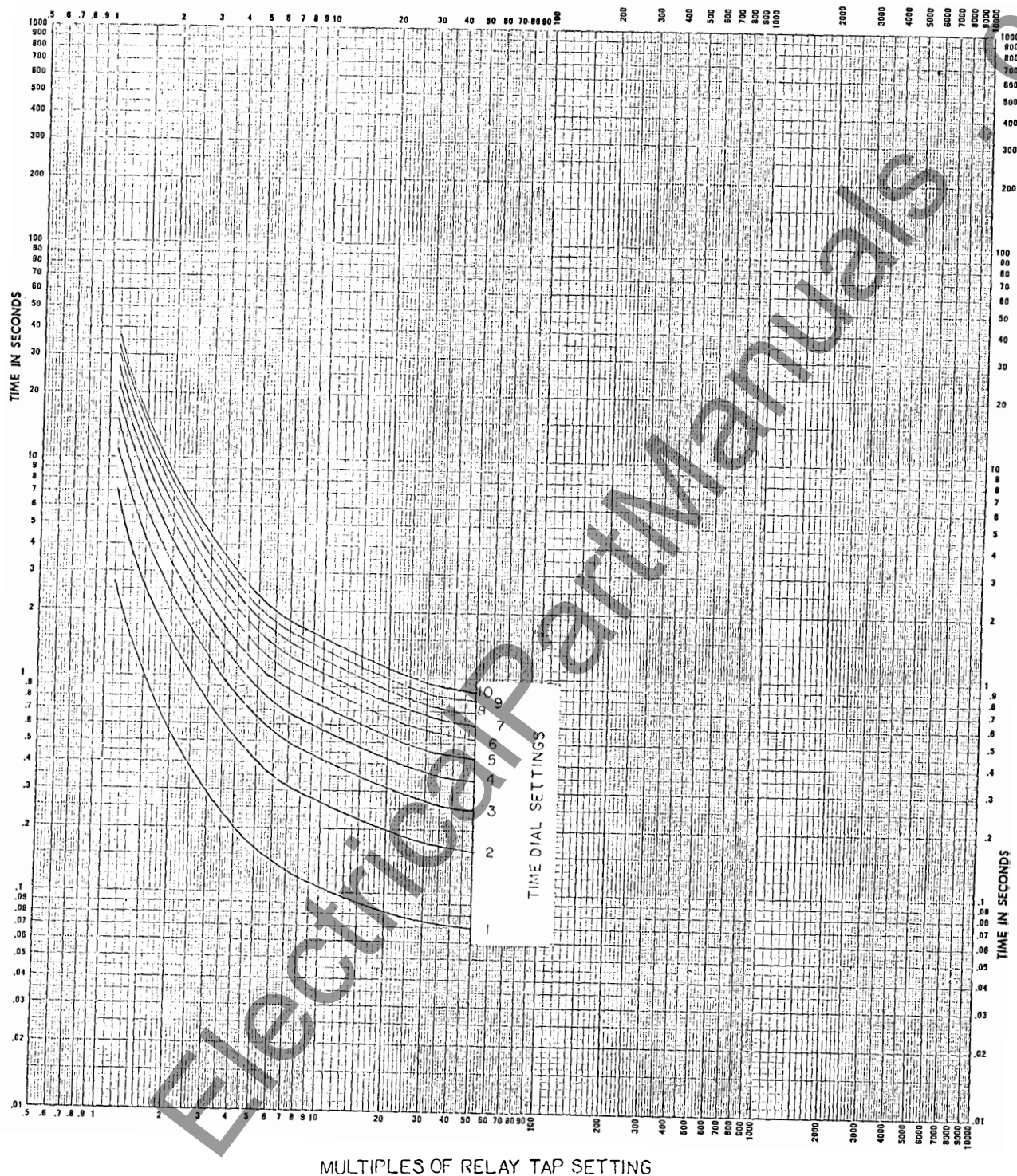
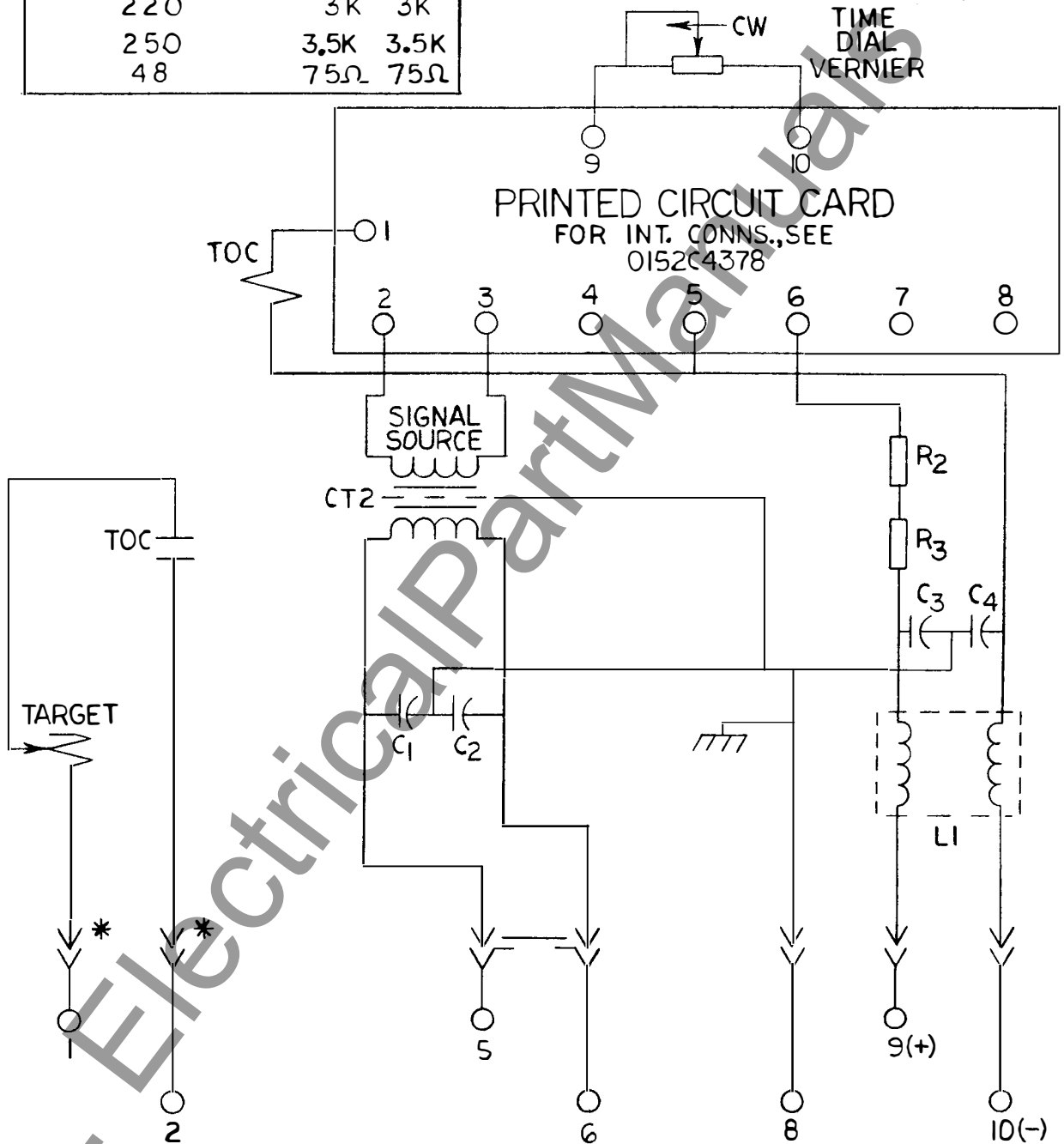

Figure 11B (0183B7888-3) Time Curve for SFC153D(-)A

*Revised since last issue

CONTROL VOLTAGE TERMINALS 9 & 10	R2	R3
125	3K	300
220	3K	3K
250	3.5K	3.5K
48	75Ω	75Ω



* = SHORT FINGER
TOC = TELEPHONE RELAY

Figure 12 (0257A8351-4) Internal Connections Diagram - Overall SFC151D(-)A Relay

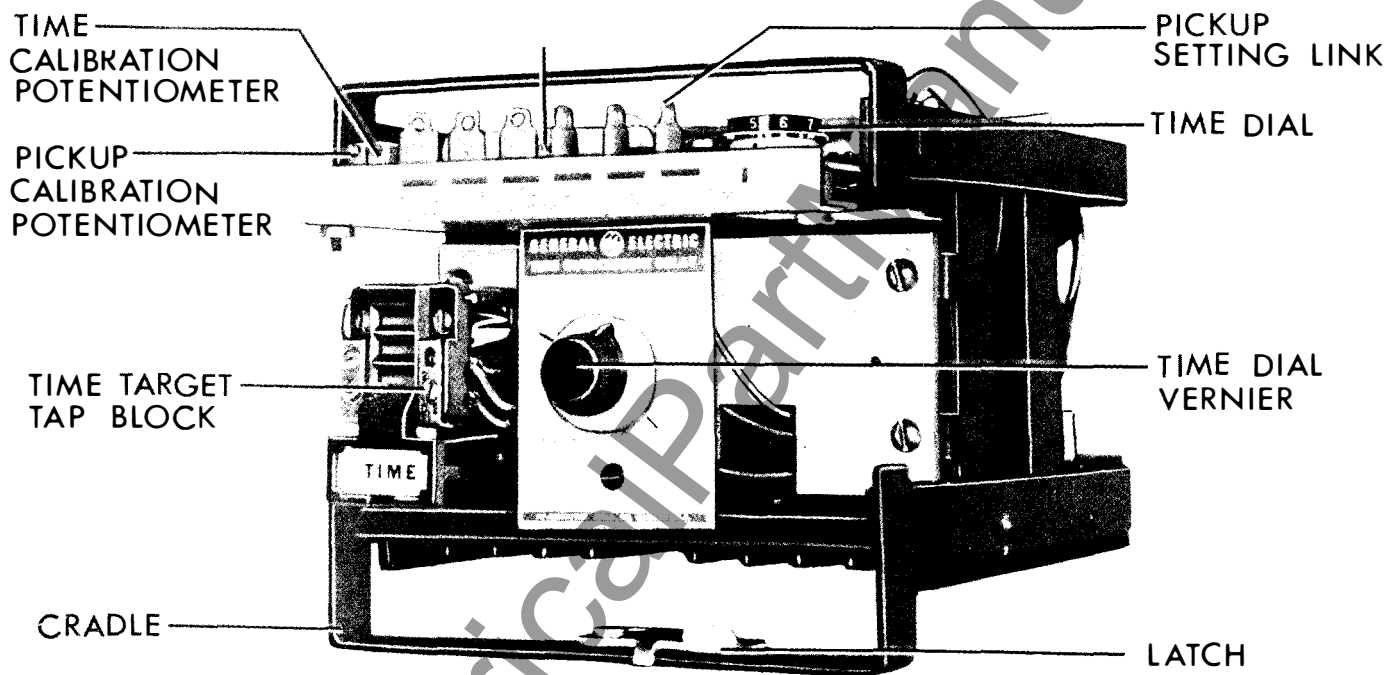

Figure 13 (8042626) SFC151D(-)A Relay - Front View
(Removed from Case)

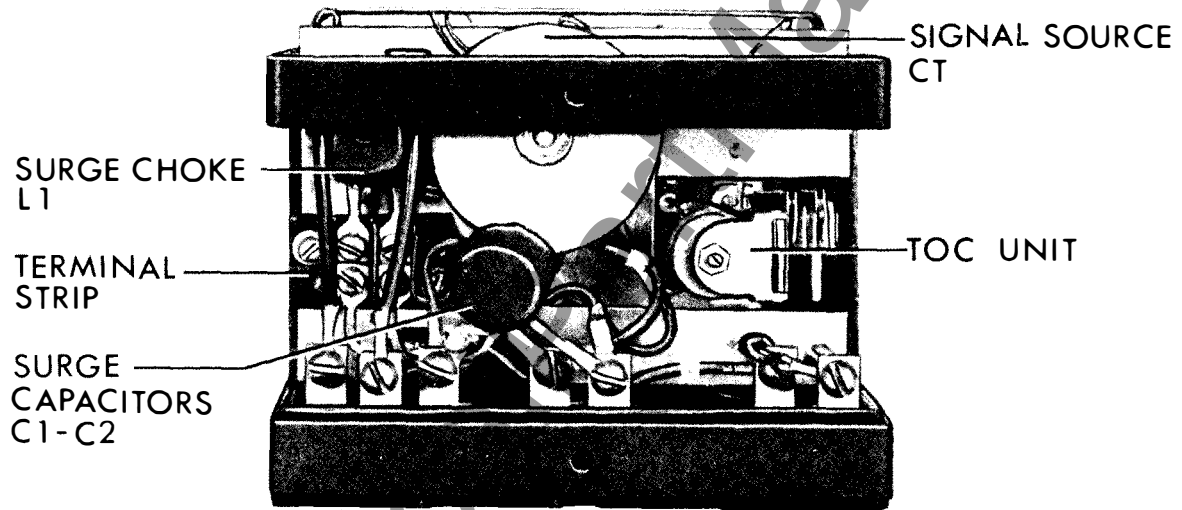

Figure 14 (8042627) SFC151D(-)A Relay - Rear View (Removed from Case)

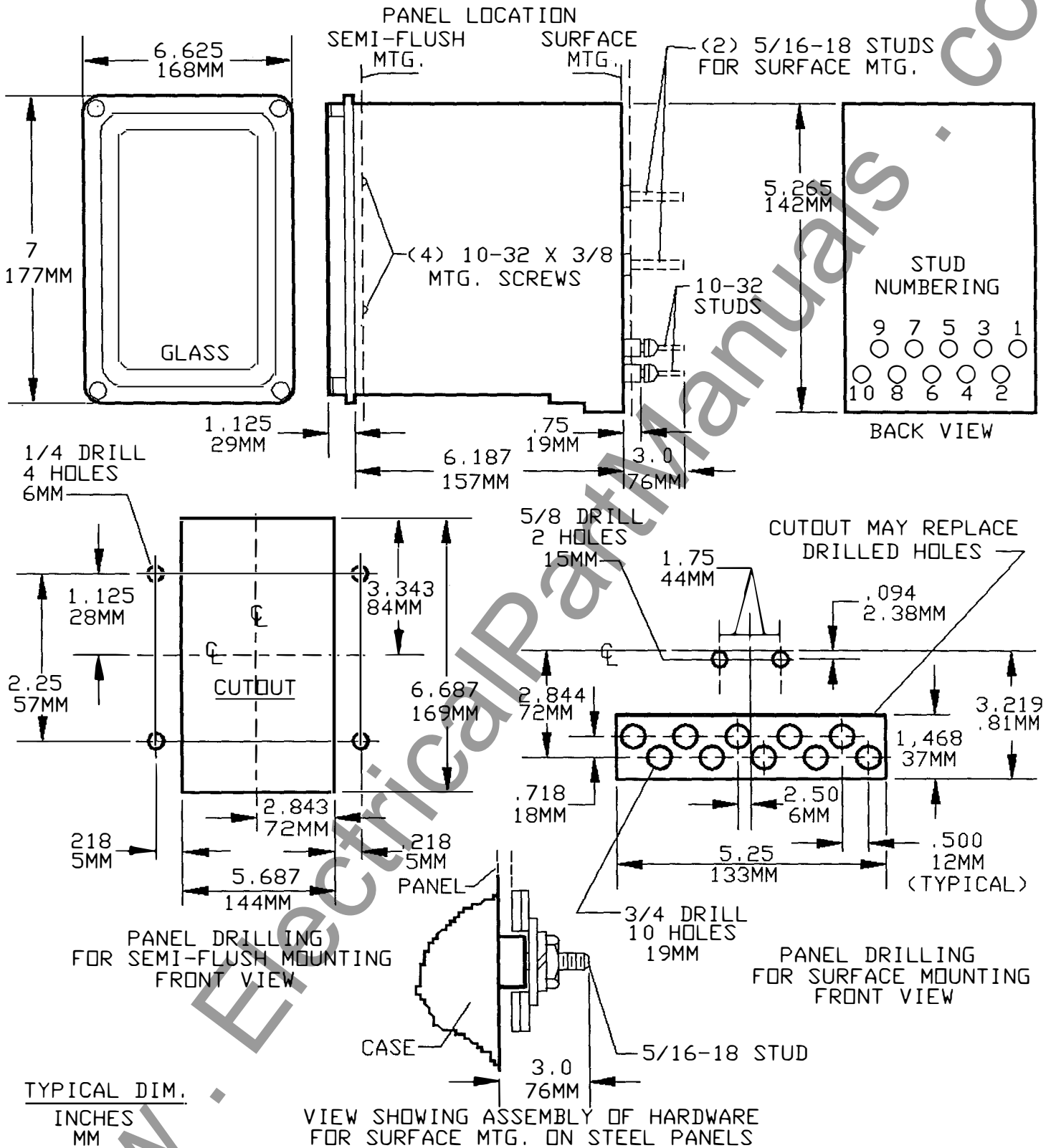

Figure 15 (0246A7968-5) Outline and Panel Drilling for the SFC151(-)A Relay

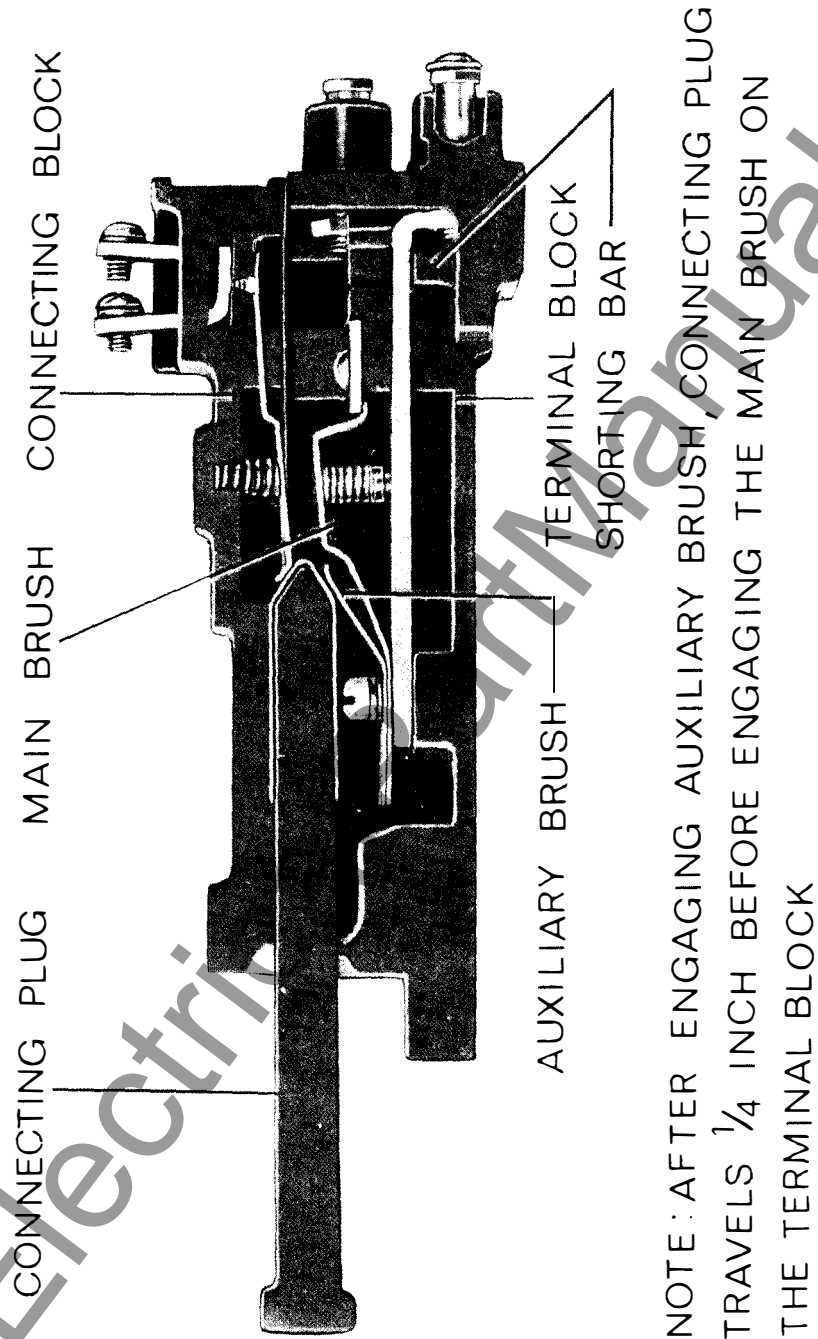

Figure 16 (8025039) Cutaway of Drawout Case Showing Position of Auxiliary Brush and Shorting Bar

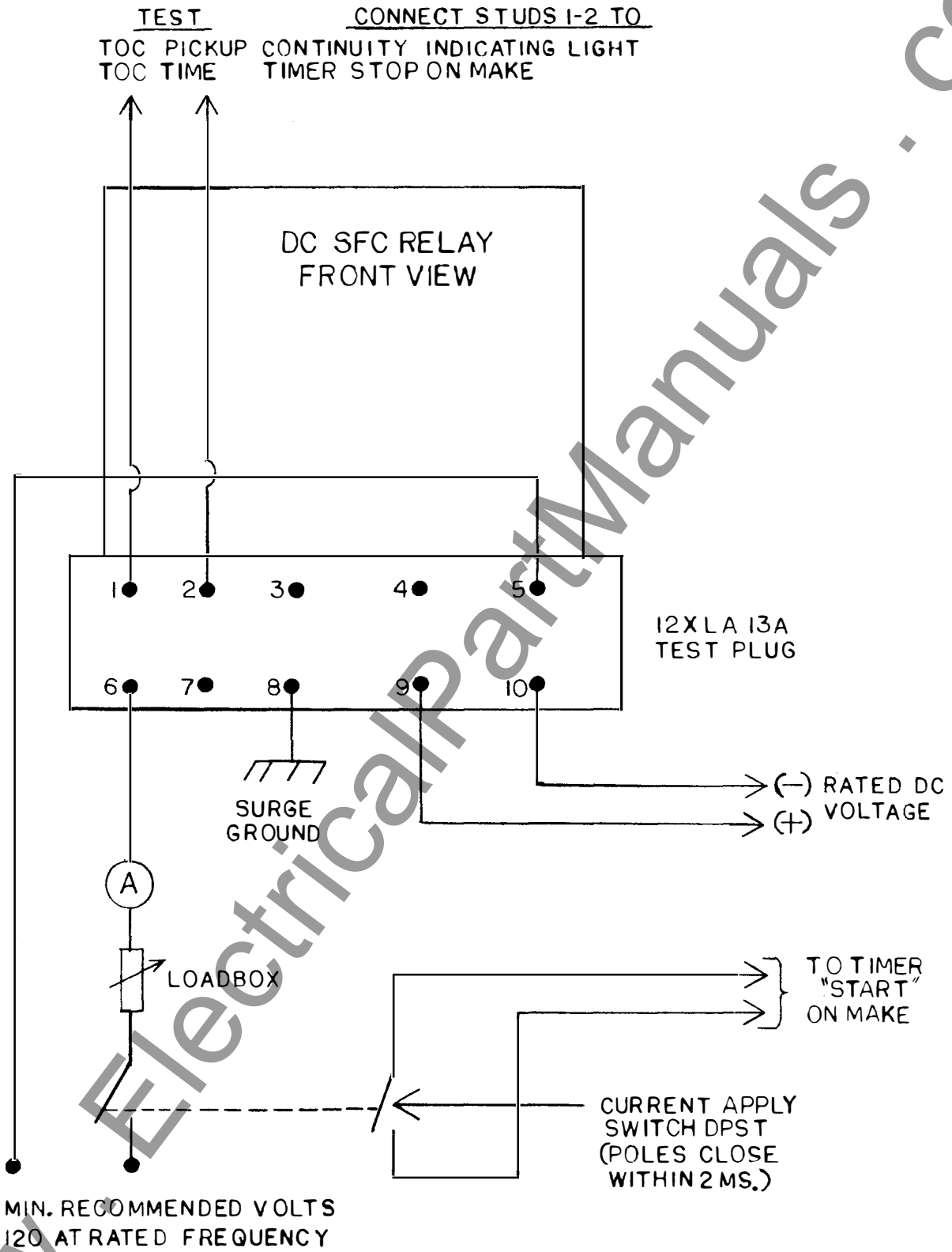

Figure 17 (0269A3032) Test Connections for SFC151D(-)A

Since the B revision of this instruction book, changes have been made in the following places:

- p.14, paragraph 4. Apply rated DC ...
- p.19, paragraph 3. Apply rated DC ...
- 4. Increase the current ...
- 6. After adjusting ...
- 5. Suddenly apply ...
- p.30, Figure 10
- p.36, figure 15.

www.ElectricalPartManuals.com

www.ElectricalPartManuals.com

***Meter and Control
Business Department***

(11/92) (1000)

General Electric Company
Protection and Control
205 Great Valley Parkway
Malvern, Pennsylvania 19355-0715