



INSTRUCTIONS

ANGLE-IMPEDANCE RELAY

TYPES:

CEX57D
CEX57E
CEX57F

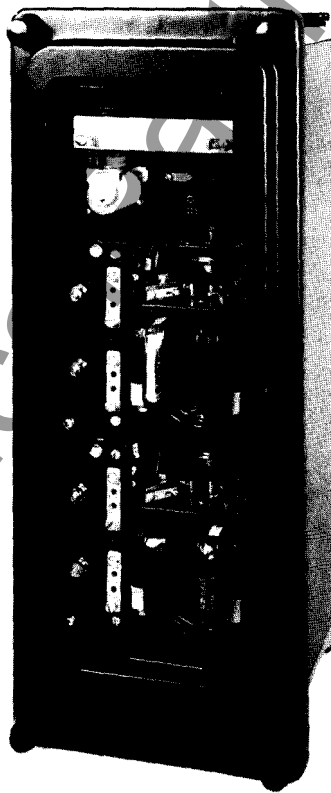

*GE Meter and Control
205 Great Valley Parkway
Malvern, PA 19355-0715*

By selecting values for T_B and T_R , the characteristic can be adjusted to be at any distance from 0.5 to 30 ohms from the origin. This 30 ohm limitation is based on T_R never being less than ten percent, its minimum recommended value.

The angle of maximum torque (θ) can be adjusted to be any angle between 5 degrees lead and 35 degrees lead for the top unit. The bottom is identical to the top unit, except its polarity is reversed so that the maximum torque angle is adjustable from 5 plus 180, or 185 degrees, to 35 plus 180, or 215 degrees.

The upper potentiometer on each unit (P1 for the upper unit and P2 for the lower unit) is used to set the angle of maximum torque. With the potentiometer set for zero ohms, the angle of maximum torque will be between 25 and 30 degrees (current leads voltage). If a jumper is added to connect stud 13 to stud 14, and a second jumper to connect stud 15 to stud 16, then the angle of maximum torque can be adjusted to be between 5 degrees and 25 degrees by using the P1 potentiometer for the upper unit, and the P2 potentiometer for the lower unit. If jumpers are not added, then these same two potentiometers (P1 for the upper unit and P2 for the lower unit) can be used to adjust the angle of maximum torque to be between 30 and 35 degrees. Angle of maximum torque can be set between 25 and 30 degrees using these same two potentiometers. Whether the jumpers should be added or not will vary from relay to relay, and will have to be determined by test of the relay actually being adjusted.

CHARACTERISTICS

ANGLE-IMPEDANCE UNIT

The angle-impedance unit characteristic is a straight line when plotted on an R-X diagram. The shortest distance from the characteristic to the origin is the minimum relay reach. The minimum relay reach is determined by two sets of taps. The two tap plugs in the current circuits set the basic minimum reach (T_B). The tap plugs in the restraint circuit increase the basic reach as the restraint taps (T_R) are reduced from 100 percent. The reach at angle of maximum torque is equal, therefore, to:

$$Z_M = \frac{T_B}{T_R} \times 100$$

where: Z_M = minimum reach
 T_B = minimum basic reach
 T_R = restraint tap

UPPER UNIT

The angle of maximum torque is the angle that the reach, Z_M , described above, leads the "R" axis (Figure 4). This angle is adjustable from 5 to 35 degrees lead.

The reach of the angle-impedance unit at any angle is given by the following equation:

$$Z = \frac{T_B \times 100}{T_R \times \cos(\theta - \theta)} = \frac{Z_M}{\cos(\theta - \theta)}$$

where: ϕ = angle I_{AB} leads V_{AB}
 θ = angle of maximum torque

See Table II for values of T_B for the various angles of maximum torque.

LOWER UNIT

This unit is identical to the upper unit except it is polarized to have maximum torque 180 degrees from the upper unit. Therefore, the equation is:

$$Z = \frac{Z_M}{\cos(\phi - \theta + 180)}$$

The value T_B is given in Table II for various angles of maximum torque. The value of T_B is equal to the tap value when the maximum torque angle is set for five degrees. If only the upper potentiometer (P1 for the upper unit, or P2 for the lower unit) is adjusted, the value of T_R will be as shown in Table II. The value of T_B can be adjusted by using the lower potentiometer (P3 for the upper unit, or P4 for the lower unit); however, it may not be possible to make T_B equal to the tap value at all angles of maximum torque settings.

TABLE II

ANGLE OF MAXIMUM TORQUE	STUDS 13-14 STUDS 15-16	BASIC REACH OHMS (T_B)		
		0.5 OHM TAP	1.5 OHM TAP	3.0 OHM TAP
5°	Jumper	0.48 - 0.53	1.43 - 1.58	2.85 - 3.15
10°	Jumper	0.41 - 0.47	1.22 - 1.40	2.43 - 2.79
15°	Jumper	0.38 - 0.42	1.14 - 1.26	2.28 - 2.52
20°	Jumper	0.34 - 0.38	1.02 - 1.13	2.04 - 2.25
25°	Jumper	0.32 - 0.36	0.94 - 1.07	1.89 - 2.13
30°	Open	0.31 - 0.37	0.92 - 1.11	1.83 - 2.22
35°	Open	0.35 - 0.40	1.05 - 1.20	2.10 - 2.40

TAPPED AUTOTRANSFORMER

The reach in ohms of the angle-impedance may be adjusted by two taps on the autotransformer. The tap block and the tap plugs are located on the right side of the relay. The two tap leads marked #1 control the upper unit, and the two tap leads marked #2 control the lower unit. The upper #1 and #2 tap leads should be connected to a tap in the upper half of the block (zero to ten percent). The lower #1 and #2 tap leads should be connected to a tap in the lower half of the block (10 to 90 percent). The restraint tap setting, T_R , is the sum of the two tap values into which the #1 or #2 leads

are connected. For example, if the upper #1 lead is put in the 5 tap, and the lower #1 lead is put in the 60 tap, then the #1 tap setting, T_R is 5 plus 60, or 65. T_R should not be set for less than ten percent.

BURDENS

CURRENT CIRCUIT

The current burden imposed by each current circuit at five amperes is listed in Table III.

TABLE III

AMPS	HERTZ	BASIC OHM TAP	R	X	PF	WATTS	VA
5	60	0.5	0.10	0.09	0.72	2.41	3.35
5	60	1.5	0.12	0.10	0.77	3.06	3.95
5	60	3.0	0.16	0.12	0.80	4.11	5.13
5	50	0.5	0.09	0.08	0.74	2.14	2.89
5	50	1.5	0.11	0.08	0.80	2.75	3.45
5	50	3.0	0.14	0.10	0.81	3.59	4.41

POTENTIAL CIRCUIT

The maximum potential burden imposed by the two units in the relay is shown in Table IV.

TABLE IV

VOLTS	HERTZ	R	X	PF	WATTS	VA
120	60	386	536	0.59	12.74	21.8
120	50	497	-523	0.69	13.74	20.0

The potential burden is maximum when the restraint taps, T_R , are set for 100 and the angle of maximum torque is near 25 degrees lead.

At any tap setting, T_R , the potential burden for each unit will be as follows:

$$\text{Watts} + j\text{Vars} = (A + jB) \times \left(\frac{T_R}{100}\right)^2$$

where: A = watts, when $T_R = 100$
 B = vars, when $T_R = 100$

See Table V for values of A and B.

*

TABLE V

VOLTS	HERTZ	MAXIMUM TORQUE ANGLE (LEAD)	JUMPERS 13-14 AND 15-16	WATTS (A)	WATTS (B)
120	60	5°	ON	5.20	-2.70
120	60	10°	ON	5.70	-3.50
120	60	25°	ON	6.30	-6.50
120	60	30°	OFF	6.20	8.20
120	60	35°	OFF	6.40	7.55
120	50	5°	ON	5.15	-2.30
120	50	10°	ON	5.90	-3.33
120	50	25°	ON	6.95	-7.20
120	50	30°	OFF	6.60	4.83
120	50	35°	OFF	6.30	4.00

The total potential burden will be the sum of the burden from each unit. Normally both units will be set for the same reach and maximum torque angle, so it will only be necessary to calculate the burden for one unit. This value will be the burden on each of the two potential devices.

The burden measured on any unit may vary plus or minus ten percent from the instruction book values, due to allowable tolerances on capacitors and coils.

CALCULATION OF SETTINGS

The exact settings to be made on the ohm units in Type CEX57 relays will depend on the particular application.

When used in blinder applications, the primary objective is to restrict the tripping area of the tripping units to avoid operation on load impedance. Thus, the reach setting should be made so that operation is prevented during maximum load flow or stable power swing conditions. The angle setting should be made so that the ohm units will plot parallel to the protected line.

When out-of-step tripping during power swings is required, tripping during stable swings can be prevented, and the breaker duty minimized, by permitting tripping only after a favorable angle is reached. Thus, the reach settings to be made will be

dependent on particular system conditions and configuration. Specific details for determining the settings for transmission line or generator applications can be found in the appropriate instruction book for Type NAA or GSY relays, as mentioned earlier.

Once the desired reach and angle has been determined, it is only necessary to calculate and set the restraint taps to meet the desired reach. The restraint tap setting can be calculated as follows:

$$T = \frac{(100) (T_B)}{Z_M}$$

where: T = restraint tap setting in percent
 T_B = basic reach tap
 Z_M = desired reach in secondary ohms at the selected torque angle

For example, refer to Figure 3 and 4 and assume Z_M should be set to reach five ohms at the torque angle shown. Base reach taps of 0.5, 1.5 and 3.0 ohms are available. Always select the highest base reach tap that will provide the desired reach setting. For this example, use the 3.0 ohm tap. Therefore,

$$T = \frac{(100) (3.0)}{5} = 60 \text{ percent}$$

Set the restraint taps for both ohm units to 60 percent.

CONSTRUCTION

The Type CEX57 relays are assembled in a medium size, double end (M2) drawout case, having studs at both ends in the rear for external connections. The electrical connections between the relay units and the case studs are made through stationary molded inner and outer blocks, between which nests a removable connection plug, which completes the circuit. The outer blocks attached to the case have studs for the external connections, and the inner blocks have terminals for the internal connections.

Every circuit in the drawout case has an auxiliary brush, as shown in Figure 8, to provide adequate overlap when the connecting plug is withdrawn or inserted. Some circuits are equipped with shorting bars (see internal connections) and on those circuits, it is especially important that the auxiliary brush make contact as indicated in Figure 8 with adequate pressure to prevent the opening of important interlocking circuits.

The relay mechanism is mounted in a steel framework called the cradle and is a complete unit with all leads terminated at the inner block. This cradle is held firmly in the case with a latch at both top and bottom and by a guide pin at the back of the case. The connecting plug, besides making the electrical connections between the respective blocks of the cradle and case, also locks the latch in place. The cover, which is drawn to the case by thumbscrews, holds the connecting plugs in place. The target reset mechanism is a part of the cover assembly.

The relay case is suitable for either a semi-flush or surface mounting on all panels up to two inches thick and appropriate hardware is available. However, panel thickness must be indicated on the relay order to insure that proper hardware will be included.

A separate testing plug can be inserted in place of the connecting plug to test the relay in place on the panel either from its own source of current and voltage, or from other sources. Or, the relay can be drawn out and replaced by another relay which has already been tested in the laboratory.

Figure 1 shows the relay removed from its case with all major components identified. Symbols used to identify circuit components are the same as those which appear on the internal connection diagrams in Figures 9, 10 and 11.

The relays include two angle-impedance units mounted on the front of the cradle and a tapped autotransformer. The Type CEX57F also has an auxiliary unit (telephone-type) mounted at the top.

The angle-impedance unit assembly includes the four pole unit, two potentiometers, one capacitor and two tap blocks for setting basic reach.

The upper potentiometer (P1 for the top unit or P2 for the lower unit) is used to set the angle of maximum torque. The lower potentiometer (P3 for the top unit or P4 for the lower unit) is used to set basic reach to tap value.

The operating coil consists of two current coils, and both coils have three taps. These taps come to the two tap blocks mounted on the left side of the unit. These taps determine the basic reach of the unit, and both tap plugs are normally set for the same tap value. See Table II for data on how the basic reach ohms vary as the angle of maximum torque is changed.

RECEIVING, HANDLING AND STORAGE

These relays, when not included as part of a control panel will be shipped in cartons designed to protect them against damage. Immediately upon receipt of a relay, examine it for any damage sustained in transit. If damage resulting from rough handling is evident, file a damage claim at once with the transportation company and promptly notify the nearest General Electric Apparatus Sales Office.

Reasonable care should be exercised in unpacking the relay in order that none of the parts are damaged or the adjustments disturbed.

If the relays are not to be installed immediately, they should be stored in their original cartons in a place that is free from moisture, dust and metallic chips. Foreign matter collected on the outside of the case may find its way inside when the cover is removed, and cause trouble in the operation of the relay.

ACCEPTANCE TESTS

Immediately upon receipt of the relay, an inspection and acceptance test should be made to insure that no damage has been sustained in shipment, and that the relay calibrations have not been disturbed. If examination or test indicates that readjustment is necessary, refer to **SERVICING**.

VISUAL INSPECTION

Check the nameplate stamping to insure that the model number and rating of the relay agree with the requisition. Remove the relay from its case and check that there are no broken or cracked molded parts or other signs of physical damage, and that all screws are tight.

MECHANICAL INSPECTION

1. There should be no noticeable friction in the rotating structure of the units.
2. Make sure the control springs are not deformed, and that spring convolutions do not touch each other.
3. With the relay well-leveled in its upright position, the left contacts of both units must be open. The moving contacts of the units should rest against the right contact.
4. Check the location of the contact brushes on the cradle and case blocks against the internal connection diagram for the relay.
5. The rotating shaft end play should be 0.005 inch to 0.010 inch.
6. The contact gap should be 0.018 inch to 0.020 inch.
7. The contact wiper should be 0.003 inch to 0.006 inch.

ELECTRICAL CHECKS - OHM UNIT

All tests should be made with the relay in its case. Before any electrical checks are made on the units, the relay should be connected as shown in Figure 12B, and allowed to warm up for approximately 15 minutes with the potential circuit alone energized at rated voltage, and the restraint taps set at 100 percent. The units were warmed up prior to factory adjustment, and if they are rechecked when cold, they will have a tendency to underreach by three or four percent. Accurately calibrated meters are, of course, essential.

Check the factory setting and calibration by means of the tests described in the following sections. The units were carefully adjusted at the factory, and these settings should not be disturbed unless the following checks indicate conclusively that the settings have been disturbed. If readjustments are necessary, refer to the section on **SERVICING** for recommended procedures.

Test connections for checking correct unit operation. Jumper studs 13 to 14 and 15 to 16.

Control Spring Adjustment:

Be sure that the relay is level in its upright position. Leave the relay connected as shown in Figure 12B, and leave the restraint taps in the 100 percent position. Put the basic reach taps in the 1.5 ohm taps. With the voltage set for zero, the current required to close the left contact should be as shown below:

	<u>CEX57D</u>	<u>CEX57E</u>	<u>CEX57F</u>
Amperes to Close Left Contact	1.2-1.5	0.85-1.00	1.2-1.5

Clutch Adjustment:

- * Remove jumpers from studs 13-14 and 15-16. With the connections shown in Figure 12B, set the phase angle to 185 degrees (I leads V) for the top unit, or 5 degrees (I leads V) for the lower unit. Put restraint taps in 100 percent, basic reach taps in the 3.0 ohm taps, and set for rated voltage. Increase the current until the clutch just slips. The current should be between 22 and 30 amps. The clutch slip can be detected by observing the nut at the top of the rotating shaft assembly. This nut will turn when the clutch slips, but the moving contact will remain in contact with the right stationary contact.

Ohmic Reach

Connect the relay per Figure 12B. Set the phase angle to maximum torque (I leads V by five degrees if factory adjusted). With restraint taps on 100 percent, basic reach taps on 1.5 ohms, and V = 30 volts, determine current to just close the left contact of the upper unit. The current should be between 9.7 and 10.3 amperes.

For the lower unit, repeat as above, except set the phase angle to 185 degrees (I leads V).

Note that the mho units see a phase-to-phase fault of twice the basic minimum reach for the test conditions.

Angle of Maximum Torque:

To check the angle of maximum torque, again use the connections of Figure 12B. Set the phase shifter to maximum torque angle, plus 30 degrees. The current to close the left contact should be 82 to 91 percent of the value determined in "Ohmic Reach" above.

Repeat the above check with the phase angle set for maximum torque angle, minus 30 degrees. The current to close the left contact should also be 82 to 91 percent of the value determined in "Ohmic Reach."

ELECTRICAL CHECKS - AUXILIARY UNIT (CEX57F ONLY)

Select the proper tap for the DC voltage to be used on the relay.

Apply 75 percent of rated DC voltage to studs 1 and 11, with plus DC on stud 11. Close the left contact of both induction cylinder units. The auxiliary relay should pick up.

INSTALLATION PROCEDURE

LOCATION

The relay should be installed in a location that is clean, dry, free from dust, and well lighted to facilitate inspection and testing.

MOUNTING

The relay should be mounted on a vertical surface. The outline and panel drilling dimensions are shown in Figure 14.

CONNECTIONS

The internal connections diagrams for the relays are shown in Figures 9, 10 and 11. An elementary diagram of typical external connections is shown in Figure 5.

VISUAL INSPECTION

Remove the relay from its case and check that there are no broken or cracked component parts, and that all screws are tight.

MECHANICAL INSPECTION

Recheck the seven adjustments detailed in the MECHANICAL INSPECTION section of ACCEPTANCE TESTS.

INSPECTION

Before placing a relay into service, the following mechanical adjustments should be checked:

ANGLE-IMPEDANCE UNIT

There should be no noticeable friction in the rotating structure of the unit. The unit's moving contacts should just return to the right contact when the relay is de-energized and in the vertical position.

There should be approximately 0.005 to 0.010 inch end play in the shaft of the rotating structure. The lower jewel screw bearing should be screwed firmly into place, and the top pivot locked in place by its set screw.

If the jewel should become cracked or dirty, the screw assembly can be removed from the bottom of the unit and examined. When replacing a jewel, have the top pivot engaged in the shaft while screwing in the jewel screw.

All nuts and screws should be tight, particularly on the tap plugs.

The felt gasket on the cover should be securely cemented in place in order to keep out dust.

Determine the impedance and phase angle seen by the relays. Once the impedance and phase angle is determined, the tap value at which the relay will just operate can be calculated. It is then only necessary to reduce the tap setting of the relay until the units operate, and see how close the actual tap value found checks with the calculated value. The calculated value should take into account the shorter reach of the unit at low currents. This effect is shown in Figure 14.

A procedure to check most of the possible open circuits in the AC portion of the relay is as follows:

- (a) Open the potential circuit by removing one of the #1 and one of the #2 tap plugs. Place current taps in the 1.5 ohm taps.
- (b) With current greater than two amps flowing in the current coils, the left contact of the unit should close.
- (c) Replace the #1 and #2 restraint tap plugs. With 120 volts on the relay, one unit should close its right contact, while the other unit should have increased torque closing the left contact. Which unit has its left contact closed, and which has its right closed, is determined by the direction of the current in the current circuit, relative to the voltage on the potential circuit.

PERIODIC CHECKS AND ROUTINE MAINTENANCE

In view of the vital role of protective relays in the operation of a power system, it is important that a periodic test program be followed. The interval between periodic checks will vary depending upon environment, type of relay and the user's experience with periodic testing. Until the user has accumulated enough experience to select the test interval best suited to his individual requirements, it is suggested that the points listed under **ACCEPTANCE TESTS** be checked at an interval of from one to two years.

CONTACT CLEANING

A flexible burnishing tool should be used for cleaning relay contacts. This is a flexible strip of metal with an etched-roughened surface, which in effect resembles a superfine file. The polishing action of this file is so delicate that no scratches are left on the contacts, yet it cleans off any corrosion thoroughly and rapidly. The flexibility of the tool insures the cleaning of the actual points of contact. Relay contacts should never be cleaned with knives, files, or abrasive paper or cloth.

SERVICING

If the unit calibrations are found to be out of limits during installation or periodic tests, they should be recalibrated as outlined in the following paragraphs. The calibrations should be made in the laboratory. The circuit components listed below, normally considered as factory adjustments, are used in recalibrating the units. The parts may be physically located on Figures 1 and 2. Their location in the relay circuit is shown on the internal connection diagrams, Figures 10, 11 and 12.

P1: Angle of maximum torque adjustment on upper unit
 P2: Angle of maximum torque adjustment on lower unit
 P3 Ohmic reach of top unit
 P4: Ohmic reach of bottom unit

NOTE: Before making pickup or phase angle adjustments on the units, they should be allowed to heat up for approximately 15 minutes, energized with rated voltage alone, and the restraint tap leads set for 100 percent. It is also important that the relay is mounted in an upright position so that the units are level.

CONTROL SPRING ADJUSTMENT

Make connections to the relay as shown in Figure 12B:

Set voltage to zero ohms
 Put basic reach taps in 1.5 ohm taps
 Set current to 1.0 ampere.

Insert the blade of a thin screwdriver into one of the slots in the edge of the spring adjusting ring (see Figure 2) and turn the ring until the left contact of the unit just closes. Turning the ring to the right will increase the current required to close the left contact. When the left contact just closes at 1.0 ampere, reduce the current to zero, and check that the right contact is closed.

ANGLE OF MAXIMUM TORQUE ADJUSTMENT

The angle of maximum torque is primarily controlled by the adjustment of the upper rheostat on each unit (P1 for the upper unit, or P2 for the lower unit), and by whether a jumper is applied across studs 13-14 and 15-16. The lower rheostat on each unit (P3 for the upper unit, or P4 for the lower unit), has a secondary effect on the angle of maximum torque.

For angle of maximum torque between 5 and 25 degrees, a jumper should be connected between studs 13-14, and a second jumper between studs 15-16.

For angle of maximum torque between 30 and 35 degrees, no connections should be made to studs 13, 14, 15 or 16.

For angle of maximum torque between 25 and 30 degrees, determine whether the jumpers between studs 13-14 and studs 15-16 should or should not be used. This will vary from unit to unit, depending upon actual value of capacitors C1 and C2.

The relays are shipped from the factory with the maximum torque angle set for five degrees (I leads V). For a different angle of maximum torque, proceed as follows:

1. Connect the relay as shown in Figure 12B.
2. Jumper studs 13-14 and studs 15-16 if required.
3. Put basic reach taps in 1.5 ohm tap.
4. With restraint taps set for 100 percent, apply 60 volts to relay.
5. Set current to 15 amperes.
6. Turn the phase shifter and determine the two angles at which the left contact just closes (angle of zero torque). Find the angle of maximum torque as follows:
 - a) Add the two angles found above
 - b) Divide the sum by two. This will be the angle of maximum torque for the lower unit. For the upper unit, subtract 180 degrees from the value to get the maximum torque angle.

For example: Assume the top unit closes its left contact at 52 degrees and 326 degrees. Adding the two values $52 + 326 = 378$ degrees. Dividing by two equals 189 degrees; subtracting 180 degrees equals nine degrees for the angle of maximum torque.

7. If studs 13-14 and studs 15-16 are jumpered, the upper rheostat on the unit should be turned clockwise to make the angle of maximum torque lower; or counterclockwise to make the angle of maximum torque higher.
8. If studs 13-14 and studs 15-16 are not jumpered, the upper rheostat on the unit should be turned counterclockwise to make the angle of maximum torque lower, and clockwise to make the angle of maximum torque higher.
9. If the upper rheostat is turned completely counterclockwise, the rheostat will be at zero ohms, and the angle of maximum torque will be approximately the same whether studs 13-14 and studs 15-16 are shorted or left unshorted. This is the angle that determines whether to short studs 13-14 and studs 15-16. For angles of maximum torque below this value, studs 13-14 and studs 15-16 must be jumpered. For angles of maximum torque above this value, studs 13-14 and studs 15-16 should not be shorted. This value will be between 26 and 30 degrees.

BASIC REACH OHMS

When the angle of maximum torque is set for the desired value by the tests outlined in ANGLE OF MAXIMUM TORQUE ADJUSTMENT, the basic reach should be checked as follows:

1. Turn the phase shifter to set test circuit to angle of maximum reach.

2. Set the voltage to the values given in Table VI, and determine the current to just cause the left contact to close. This value should be as shown in Table VI.

CORE ADJUSTMENT (IF REQUIRED)

The core adjustment is made as follows:

1. Adjust the control spring until the moving contact is not touching either the right or left contact when the relay is de-energized.
2. Apply rated voltage to studs 3-4 for 15 minutes to allow the potential circuit to heat up.
3. Adjust the core until the moving contact remains in the same position with studs 3-4 energized at rated voltage, or with studs 3-4 de-energized.

TABLE VI

ANGLE OF MAX. TORQUE	PHASE ANGLE SETTING		VOLTAGE ON STUDS 3-4	CURRENT PICKUP	BASIC OHMS
	TOP UNIT	BOTTOM UNIT			
5°	5	185	40	12.7-14.0	1.43-1.58
10°	10	190	40	14.3-16.4	1.22-1.40
15°	15	195	40	15.9-17.6	1.14-1.26
20°	20	200	40	17.7-19.6	1.02-1.13
25°	25	205	40	18.7-21.0	0.95-1.07
30°	30	210	40	18.0-21.7	0.92-1.11
35°	35	215	40	16.7-19.1	1.05-1.20

There should be no current in the current circuits (studs 5-6 and studs 7-8) when the core adjustment test is being made.

When the core adjustment test is completed, reset the control spring per the paragraph on CONTROL SPRING ADJUSTMENT.

RENEWAL PARTS

Sufficient quantities of renewal parts should be kept in stock for the prompt replacement of any that are worn, broken or damaged.

When ordering renewal parts, address the nearest Sales Office of the General Electric Company. Specify the name of the part wanted, quantity required, and complete nameplate data, including the serial number, of the relay.

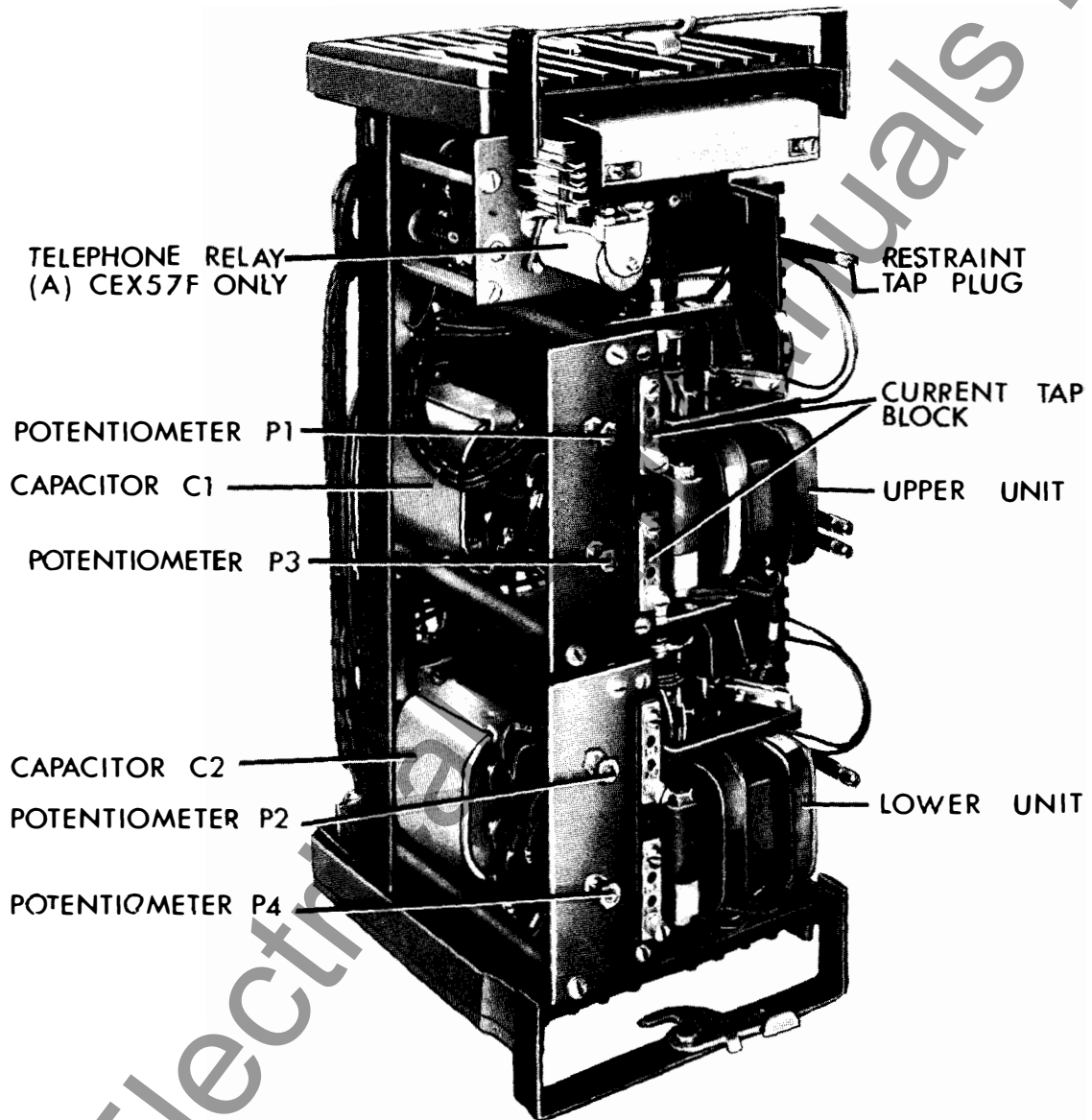

Figure 1 (8042959) Type CEX57 Relay Withdrawn from Case

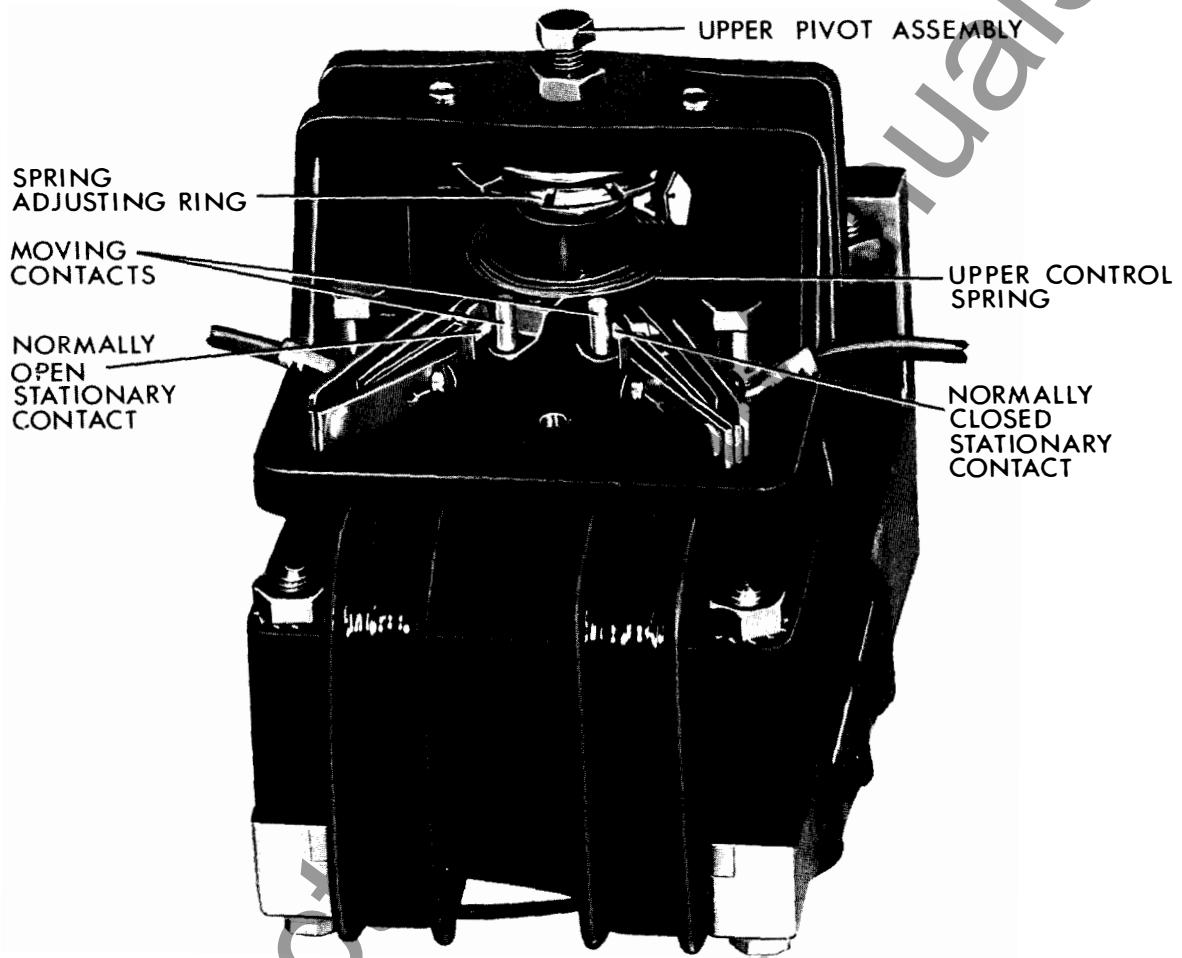

Figure 2 (8041447) Four-Pole Induction Cylinder Unit Typifying Construction of the Units in Type CEX57 Relays

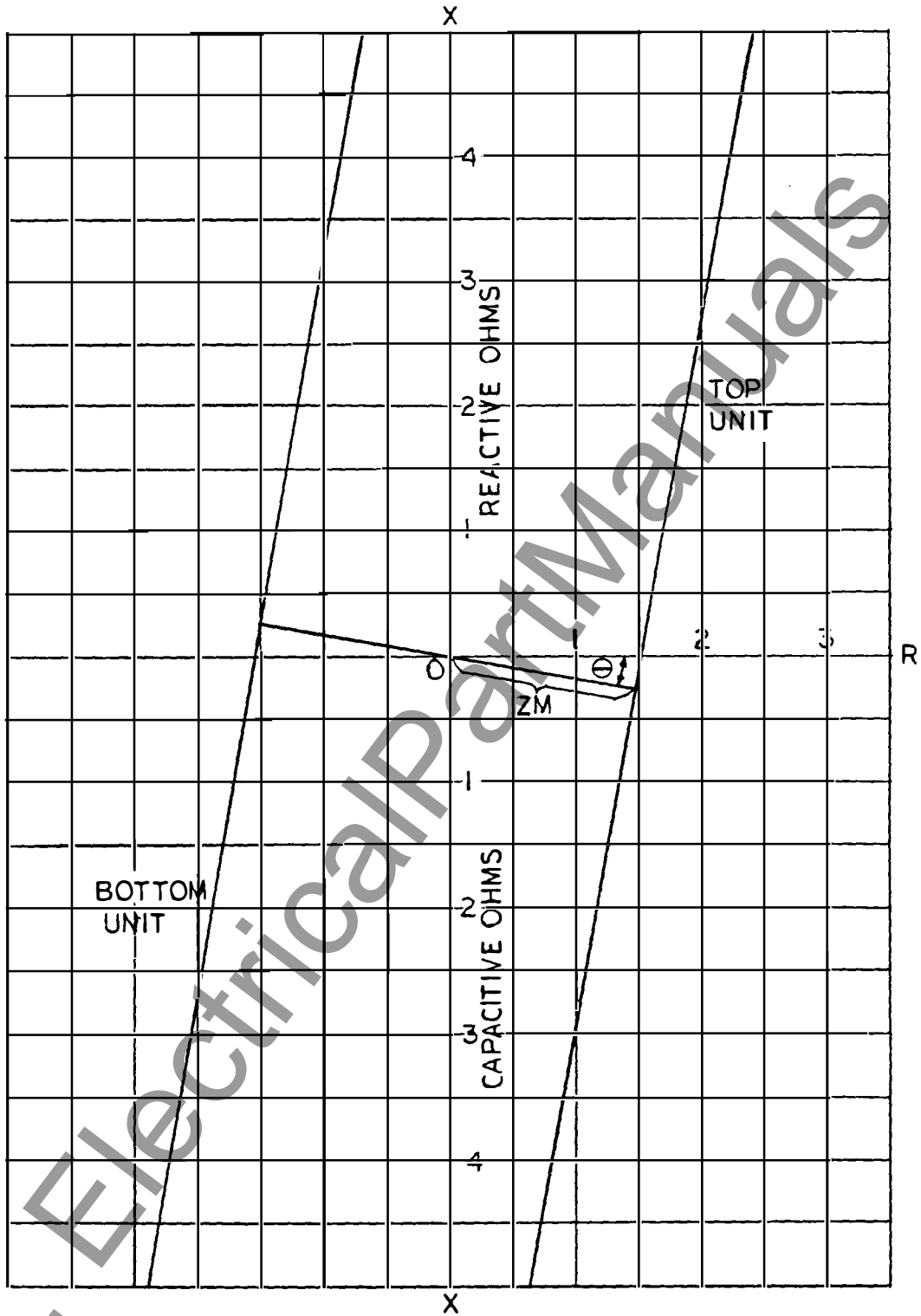
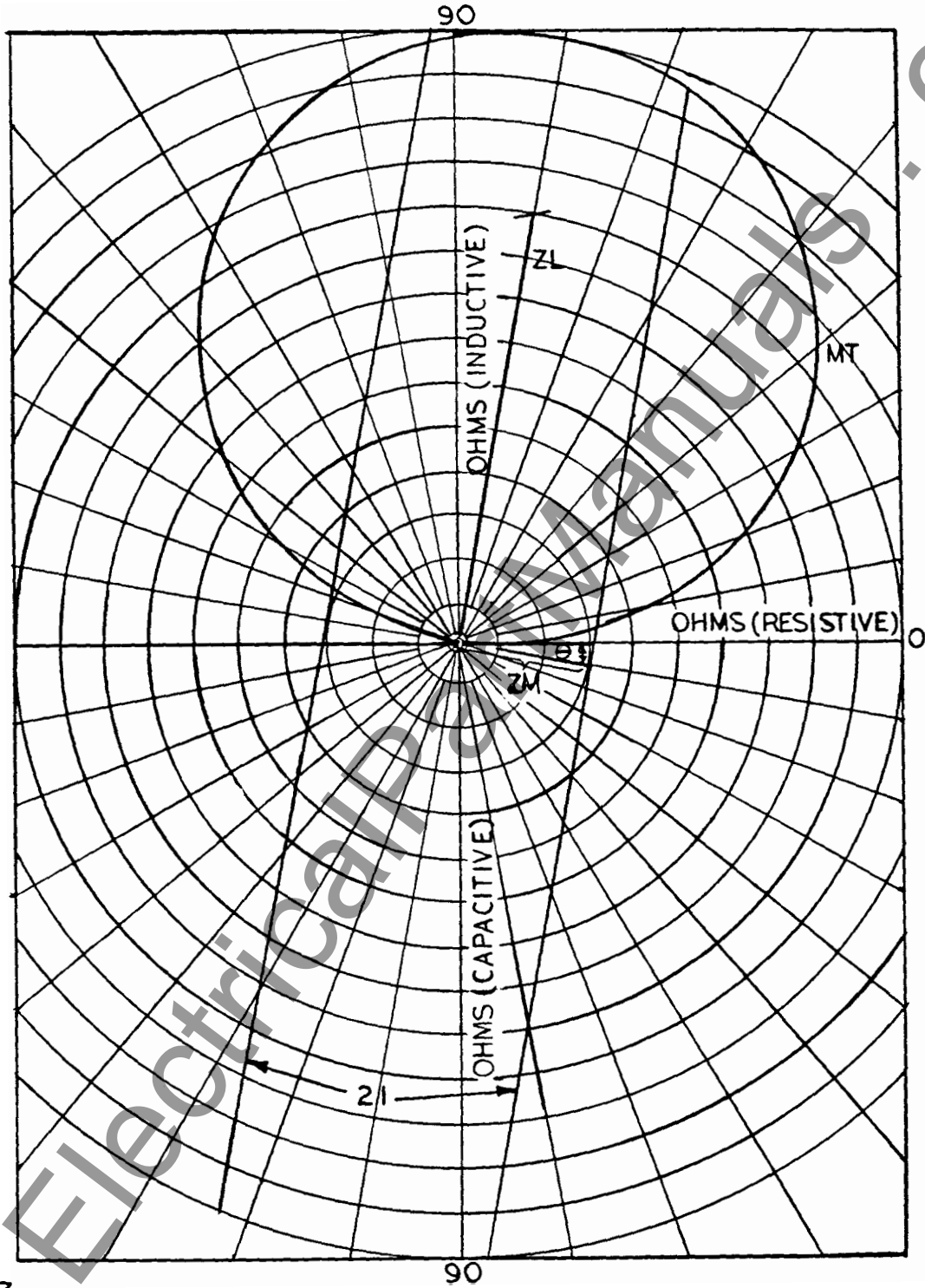

Figure 3 (0269A3051-0) Relay Characteristic on R-X Diagram



ANGLE $I_A - I_B$ LEADS $V_A - V_B$

21-CEX57
ZL-TRANSMISSION LINE
MT-TRIPPING FUNCTION

Figure 4 (0269A3050-0) Relay Characteristic on Polar Diagram

Figure 5 (0108B8983-1) External Connection Diagram for Type CEX57 Relays

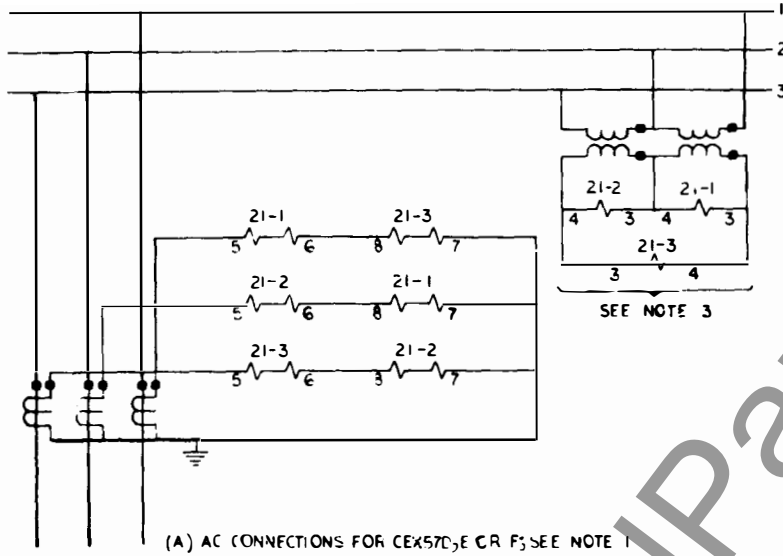

- NOTES:- 1. ONLY ONE CEX57E REQUIRED IN OUT-OF-STEP TRIPPING APPLICATIONS; SELECT ANYONE OF 21-1, 21-2 OR 21-3 AND USE CONNECTIONS SHOWN.
2. SEE APPROPRIATE NAA OR GSY INSTRUCTION BOOK FOR DC CONNECTIONS TO CEX57E RELAY FOR USE IN OUT-OF-STEP TRIPPING APPLICATIONS. REFER TO NEAREST GE DISTRICT SALES OFFICE FOR SPECIFIC DETAILS.
3. JUMPERS ARE REQUIRED BETWEEN CASE STUDS 13-14 AND 15-16 OF EACH CEX RELAY FOR ANGLE-OF-MAXIMUM TORQUE SETTINGS OF 5 TO 25 DEGREES. OMIT JUMPERS FOR ANGLE-OF-MAXIMUM TORQUE GREATER THAN 25 DEGREES. (SEE INSTRUCTION BOOK FOR FURTHER DETAILS)

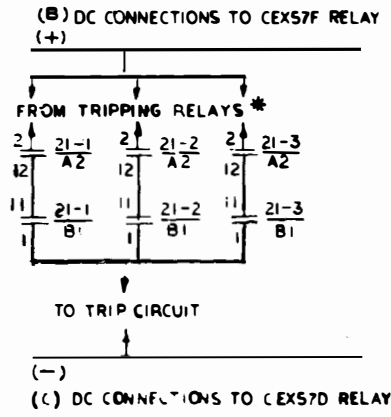
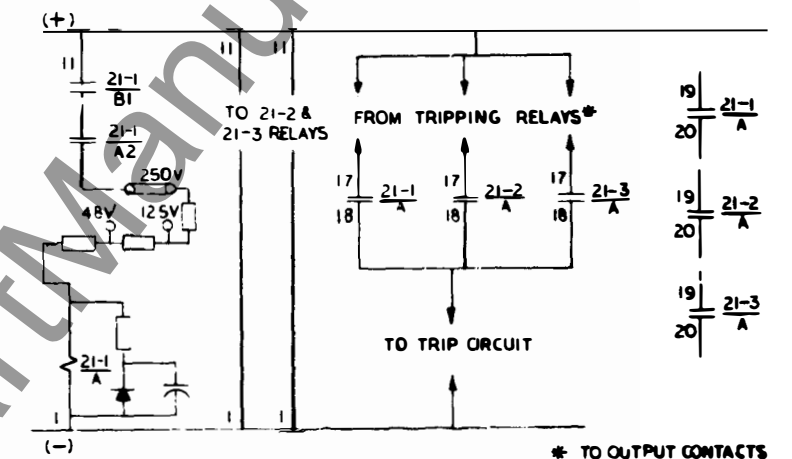

GEK-49778

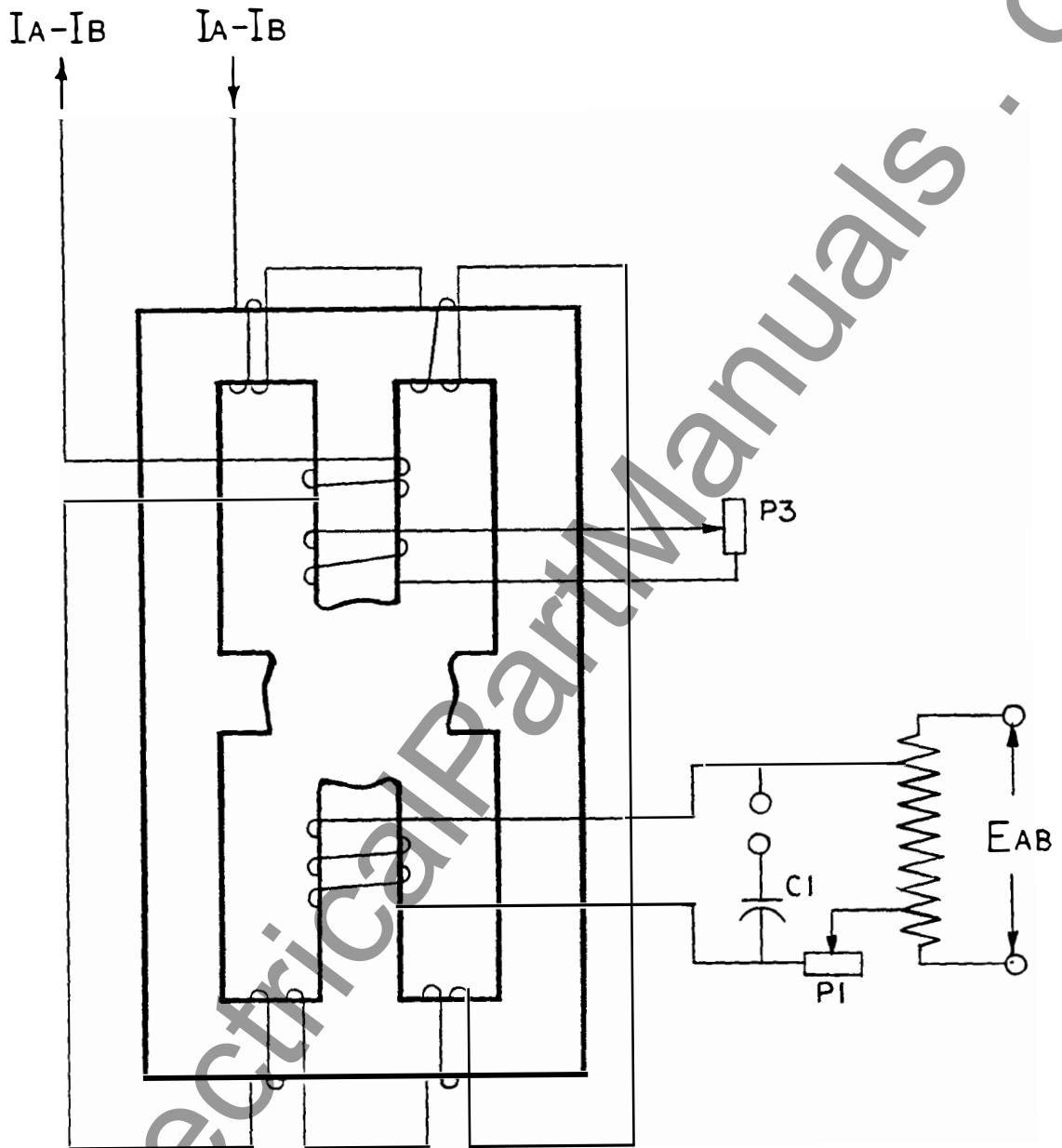

SCHEMATIC OF ANGLE IMPEDANCE UNIT

Figure 6 (0269A3052-0) Schematic of Unit

GEK-49778

- A. INNER STATOR OR CORE
- B. MAGNET & COILS
- C. WAVE WASHERS
- D. OCTAGON NUT FOR CORE ADJUSTMENT
- E. FLAT WASHER
- F. CORE HOLD DOWN NUT (HEXAGON)

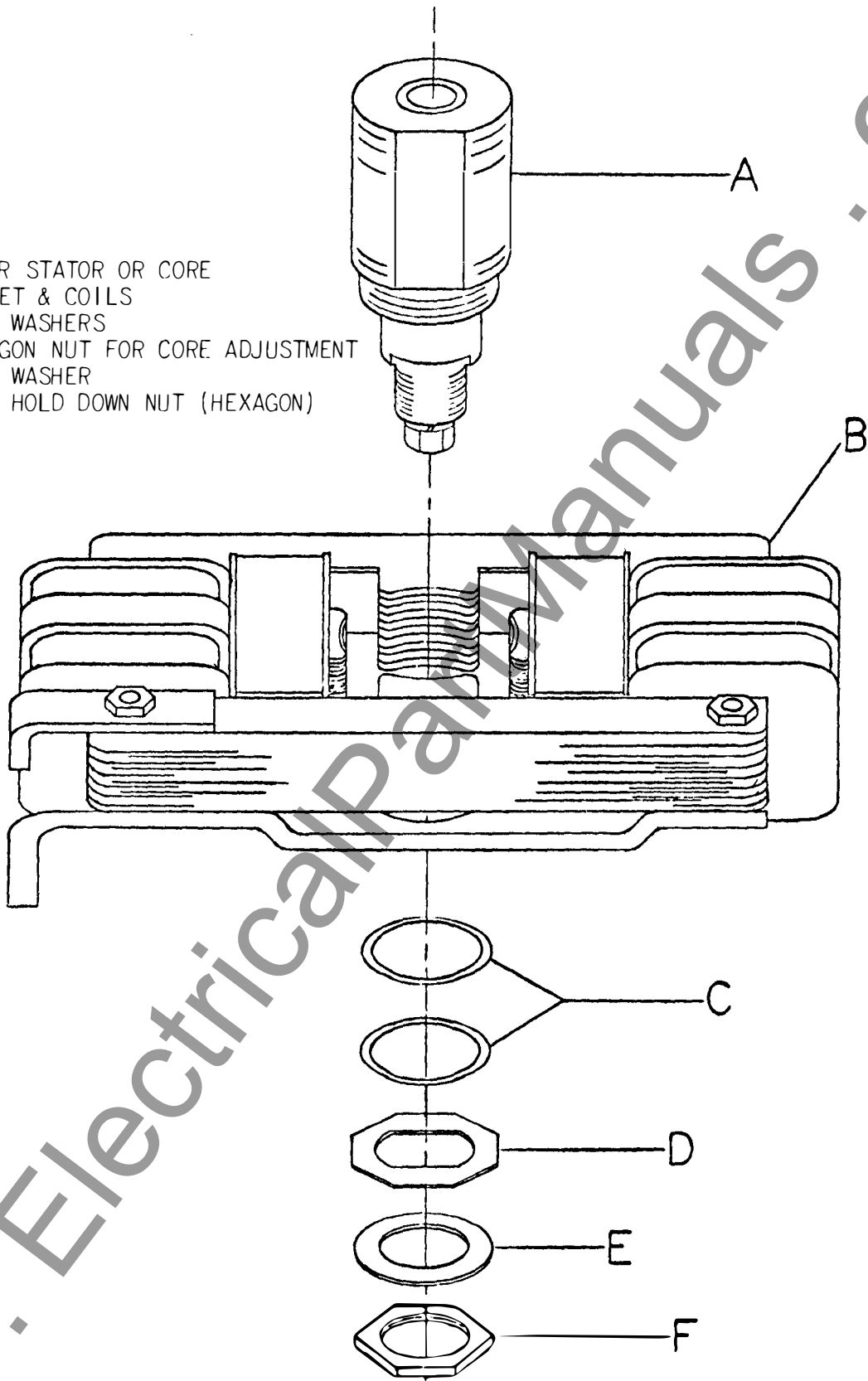
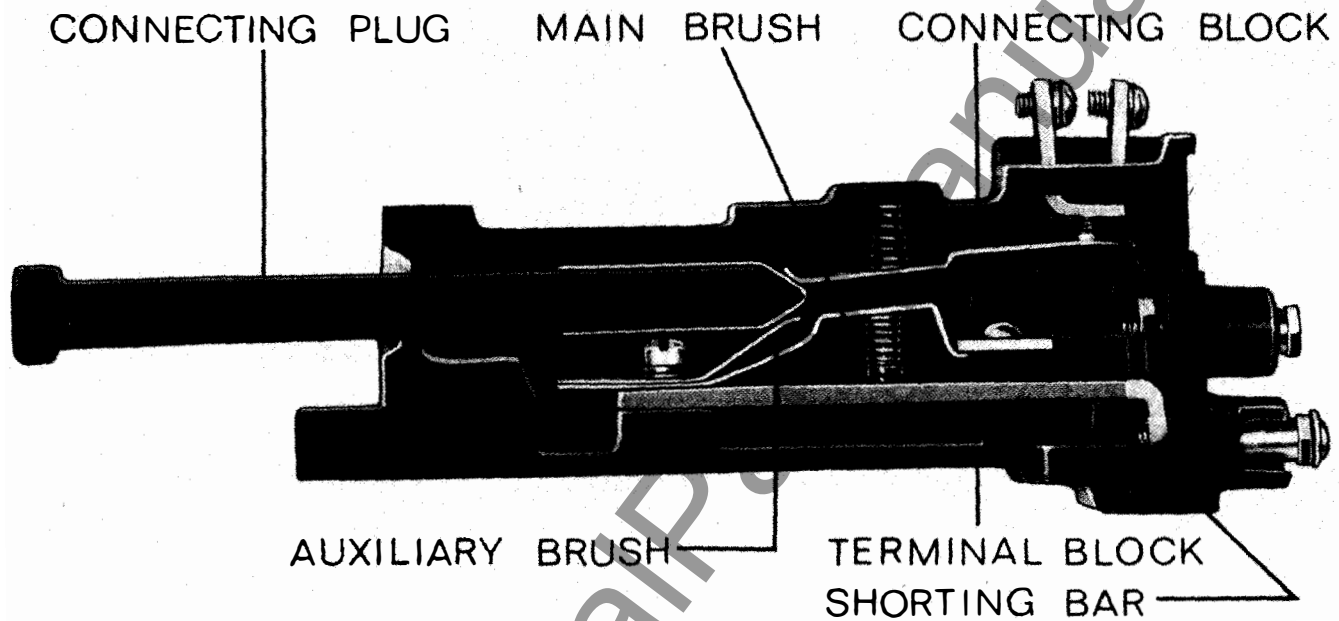
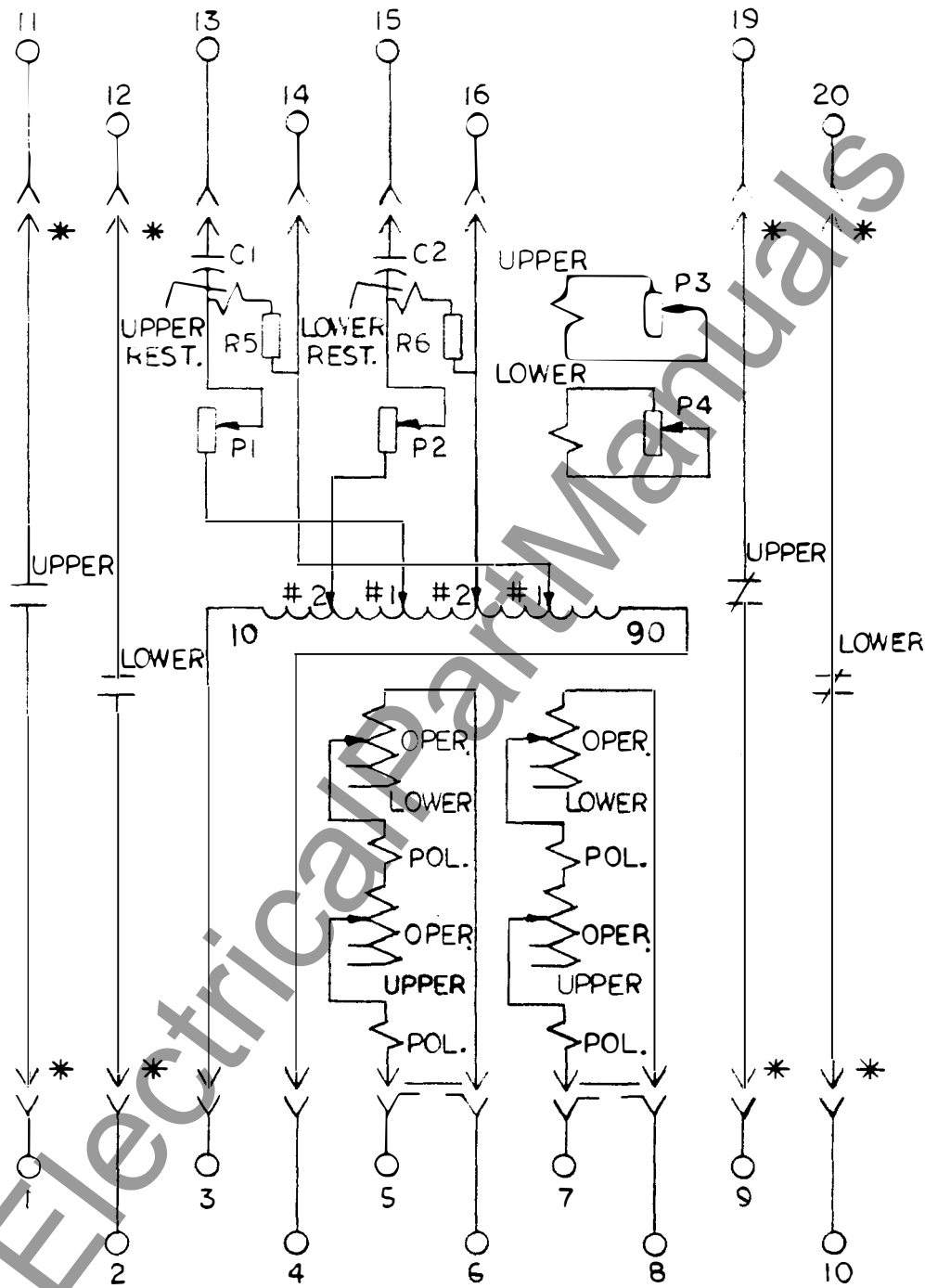

Figure 7 (0208A3583-0) Exploded View of Four-Pole Induction Cylinder Unit



NOTE: AFTER ENGAGING AUXILIARY BRUSH CONNECTING PLUG TRAVELS $\frac{1}{4}$ INCH BEFORE ENGAGING THE MAIN BRUSH ON THE TERMINAL BLOCK

Figure 8 (8025039) Cross-Section of Drawout Case Showing Position of Auxiliary Brush



* = SHORT FINGER

* Figure 9 (0269A3036-2) Internal Connection Diagram for Type CEX57D Relays

* Revised since last issue

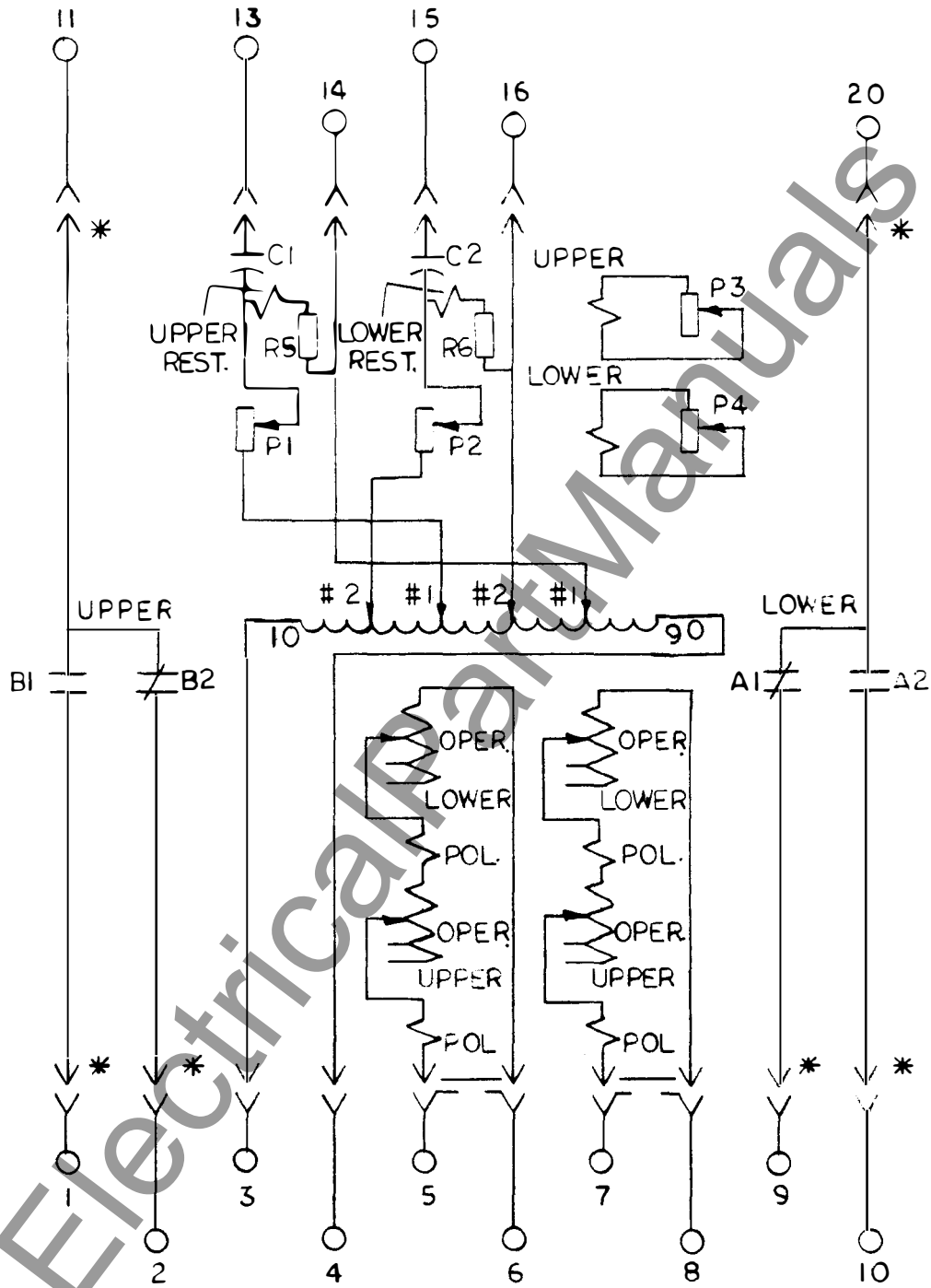

* = SHORT FINGER

* Figure 10 (0269A3037-2) Internal Connection Diagram for Type CEX57E Relays

* Revised since last issue

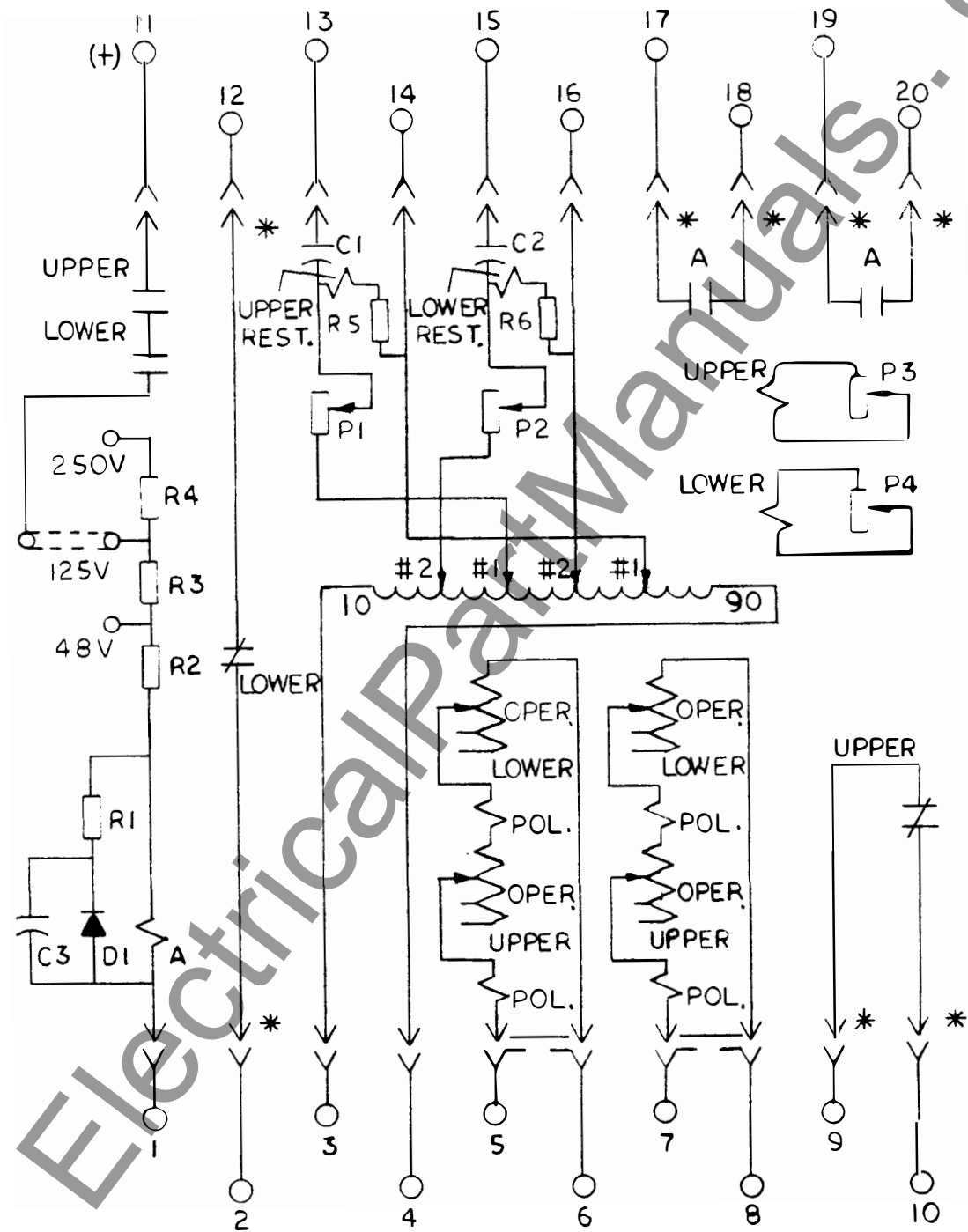

* =SHORT FINGER

* Figure 11 (0269A3038-2) Internal Connection Diagram for Type CEX57F Relays

* Revised since last issue

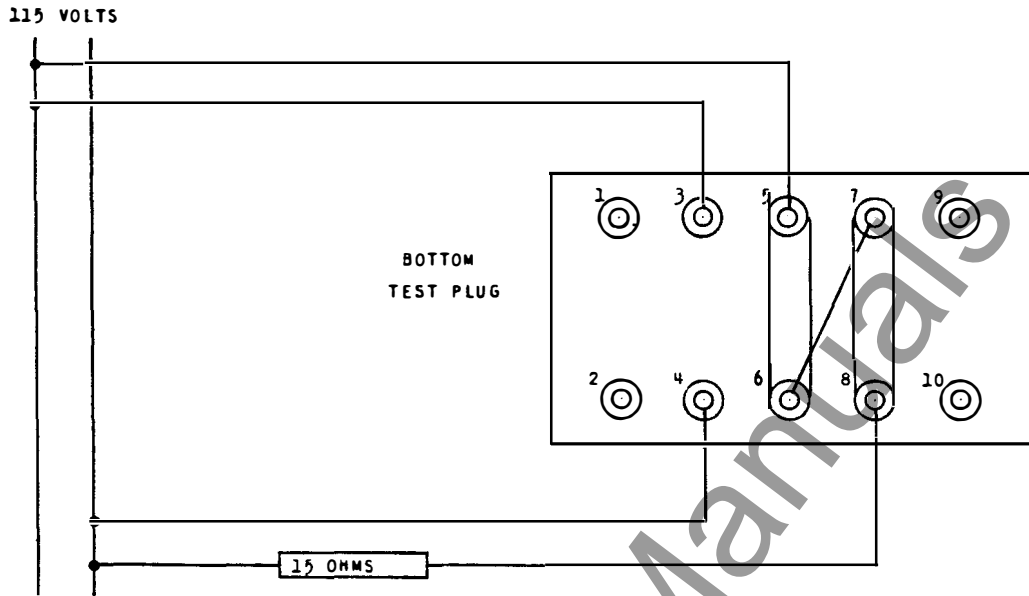

(A) POLARITY CHECK

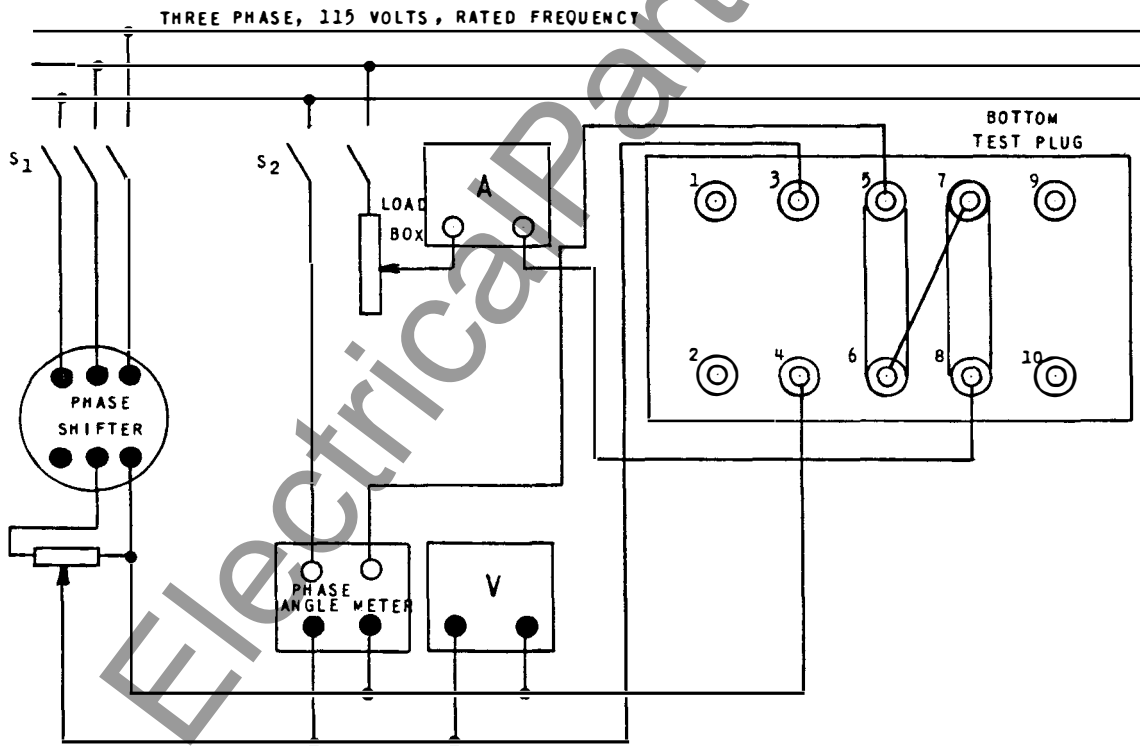

(B) PICK-UP ADJUSTMENT

Figure 12 (K-6556491-1) Test Connections for Type CEX57 Relays

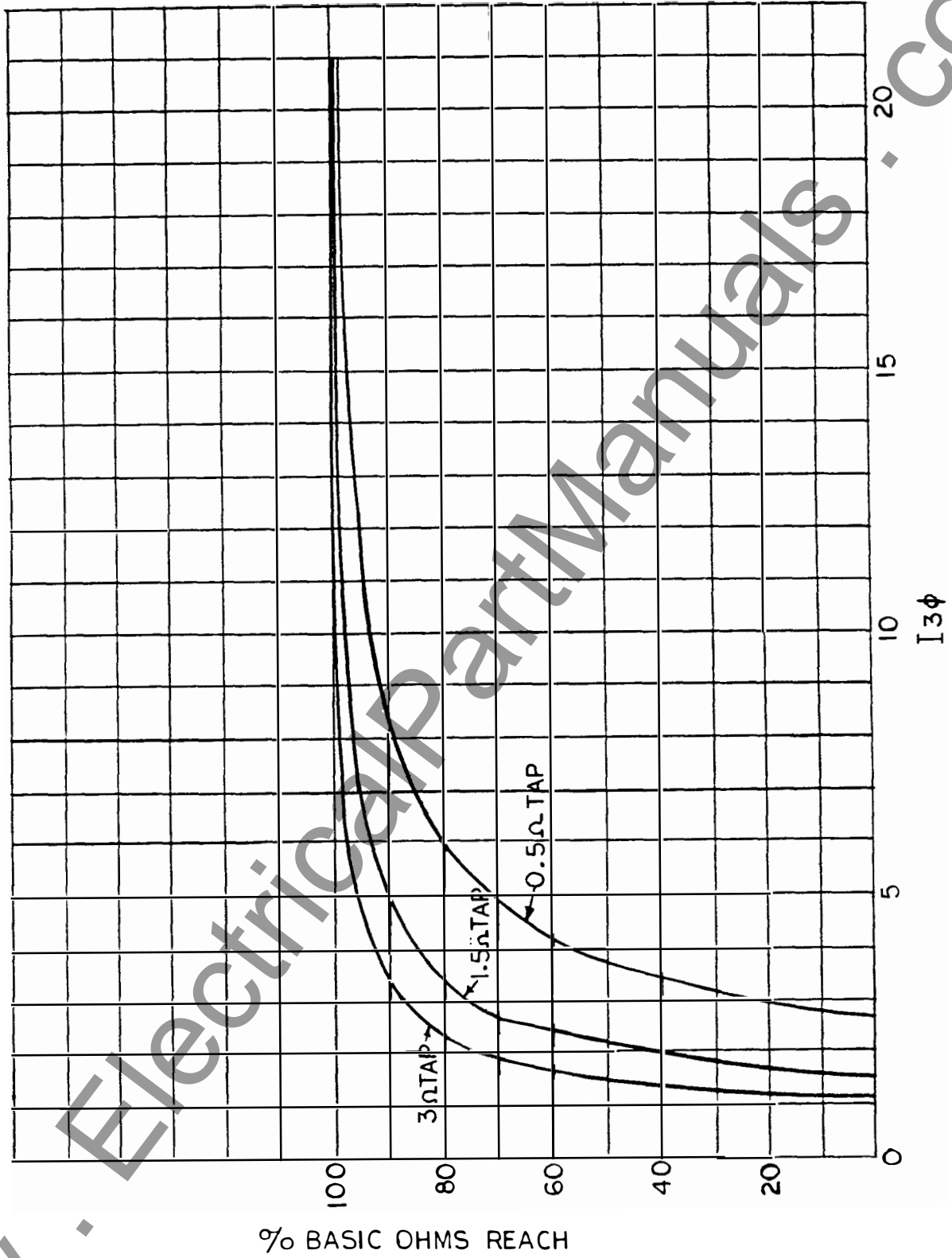
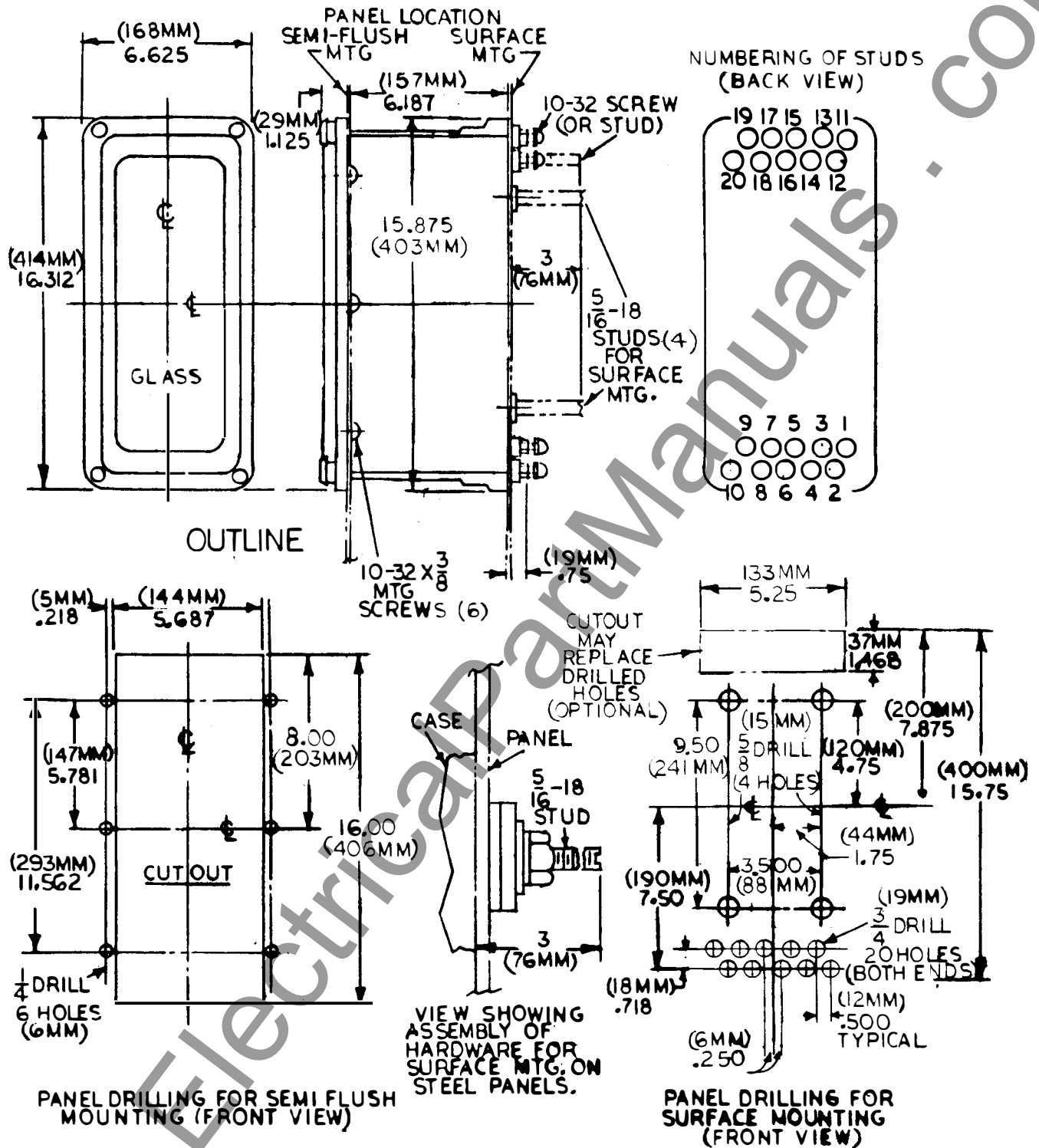

Figure 13 (0269A3053-0) Reach Curve for Type CEX57 Relays



* Figure 14 (K-6209274-4) Outline and Panel Drilling Dimensions for Type CEX57 Relays in M2 Drawout Case

* Revised since last issue