



GEK-86038C

INSTRUCTIONS

TEMPERATURE RELAY

TYPES:

IRT51E
IRT51F
IRT51G
IRT51H

GENERAL ELECTRIC

CONTENTS

	<u>PAGE</u>
DESCRIPTION	3
INTRODUCTION	3
APPLICATION	4
RATINGS	6
BURDENS	8
CONSTRUCTION	9
RECEIVING, HANDLING AND STORAGE	10
INSTALLATION PROCEDURE	10
OPERATING UNIT VOLTAGE CONNECTIONS	11
AUXILIARY CIRCUIT CONNECTIONS	11
RTD CONNECTIONS	13
INSPECTION, ACCEPTANCE TESTS, PERIODIC CHECKS AND ROUTINE MAINTENANCE	14
VISUAL INSPECTION	14
MECHANICAL INSPECTION AND ADJUSTMENTS	15
CONTACT INSPECTION AND CLEANING	16
AUXILIARY BRUSHES	16
RHEOSTAT CLEANING	16
ELECTRICAL TESTS	16
CALIBRATION PROCEDURE	18
RENEWAL PARTS	20
LIST OF TABLES	21
LIST OF ILLUSTRATIONS	22

TEMPERATURE RELAY

TYPES:

IRT51E
IRT51F
IRT51G
IRT51H

DESCRIPTION

INTRODUCTION

The type IRT temperature sensing relays are designed for use with single element three lead, resistance temperature detectors (RTD). Models are available for use with the following specific type RTD:

- a. 10 ohm at 25°C copper RTD
- b. 100 ohm at 0°C platinum RTD
- c. 120 ohm at 0°C nickel RTD

The models are listed in Table 1.

The type IRT relays will provide overtemperature protection, either trip or alarm for any apparatus that is equipped with one of the listed RTDs. The relays are continuously adjustable over a temperature sensing range of 80°C to 165°C.

These relays are of the wattmetric induction disk type and provide various contact combinations as described below. The measuring circuit is similar to a Wheatstone Bridge, except that two adjacent legs of the bridge are replaced by transformer secondary windings. The primary winding of this transformer forms the polarizing coil of the wattmetric unit.

The type IRT51E relay is an overtemperature sensing relay having a single normally-open contact with a target seal-in unit, as shown in Figure 7. The relay is furnished in a single end, small size drawout case.

The IRT51F relay is an overtemperature sensing relay having both normally-open and normally-closed output contacts. These contacts are provided by an auxiliary unit (operating from the main induction disk unit contacts in a pickup, seal-in knock down circuit, as shown in Figure 8. The relay is self-resetting when the detected temperature falls below a preselected level. This reset temperature is continuously adjustable over a range from 50°C to 300°C below the set operating temperature. A manual reset target is included, which is operated by a contact of the auxiliary unit A. The relay is mounted in a single end, small size drawout case.

The type IRT51G is an overtemperature sensing relay providing two normally-open and two normally-closed electrically separate output contacts. These contacts are provided by a two-position latching relay whose operating coil (OP) and reset coil (R) are controlled by the left-hand (IRTL) and right-hand (IRTR) contacts, respectively,

These instructions do not purport to cover all details or variations in equipment nor to provide for every possible contingency to be met in connection with installation, operation or maintenance. Should further information be desired or should particular problems arise which are not covered sufficiently for the purchaser's purposes, the matter should be referred to the General Electric Company.

To the extent required the products described herein meet applicable ANSI, IEEE and NEMA standards; but no such assurance is given with respect to local codes and ordinances because they vary greatly.

www.ElectricalPartManuals.com

the main induction disk unit, as shown in Figure 9. The relay operates to close the normally-open output contacts whenever the detected temperature exceeds the set value. These output contacts can be reset:

- a. manually
- b. electrically
- c. self-reset by means of external connections

but only after the detected temperature has fallen below the reset temperature of the main unit and its right-hand (IRT_R) contact has closed. The reset level of the main unit is continuously adjustable from 50°C to 30°C below its operating temperature level. The IRT51G relay is mounted in a double end, small size drawout case.

The type IRT51H is similar to the IRT51G except an RTD probe assembly is furnished as a part of the relay model. The probe is a three wire, single element, tip sensitive, 100 ohm at 0°C, platinum RTD. The probe comes with a fluid seal installation fitting and also a brass reducing fitting for use where required (see **INSTALLATION PROCEDURE**).

APPLICATION

The type IRT51 relays can be used to protect any apparatus equipped with one of the resistance temperature detectors listed in the INTRODUCTION section. The types IRT51E and IRT51F relays are intended primarily for the protection of motors or generators having the RTD's embedded in the windings. The usable temperature range of 80°C to 165°C makes them particularly suitable for application on machines with class A, B or F insulation. These relays may also be applied to protect power transformers against overheating with associated RTD's placed in strategic locations in the tank.

Typical external connections for the type IRT51E relay are shown in Figure 10. Typical external connections for the type IRT51F relay are shown in Figure 11.

The types IRT51G and IRT51H relays are intended primarily for bearing temperature protection of rotating equipment. Typical external connections for these relays are shown in Figure 12.

The functions that temperature relays perform depend upon the type of equipment to be protected, its importance to the system, and its location in the system. In unattended stations, for example, the IRT51E or IRT51F relays operating from embedded RTD's may be used to reduce or remove load automatically. The type IRT51F with its normally-open (IRT_L) and normally-closed (IRT_R) contacts could also be employed to prevent an increase in load until the temperature has returned to an acceptable level.

In attended stations, the function of these relays is generally to provide a warning alarm that an overtemperature condition exists, especially in the case of major units and essential auxiliary power equipment. In addition to sounding an alarm, the relays may also initiate a timing device which causes a delayed automatic corrective action if the station operator has not responded to the alarm within a reasonable time.

These relays should not be used to determine machine load, since operating temperature is not necessarily a reliable indication of maximum permissible load. Other design limitations may place more stringent restrictions on machine rating.

TABLE 1

RELAY MODEL DESCRIPTION TABLE

RELAY MODEL NUMBER	12IRT51E1A	12IRT51E2A	12IRT51E3A	12IRT51F1A	12IRT51F2A	12IRT51F3A	12IRT51F4A	12IRT51F5A	12IRT51F6A	12IRT51G1A	12IRT51G2A	12IRT51G3A	12IRT51H2A
For use with:													
10 ohm @ 25°C copper RTD	X			X			X			X			
100 ohm @ 0°C platinum RTD		X			X			X			X		X
120 ohm @ 0°C nickel RTD			X			X			X			X	
RTD furnished with relay													X
Adjustable overtemperature range 80°C-160°	X	X	X	X	X	X	X	X	X	X	X	X	X
Adjustable reset temperature 50-30°C below set operating temperature				X	X	X	X	X	X	X	X	X	X
Operating Circuit 120/240 VAC, 50/60 Hz	X	X	X	X	X	X				X	X	X	X
Auxiliary Circuit 120/240 VAC, 50/60 Hz				X	X	X				X	X	X	X
125/250 VDC				X	X	X				X	X	X	X
Target				X	X	X							
Target Seal-in 0.2/2.0 amp DC	X	X	X				X	X	X	X	X	X	X
Reset Features													
Manually	X	X	X							X	X	X	X
Electrically (remote)										X	X	X	X
Self				X	X	X	X	X	X	X	X	X	X
Number of Contacts													
Electrically Separate N.O.	1	1	1	1	1	1	1	1	1	2	2	2	2
Electrically Separate N.C.							1	1	1	2	2	2	2
Convertible N.O. or N.C. contact				1	1	1							
Internal Connections Figure		7			8			8			9		9
Outline and Panel Drilling Figure		17			17			17			18		18
Operative Circuit													
110/220 VAC 50/60 Hz							X	X	X				
Auxiliary Circuit													
110/220 VAC 40/60 Hz													
110/220 VDC							X	X	X				

It is important to note that these type IRT relays detect actual temperature, not rise above ambient. The temperature setting should be made on the basis of long term trends in ambient temperature.

RATINGS

The operating unit of the type IRT relays has a center tapped coil that permits operation at either 120 or 240 volts AC*. For 240 volt operation, the two operating coils must be connected in series. For 120 volt operation, the two operating coils must be connected in parallel. See Figures 10, 11 and 12 for the AC power source connections. The IRT51E and IRT51F models have an internal, insulated standoff post for making the series connection, while the IRT51G and IRT51H models bring all of the operating coil leads to separate terminals external to the relay. The IRT51E and IRT51F models are shipped from the factory connected for 240 volt operation.

* Some models of the IRT51F(-)A relay are rated at 110/220 VAC or DC. See Table I.

The type IRT relays are suitable for operation on 50 hertz and 60 hertz power systems.

The type IRT relays are designed for use with the following specific type resistance temperature detectors:

- a. 10 ohms at 25°C copper RTDs
- b. 100 ohms at 0°C platinum RTDs
- c. 120 ohm at 0°C nickel RTDs

Use only the specific RTD for which the particular model IRT was designed.

The IRT51E, IRT51G and IRT51H relays are furnished with a target and seal-in unit having taps for 0.2 amps DC and 2.0 amps DC operation. Table 2 shows the different ratings based on tap settings.

TABLE 2

TARGET SEAL-IN UNIT RATINGS

TAP		0.2	2.0
Minimum DC operating current	+0% -25%	0.2	2.0
DC resistance	+10% (ohms)	7.0	0.13
Tripping duty	(amps)	5.0	30.0
Carry 30 amps	(seconds)	0.03	4.0
Carry 10 amps	(seconds)	0.25	30.0
Carry continuous	(amps)	0.3	3.0
Contact current closing rating	(amps)	30	30
	(volts Max.)	250	250

The tap setting used on the seal-in units is determined by the current drawn by the trip circuit. The 0.2 amp tap is for use with trip circuits that operate on

currents ranging from 0.2 to 2.0 amps DC at the minimum control voltage. If this tap is used with trip coils requiring more than 2.0 amps, there is a possibility that the 7.0 ohms resistance of the target seal-in unit will reduce the current to such a low value that the breaker will not be tripped.

The 2.0 amp tap should be used with trip coils that take 2.0 amps DC or more at the minimum control voltage. The tripping current should not exceed 30 amps at the maximum control voltage. If the tripping current exceeds 30 amps, an auxiliary relay should be used so the tripping current does not pass through the target seal-in unit.

The IRT51F relay is furnished with a target unit and an auxiliary telephone type relay. The auxiliary circuit may be used with 120 or 240 volts AC, 50 or 60 hertz, or with 125 or 250 volts DC*. A voltage level selection link is located inside of the relay on top of the resistor mounting plate, and is marked "LOW" for 120 and 125 volts, and "HIGH" for 240 and 250 volts. This link must be in the position corresponding to the voltage level being applied. The IRT51F relay is shipped from the factory with the link in the "HIGH" position.

* Some models of the IRT51F(-)A relay are rated at 110/220 VAC or DC. See Table I.

The target shows whenever an overtemperature condition is first sensed. It must be manually reset. The target is not a seal-in type.

The auxiliary telephone-type relay contacts will close and carry 30 amps DC momentarily for tripping duty at control voltages of 250 volts DC or less. These contacts will carry one amp continuously and have an interrupting rating as shown in Table 3.

TABLE 3

AUXILIARY TELEPHONE-TYPE RELAY INTERRUPTING RATINGS

		AMP INDUCTIVE	AMP NON-INDUCTIVE
Volts AC (50/60 hertz)	110	0.80	2.1
	120	0.75	2.0
	220	0.55	1.1
	240	0.50	1.0
Volts DC	48	1.0	3.0
	110	0.5	1.7
	125	0.5	1.5
	220	0.28	0.78
	250	0.25	0.75

The IRT51G is furnished with a target seal-in unit and a latching-type auxiliary telephone relay. See TARGET SEAL-IN UNIT RATINGS, Table 2; and AUXILIARY TELEPHONE TYPE RELAY INTERRUPTING RATINGS, Table 3.

The auxiliary circuit will operate whenever an overtemperature condition is sensed. The relay will not permit the auxiliary circuit to reset until the detected temperature decreases to below a preselected temperature level, and the right-hand (IRTR) contact has closed.

The auxiliary circuit may be reset manually by pushing upward on the reset rod located on the bottom left side of the cover. Or it may be reset electrically from a remote location by connecting a control switch across terminals 19 and 20. Or the relay may be made self-resetting by shorting terminals 19 and 20 together. If either the remote electrical or self-resetting functions are selected, and the relay is reset, the target will remain in view. To remove the target indication, the reset rod must be pushed manually.

The IRT51H is similar to the IRT51G. The difference between these two models is that the IRT51H is furnished with a three wire, single element, tip sensitive, 100 ohms at 0°C, platinum RTD assembly. The RTD assembly comes with a special brass reducing fitting that will permit replacement of existing General Electric temperature relays, Type TBB, having syphon bulbs and capillaries, with an IRT51H. See Figure 4, RTD Assembly.

BURDENS

Table 4 shows the burdens for the operating units of the type IRT relays based upon the type of RTD for which the unit is designed.

TABLE 4
OPERATING UNIT BURDENS

RTD DESCRIPTION			VOLTS*	FREQUENCY	MILLIAMPS	VOLT-AMPS	WATTS
OHMS	°C	MATERIAL					
10	25	copper	120	60	63.5	7.62	2.61
			240	60	31.7	7.61	2.60
			120	50	73.1	8.77	2.71
			240	50	36.5	8.76	2.71
100	0	platinum	120	60	65.4	7.80	2.67
			240	60	32.8	7.87	2.69
			120	50	75.3	9.04	2.79
			240	50	37.8	9.07	2.80
120	0	nickel	120	60	68.1	8.17	2.79
			240	60	34.0	8.16	2.79
			120	50	78.4	9.41	2.91
			240	50	39.2	9.41	2.91

* The milliamperes for the 110/220 volt operation are approximately 92% of the values shown in Table 4. The volt-amperes and watts are reduced to approximately 84% of the values shown in Table 4.

Tables 5, 6 and 7 show the burden data for the auxiliary circuits of the IRT relays. The IRT51F, IRT51G and IRT51H relays do not have a single burden, rather the burden changes as the relay auxiliary circuit changes its state from reset to picked up. Tables 6 and 7 reflect the transitional and steady state burdens of the auxiliary circuits.

TABLE 5

BURDEN FOR IRT51E

TARGET SEAL-IN UNIT	
TAP	OHMS
0.2	7.0
2.0	0.13

TABLE 6

BURDEN FOR IRT51F

VOLTS	FREQUENCY	AUXILIARY CIRCUIT STATE		
		PICKED UP		NOT PICKED UP (OHMS)
		MOMENTARY	CONTINUOUS	
110	50/60	780 ohms	2650 ohms	infinite
120	50/50	850 ohms	2900 ohms	infinite
220	50/60	3530 ohms	5400 ohms	infinite
240	50/60	3850 ohms	5900 ohms	infinite
110	DC	750 ohms	2550 ohms	infinite
125	DC	850 ohms	2900 ohms	infinite
220	DC	3850 ohms	5200 ohms	infinite
250	DC	3850 ohms	5900 ohms	infinite

TABLE 7

BURDEN FOR IRT51G AND IRT51GH

TARGET SEAL-IN UNIT		AUXILIARY CIRCUIT			
TAP	OHMS	VOLTS	FREQ.	DURING	
				TRANSITION	STEADY-STATE
0.2 2.0	7.0 0.13	110	50/60	1830 ohms	infinite ohms
		120	50/60	2000 ohms	infinite ohms
		220	50/60	3700 ohms	infinite ohms
		240	50/60	4000 ohms	infinite ohms
		110	DC	1760 ohms	infinite ohms
		125	DC	2000 ohms	infinite ohms
		220	DC	3520 ohms	infinite ohms
		250	DC	4000 ohms	infinite ohms

CONSTRUCTION

The relay case is suitable for either surface or semi-flush panel mounting. Hardware is provided with the relay for either mounting method. The cover attaches to the case with four cover screws which have provisions for a sealing wire. The cover also has the reset mechanism for target reset. On the IRT51G and IRT51H, this reset mechanism is used to manually reset the relay. Care must be taken when removing or replacing the cover on the case because of the mechanical interaction between the reset mechanism and the individual internal components of the relay. Forcing the cover on or off may damage the reset mechanism system.

The back of the case has studs mounted in an outer block. These studs are used for making the external wiring connections to the relay case. A removable connection plug connects the outer block to an inner block which is connected to the internal wiring of the relay. Both the outer and inner blocks have spring-backed contact fingers to assure good electrical contact with the connection plug.

The relay mechanism is mounted in a steel framework called a cradle and is a complete unit with all leads being terminated at the inner block. The cradle is held securely in the case with a latch at the top and the bottom and by a guide pin at the back of the case. The case and cradle design prevents inserting the relay into the case upside down. The connection plug, besides making electrical connections, also locks the latch in place. The cover, in turn, holds the connection plug in place.

To draw out the relay unit from the case, first carefully remove the cover, then the connection plugs. Shorting bars are built into the relay case to short the current transformer circuits. Release the latches. The relay unit may now be removed from the case by pulling on the cradle. To replace the relay unit, follow the reverse order. Use care when placing the cover back on to the relay case to avoid damaging the reset mechanism.

RECEIVING, HANDLING AND STORAGE

These relays, when not included as part of a control panel, are shipped in cartons designed to protect them against damage. Immediately upon receipt of a relay, examine it for any damage sustained in transit. If damage due to rough handling is evident, file a damage claim at once with the transportation company and promptly notify the nearest General Electric Apparatus Sales Office.

Exercise care when handling or unpacking the relay, to avoid disturbing adjustments or damaging the relay.

Perform an inspection and an acceptance test as soon as the relay is received to make sure that no damage was sustained during shipment and that the relay calibrations have not been disturbed.

If the relays are not to be installed immediately, they should be stored in their original cartons in a place that is free from moisture, dust and metallic particles. Foreign matter collected on the outside of the case may find its way to the inside of the case when the cover is removed, creating the possibility of relay misoperation.

INSTALLATION

The location should be clean and dry, free from dust and vibration, and well lighted to facilitate inspection and testing.

The relay should be mounted on a vertical surface. The outline and panel drilling drawings are shown in Figures 17 and 18.

The RTD assembly furnished as part of the IRT51H relays is shown in Figure 4. The RTD probe is tip sensitive; therefore, the probe tip must come in direct contact with the material whose temperature is to be sensed. The temperature probe is not spring loaded; therefore, its primary application is for sensing the temperature of fluids.

The one-half to three-eighths inch brass reducing bushing pipe fitting shown in the RTD assembly (Figure 4) is furnished as part of the RTD assembly. It is not necessary to use this fitting when applying the RTD assembly to new equipment. The primary reason this fitting is furnished is to readily adapt the RTD assembly to applications which already have a temperature sensing element installed. This fitting will adapt the RTD assembly to take the place of the siphon tube, bulb and packing gland of the General Electric Company temperature relay type TBB.

OPERATING UNIT VOLTAGE CONNECTIONS

The IRT51 relays may be used with an operating voltage of 110/120 volts AC or 220/240 volts AC at frequencies of 50 or 60 hertz. A simple change in the wiring scheme to the operating unit is required to operate at either of the two different voltage levels. When the relay is shipped from the factory, it is set for 220/240 VAC operation. Refer to the external connections diagrams shown in Figures 10, 11 and 12 for the connections to be used for different voltage sources.

See Table 1 for the relay voltage ratings.

120 volt AC Operation: Coil H1-H2 must be placed in parallel with coil H3-H4. To make the parallel connection, connect lead H1 to lead H3, and lead H2 to lead H4. Polarity is important.

240 volt AC Operation: Coil H1-H2 must be placed in series with coil H3-H4. To make this connection, connect lead H2 to H3. Polarity is important.

The IRT51E and IRT51F models have an internal insulated standoff post at terminal 8A to assist in making the series connection for 240 volt AC operation. The IRT51G and IRT51H models have the coil leads brought to individual terminals; therefore, the terminal connections must be made external to the relay.

AUXILIARY CIRCUIT CONNECTIONS

IRT51E:

For trip circuits operating on currents ranging from 0.2 to 2.0 amps DC at the minimum control voltage, set the target and seal-in tap screw in the 0.2 amp tap. For trip circuits operating on currents ranging from 2 to 30 amps DC at the minimum control voltage, place the tap screw in the 2.0 amp tap.

The tap screw is the screw holding the right stationary contact of the target seal-in unit. To change tap settings, it is important that the stationary contact positions not be disturbed. A tap changing procedure that will prevent the stationary contacts from getting out of adjustment is as follows:

1. Remove the connection plug.
2. Remove one of the screws in the left stationary contact and place it in the desired tap.

3. Remove the screw from the other tap and place it in the left stationary contact.

During relay operation, tap screws should not be in both taps at the same time. If they are, pickup will occur at the higher tap value. The relays are shipped with the tap screw in the 2.0 amp tap.

IRT51F:

The auxiliary circuit for the IRT51F may be used with 120 or 240 volts AC, 50 or 60 hertz; or with 125 or 250 volt DC*. The only adjustment that must be made to accommodate these different power supplies is the position of a voltage level selection link which is located internally to the relay and may be easily seen when viewing the top of the relay unit when the relay is removed from its case.

The voltage level selection link is labeled "LOW" and "HIGH." The "LOW" position is to be used for 120/125 volts*. The "HIGH" position is to be used for 240/250 volts*. The voltage level selection link position can be changed by loosening the thumb screws and repositioning the link in the desired position. The link should not be permitted to connect the "LOW" and "HIGH" positions together. If this is done, the auxiliary circuit will be disabled and will not operate.

The IRT51F relay also has a set of convertible contacts on terminals 9 and 10. If a normally-closed contact is desired, connect the green lead to terminal 9. If a normally-open contact is desired, the green lead should be connected to terminal 10.

There is a shorting bar between terminals 9 and 10. This shorting bar is used to protect current transformer circuits from being opened whenever the relay connection plug is removed. This shorting bar may be removed if it is not used.

* Some models of IRT51F(-)A relays are rated at 110/220 VAC or DC. See Table 1.

IRT51G and IRT51H:

The auxiliary circuit for the IRT51G and IRT51H relays is the most versatile of all of the IRT auxiliary circuits. It may be used with 120 or 240 volts AC, 50 or 60 hertz; or with 125 or 250 volts DC.

If 120 or 125 volts is to be used, apply power to terminals 1 and 2. If a higher voltage (240 or 250 volts) is to be used, apply power to terminals 1 and 3.

The IRT51G and IRT51H relays have a 0.2/2.0 amp DC target seal-in unit that is used in a circuit with a normally-open contact which will close when an overtemperature condition is sensed. For complete information on the target seal-in unit, see the discussion in the Auxiliary Circuit Connections section for IRT51E.

There are two normally-open and two normally-closed, electrically separate contacts in the auxiliary circuit. One of the normally-open contacts is used in conjunction with a target seal-in unit. The contact states change when an overtemperature condition is first sensed. They will stay in this new state until two conditions are met:

www.ElectricalPartManuals.com

1. The relay senses a temperature at or below the pre-selected reset temperature, causing the right-hand contact (IR_{TR}) to close, and
2. The relay is reset by any one of the three methods listed below:

METHOD 1:

Reset can be accomplished by pushing upward on the reset rod located at the bottom, left side of the relay cover.

METHOD 2:

Reset can be accomplished electrically from a remote location by connecting a switch across terminals 19 and 20. When the switch is closed, the relay will reset; however, the target of the target seal-in unit will still show if the target seal-in unit had operated. The only way to remove the target indication is by manually pushing upward on the reset rod located at the bottom, left side of the relay cover.

METHOD 3:

The relay can be made to be self-resetting by shorting terminals 19 and 20 together. If this method of resetting is chosen, the target of the target seal-in unit will still show if the target seal-in unit had operated. The only way to remove the target indication is by manually pushing upward on the reset rod located at the bottom, left side of the relay cover.

The IRT51G and IRT51H auxiliary circuits have a special interlock arrangement that will maintain the last energized position of the contacts. This position will be maintained even if power is removed from the relay. This special feature must be considered when first placing the relay into service or when returning a relay back into service after completing maintenance on the relay. To avoid tripping on start up for reasons other than overtemperature:

1. Apply power to the IRT relay
2. Reset the IRT relay manually
3. Energize the equipment which is to be protected.

This will ensure that the relay contacts and target seal-in unit are in the correct state for overtemperature protection.

RTD CONNECTIONS

Each of the IRT relays has been designed to be used with a specific type resistance temperature detector. Before connecting an RTD to the relay, make sure that the relay is suitable for use with the RTD. This information is presented on the relay nameplate, and in Table 1 of this instruction book.

The RTDs to be used with IRT relays should be a three wire type. The leads coming from the RTDs should be shielded to prevent stray fields from inducing voltages into the RTD circuit. If an extension to the RTD length is required, the extension leads should be twisted together. Also, the lead extension resistance

* should be identical for all three leads. The resistance of each lead to relays used with 10 ohm RTDs must not exceed 0.25 ohm (1.0 ohm to relays used with 100 ohm or 120 ohm RTDs). A decrease in the operating point of the relay of up to 0.8°C can be expected for each ohm of lead run to relays with 10 ohm RTDs. (The decrease can be up to 0.2°C for each ohm of lead run to relays using 100 ohm or 120 ohm RTDs.)

TABLE 8

LEAD WIRE RESISTANCE

AWG NO.	LEAD WIRE SIZE	OHMS/FT AT 25° C
	DIAMETER INCHES	
12	0.0808	0.0016
14	0.0640	0.0026
16	0.0508	0.0041
18	0.0403	0.0065
20	0.0320	0.0104
22	0.0253	0.0165
24	0.0201	0.0262
26	0.0159	0.0416
28	0.0126	0.0666
30	0.0100	0.1058

Should it become necessary to switch the relay from one RTD to another by a switching scheme, arrange the switching circuit to remove the lead from stud 6 first and restore it last. This procedure will avoid nuisance tripping during the switching operation.

At the time of installation, visually check the relay for tarnished contacts, loose screws, foreign matter within the case, or any other physical imperfections. If any of these are found, they should be corrected immediately.

INSPECTION, ACCEPTANCE TESTS, PERIODIC CHECKS AND ROUTINE MAINTENANCE

Immediately upon receipt of the relay, it should be inspected and tested to make sure that no damage has been sustained in shipment and that the relay calibrations have not been disturbed. Also, in view of the vital role of protective relays in the operation of a power system, it is important that a periodic test program be followed. The interval between periodic checks will vary depending upon environment, type of relay and the user's experience with periodic testing. Until the user has accumulated enough experience to select the test interval best suited to his individual requirements, it is suggested that the following inspections and tests be performed at the time the relay is received, and then repeated once a year thereafter.

VISUAL INSPECTION

Remove the relay from its case and check that there are no broken or cracked parts or any other indications of damage. Check that the internal parts of the relay are clean and that there is no foreign matter within the relay.

* Revised since last issue

MECHANICAL INSPECTION AND ADJUSTMENTSMoving Contact Assembly

1. There should be no noticeable friction when the disk is slowly rotated clockwise. The disk should return by itself to its rest position against the right stationary contact or moving contact stop. If a tendency to bind or excessive friction is evident, check for obstructions to the disk travel. Dirt and metallic particles in the drive magnet unit or drag magnet air gaps can interfere with the disk motion.
2. The disk shaft should have a vertical end play of 1/64 inch to 1/32 inch. The disk does not have to be in the exact center of either the drive magnet or the drag magnet air gaps for the relay to perform correctly. Should the disk not clear all of the air gaps, or if the end play is not 1/64 to 1/32 of an inch, perform the following adjustment:

End play and disk position is determined by the relative positions of the lower jewel bearing and the upper pivot. Both the bearing and the pivot are held in position by set screws in the die-cast supporting frame. The lower jewel is to be located so the disk is approximately centered in the air gaps of the drive magnet and the drag magnet. The upper pivot should then be located so the shaft has 1/64 to 1/32 inch end play. Both set screws must be securely tightened after the adjustment is complete.

3. The contacts should have approximately 1/32 inch wipe. That is, the stationary contact tip should be deflected about 1/32 inch when the disk and moving contact complete their travel. The contact wipe on the left stationary contact is adjusted by turning the screws in the contact brush, which regulates the position of the brush relative to the brush stop.

The leaf spring on the stop arm of the IRT51E and the right side stationary contact on the IRT51F, IRT51G and IRT51H models also have approximately 1/32 inch wipe. This wipe can be adjusted by carefully bending the flexible arm on the stop arm or stationary contact.

Target and Seal-in Units

1. The moving contact assembly should move freely when operated by hand.
2. Both contacts should close at the same time. The cross member of the "T" spring should be in a horizontal plane.
3. The contact wipe should be at least 1/64 inch. This can be checked by inserting a 0.010 inch feeler gage between the armature and the pole piece. The contacts should be closed with the 0.010 inch feeler gage in place.

Telephone Relay Unit

1. With the unit de-energized, each normally-open contact should have a gap of 0.010 to 0.015 inch.

2. The wipe on each normally-open contact should be approximately 0.005 inch. This gap can be checked by inserting a 0.005 inch feeler gage between the armature and the pole piece and operating the armature by hand. The normally-open contacts should make with the 0.005 inch feeler gage in place.
3. The contact pressure should not be less than ten grams, measured at the contact tips.
4. Check for roughness or binding on the interlocking arms on the latching telephone relay unit on the IRT51G and IRT51H models. Use a fine file to dress the interlocking arms only if binding or roughness is observed.

CONTACT INSPECTION AND CLEANING

1. All contacts should meet in alignment.
2. Check for contact condition. If tarnishing or mild pitting is observed, the contacts should be reconditioned with a flexible burnishing tool. A burnishing tool is a flexible strip of metal with an etched-roughened surface, resembling a superfine file. The polishing action is delicate so that no scratches are left, yet corrosion and mild pitting are cleaned thoroughly and quickly. Its flexibility assures the cleaning of the actual points of contact. Do not use a knife edge, file, abrasive paper or cloth to clean relay contacts.

AUXILIARY BRUSHES

CAUTION

Every circuit in the IRT51 drawout case has an auxiliary brush. It is especially important on current circuits and other circuits with shorting bars that the auxiliary brush be bent high enough to engage the connecting plug or test plug before the main brushes do. This will prevent the current transformer secondary circuits from being opened or the current circuits from being interrupted.

RHEOSTAT CLEANING

Although the sliding contact in the temperature selection rheostat is resistant to tarnishing, it is not immune to tarnishing and should be cleaned as part of the normal relay maintenance program. Turning the temperature dial back and forth several times will mechanically clean the slider tip contact within the rheostat and will usually be adequate. If a more thorough cleaning is required, a good quality liquid contact cleaner can be used.

ELECTRICAL TESTS

All alternating current operating devices are affected by frequency. Since non-sinusoidal waveforms can be analyzed as a fundamental frequency plus harmonics of the fundamental frequency, it follows that alternating current devices, such as the IRT type relays, will be affected by the applied waveform. The purity of the sine wave, that is its freedom from harmonics, cannot be expressed as a finite number for any particular relay. Therefore to test alternating current relays, it is essential to use a sine wave of current or voltage of the correct frequency and good wave form.

Relays to be used with direct current power should be tested using a good direct current power supply, not full wave rectified power. Unless the rectified power supply is well filtered, that is, there is less than 5% ripple, the IRT auxiliary circuits may behave slightly different when tested with a power supply that is substantially different than the system power supply.

Since all type IRT relays that are in service operate in their case, they should be tested in their case or an equivalent steel case. In this way, any magnetic effects of the enclosure will be duplicated during testing.

Before testing is begun, check that the relay is level and in a vibration-free environment. In addition, the relay should have the cover on and power applied at rated voltage and frequency to the operating circuit for approximately 30 minutes prior to actual temperature point testing. During the 30 minute warm up period, there should be a simulated RTD load on terminals 4, 5 and 6.

Selection of Simulated RTD Load

- * To choose the value of this simulated RTD load, select the temperature at which relay operation is desired. The relay is calibrated in degrees centigrade. Figure 16 may be used to convert Fahrenheit to Centigrade if temperature is known in Fahrenheit. Go to Figure 13, 14, or 15, depending upon the type of RTD for which the IRT relay has been designed (10 ohms at 25°C copper, 100 ohms @ 0°C platinum, or 120 ohms @ 0°C nickel). Select a resistor value equal to the simulated RTD load resistance associated with the desired operating temperature. This is the resistance to be used as the simulated RTD load. Measure the resistance of the resistor very carefully, since a small difference in resistance values can mean several degrees difference between what is desired and what is actually obtained.

During the 30 minute warm up period, set a temperature on the temperature selection dial just over the temperature associated with the simulated RTD load. The relay should not close the IRT_L (overtemperature) contact.

Apply power at rated voltage and frequency to the auxiliary circuits.

After the 30 minute warm up period, adjust the temperature selection dial to the temperature associated with the resistance of the simulated RTD load. The relay overtemperature contact (IRT_L) should close within 2° of the relay setting. If it does not, see the CALIBRATION PROCEDURE section.

The IRT51F, IRT51G and IRT51H relays have a reset temperature contact (IRT_R). When the relays are shipped from the factory, the reset temperature is adjusted to 100C below the temperature dial selection temperature. To change this reset temperature, the contact gap distance must be changed by loosening the locking screws of the low temperature contact dial, and turning the dial. Turn the dial counterclockwise (opening the contact gap) to decrease the reset temperature, or turn it clockwise (closing the contact gap) to raise the reset temperature. Tighten the locking screws after adjusting the contact gap. To check the reset temperature setting, choose a simulated RTD resistance that corresponds to the desired reset temperature. The IRT_R (reset) contact should close within 2° of the desired reset temperature.

- * Revised since last issue

Check that the auxiliary circuits function as designed and that the reset mechanisms function properly.

CALIBRATION PROCEDURE

The IRT relays have been calibrated at the factory and the calibration settings should not require any additional adjustment. Recalibration should be considered only after all of the checks, tests and servicing notes, including cleaning the temperature selection dial rheostat, have been accomplished. If the relay still shows that it is out of calibration after the tests, checks and service listed in the **INSPECTION, ACCEPTANCE TESTS, PERIODIC CHECKS AND ROUTINE MAINTENANCE** section of this instruction book have been completed, proceed as follows:

1. Remove all windup from the induction disk spring so that the moving contact in the relaxed position just makes contact with the left stationary contact.
2. Wind the spring counterclockwise 90°. The ring may be turned by inserting a screwdriver in the notches around the edge. The notches are spaced at about 30° increments. This windup will cause the moving contact to touch the right stationary contact or the moving contact stop.
3. Set the adjustable tap (slide band) on R2 to a position at the center of the adjustable range of the resistor.
4. Using AWG No. 12 or larger diameter wire, with a maximum wire length of 12 inches, connect resistor A from Table 9 across terminals 4 and 5. Short terminals 5 and 6 together.
5. Turn the temperature selection dial to the 160°C setting.
6. Apply rated voltage and frequency to the operating circuit.
7. Adjust R1 until the moving contact just makes the left IRT stationary contact (IRT_L). Tighten the slide band in this position. If the R1 sliding tap does not permit this setting precisely, adjust the spring windup until this setting is achieved. It is important that the windup adjustment not exceed ±30° from the previously set 90° windup position. No further adjustment to the windup spring is permitted after this adjustment is made.
8. Disconnect power from the operating circuit. Remove resistor "A" and replace it with resistor "B." Terminals 5 and 6 should remain shorted together. Set the temperature selection dial to 80°C. Reapply power to the operating circuit.
9. Adjust the slide band on resistor R2 until the IRT left stationary contact (IRT_L) and the moving contacts just make. Tighten the slide band in this position.
10. Disconnect power from the operating circuit. Remove resistor "B" and replace it with resistor "C," or with a resistor having a resistance that corresponds to the resistance of an RTD at some selected temperature. See Selection of Simulated RTD Load for resistor value selection method. Terminals 5 and 6 should remain shorted together. Reapply power to the relay. Set the

temperature selection dial to 120°C if resistor "C" was chosen, or to the temperature that is associated with the resistance value chosen if a value other than resistor "C" is selected. The left IRT contacts (IRTL) should close within $\pm 2^\circ\text{C}$ of the selected temperature dial setting. This completes the overtemperature calibration procedure.

TABLE 9

*

CALIBRATION RESISTOR VALUES

RTD TYPE (Ohms)	RESISTOR "A"	RESISTOR "B"	RESISTOR "C"
10	15.5 ohms	12.4 ohms	14.0 ohms
100	165 "	134 "	149 "
120	265 "	188 "	223 "

11. The IRT51F, IRT51G and IRT51H models are equipped with a reset temperature contact (IRTR). This contact has been set at the factory to close when the sensed temperature falls to 10°C or more below the temperature selected on the temperature selection dial. The reset temperature may be adjusted to any temperature between 5°C and 30°C below the temperature shown on the temperature selection dial. The procedure to do this is as follows:

After completing step 10, which identifies the overtemperature calibration point, mark the location of the temperature selection dial. Do not disturb this dial setting until the reset temperature calibration is complete.

Next, determine the reset temperature with respect to the overtemperature setting. For example, the overtemperature setting that is required for a particular application is 120°C and the desired reset temperature is 110°C. The temperature difference between the two is 10°C. Using the appropriate chart (see Figures 13, 14 or 15) select a resistance value that corresponds to a temperature that is 10°C lower than the overtemperature calibration point that was determined in step 10. Connect this resistance value in the place of resistor "C." To set the reset point, the IRTR contact gap must be adjusted. The wider the gap is made, the lower the reset temperature. To change the IRTR contact gap, loosen the two locking screws of the IRTR contact position dial. Rotate the dial until the right contact and the moving contact just make. Tighten the two locking screws. This sets the reset temperature and completes the reset temperature calibration procedure.

* Revised since last issue

RENEWAL PARTS

Sufficient quantities of renewal parts should be kept in stock for the prompt replacement of any that are worn, broken or damaged.

When ordering renewal parts, address the nearest sales office of the General Electric Company. Specify the name of the part wanted, quantity required, and complete nameplate data of the relay.

www.ElectricalPartManuals.com

LIST OF TABLES

<u>TABLE NO.</u>	<u>TITLE</u>	<u>PAGE</u>
1	Relay Model Description Table	5
2	Target Seal-in Unit Ratings	6
3	Auxiliary Telephone-Type Relay Interrupting Ratings	7
4	Operating Unit Burdens	8
5	Burden for IRT51E - Target Seal-in Unit	9
6	Burden for IRT51F - Auxiliary Circuit	9
7	Burden for IRT51G and IRT51H - Target Seal-in Unit and Auxiliary Circuit	9
8	Lead Wire Resistance	14
9	Calibration Resistor Values	19

LIST OF ILLUSTRATIONS

<u>FIGURE NO.</u>	<u>TITLE</u>	<u>PAGE</u>
1	Type IRT51G and IRT51H Relay, Front View	23
2	Type IRT51G and IRT51H Relay, Right Side View	24
3	Type IRT51G and IRT51H Relay, Left Side and Back View	25
4	Resistance Temperature Detector Assembly	26
5	Telephone Relay	27
6	Drawout Case, Contact Assembly	28
7	Internal Connections Diagram, Type IRT51E Relay	29
8	Internal Connections Diagram, Type IRT51F Relay	30
9	Internal Connections Diagram, Types IRT51G and IRT51H Relays	31
10	External Connections Diagram, Type IRT51E Relay	32
11	External Connections Diagram, Type IRT51F Relay	33
12	External Connections Diagram, Types IRT51G and IRT51H Relays	34
13*	Resistance of 10 ohm Copper RTD versus Temperature When Used With the IRT Relay	35
14*	Resistance of 100 ohm Platinum RTD versus Temperature When Used With the IRT Relay	36
15*	Resistance of 120 ohm Nickel RTD versus Temperature When Used With the IRT Relay	37
16*	Fahrenheit to Centigrade Conversion	38
17*	Outline and Panel Drilling, Type IRT51E and IRT51F Relays	39
18*	Outline and Panel Drilling, Type IRT51G and IRT51H Relays	40

* Revised since last issue

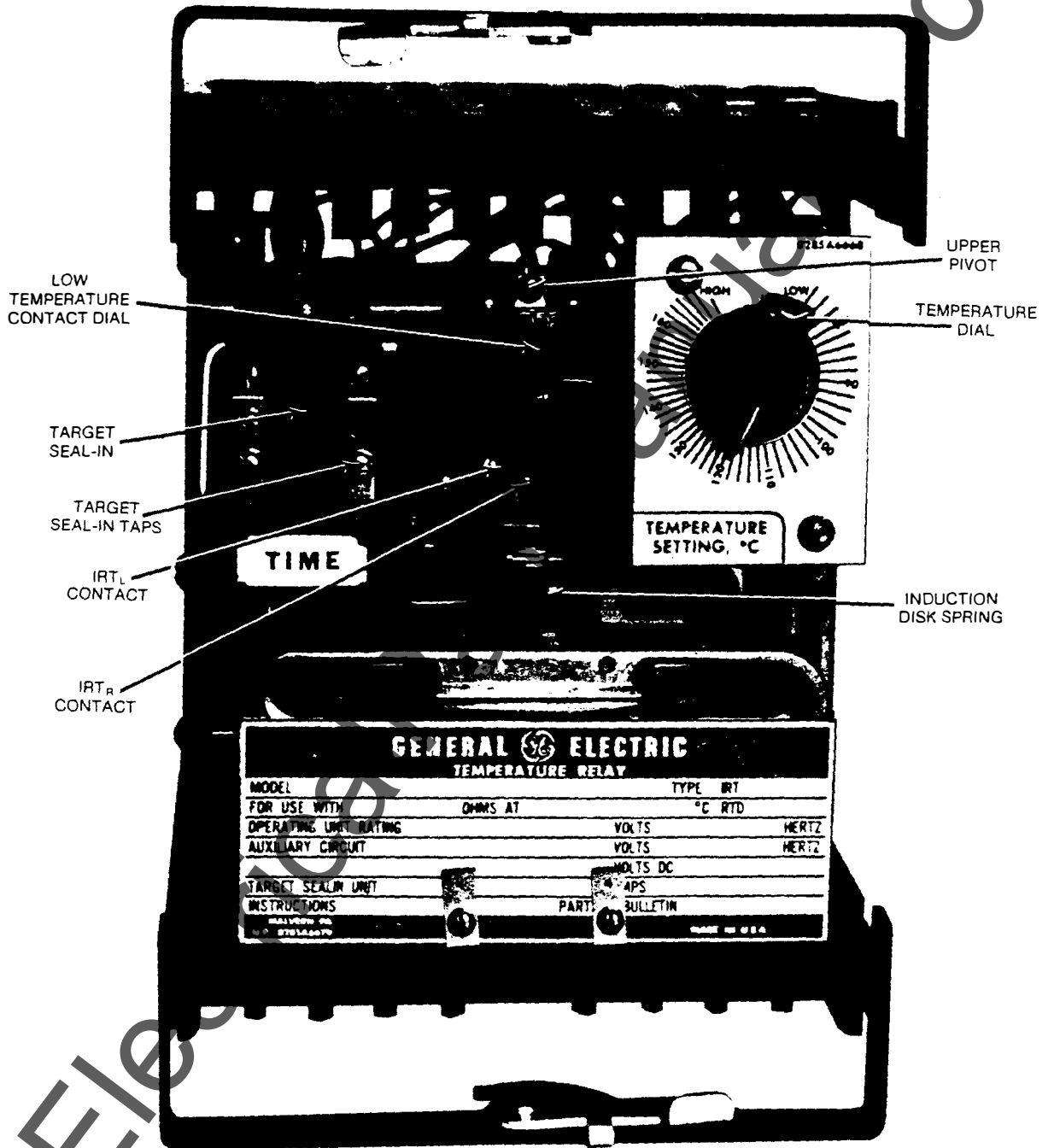

Figure 1 (050283-1) Type IRT51G and IRT51H Relay, Front View

Figure 1 (050283-1) Type IRT51G and IRT51H Relay, Front View

com

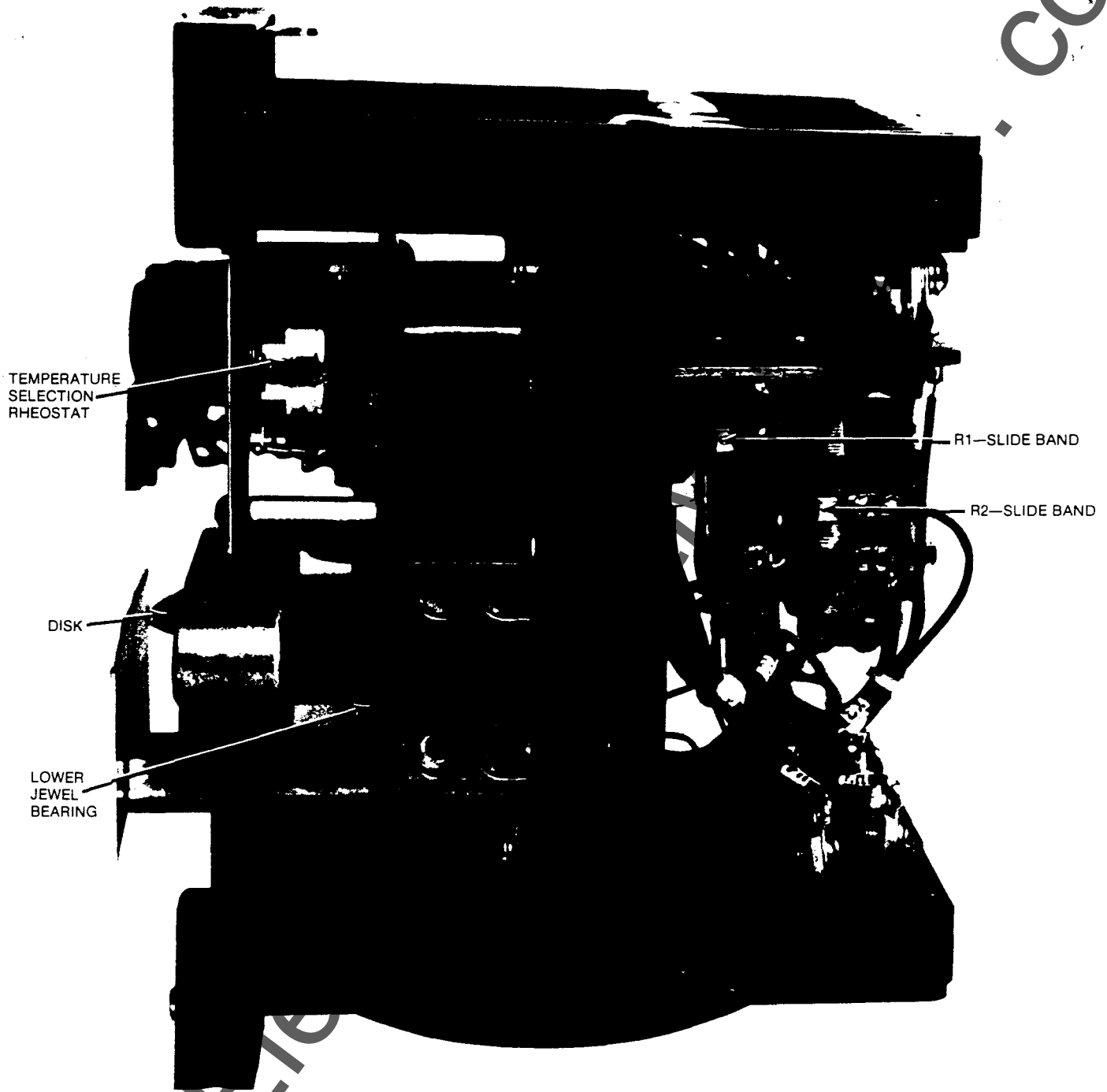

Figure 2 (050283-2) Type IRT51G and IRT51H Relay, Right Side View.

Figure 2 (050283-2) Type IRT51G and IRT51H Relay, Right Side View

WWW

com

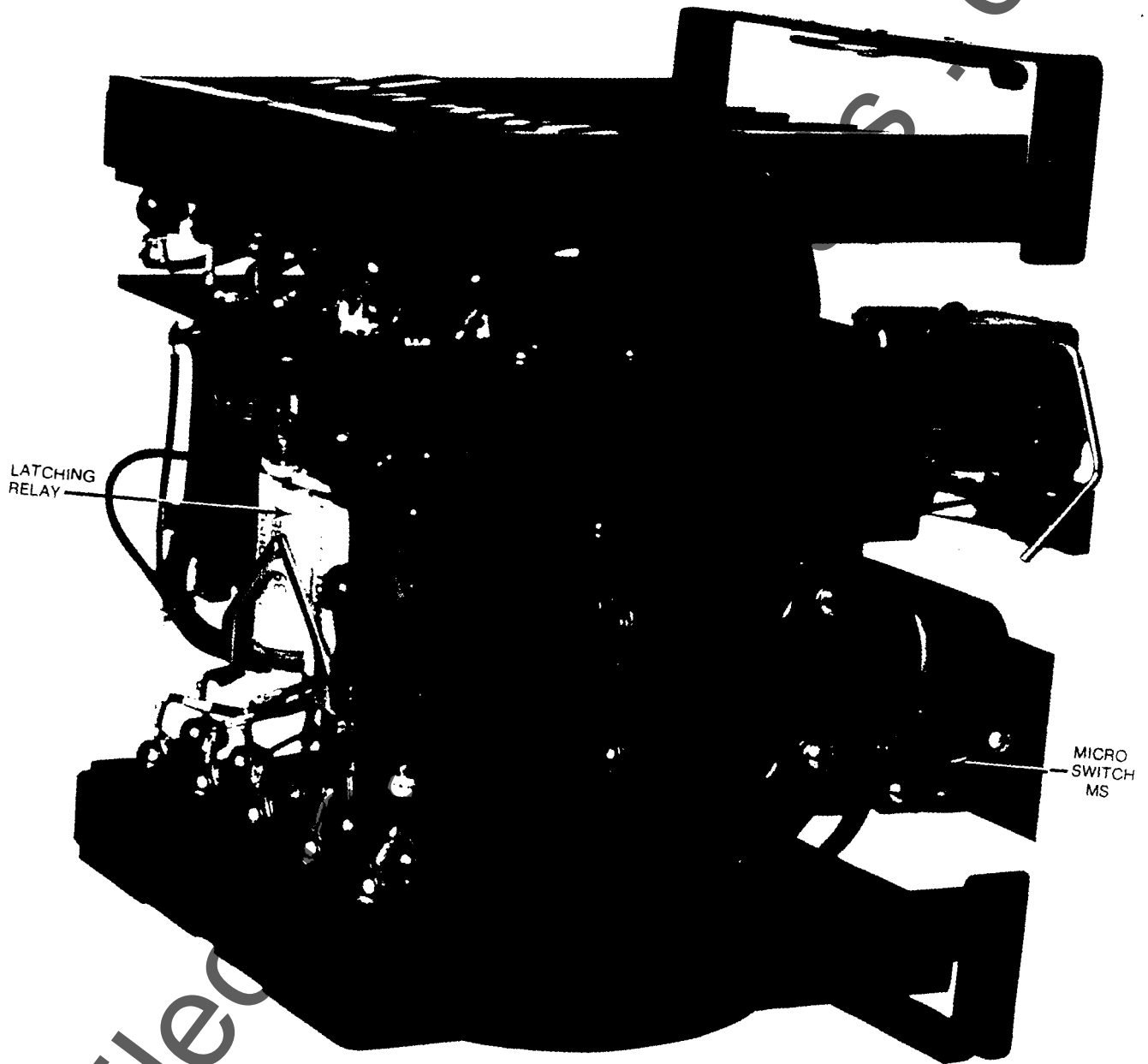

Figure 3 (050283-3) Type IRT51G and IRT51H Relay, Left Side and Back View.

Figure 3 (050283-3) Type IRT51G and IRT51H Relay, Left Side and Back View

WWW.Electronics.com

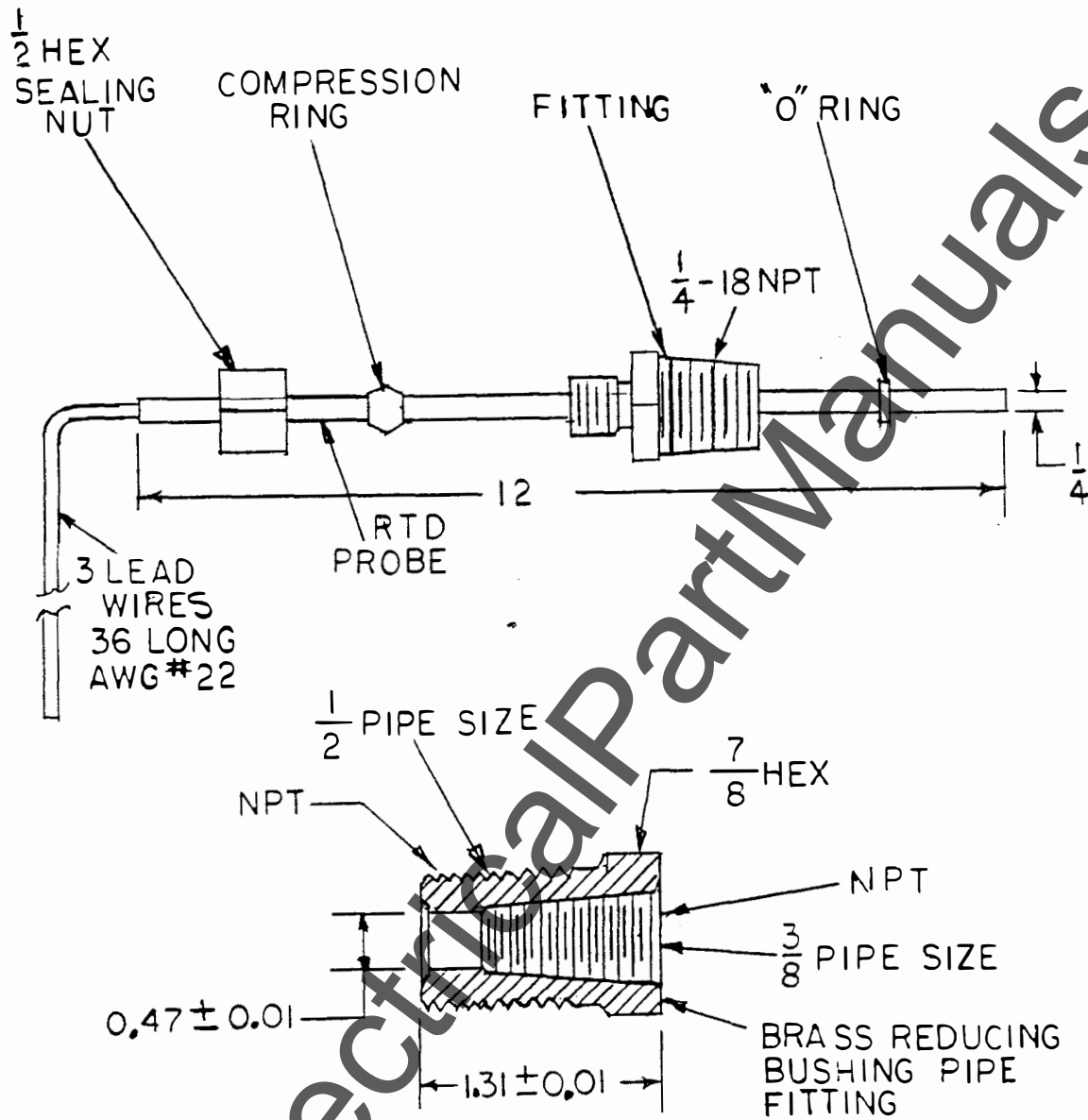

Figure 4 (0285A6731-0) Resistance Temperature Detector Assembly

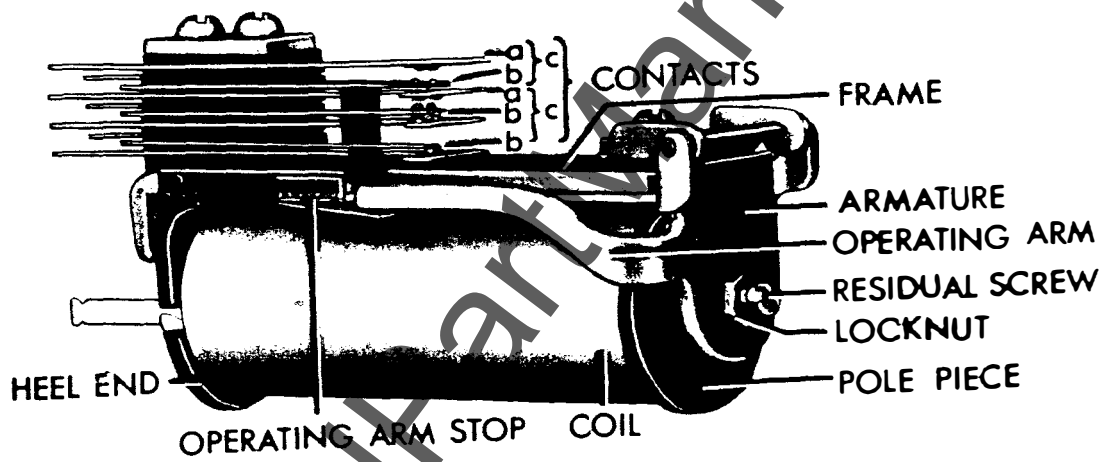
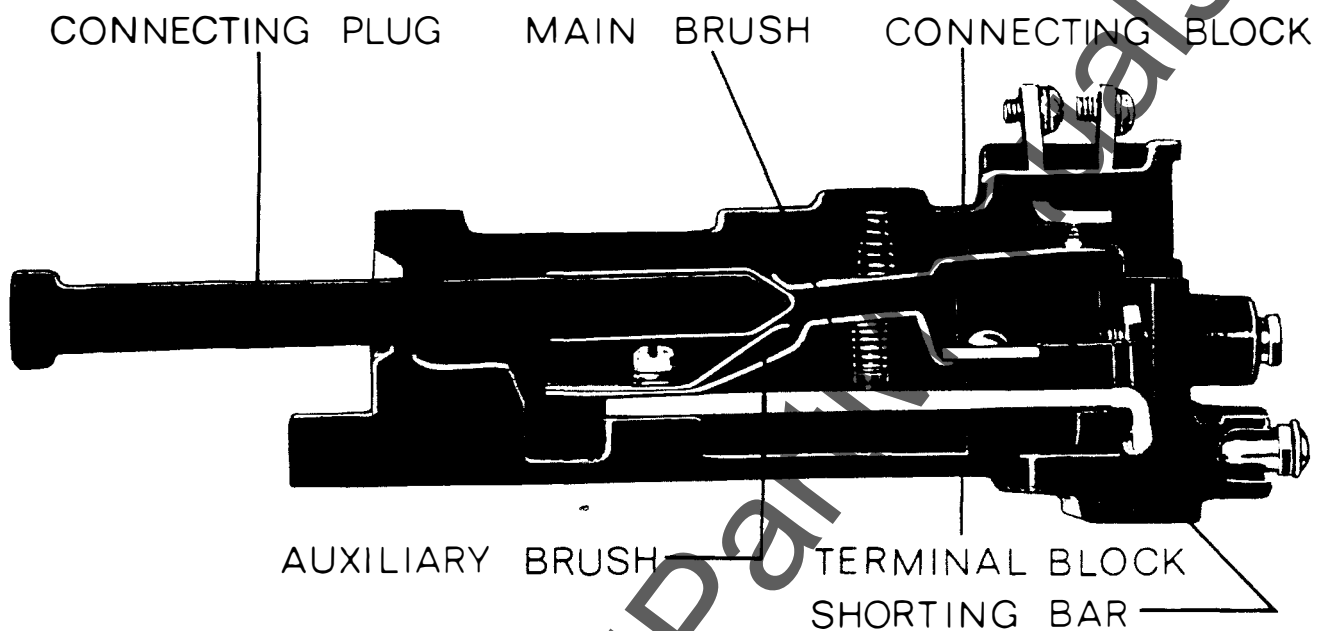

Figure 5 (8012106) Telephone Relay



NOTE: AFTER ENGAGING AUXILIARY BRUSH CONNECTING PLUG TRAVELS $\frac{1}{4}$ INCH BEFORE ENGAGING THE MAIN BRUSH ON THE TERMINAL BLOCK

Figure 6 (8025039) Drawout Case, Contact Assembly

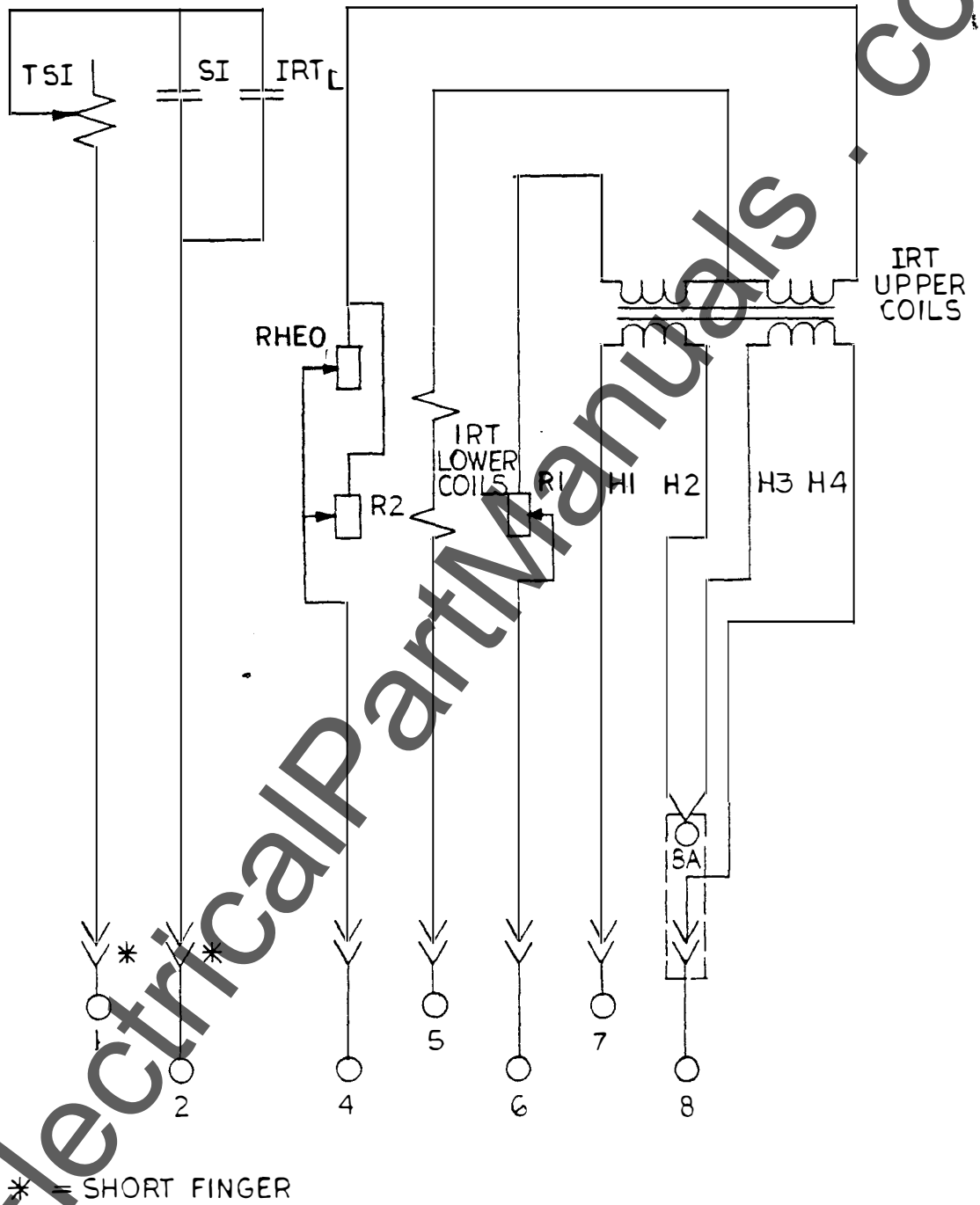

Figure 7 (0285A6213-0) Internal Connections Diagram for the Type IRT51E Relay

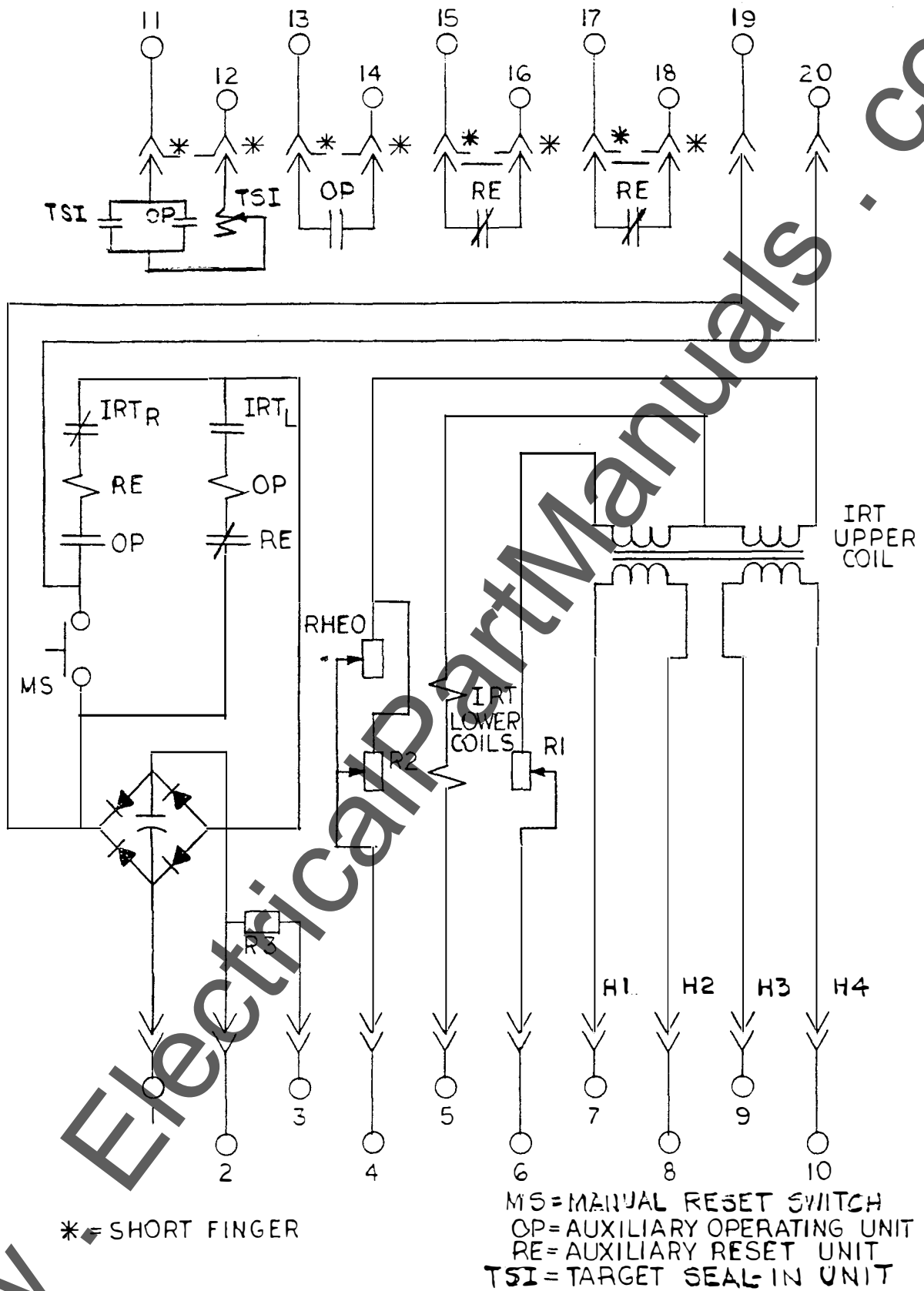
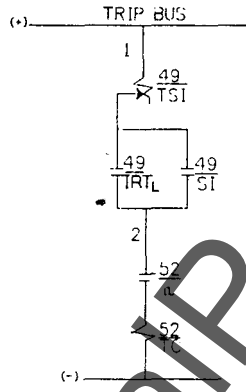
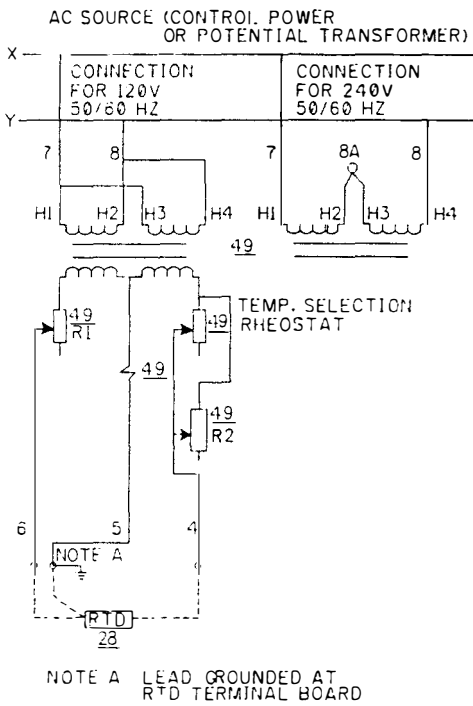

Figure 9 (0285A6215-1) Internal Connections Diagram for the Type IRT51G and IRT51H Relays



DEV. NO.	TYPE	INCLUDED ELEMENT	DESCRIPTION
49	IRT51E	IRT _L	INDUCTION TEMP. RELAY LEFT CONT. (HOT)
		TSI	TARGET SEAL-IN UNIT
52		a	CIRCUIT BREAKER AUX. CONTACT
		TC	TRIP COIL
28			RESIST. TEMP. DETECTOR

Figure 10 (0184B8779-1, Sh. 1) External Connections Diagram for the Type IRT51E Relay

www.ElectricalPartManuals.com

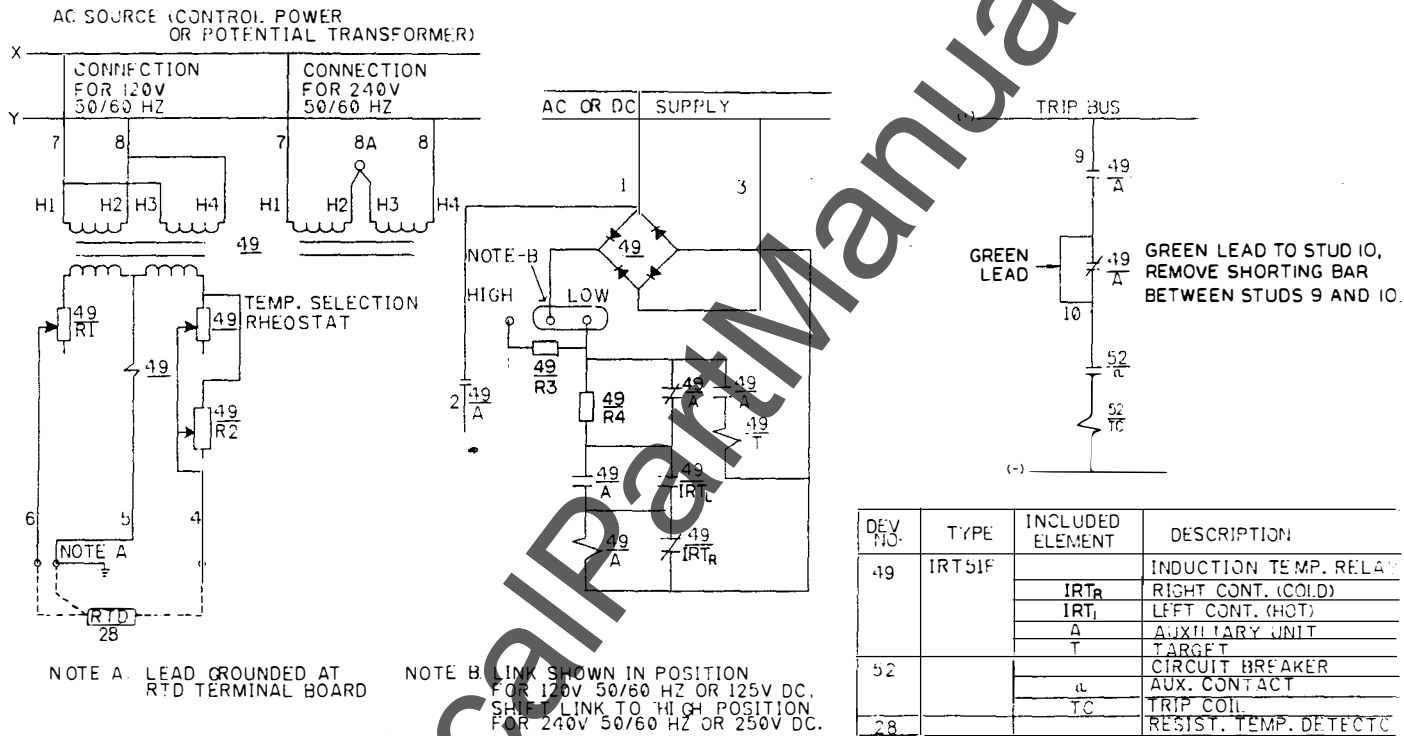
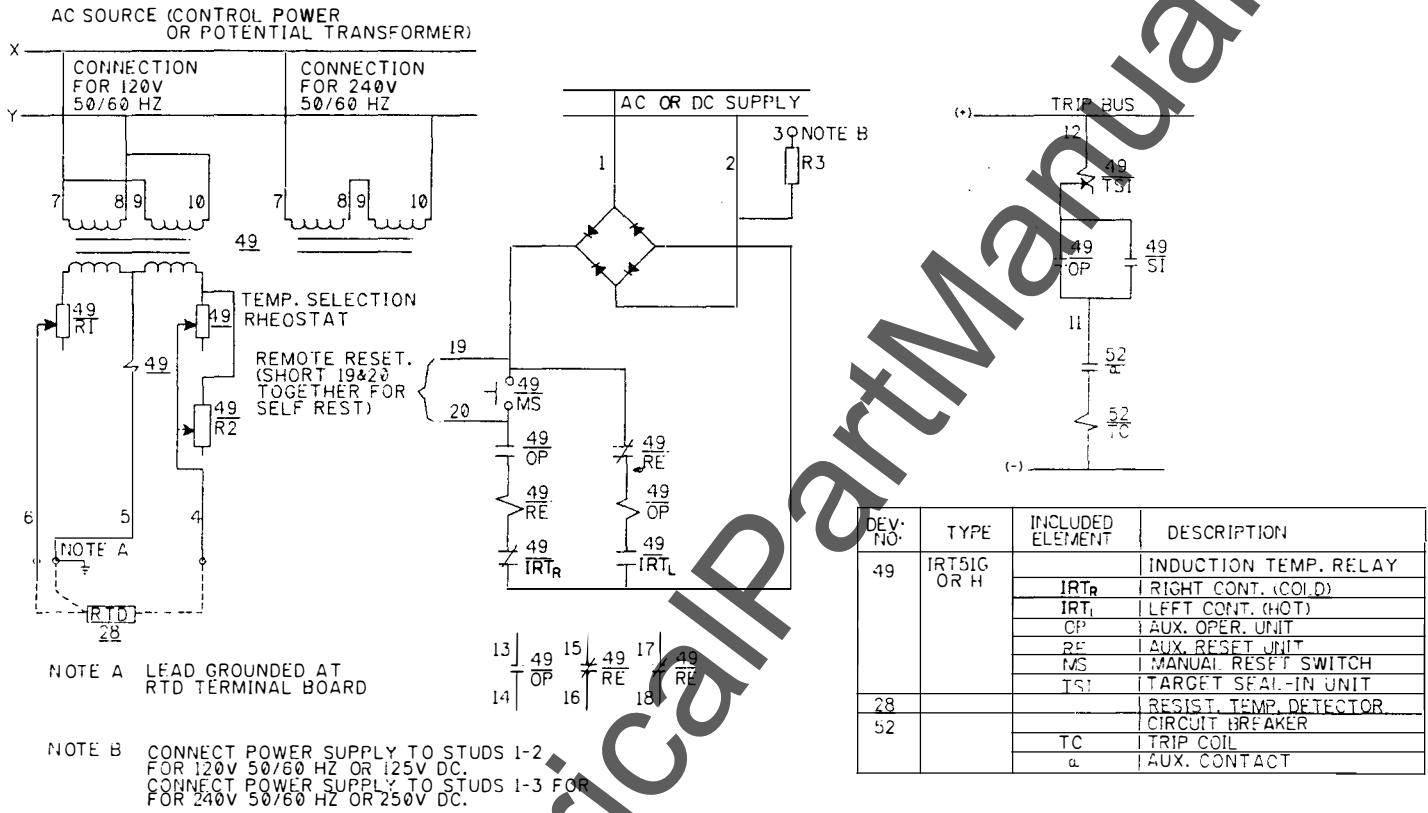

Figure 11 (0184B8779-2, Sh. 2) External Connections Diagram for the Type IRT51F Relay

www.ElectricalPartManuals.com



DEV. NO.	TYPE	INCLUDED ELEMENT	DESCRIPTION
49	IRT51G OR H		INDUCTION TEMP. RELAY
		IRT _R	RIGHT CONT. (COLD)
		IRT _L	LEFT CONT. (HOT)
		OP	AUX. OPER. UNIT
		RE	AUX. RESET UNIT
		MS	MANUAL RESET SWITCH
28			RESIST. TEMP. DETECTOR
52			CIRCUIT BREAKER
		TC	TRIP COIL
		a	AUX. CONTACT

Figure 12 (0184B8779-2, Sh. 3) External Connections Diagram for the Type IRT51G and IRT51H Relays

www.ElectricalPartManuals.com

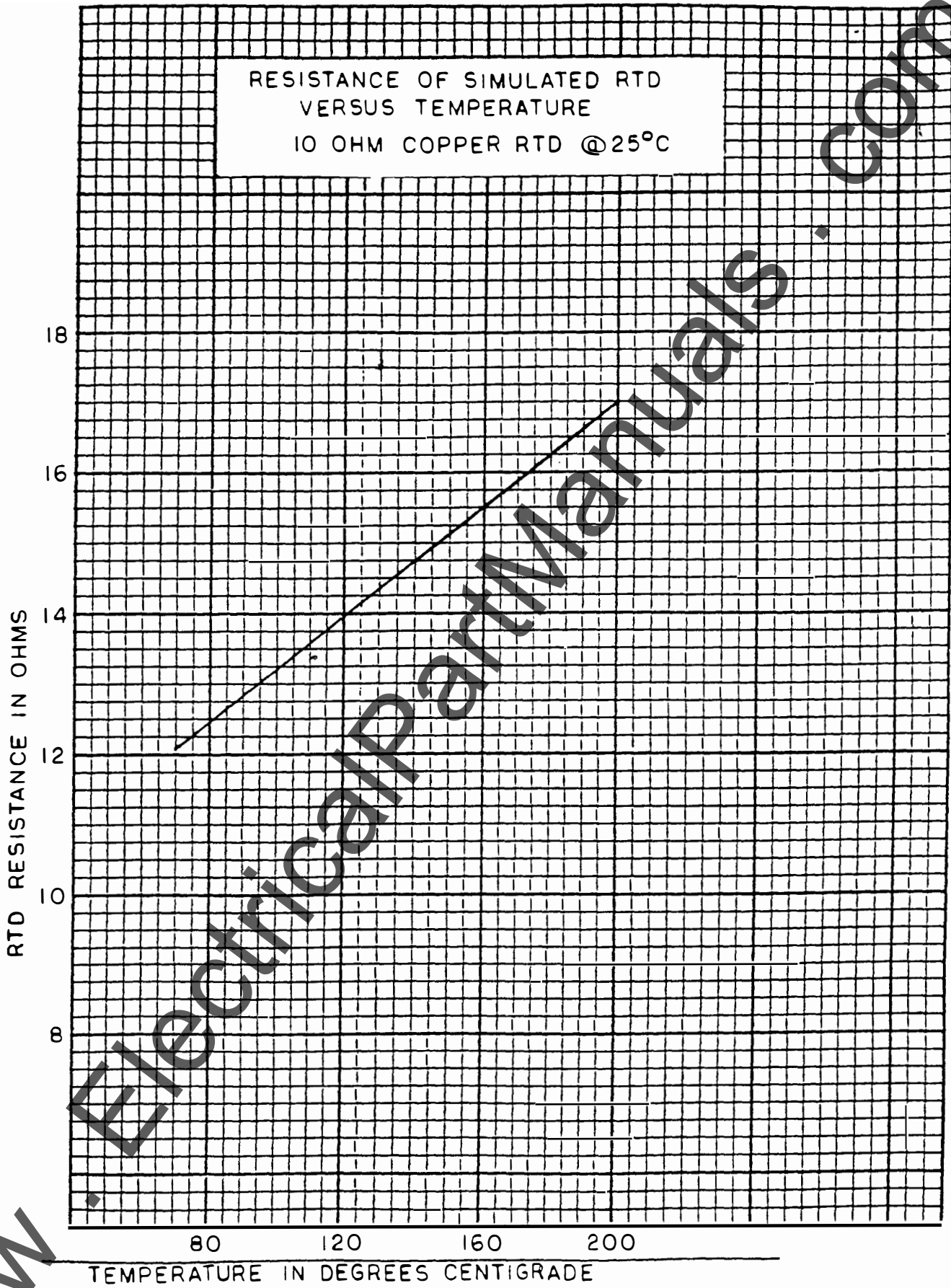

* Figure 13 (0285A6732, Sh. 1 [1]) Resistance of 10 Ohm Copper RTD Versus Temperature When Used With the IRT Relay

* Revised since last issue

www.ElectricalPartManuals.com

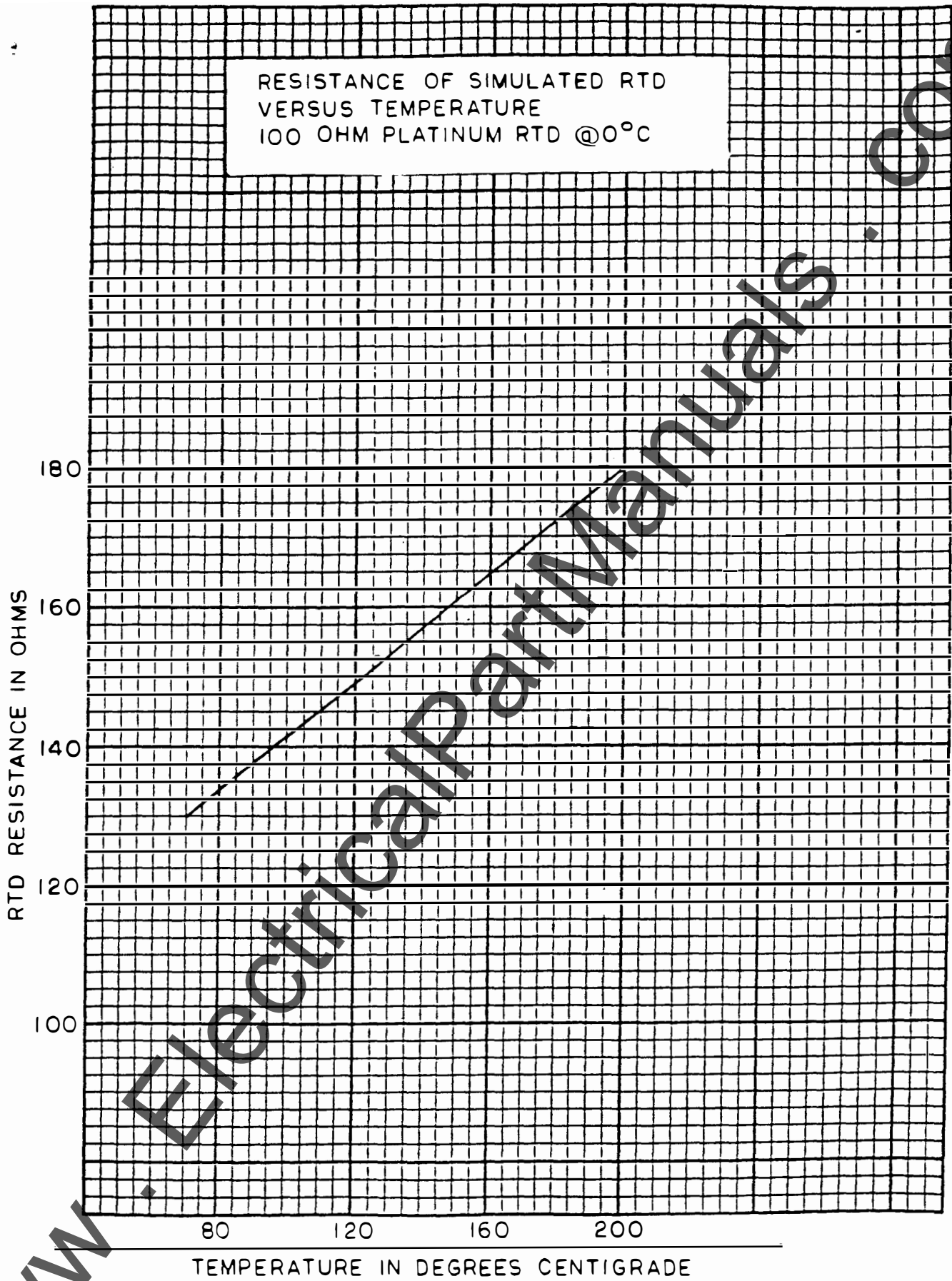
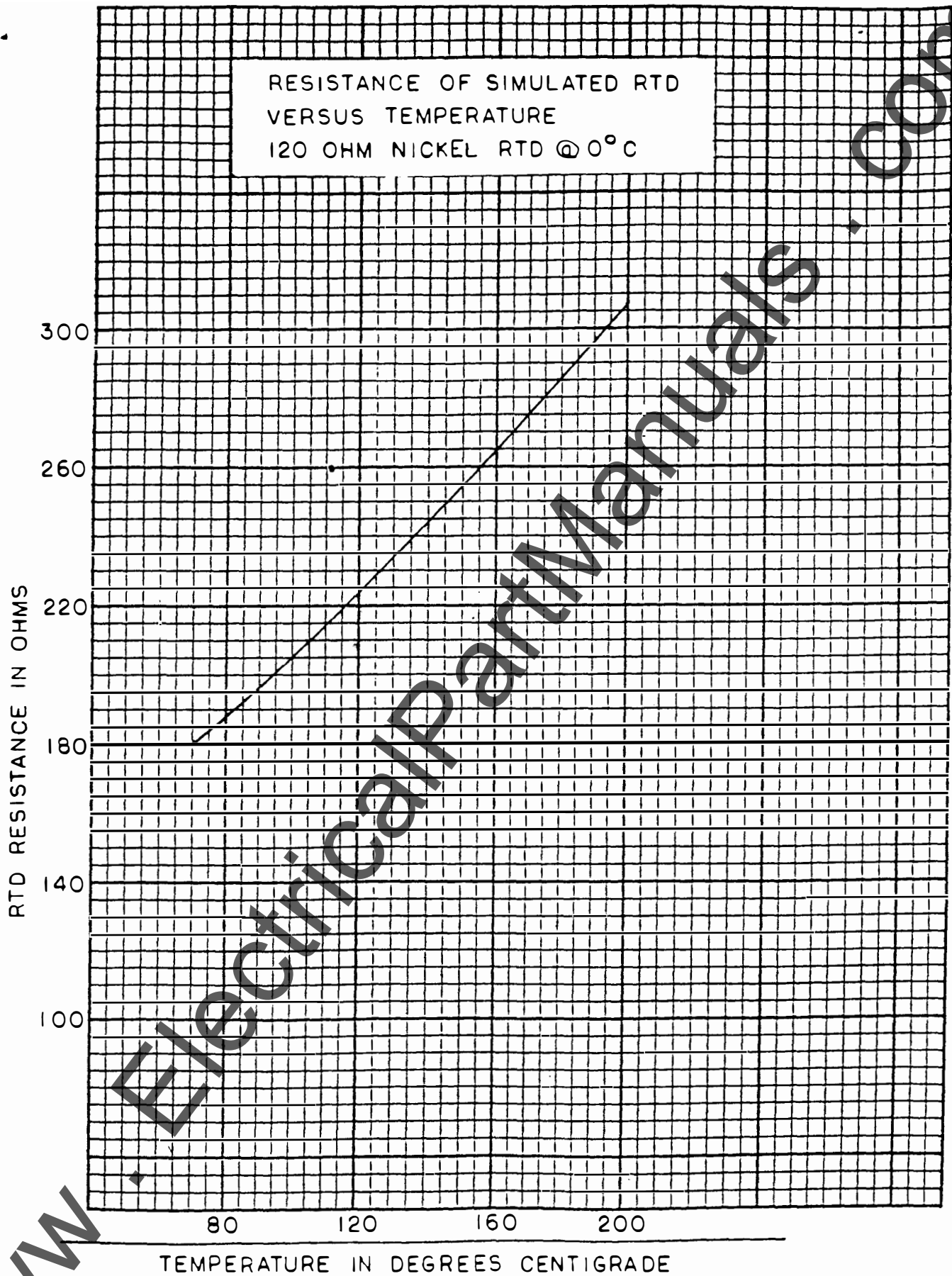

Figure 14 (0285A6732, Sh. 2|1|) Resistance of 100 Ohm Platinum RTD Versus Temperature When Used With the IRT Relay

www.ElectricalPartManuals.com



* Figure 15 (0285A6732, Sh. 3[2]) Resistance of 120 Ohm Nickel RTD Versus Temperature When Used With the IRT Relay

* Revised since last issue

www.ElectricalPartManuals.com

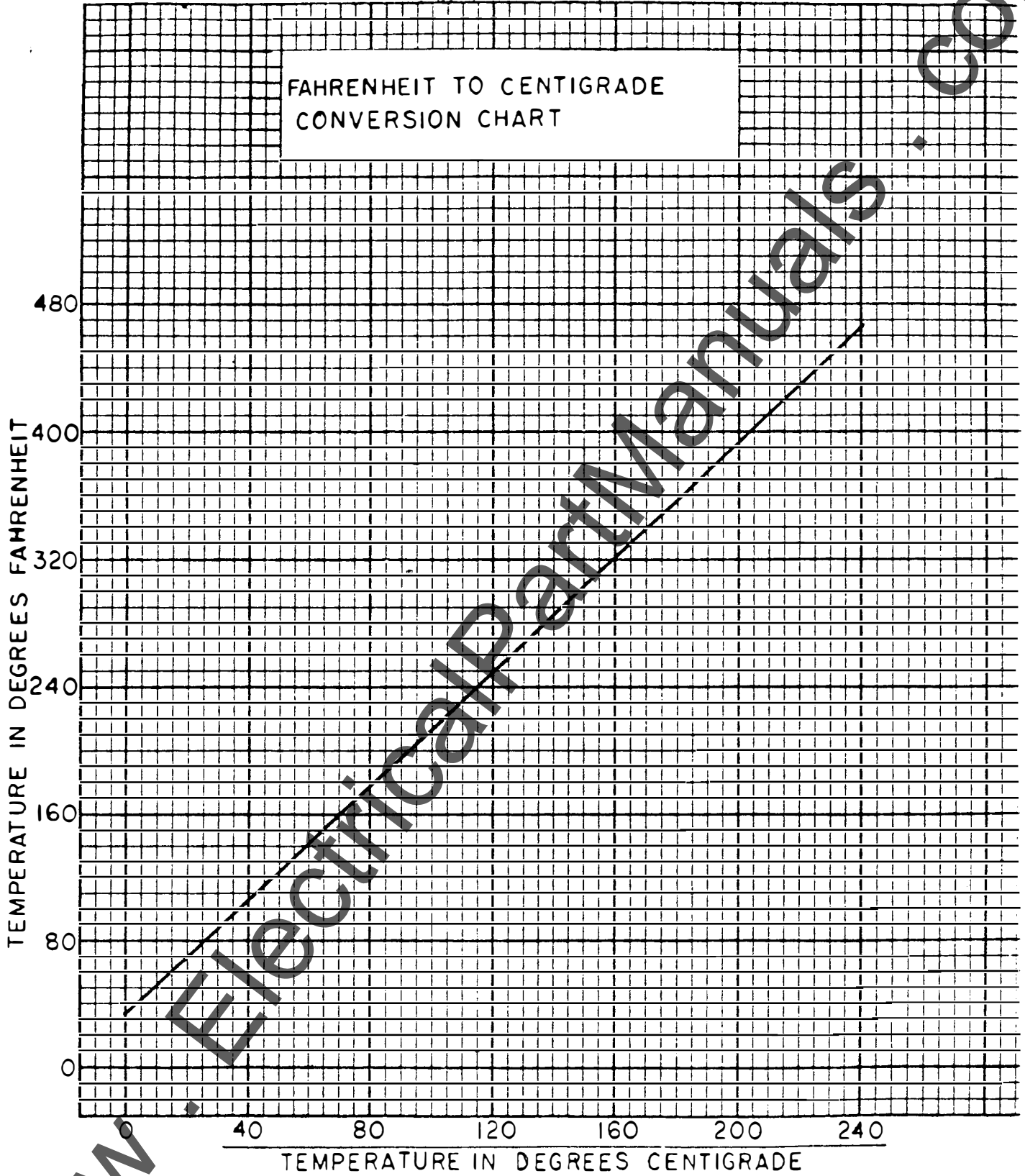

* Figure 16 (0285A6732, Sh. 4 [1]) Fahrenheit to Centigrade Conversion

* Revised since last issue

www.ElectricalPartManuals.com

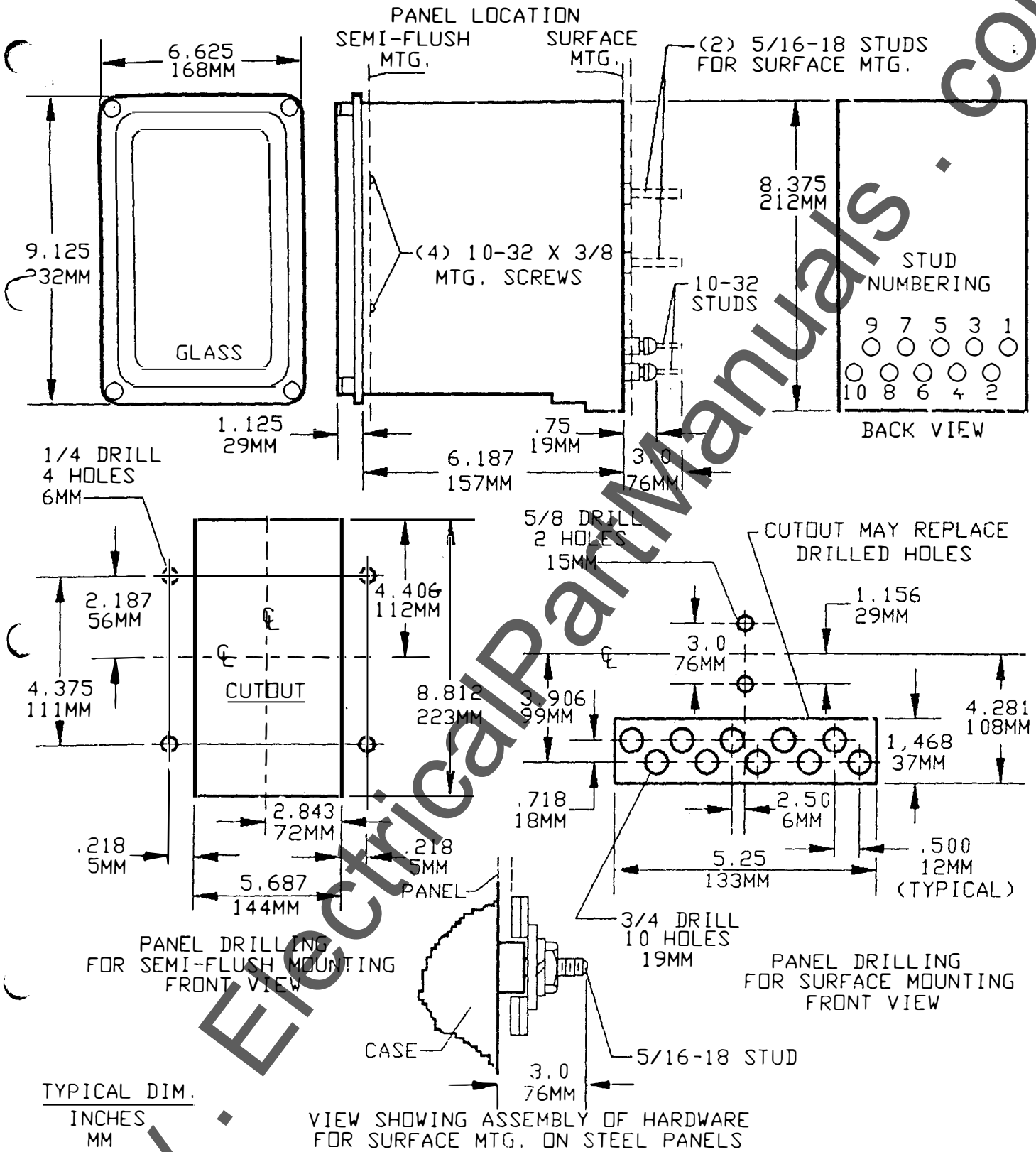

* Figure 17 (006209271 [8]) Outline and Panel Drilling for Type IRT51E and IRT51F Relay

* Revised since last issue

www.ElectricalPartManuals.com

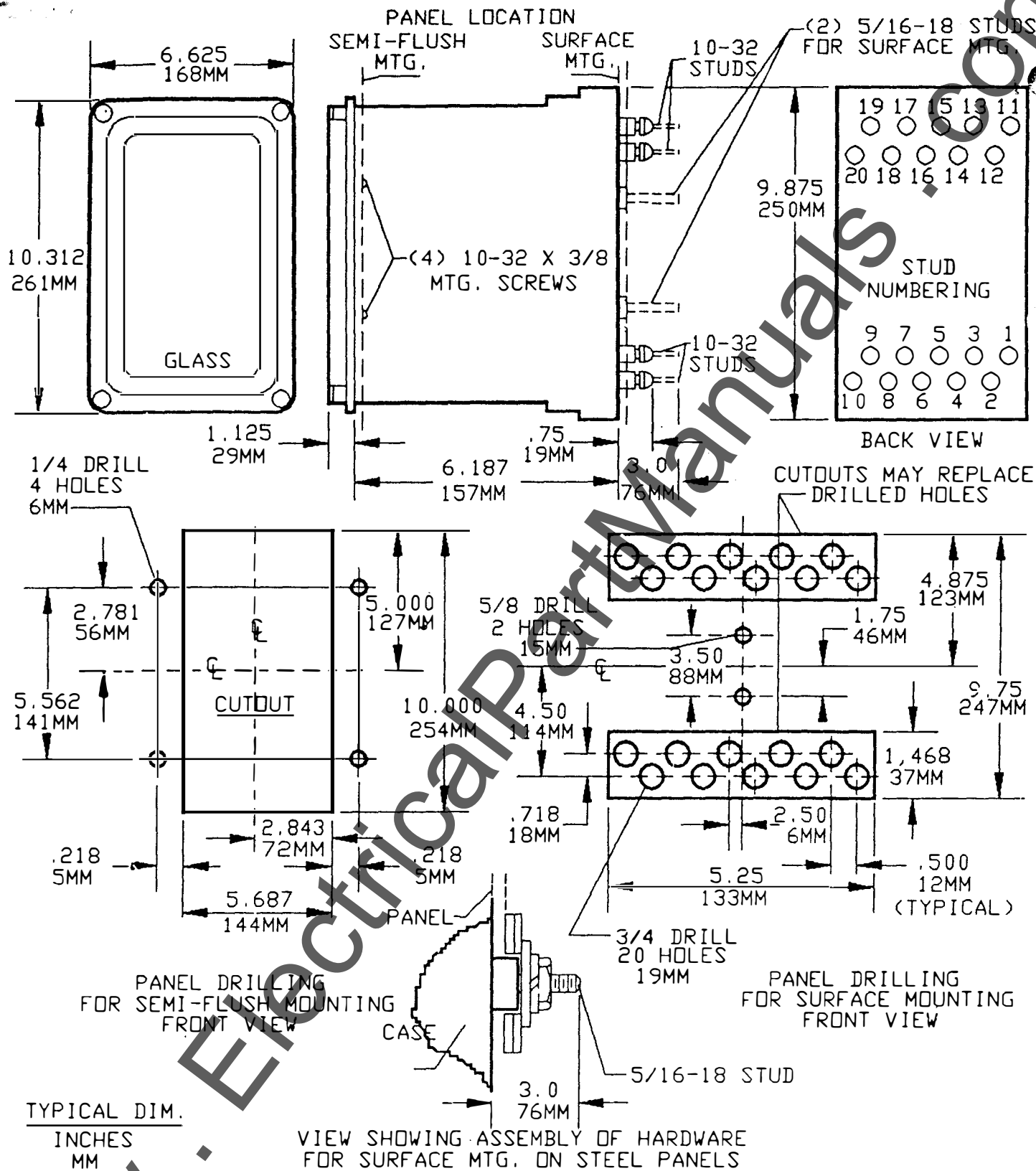

* Figure 18 (006209272 [6]) Outline and Panel Drilling for Type IRT51G and IRT51H Relay

* Revised since last issue

www.ElectricalPartManuals.com