

Applications

CFD22B high-speed, product-restraint relays are designed to provide percentage-differential relaying protection for the larger and more important machines. They are recommended for generators rated 2000 kVA and above and for motors and synchronous condensers rated 3000 hp (or kVA) and above.

Application Factors

Where the total R.M.S. symmetrical current that would flow in a differential relay coil is excessive, high voltage may result with sensitive differential relays, and a Thyrite limiter may be required across each phase of the current transformer secondaries. Where taps on the current transformer secondary windings are unused or do not exist, currents below 84 A are safe without limiters. Where taps are used on the CT secondaries, limiters are not necessary if the current is less than:

$$84 \times \left[\frac{(\text{Active Turns})^2}{(\text{Total Turns})^2} \right]$$

Installations not shown to be safe by the approximate rule given above should be referred to the General Office with data on the fault currents, CT ratios, and CT excitation characteristics, to determine whether limiters are actually needed.

The field switch should be tripped automatically at the same time the machine is disconnected from the system. If the neutral of a machine is grounded directly, or through a low impedance, it is advisable to provide a neutral breaker which can be tripped to open the ground-return circuit of the fault current as quickly as possible.

Current transformers must be accurate within 2 percent to twice

normal current. Above twice normal current accuracy is not so important.

CFD Relays WILL NOT Function for:

1. Turn-to-turn faults in the machine windings.
2. Open circuits in the machine windings.
3. High currents caused by external overloads or short-circuits.
4. Line power surges.
5. Ground between windings and machine frame, if system is ungrounded, unless a second ground occurs in another phase of the system.

CFD Relays WILL Function for:

1. Internal machine faults, except turn-to-turn.
2. Faults in primary cables within the protected differential zone.
3. Ground short-circuits in any part of the machine winding, except a portion very close to the neutral, provided there is no neutral impedance to limit ground current to a value below the relay pickup calibration.

Product-restraint Principle

The CFD relays function on the product-restraint principle, which gives very little, or zero, restraining torque on single-end-feed internal faults, and an operating torque from the restraint coils on internal faults, with an external source of power.

If a current flows from the neutral side into the generator and another current flows from the generator to the bus, then the restraining coils produce a restraining torque that is proportional to the product of these two currents and the cosine of the angle between them. These are the conditions that will exist during normal operation, during external faults, and during internal faults when the generator continues to supply some current to the bus.

Conversely, if a current flows from the neutral side into the generator and another current flows from the bus into the generator, then the restraining

Connection Diagram

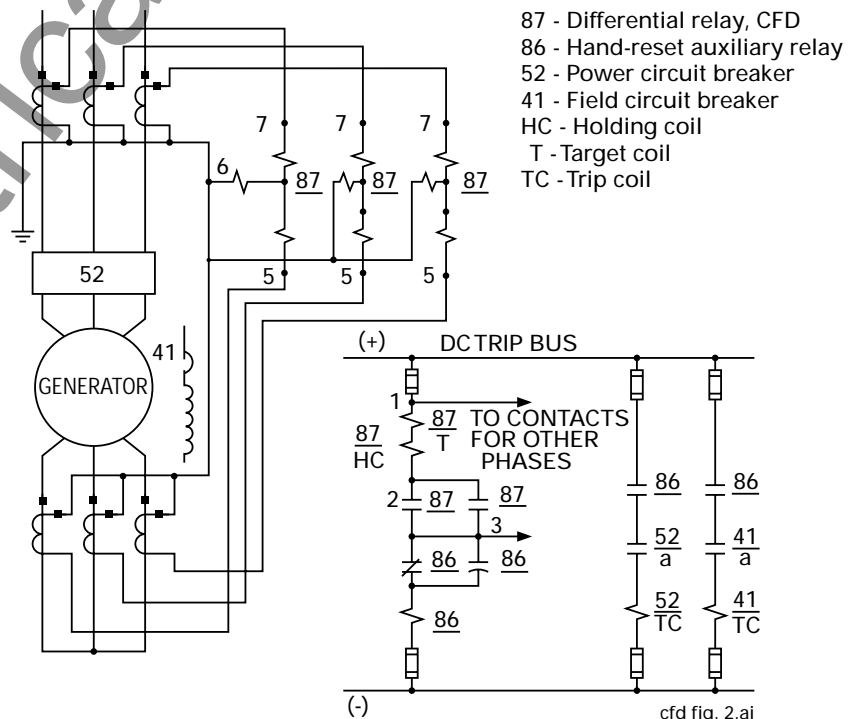

coils produce an operating torque that is proportional to the product of these two currents and the cosine of the angle between them. These are the conditions that will exist during an internal fault when part of the fault current comes from the bus.

Percentage Slope: The relay has a slope which increases very rapidly above approximately twice normal current. This feature eliminates the necessity for close "matching" of the current transformers.

Under normal conditions the two secondary currents should be equal but they may differ due to current transformer errors. The "difference" or "error" current will flow in the operating coil. For currents up to full load of the machine the error current will be less than the 10 percent "difference" current required to operate the relay. With an external fault the current in the current transformers can be high and the "error" current may be well over 10 percent. For this reason, the

slope of the relay characteristic is made to increase as the current increases.

Selection Guide

Ratings			Contacts Normally Open Per Unit	Target and Holding Coil (A)	Model No.	Case Size	Approx. Wt. in lbs (kg)					
Cont Rating in Amps	Frequency in Hz	Min. P.U. Amp					Net	Ship				
SINGLE-PHASE (3 REQUIRED)												
5	60	0.2	2	1	CFD22B1A B2A B3A B4A	S1	12 (5.5)	18 (8.1)				
	50			0.2								
THREE-PHASE												
5	60	0.2	2	1					CFD22A1A CFD22A2A CFD22A3A CFD22A4A	L2	35 (15.9)	45 (20.4)
	50			0.2								
VOLTAGE LIMITER FOR LINE CURRENT TRANSFORMER SECONDARY – SINGLE PHASE												
----	----	-----	----	----	6118766G3	—	1 (0.45)	2 (0.91)				

Burdens

The burdens of the coils in one phase (one induction unit) at 60 Hertz are given below:

Circuit	Continuous Rating (A)	Burden on one CT	
		PF	VA
Restraining	5	0.57	0.9
Operating ^①	0.5	0.81	14.4

① Calculated unsaturated values (VA at 0.5 A)

The operating circuit burden as a function of differential current is given in the table below. The burden is imposed on one current transformer.

Current (A)	Multiple of Min. Pickup Current	Burden on One CT Impedance (Ω)
0.2	1	58
0.6	3	29
2.0	10	11
4.0	20	6.3
5.0	25	5.4

Simplify the order process – visit our on-line store

www.GEindustrial.com/pm