



FREQUENCY RELAYS

TYPES

IJF51A, IJF51B,
and IJF52A



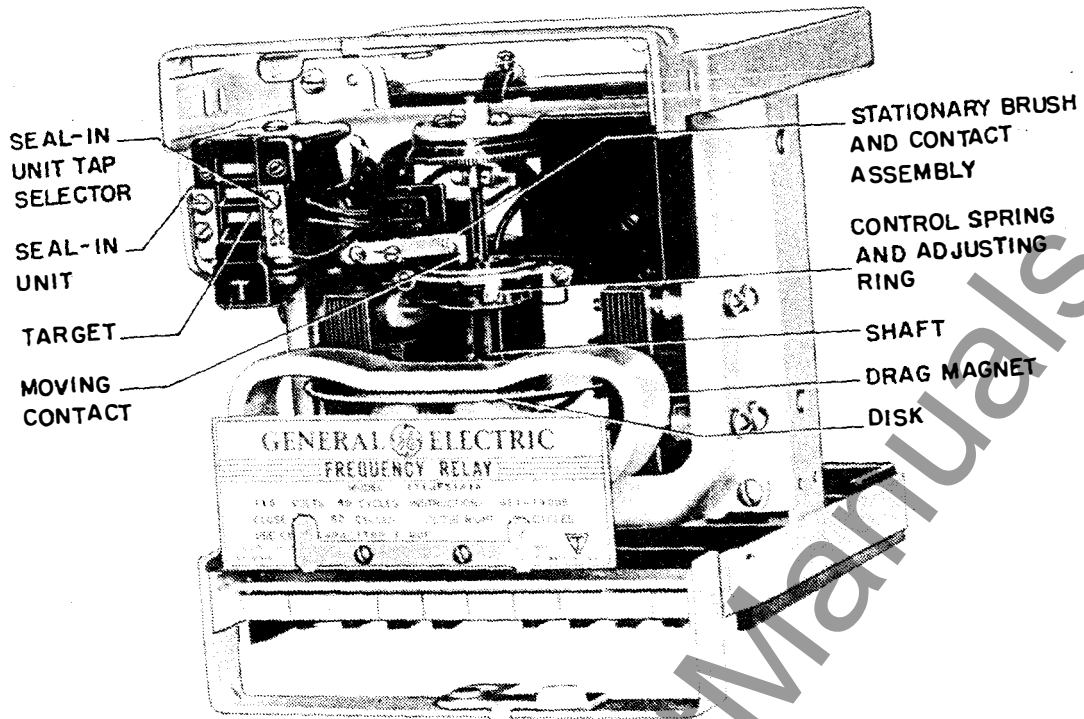

Fig. 1 Type IJF Relay Removed From Case (Front View)

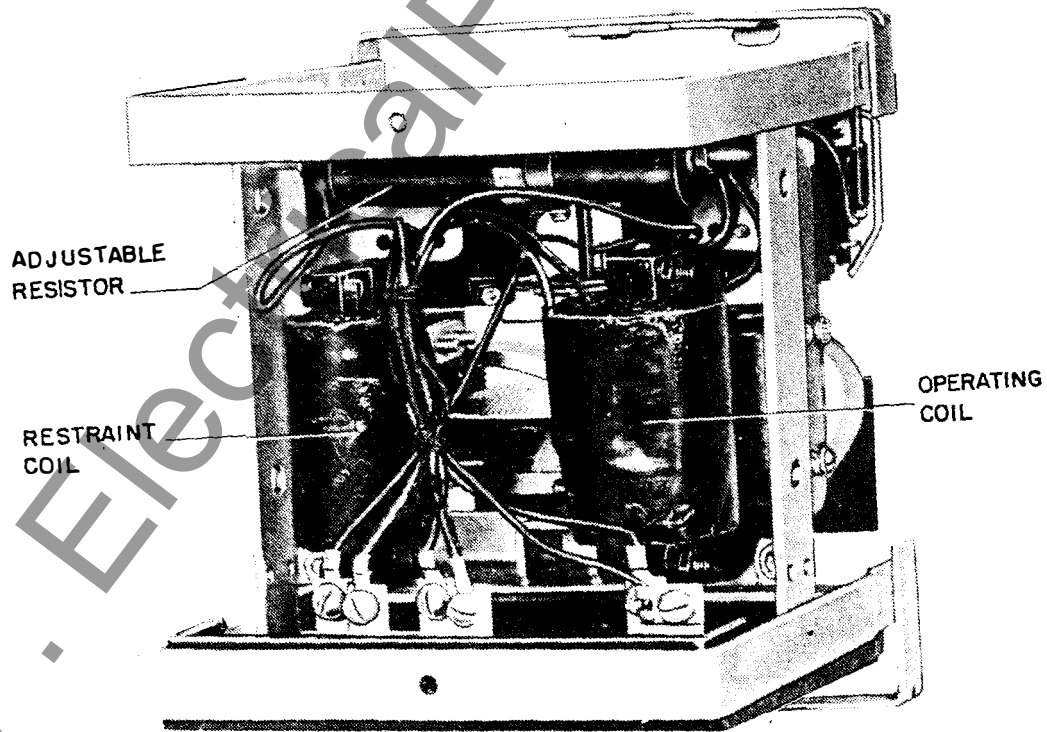

Fig. 2 Type IJF Relay Removed From Case (Rear View)

Fig. 1 (8009059)

Fig. 2 (8009060)

FREQUENCY RELAYS

TYPE IJF

INTRODUCTION

These are relays of the induction disk type intended for the protection of apparatus against the effects of overfrequency or underfrequency.

The Type IJF is an induction disk type relay mounted in a single unit drawout case. It has two shaded-pole U-magnet type driving elements acting on opposite sides of the disk. One of these, the operating element, is designed to drive the disk in the direction to close the left contacts, and the other, the restraining element to drive the disk in the contact-opening direction on relays having single-throw contacts and to close the right contacts on relays having double-throw contacts. The disk shaft is restrained by a spiral spring, the principal purpose of which is to hold the contacts open when the relay is de-energized. The motion of the disk is retarded by permanent magnets to give the correct time delay for closing the contacts.

There is a seal-in unit mounted to the left of the shaft on the Type IJF51A and IJF51B relays. The Type IJF52A relay has a seal-in unit mounted on both sides of the shaft. This element has its coil in series and its contacts in parallel with the main contacts such that when the main contacts close, the seal-in element picks up and seals in. When the seal-in element picks up it raises a target into view which latches up and remains exposed until released by pressing a button beneath the lower left corner of the cover.

The case is suitable for either surface or semiflush panel mounting and an assortment of hardware is provided for either mounting. The cover attaches to the case and also carries the reset mechanism when one is required. Each cover screw has provision for a sealing wire.

The case has studs or screw connections at both ends or at the bottom only for the external connections. The electrical connections between the relay units and the case studs are made through spring backed contact fingers mounted in stationary molded inner and outer blocks between which nests a removable connecting plug which completes the circuits. The outer blocks, attached to the case, have the studs for the external connections, and the inner blocks have the terminals for the internal connections.

The relay mechanism is mounted in a steel framework called the cradle and is a complete unit with all leads being terminated at the inner block. This cradle is held firmly in the case with a latch at the top and the bottom and by a guide pin at the

back of the case. The cases and cradles are so constructed that the relay cannot be inserted in the case upside down. The connecting plug, besides making the electrical connections between the respective blocks of the cradle and case, also lock the latch in place. The cover, which is fastened to the case by thumbscrews, holds the connecting plug in place.

To draw out the relay unit the cover is first removed, and the plug drawn out. Shorting bars are provided in the case to short the current transformer circuits. The latches are then released, and the relay unit can be easily drawn out. To replace the relay unit, the reverse order is followed.

A separate testing plug can be inserted in place of the connecting plug to test the relay in place on the panel either from its own source of current and voltage, or from other sources. Or, the relay unit can be drawn out and replaced by another which has been tested in the laboratory.

APPLICATION

The Type IJF frequency relays are recommended for protection of synchronous apparatus against overspeed or underspeed conditions caused by loss of load in the case of generators, or loss of supply power in the case of motor and condensers. The relays can be used to operate protective devices, or to sound an alarm whenever the frequency of the circuit varies by a predetermined amount above or below normal.

RATINGS

These relays are available in frequency ratings from 25 to 60 cycles and voltage ratings of 115 and 230 volts.

The current closing rating of the contacts is 30 amperes for voltages not exceeding 250 volts. The current-carrying ratings are affected by the selection of the tap on the seal-in coil as indicated in Table I.

TABLE I

Function	Amperes, AC or DC	
	2-Amp Tap	0.2 Amp Tap
Tripping Duty	30	5
Carry Continuously	3	0.3

These instructions do not purport to cover all details or variations in equipment nor to provide for every possible contingency to be met in connection with installation, operation or maintenance. Should further information be desired or should particular problems arise which are not covered sufficiently for the purchaser's purposes, the matter should be referred to the General Electric Company.

To the extent required the products described herein meet applicable ANSI, IEEE and NEMA standards; but no such assurance is given with respect to local codes and ordinances because they vary greatly.

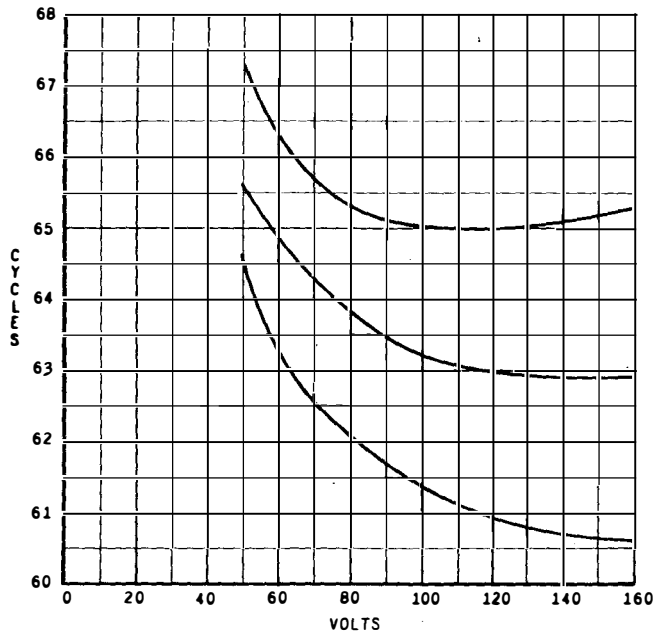

Fig. 3 Type IJF51A Relay, Voltage-Frequency Characteristics

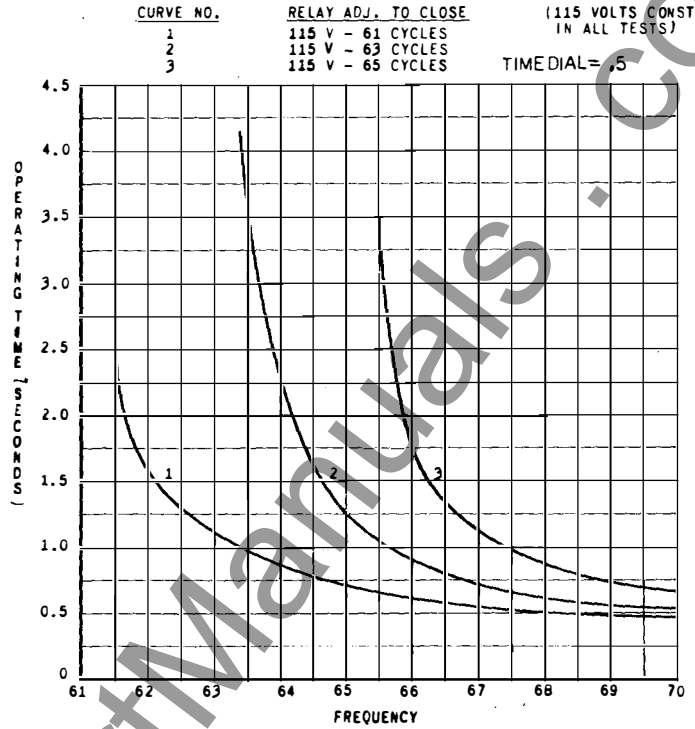

Fig. 4 Type IJF51A Relay, Time-Frequency Characteristics

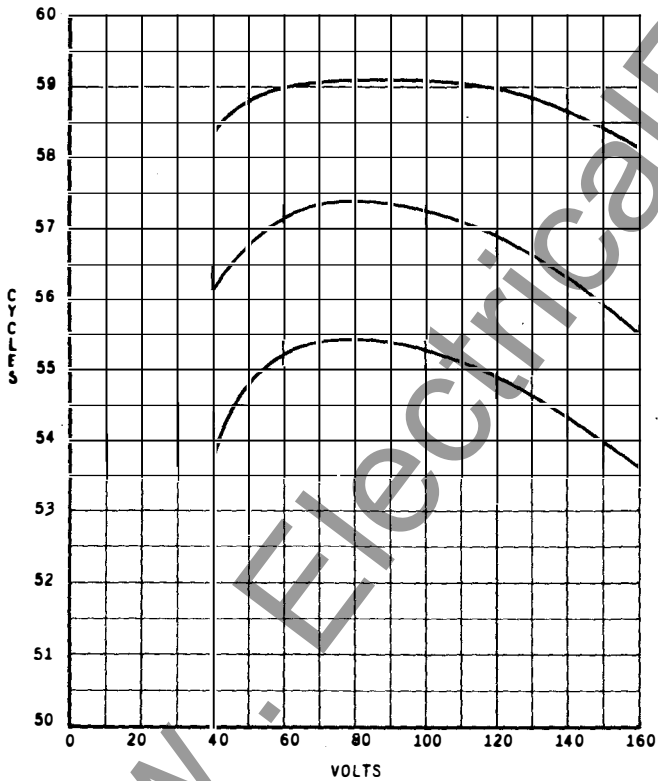

Fig. 5 Type IJF51B Relay, Voltage-Frequency Characteristics

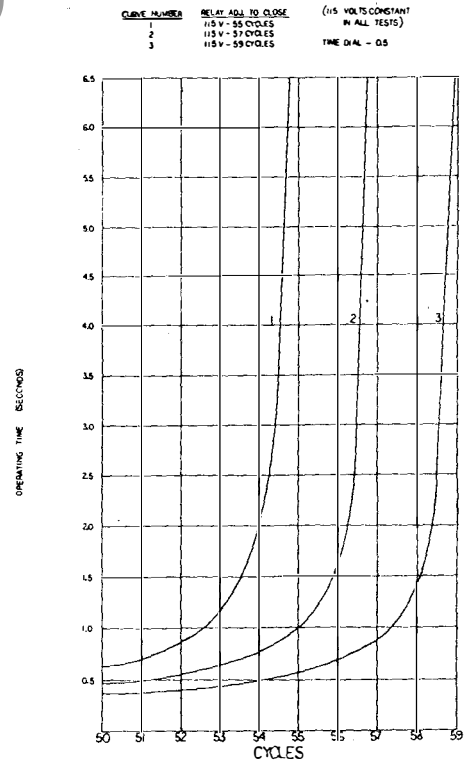

Fig. 6 Type IJF51B Relay, Time-Frequency Characteristics

* Indicates Revision

*Fig. 3 (K-400147 [1])

*Fig. 4 (K-400148 [2])

*Fig. 5 (K-400146 [1])

*Fig. 6 (K-400149 [2])

The 2-ampere tap has a d-c resistance of 0.13 ohms and a 60 cycle impedance of 0.53 ohms while the 0.2-ampere tap has a 7 ohm d-c resistance and a 52 ohm 60 cycle impedance. The tap setting used on the seal-in element is determined by the current drawn by the trip coil.

The 0.2-ampere tap is for use with trip coils that operate on currents ranging from 0.2 up to 2.0 amperes at the minimum control voltage. If this tap is used with trip coils requiring more than 2 amperes, there is a possibility that the 7-ohm resistance will reduce the current to so low a value that the breaker will not be tripped.

The 2-ampere tap should be used with trip coils that take 2 amperes or more at minimum control voltage, provided the tripping current does not exceed 30 amperes at the maximum control voltage. If the tripping current exceeds 30 amperes an auxiliary relay should be used, the connections being such that the tripping current does not pass through the contacts or the target and seal-in coils of the protective relay.

BURDENS

Burden data for the 55-60 cycle under frequency relay and 60-65 cycles overfrequency relays are given in Table I at 115 volts 60 cycles.

Burdens listed are total burden of relay.

TABLE II

Relay	Volt Amps	Power Factor	Watts
LJF51A	8.7	.99	8.6
LJF51B	5.8	.98	5.7

Total burdens for the Type LJF52A relay at 115 volts are as follows:

TABLE III

Freq.	Volt Amps	Power Factor	Watts
25	6.3	.95	6
60	10.7	.89	9.5

RECEIVING, HANDLING AND STORAGE

These relays, when not included as a part of a control panel, will be shipped in cartons designed to protect them against damage. Immediately upon receipt of the relay, an examination should be made for any damage sustained during shipment. If injury or damage resulting from rough handling is evident, a claim should be filed at once with the transportation company and the nearest Sales Office of the General Electric Company notified promptly.

Reasonable care should be exercised in un-

packing the relay in order that none of the parts are injured or the adjustments disturbed.

If the relays are not to be installed immediately, they should be stored in their original cartons in a place that is free from moisture, dust, and metallic chips. Foreign matter collected on the outside of the case may find its way inside when the cover is removed and cause trouble in the operation of the relay.

INSTALLATION

LOCATION

The location should be clean and dry, free from dust and excessive vibration, and well lighted to facilitate inspection and testing.

MOUNTING

The relay should be mounted on a vertical surface. The outline and panel diagram is shown in Fig. 12.

CONNECTIONS

Internal connection diagrams for the various relay types are shown in Fig. 7 to 9 inclusive. Typical wiring diagrams are given in Fig. 10 and 11.

One of the mounting studs or screws should be permanently grounded by a conductor not less than No. 12 B&S gage copper wire or its equivalent.

AUXILIARIES

When external capacitors, and in some cases resistors, are furnished with relays they are identified by means of serial numbers. These numbers are of the form KX-1023 or OA-2155. The purpose of these numbers is to insure that each relay, when installed, will be provided with the same auxiliaries with which it was calibrated at the factory.

The reason for this precaution is to eliminate the variation in calibrations of the relays which would otherwise result from the variation in electrical properties of the auxiliaries.

ADJUSTMENTS

TARGET AND SEAL-IN ELEMENT

For trip coils operating on currents ranging from 0.2 up to 2.0 amperes at the minimum control voltage, set the target and seal-in tap plug in the 0.2-ampere tap.

GEI-19008 Frequency Relays Type IJF

For trip coils operating on currents ranging from 2 to 30 amperes at the minimum control voltage, place the tap plug in the 2-ampere tap.

The tap screw is the screw holding the right-hand stationary contact of the seal-in unit. To change the tap setting, first remove the connecting plug. Then take a screw from the left-hand stationary contact and place it in the desired tap. Next, remove the screw from the other tap, and place it in the left-hand contact. This procedure is necessary to prevent the right-hand stationary contact from getting out of adjustment. Screws should not be in both taps at the same time as pickup for d-c will be the higher tap value.

PICKUP

Pickup of the relays can be set for any frequency from minimum to maximum values inclusive as shown in Tables IV, V and VI.

To make the setting, apply the desired frequency at rated volts to the relay and adjust the resistor until the relay just picks up. The relay must be in the case for an accurate check of the operating point.

The relay is adjusted at the factory to have the pickup called for on the requisition or, if pickup is not specified, at the applicable nominal value shown in Tables IV, V and VI.

TABLE IV PICKUP CALIBRATION - IJF51A RELAY

RELAY MODEL	RATED		CALIBRATION-CYCLES TO CLOSE LEFT CONTACT		
	VOLTS	FREQUENCY	MINIMUM	MAXIMUM	NOMINAL
IJF51A1A	115	60HZ	61	65	63
IJF51A2A	115	60HZ	57	60	58
IJF51A3A	115	60HZ	51	55	53
IJF51A4A	115	60HZ	65	75	70
IJF51A5A	115	60HZ	45	49	47
IJF51A6A	115	60HZ	38	46	44
IJF51A7A	115	60HZ	58	62	60
IJF51A9A	115	150HZ	153	165	159
IJF51A10A	115	60HZ	60	70	65
IJF51A11A	115	60HZ	55	65	61
IJF51A12A	115	140HZ	143	155	148
IJF51A13A	115	160HZ	162	172	167

TABLE V PICKUP CALIBRATION - IJF51B RELAY

RELAY MODEL	RATED		CALIBRATION-CYCLES TO CLOSE LEFT CONTACT		
	VOLTS	FREQUENCY	MINIMUM	MAXIMUM	NOMINAL
IJF51B1A	115	60HZ	-	-	45
IJF51B2A	115	60HZ	55	59	57
IJF51B3A	115	50HZ	45	49	47
IJF51B4A	115	25HZ	22.5	24.5	23.5
IJF51B5A	115	60HZ	48	55	52
IJF51B7A	220	50HZ	45	49	47
IJF51B8A	115	60HZ	50	60	55

TABLE VI PICKUP CALIBRATION - IJF52A RELAY

RELAY MODEL	RATED		CYCLES TO CLOSE LEFT CONTACT			RIGHT CONTACT CLOSSES (CYCLES ABOVE LEFT)	
	VOLTS	FREQUENCY	MINIMUM	MAXIMUM	NOMINAL	MINIMUM	MAXIMUM
IJF52A1A	115	25HZ	23	27	25	0.4	1.0
IJF52A2A	230	25HZ	23	27	25	0.4	1.0
IJF52A3A	115	50HZ	49	51	50	0.8	2.0
IJF52A4A	115	60HZ	55	65	59	0.75	2.0

TIME

Operating time of the relay for a given condition is determined by the position of the drag magnet on its shelf. Moving the drag magnet toward the disk shaft decrease pick-up time while moving it away from the disk shaft increases pick-up time.

Normally the time dial at the top of the disk shaft is readily adjustable with the fingers to give any time delay desired, within certain limits. It is

usually difficult, in the field, to obtain odd frequencies for checking the pick-up time. As a precaution then against having the time dial accidentally disturbed with no means available for resetting it, the time dial is locked in position at the factory to give the desired time. If it is desired to change the position of the time dial, this may be done by loosening the 2 screws through the frame just above the dial. Turning the dial counter-clockwise (top view) increases the contact travel and hence the time. Tighten the screws when the setting has been completed.

PRINCIPLES OF OPERATION

The Type LJF51A relay is an overfrequency relay having a single-circuit normally open contact which closes on overfrequency.

The Type LJF51B relay is an underfrequency relay having a single-circuit normally open contact which closes on underfrequency.

The Type LJF52A relay is an overfrequency and underfrequency relay having double throw contacts. The left contacts close on underfrequency and the right contacts close on overfrequency.

Discrimination between normal frequency and abnormal frequency is accomplished by the opposite variation in impedance with frequency of two circuits, one circuit containing the coil of one U-magnet connected directly to the voltage supply and designated as the inductive circuit, the other circuit containing the coil of the remaining U-magnet in series with an external capacitor connected to the same supply voltage and designated as the capacitive circuit, because the capacitive reactance predominates at normal frequency.

In the underfrequency relay, the coil of the operating U-magnet composes the inductive circuit, and the coil of the restraining U-magnet in series with the capacitor composes the capacitive circuit.

At normal frequency the torque produced by the current through the capacitive circuit (restraining U-magnet) is greater than the torque produced by the current (operating U-magnet). A decrease in the frequency of the supply voltage is accompanied by a decrease in the impedance of the inductive circuit permitting an increase of the operating current, while the impedance of the capacitive circuit increases, thereby reducing the restraining current. Thus as the supply frequency is decreased the operating U-magnet overcomes the restraining U-magnet and the relay operates.

The overfrequency relay differs from the underfrequency relay in that the operating U-magnet coil is in the capacitive circuit and the restraining U-magnet coil forms the inductive circuit. Consequently, the torque of the inductive element is adjusted to preponderate at normal frequency.

Voltage-frequency characteristics are shown in Fig. 3 for the 60 cycle LJF overfrequency relays. Fig. 5 shows the voltage-frequency characteristics of the 60 cycle LJF undervoltage relay.

Time-frequency characteristics for the 60 cycle LJF overfrequency relays are shown in Fig. 4. Time frequency curves for the 60 cycle LJF underfrequency relays are shown in Fig. 6.

MAINTENANCE

The relays are adjusted at the factory and it is advisable not to disturb the adjustments. If for any reason, they have been disturbed, the following points should be observed in restoring them:

DISK AND BEARINGS

The lower jewel may be tested for cracks by exploring its surface with the point of a fine needle. If it is necessary to replace the jewel a new pivot should be screwed into the bottom of the shaft at the same time. The jewel should be turned up until the disk is centered in the air gaps, after which it should be locked in this position by the set screw provided for this purpose. The upper bearing pin should next be adjusted until very little end play can be felt between the pin and the steel ball in the recess at the top of the shaft; about 0.015 inch is correct.

CONTACT CLEANING

For cleaning fine silver contacts, a flexible burnishing tool should be used. This consists of a flexible strip of metal with an etched roughened surface, resembling in effect a superfine file. The polishing action is so delicate that no scratches are left, yet corroded material will be removed rapidly and thoroughly. The flexibility of the tool insures the cleaning of the actual points of contact.

Fine silver contacts should not be cleaned with knives, files, or abrasive paper or cloth. Knives or files may leave scratches which increase arcing and deterioration of the contacts. Abrasive paper or cloth may leave minute particles of insulating abrasive material in the contacts and thus prevent closing.

The burnishing tool described is included in the standard relay tool kit obtainable from the factory.

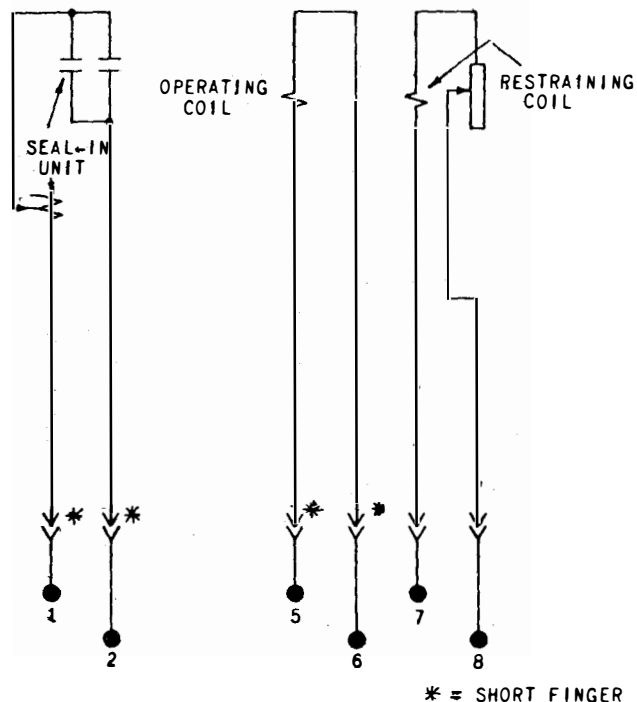

*Fig. 7 (K-6306813 [2]) Type IJF51A Relay, Internal Connections (Front View)

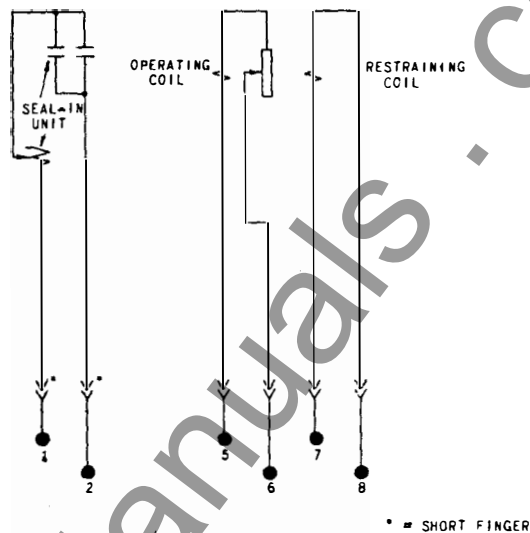
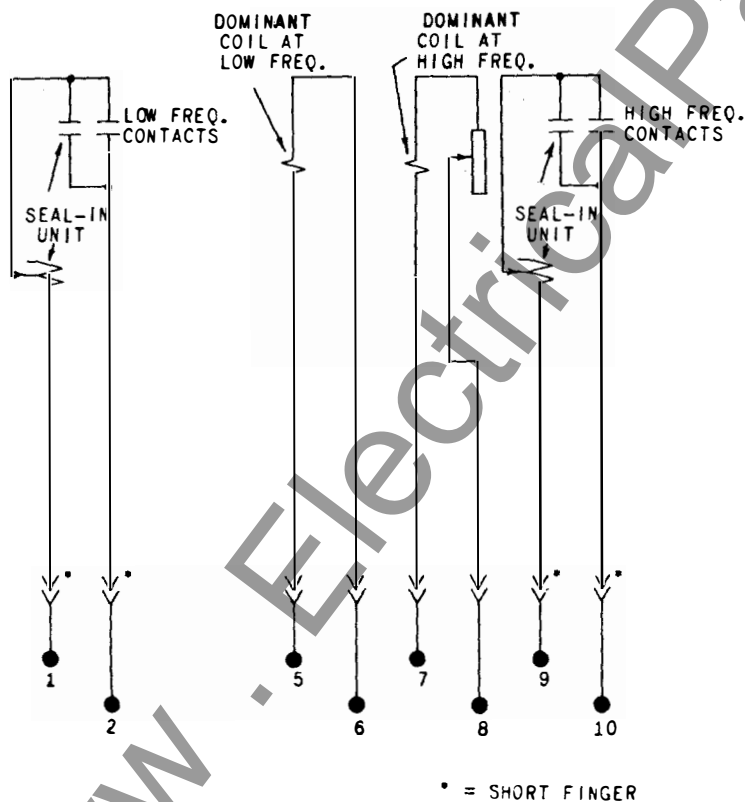

Fig. 8 (K-6306616) Type IJF51B Relay, Internal Connections (Front View)



*Fig. 9 (K-6400202 [2]) Type IJF52A Relay, Internal Connections, (Front View)

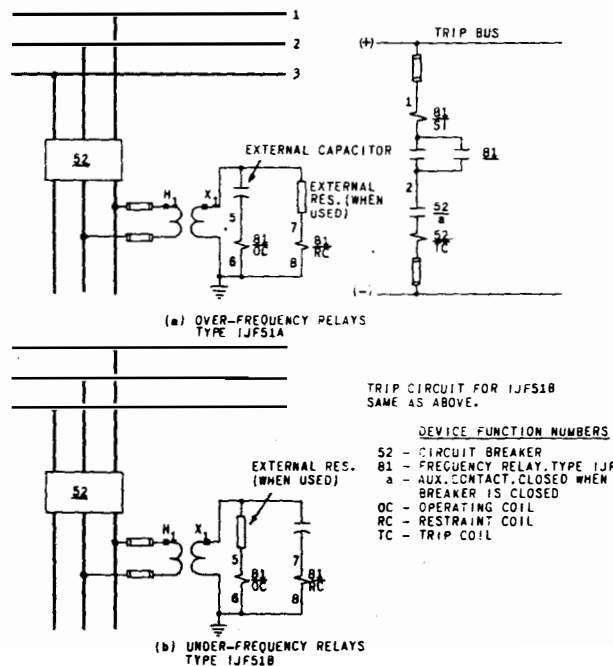

Fig. 10 (K-6154254-3) Typical External Connections For The Type IJF51A and IJF51B Relays

RENEWAL PARTS

It is recommended that sufficient quantities of renewal parts be carried in stock to enable the prompt replacement of any that are worn, broken, or damaged.

When ordering renewal parts, address the

nearest Sales Office of the General Electric Company, specify quantity required, name of part wanted, and give complete nameplate data, including serial number. If possible, give the General Electric Company requisition number on which the relay was furnished.

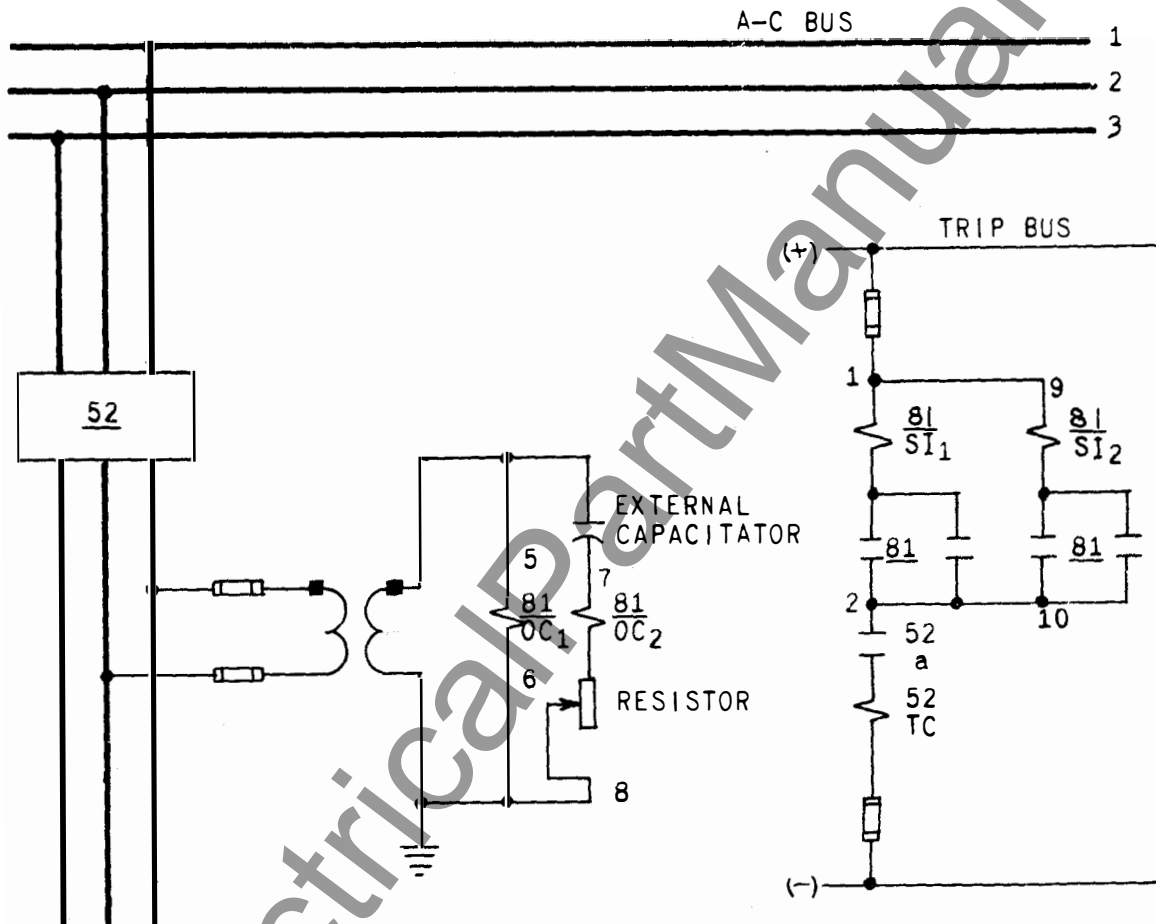

DEVICE FUNCTION NUMBERS

- 52 - CIRCUIT BREAKER
- 81 - FREQUENCY RELAY TYPE IJF
- a - AUXILIARY CONTACT CLOSED WHEN BREAKER IS CLOSED
- OC1 - OPERATING COIL FOR UNDER-FREQUENCY
- OC2 - OPERATING COIL FOR OVER-FREQUENCY
- SI² - SEAL-IN UNITS - UNDER AND OVER-FREQUENCY
- TC - TRIP COIL

Fig. 11 (K-6375802-1) Typical External Connections for Under-Frequency and Over-Frequency Protection of an A-C Bus Using One Type IJF52A Relay.

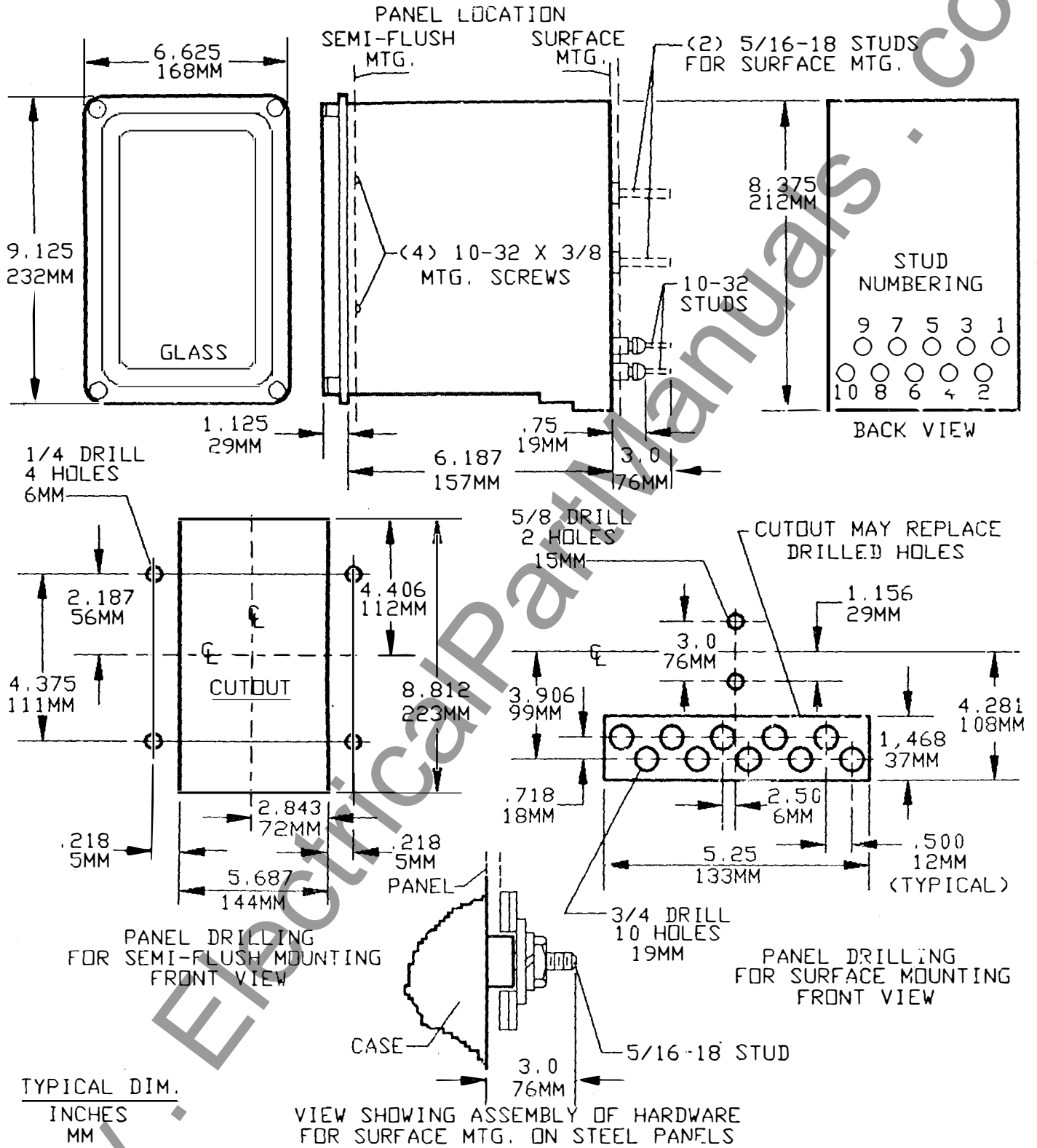

*Fig. 12 (K-6209271 [8]) Outline and Panel Drilling Dimensions for Type IJF Relays

www.ElectricalPartManuals.com

www.ElectricalPartManuals.com



**Meter and Control
Business Department**

ST-3/94 (400)

General Electric Company
205 Great Valley Parkway
Malvern, PA 19355