



**INSTRUCTIONS**

GEI-98302D

DIFFERENTIAL RELAY

TYPE IFD52B

**GENERAL  ELECTRIC**

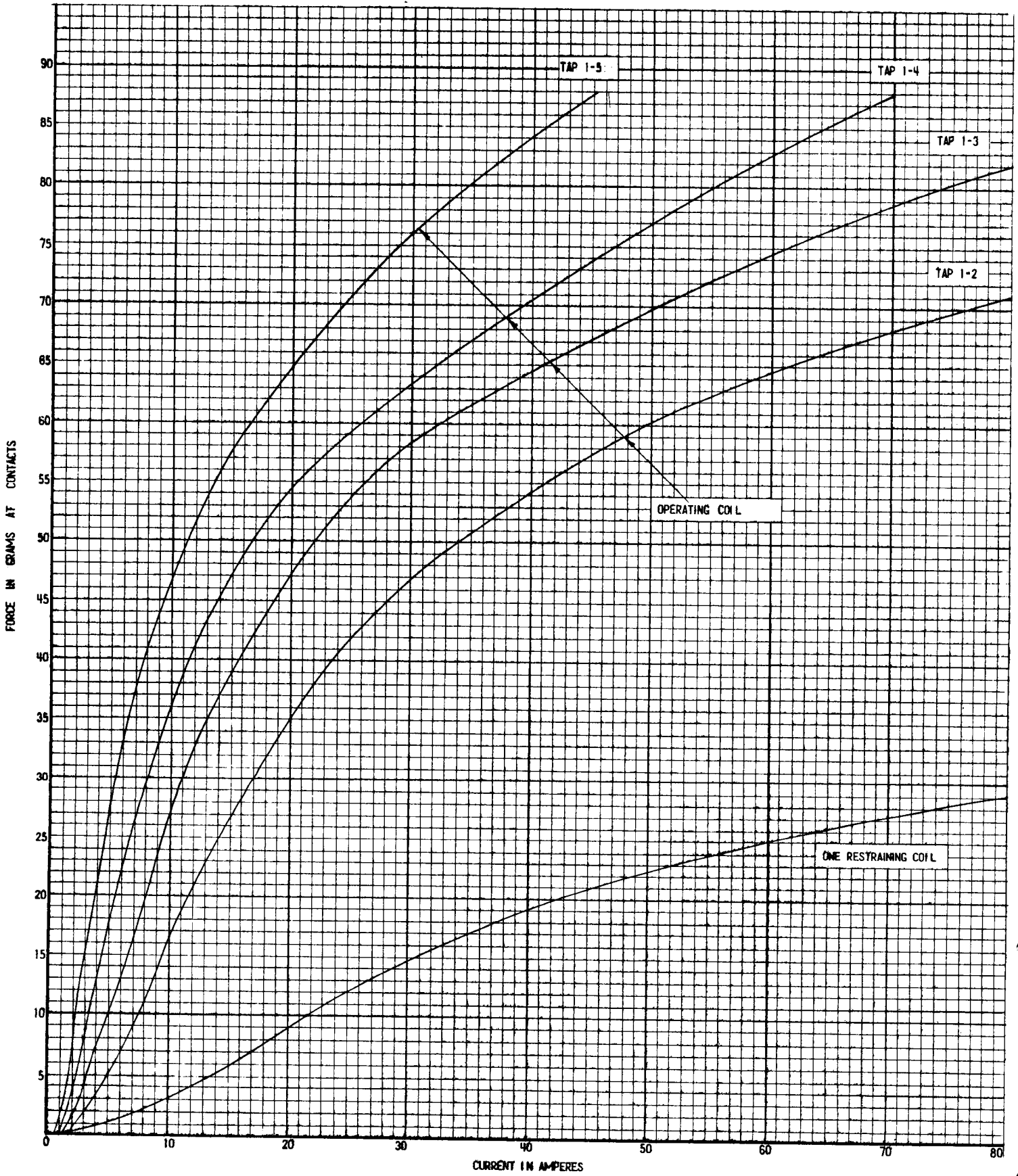

Fig. 2 (237D500-1) Torque Current Curves (60 Cycles) for Type IFD52B Relay

**RATING**

If the 1-2 tap is used this will permit the current transformers to differ 12 amperes when the restraint has 80 amperes. If the 1-5 tap were used only 5 amperes difference would be allowed before false operation would result.

If for an internal fault, 10 amperes were to flow in each restraint coil, then the calculation for the minimum operating current would be as follows:-

A flow of 10 amperes through each of the two coils on one U-magnet is equal to 20 amperes thru one coil. From Fig. 2 we find that 20 amperes through one coil would produce nine grams torque. The total restraint will therefore be three times 9 grams or 27 grams (plus approximately 1/2 gram for the control spring) because all three restraint magnets are producing the same torque for the above conditions. The actual operating current will be the sum of all the restraint currents or 60 amps. The relay will operate for the above internal fault because the 60 amperes through the operating coil will produce 64 grams operating torque and a net torque in the operating direction will therefore be 64 minus 27-1/2 or 36-1/2 grams.

In making these checks, it should be noted that for most conditions one relay will have more restraint than the other, and since the contacts are in series only the one with the greater restraint need be checked.

**CONSTRUCTION**

The components of the IFD52B relay are mounted in a M2 case whose outline and drilling plan is shown in Fig. 5.

The relay components are mounted in a cradle assembly which is latched into a drawout case when the relay is in operation but it can be easily removed when desired. To do this, the relay is first disconnected by removing the connection plug which completes the electrical connections between the case block and the cradle block. To test the relay in its case this connection block can be replaced by a test plug. The cover, which is attached to front of the relay case, contains the target reset mechanism and an interlock arm which prevents the cover from being replaced until the connection plugs have been inserted.

The relay case is suitable for either semi-flush or surface mounting on all panels up to 2 inches thick and appropriate hardware is available. However, panel thickness must be indicated on the relay order to insure that proper hardware will be included.

Every circuit in the drawout case has an auxiliary brush, as shown in Fig. 7, to provide adequate overlap when the connecting plug is withdrawn or inserted. Some circuits are equipped with shorting bars (see Fig. 6) and on these circuits it is especially important that the auxiliary brush makes contact as indicated in Fig. 7 with adequate pressure to prevent the opening of C.T. secondary circuits.

The restraining coil will carry 10 amperes continuously and the operating coil, which is normally de-energized, will carry 5 amperes continuously.

The operating coil (stud 5-6) has a one second rating of 250 amperes.

The restraint coils (studs 7-8, 9-10, 13-14, 15-16, 17-18, 19-20) have a one second rating of 200 amperes.

The instantaneous overcurrent unit (studs 3-4) has a one second rating as given below:

| Unit Rating Amperes | One Second Rating Amperes |
|---------------------|---------------------------|
| 2-8                 | 75                        |
| 4-16                | 150                       |

The autotransformer has a one second rating of 210 amperes on any tap.

The current-closing rating of the contact is 30 amperes for voltages not exceeding 250 volts. The current carrying ratings are affected by the selection of the tap on the target and seal-in coil as indicated in Table A.

**TABLE "A"**

| TARGET AND SEAL-IN UNIT              |           |             |
|--------------------------------------|-----------|-------------|
|                                      | 2 Amp Tap | 0.2 Amp Tap |
| DC Resistance                        | 0.13 Ohms | 7 Ohms      |
| Minimum Operating Carry Continuously | 2.0 Amps  | 0.2 Amps    |
| Carry 30 Amps For                    | 3.0 Amps  | 0.30 Amps   |
| Carry 10 Amps For                    | 4 Secs.   | -----       |
|                                      | 30 Secs.  | 0.2 Secs.   |

The 0.2 ampere tap is for use with trip coils that operate on currents ranging from 0.2 up to 2.0 amperes at the minimum control voltage. If this tap is used with trip coils requiring more than 2 amperes, there is a possibility that the 7 ohm resistance will reduce the current to so low a value that the breaker will not be tripped.

The 2 ampere tap should be used with trip coils that take 2 amperes or more at minimum control voltage, provided the tripping current does not exceed 30 amperes at the maximum control voltage. If the tripping current exceeds 30 amperes an auxiliary relay should be used, the connections being such that the tripping current does not pass through the contact or the target and the seal-in coils of the relay.

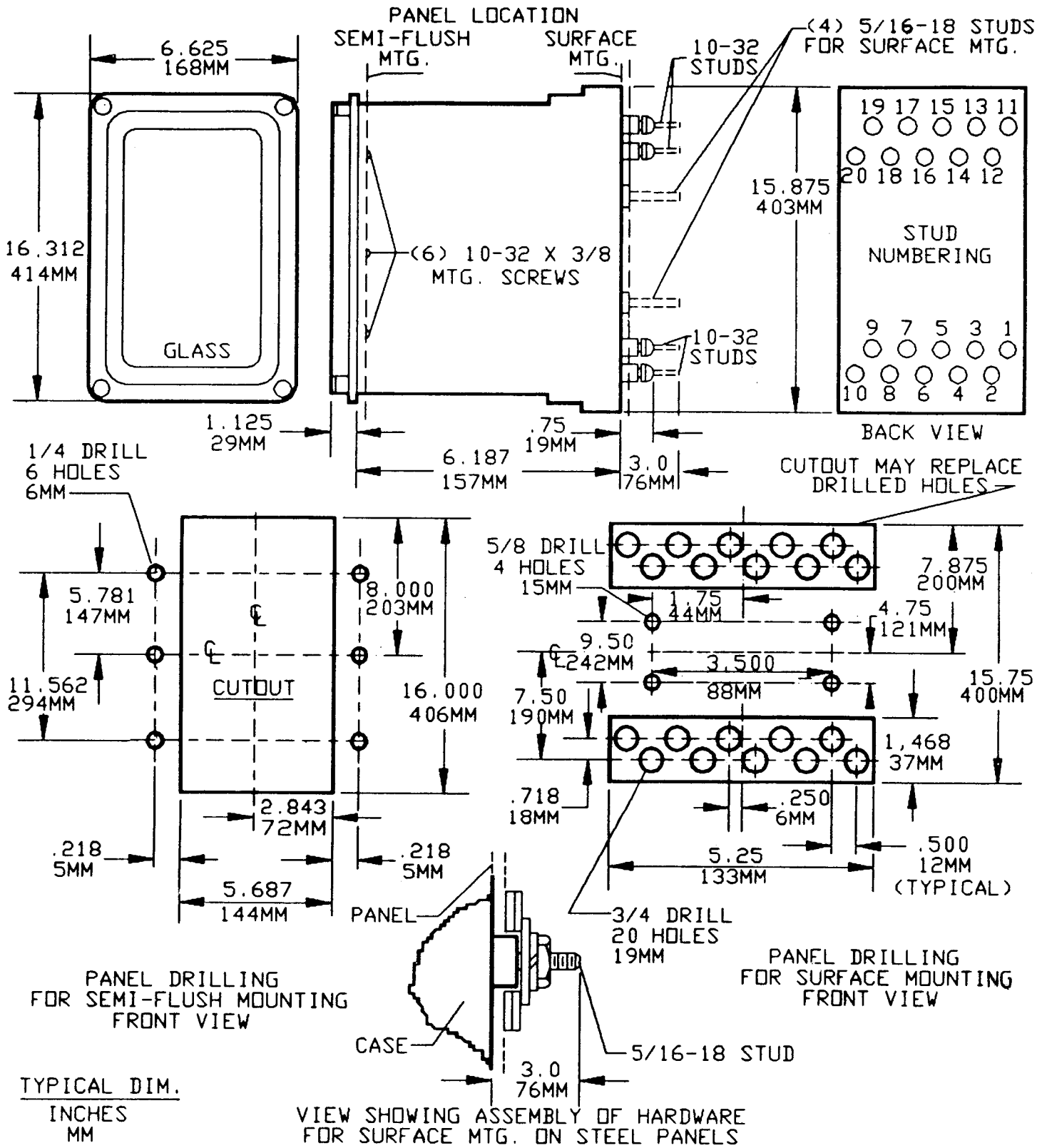

Figure 5 (6209274 [6]) Outline and Panel Drilling for Type IFD52B Relay

## CHARACTERISTICS

The Type IFD52 differential unit has four U-magnets operating on two disks mounted on a common shaft. Three of the U-magnets have two electrically separate restraining coils which drive the disk in the contact-opening direction. The fourth U-magnet has an operating coil which drives the disks in the contact-closing direction.

Under normal operating conditions, the vector sum of the currents flowing through the restraining coils is zero and there is no current flowing through the operating coil. When a fault occurs, the vector sum of the restraining coil currents is not zero and the "difference" or "unbalance" current flows through the primary circuit of the autotransformer. The operating coil which is across the secondary circuit of the autotransformer has a proportional part of this "unbalance" current flowing through it. When the torque produced by the operating coil is greater than the sum of the torques produced by the restraining coils, the relay operates to close its contact.

The relay will operate on 0.4 to 1.4 amperes at zero restraint (minimum pickup) depending upon the tap used on the autotransformer. The minimum operating current can be raised, should unusual operating conditions require it, by increasing the tension of the control spring on the disk shaft.

The spring tension can be increased by turning the control spring adjusting ring in a counter-clockwise direction.

The time-current curves of the relay are shown in Fig. 8. These times apply only for the 1/4 time dial setting. Times may be increased by increasing the time dial setting, but the time dial should never be set below the 1/4 position.

The IFD52B relay contains a shock resistant overcurrent unit whose operating coil is connected in series with the differential unit operating coil. The contact of this overcurrent unit is connected in series with the differential unit contact so that both must be picked up to initiate a tripping signal. This checks that fault current is flowing and guards against false tripping by the differential unit if it should close its contact due to shock.

## BURDENS

The burden of one restraint coil at 5 amperes 60 cycles is 7 volt-amperes and the mutual impedance between two restraint coils on the same core is 0.1 ohm at 5 amperes, 60 cycles.

The burden of the auto-transformer with the operating coil across 1-6 is shown in Fig. 4. There is current in the auto-transformer only during faults and it exerts a burden on the C.T.'s only at that time.

## RECEIVING, HANDLING AND STORAGE

These relays, when not included as a part of a control panel, will be shipped in cartons designed

to protect them against damage. Immediately upon receipt of a relay, examine it for any damage sustained in transit. If injury or damage resulting from rough handling is evident, file a damage claim at once with the transportation company and promptly notify the nearest General Electric Apparatus Sales Office.

Reasonable care should be exercised in unpacking the relay in order that none of the parts are injured or the adjustments disturbed.

If the relays are not to be installed immediately, they should be stored in their original cartons in a place that is free from moisture, dust and metallic chips. Foreign matter collected on the outside of the case may find its way inside when the cover is removed and cause trouble in the operation of the relay.

## ACCEPTANCE TEST

Immediately upon receipt of the relay, an inspection and acceptance test should be made to insure that no damage has been sustained in shipment and that the relay calibrations have not been disturbed.

### Visual Inspection

Check the nameplate stamping to insure that the model number, rating and calibration range of the relay received agree with the requisition.

Remove the relay from its case and check by visual inspection that there are no broken or cracked molded parts or other signs of physical damage, and that all screws are tight. The drag magnet should be fastened securely in position on its mounting shelf. There must not be any metallic particles or other foreign matter in the air gap of any of the U-magnets or the drag magnet.

### Mechanical Tests

1. Manually operate the differential unit and the overcurrent unit and check that both contacts have approximately 1/32 inch wipe.
2. Rotate the differential unit induction disks and check that disks rotate without binding or touching the drag magnet or U-magnets.
3. Operate the target seal-in units and check that they operate without binding.

### Electrical Tests

Connect relay as shown in Fig. 9 and check that the differential unit picks up in the range of values given in Fig. 9 for at least one auto-transformer tap setting. Adjust the DC current to the target seal-in unit tap rating and the target will provide an indication that the differential unit has operated. The relay should be in its case in an upright leveled position during this test.

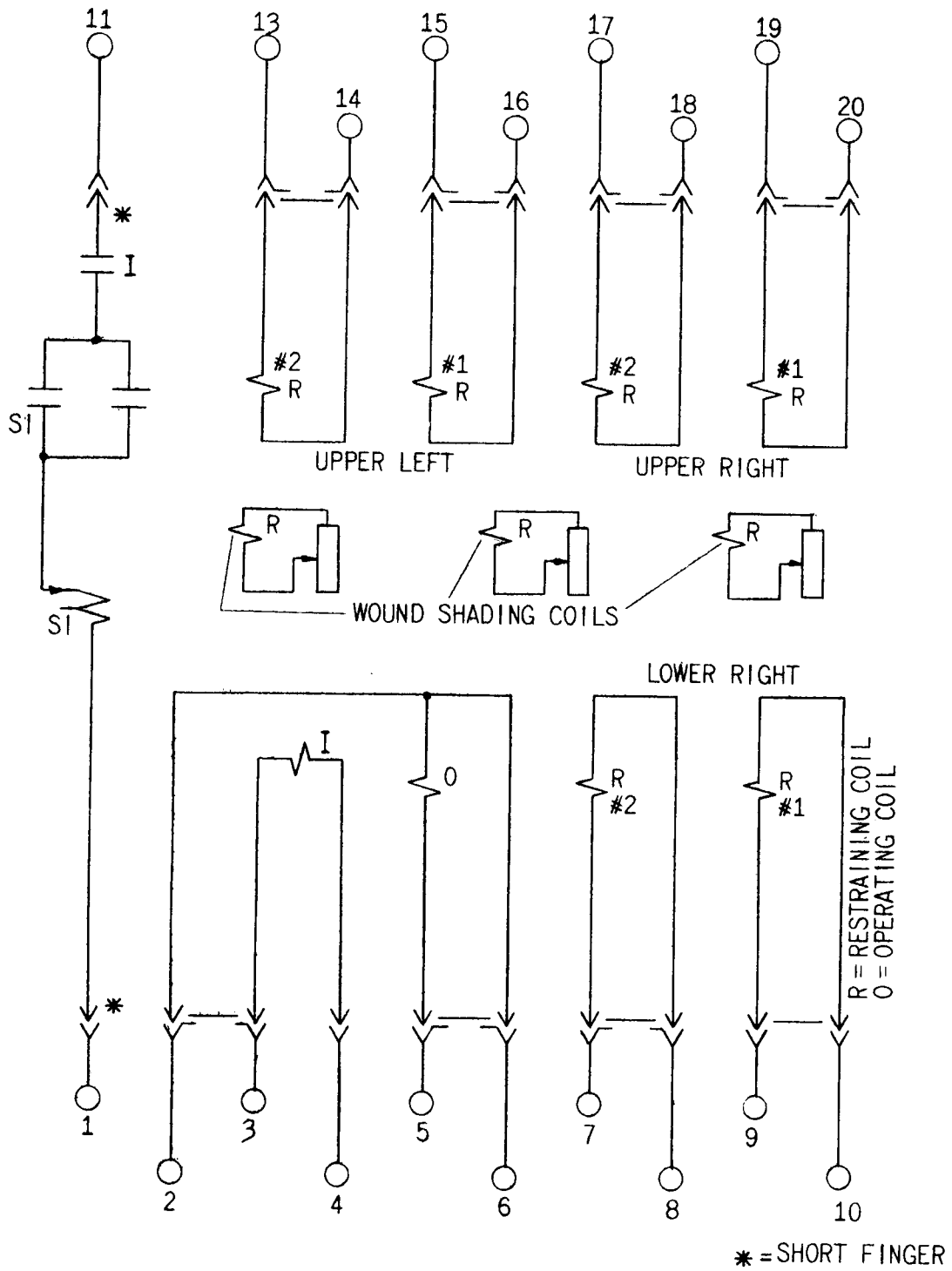

Fig. 6 (0148A3957-0) Internal Connections (Front View) for Type IFD52B Relay

## INSTALLATION PROCEDURE

If after the acceptance tests the relay is held in storage before shipment to the job site, it is recommended that the visual and mechanical inspection described under the section on ACCEPTANCE TESTS be repeated before installation. The relay must be mounted on a vertical surface and must be level for correct operation.

### Electrical Tests

The relay should be mounted in its final location if possible for these tests.

Connect the relay as shown in Fig. 9 and set the relay to pick up at the desired value. Set the time dial at the desired value and check that the pickup time agrees approximately with the values given in Fig. 8 for the settings used. Set the overcurrent unit to pick up at the desired value and check it.

Check that the target seal-in units operate at or below the tap rating used.

If adjustments are necessary, check the section on SERVICING.

### PERIODIC CHECKS AND ROUTINE MAINTENANCE

In view of the vital role of protective relays in the operation of a power system it is important that a periodic test program be followed. It is recognized that the interval between periodic checks will vary depending upon environment, type of relay, and the user's experience with periodic testing. Until the user has accumulated enough experience to select the test interval best suited to his individual requirements it is suggested that the following points be checked at an interval of from one to two years.

1. Repeat the visual and mechanical inspection described under section on ACCEPTANCE TESTS.
2. Repeat the electrical tests described under the section on INSTALLATION PROCEDURE.
3. Check that the contacts are untarnished and in good condition.

### SERVICING

If it is found that the relay calibrations are out of adjustment then proceed as follows:-

1. If there are indications of excessive friction the lower jewel may be tested for cracks by exploring its surface with the point of a fine needle. If it is necessary to replace the jewel a new pivot should be screwed into the bottom

of the shaft at the same time. The jewel should be turned up until the disk is centered in the air gaps, after which it should be locked in this position by the set screw provided for this purpose. The upper bearing pin should next be adjusted until very little end play can be felt; about 0.015 inch is correct.

2. The differential unit pick up can be adjusted by turning the control spring adjusting ring.
3. To change target seal-in tap settings, proceed as follows:-

The tap plug is the screw holding the right-hand stationary contact of the seal-in unit. To change the tap setting, first remove the connection plug. Then, take a screw from the left-hand stationary contact and place it in the desired tap. Next remove the screw from the other tap, and place it in the left-hand contact. This procedure is necessary to prevent the right-hand stationary contact from getting out of adjustment. Screws should not be in both taps at the same time as pickup for d-c will be the higher tap value and a-c pickup will be increased.

4. For cleaning relay contacts a flexible burnishing tool should be used. This consists of an etched roughened strip of flexible metal resembling a superfine file which removes corroded material quickly without scratching the surface. The flexibility of the tool insures the cleaning of the actual points of contact. Never use knives, files, abrasive paper or cloth to clean relay contacts. A burnishing tool as described above can be obtained from the factory.
5. Instantaneous overcurrent unit adjustment. Select the current above which it is desired to have the instantaneous unit operate and set the adjustable pole piece so that the top of hexagon head is even with the desired calibration on the scale. To raise or lower the pole piece, loosen the locknut and turn it up or down and then tighten in position.

### RENEWAL PARTS

It is recommended that sufficient quantities of renewal parts be carried in stock to enable the prompt replacement of any that are worn, broken or damaged.

When ordering renewal parts; address the nearest Sales Office of the General Electric Company, specify quantity required, name of part wanted, and give complete nameplate data. If possible, give the General Electric requisition number on which the relay was furnished.

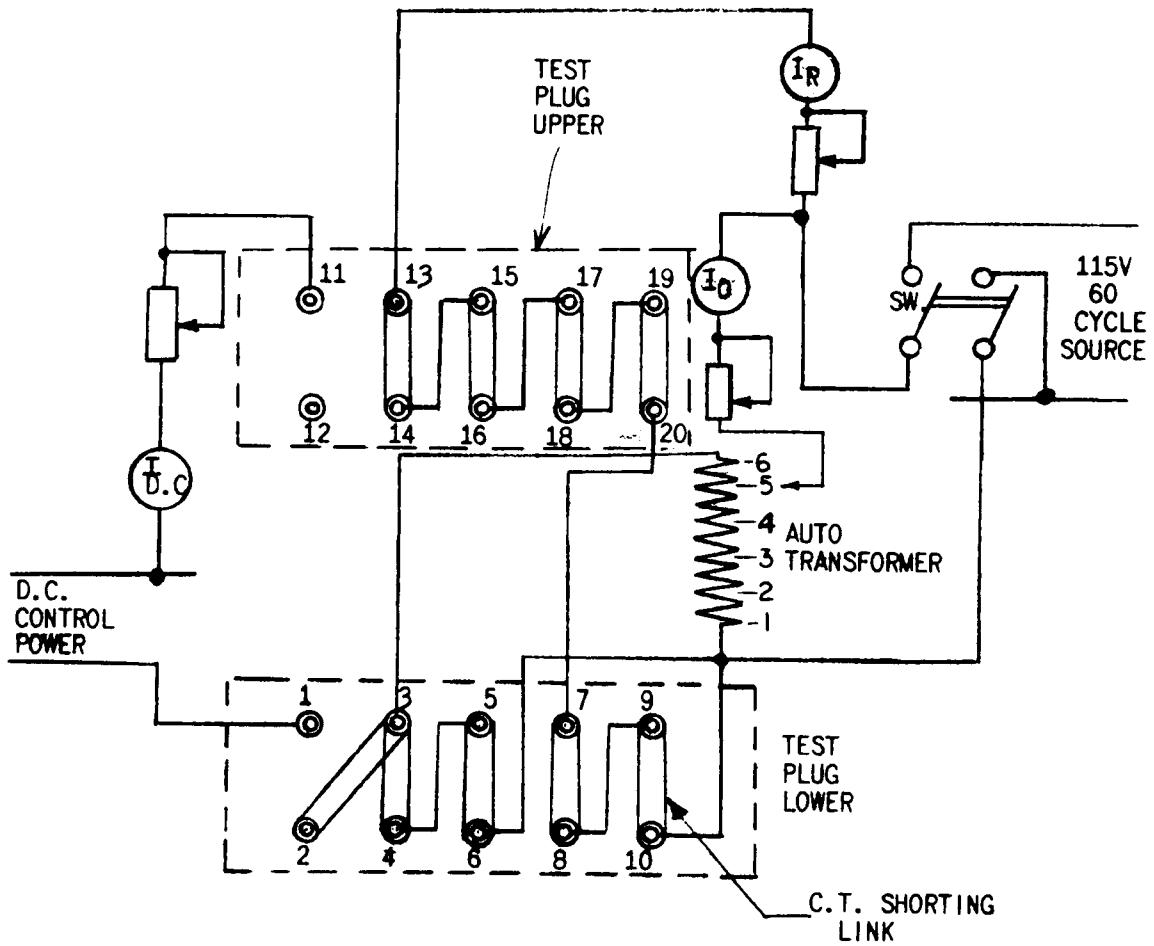

DIFFERENTIAL UNIT WILL JUST CLOSE  
IT'S CONTACT AT THE FOLLOWING VALUES

| AUTO-TRANS.<br>TAP | $I_R$<br>AMPS | $I_0$<br>AMPS |  |
|--------------------|---------------|---------------|--|
| 1-2                | 20            | 45-55         |  |
| 1-3                | 20            | 28-35         |  |
| 1-4                | 20            | 21-26         |  |
| 1-5                | 20            | 13.5-18       |  |

Fig. 9 (0165A7699-1) Field Test Connections for Relay Type IFD52B

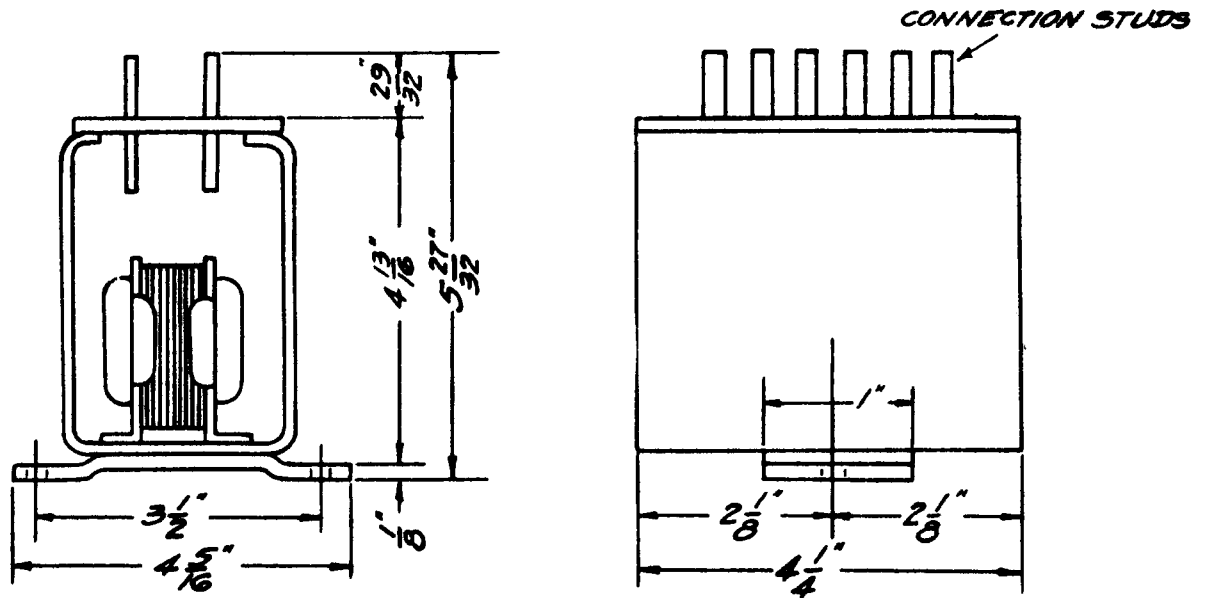

OUTLINE

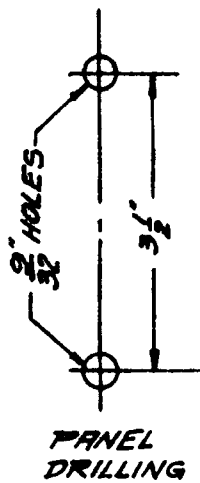

| STUD NO. | AMP RATING       |
|----------|------------------|
| 1        | START OF WINDING |
| 2        | 12.0             |
| 3        | 8.0              |
| 4        | 6.0              |
| 5        | 4.0              |
| 6        | 2.0              |
|          |                  |
|          |                  |
|          |                  |
|          |                  |
|          |                  |
|          |                  |

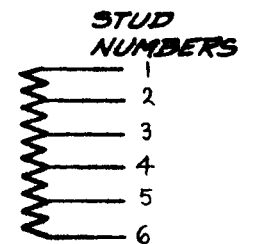

INTERNAL CONNECTIONS

Fig. 10 (6209359-1) Auto-Transformer Outline and Panel Drilling Dimensions

***Meter and Control  
Business Department***

---

11/92 (300)

General Electric Company  
Protection and Control  
205 Great Valley Parkway  
Malvern, Pennsylvania 19355-0715