

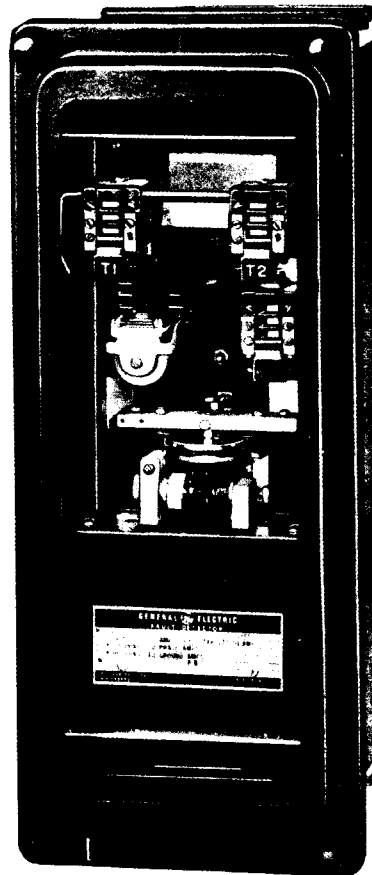

INSTRUCTIONS

GEK-1253D
SUPERSEDES GEK-1253C

FAULT DETECTOR RELAY TYPES CHC11A21 AND UP, CHC11B11 AND UP



GENERAL  ELECTRIC

CONTENTS

	<u>PAGE</u>
INTRODUCTION	3
APPLICATION.	3
PICKUP SETTING DETERMINATION.	4
OPERATING CHARACTERISTICS.	4
RATINGS.	5
BURDENS.	6
INSTALLATION	7
RECEIVING	7
INSPECTION.	7
CAUTION.	7
SETTINGS.	7
CUP UNIT (PFD)	7
HINGED ARMATURE UNIT (GFD)	7
TARGET UNITS (T1 and T2)	8
AUXILIARY RELAY (A).	8
LOCATION AND MOUNTING	8
CONNECTIONS	8
MAINTENANCE.	8
PERIODIC TESTING.	8
SERVICING	8
CONTACT CLEANING	8
BEARINGS	9
RECALIBRATION	9
CUP UNIT (PFD)	9
HINGED ARMATURE UNIT (GFD)	10
AUXILIARY RELAY (A).	10
RENEWAL PARTS	10

FAULT DETECTOR RELAYS
TYPES CHC11A21 AND UP, CHC11B11 AND UPINTRODUCTION

The CHC11A relay is a complete three-phase and ground, multicontact, high speed nondirectional over-current relay. The relay consists of an induction cup unit for multiphase faults and a small hinged armature unit for ground faults. Two targets and four electrically separate contacts are available and the stud arrangement is such that complete flexibility of application is obtainable. These units are identified in Fig. 1 by nomenclature used throughout the text. Within its current-carrying capability, the induction cup unit of THE CHC11A RELAY IS DESIGNED FOR CONTINUOUS OPERATION IN THE PICKED UP POSITION.

The CHC11B is similar to the CHC11A except that it has a dual rated auxiliary telephone relay "A" unit. The desired rating is selected by a toggle switch mounted on the front of the relay.

APPLICATION

The CHC11A relay may be applied wherever a high-speed fault detector is required. However, because it has four electrically separate contacts and can be operated continuously in the picked up position, it is particularly well suited for applications as a fault selector in circuit breaker failure back-up schemes. In these schemes, the CHC11A relay is used to detect the failed circuit breaker and to select the back-up breakers to be tripped in order to isolate the fault.

In general, the cup unit or phase fault detector (PFD) would be used to detect three-phase, phase-to-phase and double phase-to-ground faults while the hinged armature or ground fault detector (GFD) unit would detect single phase-to-ground faults if desired. In this respect, the hinged armature unit is more sensitive than the cup unit. Typical external connections for the CHC11A relay are shown in Fig. 10.

When using the CHC11A relay in circuit breaker failure back-up schemes, the relay may be called on to carry maximum fault current for some fraction of a second before the fault is cleared. For this reason, the short time current capability of the relay should be noted. This is particularly true of the hinged armature unit. Fig. 2 gives the capability of this unit from 0.1 to 1.0 second. The short time rating of the cup unit is so high that it will probably never be a limiting factor.

While the 2-8 ampere cup unit is continuously rated for five amperes, it is capable of carrying eight amperes continuously. This is important in multibreaker bus arrangements where bus current, which the relay may be connected to receive, can exceed five amperes during maximum load conditions.

In a circuit breaker failure scheme, the DC supply for the internal auxiliary of the CHC11A must not be taken through the same fuses from which the associated circuit breaker obtains its tripping current.

Pickup and dropout time curves for the two units are given under OPERATING CHARACTERISTICS. It is important to note that these curves represent maximum times and that dropout time is the time to open the normally open contacts.

These instructions do not purport to cover all details or variations in equipment nor to provide for every possible contingency to be met in connection with installation, operation or maintenance. Should further information be desired or should particular problems arise which are not covered sufficiently for the purchaser's purposes, the matter should be referred to the General Electric Company.

To the extent required the products described herein meet applicable ANSI, IEEE and NEMA standards; but no such assurance is given with respect to local codes and ordinances because they vary greatly.

PICKUP SETTING DETERMINATION

The cup unit (PFD) develops torque which is related to the phase currents in the following way.

$$\text{Torque} = K (I_1^2 + I_2^2 + I_3^2)$$

where K is a constant.

If the unit is set to pick up at 3.0 amperes, phase-to-phase, the torque is

$$T = K (3^2 + 3^2) = 18K$$

In order to develop the same pickup torque for a balanced three-phase fault

$$T = 18K = K (I^2 + I^2 + I^2)$$

$$3 I^2 = 18$$

$$I = \frac{3 \sqrt{2}}{\sqrt{3}} = 2.45 \text{ amperes.}$$

Thus if the relay is adjusted to pick up for a three ampere phase-to-phase fault, it will pick up for a three-phase fault of 2.44 amperes. The balanced three-phase pickup is $\sqrt{2} / \sqrt{3}$ or 0.817 times the phase-to-phase pickup.

The cup unit will also operate with current in only one phase. With a three ampere phase-to-phase pickup setting the single phase current required to operate the unit is determined as follows:

$$T = 18K = K (I^2)$$

$$I^2 = 18$$

$$I = 3 \sqrt{2} = 4.24 \text{ amperes}$$

The single phase pickup current is $\sqrt{2}$ or 1.414 times the phase-to-phase pickup.

From the above it is apparent that the cup unit (PFD) can detect single phase-to-ground faults as well as multiphase faults if the fault current is large enough.

When the CHC11A relay is used as a fault detector, the cup unit should be set so that the minimum phase-to-phase fault current exceeds 1.5 times the phase-to-phase pickup. This will insure pickup for all multiphase faults. If the minimum single phase fault current is sufficient to operate the unit for this setting, it is not necessary to use the hinged armature (GFD) unit. However, the GFD unit may be used for single phase-to-ground faults if desired.

The hinged armature unit is connected in the current transformer circuit to receive three times the zero sequence current. It should be set so that $3 I_0$ for minimum fault conditions exceeds 1.5 times pickup of this unit.

* An external reactor is included with the relay for connection across the GFD operating circuit (see Fig. 11). The purpose of this reactor is to reduce the dropout delay which may result from the delay of energy in the CT core after the primary current has been interrupted.

OPERATING CHARACTERISTICS

Table I lists the operating ranges for the cup (PFD) unit of CHC11A relay. These ranges depend upon the type of fault experienced by the relay. See the application section for details why these pickup ranges vary with the type of fault.

*Indicates revision

TABLE I

TYPE OF FAULT	PICKUP RANGE OF CUP UNIT - AMPERES			
	1-4	2-8	4-16	20-80
Phase-to-Phase	1-4	2-8	4-16	20-80
Three Phase	0.815-3.76	1.63-6.52	3.26-13.0	16.3-65.2
Single Phase to Ground	1.415-5.65	2.83-11.3	5.66-22.6	28.3-113

The short time current capability curve for the hinged armature (GFD) unit is shown in Fig. 2.

The maximum pickup time-current characteristics of the cup unit plus auxiliary telephone unit are shown in Fig. 3. The pickup time is dependent on the pickup setting of this unit. The maximum dropout time-current characteristic for the cup unit plus auxiliary telephone unit is shown in Fig. 4. This curve applies to all pickup settings of this unit. The maximum pickup and dropout time-current characteristics of the hinged armature unit plus the auxiliary telephone unit are shown in Figs. 5 and 6, respectively. These curves apply to all pickup settings of this unit.

Maximum pickup time is the total time required for the cup or hinged armature unit to close its contacts plus the time for a normally open contact of the auxiliary telephone unit to close. The maximum dropout time is the total time required for the cup or hinged armature unit to open its contacts plus the time required to open a normally open contact of the auxiliary telephone unit when the current is suddenly reduced to zero.

RATINGS

The continuously adjustable pickup ranges, continuous and the one-second thermal ratings for the overcurrent units are listed in Table II.

TABLE II

UNIT	PICKUP RANGE	CONTINUOUS RATING - AMPERES	ONE SECOND RATING - AMPS
PFD	1-4	4	150
	2-8	8	290
	4-16	16	290
	20-80	20	325
GFD	0.5-2	0.65	18
	1-4	1.5	36
	2-8	3	72
	4-16	6	140
	10-40	10	290
	20-80	20	400

The auxiliary telephone relay is continuously rated at the nameplate DC voltage. The contact interrupting capabilities are shown in Table III.

TABLE III
Telephone Relay Contact

VOLTS	AMPS INDUCTIVE**
480	1.0
115	1.0
240	1.0

**Indicates rating for a 100ms trip coil
The inductive ratings are approximately
50% of the ratings shown.

*Indicates revision

The contacts of the cup unit and the hinged armature unit are capable of interrupting the auxiliary telephone unit current.

* The current-closing rating of the contacts is 30 amperes for voltages not exceeding 250 volts. current-carrying ratings are affected by the selection of the tap on the target and seal-in coil as indicated in the following table:

TABLE IV

	DUAL RATED			
	0.2/2.0		0.6/2.0	
	0.2	2.0	0.6	2.0
Carry 30 amps for (sec)	0.05	2.2	0.5	3.5
Carry 10 amps for (sec)	0.45	20	5.0	30
Carry continuously (amp)	0.37	2.3	1.2	2.6
Minimum operating (amp)	0.2	2.0	0.6	2.0
Minimum dropout (amp)	0.05	0.5	0.15	0.5
DC resistance (ohms)	8.3	0.24	0.78	0.18
60 hertz impedance (ohms)	50	0.65	6.2	0.65
50 hertz impedance (ohms)	42	0.54	5.1	0.54

If the tripping current exceeds 30 amperes, an auxiliary relay should be used, the connections being such that the tripping current does not pass through the contacts or the target and seal-in coils of the protective relay.

BURDENS

The 60 cycle burden per phase of the cup (PFD) unit with 5.0 amperes flowing in each phase is listed in Table V.

TABLE V
Burden of PFD Unit

RANGE	VOLT-AMPS AT 5 AMPS	IMPEDANCE	POWER FACTOR LAG
1-4	20	0.8	0.5
2-8	5	0.2	0.5
4-16	1.25	0.05	0.5
20-80	0.05	0.002	0.5

Table VI lists the 60 cycle burdens of the hinged armature (GFD) unit. These burdens were determined with the unit set at its minimum pickup value.

TABLE VI
Burdens of GFD Unit

RANGE	AT MIN. P.U. CURRENT			AT 5 AMPERES		
	Z	PF	VA	Z	PF	VA
0.5-1	11.8	0.77	2.95	7.6	0.79	19.0
1-4	3.95	0.77	2.95	1.9	0.79	47.5
2-8	1.74	0.77	2.95	0.5	0.79	11.9
4-16	0.20	0.77	2.95	0.20	0.79	5.0
10-40	0.033	0.77	2.95	0.033	0.79	0.83
20-80	0.008	0.77	2.95	0.008	0.79	0.21

*Indicates revision

INSTALLATIONRECEIVING

These relays, when not included as a part of a control panel, will be shipped in cartons designed to protect them against damage. Immediately upon receipt of the relay, an examination should be made for any damage sustained during shipment. If injury or damage resulting from rough handling is evident, a claim should be filed at once with the transportation company and the nearest Sales Office of the General Electric Company notified promptly.

Reasonable care should be exercised in unpacking the relay in order that none of the parts are injured or the adjustments disturbed.

If the relays are not to be installed immediately, they should be stored in their original cartons in a place that is free from moisture, dust, and metallic chips. Foreign matter collected on the outside of the case may find its way inside when the cover is removed and cause trouble in the operation of the relay.

* Note that an external reactor is furnished with this relay. The two leads from the reactor should be connected to studs 14 and 15 as shown in Fig. 11.

INSPECTION

At the time of installation, the relay should be inspected for tarnished contacts, loose screws, or other imperfections. The endplay of the cup unit shaft assembly should be 0.016 inch. These should be corrected (if necessary) before the relay is put into service.

Caution

Every circuit in the drawout case has an auxiliary brush. It is especially important on current circuits and other circuits with shorting bars that the auxiliary brush be bent high enough to engage the connecting plug or test plug before the main brushes do. This will prevent CT secondary circuits from being opened. See Fig. 7.

SETTINGSCup Unit (PFD)

The CHC11A relay has been tested at the factory. The pickup of the cup (PFD) unit has been set at 2.0 amperes phase-to-phase. This pickup may be set at a higher value by loosening the hexagonal control spring locking screw and rotating the control spring adjuster in a counterclockwise direction until the desired phase-to-phase pickup is obtained. It is only necessary to set pickup for one pair of phases. Fig. 8A shows the connections necessary to do this. After the pickup has been set be sure to tighten the hexagonal lock screw.

Hinged Armature Unit (GFD)

When the relay was tested at the factory, the pickup of the hinged armature unit was set at its minimum value; i.e., the top of the hexagonal adjustable core was lined up with the lowest calibration mark. The pickup current levels for this unit are stamped beside each calibration mark.

To increase the current at which the hinged armature unit picks up, loosen the locking nut and then rotate the adjustable core in a counterclockwise direction. After the top of the hexagonal head core is at the desired calibration mark, the final core adjustment may be made using the test connections shown in Fig. 8B. Tighten the locking nut, being sure not to turn the adjustable core.

* If the external reactor supplied with the relay is used as shown in Fig. 11, the pickup of the GFD unit will be approximately 40 percent higher than indicated by the calibration points marked at the factory.

*Indicates revision

Target Units (T1 and T2)

The electrically operated target units have two taps, 0.2 and 2.0 amperes. The relay is shipped with the tap screws in the 2.0 ampere tap. The applicable tap must be selected and the tap screw placed in that tap. Tap screws should not be in both taps at the same time.

Auxiliary Relay (A)

Connected from the auxiliary relay contacts to either terminal 19 or 20, is a red jumper lead. This lead can be connected to either terminal to obtain a normally open or a normally closed contact. As shipped from the factory, the red lead is connected to terminal 19 to give a normally open contact between terminals 19 and 20.

LOCATION AND MOUNTING

The location should be clean and dry, free from dust and, excessive, vibration, and well lighted to facilitate inspection and testing.

The relay should be mounted on a vertical surface. The outline and panel drilling diagram is shown in Fig. 11.

Unless mounted on a steel panel which adequately grounds the relay case, it is recommended that the case be grounded through a mounting stud or screw with a conductor not less than #12 B&S gage copper wire or its equivalent.

CONNECTIONS

The internal wiring diagram for the CHC11A and CHC11B relays are shown in Figs. 9 and 10. A typical external wiring diagram is shown in Fig. 11.

MAINTENANCEPERIODIC TESTING

It is recommended that a mechanical inspection and an operational test be performed at least annually and if possible at the same time associated equipment is tested.

The interval of time may vary depending on the relative importance of individual protective equipment, and the exposure to unfavorable conditions, such as extreme heat, moisture or fumes. Dust and dirt may contaminate the relay when the protective cover is removed.

Periodic tests consist of checking: the contacts for corrosion and pitting; the bearings for dust and dirt; the relay calibration.

SERVICINGContact Cleaning

For cleaning fine silver contacts, a flexible burnishing tool should be used. This consists of a flexible strip of metal with an etched roughened surface, resembling in effect a superfine file. The polishing action is so delicate that no scratches are left, yet corroded material will be removed rapidly and thoroughly. The flexibility of the tool insures the cleaning of the actual points of contact.

Fine silver contacts should not be cleaned with knives, files or abrasive paper. Knives or files may leave scratches which increase arcing and deterioration of the contacts. Abrasive paper or cloth may leave minute particles of insulating abrasive material in the contacts, thus preventing closing.

The burnishing tool described above is included in the XRT relay tool kit which is obtainable from the factory.

Bearings

The lower jewel of the cup unit should be checked for dust and dirt. If necessary, clean but do not put any type of oil on this bearing. When finished, be sure to tighten the set screw, observing that the cup unit shaft endplay is 0.016 inch.

RECALIBRATION

The relays are adjusted at the factory, and it is advisable not to disturb the adjustments except for the changes covered in the SETTINGS section. If for any reason the adjustments have been disturbed, the following points should be observed in restoring them.

Cup Unit (PFD)

1. The contact gap of this unit is 0.020 inch. To obtain this gap the following procedure is recommended.
 - a. Advance the right stop screw until the moving contact arm is parallel to the sides of the cup unit.
 - b. Advance the stationary contact until it just touches the moving contact. A neon lamp connected across terminals 9 and 10 is best suited for this purpose.
 - c. Tighten the clamping screw so that the stationary contact is secure.
 - d. Back the right stop screw until the measured gap of 0.020 inch exists between the moving and the stationary contact. (It should be noted that 0.020 inch corresponds to approximately two-thirds of a turn of the stop screw.)
 - e. Tighten the locknut so as to clamp the stop screw in this position, being careful not to disturb the contact gap adjustment.
2. With the connections of Fig. 8A, and rated voltage across studs 9 and 10, set the current of the cup unit at the minimum pickup value and adjust the control spring as described under SETTINGS to obtain pickup. Pickup of the fault detector will operate the auxiliary telephone relay. The telephone relay current passing through the holding coil prevents the PFD contacts from arcing just at pickup. This holding action also tends to prevent contact bounce, as can be detected if the telephone relay chatters at higher levels of operating currents.

The holding coil force is controlled by the air gap between the holding coil pole pieces and the armature on the moving assembly and the level of currents as controlled by the R-1 adjustable resistor mounted at the rear of the relay.

The factory settings of the holding coil force is determined by the dropout value of the phase fault detector. The relays are set to drop out between 50 to 90 percent of pickup when the pickup is at the lower end of the adjustable range. If readjustment is required do not set R-1 less than 80 percent maximum resistance in the interest of not exceeding its watt rating.

When the holding coil adjustment is made, the holding coil air gap must be at least 0.015 inch when the PFD contacts are closed and fully wiped in.

3. The pickup of the cup unit may be changed in the manner described under SETTINGS.

4. With the connections of Fig. 8A, the clutch should be adjusted to slip at 10 to 12 times minimum pickup current. The clutch slipping point may be changed by turning the clutch adjusting screw. Turning the screw clockwise will cause the clutch to slip at a higher value of current. Be sure to tighten the locking nut, being careful not to disturb the clutch.

Hinged Armature Unit (GFD)

1. Both contacts should close at the same time with approximately 1/32 inch wipe. When fully wiped in; at least 3/4 of each contact surface should be engaged.
2. When checking the calibration of this unit make sure the top surface of the adjustable core is lined up with the calibration mark being checked. At each calibration mark the unit should pick up within plus or minus ten percent of the particular current being checked.
3. The pickup of the hinged armature unit may be changed in the manner described under SETTINGS.

Auxiliary Relay (A)

1. Mechanical Adjustments

- a. There should be at least 1/32 inch clearance between the armature and the pole piece.
- b. The normally open contacts should have a gap of 0.015 inch and the normally closed contacts should have at least 15 grams pressure as measured at the contact tip. The normally open contacts should close with at least 0.005 inch wipe. The normally closed contacts should open to a gap of 0.015 inch.
- c. All normally open contacts should make at approximately the same time.
- d. The residual screw should be adjusted to give a 0.002 inch gap between the pole piece and the armature.

2. Electrical Tests

- a. With DC voltage applied to relay terminals 9 and 10 and the cup unit contacts blocked closed, the A relay should pick up at 80 percent or less of the CHC11A rated DC voltage. The dropout voltage should be 50 percent or less of the rated DC voltage.
- b. With rated DC voltage applied to relay terminals 9 and 10 and the cup unit contacts blocked closed, the pickup and dropout time should be eight milliseconds or less.

NOTE: Pickup time is the time required to close a normally open contact from the instant rated voltage is applied to the A relay. Dropout time is the time required to open a normally open contact from the instant rated voltage is removed.

RENEWAL PARTS

It is recommended that sufficient quantities of renewal parts be carried in stock to enable the prompt replacement of any that are worn, broken, or damaged.

When ordering renewal parts, address the nearest Sales Office of the General Electric Co., specify quantity required, name of part wanted, and give complete nameplate data.

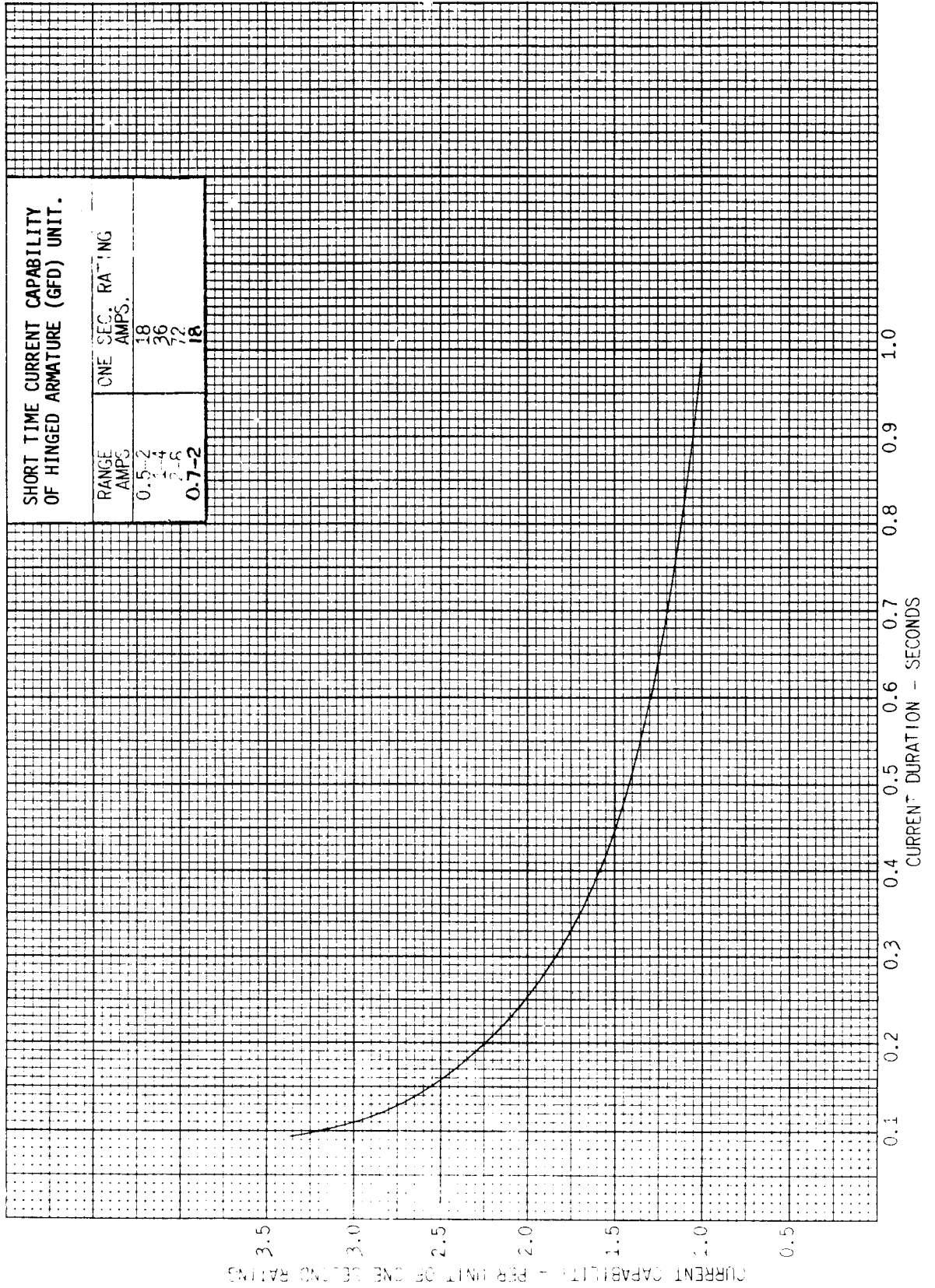

Fig. 2 (0127A7901-2) Time-current Capability Characteristic of GFD Unit

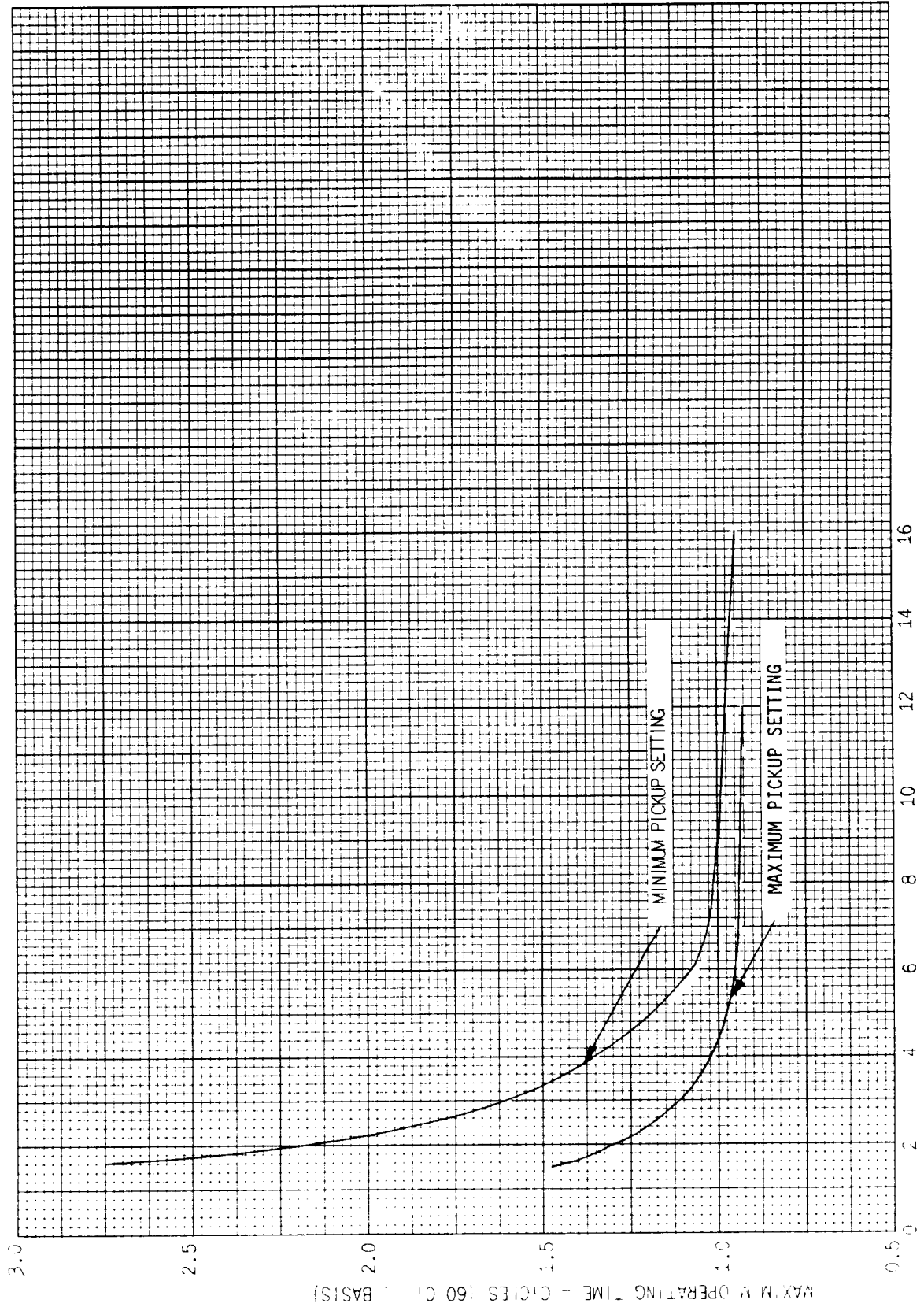

Fig. 3 (G127A9438-0 Sh. 4) Maximum Pickup Time Curves for Cup (PFD) Unit Plus Telephone Unit (A) of CHC11A Relay

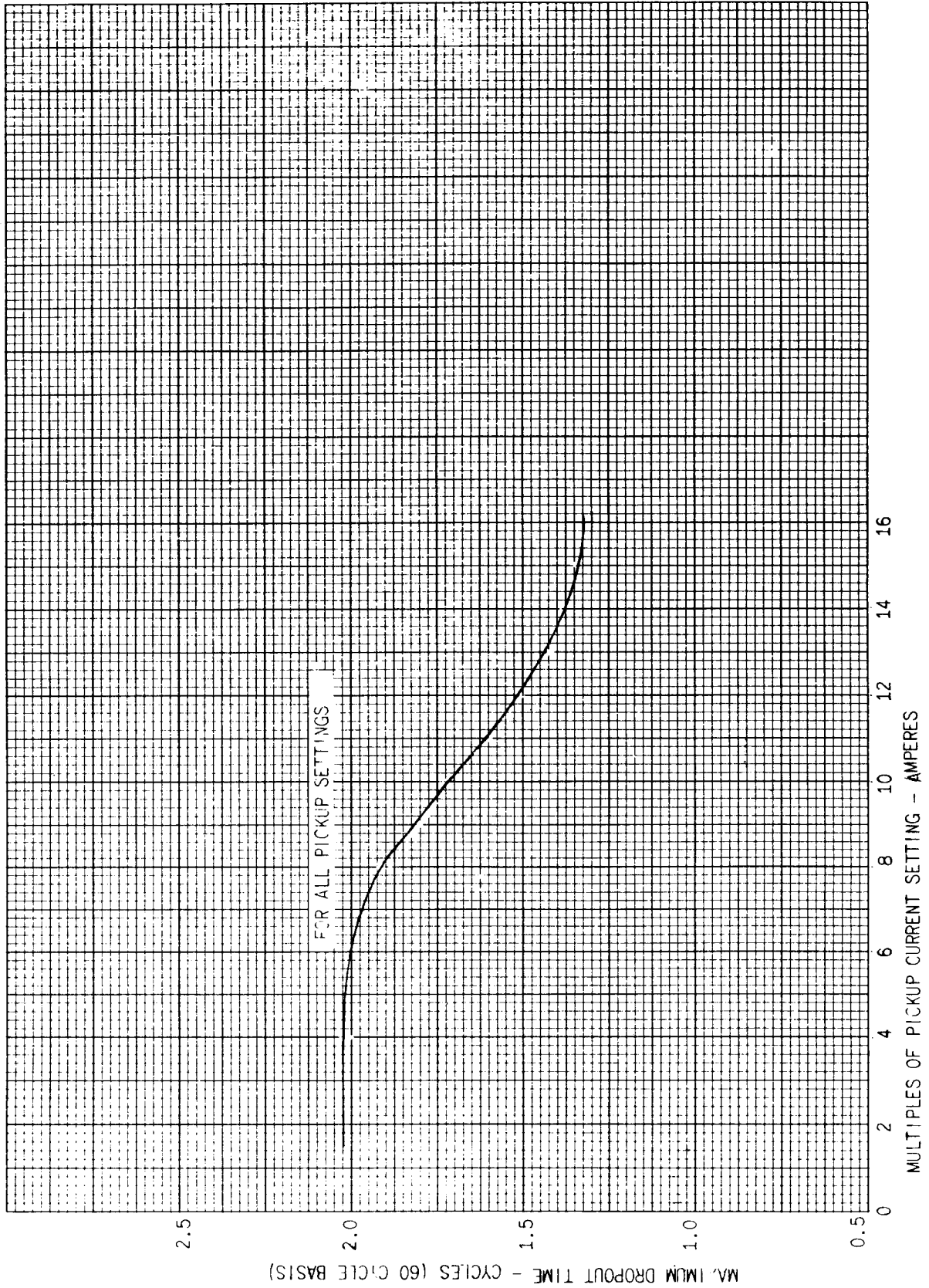

Fig. 4 (0127A9438-0 Sh. 3) Maximum Dropout Time Curve for Cup (PFD) Unit Plus Telephone Unit (A) of CHC11A Relay

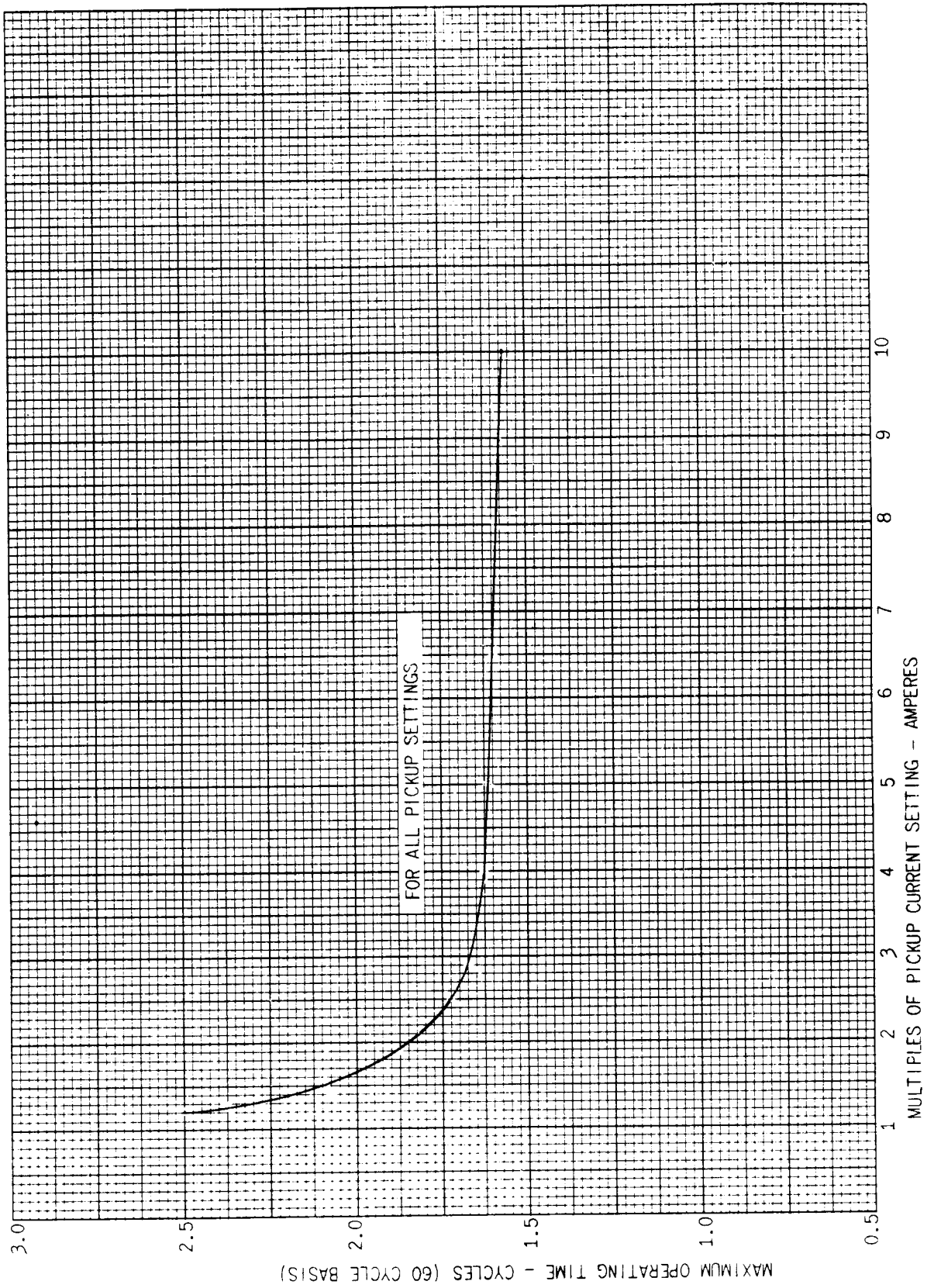

Fig. 5 (0127A9438-0 Sh. 1) Maximum Pickup Time Curve for Hinged Armature (GFD) Unit Plus Telephone Unit (A) of CHC11A Relay

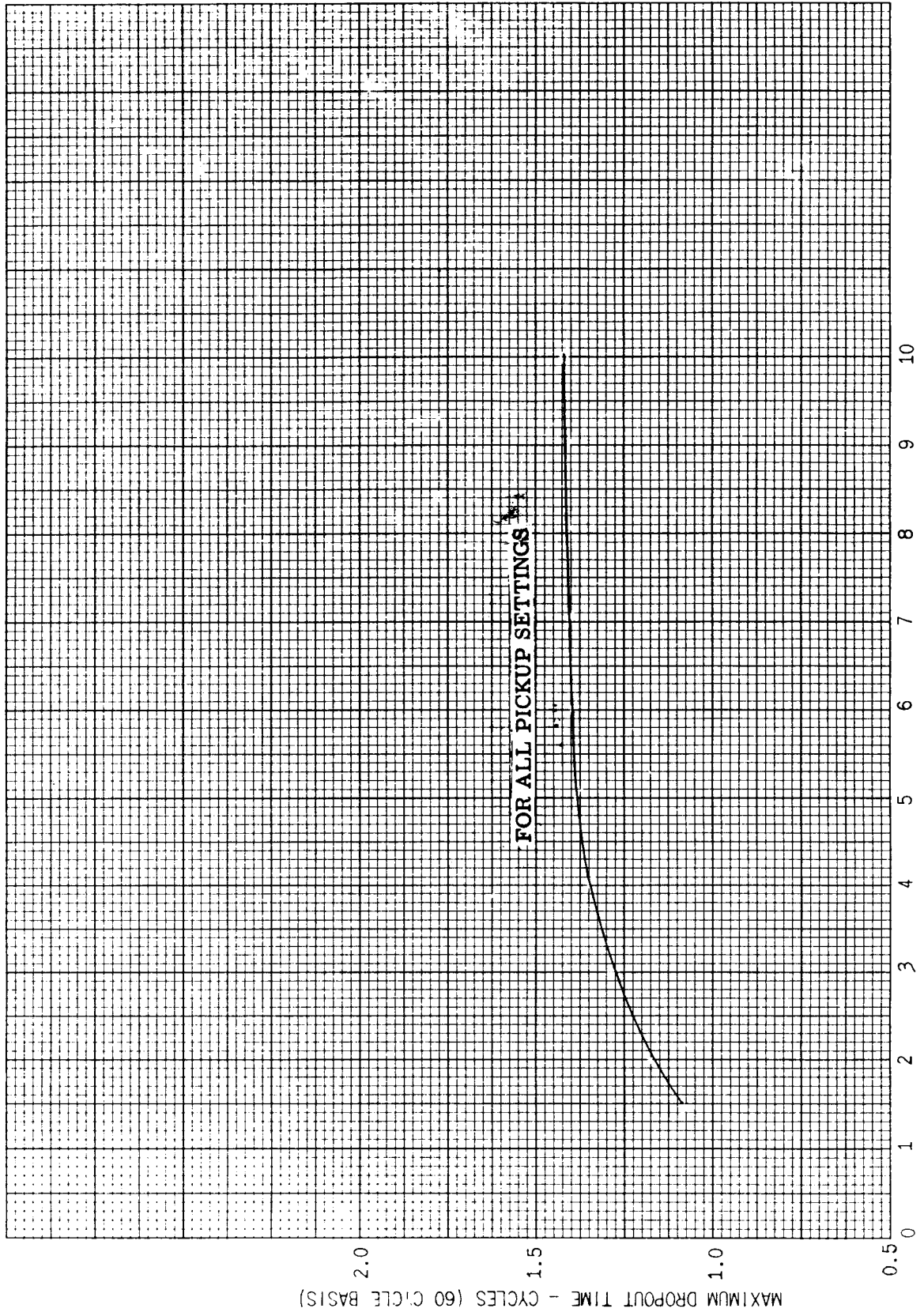
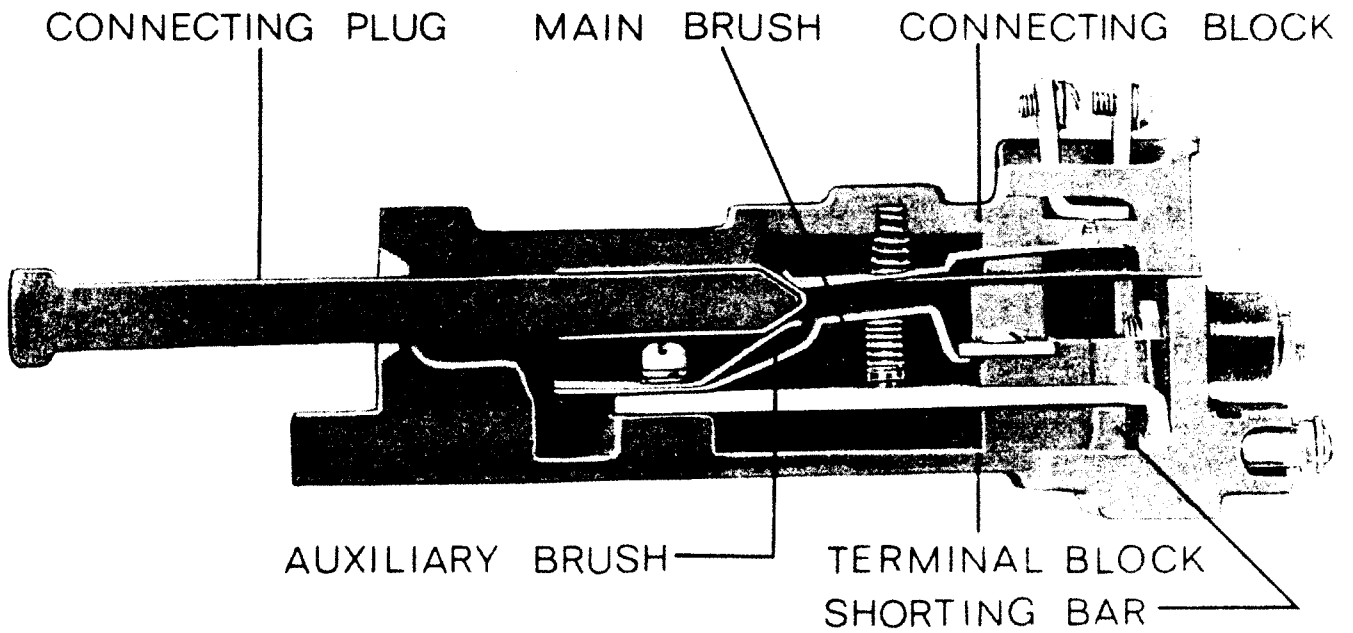
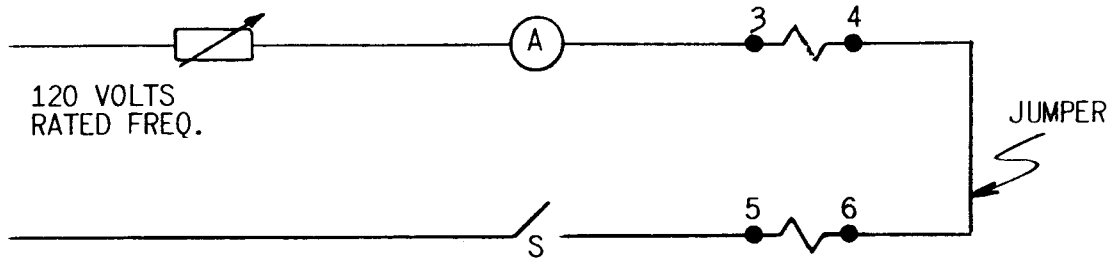

Fig. 6 (0127A9438-0 Sh. 2) Maximum Dropout Time Curve for Hinged Armature (GFD) Unit Plus Telephone Unit of CHC11A Relay



NOTE: AFTER ENGAGING AUXILIARY BRUSH CONNECTING PLUG TRAVELS $\frac{1}{4}$ INCH BEFORE ENGAGING THE MAIN BRUSH ON THE TERMINAL BLOCK

Fig. 7 (8025039) Cross Section of the Connecting Plug Showing Position of Auxiliary Brush



A. CONNECTIONS FOR SETTING PICKUP OF CUP (PFD) UNIT

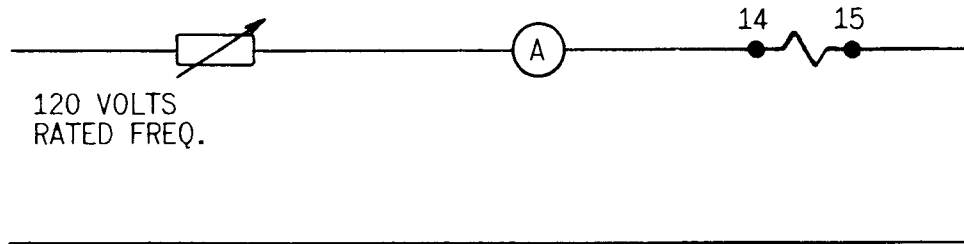

B. CONNECTIONS FOR SETTING PICKUP OF HINGED ARMATURE (GFD) UNIT

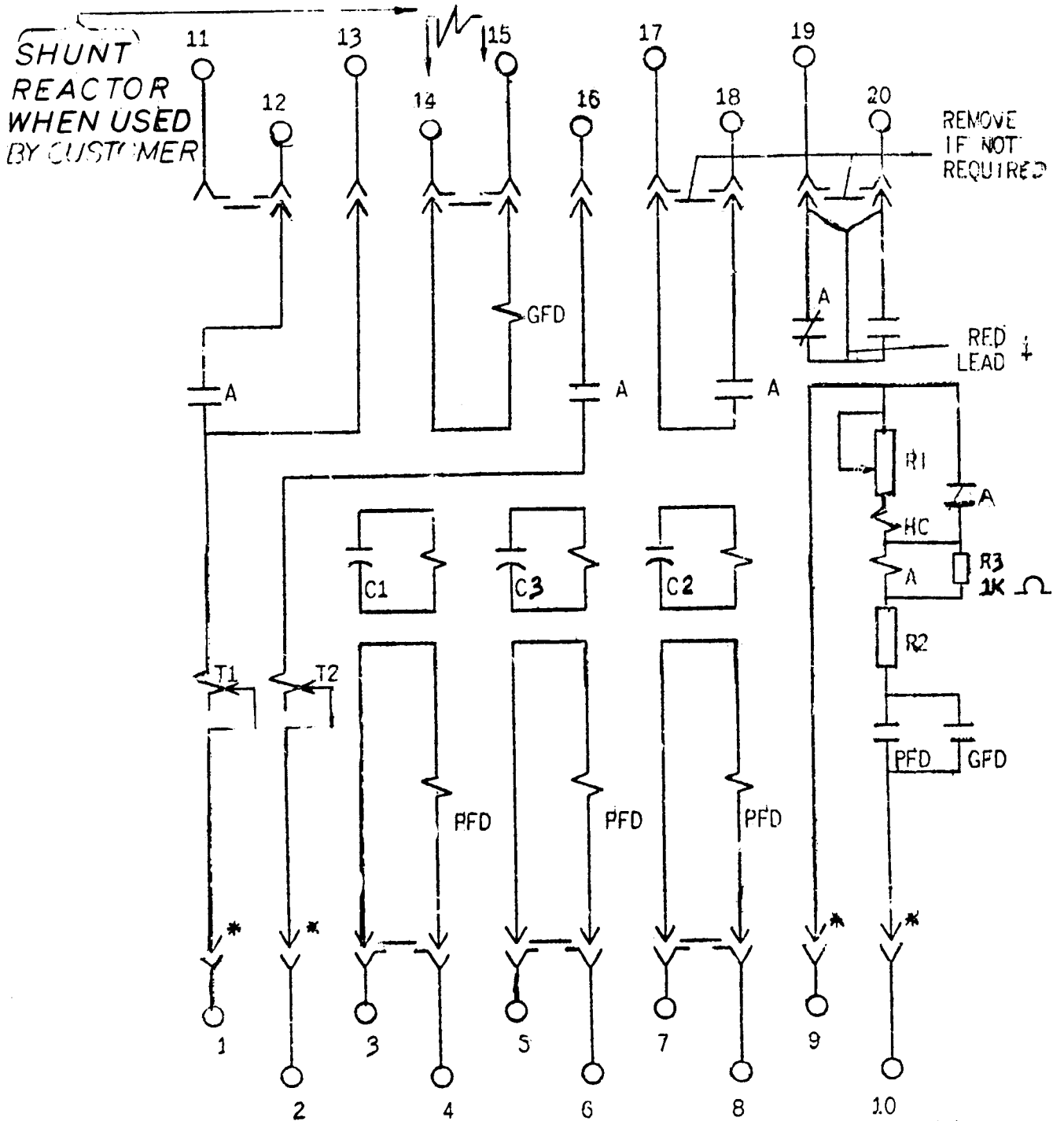

A = TELEPHONE RELAY
 GFD = HINGED ARM. UNIT
 PFD = CUP UNIT

‡ CONNECT TO OBTAIN EITHER NORMALLY OPEN
 OR NORMALLY CLOSED CONTACT.
 HC = HOLDING COIL

* = SHORT FINGER

VOLTS	R1 OHMS	R2 OHMS
250	2000	600
125	1000	300
48	300	50

Fig. 9 (0178A9066-4) Internal Connection Diagram of CHC11A Relay (Front View)

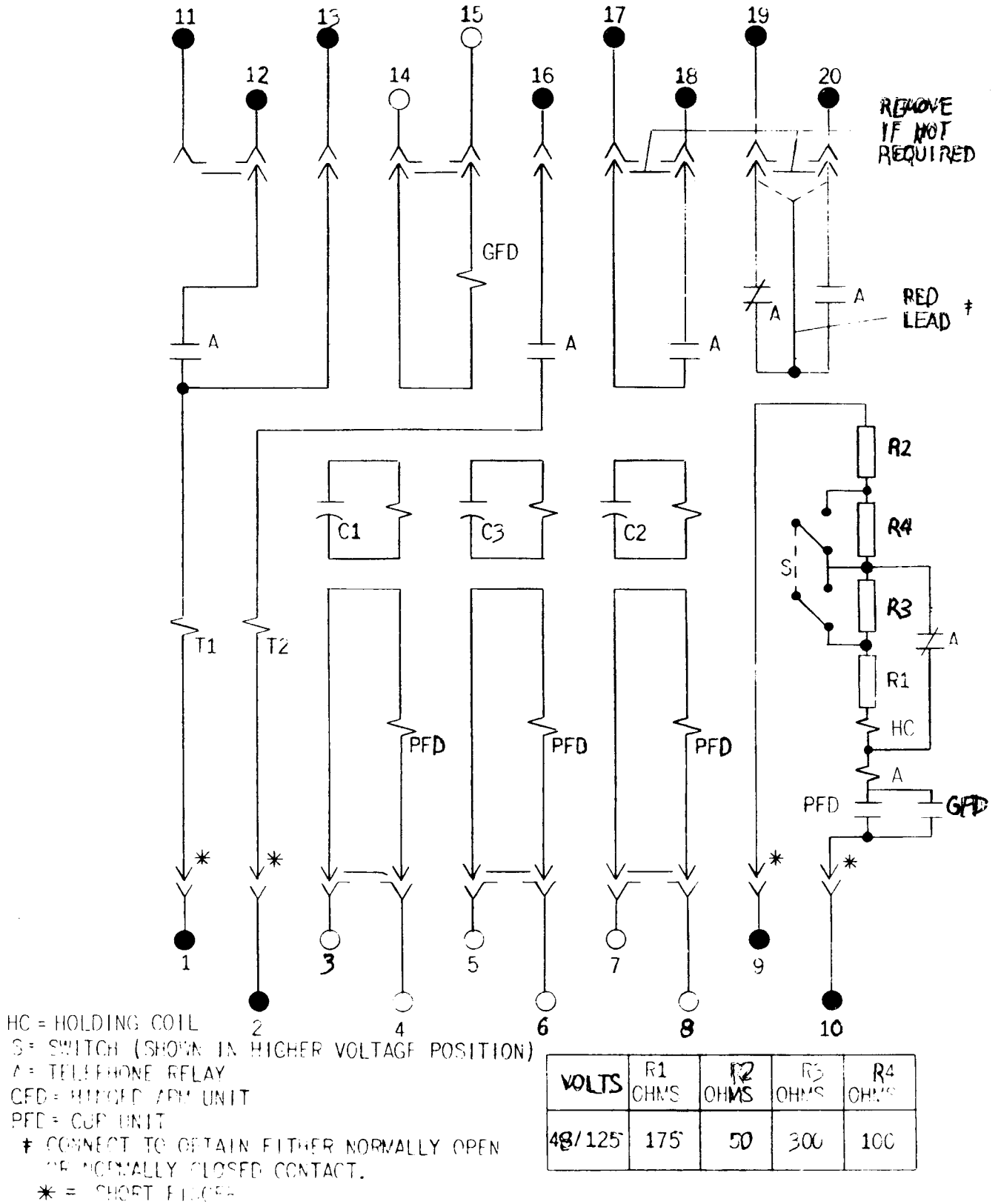
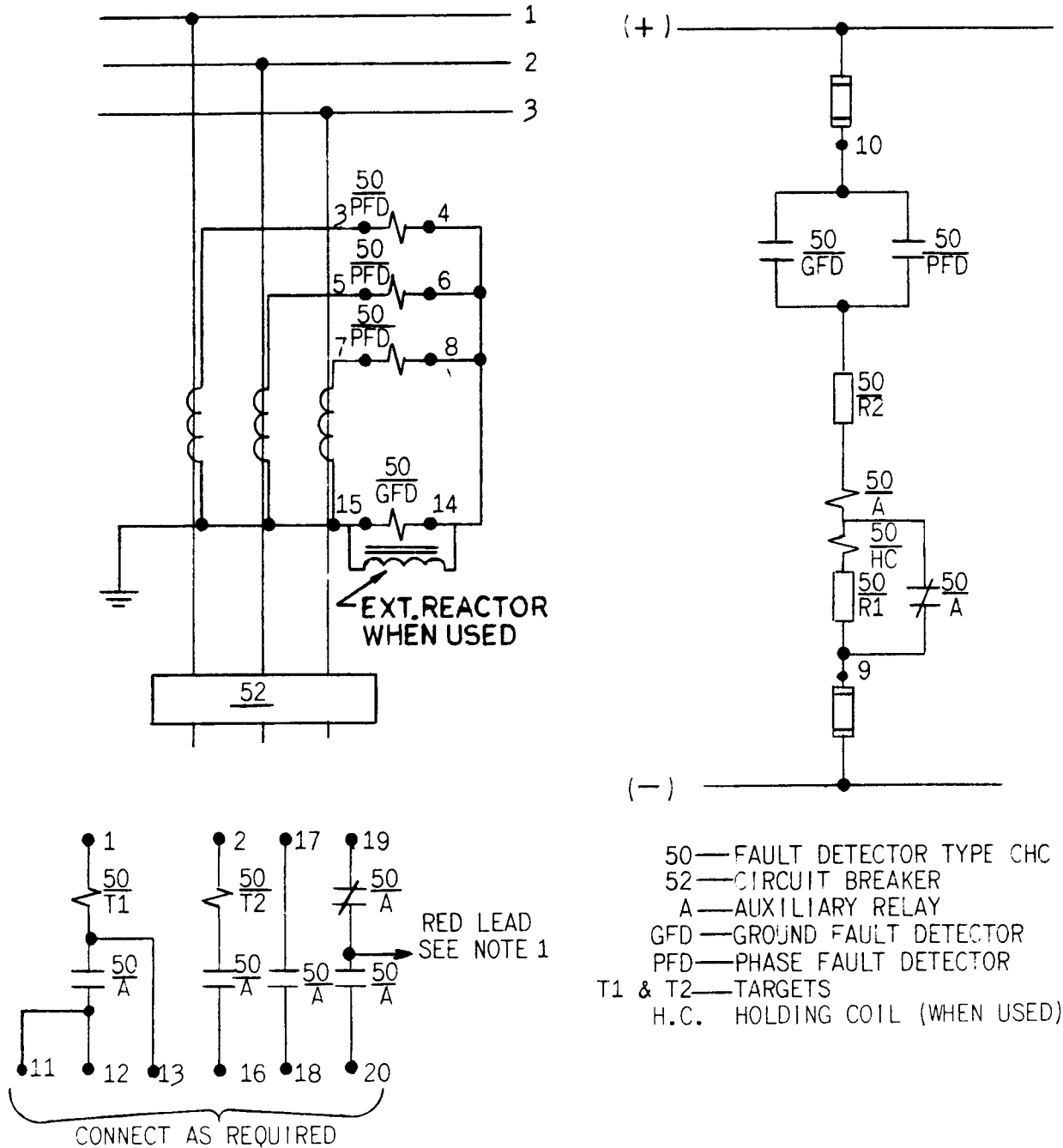
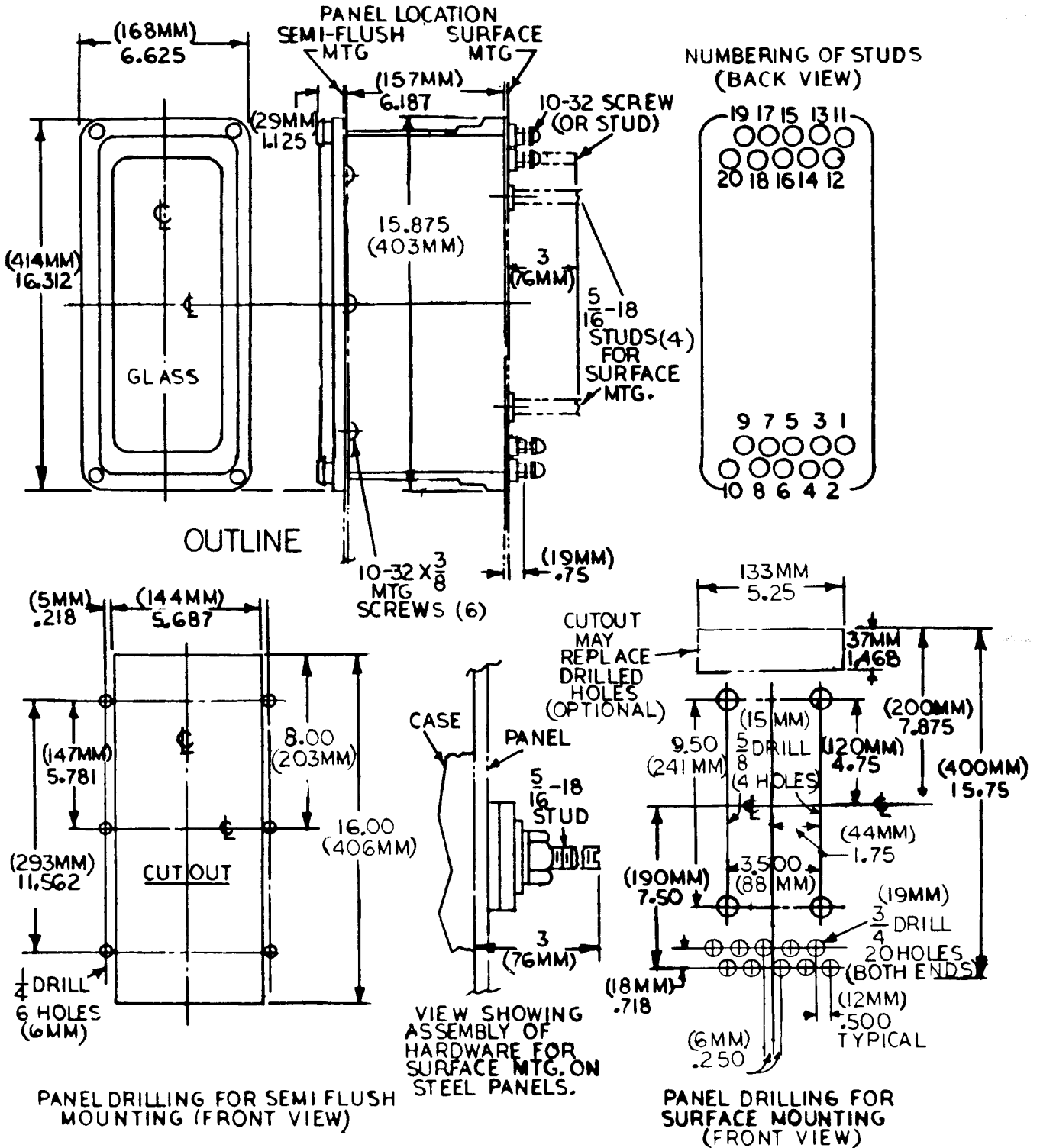

Fig. 10 (0178A9067-0) Internal Connection Diagram of CHC11B Relay (Front View)



NOTE 1 - RED LEAD AVAILABLE. WHEN CONNECTED STUD 19, CONTACT BETWEEN STUDS 19 & 20 IS NORMALLY OPEN. WHEN CONNECTED TO STUD 20, CONTACT BETWEEN STUDS 19 & 20 IS NORMALLY CLOSED.

*Fig. 11 (0127A9420-2) Typical External Wiring Diagram of CHC11A Relay



*Fig. 12 (6209274-4) Outline and Panel Drilling Diagram for CHC11A Relay



**GENERAL ELECTRIC COMPANY
POWER SYSTEMS MANAGEMENT BUSINESS DEPT.
MALVERN, PA 19355**

GENERAL  ELECTRIC



GEK-1253F

INSTRUCTIONS

FAULT DETECTOR RELAY
TYPES CHC11A21 AND UP, CHC11B11 AND UP

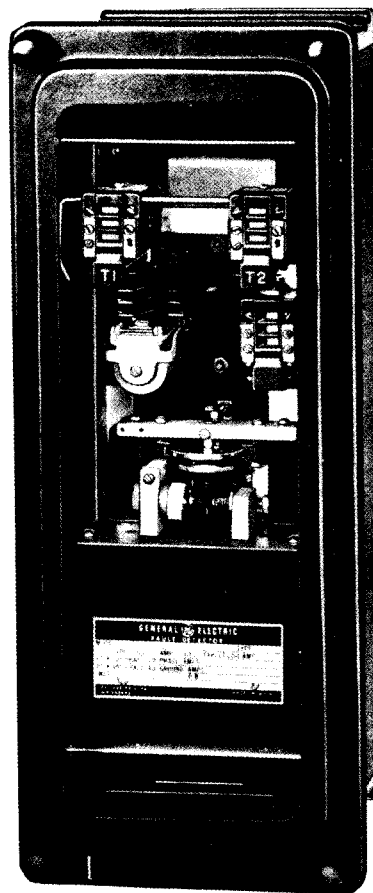

GENERAL ELECTRIC

GEK-1253E

required to re-open a picked-up (closed) normally-open contact of the auxiliary telephone unit when the current is suddenly reduced to zero (0).

RATINGS

The continuously adjustable pickup ranges, the continuous ratings, and the one-second thermal ratings for the overcurrent units are listed in Table II.

TABLE II

UNIT	PICKUP RANGE	CONTINUOUS RATING AMPERES	ONE-SECOND RATING AMPS
PFD	1 - 4	4	150
	2 - 8	8	290
	4 - 16	16	290
	20 - 80	20	325
GFD	0.5 - 2	0.65	18
	1 - 4	1.5	36
	2 - 8	3	72
	4 - 16	6	140
	10 - 40	10	290
	20 - 80	20	400

The auxiliary telephone relay is continuously rated at the nameplate DC voltage. The contact-interrupting capabilities are shown in Table III.

TABLE III
Telephone Relay Contact
Interrupting Capability

VOLTS	AMPS INDUCTIVE†
48DC	1.0
125DC	0.50
250DC	0.25

† Inductance of average trip coil.
The non-inductive ratings are
approximately 2.5 times the
ratings shown

The contacts of the cup unit and the hinged-armature unit are capable of interrupting the auxiliary telephone-unit current.

The current-closing rating of the contacts is 30 amperes for voltages not exceeding 250 volts. The current-carrying ratings are affected by the selection of the tap on the target and seal-in coil, as indicated in the following table:

GEK-1253E

TABLE IV

		DUAL RATED			
		0.2/2.0		0.6/2.0	
		0.2	2.0	0.6	2.0
Carry 30 amps for	(sec)	0.05	2.2	0.5	3.5
Carry 10 amps for	(sec)	0.45	20	5.0	30
Carry continuously	(amp)	0.37	2.3	1.2	2.6
Minimum operating	(amp)	0.2	2.0	0.6	2.0
Minimum dropout	(amp)	0.05	0.5	0.15	0.5
DC resistance	(ohms)	8.3	0.24	0.78	0.18
60 hertz impedance	(ohms)	50	0.65	6.2	0.65
50 hertz impedance	(ohms)	42	0.54	5.1	0.54

If the tripping current exceeds 30 amperes, an auxiliary relay should be used, the connections being such that the tripping current does not pass through the contacts of the target and seal-in coils of the protective relay.

BURDENS

The 60 cycle burden-per-phase of the cup (PFD) unit, with 5.0 amperes flowing in each phase, is listed in Table V.

TABLE V
Burden of PFD Unit

RANGE	VOLT-AMPS AT 5 AMPS	IMPEDANCE	POWER FACTOR LAG
1-4	20	0.8	0.5
2-8	5	0.2	0.5
4-16	1.25	0.05	0.5
20-80	0.05	0.002	0.5

Table VI lists the 60 cycle burdens of the hinged-armature (GFD) unit. These burdens were determined with the unit set at its minimum pickup value.

TABLE VI
Burdens of GFD Unit

RANGE	AT MIN. P.U. CURRENT			AT 5 AMPERES		
	Z	PF	VA	Z	PF	VA
0.5-2	11.8	0.77	2.95	7.6	0.79	19.0
1 - 4	2.95	0.77	2.95	1.9	0.79	47.5
2 - 8	0.74	0.77	2.95	0.5	0.79	11.9
4 -16	0.20	0.77	3.20	0.20	0.79	5.0
10 -40	0.032	0.77	3.20	0.033	0.79	0.83
20 -80	0.008	0.77	3.20	0.008	0.79	0.21

LIST OF FIGURES

- Figure 1 (8035502) Type-CHC Relay Removed from Drawout Case (Front View)
- Figure 2 (0127A7901-2) Time-Current Capability Characteristic of GFD Unit
- * Figure 3 (0127A9438 Sh.4[1]) Maximum Pickup-Time Curves for Cup (PFD) Unit Plus Telephone Unit (A) of CHC11A Relay
- Figure 4 (0127A9438 Sh.3) Maximum Dropout-Time Curve for Cup (PFD) Unit Plus Telephone Unit (A) of CHC11A Relay
- Figure 5 (0127A9438 Sh.1) Maximum Pickup-Time Curve for Hinged-Armature (GFD) Unit Plus Telephone Unit (A) of CHC11A Relay
- * Figure 6 (0127A9438 Sh.2[1]) Maximum Dropout-Time Curve for Hinged-Armature (GFD) Unit Plus Telephone Unit of CHC11A Relay
- Figure 7 (8025039) Cross Section of Drawout Case Showing Position of Auxiliary Brush and Shorting Bar
- * Figure 8 (0127A9448-1) Test Connections for Setting Pickup of PFD and GFD Units
- * Figure 9 (0178A9066-5) Internal-Connection Diagram of CHC11A Relay (Front View)
- Figure 10 (0178A9067) Internal-Connection Diagram of CHC11B Relay (Front View)
- Figure 11 (0127A9420-2) Typical External-Wiring Diagram of CHC11A Relay
- Figure 12 (6209274-4) Outline and Panel-Drilling Diagram for CHC11A Relay

* Revised since last issue

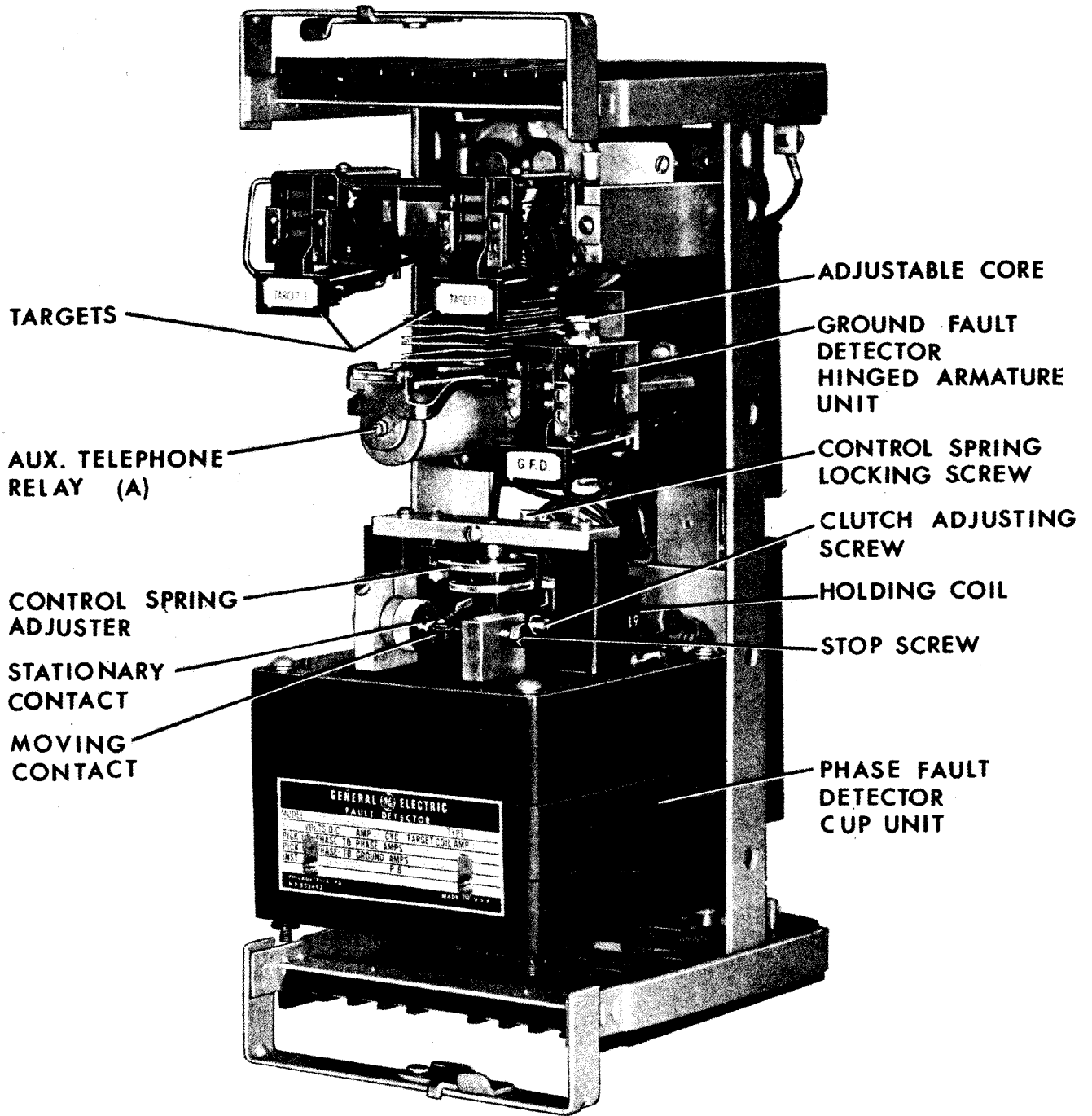

Figure 1 (8035502) Type-CHC Relay Removed from Drawout Case (Front View)

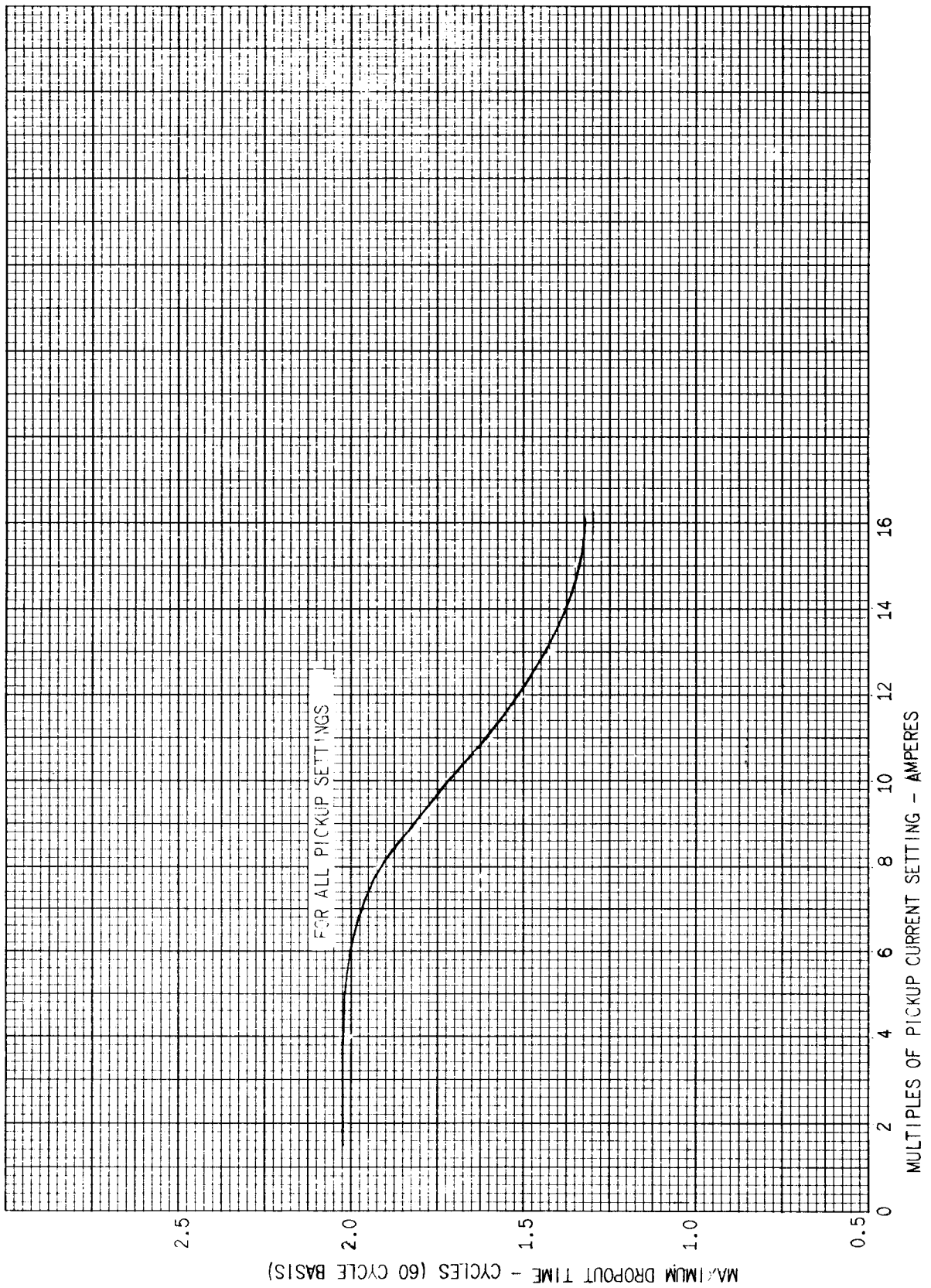

Figure 4 (0127A9438 Sh.3) Maximum Dropout-Time Curve for Cup (PFD) Unit Plus Telephone Unit (A) of CHC11A Relay

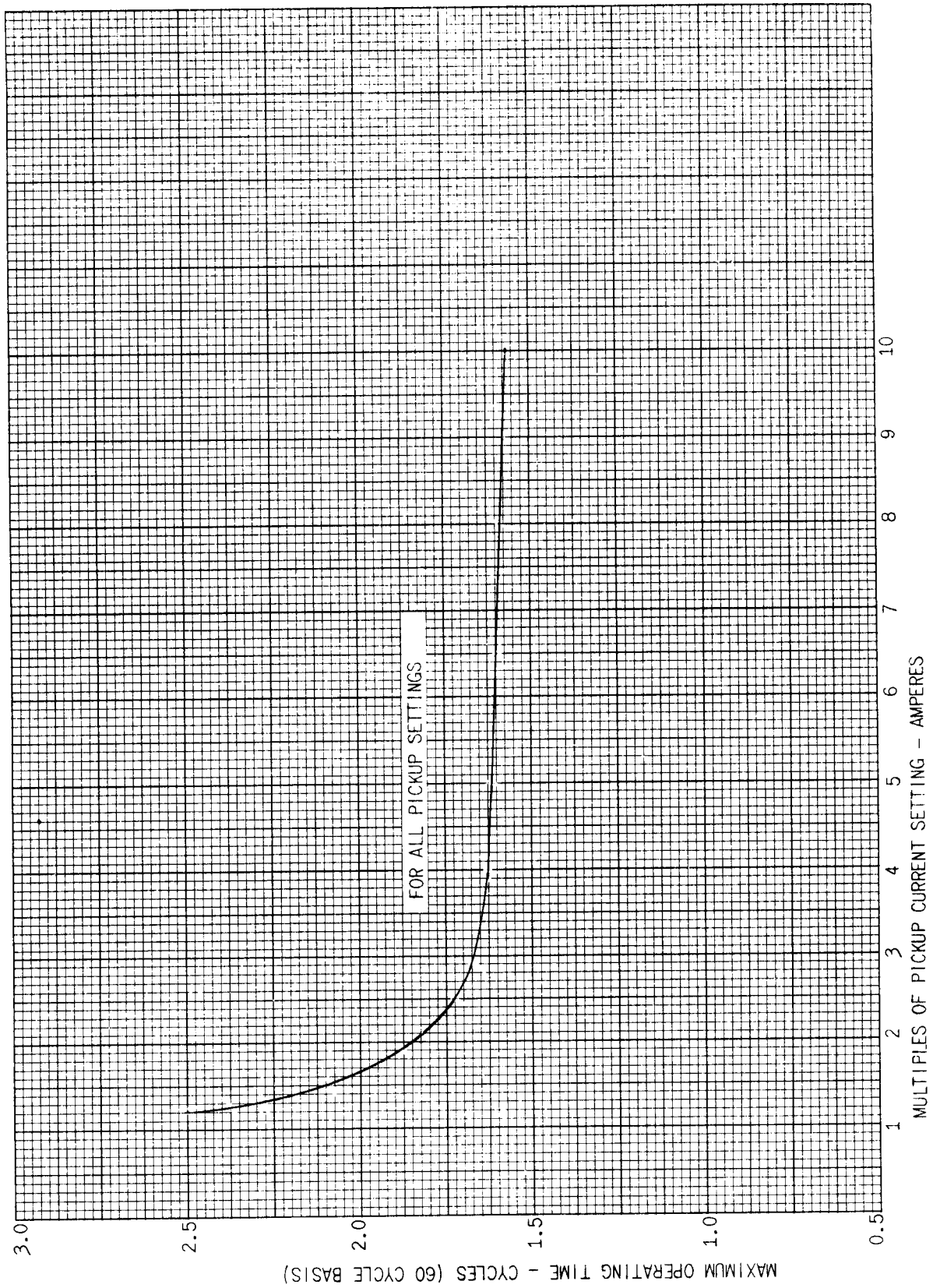
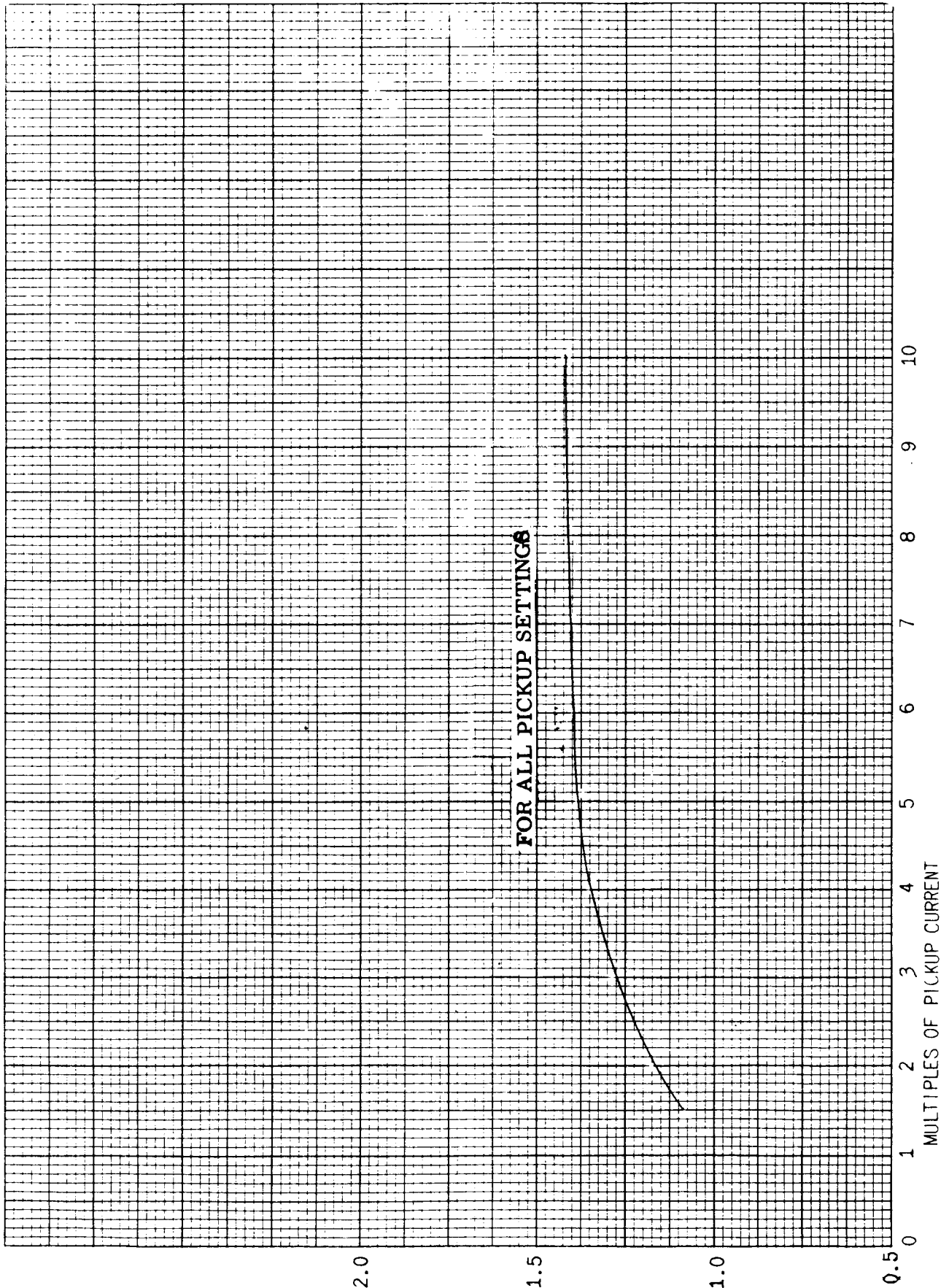

Figure 5 (0127A9438 Sh.1) Maximum Pickup-Time Curve for Hinged-Armature (GFD) Unit Plus Telephone Unit (A) of CHC11A Relay

MAXIMUM TOTAL DROPOUT TIME OF GROUND FAULT DETECTOR (HINGED ARM. UNIT) PLUS AUXILIARY TELEPHONE UNIT (A) WHEN OPERATING CURRENT IS SUDDENLY REDUCED FROM ITS VALUE TO ZERO.



MAXIMUM DROPOUT TIME - CYCLES (60 CYCLE BASIS)

- * Figure 6(0127A9438 Sh.2 [1])Maximum Dropout-Time Curve for Hinged-Armature (GFD) Unit Plus Telephone Unit of CHC11A Relay
- * Revised since last issue

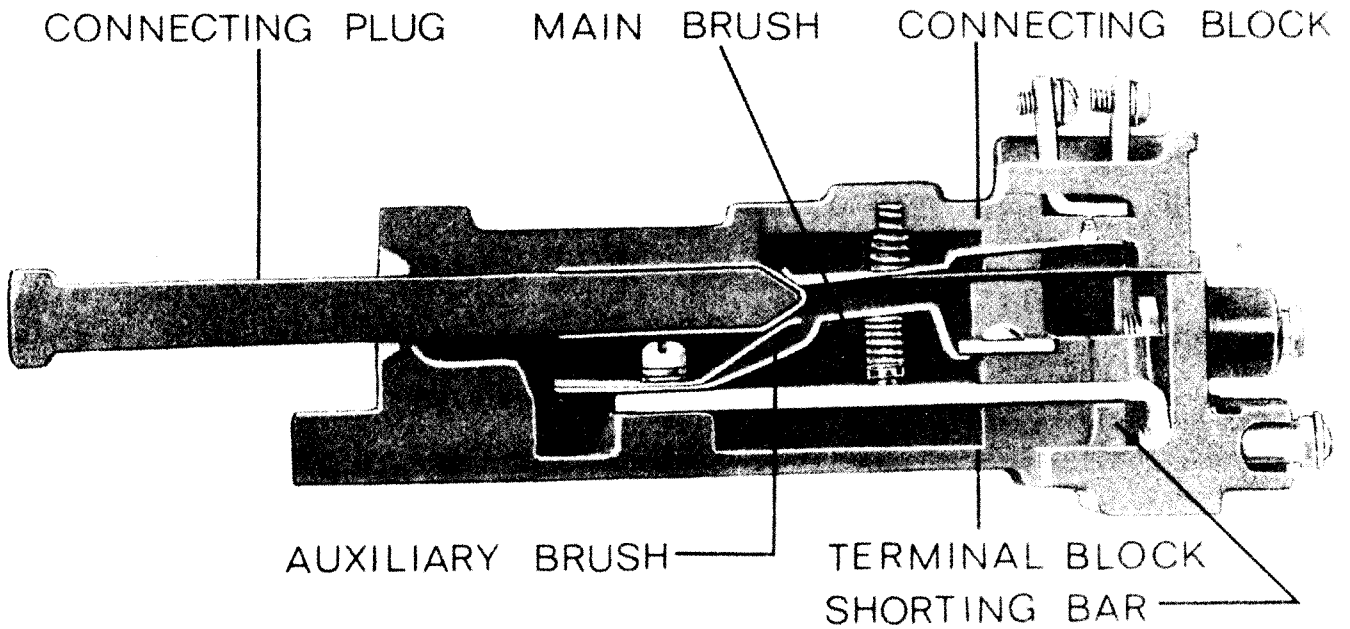

NOTE: AFTER ENGAGING AUXILIARY BRUSH CONNECTING PLUG TRAVELS $\frac{1}{4}$ INCH BEFORE ENGAGING THE MAIN BRUSH ON THE TERMINAL BLOCK

Figure 7 (8025039) Cross Section of Drawout Case Showing Position of Auxiliary Brush and Shorting Bar

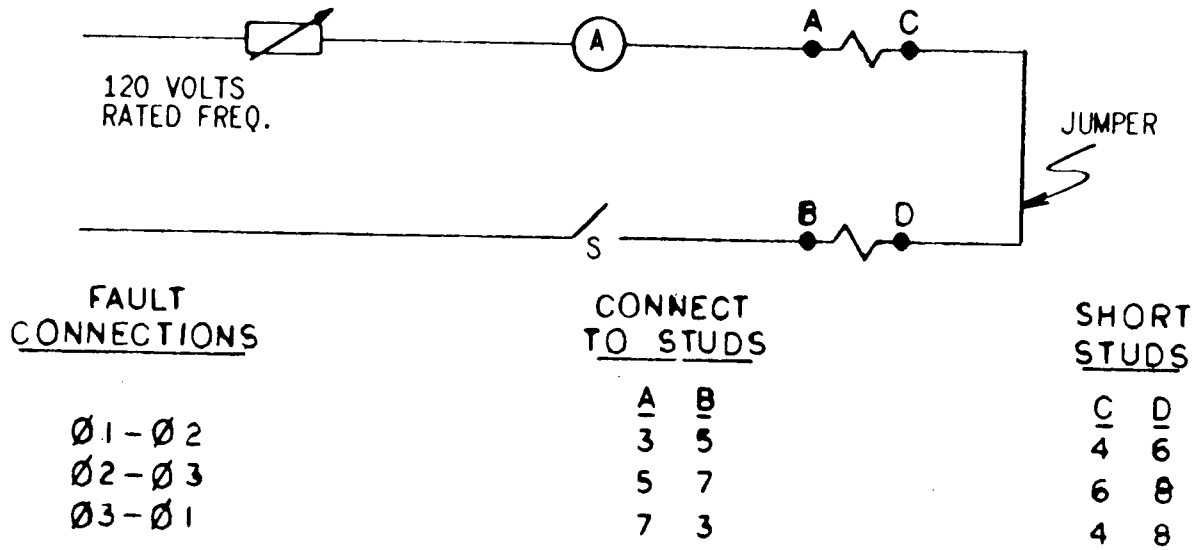

A. CONNECTIONS FOR SETTING PICKUP OF CUP (PFD) UNIT

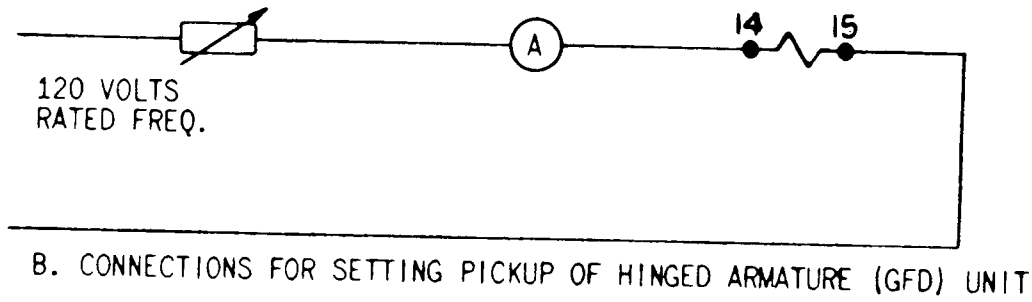

* Figure 8 (0127A9448-1) Test Connections for Setting Pickup of PFD and GFD Units

* Revised since last issue

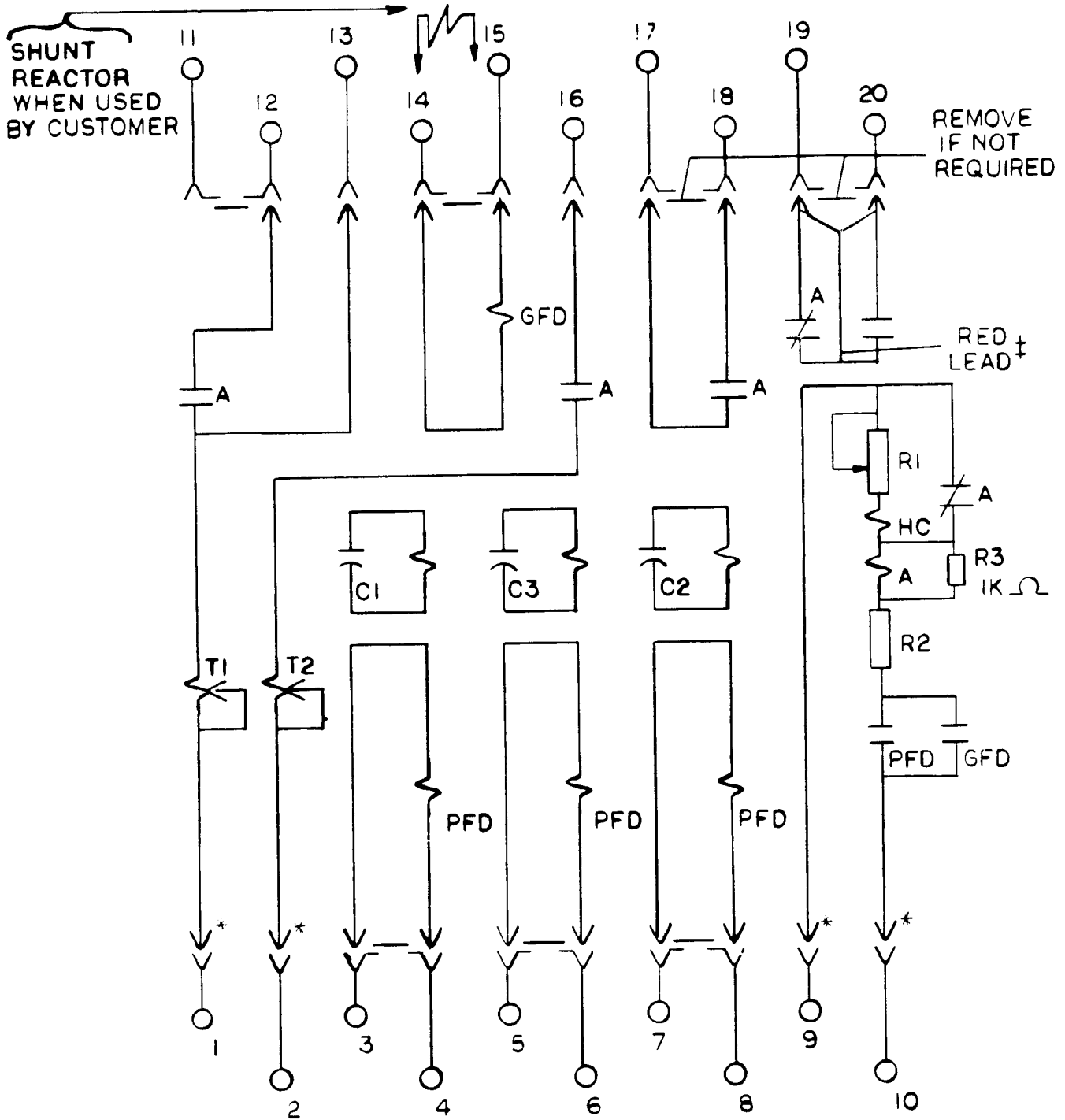

A = TELEPHONE RELAY
 GFD = HINGED ARM UNIT
 PFD = CUP UNIT

* SHORT FINGER

‡ CONNECT TO OBTAIN EITHER NORMALLY OPEN OR NORMALLY CLOSED CONTACT

HC = HOLDING COIL.

VOLTS	R1 OHMS	R2 OHMS
250	2000	600
125	1000	300
48	300	50

* Figure 9 (0178A9066-5) Internal-Connection Diagram of CHC11A Relay (Front View)

* Revised since last issue

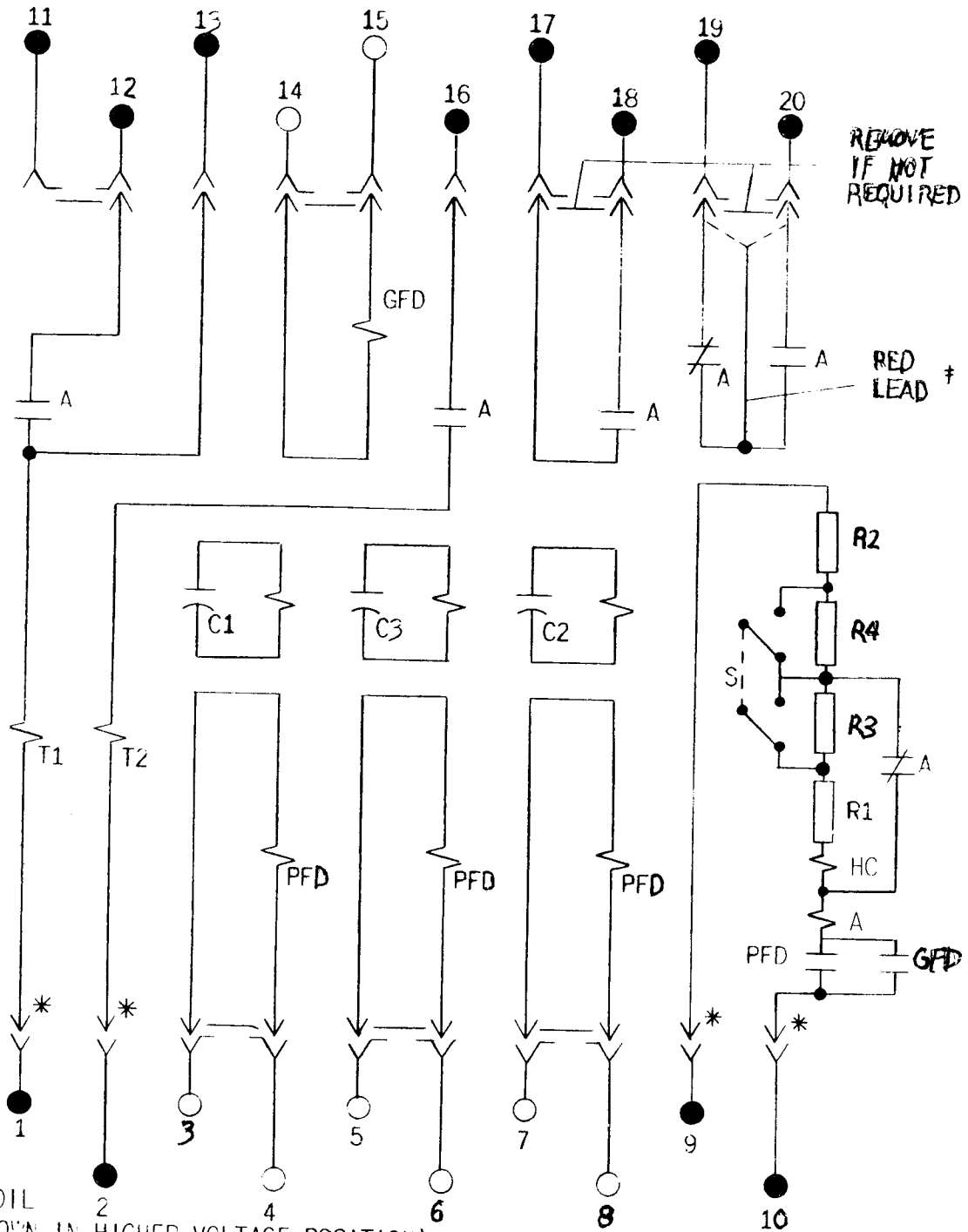

HC = HOLDING COIL
 S = SWITCH (SHOWN IN HIGHER VOLTAGE POSITION)
 A = TELEPHONE RELAY
 GFD = HINGED ARM UNIT
 PFD = CUP UNIT
 † CONNECT TO OBTAIN EITHER NORMALLY OPEN
 OR NORMALLY CLOSED CONTACT.
 * = SHORT FINGER

VOLTS	R1 OHMS	R2 OHMS	R3 OHMS	R4 OHMS
48/125	175	50	300	100

Figure 10 (0178A9067) Internal-Connection Diagram of CHC11B Relay (Front View)

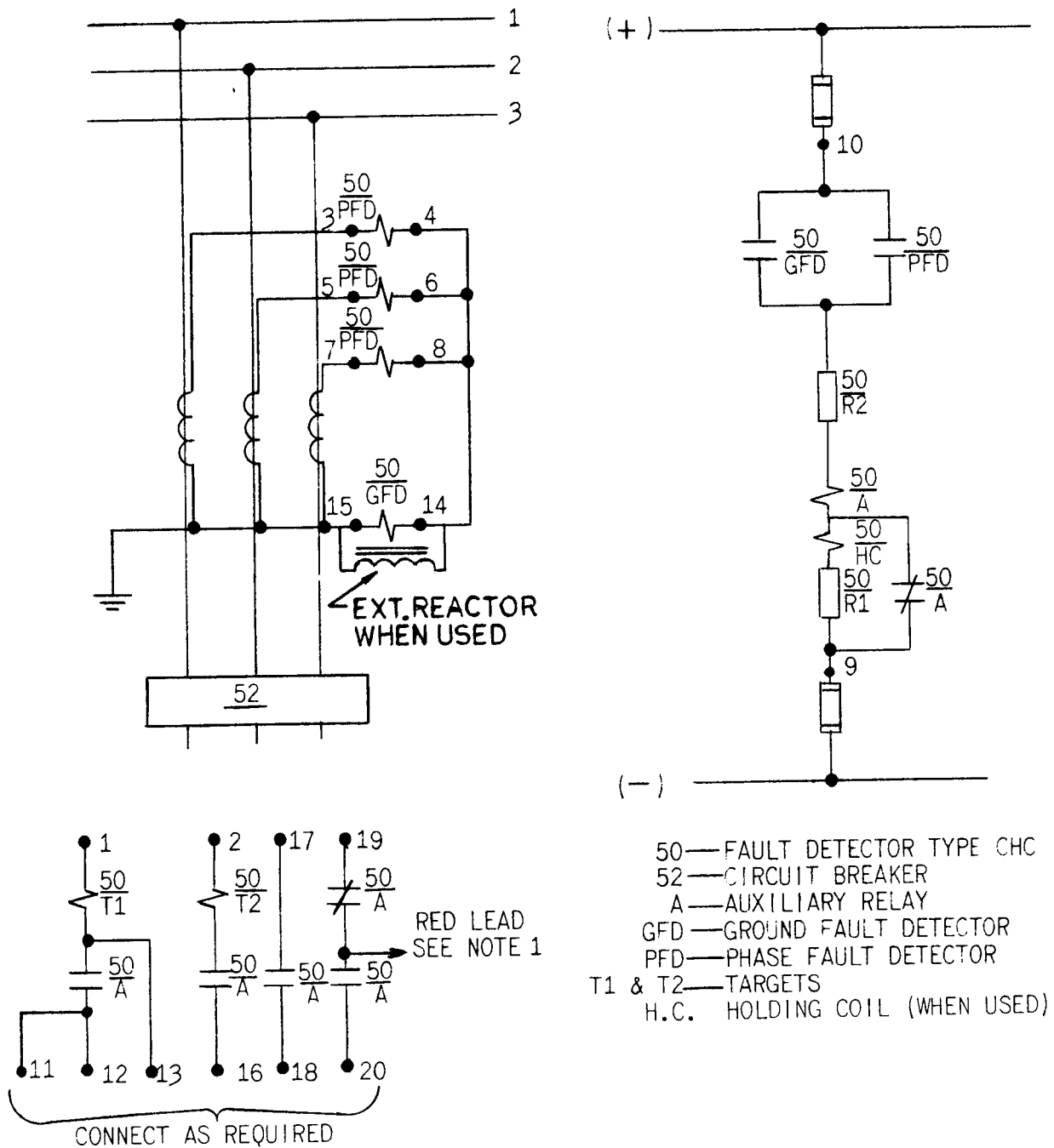

NOTE 1 - RED LEAD AVAILABLE. WHEN CONNECTED STUD 19, CONTACT BETWEEN STUDS 19 & 20 IS NORMALLY OPEN. WHEN CONNECTED TO STUD 20, CONTACT BETWEEN STUDS 19 & 20 IS NORMALLY CLOSED.

Figure 11 (0127A9420-2) Typical External-wiring Diagram of CHC11A Relay

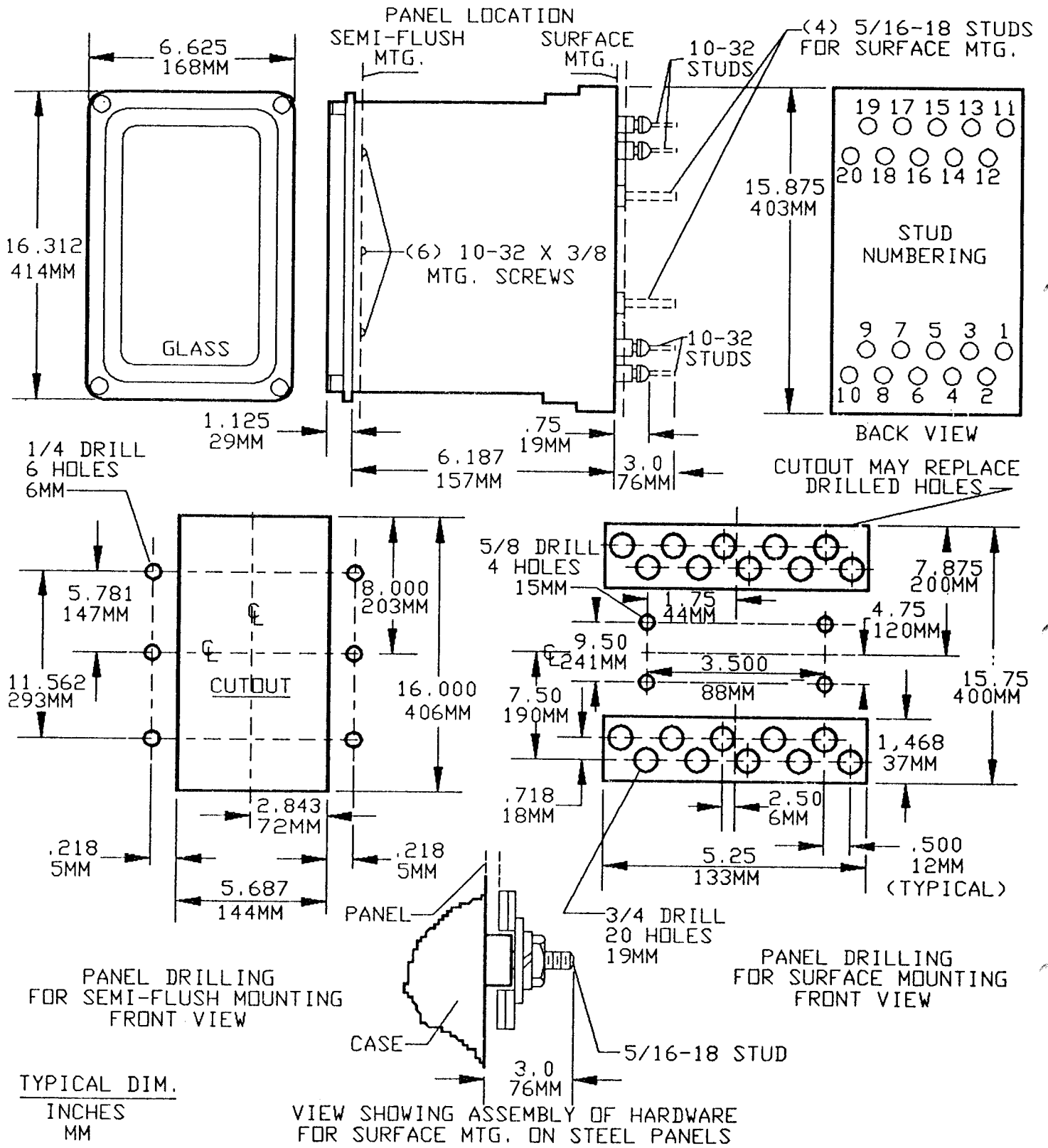

* Figure 12 (6209274-4) Outline and Panel-Drilling Diagram for CHC11A Relay

* Revised since last issue

***Meter and Control
Business Department***

(3/91) (1500)

General Electric Company
205 Great Valley Parkway
Malvern, Pennsylvania 19355-0715