



INSTRUCTIONS

GEK-27919D
Supersedes GEK-27919C

SYNCHRONIZING RELAY

TYPES

GES21A

GES21B

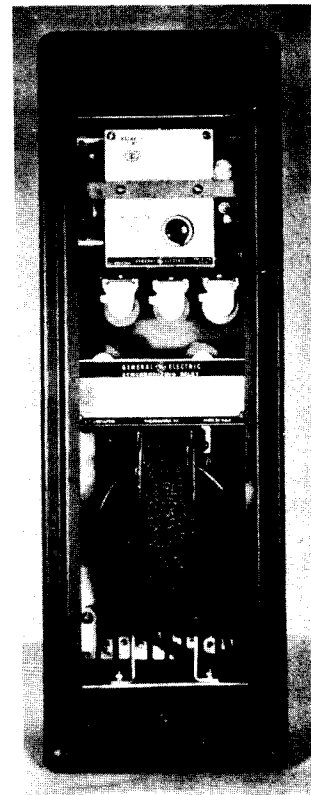

GENERAL  ELECTRIC

CONTENTS

	<u>PAGE</u>
DESCRIPTION.....	3
APPLICATION.....	4
RATINGS.....	6
AC BURDEN.....	6
DC BURDEN.....	6
CHARACTERISTICS.....	6
UNBALANCED VOLTAGES.....	7
PRINCIPLES OF OPERATION.....	7
DESCRIPTION OF OPERATION.....	7
PHASING VOLTAGE.....	7
ADVANCE VOLTAGE.....	8
COMPENSATING VOLTAGE.....	8
LEVEL DETECTOR.....	9
LOW PASS FILTER.....	9
IMPEDANCE CONVERTER.....	9
REFERENCE VOLTAGE.....	9
VOLTAGE COMPARATOR.....	9
RELAY DRIVER.....	9
POWER SUPPLY.....	9
CUTOFF ANGLE (C) RELAY.....	10
SEQUENCE OF OPERATION AT HIGH SLIP FREQUENCY...	10
SEQUENCE OF OPERATION AT LOW SLIP FREQUENCY....	10
CONSTRUCTION.....	11
RECEIVING, HANDLING AND STORAGE.....	11
ACCEPTANCE TESTS.....	11
VISUAL INSPECTION.....	11
MECHANICAL INSPECTION.....	12
ELECTRICAL TESTS.....	12
INSTALLATION PROCEDURE.....	12
LOCATION.....	12
MOUNTING.....	12
CONNECTIONS.....	12
ADJUSTMENTS.....	12
ADVANCE TIME.....	12
HIGH DIFFERENCE FREQUENCY CUTOFF.....	13
PERIODIC CHECKS AND ROUTINE MAINTENANCE.....	14
SERVICING.....	15
LEVEL DETECTOR CARD.....	15
SETTING AN ADVANCE TIME.....	16
SETTING CUTOFF.....	17
TELEPHONE RELAYS.....	17
RENEWAL PARTS.....	18

SYNCHRONIZING RELAY

TYPES GES21A and GES21B

DESCRIPTION

The type GES21A and GES21B relays are automatic synchronizing relays which automatically synchronize any kind of large or small synchronous generator on to an operating system. These relays measure the speed of the incoming generator relative to the system and the phase angle between the generator and the system, and then produce a closing signal to the associated circuit breaker at the proper instant to cause the breaker poles to close at the instant when the generator and system voltages are essentially in phase. The relays require that a frequency difference exist in order to operate. They will not give a closing signal to the breaker if the incoming machine and the system are at exactly the same frequency, regardless of whether or not they are in phase.

The GES21A relay is factory-calibrated for a single breaker closing, which may be any value between .05 second and 1.0 second. The GES21B relay is factory-calibrated for two different closing times, and has provision for switching from one closing time to the other with an external control switch or relay contact. The limitation on the two closing times is that either (a) they must both be less than 300 milliseconds, or (b) the ratio of the two times must be three-to-one or less. In addition, both times must be within the range of .05 to 1.0 second.

The GES21A relay may be used with one specific generator, or it may be used to synchronize a number of different machines, provided that the associated circuit breakers all have the same closing times. Likewise, the GES21B may be used with two specific generators, or with two groups of generators.

The input signal to the GES21A or GES21B relay is a single phase voltage from the incoming machine and a corresponding single phase voltage from the system. The relays may be used in conjunction with additional equipment such as speed-matching and voltage-matching or voltage-checking relays. For information on these additional functions, please contact your local General Electric Company District Sales Office.

The GES21A and GES21B relays are mounted in an L2-D case, whose outline and drilling dimensions are shown in Figure 9. Figure 13 is the internal connection diagram for the GES21A relay and Figure 17 is the internal connection diagram for the GES21B relay.

These instructions do not purport to cover all details or variations in equipment nor to provide for every possible contingency to be met in connection with installation, operation or maintenance. Should further information be desired or should particular problems arise which are not covered sufficiently for the purchaser's purposes, the matter should be referred to the General Electric Company.

To the extent required the products described herein meet applicable ANSI, IEEE and NEMA standards; but no such assurance is given with respect to local codes and ordinances because they vary greatly.

APPLICATION

The GES21A and GES21B relays are easy to apply as far as settings are concerned. The only setting which should be made by the user is the cutoff slip frequency, or the maximum slip frequency for which the relay will permit breaker closing. This will be discussed in more detail below.

For a given breaker closing speed, the relay will determine, as a function of slip, the angle in advance of the in-phase condition at which the closing impulse must be given to the breaker. This angle, referred to as the advance angle, can be calculated as follows:

$$A = 3600 \times S \times t$$

where: A = Advance angle in degrees
S = Slip frequency in hertz
t = Breaker closing time in seconds

Thus, for a breaker closing time of 0.2 second, and with a slip frequency of 0.15 Hz, the above equation indicates that the closing impulse to the breaker should be given 10.8° in advance of the in-phase condition. With the machine continuing at the same slip speed, it will take exactly 0.2 second (the closing time of the breaker) to travel the 10.8° to the in-phase condition. For the same breaker, but with a slip of 0.30 Hz, the closing impulse will be given at an advance angle of 21.6°.

The closing time (or closing times for the GES21B relay) of the breaker (or breakers) with which the relay will be used must be programmed into the relay. This is usually done in the factory before shipment, and this information should accompany the order for the relay. Thus, the adjustment of the relay to accommodate a given breaker-closing time is not intended to be made in the field. However, it can be made in the field if necessary and if suitable test equipment is available; the information regarding the necessary adjustments is given in the SERVICING section.

The limiting slip frequency and advance angle for which the relay will operate is controlled by the dropout setting of the C (Cutoff) relay. This "slip cutoff setting" is factory calibrated, as described below, to be not more than 0.33 Hz slip frequency, nor more than 45° advance angle. A dial on the front of the relay permits the user to reduce the cutoff setting below the factory setting.

In the GES21A relay, the slip cutoff setting made in the factory is determined by the single breaker time setting provided when ordering the relay. If the breaker time setting is less than 0.38 second, the relay is set for a maximum cutoff frequency of 0.33 Hz, and the actual advance angle will be less than 45°. If the breaker time is greater than 0.38 second, the factory cutoff setting is made on the basis of the 45° advance angle limit, and the actual cutoff slip frequency will be less than 0.33 Hz. If the breaker time is 0.38 second the cutoff slip frequency is 0.33 Hz and the cutoff advance angle is 45°.

In the GES21B relay, the same physical cutoff setting adjustment applies for both advance time settings. The factory cutoff adjustment is made such that the actual cutoff frequency (or cutoff angle) will be equal to or less than 0.33 Hz slip frequency or 45° advance angle for both advance time settings. For example, if both

time settings are less than 0.38 second, the cutoff frequency will be 0.33 Hz for the shorter advance time and something less than this for the longer advance time.

In both the GES21A and the GES21B, the slip cutoff frequency dial is continuously adjustable between 40 and 100% of the factory setting, and also has calibration markings at 60% and 80% of the factory setting. Settings less than 40% or more than 100% should not be used.

The choice of the slip cutoff setting to be used depends on several factors, such as the size of the machine and the precision with which the frequency of the generator can be matched to the system frequency.

It should be noted that the accuracy of the actual synchronizing when the breaker poles close depends on the generator speed remaining constant after the breaker closing signal has been given, and that it is the same speed which was present when the advance angle was being determined. If there is a change in speed while the breaker is closing there will be an error in the final angle, and this error will be greater at higher slip frequencies than at lower slip frequencies. For this reason, therefore, there is an advantage to using a lower slip cutoff setting.

In general, higher slip cutoff settings will permit faster automatic synchronizing. This is so because the process of manually or automatically matching the speed of the generator to the system will tend to take less time if the speed match does not have to be made very precisely. Conversely, lower slip cutoff settings will tend to require longer synchronizing times. Where speed of synchronizing is not a critical factor, low slip cutoff settings are suggested. Breakers with fast closing times in combination with low slip cutoff settings will usually provide the best overall performance.

The accuracy of the relay is somewhat dependent on the applied voltages. With rated voltages applied, the relay will provide a closing signal to the breaker that will result in the main poles closing within $\pm 5^\circ$ of the in-phase position. For voltages other than rated, the typical error is given in the curves of Figure 6a through 6d.

The relay is designed with solid state components; therefore it is not necessary to allow for warm-up time when applying the relay. For proper security in applying the relay, it is necessary **first** to apply both AC potentials; **next apply** the DC potential **and simultaneously** connect the F auxiliary relay contact into the breaker closing circuit. The reverse order should be followed in de-energizing the relay. This is best done by the proper design of the sequence of operations of the "43" selector device. This is illustrated in the external connection diagram of Figure 2. When one relay is used to synchronize a number of machines in the same station, it is necessary to allow some time for the relay to reset before applying it to the next machine to be synchronized. If a selector switch as described above is used with each machine, a common handle is provided which must be moved from switch to switch before synchronizing can be performed, thus introducing the necessary time delay. On the other hand, if the relay is used in an automatic synchronizing scheme whereby the relay is automatically switched from machine to machine, it will be necessary to allow some time delay to permit the relay to reset before applying it to the next machine. The time delay should be introduced by adding a set of timer contacts in series with the DC supply to the relay. The time delay should start simultaneously

with the application of the last potential to the relay. A minimum time delay of one (1) second is suggested.

A contact of the B (Level Detector) relay (which operates at the instant that the closing signal should be given) is connected across studs 2 and 3 of the relay so that it may be used to control an indicating lamp if the GES is used as a check when synchronizing manually.

The GES21 relay may be used in conjunction with additional equipment such as speed matching and voltage matching or voltage checking. For information on these additional functions, please contact your nearest General Electric Company District Sales Office.

RATINGS

The contacts of the F (Final Auxiliary) relay, which come out to studs 1 and 2, have the following current ratings:

Make and Carry 30 Amperes for 1 Second

<u>INTERRUPTING ABILITY</u>	
<u>VOLTS</u>	<u>AMPS INDUCTIVE</u>
48 DC	1.0
125 DC	0.5
250 DC	0.25
120 AC	0.75
240 AC	0.5

AC BURDEN

The burden on each AC source is 7.5 volt-amperes or less for the 60 Hz model relays. The burden is greatest at 180° phase displacement, and decreases slightly as the phase angle decreases to 0. Lower frequency models have slightly higher burdens.

DC BURDEN

The DC burden is less than 0.2 ampere for the 125 and 250 volt rated relays.

CHARACTERISTICS

The relay will not operate if the slip frequency is greater than 0.33 Hz or if the angular difference between the two voltages would be greater than 45° at the time that the closing signal would have to be given. The first requirement is the limiting factor for breakers whose closing time is faster than 0.38 second, and the second applies for slower breakers.

The relay will not operate to synchronize two systems if the systems have a fixed angular relationship. The minimum requirement is that the two voltages should be 180° out of phase when the relay is first energized and then should move to the in-phase position. It is preferable that the two systems slip continuously at a slow rate so the relay will have several opportunities to synchronize them.

UNBALANCED VOLTAGES

The relay is adjusted so that it will attempt to synchronize when the two applied voltages are not equal if they are both within the limits of -20% to +10% of rating; however, the angular error will increase with greater voltage difference. If the voltages are equal but different from the rating, the angular error will be less than if the voltages are unequal. Figure 6 shows typical angular errors for various conditions.

PRINCIPLES OF OPERATION

The GES21 relay is designed to give a closing signal to the generator circuit breaker so that the circuit breaker will close its contacts when the generator and the system are in phase. As the generator circuit breaker has a time delay (assumed to be constant) between the receipt of a closing signal and the closing of its contacts, the GES21 must give its closing signal in advance of synchronism by a time equal to the circuit breaker closing time.

This time before synchronism (advance time) can be converted to an angle before synchronism (advance angle) if the slip frequency is known, by the formula:

$$\text{Advance Angle (degrees)} = 360 \times \text{Slip Frequency (Hz)} \times \text{Advance Time (second)}$$

For a given breaker closing time, the advance angle will increase in direct proportion to the slip frequency. The GES21 is adjusted so that it will not give a closing signal when the advance angle would be greater than 45°.

DESCRIPTION OF OPERATION

The voltage applied to the level detector is the sum of three components, as sketched for one slip cycle in Figure 3 and as listed below:

1. "Phasing" voltage - proportional to the phase angle at equal voltages.
2. "Advance" voltage - proportional to the frequency difference within the operating zone.
3. "Compensating" voltage - proportional to the unbalance of the two voltages.

PHASING VOLTAGE

Referring to Figure 2, the phasing voltage is taken from a rectifier, supplied by the X₁ - X₂ secondaries of the two 2:1 insulating transformers. The primaries of these transformers are connected to the two sources to be synchronized, and the secondaries are connected in opposition, so that the resultant is 0 when the voltages are equal and in phase, and a maximum when they are 180° out of phase. For purposes of adjustment, the phasing voltage is taken from a voltage divider network across the phasing rectifier consisting of a fixed resistor, potentiometer R20, and the primary of the advance transformer.

The phasing voltage component of the voltage that controls the level detector is the voltage from pin 3 on the level detector printed circuit board socket to the wiper of

the advance adjusting rheostat R20 (See Figure 2). The phasing voltage component tends to make pin 7 of the level detector negative with respect to pin 3.

As the phase angle increases toward 450, the phasing voltage increase more slowly than the phase angle; the saturation of the compensating rectifier tends to compensate for this condition.

ADVANCE VOLTAGE

The advance voltage is induced in the secondary of the advance transformer by the change in primary current of this transformer as the phase angle changes. The connections are made so that when the phase angle is decreasing the advance voltage tends to make the voltage on pin 7 of the level detector positive with respect to pin 3 (see Figure 3).

COMPENSATING VOLTAGE

When the machine and bus voltages are equal, the resultant voltage applied to the level detector is the sum of the phasing and advance voltages, as shown in Figure 3A, since the compensating voltage is 0. Because the advance voltage is proportional to frequency difference, the resulting voltage reverses polarity at a variable angle, but at a definite time in advance of synchronism.

The compensating voltage compensates for any inequality of the two applied voltages. It is produced as follows:

1. The two source voltages are taken from the X₃-X₄ secondaries of the 2:1 stepdown insulating transformers and rectified by two full wave bridge rectifiers, which produce two DC voltages proportional to the two source voltages.
2. These two rectifiers are joined at their negative terminals and each one is loaded by a resistor (R1 and R2). The purpose of these loading resistors is to allow current to flow into the rectifier bridge with the lower voltage.
3. The difference between the two voltages is fed through a third full wave bridge rectifier to obtain a difference voltage of constant polarity. A filter capacitor across the input reduces the ripple component of the voltage difference.
4. This difference voltage of constant polarity is fed to a potentiometer, R22, labeled compensation adjust, where a portion of it is utilized as the compensating voltage.
5. The compensating voltage (see Figure 3C) is the voltage from the positive terminal of the compensating voltage rectifier to the wiper of the compensating adjust potentiometer. This voltage only appears when the two sources are unbalanced and it is proportional to the amount of unbalance. Its polarity always opposes the phasing voltage and tends to make pin 7 of the level detector positive with respect to pin 3. The potentiometer is adjusted so that, with the two sources in phase (0° difference) but unbalanced in magnitude, the compensating voltage just cancels the phasing voltage.

The resultant voltage, which controls the level detector, is shown in Figure 3B for the condition where the machine and bus voltages are unequal. It is negative at 180° phase displacement, 0 at a definite time (but a variable angle) in advance of synchronism, and positive from that instant until synchronism is reached. It then reverses and remains negative through the remainder of the slip cycle.

LEVEL DETECTOR

The function of the printed circuit card level detector is to pick up the B telephone relay when its input signal is greater than 0. The circuit consists of a low pass filter, an impedance converter, a voltage comparator, a relay driver and a power supply. The function of each section is explained below.

Low Pass Filter

The resultant voltage applied to the input of the level detector contains high frequency components in the 100 Hz range as well as the desired signal, whose frequency is below 1 Hz. The low pass filter removes the high frequency components without shifting the phase of the low frequency signal.

Impedance Converter

The signal supplied to the level detector card comes from a high impedance source (the secondary of the advance transformer). Before further processing, its impedance level is lowered by a field effect transistor used in a unity gain, source follower, impedance converter.

Reference Voltage

The potentiometer on the printed circuit card provides an adjustable reference voltage to be compared against the signal voltage.

Voltage Comparator

An integrated circuit operational amplifier used as an inverting polarity detector with hysteresis looks at the weighted sum of the reference voltage and the output of the impedance converter. When the weighted sum is greater than 0 its output terminal goes negative. The comparator is designed to have a small amount of hysteresis to give snap action and to help prevent chattering.

Relay Driver

The relay driver energizes the coil of the B telephone relay when the output of the voltage comparator goes negative.

Power Supply

The power supply, consisting of two avalanche voltage regulator diodes, supplies the regulated voltages for the several devices on the card and also for the B telephone relay. The voltage regulator diodes isolate the level detector card from changes in the DC control voltage.

CUTOFF ANGLE (C) RELAY

The output of the phasing voltage bridge rectifier is 0 when the two source voltages are equal and in phase, and maximum (about 120 volts) when they are 180° out of phase. This voltage is fed to the C (Cutoff) telephone relay and its series rheostat R23. The C relay drops out to permit synchronizing when the two source voltages are within the allowable phase angle. If the two source voltages are unequal, then the range of phase angle over which the C relay will permit synchronizing becomes narrower. If the two voltages are unbalanced by an excessive amount, the C relay will remain picked up and will prevent synchronizing. Refer to Figure 4.

The C relay drops out at a definite angle before synchronism. The A (Auxiliary Cutoff) relay drops out a definite time after the C relay. The B relay, which picks up at a definite time before synchronism, must pick up after the A relay drops out if the F (Final Auxiliary) relay is to pick up and give a closing signal to the breaker. The lamp signal will not be given if the slip is large enough so that the product of the slip and the sum of the A relay dropout time and the breaker closing time is greater than the dropout angle of the C relay.

SEQUENCE OF OPERATION AT HIGH SLIP FREQUENCY

1. Assume that the machine and bus voltages are 180° out of phase. The C relay will pick up. The B (Level Detector) relay will be dropped out. This will pick up the A relay through the B relay's normally-closed 3-4 contact and the C relay's 5-4 contact.
2. The E (Set-Up) relay will now pick up through the A relay's 4-5 contact and the B relay's 6-7 contact. Once picked up, the E relay seals itself in around the A relay's 4-5 contact by its own 9-10 contact, and also seals in the A relay around the B relay's 3-4 contact by its 8-7 contact.
3. As the phase angle between the machine and bus decreases, the level detector card picks up B; C also drops out, de-energizing A by opening its 4-5 contact. Either B or C may operate first, depending on how the slip is.
4. Relay A has a time delay on dropout, so that A will still be picked up when B opens its 6-5 contact and closes its 6-7 contact. This will de-energize E and E will drop out.
5. When A finally drops out, the circuit of F is not completed because E is dropped out, and its 9-10 contact is open.

SEQUENCE OF OPERATION AT LOW SLIP FREQUENCY

- (1) and (2) are the same as described above for high slip frequency.
3. As the phase angle decreases, C drops out at a definite phase angle, de-energizing A by opening its 4-5 contact.
4. The A drops out after a definite time, closing its 3-4 and 6-7 contacts.
5. As the phase angle decreases still further, the level detector card picks up B at a definite time in advance of synchronism.

6. The 5-6 contact of B opens, de-energizing E, but the 6-7 contact re-energizes it before it has a chance to drop out.
7. The 8-9 contact of B energizes F. F picks up, closing its 4-5 contact, which signals the breaker to close.

CONSTRUCTION

The relay components are mounted in a cradle assembly that is latched into a drawout case when the relay is in operation but can be easily removed when desired. To do this, the relay is first disconnected by removing the connection plug that completes the electrical connections between the case block and the cradle block. To test the relay in its case, this connection plug can be replaced by a test plug. The cover, which is attached to the front of the relay case, contains an interlock arm which prevents the cover from being replaced unless the connection plug has been inserted.

The relay case is suitable for either semi-flush or surface mounting on all panels up to two inches thick, and appropriate hardware is available. For outline and panel drilling dimensions, see Figure 9.

Every circuit in the drawout case has an auxiliary brush, as shown in Figure 8, to provide adequate overlap when the connecting plug is withdrawn or inserted.

RECEIVING, HANDLING AND STORAGE

These relays, when not included as part of a control panel, will be shipped in cartons designed to protect them against damage. Immediately upon receipt of a relay, examine it for any damage sustained in transit. If injury or damage resulting from rough handling is evident, file a damage claim at once with the transportation company and promptly notify the nearest General Electric Sales Office.

Reasonable care should be exercised in unpacking the relay in order that none of the parts are damaged or the adjustments disturbed.

If the relays are not to be installed immediately, they should be stored in their original cartons in a place that is free from moisture, dust and metallic chips. Foreign matter collected on the outside of the case may find its way inside when the cover is removed, and cause trouble in the operation of the relay.

ACCEPTANCE TESTS

Immediately upon receipt of the relay, an inspection and acceptance test should be made to ensure that no damage has been sustained in shipment and that the relay calibration has not been disturbed.

VISUAL INSPECTION

Check the nameplate stamping to ensure that the model number, rating and calibration range of the relay received agree with the requisition. Remove the relay from its

case and check that there are no broken or cracked molded parts or other signs of physical damage, and that all the screws are tight.

MECHANICAL INSPECTION

Operate all components manually to check that each operates easily and correctly.

ELECTRICAL TESTS

The GES21 relays have been carefully adjusted at the factory and no further adjustment should be necessary. If convenient, an operation test should be made by connecting the relay to a generator and checking that the relay is operating correctly by observing the sunchroscope and estimating the correct closing angle. See the section on **PERIODIC CHECKS AND ROUTINE MAINTENANCE** if a more thorough test is desired.

INSTALLATION PROCEDURE

LOCATION

The location should be clean and dry, free from dust and excessive vibration, and well lighted to facilitate inspection and testing.

MOUNTING

The relay should be mounted on a vertical surface. The outline and panel drilling dimensions are shown in Figure 9.

CONNECTIONS

The internal connections are shown in Figure 13A for the type GES21A and Figure 17A for the type GES21B. Typical external connections are shown in Figure 2. The numbering of the relay studs is shown in Figure 9. Note that they are shown back view.

ADJUSTMENTS

It is assumed that the factory adjustments necessary for correct operation have not been disturbed, so this section describes only the adjustments that are used to adapt the relay to the requirements of a particular installation. If the relay adjustments have been disturbed, refer to **SERVICING**.

Only two adjustments are required for installation, one to match the advance time of the relay with the closing time of the synchronizing breaker, and the other to determine the maximum frequency difference at which the relay will give a closing signal.

Advance Time

The advance time adjusting potentiometer is marked by the manufacturer at the timespecified on the requisition, and also at the attainable even tenths of a second in the vicinity of the time specified. The location of these markings is determined

with the aid of special testing equipment which applies an adjustable constant frequency difference and measures the advance time. Recalibration should not be necessary; but, in any case, it cannot ordinarily be done in the field because of the difficulty of measuring frequency difference and relay closing angle or advance time.

The advance time setting should be the same as the measured total closing time of the breaker plus its closing relay under normal conditions. No reduction in synchronizing error due to frequency variations of either source can be obtained by setting the advance time either greater or less than the breaker time.

High Difference Frequency Cutoff

The difference frequency cutoff point is adjusted by the cutoff potentiometer that controls the dropout voltage of the C relay. Turning the potentiometer clockwise increases the difference frequency cutoff point.

The cutoff setting is made by the manufacturer at the value of slip corresponding to the smaller of 45° advance angle or 0.33 Hz slip frequency.

This cutoff setting is identified by the most clockwise mark on the nameplate, and is referred to as the 100% maximum slip setting. Other marks represent cutoff calibrations at 80%, 60% and 40% of the maximum setting.

Before decreasing the cutoff setting, full consideration should be given to the fact that unless the frequency difference between the two sources is adjustable and stable, the chances of synchronizing decrease much faster than in direct proportion to the reduction in cutoff setting. A small difference in cutoff setting may therefore cause a relatively large increase in synchronizing time (exclusive of the time required for adjusting the average frequency difference to 0). As the cutoff setting is decreased, it becomes more sensitive to voltage variations. Settings below 40% are not recommended, because a slight unbalance between the machine and bus voltage will prevent synchronizing. If it is desired to set cutoff below 40%, an IJS relay should be considered.

Although the C relay can be adjusted to give cutoff settings higher than the calibrated 100% maximum, it is not recommended that such a change be made. At frequency differences above the original maximum, the advance time will be somewhat less than the value indicated on the advance adjust rheostat. Also, the increased dropout of C that is necessary for an increased cutoff setting tends to raise the pickup above the maximum applied voltage. If an increase in cutoff setting proves necessary, it should be made with caution, observing carefully the operation in the new zone of higher slips.

The dropout of the C relay is adjusted by the cutoff rheostat. If it is necessary, for any reason, to increase the dropout of the C relay, the pickup should also be checked to be sure that it is less than the minimum value of the sum of the applied values (at 180° phase angle). The maximum pickup is 178 volts, based on each 115 volt source having dropped to 0.80 normal, but local conditions may permit an increase in this value.

Using a synchroscope, make a final operation test as described under the section on **ACCEPTANCE TESTS.**

PERIODIC CHECKS AND ROUTINE MAINTENANCE

A Check of several points should be made at intervals depending on the severity of service; an initial interval of 3 months is recommended. This interval can be increased as indicated by experience under local conditions.

1. Check the tightness of connections and adjustments.
2. Check that all relays have wipe.
3. Check the operating point of the level detector card (see second paragraph under LEVEL DETECTOR in the **SERVICE** section).
4. Check for the correct sequence of operation of the various relay units as described in SEQUENCE OF OPERATION by opening the breaker, disabling the closing circuit, and adjusting the prime mover to apply the desired slip frequency to the relay.
5. Check the pickup and dropout voltages of the C relay unit to see that they have not changed. Measure by applying an adjustable voltage of rated frequency to studs 3 and 6, with 4 and 5 connected together. As the C relay unit must pick up for the GES to operate, its pickup voltage must not be more than the sum of the minimum voltages of the bus and the machine supplies for which the GES relay is expected to operate.
6. Optional Test - To Verify the Advance Angle

If the speed of the generator prime mover can be controlled sufficiently accurately, or if the speed changes slowly, the advance angle can be measured, using an oscillograph. See Figure 11 for the test setup. The 60 Hz bus voltage is connected to the galvanometer producing the uppermost trace. The next trace is the machine voltage, the third is the difference of the first two, and the last is the output contact of the GES relay. Determine the in-phase point by estimating the minimum voltage point on the difference voltage trace. Count the number of cycles of the bus voltage wave between the point where the GES relay output contacts close and the in-phase position. Multiply this number by the period of the bus voltage wave (0.0167 second for 60 Hz). The result is the relay's advance time in seconds. If the relay were without error, this time would equal the value on the nameplate and the breaker's closing time. As the relay's permissible error is in degrees, the measured advance time should be converted to degrees by multiplying it by 360 and dividing the result by the period of the envelope in the difference voltage wave. This period can be measured by counting the number of bus voltage cycles between null points of the difference voltage wave and dividing by the frequency of the bus voltage wave.

$T = NP$
where

T = the relay advance time in seconds

N = number of cycles of the reference voltage wave between the point where the relay output contact closes and the in-phase position.

P = The period of the reference voltage wave of $1/f$ (the frequency in hertz)

$$D = T \times 360/P_s = N \times P \times 360/P_s$$

D is the relay advance angle in degrees

P_s is the period of the envelope of the difference voltage wave in seconds.

A sample oscillogram is shown in Figure 12.

7. For cleaning telephone relay contacts, a flexible burnishing tool should be used. This consists of a flexible strip of metal with an etched-roughened surface, resembling in effect a superfine file. The polishing action is so delicate that no scratches are left, yet corroded material will be removed rapidly and thoroughly. The flexibility of the tool ensures the cleaning of the actual points of contact. Sometimes an ordinary file cannot reach the actual points of contact because of some obstruction from some other part of the relay.

Telephone relay contacts should not be cleaned with knives, files, or abrasive paper or cloth. Knives or files may leave scratches which increase arcing and deterioration of the contacts. Abrasive paper or cloth may leave minute particles of insulating abrasive material in the contacts and thus prevent closing.

The burnishing tool described above can be obtained from the factory.

SERVICING

The Type GES21 relay has been adjusted at the factory, but if a check shows that the adjustments have subsequently been disturbed, the following points should be observed in restoring them:

LEVEL DETECTOR CARD

The following adjustment on the level detector card is a preliminary test to determine if the card is functioning and to make an approximate setting. The final setting of the card is performed in the GES relay, where the card is adjusted to give an output (pickup of B relay) 2° to 4° in advance of 0° and remain picked up through 0° and for 2° to 4° after 0° . This test is performed at very low slip cycles and at balance rated voltages.

To check or adjust the level detector card operating point, connect the test setup shown in Figure 10. With rated control voltage applied, check that the B relay picks up just before pin 7 becomes positive with respect to pin 3. The desired point is 150 millivolts negative \pm 50 millivolts. Some chatter or pumping just at the operating point is normal, but it should be limited to a range of less than 25 millivolts. Dropout should be no more than 50 millivolts from pickup.

If the B relay is picked up when the level detector input is shorted (connect pin 7 to pin 3), the card has been set to pick up at 150 millivolts positive rather than negative. If the card is set to pick up at a voltage higher than the correct value, the B relay will not operate at low slips (below 0.05 Hz) when balanced AC voltages are used. With unbalanced voltage the B relay may still operate at low slips if the compensation adjustment is also incorrectly set. If the card is set to pick up at a voltage lower than the correct value, then the advance angle will increase as the slip decreases below 0.05 Hz to values in excess of 50 with balanced voltages. A properly adjusted relay will close between 20° and 40° before 0° at 0.02 Hz with balanced voltages.

The setting of the level detector card does not have to be changed when the breaker time setting is being changed. The card setting has its greatest effect on the relay at low slips. When the relay is in correct adjustment, the B relay may or may not be picked up when the two AC voltages are balanced and in phase. If the relay performs correctly between 0.05 Hz and 0.02 Hz as described above, the level detector is correctly adjusted and it should not be changed to make the B relay pick up when the two voltages are standing in phase.

SETTING AN ADVANCE TIME

The breaker advance time is ordinarily set in the factory at the time the relay is made. Because the special test equipment used in the factory is usually not available elsewhere, it is in general advisable to return the relay to the factory for recalibration.

The adjustment procedure is given below for those times when it is not convenient to return the relay to the factory. An ideal test setup includes a digital timer and a variable speed motor-driven phase shifter with a contact which closes at the in-phase position. Other test setups will usually have to be used, as dictated by the available equipment and with a corresponding increase in the time required.

When setting an advance time there are three interacting settings which must be made together. These are the advance transformer primary taps, the advance potentiometer setting, and the saturating reactor taps. To begin, apply rated voltage to both AC inputs with a slip which is 2/3 to 3/4 of the desired cutoff slip. Set the voltage unbalance compensating potentiometer fully counterclockwise. Set the saturating reactor for short breaker times if the desired time is below 300 milliseconds, to medium if between 300 and 600, and to long if above 600 milliseconds. Refer to Figure 7 for advance transformer and saturating taps.

Try each set of advance transformer taps in turn and on each tap attempt to adjust the advance adjusting potentiometer to obtain the desired advance time. It should be possible to obtain the desired advance time on several taps. Using a tap which is

midway among the several found above, perform the following two adjustments. First, set the desired advance time with balanced voltages and at 2/3 to 3/4 of the desired cutoff slip as above. Second, at a slip of 0.02 Hz and with one voltage at 110% of rating and the other at 80% of rating, adjust the voltage unbalance compensating potentiometer until the relay gives a closing signal from 20 to 40 before the in-phase position. This will affect the advance time set in the first adjustment, so now go back and readjust. Continue alternating between these two adjustments until the relay passes both tests. Now, using balanced voltages, plot a curve like that in Figure 16. The maximum difference between the plotted curve and the theoretically perfect straight line at any point must not exceed $\pm 5^\circ$. If this is not true, choose another combination of taps on the advance transformer and try again to calibrate the relay. If none of the usable advance transformer tap combinations will allow the relay to be calibrated, it will be necessary to try another set of taps on the saturating reactor, make a new list of possible advance transformer taps, and try each of them as described.

When making the above adjustments the following points of information may be helpful. The level detector card adjustment and the unbalanced voltage compensation adjustment affect principally the low end of the curve below 0.05 hertz. The advance transformer taps and the saturating reactor taps affect principally the middle and upper part of the curve. A very sharp decrease in advance time just before cutoff is caused by an incorrectly adjusted E (Set-Up) relay. It can be temporarily suppressed by increasing the cutoff setting during testing, and will be cured by correct adjustment of the E relay.

SETTING CUTOFF

No attempt should be made to set cutoff until the advance time setting is satisfactory, as any change in the advance time setting will strongly affect the cutoff setting. Refer to HIGH DIFFERENCE FREQUENCY CUTOFF in the **ADJUSTMENTS** section for considerations involved in picking a cutoff setting.

Apply balanced rated voltages with the slip frequency at which it is desired to set cutoff, and adjust the cutoff rheostat until the relay just fails to give a closing signal. Drop the slip frequency 0.02 Hz and the relay should give a closing signal each slip cycle.

TELEPHONE RELAYS

Adjustments Common to All Telephone Relays

1. With telephone relays in the de-energized position, all open contacts should have a gap of 0.015 inch and all closed contacts should have a minimum overtravel of 0.005 inch. Gap may be checked by inserting a feeler gage and wipe can be checked by observing the amount of deflection on the stationary contacts before the contacts part. The armature should then be operated by hand and the gaps and wipes in the picked-up position measured, as above.
2. Telephone relay contact gaps may be readjusted by bending the stationary contact brush to obtain the 0.015 inch gap. After the gap is adjusted, the overtravel should be checked to be a minimum of 0.005 inch and adjusted by bending the moving contact brush as required.

Adjustments Not Common To All Relays

Relay A

The dropout time of the A relay should be approximately 1/4 of a second. This is adjusted by R19, the rheostat on the rectifier board (upper right hand side) and by the residual screw and gap between the armature and the frame on the A relay itself.

Relay B.

Adjust the residual screw to give about 2 mils armature gap in the energized position, and lock the adjustment. Check that the gap between the armature and the frame is about 5 mils in the energized position.

Relay E

Check that the gap between the armature and the frame is a minimum of 5 mils in the energized position. Adjust the residual screw so that when operating at minimum DC control voltage (0.8 normal), E starts to drop out when B picks up (electrically), but holds in. An occasional failure to hold in at the minimum voltage is permissible and indicates correct adjustment.

RENEWAL PARTS

Sufficient quantities of renewal parts should be kept in stock for the prompt replacement of any that are worn, broken or damaged.

When ordering renewal parts, address the nearest Sales Office of the General Electric Company. Specify the name of the part wanted, quantity required, and complete nameplate data, including the serial number, of the relay.

GEK-27919

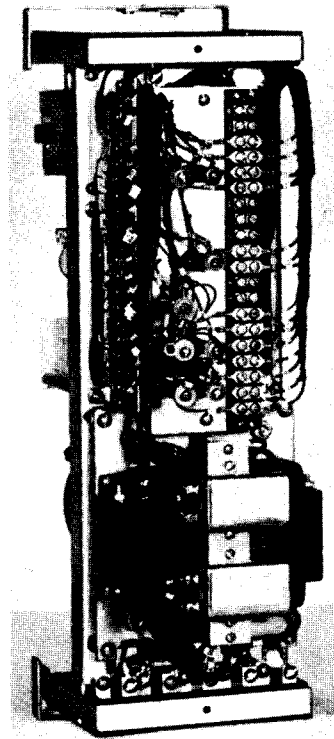

8041527
Rear View

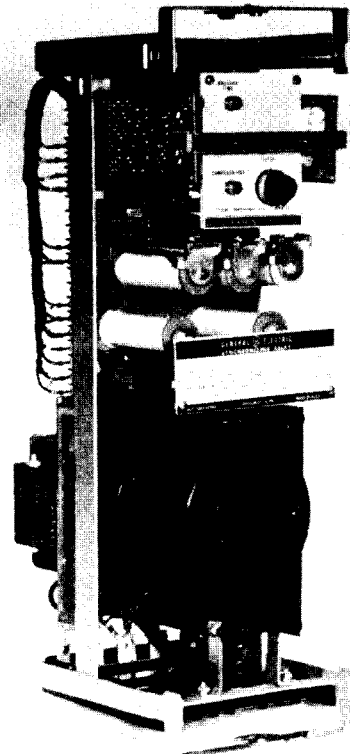

8041526
Right View

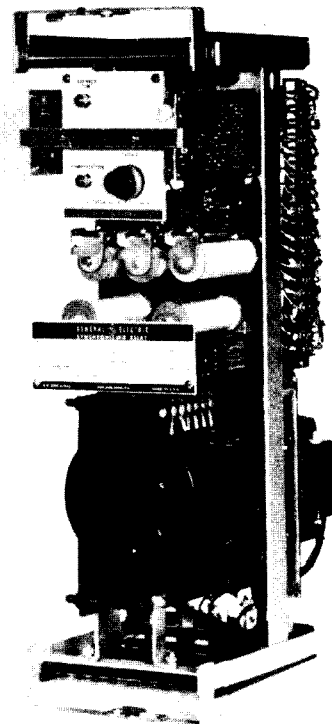

8041525
Left View

Figure 1 - Type GES21A Relay Removed from Drawout Case

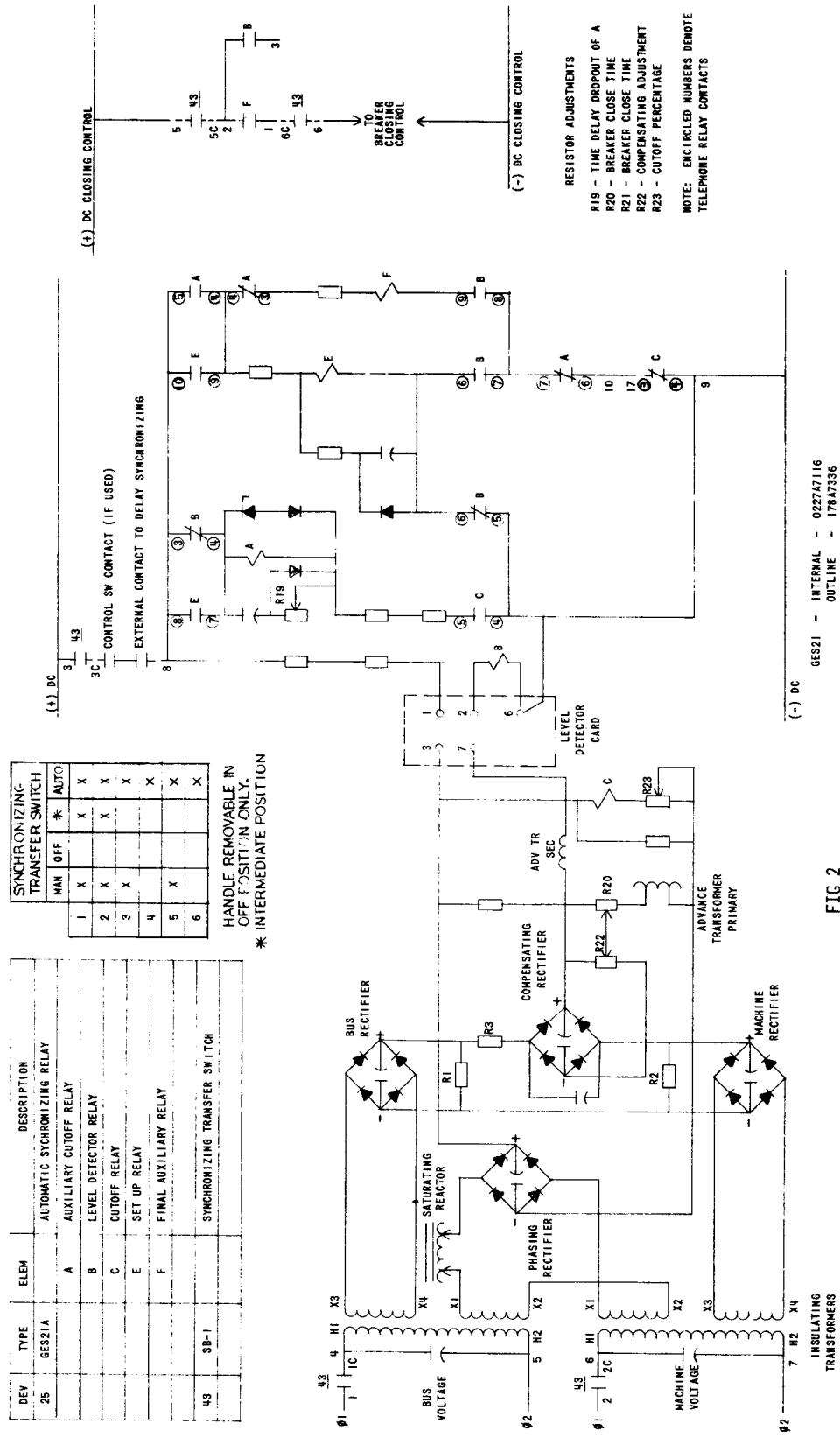

SYNCHRONIZING TRANSFER SWITCH		
MAN	OFF	AUTO
1	X	X
2	X	X
3	X	X
4	X	X
5	X	X
6	X	X

HANDLE REMOVABLE IN OFF POSITION ONLY.
* INTERMEDIATE POSITION

DEV	TYPE	ELEM	DESCRIPTION
25	GES21A	A	AUTOMATIC SYNCHRONIZING RELAY
		B	AUXILIARY CUTOFF RELAY
		C	LEVEL DETECTOR RELAY
		E	CUTOFF RELAY
		F	SET UP RELAY
			FINAL AUXILIARY RELAY
43	SB-1		SYNCHRONIZING TRANSFER SWITCH

RESISTOR ADJUSTMENTS
R19 - TIME DELAY DROPOUT OF A
R20 - BREAKER CLOSE TIME
R21 - BREAKER CLOSE TIME
R22 - COMPENSATING ADJUSTMENT
R23 - CUTOFF PERCENTAGE

NOTE: ENCIRCLED NUMBERS DENOTE TELEPHONE RELAY CONTACTS

FIG 2

Figure 2 (0165B2597-1) Elementary Diagram for GES21A Relay

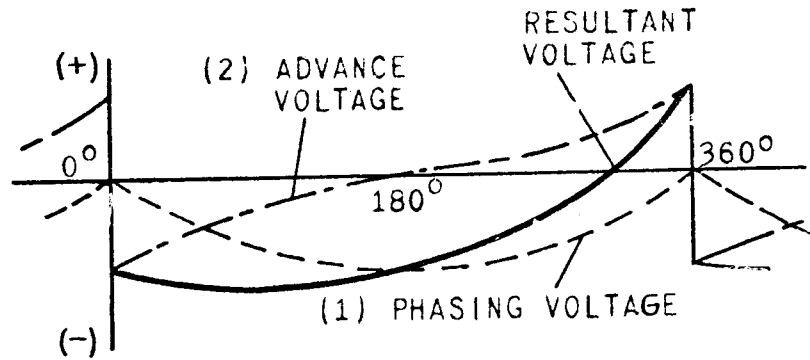

FIG. A - COMPONENTS OF VOLTAGE THAT CONTROLS B WHEN VOLTAGES ARE BALANCED.

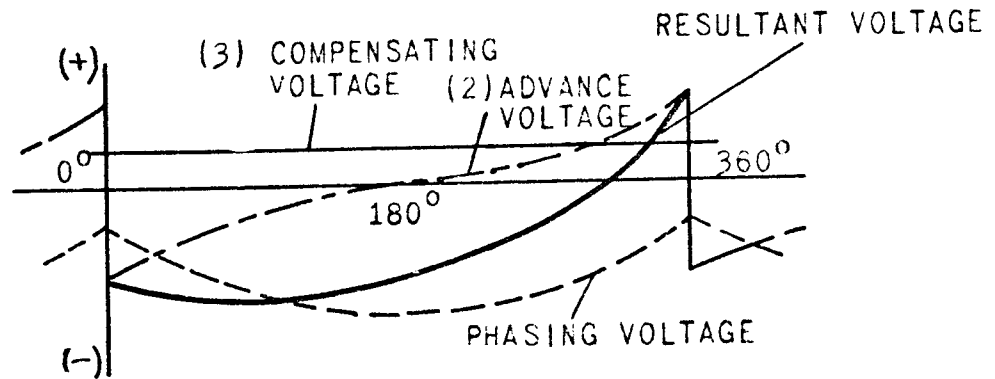

FIG B - COMPONENTS OF VOLTAGE THAT CONTROLS B WHEN VOLTAGES ARE UNBALANCED.

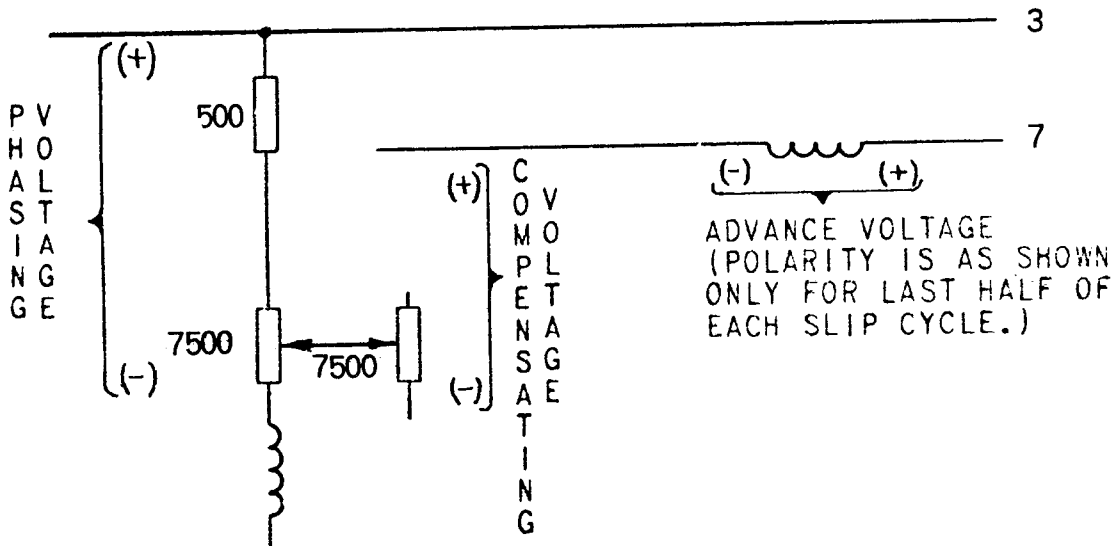
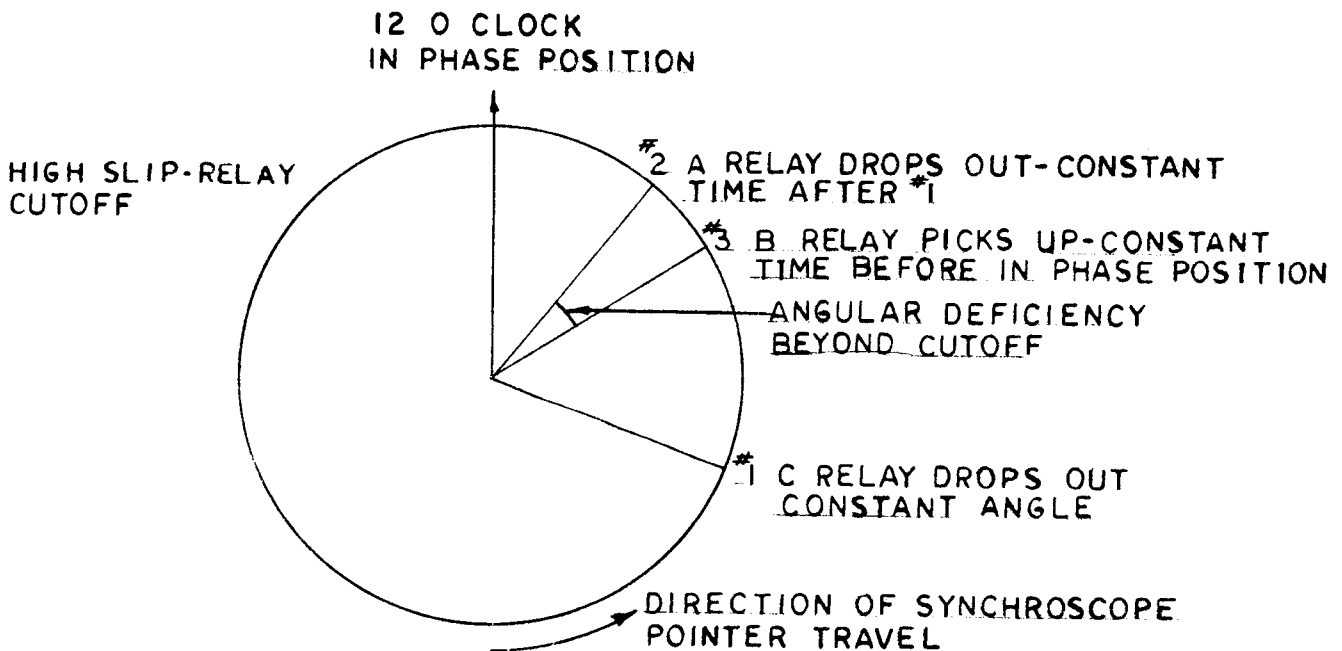
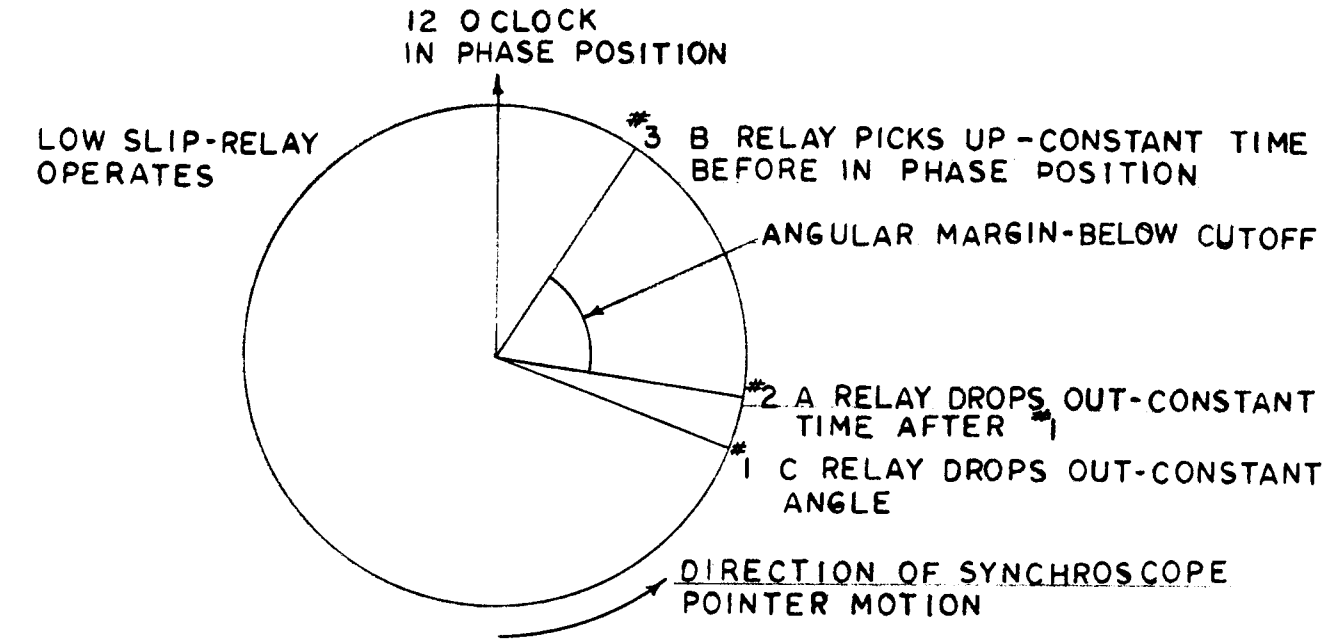

FIG. C - COMPONENTS OF VOLTAGE THAT CONTROLS B RELAY.

Figure 3 (0246A3303-0) Components of Voltages that Control B Relay



BOTH FIGURES DRAWN FOR CASE WHEN MACHINE FREQUENCY IS BELOW SYSTEM FREQUENCY

Figure 4 (0246A3809-0) Synchronoscope Diagram Showing Sequence of Operation

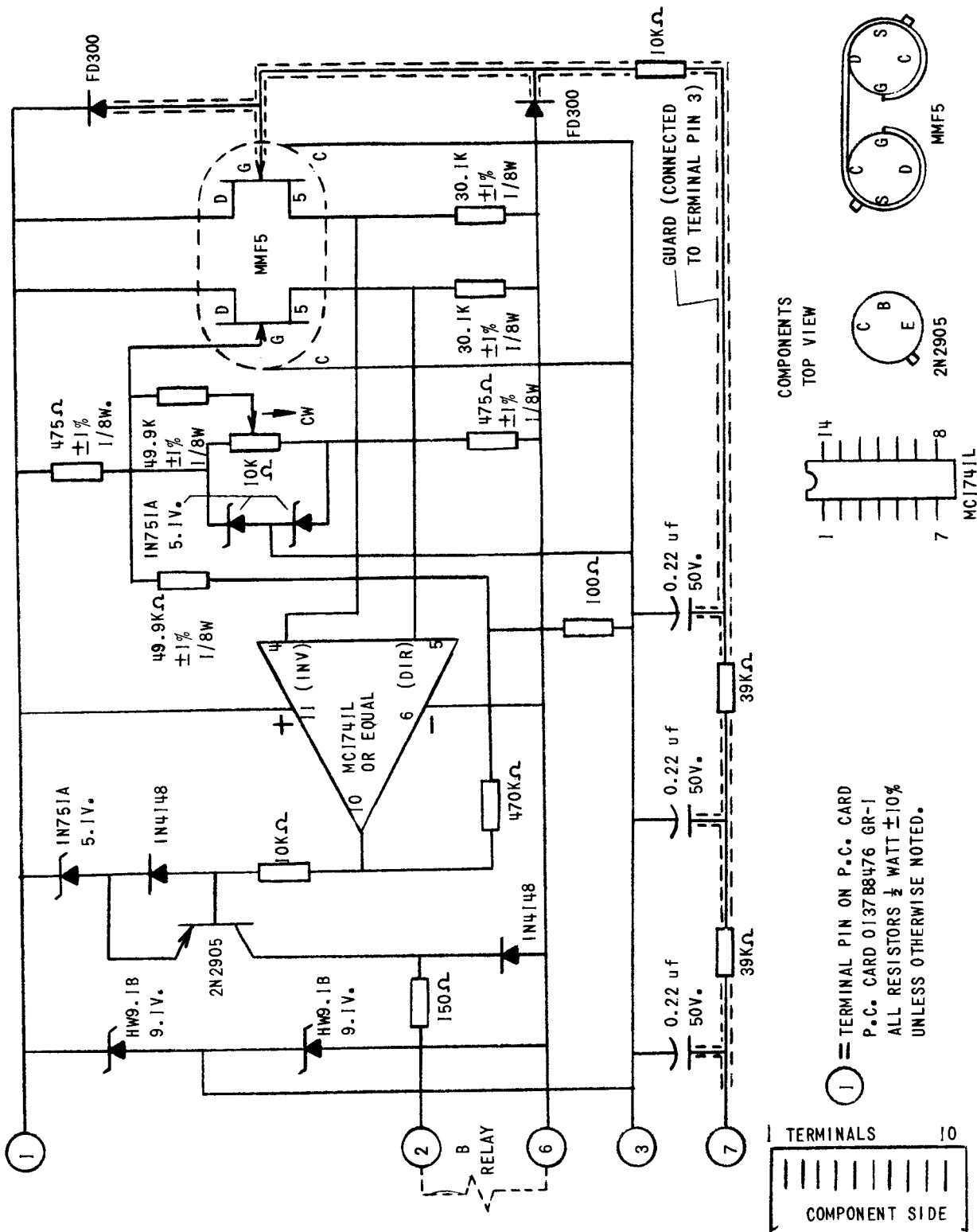

Figure 5 (0226A7241-1) Internal Connections of Level Detector Card

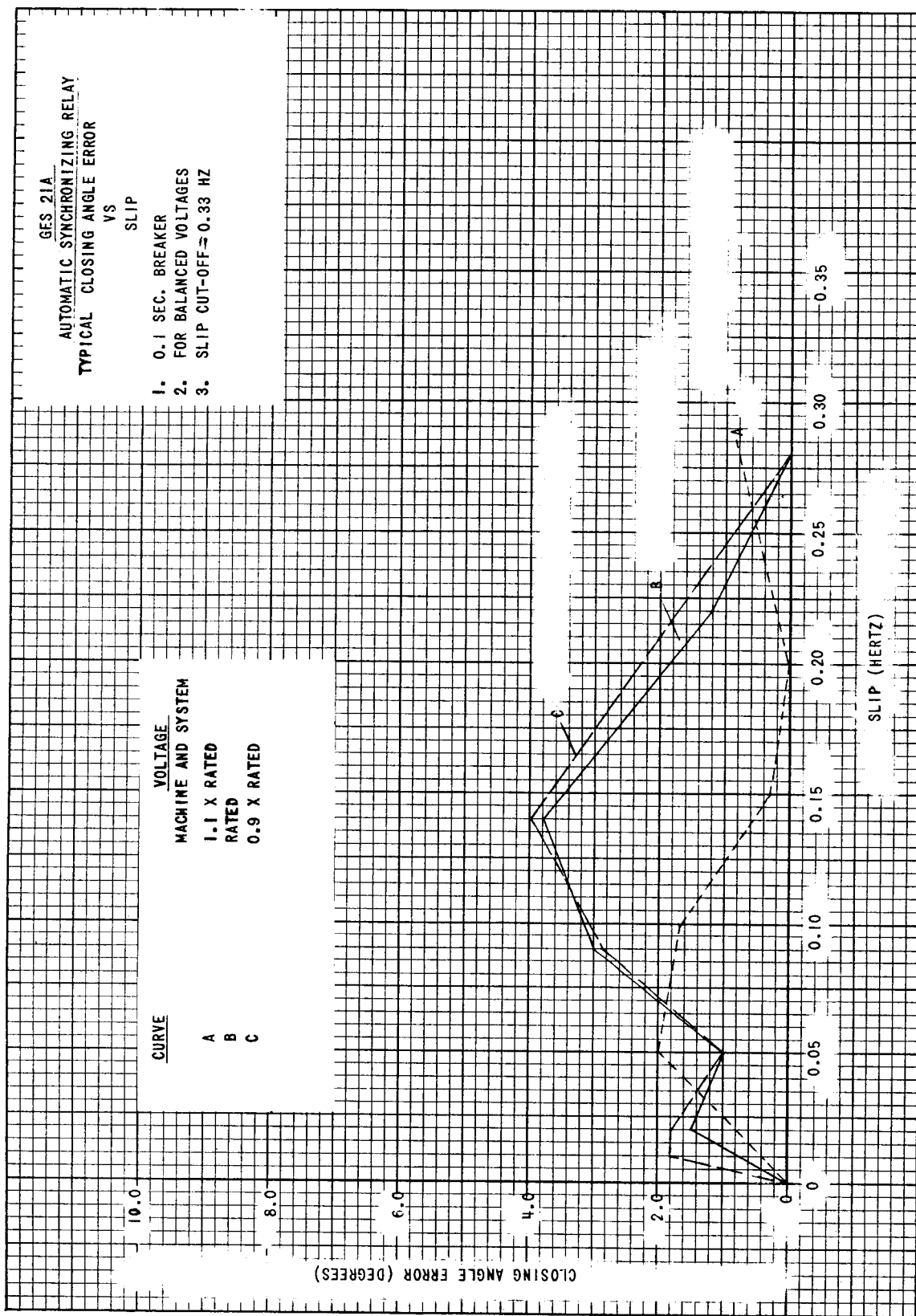

Figure 6A (0246A3825-0) Typical Closing Angle Error VS Slip for Balanced Voltages and 0.1 Second Breaker

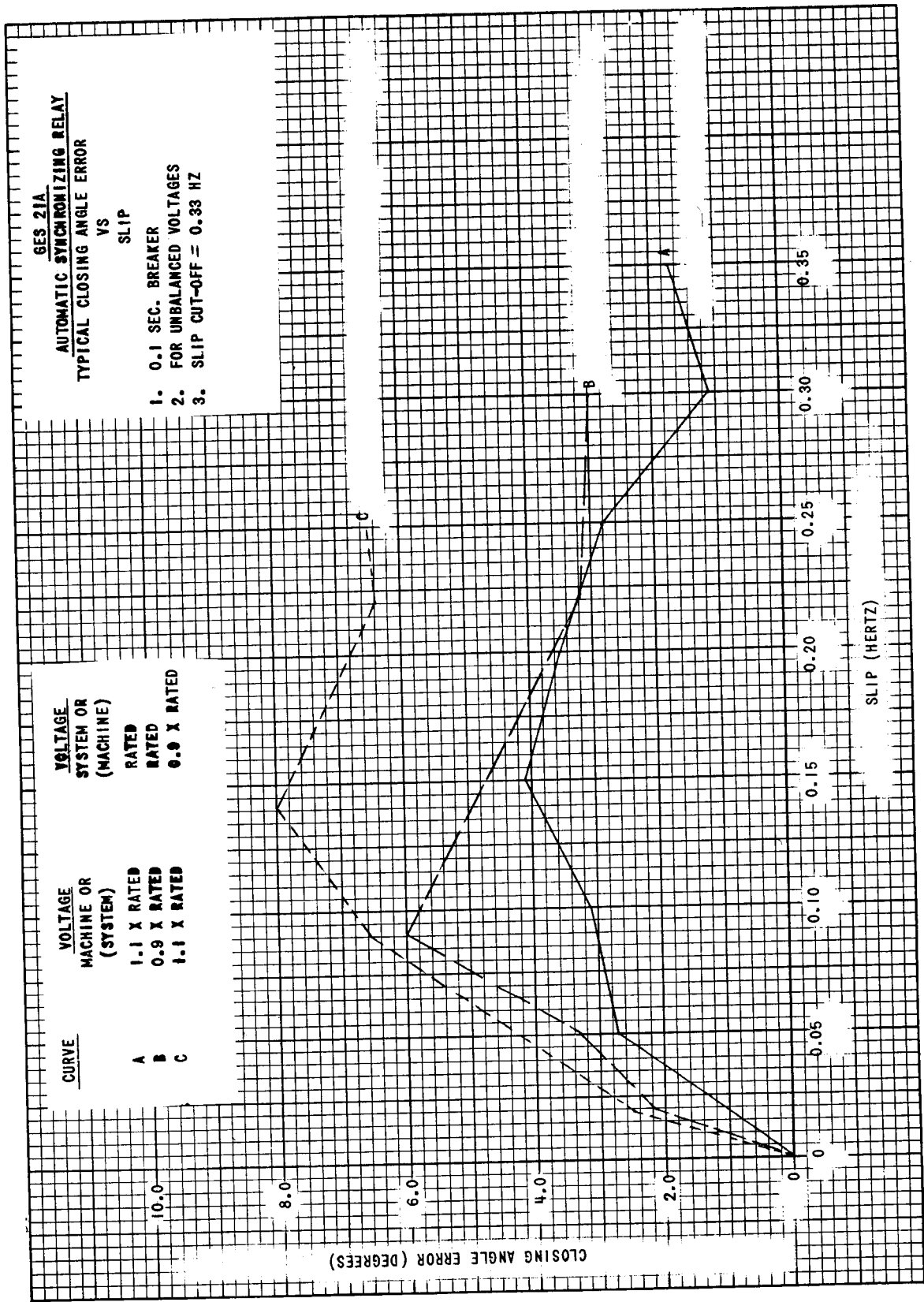

Figure 6B (0246A3826-0) Typical Closing Angle Error VS Slip for Unbalanced Voltages and 0.1 Second Breaker

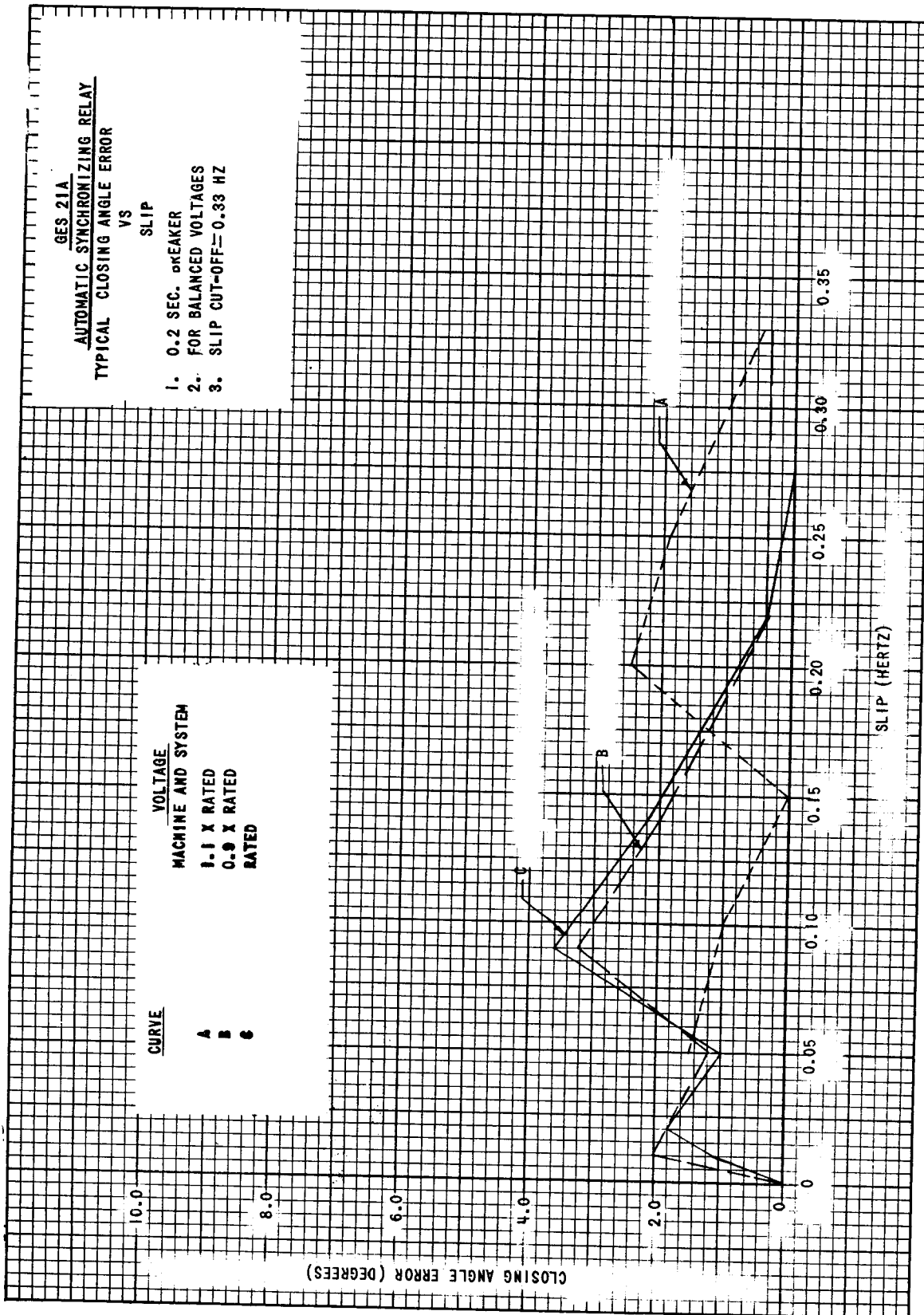

Figure 6C (0246A3827-0) Typical Closing Angle Error VS Slip for Balanced Voltages and 0.2 Second Breaker

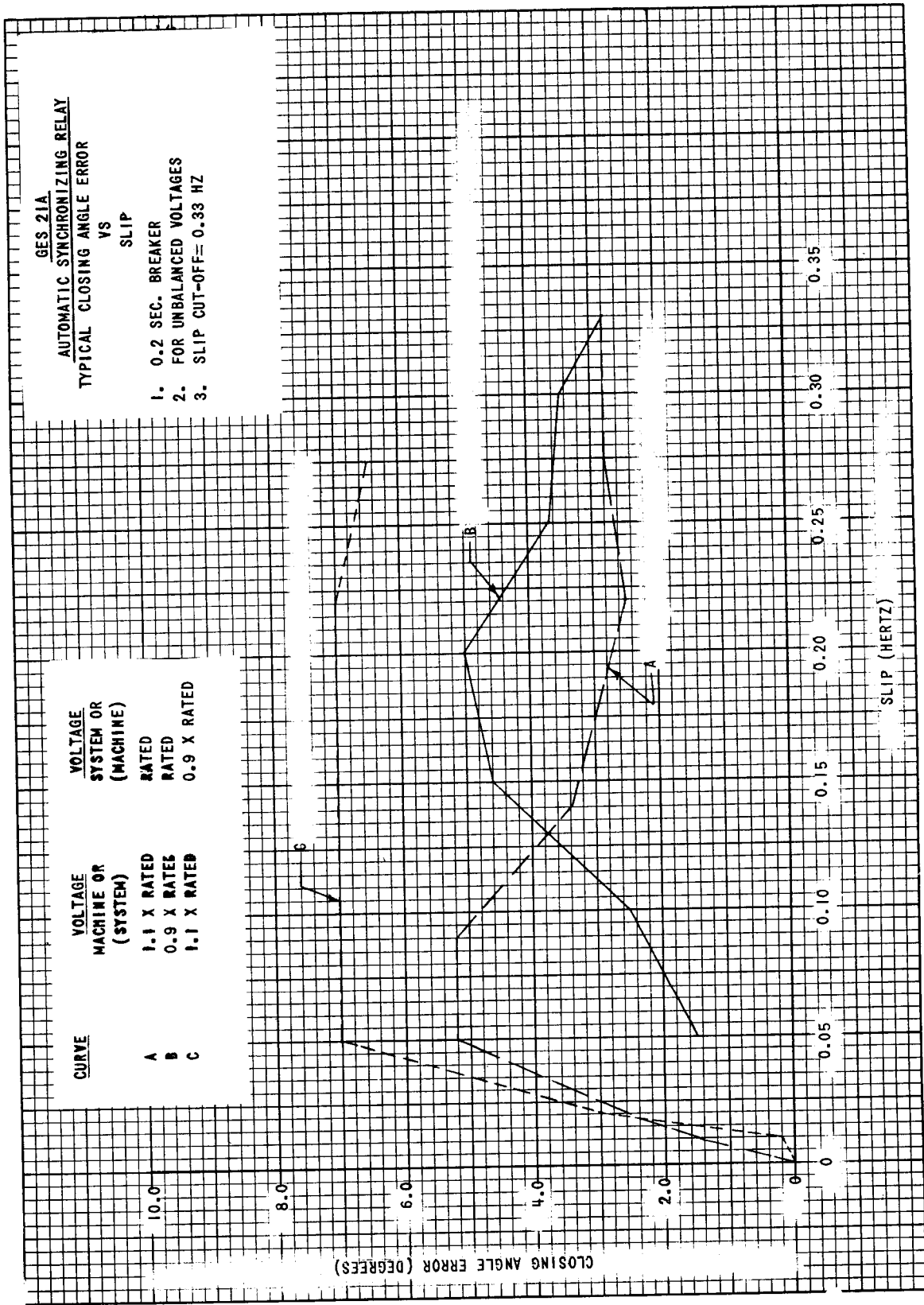
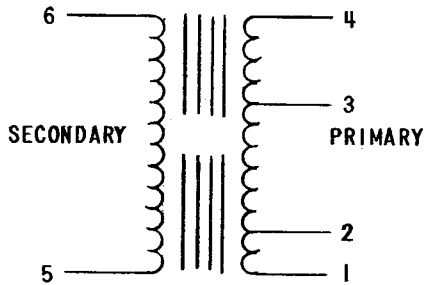

Figure 6D (0246A3828-0) Typical Closing Angle Error VS Slip for Unbalanced Voltages and 0.2 Second Breaker

ADVANCE TRANSFORMER



AVAILABLE WINDING COMBINATIONS

PRIMARY WINDING TAPS	FRACTIONAL PART OF WINDING
1-2	1/6
3-4	1/3
2-3	1/2
1-3	2/3
2-4	5/6
1-4	FULL

SHORT BREAKER TIMES USE SMALLER SECTIONS OF PRIMARY WINDING.

SATURATING REACTOR

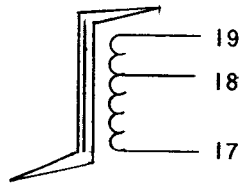

- USE 19-18 FOR SHORT BREAKER TIMES
- USE 18-17 FOR MEDIUM BREAKER TIMES
- USE 19-17 FOR LONG BREAKER TIMES

Figure 7 (0246A7944-0) Advance Transformer and Saturating Reactor Tap Connections

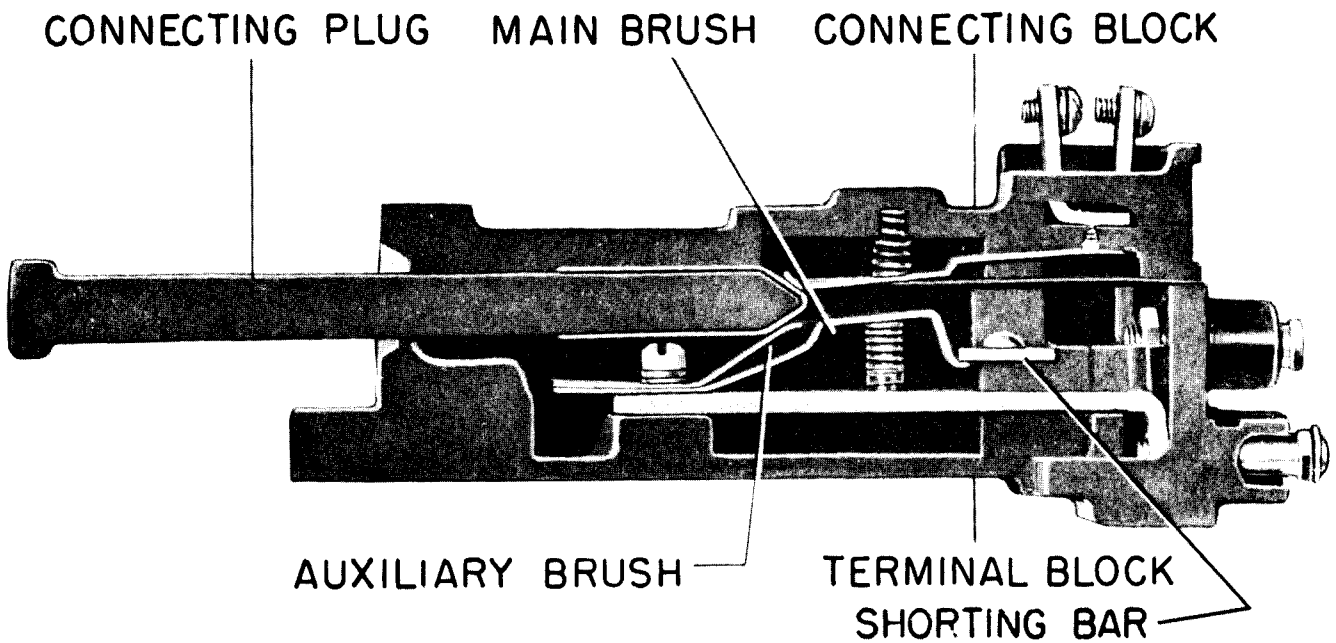

NOTE: AFTER ENGAGING AUXILIARY BRUSH, CONNECTING PLUG TRAVELS 1/4 INCH BEFORE ENGAGING THE MAIN BRUSH ON THE TERMINAL BLOCK

Figure 8 (8025039) Cross Section of Drawout Case Showing Position of Auxiliary Brush and Shorting Bar

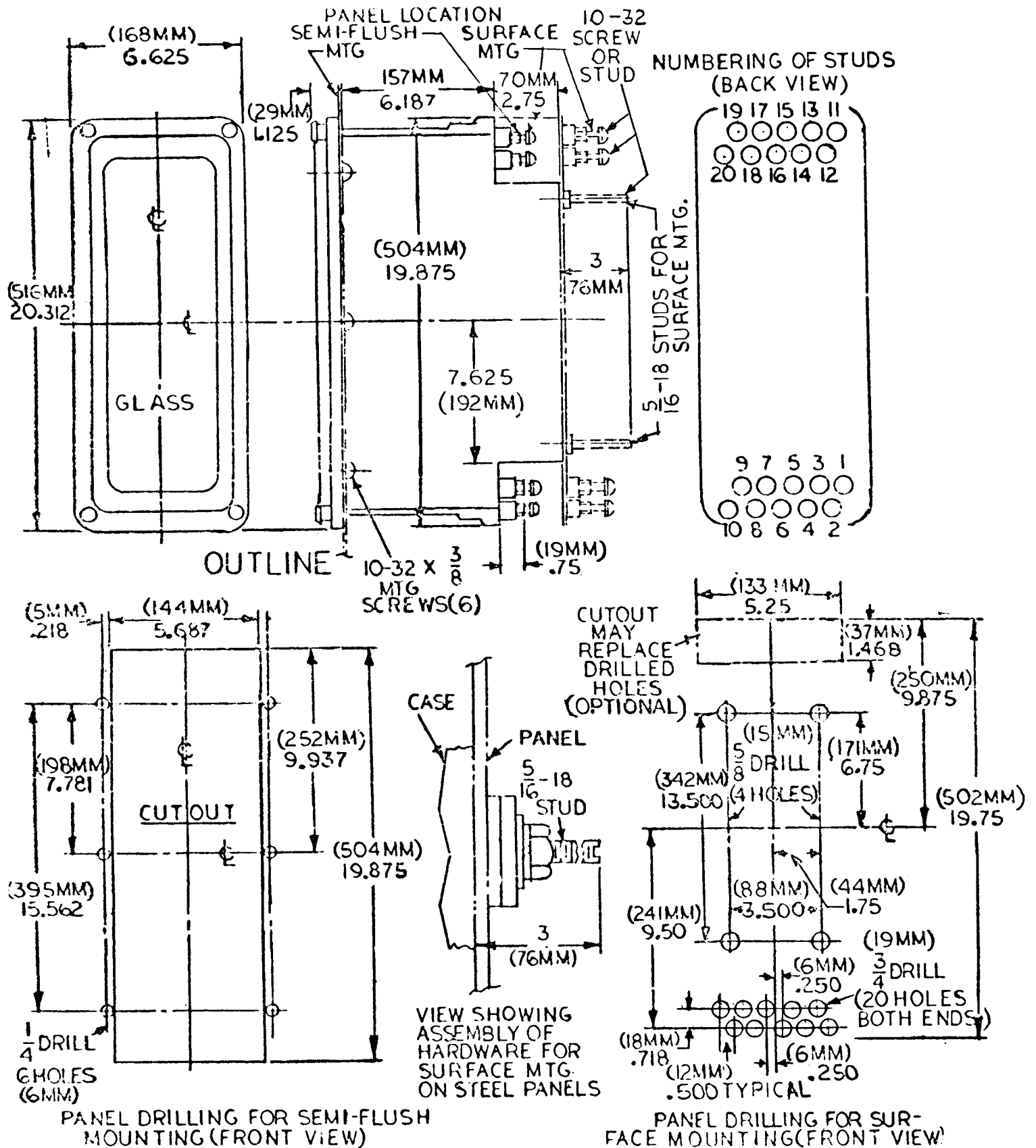
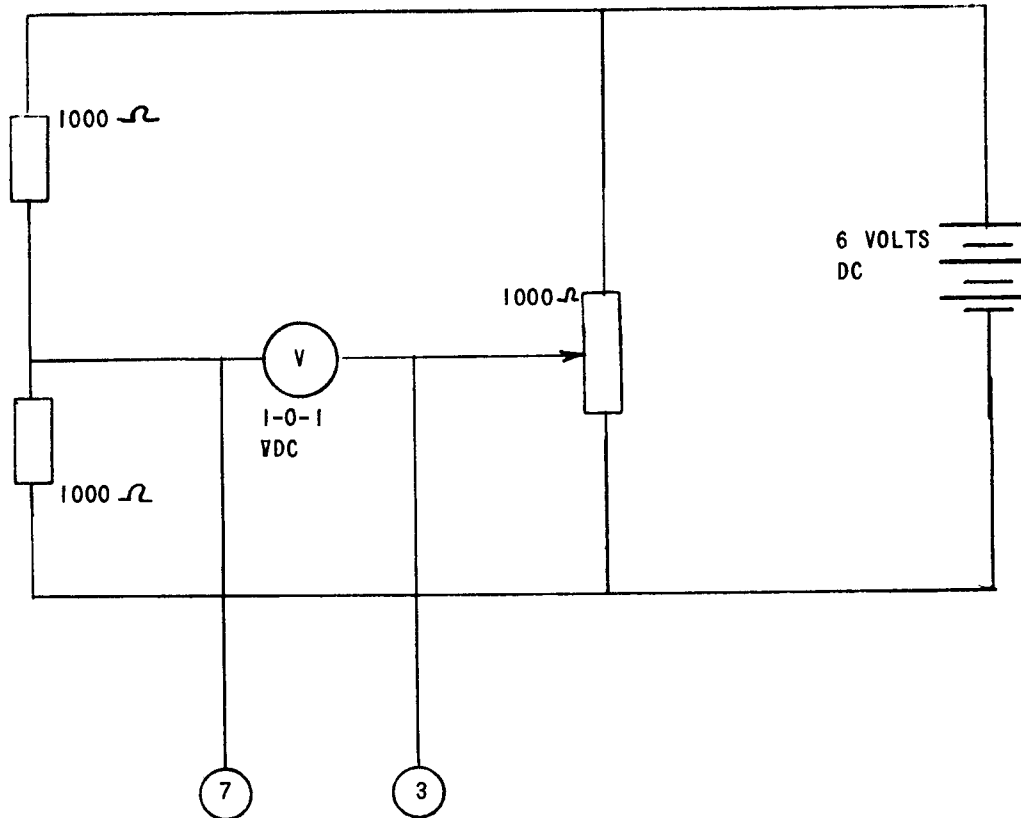

Figure 9 (0178A336-4) Outline and Panel Drilling Dimensions for L2D Size Case



NOTES

1. THE ENCIRCLED NUMBERS REFER TO THE PRINTED CIRCUIT CARD CONNECTOR
2. IT IS NOT NECESSARY TO REMOVE ANY CONNECTIONS TO THE CARD CONNECTOR
3. D C CONTROL VOLTAGE SHOULD BE APPLIED TO THE RELAY
4. THE OPERATION OF THE CARD IS INDICATED BY THE OPERATION OF B RELAY.

Figure 10 (0246A3395-0) Test Connection Diagram for Measuring the Level Detector Card Operating Point

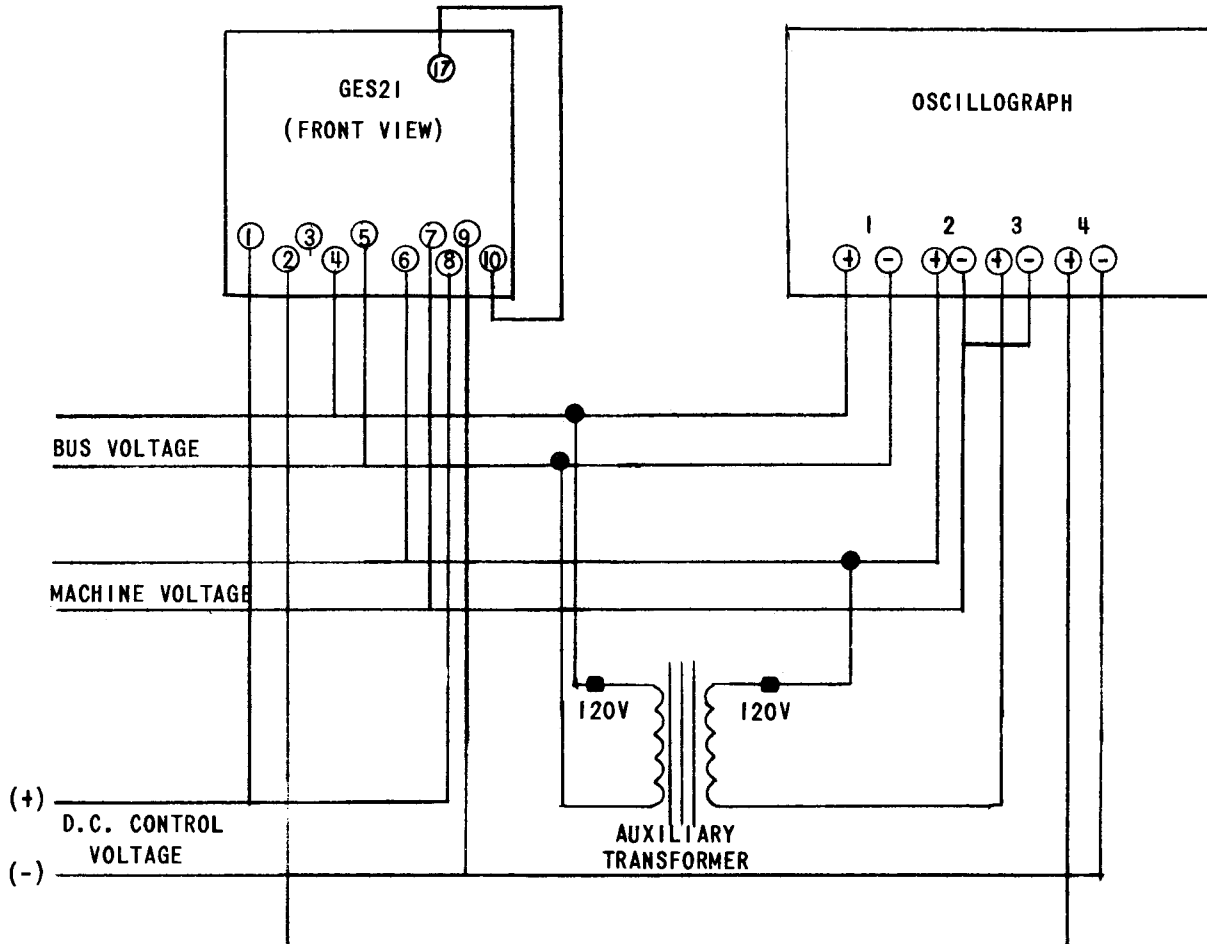

Figure 11 (0246A3394-1) Test Connection Diagram for Measuring the Relay Advance Angle

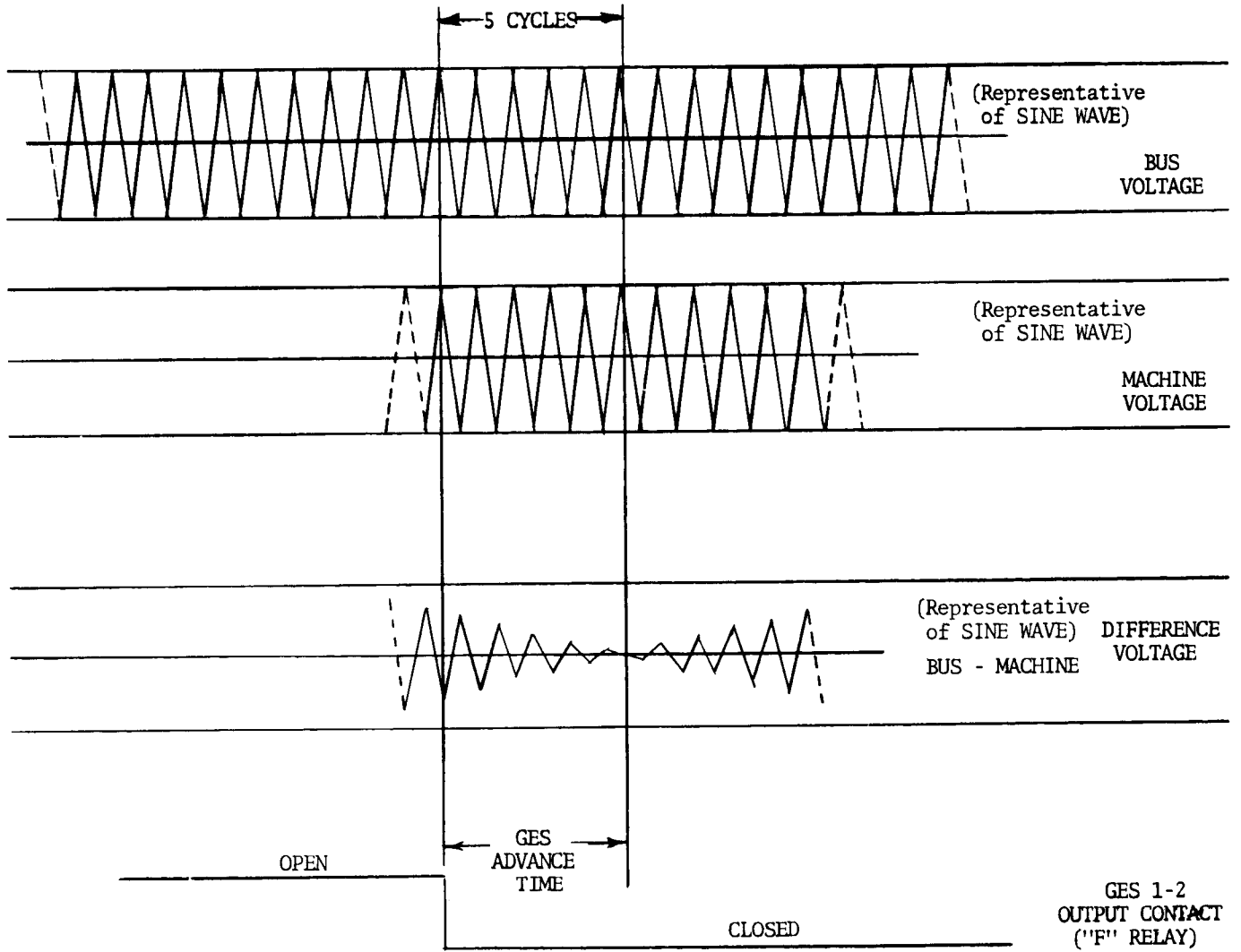

Figure 12 (0246A3784-0) Typical Oscilloscope Output for Measuring Relay Advance Output

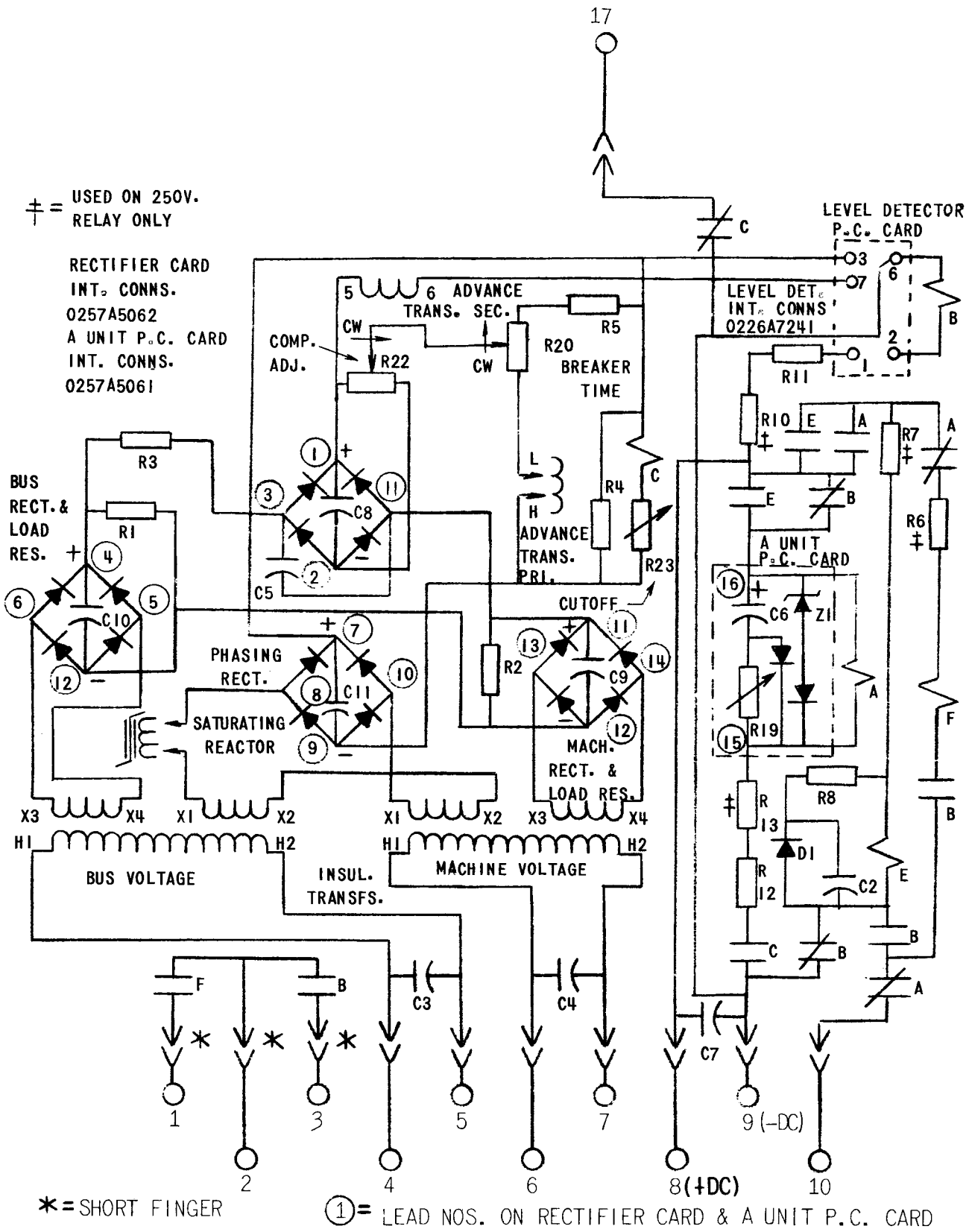
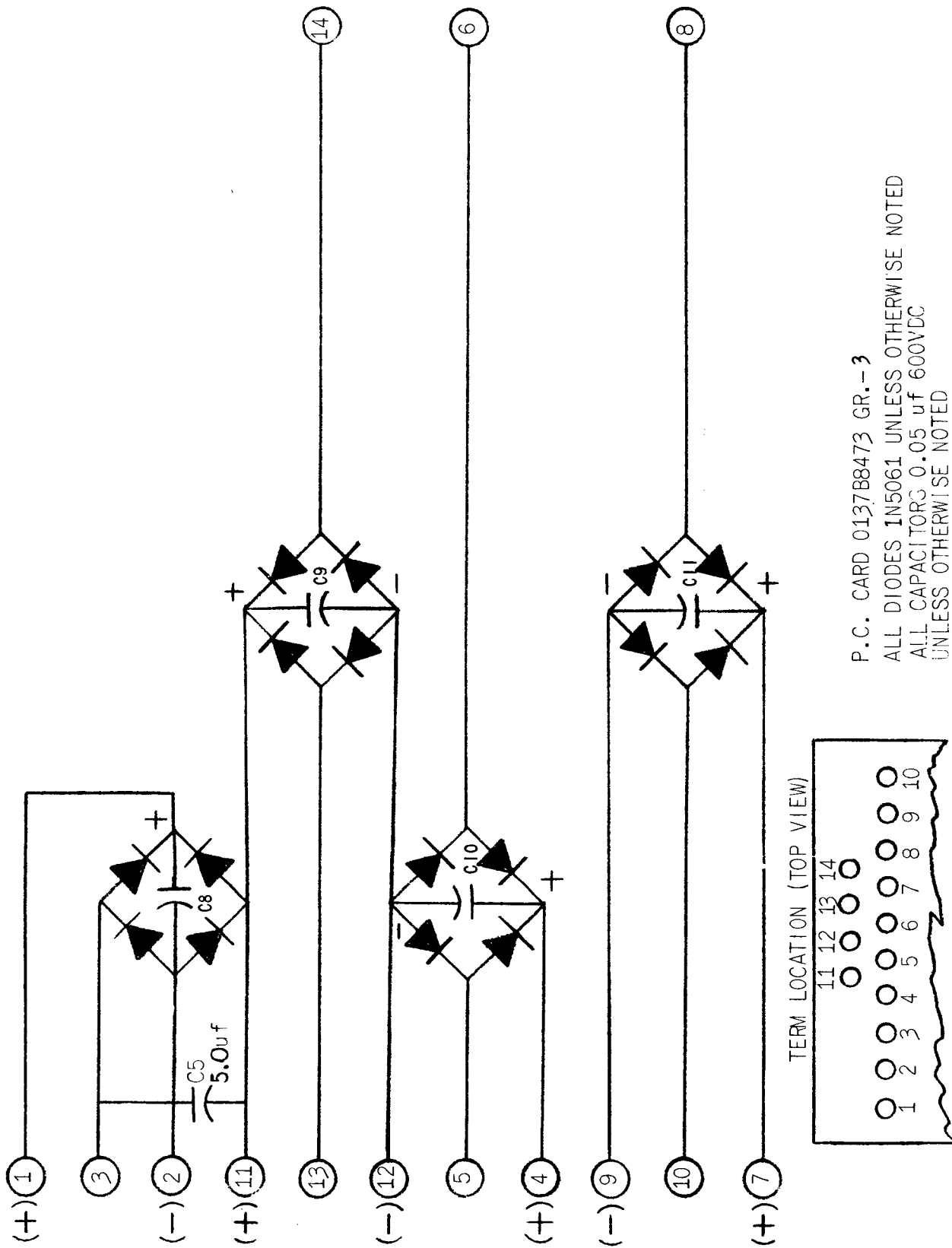

Figure 13A (0227A7116-4 Sheet 1) Internal Connection Diagram for GES21A Relay (Front View)

MODEL	FORM	
12GES21A(-)D	1 THRU 4	5 THRU 8
VOLTS D.C.	125	250
RESISTANCE IN OHMS		
A COIL	2500	2500
B COIL	400	400
C COIL	2500	2500
E COIL	5000	5000
F COIL	5000	5000
R1	1500	1500
R2	1500	1500
R3	3000	3000
R4	2500	2500
R5	500	500
R6	NONE	5600
R7	NONE	5600
R8	500	500
R10	NONE	1750
R11	1500	1500
R12	4000	4000
R13	NONE	4000
R19	10,000	10,000
R20	7500	7500
R22	7500	7500
R23	50,000	50,000
CAPACITANCE VALUE		
C2	0.25uf	0.25uf
C3	0.50uf	0.50uf
C4	0.50uf	0.50uf
C5	5.0uf	5.0uf
C6	180uf	180uf
C7 THRU C11	0.05uf	0.05uf

Figure 13B (0227A7116-4 Sheet 2) Internal Connection Diagram for GES21A Relay



P.C. CARD 0137B8473 GR.-3
 ALL DIODES 1N5061 UNLESS OTHERWISE NOTED
 ALL CAPACITORS 0.05 uF 600VDC
 UNLESS OTHERWISE NOTED

Figure 14 (0257A5062-0) Internal Connections of Rectifier Board

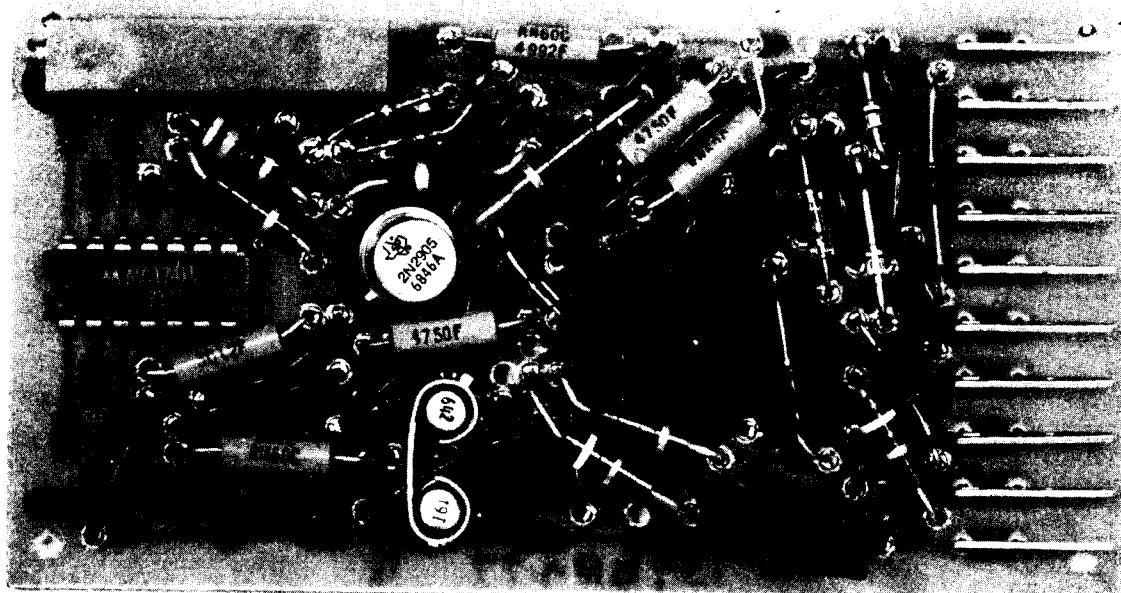

Figure 15 (8041525) Level Detector Printed Circuit Board

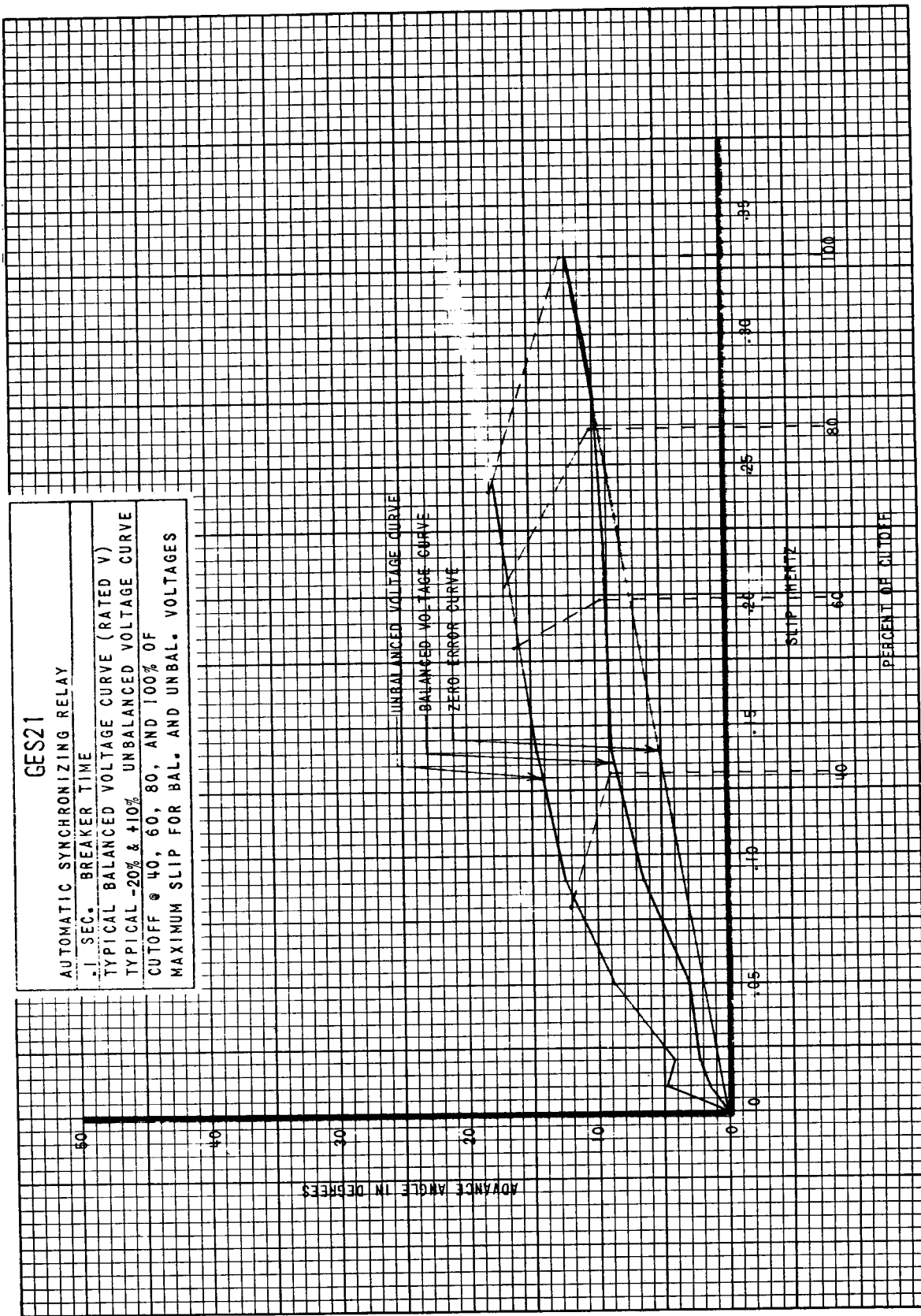

Figure 16 (0246A3762-0) Typical Advance Angle Vs Slip Curves for a GES21A Relay

CONNECT BETWEEN STUDS
16 AND 13 FOR SHORT
BREAKER TIME.
NO STUD CONNECTIONS
FOR LONG BREAKER
TIME.

⊕ = USED ON 250V.
RELAY ONLY

RECTIFIER CARD
INT. CONNS.
0257A5062
A UNIT P.C. CARD
INT. CONNS.
0257A5061

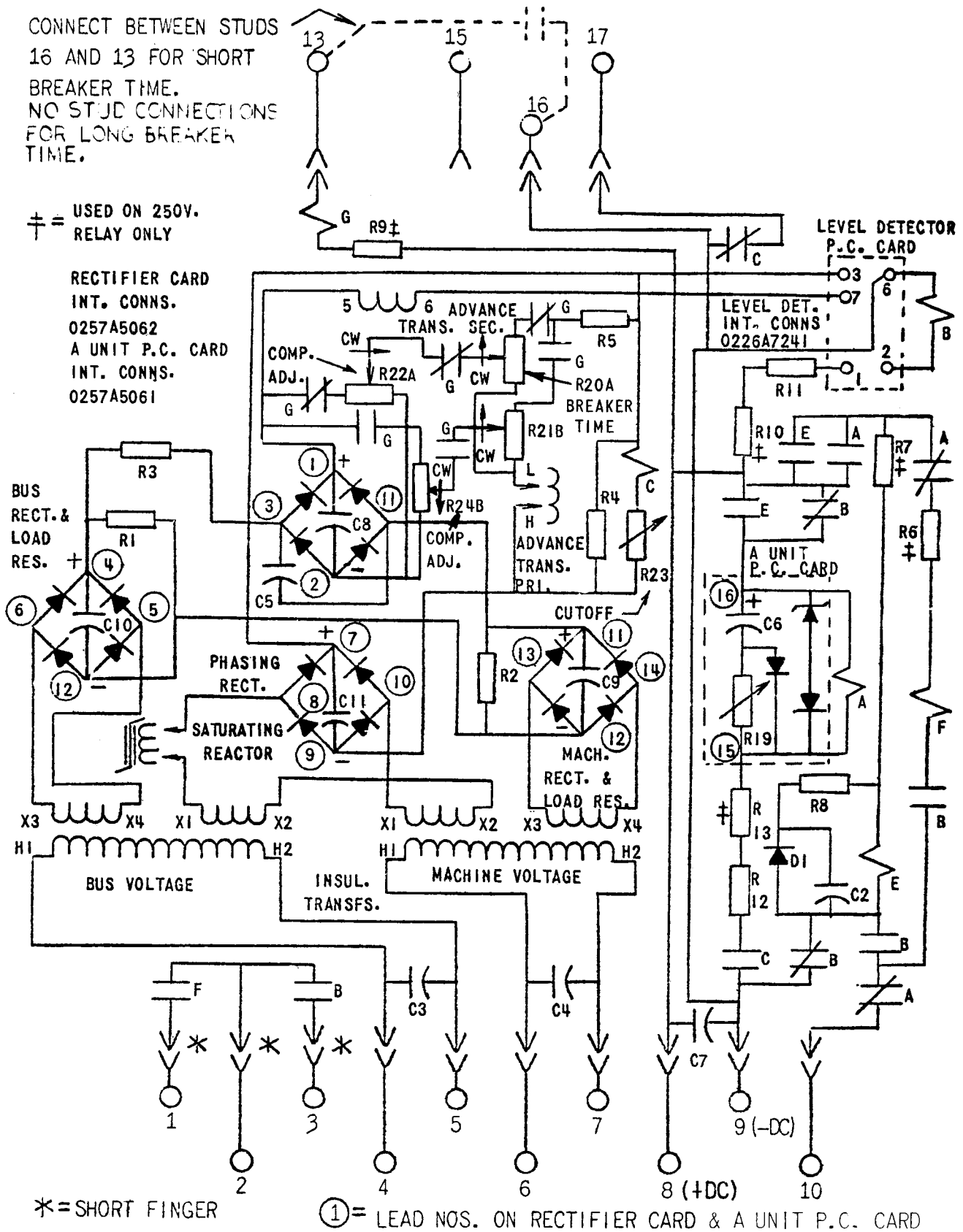
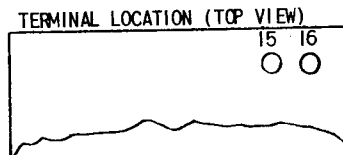
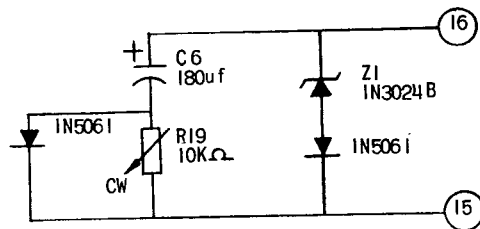

Figure 17A (0226A7239-6 Sheet 1) Internal Connection Diagram for GES21B Relay (Front View)

GEK-27919

MODEL	FORM	
	1 THRU 4	5 THRU 8
12GES21B(-)D		
VOLTS D.C.	125	250
RESISTANCE IN OHMS		
A COIL	2500	2500
B COIL	1200	1200
C COIL	2500	2500
E COIL	5000	5000
F COIL	5000	5000
G COIL	14,000	14,000
R1	1500	1500
R2	1500	1500
R3	3000	3000
R4	5000	5000
R5	500	500
R6	NONE	5600
R7	NONE	5600
R8	500	500
R9	NONE	12,000
R10	NONE	1750
R11	1500	1500
R12	4000	4000
R13	NONE	4000
R19	10,000	10,000
R20 A	7500	7500
R21 B	7500	7500
R22 A	7500	7500
R23	50,000	50,000
R24B	7500	7500
CAPACITANCE VALUE		
C2	0.25uf	0.25uf
C3	0.50uf	0.50uf
C4	0.50uf	0.50uf
C5	5.0uf	5.0uf
C6	180uf	180uf
C7 THRU C11	0.05uf	0.05uf

Figure 17B (0226A7239-3 Sheet 2) Internal Connection Diagram for GES21B Relay



P.C. CARD ASM. 0183B7987 GR-1

Figure 18 (0257A5061-0) Internal Connections for "A" Printed Circuit Card