



INSTRUCTIONS

TRANSFORMER DIFFERENTIAL RELAY WITH PERCENTAGE AND HARMONIC RESTRAINT

TYPE STD17C

INTRODUCTION

These instructions are a supplement to instruction book GEK-45307, which is included in this book. The combination of the two forms the instructions for the STD17C relay.

DESCRIPTION

The Type STD17C relay is similar to the STD16C except the former has four through-current restraint windings and is mounted in the L2 (large, double-ended) case.

SERVICING

CAUTION

Remove ALL power from the relay before removing or inserting any of the printed-circuit boards. Failure to observe this caution may result in damage to and/or misoperation of the relay.

Figure 1 shows the internal connections diagram for the STD17C relay.

Figure 2 shows the typical external wiring diagram for the STD17C relay.

Figure 3 shows the test circuit for the STD17C relay.

Figure 4 shows the outline and panel drilling for the STD17C L2 relay.

These instructions do not purport to cover all details or variations in equipment nor provide for every possible contingency to be met in connection with installation, operation or maintenance. Should further information be desired or should particular problems arise which are not covered sufficiently for the purchaser's purposes, the matter should be referred to the General Electric Company.

To the extent required the products described herein meet applicable ANSI, IEEE and NEMA standards; but no such assurance is given with respect to local codes and ordinances because they vary greatly.

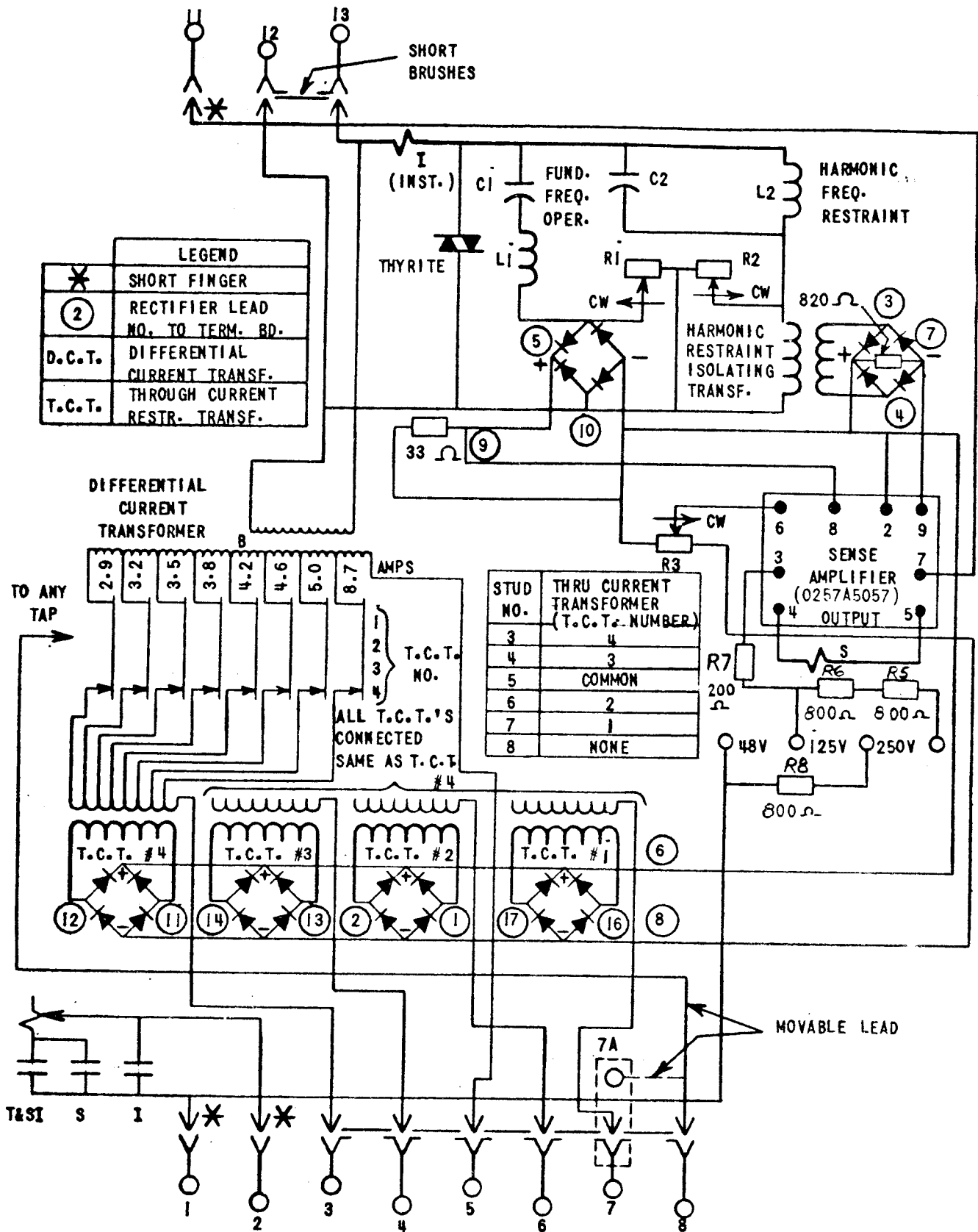

*Figure 1 (0257A5028 [2]) Internal Connections Diagram for the STD17C Relay (Front View)

* Revised since last issue

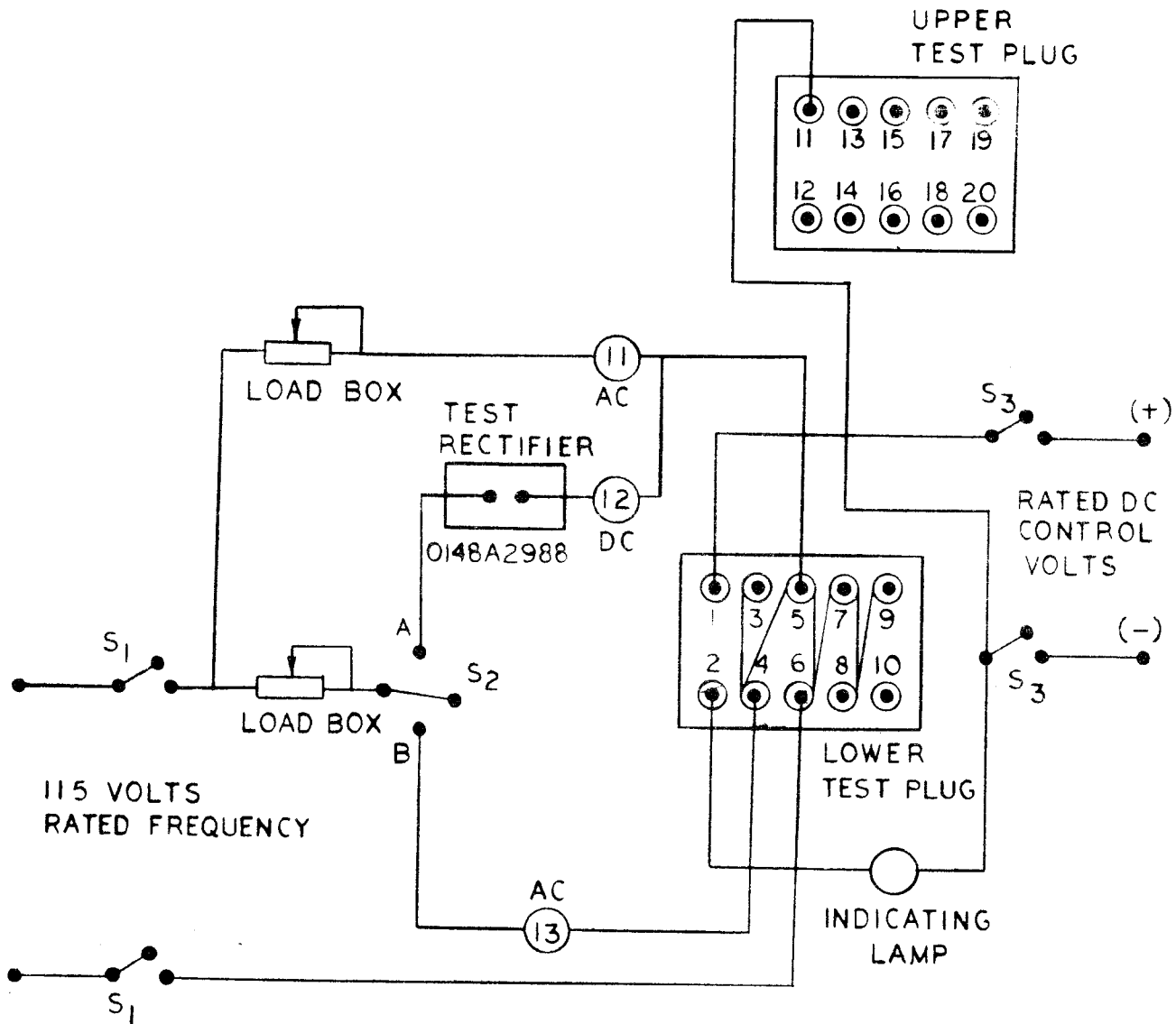

TEST CIRCUIT FOR STD17C OR STD18C RELAYS

Figure 3 (0257A5054 Sh.2) Test Connections Diagram for the STD17C Relay

***Meter and Control
Business Department***

(6/91) (1200)

General Electric Company
Protection and Control
205 Great Valley Parkway
Malvern, Pennsylvania 19355-0715

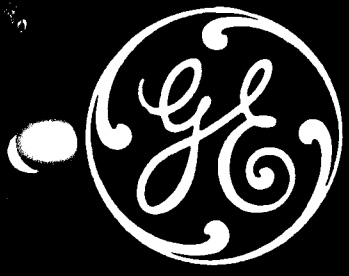

INSTRUCTIONS

GEK-45307

TRANSFORMER DIFFERENTIAL RELAYS WITH
PERCENTAGE AND HARMONIC RESTRAINT

TYPES STD15C AND STD16C

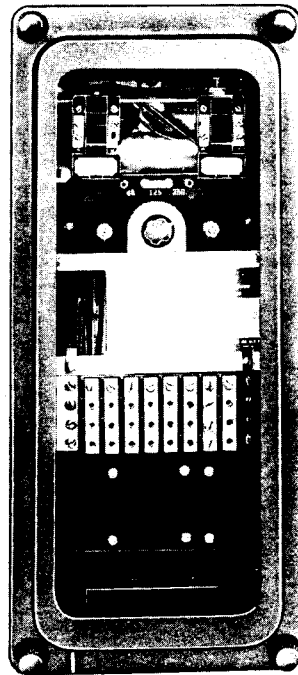

POWER SYSTEMS MANAGEMENT DEPARTMENT

GENERAL  ELECTRIC

PHILADELPHIA, PA.

CONTENTS

	<u>PAGE</u>
INTRODUCTION.....	3
DESCRIPTION.....	3
APPLICATION.....	3
CALCULATION OF SETTINGS.....	4
METHOD.....	4
CURRENT TRANSFORMER CONNECTIONS.....	4
DETERMINATION OF CT TURNS AND TYPE STD RELAY TAP SETTING..	4
CURRENT TRANSFORMER RATIO ERROR.....	5
PERCENT SLOPE SETTING.....	6
I DETERMINATION OF CT TURNS AND STD RELAY TAP SETTING.....	6
II PERCENT RATIO ERROR.....	7
IA REPEAT-CT TURNS AND RELAY TAP SETTING.....	7
IIA REPEAT - PERCENT RATIO ERROR.....	7
III PERCENT SLOPE SETTING.....	8
RATINGS.....	8
MODELS 12STD15B AND 12STD16B.....	8
AUXILIARY RELAY CONTROL CIRCUIT.....	8
CHARACTERISTICS.....	8
PICKUP AND OPERATING TIME.....	8
OVERCURRENT UNIT PICKUP.....	9
PERCENTAGE DIFFERENTIAL CHARACTERISTICS.....	9
HARMONIC RESTRAINT CHARACTERISTICS.....	9
BURDENS.....	10
CONSTRUCTION.....	10
CURRENT TRANSFORMERS.....	10
THROUGH CURRENT RESTRAINT CIRCUIT.....	11
DIFFERENTIAL - CURRENT CIRCUIT.....	11
OVERCURRENT UNIT.....	11
MAIN OPERATING UNIT.....	11
TARGET AND SEAL-IN UNIT.....	12
CASE.....	12
RECEIVING, HANDLING, AND STORAGE.....	12
ACCEPTANCE TESTS.....	12
VISUAL INSPECTION.....	12
MECHANICAL INSPECTION.....	12
ELECTRICAL TESTS.....	13
TEST FACILITIES.....	13
INSTALLATION PROCEDURE.....	13
TESTS.....	13
PICKUP.....	13
HARMONIC CURRENT RESTRAINT.....	14
THROUGH CURRENT RESTRAINT.....	14
INSTANTANEOUS OVERCURRENT UNIT.....	15
DROPOUT OF MAIN UNIT.....	15
LOCATION.....	15
MOUNTING.....	15
CONNECTIONS.....	15
ADJUSTMENTS.....	15
RATIO MATCHING ADJUSTMENT.....	15
UNBALANCE CURRENT MEASUREMENT.....	16
PERCENT SLOPE SETTING.....	16
OPERATION.....	16
TARGETS.....	16
DISABLING OF TYPE STD RELAY.....	16
MAINTENANCE.....	17
CONTACT CLEANING.....	17
PERIODIC TESTS.....	17
PICKUP.....	17
HARMONIC CURRENT RESTRAINT.....	17
THROUGH CURRENT RESTRAINT.....	17
RENEWAL PARTS.....	18

TRANSFORMER DIFFERENTIAL RELAYS
WITH PERCENTAGE AND HARMONIC RESTRAINT

STD15C AND STD16C

INTRODUCTION

Relays of the STD type are transformer differential relays provided with the features of percentage and harmonic restraint. A static decision unit controls a small telephone type relay which provides the contact output.

Percentage restraint permits accurate discrimination between internal and external faults at high current, while harmonic restraint enables the relay to distinguish, by the difference in waveform, between the differential current caused by an internal fault, and that of transformer magnetizing inrush.

DESCRIPTION

Each Type STD relay is a single phase unit. The Type STD15C relay is designed to be used for the protection of two-winding power transformers and has two through-current restraint circuits and one differential current circuit.

The Type STD16C relay is designed for use with three-winding power transformers and has three through current restraint circuits and one differential current circuit. It may also be used for four circuit transformer protection (see Figure 9) when only three circuits require through current restraint, while the fourth circuit, being the weakest, needs no through-circuit restraint.

APPLICATION

The current transformer ratios and relay taps should be selected to obtain the maximum sensitivity without risking thermal overload of the relay or current transformer, or the possibility of misoperation. Therefore, current transformer ratios in the various windings of the power transformer should be selected with the following points in mind:

1. The lower the relay tap and the lower the CT ratio selected, the higher will be the sensitivity. However, the lowest CT ratio and the lowest relay tap may not be compatible with some of the following restrictions. Where a choice is available of increasing either the CT ratio or the relay tap, it is desirable to increase the CT ratio in preference to the relay tap.

Since the relay burden is likely to be small compared to the lead burden, increasing the CT ratio tends to improve the relative performance of the CT's as a result of reducing the maximum secondary fault current and increasing the accuracy of the CT's.

2. The CT secondary current should not exceed the continuous thermal rating of the CT secondary winding.
3. The relay current corresponding to maximum KVA (on a forced cooled basis) should not exceed twice tap value, the thermal rating of the relay.
4. The CT ratios should be high enough that the secondary currents will not damage the relay under maximum internal fault conditions (refer to RATINGS).
5. The relay current corresponding to rated KVA of the power transformer (on self cooled basis) should not exceed the relay tap value selected (magnetizing inrush might operate the instantaneous overcurrent unit). If the transformer under consideration does not have a self-cooled rating, the transformer manufacturer should be consulted for the "equivalent self-cooled rating"; that is the rating of a self-cooled transformer that would have the same magnetizing inrush characteristics as the transformer being considered.

These instructions do not purport to cover all details or variations in equipment nor to provide for every possible contingency to be met in connection with installation, operation or maintenance. Should further information be desired or should particular problems arise which are not covered sufficiently for the purchaser's purposes, the matter should be referred to the General Electric Company.

6. The current transformer tap chosen must be able to supply the relay with 8 times rated relay tap current with an error of less than 20 percent of the total current. If the current transformers produce an error of greater than 20% at less than 8 times tap value, the harmonic content of the secondary current may be sufficient to cause false restraint on internal faults.
7. The CT ratios should be selected to provide balanced secondary current on external faults. Since it is rarely possible to match the secondary currents exactly by selection of current transformer ratios, ratio-matching taps are provided on the relay by means of which the currents may usually be matched within 5 percent. When the protected transformer is equipped with load ratio control it is obvious that a close match cannot be obtained at all points of the ratio-changing range. In this case the secondary currents are matched at the middle of the range and percentage-differential characteristic of the relay is relied upon to prevent relay operation on the unbalanced current which flows when the load-ratio control is at the ends of the range.
8. In some applications, the power transformer will be connected to the high voltage or low voltage system through two breakers (as shown in Fig. 9) as for example in a ring bus arrangement. In this case the CT ratios must be selected so that the secondary windings will not be thermally overloaded on load current flowing around the ring in addition to the transformer load current. It is recommended that CT's on each of the two low voltage (or high voltage) breakers be connected to a separate restraining winding to assure restraint on heavy through fault current flowing around the ring bus.

It is not desirable to protect two parallel transformer banks with one set of differential protection since the sensitivity of the protection will be reduced. In addition, if the banks can be switched separately, there is a possibility of false operation on magnetizing inrush to one transformer bank causing a "sympathetic inrush" into the bank already energized. In this case, the harmonics tend to flow between the banks with the possibility that there will be insufficient harmonics in the relay current to restrain the relay.

Typical elementary diagrams for the STD15C and STD16C is illustrated in Figures 7 and 8.

CALCULATION OF SETTINGS

METHOD

The calculations required for determining the proper relay and CT taps are outlined below. A sample calculation, for the transformer shown in Fig. 17, is shown later.

CURRENT TRANSFORMER CONNECTIONS

<u>Power Transformer Connections</u>	<u>Current Transformer Connections</u>
Delta-Wye	Wye-Delta
Wye-Delta	Delta-Wye
Delta-Delta	Wye-Wye
Wye-Wye	Delta-Delta
Delta-Zigzag	Delta-Delta
with zero degrees phase shift between primary and secondary	

DETERMINATION OF CT TURNS AND TYPE STD RELAY TAP SETTING

1. Determine maximum line currents (Max. I) on the basis that each power transformer winding may carry the maximum forced cooled rated KVA of the transformer.

$$\text{Max. } I_p = \frac{\text{Maximum Transformer KVA}}{\sqrt{3} \text{ (Line KV)}}$$

2. Determine the full load rated line currents (100% I_p) on the basis that each power transformer winding may carry the full self-cooled rated KVA of the transformer, or the "equivalent" self-ratings.

$$100\% I_p = \frac{100\% \text{ Transformer KVA}}{\sqrt{3} \text{ (Line KV)}}$$

Actually this calculation does not mean that all windings will necessarily carry these maximum load currents continuously. This is only a convenient way of calculating the currents in the other windings in proportion to their voltage ratings. This is the requirement for selecting the relay tap setting so that the relay will not operate for any external fault.

3. Select CT ratios so that the secondary current corresponding to maximum I_p does not exceed the CT secondary thermal rating (5 amperes). In the case where a transformer is connected to a ring bus, for example, the CT ratio should be selected so that the CT thermal rating will not be exceeded by the maximum load current in either breaker. Also select CT ratios so that the relay currents can be properly matched by means of the relay taps. (Highest current not more than 3 times lowest current).

For Wye connected CT's

$$\text{Tap Current} = \frac{100\% I_p}{N}$$

For Delta connected CT's

$$\text{Tap Current} = \frac{100\% I_p \sqrt{3}}{N}$$

Where N is the number of CT secondary turns.

4. Check the matching of relay currents to relay taps to keep the mismatch error as low as possible.

Calculate the percent of mismatch as follows: on two winding transformers, determine the ratio of the two relay currents and the tap values selected. The differences between these ratios, divided by the smaller ratio, is the percent of mismatched. The mismatch normally should not exceed 5%.

For three-winding transformers, the percent of mismatch error should be checked for all combinations of currents or taps.

If taps cannot be selected to keep this percentage error within allowable limits, it will be necessary to choose a different CT ratio on one or more lines to obtain a better match between relay currents and relay taps.

5. Check to see that the sum of the relay currents that will be applied to the relay for a fault at the terminals of the power transformer is less than 220 amperes RMS for 1 second. If the period during which a fault current flows in the relay can be definitely limited to a shorter time, a higher current can be accommodated in accordance with the relation:

$$(\text{Amperes})^2 \times \text{seconds} = 48,400$$

Also check that the sum of the multiples of tap current on an internal or external fault do not exceed 150.

CURRENT TRANSFORMER RATIO ERROR

The CT ratio error must be less than 20 percent at 8 times relay rated tap current. This is based on the instantaneous unit being set at its normal setting which is 8 times tap rating. If the instantaneous unit pickup is raised above this value, the 20 percent figure must be reduced as described under the heading CHARACTERISTICS.

The calculations listed below are for the worst fault condition, as far as CT performance is concerned which is an internal ground fault between the CT and the transformer winding with none of the fault current supplied through the neutral of the protected transformer.

1. Determine the burden on each CT, using the following expressions:

a. For Wye connected CT's

$$Z = B + \frac{Ne + 2f}{1000} + 2R \text{ Ohms} \quad (\text{EQ. 1})$$

b. For delta connected CT's

$$Z = 2B + \frac{Ne + 2f}{1000} + 2R \text{ Ohms} \quad (\text{EQ. 2})$$

Where B = STD relay total burden (see Table I)

N = number of turns in bushing CT

e = bushing CT resistance per turn, milliohms (at maximum expected temperature)

f = bushing CT resistance per lead, milliohms (at maximum expected temperature)

R = one-way control cable lead resistance (at maximum expected temperature)

2. Determine CT secondary current for 8 times tap setting.

$$I_S = 8 \times \text{STD relay tap rating}$$

(NOTE: For the location of fault assumed, all the fault current is supplied by one CT, so that CT current and relay current are the same, regardless of whether the CT's are connected in wye or delta.)

3. Determine secondary CT voltage required at 8 times tap setting.

$$E_{\text{sec}} = I_S Z$$

4. From excitation curve of particular tap of current transformer being used, determine excitation current, I_E , corresponding to this secondary voltage, E_{sec} .

5. Determine the percent error in each CT by the expression:

$$\% \text{ error} = \frac{I_E}{I_S} \times 100$$

This should not exceed 20 percent on any set of CT's. If it does, it will be necessary to choose a higher tap on that set of CT's, and repeat the calculations on selection of relay taps, mismatch error, and percent ratio error.

PERCENT SLOPE SETTING

The proper percent slope required is determined by the sum of:

- a. The maximum range of manual taps and the load-ratio-control, or automatic tap changing means, in percent.
- b. The maximum percent of mismatch of the relay taps.

The percentage slope tap selected should be greater than the ratio of maximum total error current to smaller of the through currents. In general, if the total error current does not exceed 20 percent, the 25 percent tap is used. If it exceeds 20 percent, but not 35 percent, the 40 percent tap is used.

If the movable lead is used (see Figure 2 for example) the percent slope tap should be chosen about twice as high since the movable lead provides no restraint.

EXAMPLE REFER TO FIG. 17

I DETERMINATION OF C.T. TURNS AND STD RELAY TAP SETTINGS

	A	B	C
1. Transformer and Line			
2. Max. $I_p = 3750/\sqrt{3}$ (line KV)	19.7	49.5	157
3. 100% $I_p = 3000/\sqrt{3}$ (line KV)	15.7	39.6	125
4. Assume CT turns (N)	20	20	60
5. Max. I secondary (less than 5a)	0.98	2.47	2.62
6. 100% I secondary	0.79	1.98	2.08
7. CT connections	Delta	Wye	Delta
8. Relay Current for 100% I Sec.	1.37	1.98	3.60

Select a relay tap for one of the line currents and calculate what the currents in other lines would be if they were increased in the same ratio. If any current is greater than root three times any other, the 8.7 tap should be chosen for it and new ideal relay taps calculated for the other lines.

9. Ideal Relay Taps (Set C = 8.7)	3.31	4.78	8.7
10. Try Relay Taps	3.2	4.6	8.7
11. Check Mismatch Error			

Ratio of Taps on Lines B-A $\frac{4.6}{3.2} = 1.43$ Ratio of Sec. Lines Currents $\frac{1.98}{1.37} = 1.44$

Mismatch $\frac{1.44 - 1.43}{1.43} = 0.7\%$

Ratio of Taps on Lines C-B $\frac{8.7}{4.6} = 1.89$ Ratio of Sec. Line Currents $\frac{3.60}{1.98} = 1.82$

Mismatch $\frac{1.89 - 1.82}{1.82} = 3.8\%$

Ratio of Taps on Lines C-A $\frac{8.7}{3.2} = 2.72$ Ratio of Sec. Line Currents $\frac{3.60}{1.37} = 2.63$

Mismatch $\frac{2.72 - 2.63}{2.63} = 3.4\%$

(All are less than 5%; therefore, mismatch error is not excessive)

12. Check that the sum of the maximum relay currents is less than 220 amps for one second, and therefore, short-time rating of relay is not exceeded.

II PERCENT RATIO ERROR

ASSUME (all measured at their maximum expected temperatures)

One-way CONTROL CABLE RESISTANCE (R) = .284 ohms

Bushing A CT resistance per turn (e) = 4 milliohms

" B " " " (e) = 2.5 "

" C " " " (e) = 2.3 "

Bushing A CT resistance per lead (f) = 75 "

" B " " " (f) = 52.5 "

" C " " " (f) = 18.6 "

1. BURDENS ON CT's

USING EQ. 1 OR EQ. 2 from page 5.

a. Line A, $Z = 2 (0.156) + \frac{(20 \times 4) + (2.0 \times 75)}{1000} + 2 (.284)$

$= 0.312 + 0.205 + 0.568 = 1.085$

b. Line B, $Z = 0.096 + \frac{(20 \times 2.5) + (2.0 \times 52.5)}{1000} + 0.568$

$+ 0.096 + 0.138 + 0.568 = 0.80$

c. Line C, $Z = 2 (0.048) + \frac{(60 \times 2.3) + (2 \times 18.6)}{1000} + 0.568 = 0.096 + 0.180 + 0.568 = 0.833$

	<u>A</u>	<u>B</u>	<u>C</u>
2. Impedance, ohms	1.085	0.8	0.833
3. 8 Times tap, amperes	25.6	36.8	69.6
4. E_s CT voltage required (IZ)	27.8	29.4	58.0
5. I_E , required, from excitation curve	1.00	50	0.5
6. % Ratio Error	3.4%	136%	0.8%

Exciting current on line B is too high; should try higher tap on CT to improve CT performance.

IA REPEAT - CT TURNS AND RELAY TAP SETTING

1. 100% I_p	15.7	39.6	125
2. Try CT turns (necessary to change C also for proper matching)	20	40	80
3. 100% I secondary	0.79	0.99	1.56
4. Relay Current	1.37	0.99	2.70
5. Ideal Relay Taps (SET C = 8.7)	4.40	3.19	8.7
6. Use Taps	4.6	3.2	8.7
7. Mismatch error is less than 5%			

TABLE I

Total Burden for 60 Cycle Relays

STD TAPS AMPS	8 X TAP AMPS	BURDEN OHMS (B)	MIN. P.U. AMPS
2.9	23.2	0.180	0.87
3.2	25.6	0.156	0.96
3.5	28.0	0.140	1.05
3.8	30.4	0.120	1.14
4.2	33.6	0.112	1.26
4.6	36.8	0.096	1.38
5.0	40.0	0.088	1.50
8.7	69.6	0.048	2.61

IIA REPEAT - PERCENT RATIO ERROR

1. Burden on CT's

Line A, $Z = 0.192 + 0.205 + 0.568 = 0.965$

Line B, $Z = 0.156 + 0.188 + 0.568 = 0.912$

Line Cm $Z = 0.096 + 0.226 + 0.568 = 0.890$

2. Impedance, Ohms	.965	.912	.890
3. 8 Times Tap, Amperes	36.8	25.6	69.6
4. E_{sec} , CT voltage required (IZ)	35.6	23.4	61.9
5. I_E required, from excitation curve	1.1	0.25	0.17
6. % of Ratio Error	3.1%	1.0%	0.3%

Percent Error is less than 20%, so CT taps and Relay taps are satisfactory.

III PERCENT SLOPE SETTING

1. Assume load ratio control maximum range	10.0%
2. Relay Tap mismatch, from IA above (Lines A-B)	4.6%
Use 25% tap.	14.6%

RATINGS

MODELS 12STD15C AND 12STD16C

Continuous rating - The through current transformer and differential current transformer will stand twice tap value for any combination of taps or they will stand twice tap value if all but one of the restraint windings carry zero current and the full restraint current, equal to twice tap value, flows through the differential current transformer.

Short Time Rating (thermal) - 220 amperes for 1 second measured in the primary of any transformer of the type STD relay. Higher currents may be applied for shorter lengths of time in accordance with the following equation:

$$I^2t = 48,400$$

where:

I = current amperes

t = time in seconds

Short Time (electrical) - For both the STD15C and STD16C the sum of the multiples of tap current fed to the relay from the several sets of current transformers should not exceed 150. These multiples should be calculated on the basis of RMS symmetrical fault current. This limitation is a result of the voltage rating of the rectifiers in the through current restraint circuit. Note that in Fig. 9 external fault current can flow through circuit breakers 52-1 and 52-2 without being limited by the transformer impedance.

TABLE II

	TARGET AND SEAL-IN UNIT		
	2.0 Amp Tap	0.6 Amp Tap	0.2 Amp Tap
D-C Resistance	0.13 Ohms	0.6 Ohms	7 Ohms
Carry Continuously	0.5 Amps	1.5 Amps	0.25 Amps
Carry 30 Amps for	4 Secs.	0.5 Secs.	-----
Carry 10 Amps for	30 Secs.	4 Secs.	0.2 Secs.

AUXILIARY RELAY CONTROL CIRCUIT

The STD15C and STD16C relays are available for use with 48, 125, and 250 d-c control voltage. A plate with small links located on the front of the relay enables the selection of one of these voltages.

The STD relay is provided with two open contacts connected to a common output circuit. The current closing rating of the contact is 30 amps for voltages not exceeding 250 volts. If more than one circuit breaker is to be tripped, or if the tripping current exceeds 30 amperes, an auxiliary relay must be used with the STD relay. After the breaker trips, it is necessary that the tripping circuit of these relays be de-energized by an auxiliary switch on the circuit breaker or by other automatic provisions. A manual reset relay is recommended and normally used.

CHARACTERISTICS

PICKUP AND OPERATING TIME

The operating characteristic is shown in Fig. 1. The curve for various percentage slopes shows the percent slope versus the through current flowing in the transformer. The percentage slope is a figure given to a particular slope tap setting and indicates an approximate slope characteristic. Pickup at zero restraint is approximately 30 percent of tap value (see Table III). The dropout time when the operating current is reduced from any value above pickup to zero is less than 25 milliseconds.

Curves of the operating time of the main unit and of the instantaneous unit are shown in Fig. 2, plotted against differential current. The main unit operating time includes auxiliary unit operating time.

OVERCURRENT UNIT PICKUP

The overcurrent unit is adjusted to pickup when the differential current transformer ampere-turns are 8 times the ampere turns produced by rated tap current flowing in that tap. For example:

When only one CT supplies current, and the tap plug for the CT is in the 5 ampere tap, 40 amperes are required for pickup. This pickup value is based on the A-C component of current transformer output only, since the differential current transformer in the relay produces only a half cycle of any d-c (offset) component present.

If ratio matching taps are chosen so that rated CT current is not greater than the tap rating on a self cooled basis, the overcurrent unit will not pickup on magnetizing inrush. If CT currents are greater than tap rating, there is danger that the unit may pickup, especially on small transformer banks. If this happens, it is recommended that the CT ratio or relay tap setting be increased rather than increasing the pickup of the overcurrent unit. If the overcurrent setting must be raised, the requirements on CT error will be more stringent in accordance with the following equation:

$$E = 20 - (2.5) (P-8)$$

where:

E = CT error current in percent at pickup of the overcurrent unit.

P = Pickup of overcurrent unit in multiples of tap setting.

PERCENTAGE DIFFERENTIAL CHARACTERISTICS

The percentage differential characteristics are provided by through current restraint circuits. In addition to the operating circuit, which is energized by the differential current of the line current transformers, the relay is equipped with a restraining circuit that is indirectly energized by the transformer secondary currents. For the relay to operate, the current transformer secondary currents must be unbalanced by a certain minimum percentage determined by the relay slope setting (as shown in Fig. 1). This characteristic is necessary to prevent false operation on through fault currents. High currents saturate the cores of the current transformers and cause their ratios to change, with the result that the secondary currents become unbalanced. Percentage restraint is also required to prevent operation by the unbalanced currents caused by imperfect matching of the secondary currents as previously described under RATIO MATCHING TAPS.

HARMONIC RESTRAINT CHARACTERISTICS

At the time a power transformer is energized, current is supplied to the primary which establishes the required flux in the core. This current is called magnetizing inrush, and flows only through the current transformers in the primary winding. This causes an unbalance current to flow in the differential relay which would cause false operation if means were not provided to prevent it.

Power system fault currents are of a nearly pure sine waveform plus a d-c transient component. The sine waveform results from sinusoidal voltage generation and nearly constant circuit impedance. The d-c component depends on the time in the voltage cycle at which fault occurs and upon circuit impedance magnitude and angle.

Transformer magnetizing inrush currents vary according to the extremely variable exciting impedance resulting from core saturation. They are often of high magnitude, occasionally having an RMS value with 100 percent offset approaching 16 times full load current for worst conditions of power transformer residual flux and point of circuit closure on the voltage wave. They have a very distorted waveform made up on sharply peaked half-cycle loops of current on one side of the zero axis, and practically no current during the opposite half cycles. The two current waves are illustrated in Fig. 3.

Any current of distorted, nonsinusoidal waveform may be considered as being composed of a direct-current component plus a number of sine-wave components of different frequencies; one of the fundamental system frequency and the others, called "harmonics" having frequencies which are 2, 3, 4, 5, etc., times the fundamental frequency. The relative magnitudes and phase positions of the harmonics with reference to the fundamental determine the wave-form. When analyzed in this manner, the typical fault current wave is found to contain only a very small percentage of harmonics while the typical magnetizing inrush current wave contains a considerable amount.

The high percentage of harmonic currents in the magnetizing inrush current wave afford an excellent means of distinguishing it electrically from the fault current wave. In the Type STD relays, the harmonic components are separated from the fundamental component by suitable electric filters. The harmonic current components are passed through the restraining circuit of the relay, while the fundamental component is passed through the operating circuit. The direct current component present in both the magnetizing inrush and offset fault current waves is largely blocked by the auxiliary differential current transformer inside the relay and produces only a slight momentary restraining effect. Relay operation occurs on differential current waves in which the ratio of harmonics to fundamental is lower than a given predetermined value for which the relay is set (e.g. an internal fault current wave) and is restrained on differential current waves in which the ratio exceeds this value (e.g. magnetizing inrush current wave).

BURDENS

Burdens are shown in Table III. Burdens and minimum pickup values are substantially independent of the percent slope settings and are all approximately 100 percent power factor. Figures given are burdens imposed on each current transformer at 5.0 amperes.

DC control circuit burden is 40 milliamperes at rated DC voltage.

CONSTRUCTION

Figure 4 shows the internal arrangement of the components of the STD15C relay. Refer also to the internal connection diagrams, Figs. 10 and 11, which will identify the parts more completely.

CURRENT TRANSFORMERS

In the Type STD15C relay, the through current transformer has two primary winding, one for each line current transformer circuit. Winding No. 1 terminates at stud 6 and winding No. 2 terminates at stud 4.

In the Type STD16C relay, there are three separate through current transformers, each with only one primary winding and each terminating at a separate stud, windings No. 1, No. 2 and No. 3 corresponding to studs 6, 4, and 3 in that order.

In both relays there is a differential current transformer with one primary lead brought out to stud 5.

The primary circuit of each of these transformers is completed through a special tap block arrangement. Two or three horizontal rows of tap positions are provided (depending on whether the relay is a Type STD15C or STD16C), one row for each through current transformer winding. A tap on the differential current transformer is connected to a corresponding tap of the through current restraint windings by inserting tap plugs in the tap blocks.

When the STD16C relay is used on four-circuit applications as shown in Fig. 9, the fourth circuit CT is connected to stud 7, and the jumper normally connected between terminals 6 and 7 at the rear of the relay cradle should be disconnected at the terminal 6 end and reconnected to the upper row in the tap block (above the row marked winding 1) which connects it directly to the differential current transformer in the STD relay. The terminal on the movable lead should be placed under the tap screw which gives the best current match for the current in the movable lead.

The taps permit matching of unequal line current transformer secondary currents. The tap connections are so arranged that in matching the secondary currents, when a tap plug is moved from one position to another in a horizontal row, corresponding taps on both the differential current transformer winding and one of the through current transformer windings are simultaneously selected so that the percent through current restraint remains constant.

TABLE III

RELAY	TAP SETTING AMPS	ZERO RESTRAINT PICKUP AMPS	OPERATING CIRCUIT *		RESTRAINT CIRCUIT	
			60 CYCLE RELAYS		60 CYCLE RELAYS	
			BURDEN VA	IMPEDANCE OHMS	BURDEN VA	IMPEDANCE OHMS
12STD15C 12STD16C	2.9	0.87	3.2	0.128	1.3	0.052
	3.2	0.96	2.7	0.108	1.2	0.048
	3.5	1.05	2.4	0.096	1.1	0.044
	3.8	1.14	2.0	0.080	1.0	0.040
	4.2	1.26	1.9	0.076	0.9	0.036
	4.6	1.38	1.6	0.064	0.8	0.032
	5.0	1.50	1.5	0.060	0.7	0.028
	8.7	2.61	0.7	0.028	0.5	0.020

* Burden of operating coil is zero under normal conditions

Burden of 50 cycle relay is the same or slightly lower

It should be recognized that pickup current flows not only through differential current transformer but also through one of the primary windings of the through current transformer producing some restraint. However, compared to the operating energy, this quantity of restraint is so small that it may be assumed to be zero.

THROUGH CURRENT RESTRAINT CIRCUIT

A full wave bridge rectifier receives the output of the secondary of each through current restraint transformer. In the STD16C relay, the d-c output of all three units are connected in parallel. The total output is directed to the percent slope rheostat (R_3) located on the front of the relay. By means of adjusting the rheostat, the percent slope may be varied from 15 to 40 percent. The output is put through an isolating transformer, rectified and directed to the sensitive solid state amplifier which controls the telephone type relay.

DIFFERENTIAL - CURRENT CIRCUIT

The differential current transformer secondary supplies the instantaneous unit directly; the operating signal to the solid state amplifier through a series tuned circuit; and the harmonic restraint isolating transformer through a parallel resonant filter. The operating and restraint currents are each rectified by a full wave bridge prior to being supplied to the sensitive amplifier.

The series resonant circuit is made up of a 5 microfarad * Pyranol capacitor (C1) and a reactor (L1) which are tuned to pass currents of the fundamental system frequency and to offer high impedance to currents of other frequencies. Resistor R1 is connected in parallel on the a-c side of the operate rectifier and can be adjusted to give the desired amount of operate current. The output of the rectifier is applied to the operating circuit of the sense amplifier.

The parallel resonant trap is made of a 15 microfarad * Pyranol capacitor (C2) and a reactor (L2), which are tuned to block fundamental frequency currents while allowing currents of harmonic frequencies to pass with relatively little impedance. Resistor R2 is connected in parallel on the a-c side of the harmonic restraint rectifier, and can be adjusted to give the desired amount of harmonic restraint. The output of the rectifier is paralleled with the through current restraint currents and applied to the restraint circuit of the sense amplifier.

It will be evident that if the differential current applied to the relay is sinusoidal and of system frequency, it will flow mostly in the operating circuit and hence cause the relay to yield an output. If, however, the differential circuit contains more than a certain percentage of harmonics, the relay will be restrained from operating by the harmonic currents flowing in the restraint circuit.

A *Thyrite resistor connected across the secondary of the differential current transformer limits any momentary high voltage peaks which may occur, thus protecting the rectifiers and capacitors from damage without materially affecting the characteristics of the relay.

OVERCURRENT UNIT

The instantaneous unit is a hinged armature relay with a self contained target indicator. On extremely heavy internal fault currents, this unit will pick up and complete the trip circuit. The instantaneous unit target will be exposed, to indicate that tripping was through the instantaneous unit.

Because of saturation of the CT's and relay transformers at high fault currents, it is impossible that less operating currents will be provided from the differential-current transformer than the percentage slope tap would imply, and more harmonic restraint will be provided than the actual harmonic content of the fault current would supply. As a result, under conditions of a high internal fault current, the main unit may be falsely restrained. Tripping is assured, however, by the overcurrent unit operation. Pickup is set above the level of differential current produced by maximum magnetizing inrush current. Figure 2 shows the relative levels of pickup and speed of operation of the main unit and the overcurrent unit.

* Registered Trade-Mark of the General Electric Company

MAIN OPERATING UNIT

The primary functioning unit of the STD relay is a solid state amplifier whose output controls a simple telephone relay. The sense amplifier is shown in Fig. 10 and 11 as a large rectangle. The amplifier consists of many electronic components mounted on a printed circuit card in the top half of the relay.

This printed circuit card is installed in an eight-prong printed card design base. This component is adjusted prior to leaving the factory and should require no further attention. A schematic of this card is shown in Fig. 18. The telephone-type relay is mounted vertically in the mid-section of the relay. It too has been carefully adjusted at the factory and should require no further attention. If this small relay has been disturbed, refer to the section under adjustment.

TARGET AND SEAL-IN UNIT

There is a target and seal-in unit mounted on the top left of the relay. This unit has its coil in series and its contacts in parallel with the main contacts of the telephone-type relay. When the telephone-type relay contacts close, the seal-in unit operates; raising its target into vision and sealing around the telephone type contacts. The target of this unit will remain exposed until released by pushing a button beneath the lower left corner of the cover of the relay case.

CASE

The case is suitable for surface or semi-flush panel mounting, and an assortment of hardware is provided for either method. The cover attaches to the case, and carries the target reset mechanism for the trip indicator and instantaneous unit. Each cover screw has provision for a sealing wire.

The case has studs or screw connections at the bottom for the external connections. The electrical connections between the relay unit and the case studs are made through spring backed contact finger mounted in stationary molded inner and outer blocks between which rests a removable connecting plug which completes the circuit. The outer block, attached to the case, holds the studs for the external connection, and the inner block has terminals for the internal connections.

The relay mechanism is mounted in a steel framework called the cradle and is a complete unit with all leads terminating at the inner block. This cradle is held firmly in the case with a latch at the top and bottom and by a guide pin at the back of the case. The case and cradle are so constructed that the relay cannot be inserted in the case upside down. The connecting plug, besides making the electrical connection between the blocks of the cradle and case, also locks the latch in place. The cover, which is fastened to the case by thumbscrews, holds the connecting plug in place.

To draw out the relay unit, the cover is removed and the plug is drawn out. Shorting bars are provided in the case to short the current transformer circuits (see Fig. 6). The latches are then released and the relay unit can be easily drawn out.

A separate testing plug can be inserted in place of the connecting plug to rest the relay in place on the panel either from its own source of current, or from other sources. Or, the relay unit can be drawn out and replaced by another which has been tested in the laboratory.

RECEIVING, HANDLING OR STORAGE

These relays, when not included as a part of a control panel will be shipped in cartons designed to protect them against damage. Immediately upon receipt of a relay, examine it for any damage sustained in transit. If injury or damage resulting from rough handling is evident, file a damage claim at once with the transportation company and promptly notify the nearest General Electric Apparatus Sales Office.

Reasonable care should be exercised in unpacking the relay in order that none of the parts are injured or the adjustments disturbed.

If the relays are not to be installed immediately, they should be stored in their original cartons in a place that is free from moisture, dust and metallic chips. Foreign matter collected on the outside of the case may find its way inside when the cover is removed and cause trouble in the operation of the relay.

ACCEPTANCE TESTS

Immediately upon receipt of the relay an inspection and acceptance test should be made to insure that the relay has not been damaged in shipment and that the relay calibrations are unchanged.

VISUAL INSPECTION

Check the nameplate stamping to insure that the model number, rating and calibration range of the relay received agree with the requisition.

Remove the relay from its case and check by visual inspection that there are no broken or cracked molded parts or other signs of physical damage and that all screws are tight.

MECHANICAL INSPECTION

Check the operation of the telephone type relay and instantaneous overcurrent unit manually to see that they operate smoothly without noticeable friction or binds. Check the contact gap and wipe of these units which should agree with values given under the section on SERVICING.

ELECTRICAL TESTS

It is recommended that the following electrical tests be made immediately upon receipt of the relay.

1. Minimum pickup of main operating unit.
2. Minimum pickup of the instantaneous overcurrent unit.
3. A single check point on the harmonic restraint characteristic.
4. A single check point on the slope characteristic curve for approximate slope expected to be used.

TEST FACILITIES

In order to facilitate tests, the following test equipment is recommended:

1. Two load boxes for regulating the test currents.
2. Three ammeters (2 A.C. and 1 D.C.) for measuring the test currents.
3. A test rectifier for checking the relays response to the second harmonic.
4. One indicating lamp.
5. Two single pole double throw switch selector.
6. A double pole single throw line switch.

Check the pickup of the main unit connections shown in Fig. 12. During this test, the selector switches (S2 and S4) are open and current passes through the differential circuit only. For example, with a relay set with a 25 percent slope and at the 2.9 ampere ratio matching taps, the main unit should pick up at 30 percent of tap rating plus or minus 10 percent, or the pickup should be between 0.78 and 0.96 amperes. To check that the main unit has picked up a source of DC power at rated voltage should be connected as shown in Fig. 12, and the indicating lamp will provide a signal showing that the main unit has operated.

For an additional pickup test, the pickup should be 1.5 amperes with current flowing in terminals 5 and 6 and the tap plugs in the 5 ampere tap, and the 25 percent slope tap position. If the pickup is between 1.35 and 1.65 amperes, no adjustment should be made. The pickup of the relay has wider permissible variations than most protective relays, but due to the relay design and application, the relay accuracy is entirely adequate under all conditions even during transformer magnetizing inrush or severe fault conditions.

With the selector switch, S2 in the A position, check the harmonic current restraint as described under the section on INSTALLATION PROCEDURE.

The instantaneous overcurrent unit should be checked by passing a high current through the 5-6 terminals. The pickup should be about 8 times tap rating.

Check through current restraint as described under section on INSTALLATION PROCEDURE.

INSTALLATION PROCEDURETESTS

Before placing the relays in service, check the relay calibration to be used in its final location to insure that it is correct. The following test procedure is outlined for this purpose.

CAUTION: THE RELAY CALIBRATION IS ACCOMPLISHED BY ADJUSTING RESISTORS R_1 , R_2 , AND R_3 . CHANGES MADE IN ANY ONE OF THESE RESISTORS WILL AFFECT THE OTHER TWO SETTINGS. IN THE EVENT ONE SETTING IS CHANGED, THE PICKUP, HARMONIC RESTRAINT, AND THROUGH CURRENT RESTRAINT ADJUSTMENT PROCEDURES SHOULD BE REPEATED UNTIL NO FURTHER DEVIATION FROM PROPER CALIBRATION IS NOTED. BEST RESULTS CAN BE OBTAINED IF THE THROUGH CURRENT RESTRAINT ADJUSTMENT IS MADE ONLY AFTER THE OTHER TWO SETTINGS ARE CORRECT.

PICKUP

The test circuit for pickup is shown in Fig. 14 with S2 open. Pickup should be 1.5 amperes with current flowing in terminals 5 and 6, and the tap plugs in the 5 ampere position, and 25 percent slope tap setting. The pickup operation should be repeated several times until two successive readings agree within 0.01 ampere and the total pickup current being interrupted between successive checks. If pickup is found to be from 1.35 - 1.65, the setting should not be disturbed.

With d-c control voltage applied to the proper terminals of the relay, the pickup of the telephone type relay can be used as an indication of operation of the amplifier. This voltage may be applied as shown in Fig. 14 and the indicating lamp will verify that the amplifier has produced an output signal.

Before R_1 is adjusted for pickup, put a D.C. voltmeter (1 volt scale) on pin 2 (-) and pin 8 (+) of the sense amplified card. The pins are counted from right to left when viewed from the card socket wiring connections. Apply pickup current and adjust R_1 for a voltage input to the sense amplifier card of 0.430 to 0.470 volts. If the pickup is not in limits with this setting then adjust P_1 on the sense amplifier card to obtain the proper pickup value.

HARMONIC CURRENT RESTRAINT

The harmonic restraint is adjusted by means of a Test Rectifier used in conjunction with suitable ammeters and load boxes. The test circuit is as shown in Fig. 14 with S2 closed to position A. Tests should be made on the 5.0 ampere and 25% slope taps.

The analysis of a single phase half wave rectified current shows the presence of fixed percentages of d-c, fundamental, and second harmonic components as well as negligible percentages of all higher even harmonics. This closely approximates a typical transformer inrush current as seen as the relay terminals in as much as its principal components are d-c, fundamental, and second harmonic. Although the percent second harmonic is fixed, the overall percentage may be varied by providing a path for a controlled amount of by-passed current of fundamental frequency. The by-passed current is added in phase with fundamental component of the half wave rectified current and thus provides a means of varying the ratio of second harmonic current to fundamental current.

The following expression shows the relationship between the percent second harmonic, the d-c component, and the by-pass current.

$$\% \text{ Second Harmonic} = \frac{0.212 I_{d-c}}{0.45I_1 + 0.5 I_{d-c}} \times 100$$

Figure 15 is derived from the above expression. It shows the percent second harmonic corresponding to various values of by-pass current (I_1) for a constant d-c set at 4.0 amperes.

The relay is calibrated with a composite RMS current of two time tap value. When properly set the relay will restraint with greater than twenty percent second harmonic but will operate with second harmonic equal to twenty percent or lower. With the d-c ammeter (I_2) set at 4.0 amperes, the auxiliary relay should just begin to close its contacts with gradually increasing by-pass current (I_1) at a value of 4.5-5.5 amperes. This corresponds to 19-21 percent second harmonic (see Fig. 15) providing a two percent tolerance at the set point to compensate for normal fluctuations in pickup. It should be noted that the current magnitude in the rectifier branch (I_2) is slightly influenced by the application of by-pass current (I_1) and should be checked to insure it is maintained at its proper value.

If harmonic restraint is found to be out of adjustment, it may be corrected by adjusting Rheostat R₂.

THROUGH CURRENT RESTRAINT

The through current restraint, which gives the relay the percentage differential or percent slope characteristics are shown in Fig. 1. It may be checked and adjusted using the circuit illustrated in Fig. 14 with S₂ closed to position B. Ammeter I₁ reads the differential current and I₃ reads the smaller of the two through currents. In testing STD16C relays, the setting should be checked with the switch S₄ first in one position and then the other, thus checking all the restraint coils. With the current tap plugs in 5.0 ampere position and the percent slope tap plug in the 40 percent position, the relay should just pick up for values of the I₁ and I₃ currents indicated in Table IV. Repeat with the percent slope tap plug in the 25 percent and 15 percent position. If any one of these set points is found to be the other than as prescribed, the adjustment may be made by adjusting R₃. It should be noted that the current magnitude in the through current branch (I₃) is slightly influenced by the application of differential current (I₁) and should be checked to insure that it is maintained as its proper value.

Any change in R₃ to give the desired slope will have small effect upon minimum pickup and harmonic restraint. However, after the slope setting has once been set, any adjustment of minimum pickup will change the slope characteristics. The slope set points must then be rechecked to insure that they are in accordance with Table III.

NOTE: These currents should be permitted to flow for only a few seconds at a time with cooling periods between tests; otherwise, the coils will be overheated.

NOTE: The percent slope tolerance is 10 percent of nominal, all in the plus direction. This is to insure that the slope characteristic never falls below tap value.

TABLE IV

PERCENT SLOPE TAP	POSITION ON RHEOSTAT	AMPERES		TRUE SLOPE (I ₁ / I ₃ x 100)
		I ₃	I ₁	
40	Right	30	12.0-13.2	40.0-44.0
25	Middle	30	7.5- 8.3	25.0-27.5
15	Left	30	4.5- 5.0	15.0-16.5

INSTANTANEOUS OVERCURRENT UNIT

This unit is located at the upper right-hand side of the relay. Its setting may be checked by passing a high current of rated frequency through terminals 5 and 6. The unit should pick up at 8 times the tap rating as described under CHARACTERISTICS. If the setting is incorrect, it may be adjusted by loosening the lock-nut at the top of the unit and turning the cap screw until the proper pickup is obtained. In making this adjustment, the current should not be allowed to flow for more than approximately one second at a time.

DROPOUT OF MAIN UNIT

After the other tests are complete, check the dropout of the main unit as described under ACCEPTANCE TEST section.

LOCATION

The location should be clean and dry, free from dust and excessive vibration, and well lighted to facilitate inspection and testing.

MOUNTING

The relay should be mounted on a vertical surface. The outline and panel drilling dimensions are shown in Figure 5.

CONNECTIONS

Internal connection diagrams are shown in Figs. 10 and 11. Typical wiring diagrams are given in Figs. 7, 8 and 9 for differential applications.

Of course, any through current transformer winding may be used for any power transformer winding provided the taps are properly chosen.

When the relay is mounted on an insulating panel, one of the steel supporting studs should be permanently grounded by a conductor not less than No. 12 AWG gage copper wire or its equivalent.

Every circuit in the drawout case has an auxiliary brush. This is the shorter brush in the case which the connecting plug should engage first. On every current circuit or other circuit with shorting bars, make sure the auxiliary brushes are bent high enough to engage the connecting plug or test plug before the main brushes; otherwise, the CT secondary circuit may be opened where one brush touches the shorting bar before the circuit is completed from the plug to the other main brush.

ADJUSTMENTSTAP PLUG POSITIONINGRATIO MATCHING ADJUSTMENT

To obtain a minimum unbalance current in the differential circuit, means are provided in the STD relay to compensate for unavoidable differences in current transformer ratios. Taps on the relay transformer primary windings are rated 8.7, 5.0, 4.6, 3.8, 3.5, 3.2 and 2.9 amperes for each line current transformer. The tap plugs should be moved to the locations which most nearly match the expected CT currents for the same KVA assumed in each of the power transformer windings. The selection of taps should be guided by the method outlined under CALCULATIONS. The connections plug must be removed from the relay before changing tap positions in order to prevent open-circuiting a CT secondary. A check should be made after changing taps to insure that only one plug is left in any horizontal row of tap holes. Inaccurate calibration and overheating may result if more than one plug is connected to any one winding.

UNBALANCE CURRENT MEASUREMENT

Unbalance current measurement is useful in checking the best tap setting when matching current transformer ratios in the field. It is also useful in detecting errors or faults in the current transformer winding, or small faults within the power transformer itself where the fault current is too low to operate the relay.

The type STD relays have a special arrangement for measuring the unbalance current flowing in the differential circuit without disturbing the relay connection. Provision is made for temporarily connecting a 5 volt high-resistance A.C. voltmeter (1000 or more ohms per volt) across the secondary of the differential current transformer. This may be done by connecting the meter across terminals 8 and 9 (see Figs. 10 and 11). When a perfect match of relay currents is obtained by the ratio matching taps, the voltmeter will read zero, indicating no unbalance. If the voltmeter reads 1.5 volts or less, the unbalance current entering or leaving a given tap equals approximately 0.03 times the voltmeter reading times the tap rating. For higher voltmeter readings, the approximate unbalance current may be calculated by substituting the voltage reading and tap rating into the following equation:

$$I (\text{Unbalance}) = (0.16V - 0.2) \times \text{Tap}'$$

The unbalance percentage equals 100 times the unbalance current divided by the measured tap current. For a three winding bank, this must be checked with load on at least two pairs of windings in order to insure that the connections are correct.

The curves in Fig. 16 show the approximate voltage across terminals 8 and 9 required to operate the relay for various percent slope tap settings and through currents expressed as percentage of tap. To insure a margin of safety against false operation, the unbalance voltage should not exceed 75 percent of that required to operate the relay for any given through current and percent slope tap setting. This extent of unbalance may result from the relatively high error currents of low ratio bushing CT's at low multiples of tap current.

This curve represents the STD relay characteristic. Measurement of a voltage across studs 8 and 9 which is 75% or less of the value given on the curve does not necessarily indicate that the relay will operate at higher through current values. This is especially true where very high through faults may cause CT saturation.

Small rectifier-type AC voltmeters are suitable for the measurement of unbalance. The voltmeter should not be left permanently connected since the shunt current it draws reduces the relay sensitivity.

PERCENT SLOPE SETTING

Scribe marks for 15, 25 and 40 percent slope settings are provided in both the STD15 and STF16 relays. It is common practice to use the 25 percent setting unless special connections make it advisable to use one of the others. See the corresponding heading under CALCULATIONS for further details.

OPERATION

TARGETS

Targets are provided for both the seal-in unit and the instantaneous overcurrent unit. In the event of an internal fault, one or both of these units will operate depending upon the fault magnitude. This will produce a target indication of the particular unit which operates. After a fault is cleared, the target should be reset by the reset slide located at the lower left hand corner of the relay.

DISABLING OF TYPE STD RELAY

When by-passing a breaker for maintenance, it will be necessary to disable the relay to prevent false tripping. If the disabling of the relay is done by a remote switch rather than by removing the relay connection plug, the following precautions should be taken:

1. The relay may be disabled by short-circuiting studs 8 and 9 of the relay or by opening the trip circuit at stud 1.
2. If the CT secondaries are short-circuited as part of the disabling procedure, the trip circuit should be opened at stud 1 and studs 8 and 9 should be short circuited first. It is not sufficient to rely on short circuiting the CT secondaries alone, because any difference in time of shorting them may cause false tripping.

MAINTENANCE

CONTACT CLEANING

For cleaning contacts, a flexible burnishing tool should be used. This consists of a flexible strip of metal with an etched roughened surface, resembling in effect a superfine file. The polishing action is so delicate that no scratches are left, yet corroded material will be removed rapidly and thoroughly. The flexibility of the tool insures the cleaning of the actual points of contact.

Contacts should not be cleaned with knives, files or abrasive paper or cloth. Knives or files may leave scratches which increase arcing and deterioration of the contacts. Abrasive paper or cloth may leave minute particles of insulating abrasive material in the contacts and thus prevent closing.

The burnishing tool described is included in the standard relay tool kit obtainable from the factory.

PERIODIC TESTS

An operation test and inspection of the relay and its connections should be made at least once every six months. Tests may be performed as described under INSTALLATION TESTS or, if desired, they may be made on the service taps as described in this section.

When inserting or withdrawing a test plug with T-shaped through jumpers to complete the trip circuit through the test plug, similar through jumpers should also be used on studs 8 and 9 to maintain the connections from the relay to the case. If this is not done, there is a risk of false tripping upon inserting or withdrawing the plug.

PICKUP

The method for checking pickup is as described under the heading INSTALLATION TESTS except, of course, pickup current will be different depending upon the WDG 1 service tap. Pickup value may be determined as follows:

$$I_1 = 0.30 \times \text{WDG 1 Tap}$$

Of course, when checking pickup on a particular service tap, the ± 10 percent expected variation still applies, the acceptable as found values being

$$I_1 = 0.90 \times 0.30 \times \text{WDG 1 Tap to } 1.10 \times 0.30 \times \text{WDG 1 Tap}$$

Example WDG 1 Tap = 3.5A

$$I_1 = 0.90 \times 0.30 \times 3.5 \text{ to } 1.10 \times 0.30 \times 3.5$$

$$I_1 = 0.94 \text{ to } 1.16 \text{ amperes}$$

HARMONIC CURRENT RESTRAINT

The procedure for checking harmonic restraint is as described under the heading INSTALLATION TESTS except the test current values must be modified as follows:

$$I_2 \text{ (DC)} = 0.80 \times \text{WDG 1 Tap}$$

$$I_1 = 0.90 \times \text{WDG 1 Tap to } 1.10 \times \text{WDG 1 Tap}$$

In the event a suitable DC meter is not available, $I_2 \text{ (AC)} = 2.25 \times I_2 \text{ (DC)}$. (Theoretically this conversion factor would be 2.22 if the rectifier back resistance were infinite).

Example WDG 1 Tap = 3.5A

$$I_2 \text{ (DC)} = 0.80 \times 3.5 = 2.8 \text{ amperes}$$

$$I_1 = 0.90 \times 3.5 \text{ to } 1.10 \times 3.5$$

$$I_1 = 3.15 \text{ to } 3.85 \text{ amperes}$$

If DC meter is not available, $I_2 \text{ (AC)} = 2.25 \times 2.8 = 6.30 \text{ amperes}$

THROUGH CURRENT RESTRAINT

In order to check the service tap slope setting, the test current values indicated in Table IV must be modified to take into account any difference in tap settings. Furthermore, the test circuit shown in Fig. 14 must be set up such that the lead from ammeter 13 to the test plug is connected to the stud setting. The common lead, of course, is connected to the stud corresponding to the winding with the higher tap setting. For any combination of taps, the percent slope is given by the following equation:

$$\% \text{ Slope} = \left[\frac{T_1}{T_2} \left(\frac{I_1}{I_3} + 1 \right) - 1 \right] \times 100$$

where

T_1 = smaller tap setting

T_2 = higher tap setting

I_1 = differential current

I_3 = smaller of the two through currents

Table V derived from the above expression and is based on a multiple of tap current of six times the lower tap setting for all combinations of taps except those which involve the 8.7 amp tap. For the latter case, a four times tap setting is used since the total test current for a six times tap setting may be as high as 75.2 amperes which is not only prohibitively high for many installations but also may subject the relay to excessive heating.

For a given tabular value of I_3 corresponding to a given combination of winding and percent slope taps, the values of I_1 (min.) and I_1 (max.) correspond to the minimum and maximum percent slope tolerance limits given in Table III. However, for a four times tap setting, both the upper the lower percent tolerance limits have been raised by a value equivalent to the difference between the true slope and the nominal slope at four times tap value indicated by the percent slope characteristic curves shown in Fig. 1.

Example WDG 1 Tap = 3.5 A
 WDG 2 Tap = 5.0 A
 Slope Tap = 40%

Since WDG 1 has the lower tap setting the lead from ammeter I_3 to the test plug should be connected to stud 6 and the common lead should be connected to stud 6 and the common lead should be connected to stud 4.

From Table V

I_3 = 21.0 amps
 I_1 (min.) = 21.0 amps
 I_1 (max.) = 22.2 amps

RENEWAL PARTS

It is recommended that sufficient quantities of renewal parts be carried in stock to enable the prompt replacement of any that are worn, broken, or damaged.

When ordering renewal parts, address the nearest Sales Office of the General Electric Company, specify quantity required, name of part wanted, and give complete nameplate data, and the serial number which may be found stamped on the instantaneous unit in black ink. If possible, give the General Electric Company requisition number on which the relay was furnished.

TABLE V

TAPS	T1	2.9			3.2			3.5			3.8			4.2			4.6			5.0			8.7					
		15	25	40	15	25	40	15	25	40	15	25	40	15	25	40	15	25	40	15	25	40	15	25	40			
		Slopes																										
		Currents																										
2.9	I_3	17.4	17.4	17.4	17.4	17.4	17.4	17.4	17.4	17.4	17.4	17.4	17.4	17.4	17.4	17.4	17.4	17.4	17.4	17.4	17.4	17.4	17.4	17.4	17.4	11.6	11.6	11.6
	$I_1(\min)$	2.6	4.3	7.0	4.6	6.6	9.5	6.7	8.8	12.0	8.8	11.1	14.5	11.6	14.1	17.9	14.3	17.1	21.2	17.1	20.1	24.6	17.6	20.9	25.8	28.7	32.2	37.4
	$I_1(\max)$	2.9	4.8	7.7	5.0	7.1	10.3	7.1	9.4	12.8	9.2	11.7	15.4	12.0	14.8	18.9	14.8	17.8	22.4	17.6	20.9	25.8	29.3	33.1	38.9			
3.2	I_3				19.2	19.2	19.2	19.2	19.2	19.2	19.2	19.2	19.2	19.2	19.2	19.2	19.2	19.2	19.2	19.2	19.2	19.2	19.2	19.2	19.2	12.8	12.8	12.8
	$I_1(\min)$				2.9	4.8	7.7	4.9	7.0	10.2	7.0	9.3	12.7	9.8	12.3	16.1	12.5	15.3	19.4	15.3	18.3	22.8	27.5	31.0	36.2			
	$I_1(\max)$				3.2	5.3	8.5	5.3	7.6	11.0	7.4	9.9	13.6	10.2	13.0	17.1	13.0	16.0	20.6	15.8	19.1	24.0	28.1	31.9	37.7			
3.5	I_3							21.0	21.0	21.0	21.0	21.0	21.0	21.0	21.0	21.0	21.0	21.0	21.0	21.0	21.0	21.0	21.0	21.0	21.0	14.0	14.0	14.0
	$I_1(\min)$							3.1	5.2	8.4	5.2	7.5	10.9	8.0	10.5	14.3	10.7	13.5	17.6	13.5	16.5	21.0	26.3	29.8	35.0			
	$I_1(\max)$							3.5	5.8	9.3	5.6	8.1	11.8	8.4	11.2	15.3	11.2	14.2	18.8	14.0	17.3	22.2	26.9	30.7	36.5			
3.8	I_3										22.8	22.8	22.8	22.8	22.8	22.8	22.8	22.8	22.8	22.8	22.8	22.8	22.8	22.8	22.8	15.2	15.2	15.2
	$I_1(\min)$										3.4	5.7	9.1	6.2	8.7	12.5	8.9	11.7	15.8	11.7	14.7	19.2	25.1	28.6	33.8			
	$I_1(\max)$										3.8	6.3	10.0	6.6	9.4	13.5	9.4	12.4	17.0	12.2	15.5	20.4	25.7	29.5	35.3			
4.2	I_3													25.2	25.2	25.2	25.2	25.2	25.2	25.2	25.2	25.2	25.2	25.2	25.2	16.8	16.8	16.8
	$I_1(\min)$													3.8	6.3	10.1	6.5	9.3	13.4	9.3	12.3	16.8	23.5	27.0	32.2			
	$I_1(\max)$													4.2	7.0	11.1	7.0	10.0	14.6	9.8	13.1	18.0	24.1	27.9	33.7			
4.6	I_3																27.6	27.6	27.6	27.6	27.6	27.6	27.6	27.6	27.6	18.4	18.4	18.4
	$I_1(\min)$																4.1	6.9	11.0	6.9	9.9	14.4	21.9	25.4	30.6			
	$I_1(\max)$																4.6	7.6	12.2	7.4	10.7	15.6	22.5	26.3	32.1			
5.0	I_3																			30.0	30.0	30.0	30.0	30.0	30.0	20.0	20.0	20.0
	$I_1(\min)$																			4.5	7.5	12.0	20.3	23.8	29.0			
	$I_1(\max)$																			5.0	8.3	13.2	20.9	24.7	30.5			
8.7	I_3																									34.8	34.8	34.8
	$I_1(\min)$																									5.5	9.0	14.2
	$I_1(\max)$																									6.1	9.9	15.7

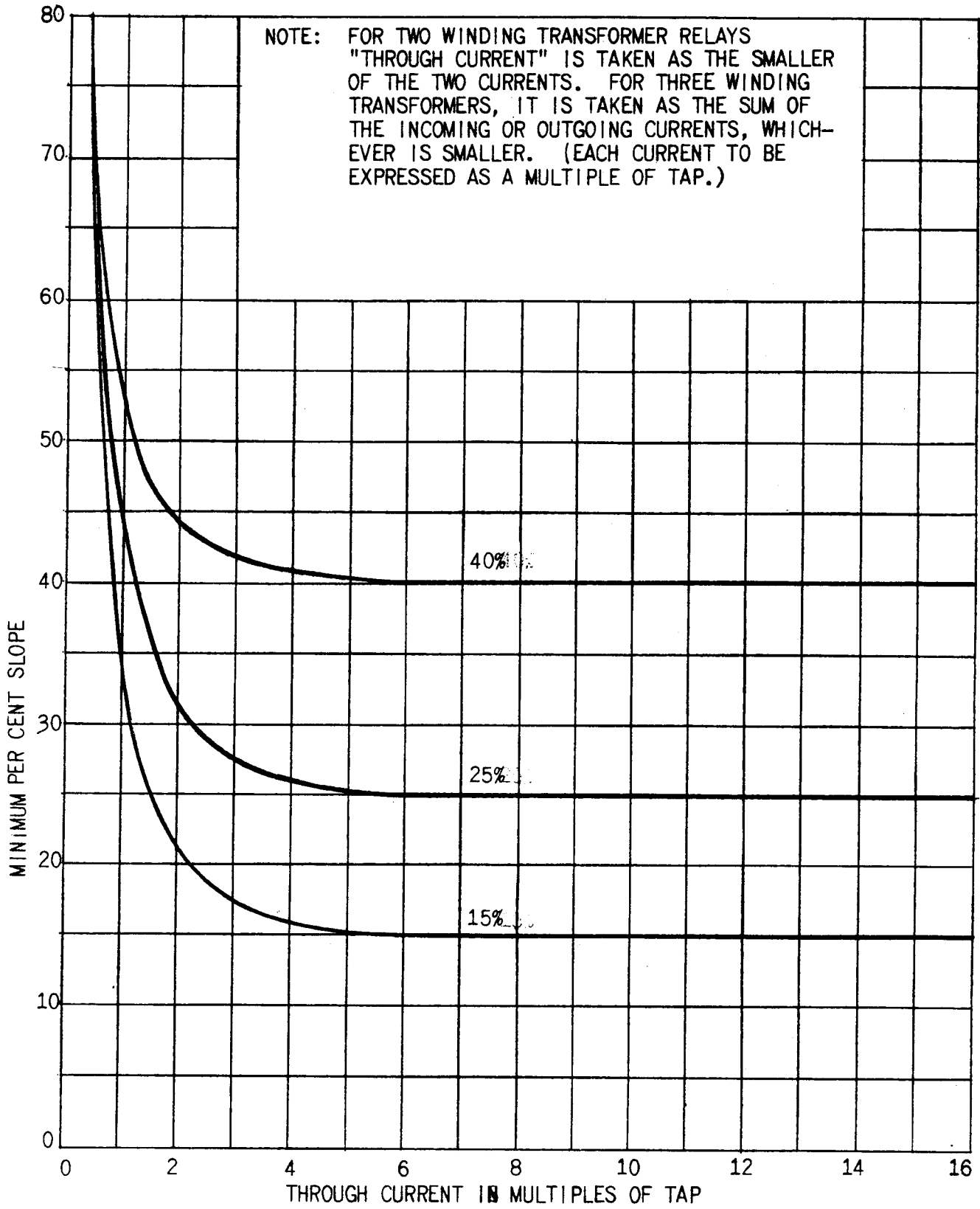

FIG. 1 (0378A588-3) LOW CURRENT SLOPE CHARACTERISTICS OF THE STD RELAY

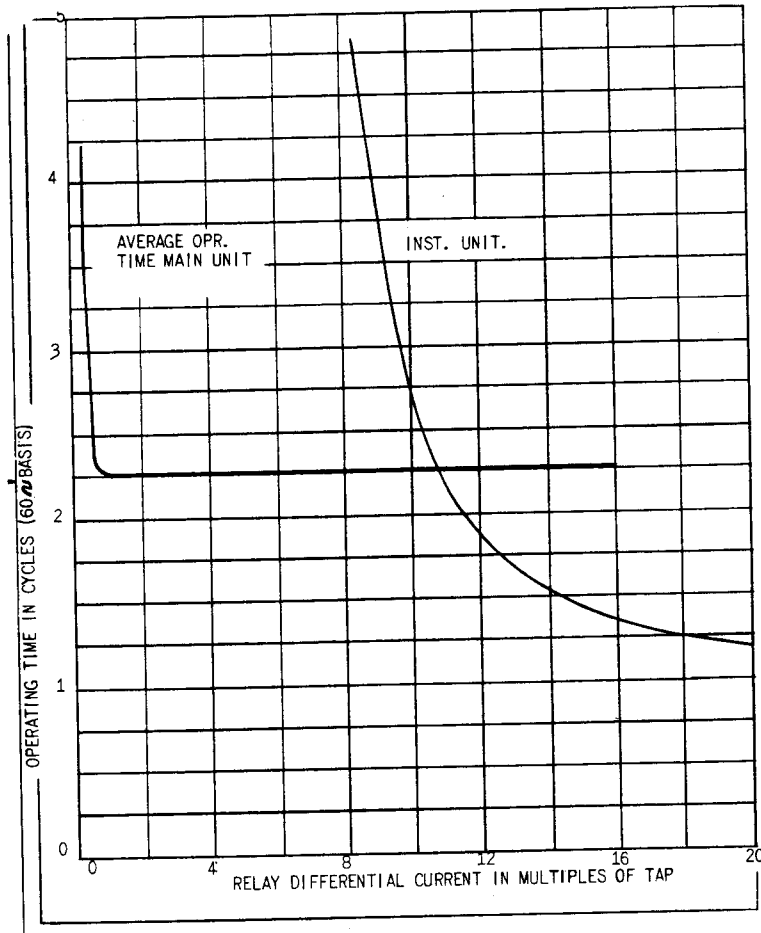
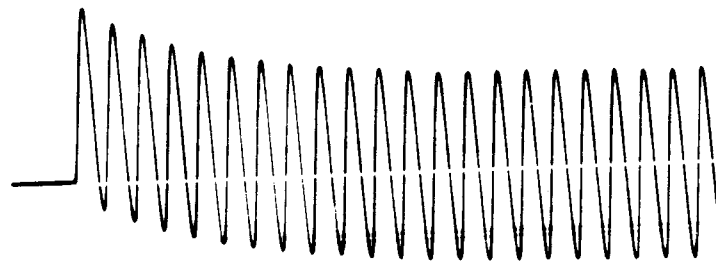
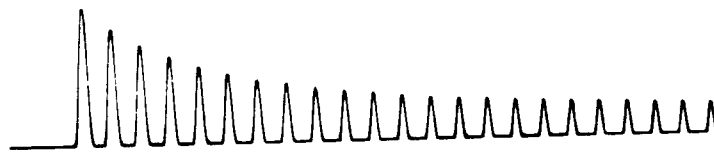

FIG. 2 (0227A2503-0) OPERATING SPEED CHARACTERISTICS OF THE STD RELAY



TYPICAL OFFSET FAULT CURRENT WAVE



TYPICAL TRANSFORMER
MAGNETIZING INRUSH CURRENT WAVE

FIG. 3 (K-6209195-0) FAULT CURRENT AND TRANSFORMER MAGNETIZING CURRENT WAVES

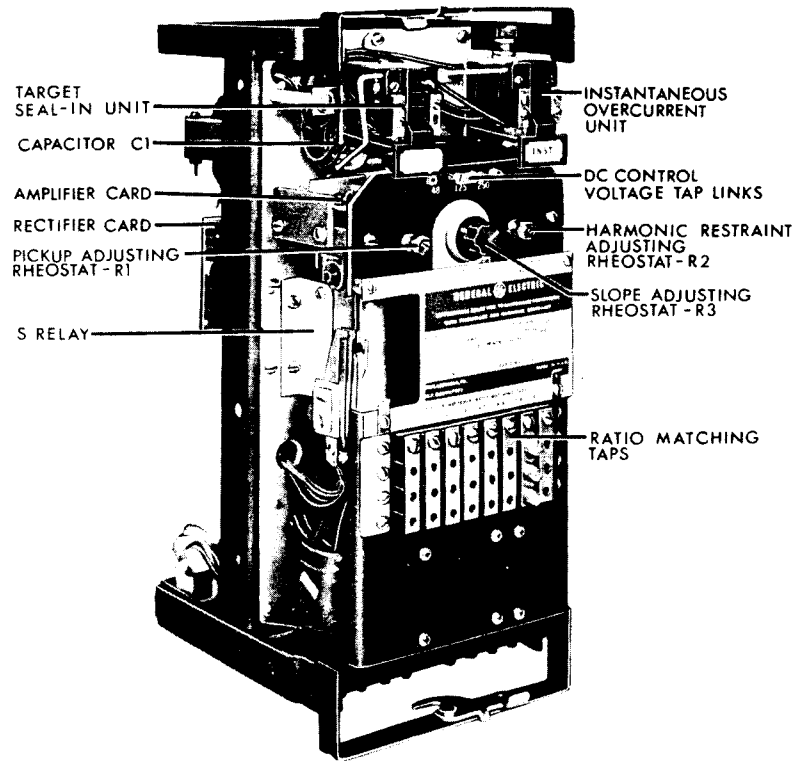

FIG. 4A (8042539) RELAY TYPE STD16C OUT OF CASE, APPROX 3/4 FRONT VIEW (LEFT SIDE)

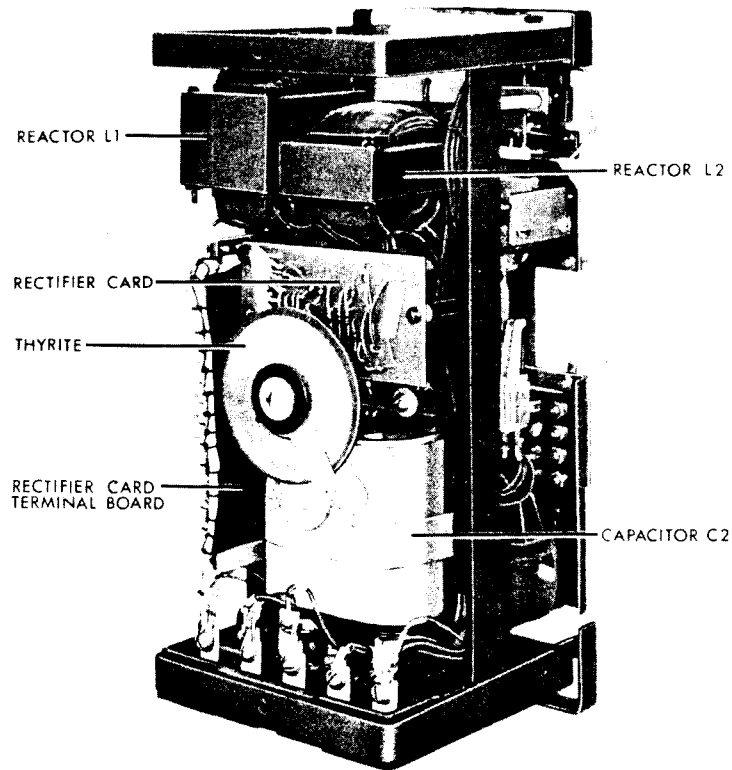

FIG. 4B (8042544) RELAY TYPE STD16C OUT OF CASE, APPROX 3/4 BACK VIEW (RIGHT SIDE)

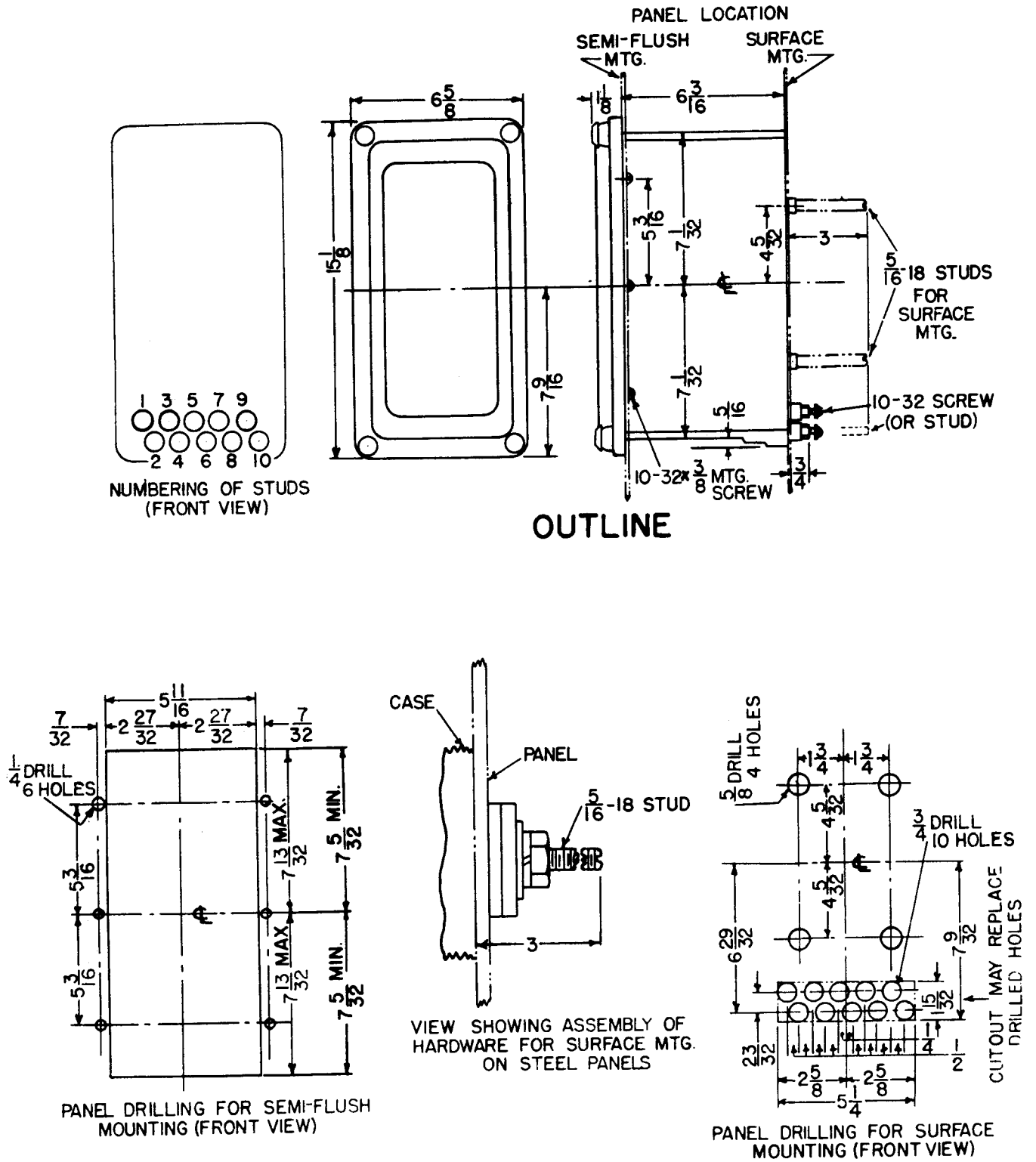
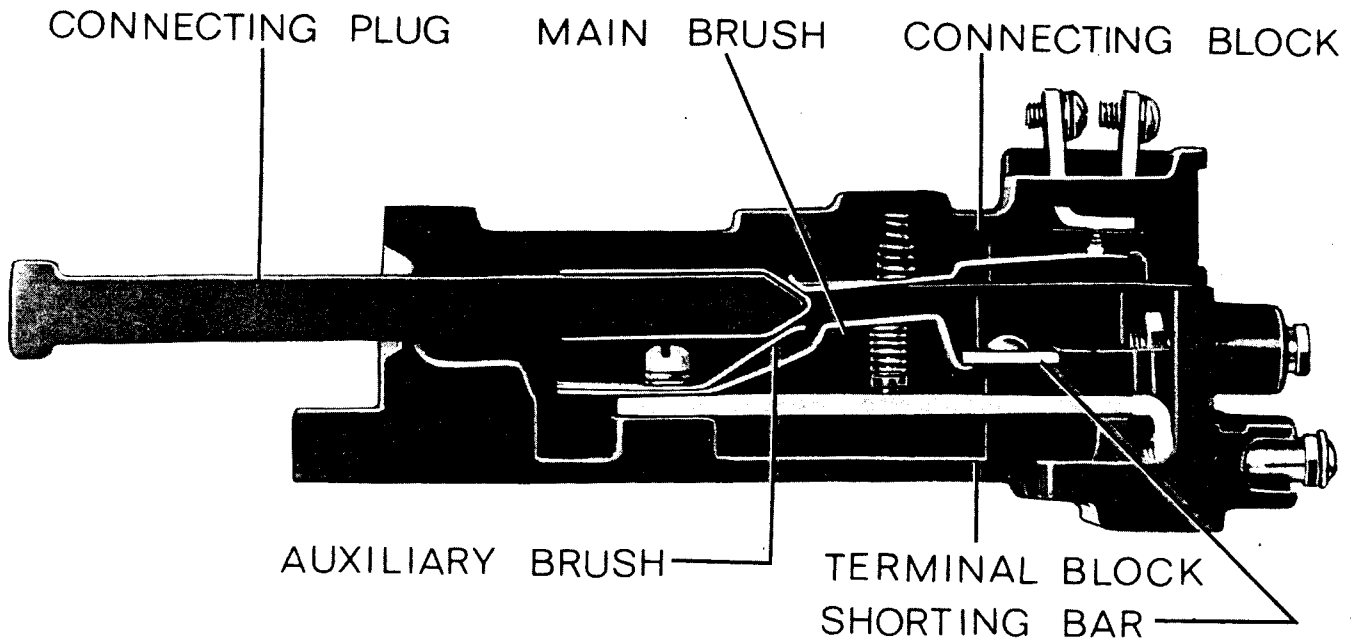

FIG. 5 (K-6209273-2) OUTLINE AND PANEL DRILLING DIMENSIONS FOR MEDIUM SINGLE END (M1) CASE OF RELAY TYPE STD



NOTE: AFTER ENGAGING AUXILIARY BRUSH, CONNECTING PLUG TRAVELS $\frac{1}{4}$ INCH BEFORE ENGAGING THE MAIN BRUSH ON THE TERMINAL BLOCK

FIG. 6 (8025039) CROSS SECTION OF DRAWOUT CASE SHOWING POSITION OF AUXILIARY BRUSH

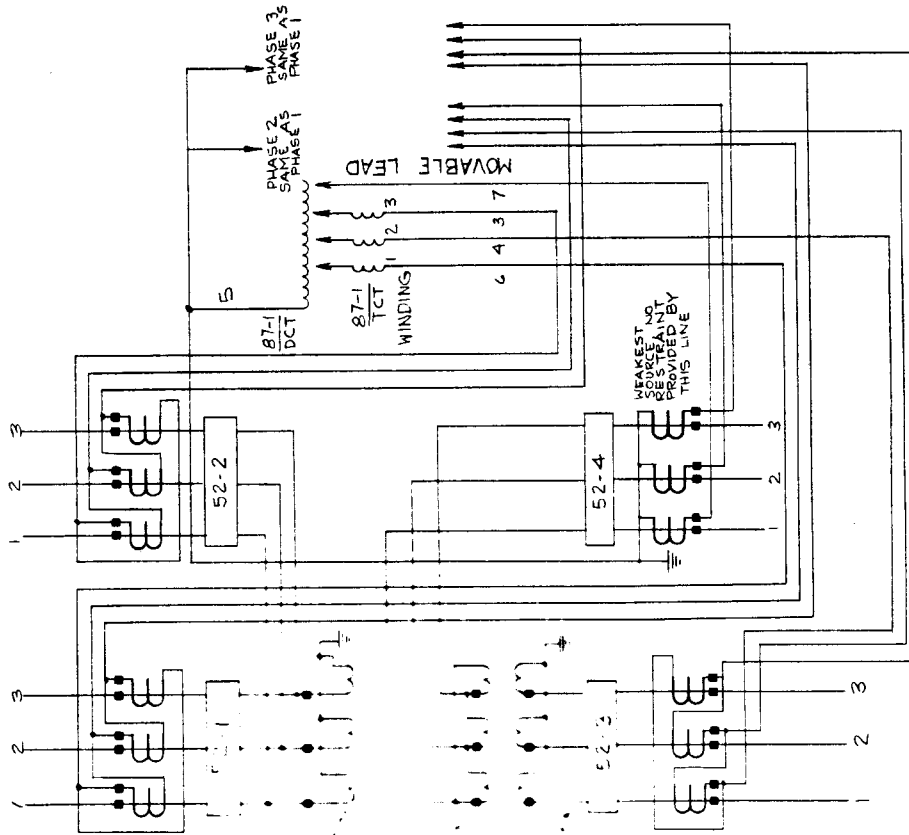
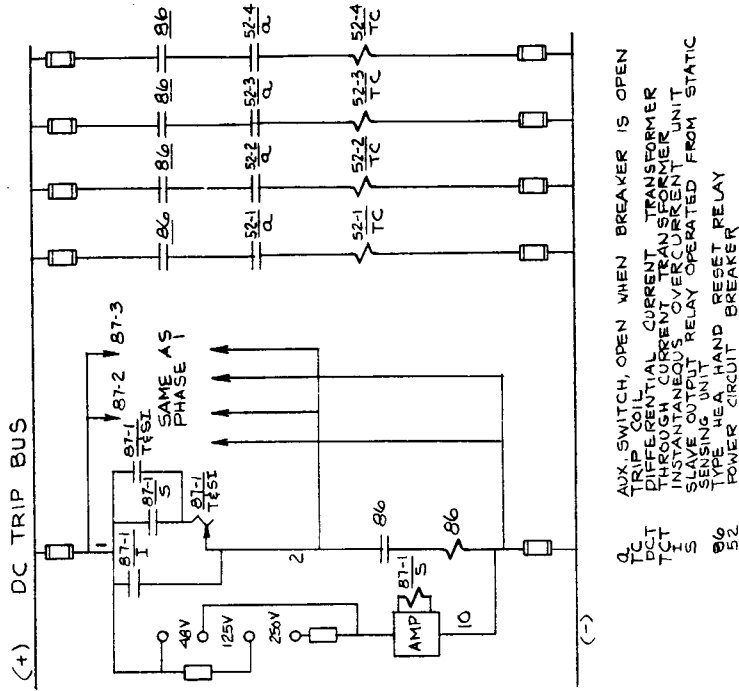

FIG. 9 (0128B1982-3) ELEMENTARY DIAGRAM FOR STD16C RELAYS FOR FOUR CIRCUIT TRANSFORMER PROTECTION WITH THREE RESTRAINTS

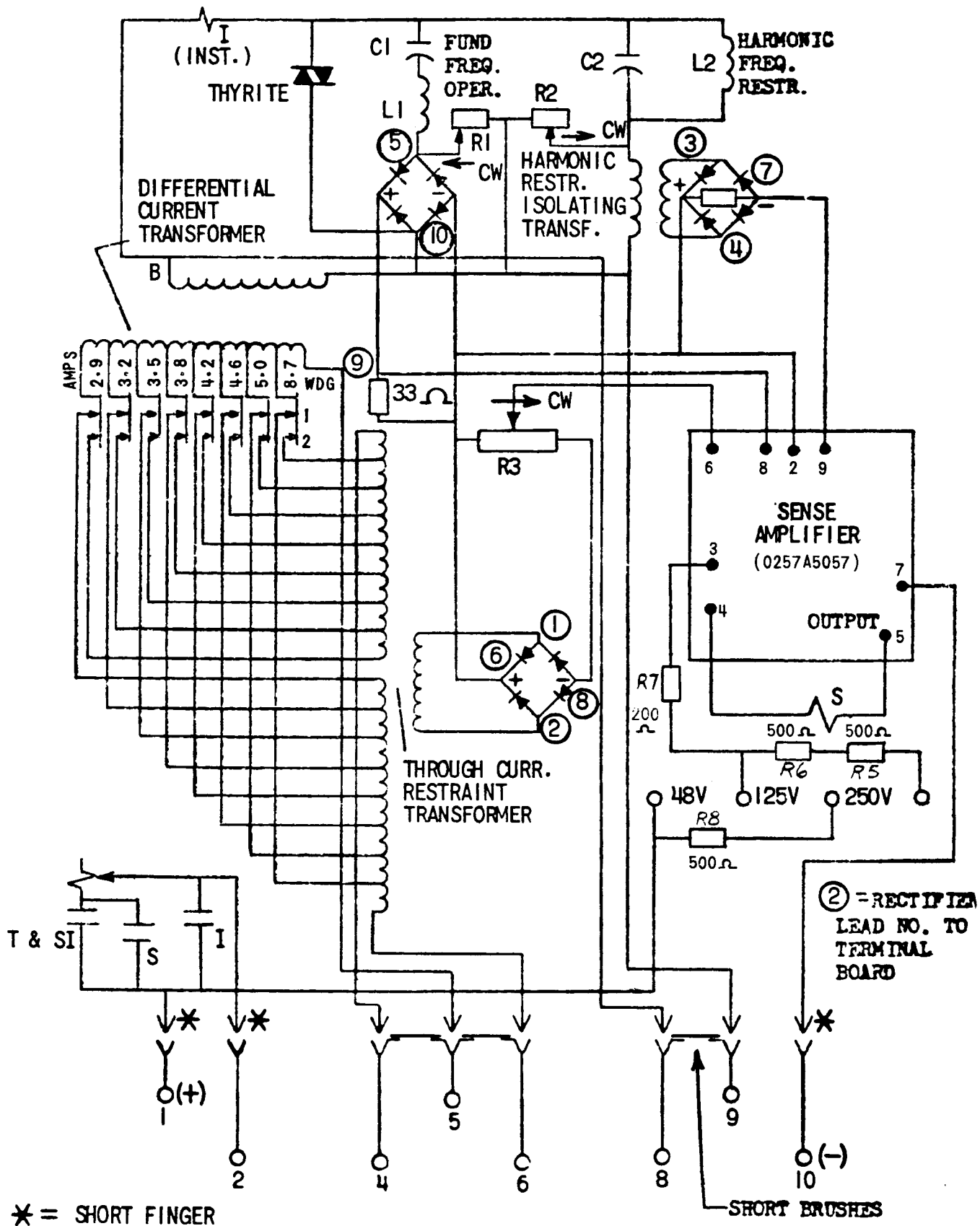

FIG. 10 (0257A502c- INTERNAL CONNECTIONS DIAGRAM FOR RELAY TYPE STD15C

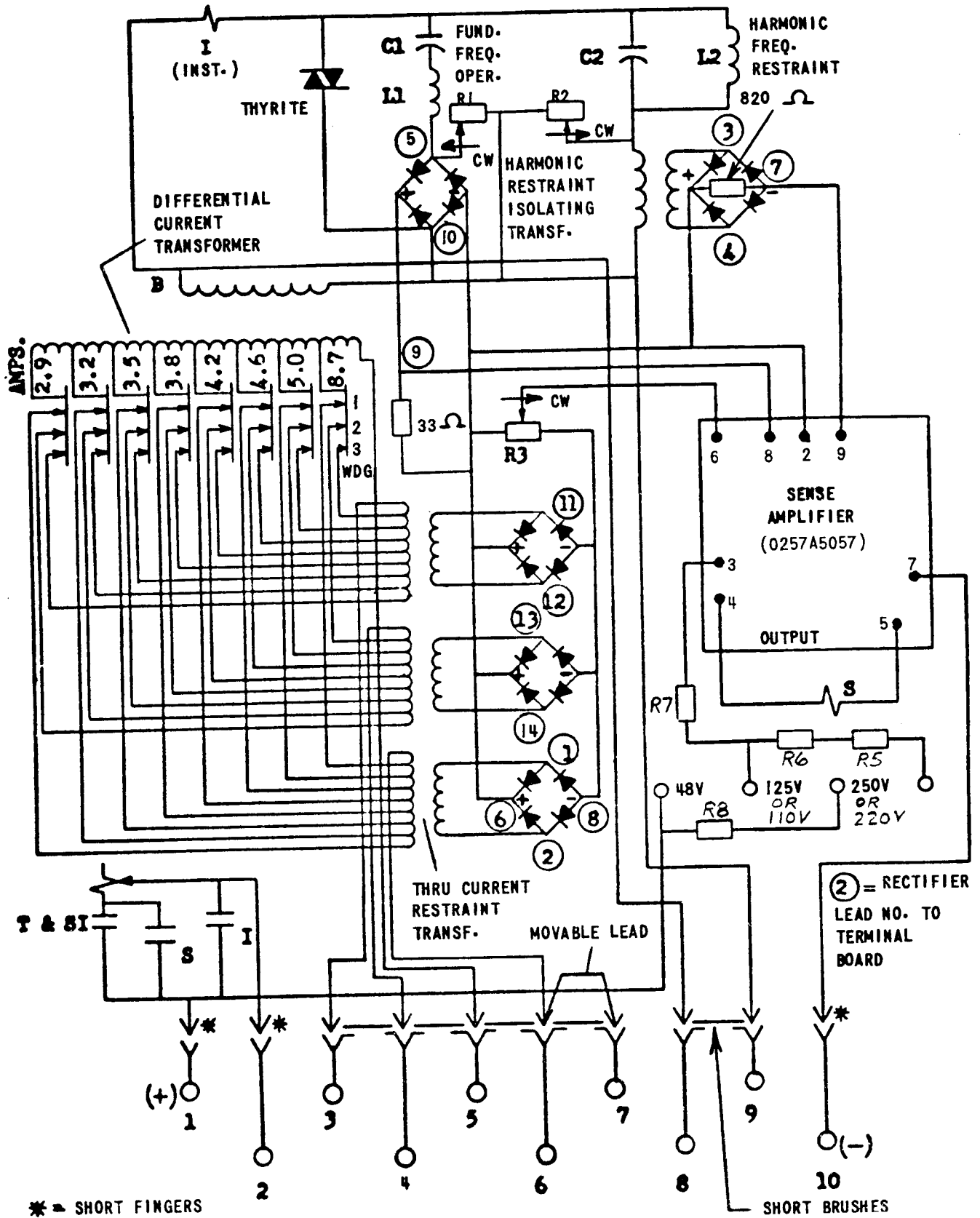
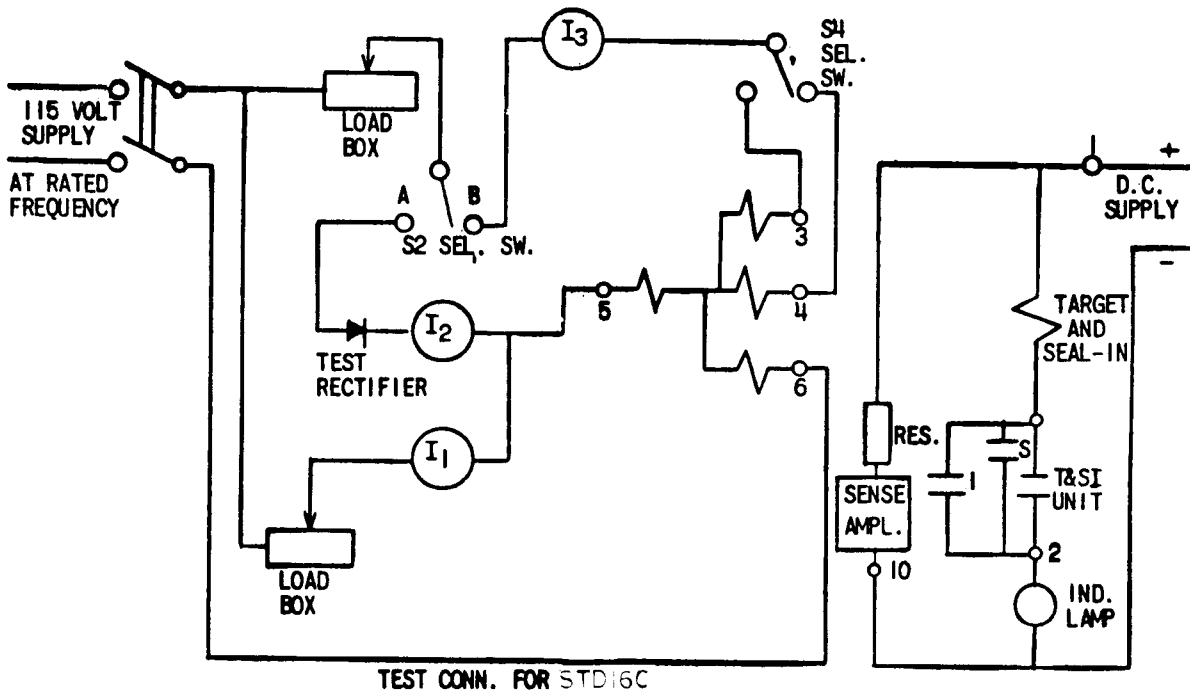
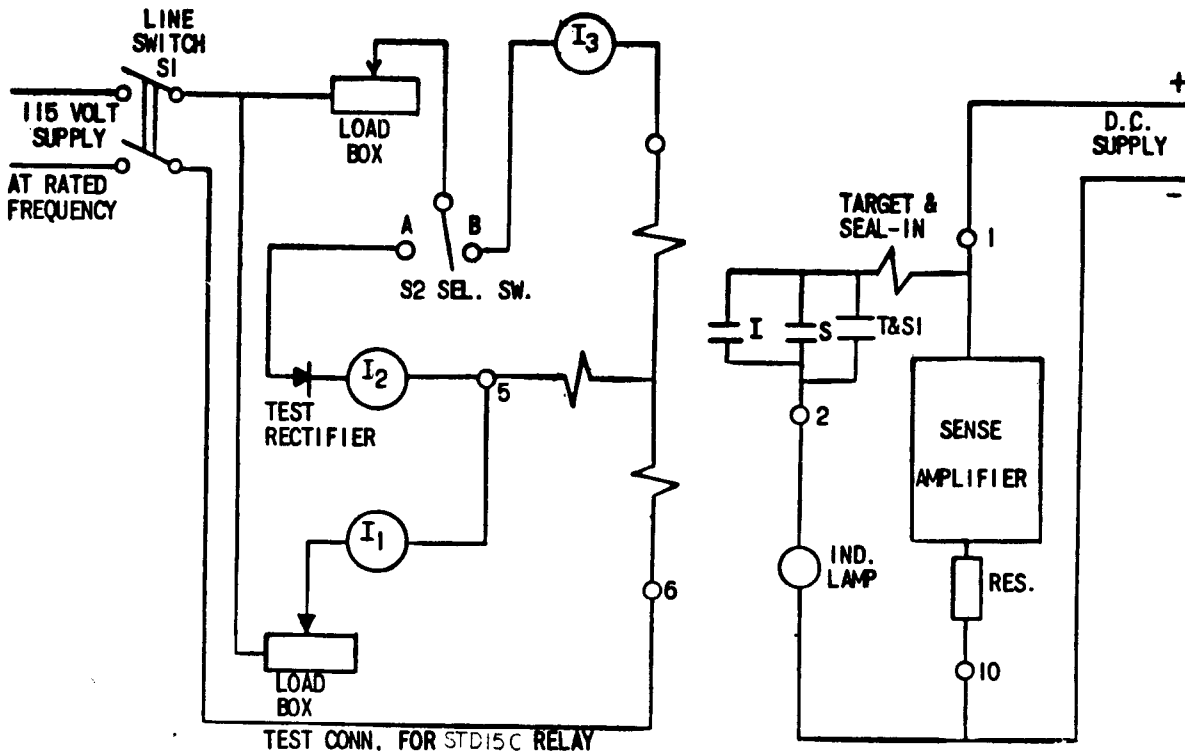

FIG. 11 (0257A5027-0) INTERNAL CONNECTIONS DIAGRAM FOR RELAY TYPE STD16C



LEGEND
I = INSTANTANEOUS OVERCURRENT UNIT
T&SI = TARGET AND SEAL-IN UNIT
S = TELEPHONE RELAY

FIG. 12 (0165B2697-0) TEST CONNECTIONS DIAGRAM

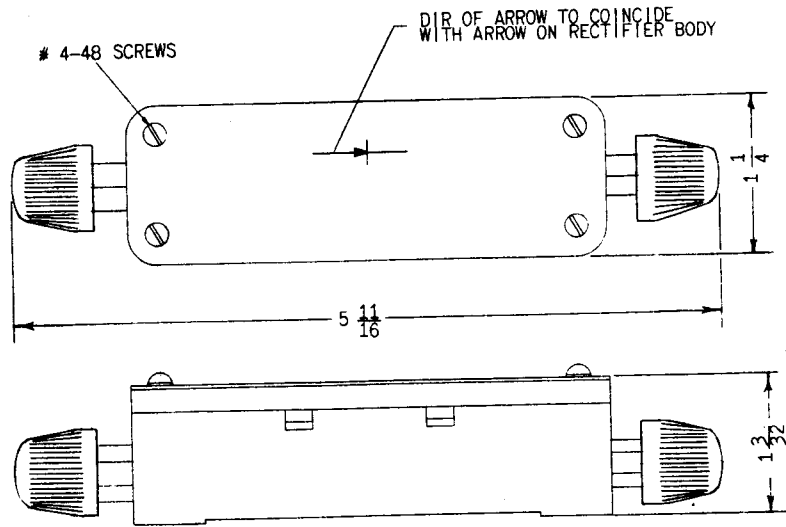

FIG. 13 (0148A2994-1) OUTLINE OF TEST RECTIFIER

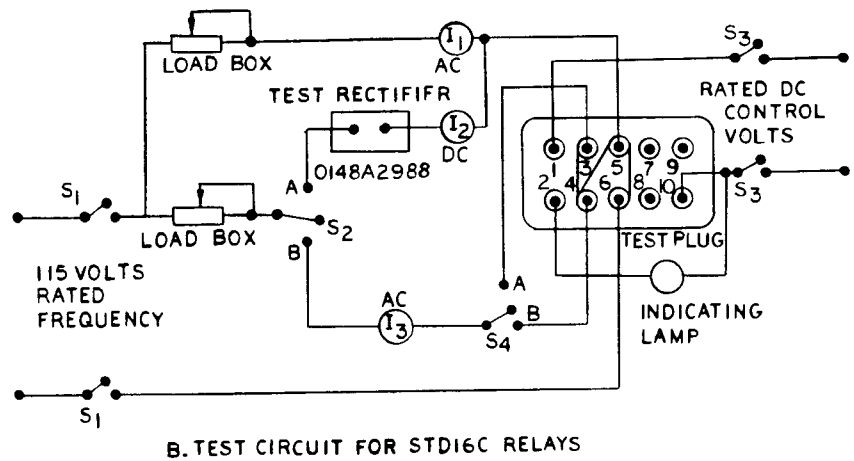
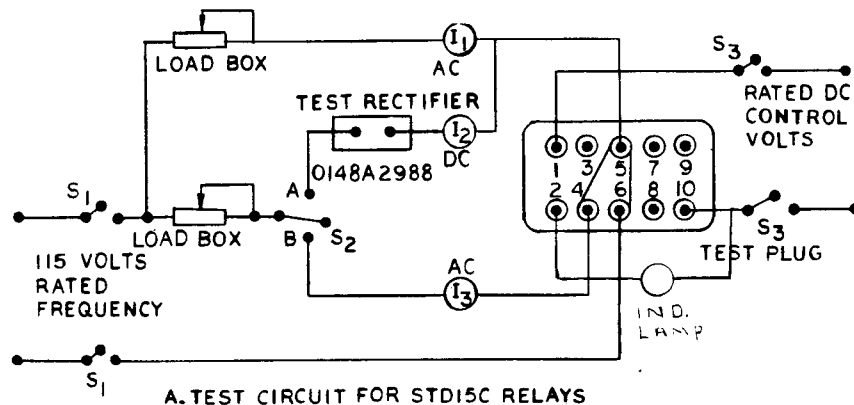

FIG. 14 (0257A5054-0 SH. 1) FIELD TEST CONNECTIONS, IN CASE, USING TYPE XLA TEST PLUG

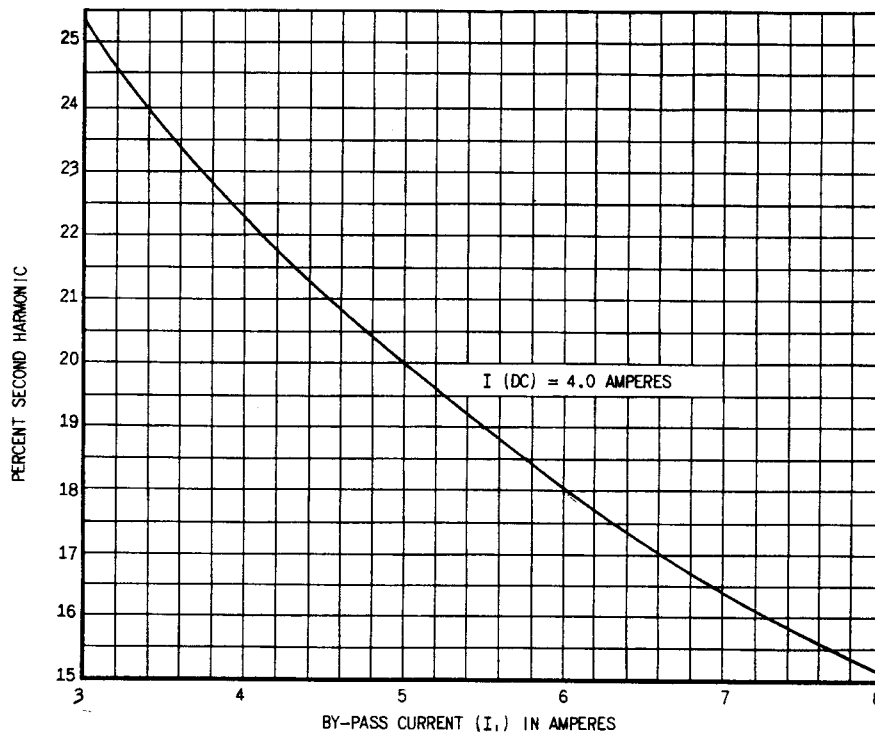

FIG. 15 (418A786-0) RELATIONSHIP BETWEEN PERCENT SECOND HARMONIC AND BY-PASS CURRENT WITH I(DC) SET AT 4.0 AMPERES

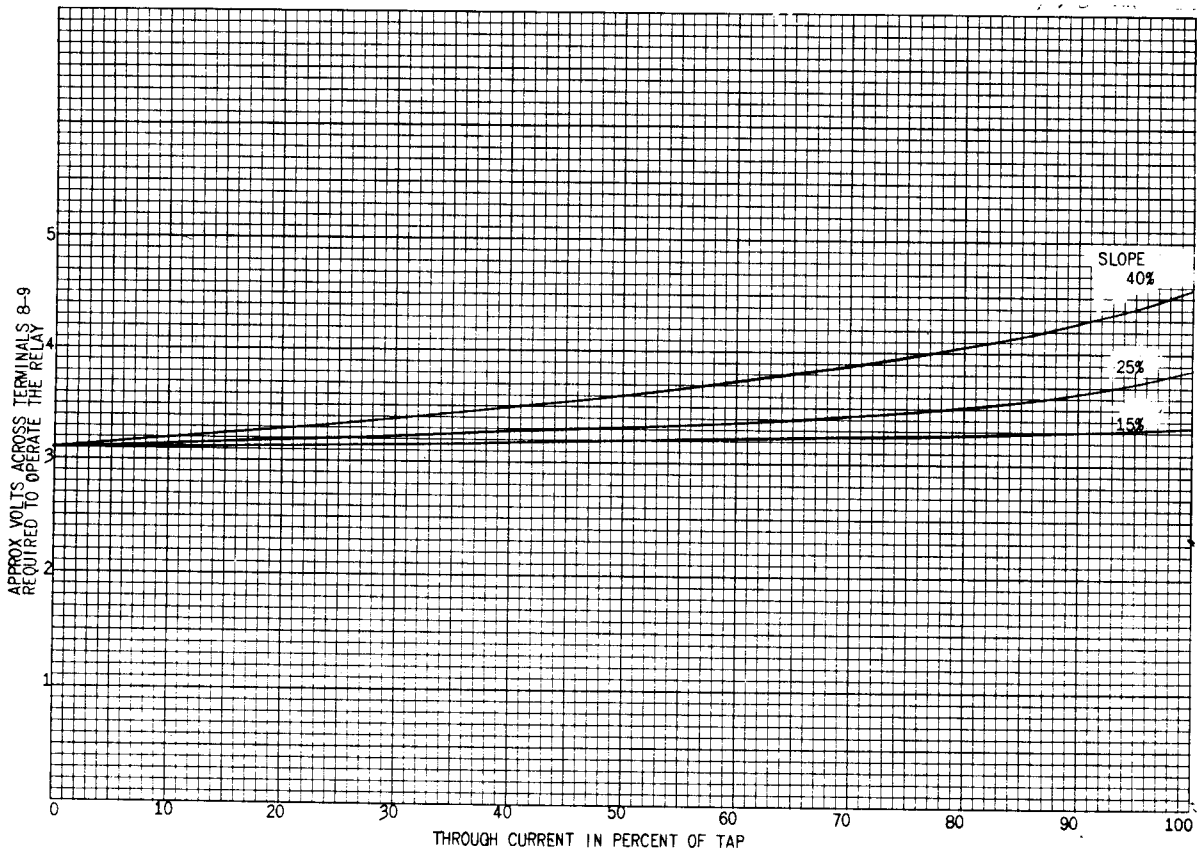

FIG. 16 (0178A8111-0) DIFFERENTIAL VOLTAGE OPERATING CHARACTERISTICS OF TYPE STD RELAY

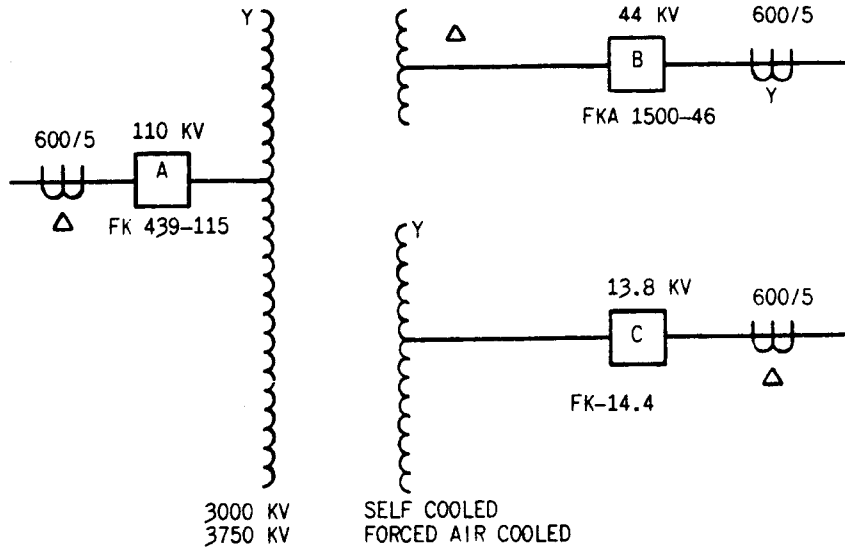

FIG. 17 (0165A7601-0) TRANSFORMER USED IN SAMPLE CALCULATIONS

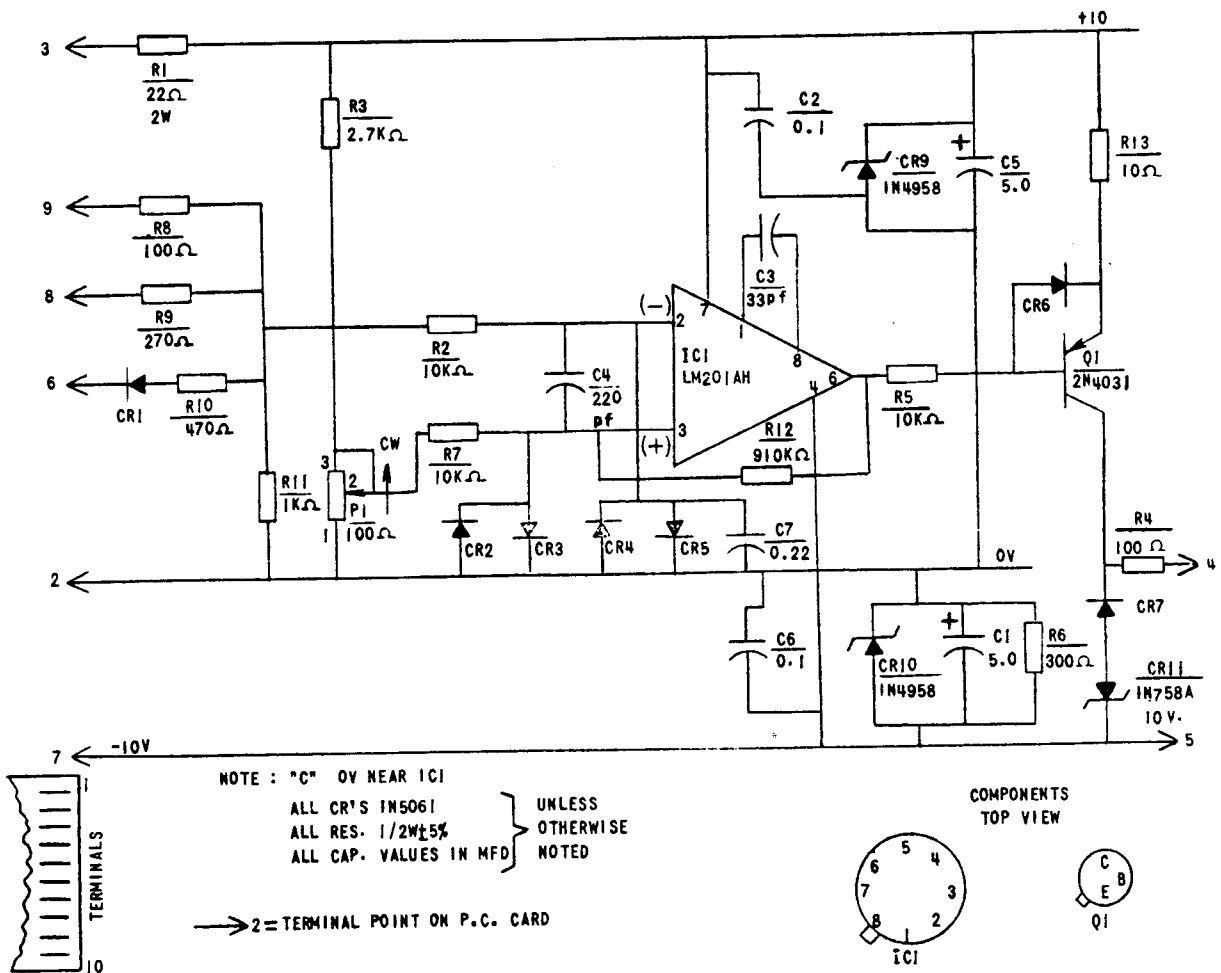

FIG. 18 (0257A5057-0) INTERNAL CONNECTIONS DIAGRAM OF SENSE AMPLIFIER PRINTED CIRCUIT BOARD

INSTRUCTIONS

GEK- 45309
Insert Booklet GEK-45307

TRANSFORMER DIFFERENTIAL RELAY
WITH PERCENTAGE AND HARMONIC
RESTRAINT

TYPE STD17C

POWER SYSTEMS MANAGEMENT DEPARTMENT

GENERAL  ELECTRIC

PHILADELPHIA, PA.

TRANSFORMER DIFFERENTIAL RELAY
WITH PERCENTAGE & HARMONIC
RESTRAINT

TYPE STD17C

INTRODUCTION

These instructions are a supplement to instruction book GEK-45307, which is included in this book. The combination of the two form instructions for the STD17C relay.

DESCRIPTION

The Type STD17C relay is similar to the STD16C except the former has four through current restraint windings and is mounted in the L2 (large, double ended) case.

Figure 1 shows the internal connections diagram for the STD17C relay.

Figure 2 shows the typical external wiring diagram for the STD17C relay.

Figure 3 shows the test circuit for the STD17C relay.

Figure 4 shows the outline and panel drilling for the STD17C L2 relay.

These instructions do not purport to cover all details or variations in equipment nor to provide for every possible contingency to be met in connection with installation, operation or maintenance. Should further information be desired or should particular problems arise which are not covered sufficiently for the purchaser's purposes, the matter should be referred to the General Electric Company.

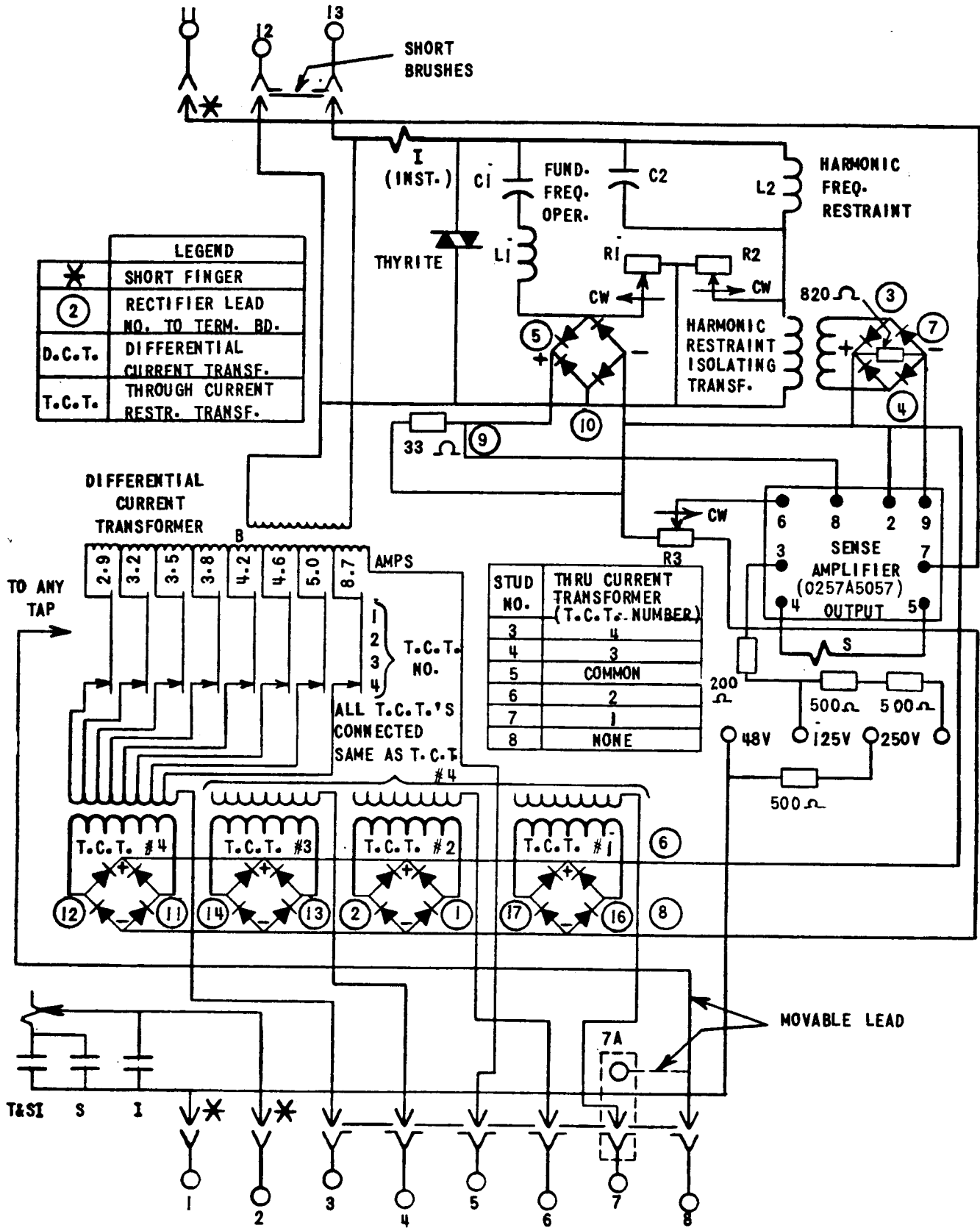

FIG. 1 (0257A5028-0) Internal Connections Diagram For The STD17C Relay (Front View)

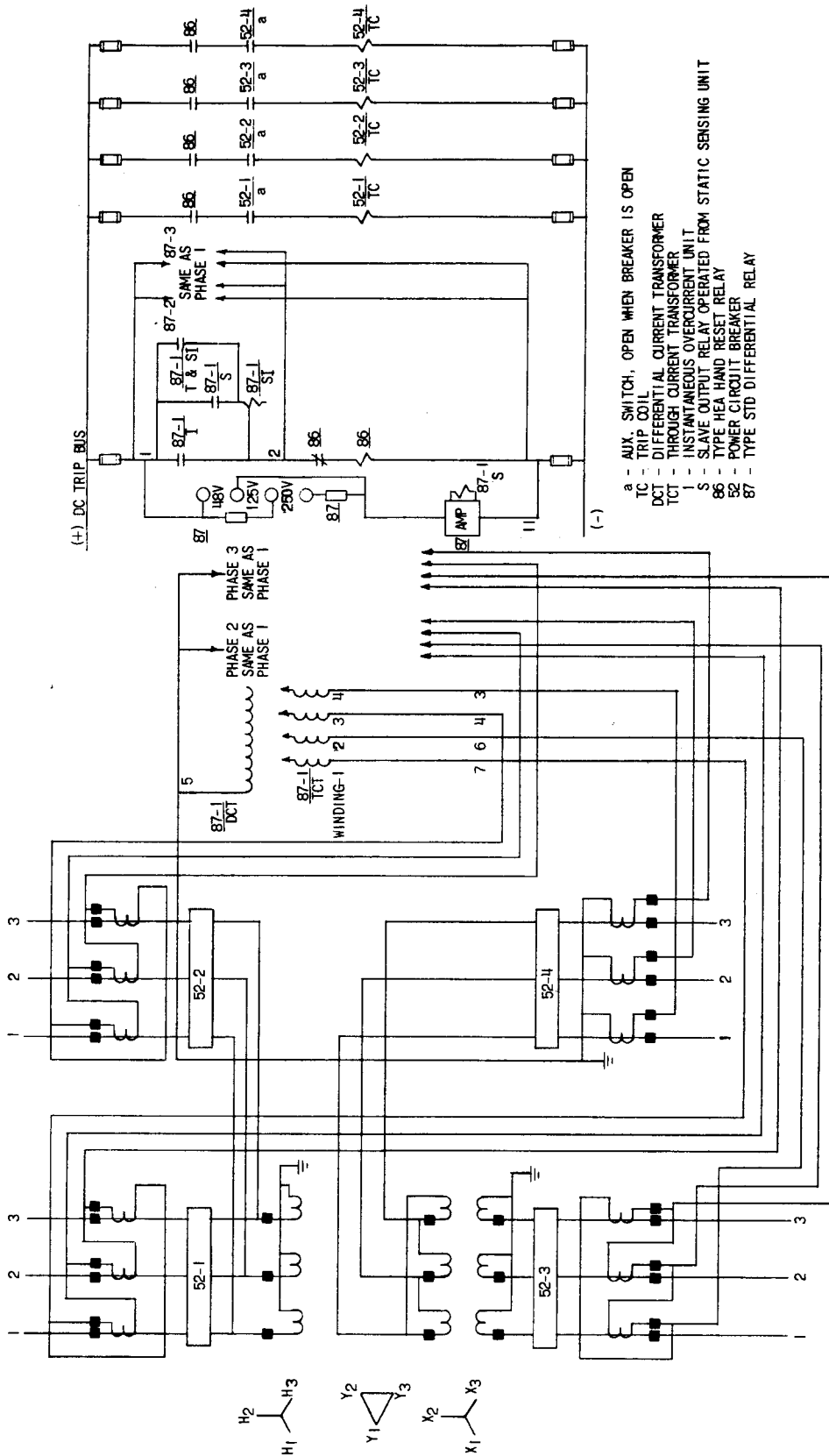
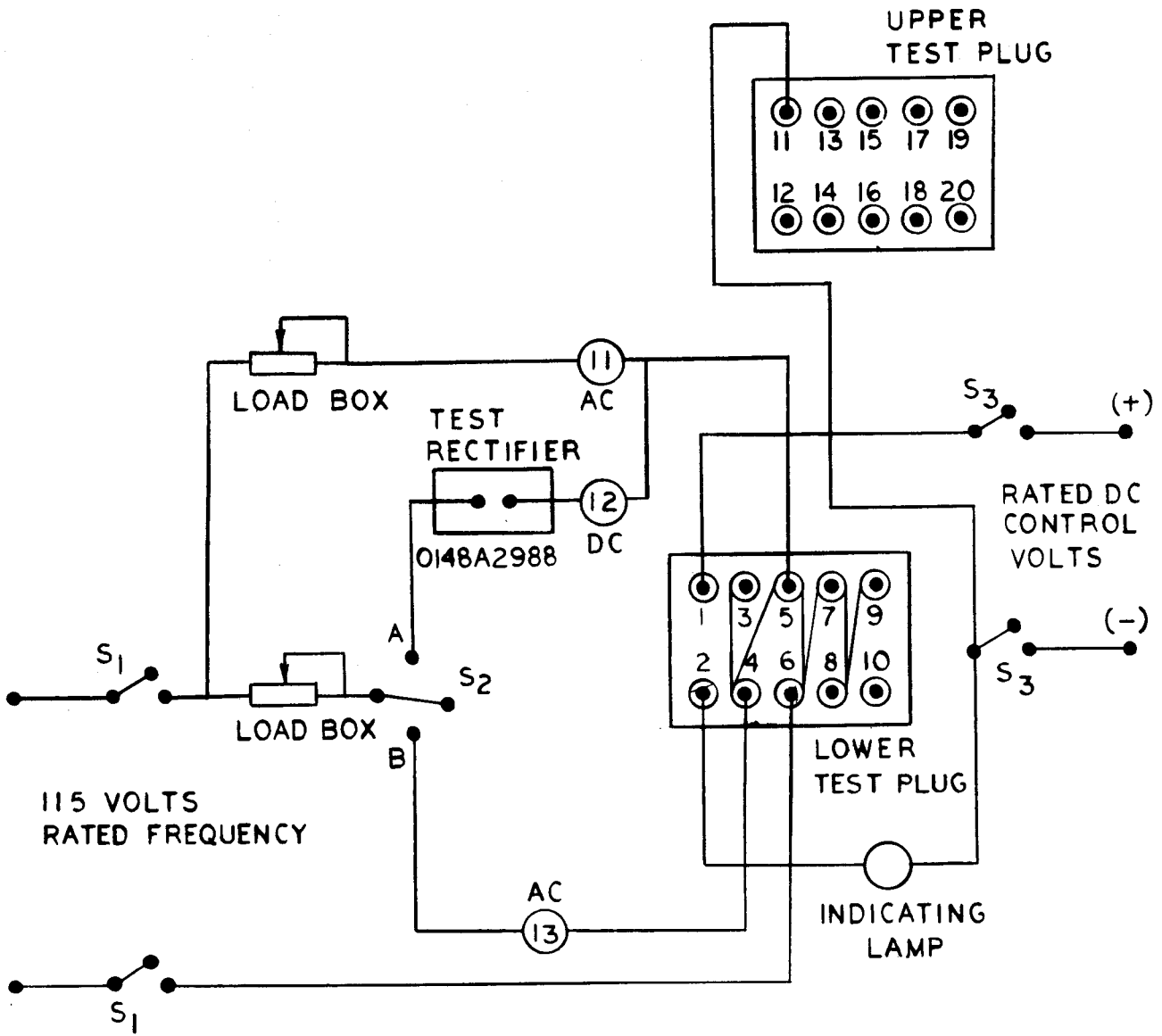

FIG. 2 (0165B2441-0) External Connections Diagram For The STD17C Relay



TEST CIRCUIT FOR STD17C OR STD18C RELAYS

FIG. 3 (0257A5054-C SH. 2) Test Connections Diagram For The STD17C Relay

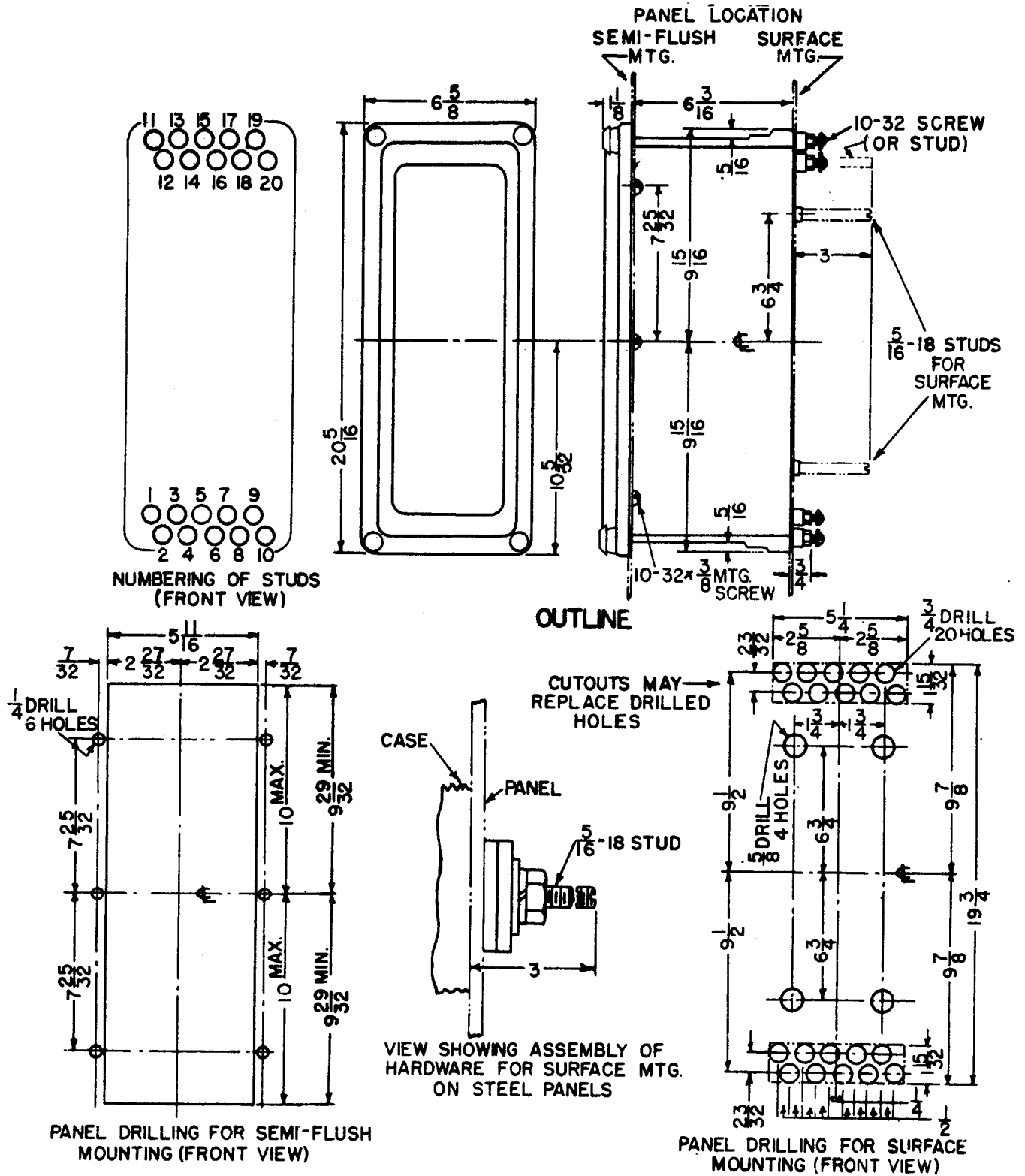

FIG. 4 (K-6209276-1) Outline And Panel Drilling Dimensions For The STD17C Relay

GENERAL ELECTRIC INSTALLATION AND SERVICE ENGINEERING OFFICES

FIELD SERVICE OFFICE CODE KEY

- Mechanical & Nuclear Service
- † Electrical & Electronic Service
- ‡ Marine Service
- ‡ Transportation

FOR YOUR LASTING SATISFACTION . . . with the performance and availability of your General Electric equipment, GE provides this nationwide network of field service offices, serving utility, industrial, transportation and marine users. Qualified field engineers provide installation, start-up, employee training, engineering maintenance and other services, throughout the productive life of the equipment. For full information, call your nearest Installation & Service Engineering office.

ALABAMA
 † Birmingham 35205 2151 Highland Ave.
 • † Mobile 36609 1111 S. Beltline Highway

ALASKA
 † Anchorage 99501 115 Whitney Rd.

ARIZONA
 • † Phoenix 85012 3550 N. Central Ave.
 † Tucson 85718 151 S. Tucson Blvd.

ARKANSAS
 † North Little Rock 72119 120 Main St.

CALIFORNIA
 • † Los Angeles 90054 212 N. Vignes St.
 † Palo Alto 94303 980 San Antonio Rd.
 † Sacramento 95808 2407 J St.
 † San Diego 92103 2560 First Ave.
 • † San Francisco 94119 55 Hawthorne St.
 • † Vernon 90058 3035 E. 46th St.

COLORADO
 • † Denver 80206 201 University Blvd.

CONNECTICUT
 • † Meriden 06450 1 Prestige Dr.

FLORIDA
 † † Jacksonville 32203 4040 Woodcock Dr.
 † † Miami 33134 4100 W. Flagler St.
 • † Tampa 33609 2106 S. Lois Ave.

GEORGIA
 • † Atlanta 30309 1860 Peachtree Rd., NW
 † Savannah 31405 5002 Paulsen St.

HAWAII
 • † Honolulu 96813 440 Coral St.

ILLINOIS
 • † † Chicago 60680 840 S. Canal St.

INDIANA
 † Evansville 47705 2709 Washington Ave.
 † Fort Wayne 46807 3806 S. Calhoun St.
 • † Indianapolis 46207 3750 N. Meridian St.

IOWA
 † Davenport 52805 P. O. Box 630, 1039 State St., Bettendorf

KENTUCKY
 † Louisville 40218 2300 Meadow Dr.

LOUISIANA
 • † Baton Rouge 70806 8312 Florida Blvd.
 • † New Orleans 70125 4747 Earhart Blvd.
 • † Shreveport 71104 2620 Centenary Blvd.
 † Monroe 71201 1028 North 6th St.

MARYLAND
 • † Baltimore 21201 1 N. Charles St.

MASSACHUSETTS
 • † † Wellealey 02181 1 Washington St.

MICHIGAN
 • † † Detroit 48202 700 Antoinette St.
 † † Jackson 49201 210 W. Franklin St.
 † Saginaw 48607 1008 Second National Bank Bldg.

MINNESOTA
 • † † Duluth 55802 300 W. Superior St.
 • † † Minneapolis 55416 1500 Lilac Drive So.

MISSOURI
 • † Kansas City 64199 911 Main St.
 • † St. Louis 63101 1015 Locust St.

MONTANA
 † Butte 59701 103 N. Wyoming St.

NEBRASKA
 • † Omaha 68102 409 S. 17th St.

NEW JERSEY
 • † Millburn 07041 25 E. Willow St.

NEW YORK
 • † Albany 12205 15 Computer Drive, West
 • † † Buffalo 14205 825 Delaware Ave.
 • † † New York 10022 641 Lexington Ave.
 • † Rochester 14604 89 East Ave.
 • † Syracuse 13206 3532 James St.

NORTH CAROLINA
 • † † Charlotte 28207 141 Providence Rd.
 • † † Wilmington
 • † Reigelwood 28456 P. O. Box 186

OHIO
 • † Cincinnati 45206 2621 Victory Pkwy.
 • † † Cleveland 44104 1000 Lakeside Ave.
 † Columbus 43229 1110 Morse Rd.
 † Toledo 43606 3125 Douglas Rd.
 † Youngstown 44507 272 Indianola Ave.

OKLAHOMA
 • † Oklahoma City 73106 2000 Classen Blvd.
 † Tulsa 74105 P. O. Box 7646, Southside Sta.

OREGON
 † Eugene 97401 1170 Pearl St.
 • † † Portland 97210 2929 NW 29th Ave.

PENNSYLVANIA
 • Allentown 18102 1444 Hamilton St.
 • † † Philadelphia 19102 3 Penn Center Plaza
 • † Pittsburgh 15222 300 6th Avenue Bldg.

SOUTH CAROLINA
 † † Columbia 29204 2700 Middleburg Dr.
 † Greenville 29607 41 No. Pleasantsburg Dr.

TENNESSEE
 • † Chattanooga 37411 5800 Bldg, Eastgate Center
 † Memphis 38130 3385 Airways Blvd.

TEXAS
 • † Amarillo 79101 303 Polk St.
 • † † Beaumont 77704 1385 Calder Ave.
 • † Corpus Christi 78401 205 N. Chaparral St.
 † Dallas 75222 8101 Stemmons Freeway
 • † El Paso 79945 215 N. Stanton
 • † Fort Worth 76102 408 W. Seventh St.
 • † † Houston 77027 4219 Richmond Ave.
 † San Antonio 78204 434 S. Main St.

UTAH
 † Salt Lake City 84111 431 S. Third East St.

VIRGINIA
 • † Newport News 23601 311 Main St.
 † Richmond 23230 1508 Willow Lawn Dr.
 † Roanoke 24015 2018 Colonial Ave.

WASHINGTON
 • † † Seattle 98188 112 Andover Park East, Tukwila
 † Spokane 99202 E. 1805 Trent Ave.

WEST VIRGINIA
 • † Charleston 25328 306 MacCorkle Ave., SE

WISCONSIN
 • Appleton 54911 3003 West College Dr.
 † Milwaukee 53202 615 E. Michigan St.

GENERAL ELECTRIC SERVICE SHOPS

WHEN YOU NEED SERVICE . . . These GE Service Shops will repair, recondition, and rebuild your electric apparatus. The facilities are available day and night, seven days a week, for work in the shops or on your premises. Latest factory methods and genuine GE renewal parts are used to maintain performance of your equipment. For full information about these services, contact your nearest service shop or sales office.

ALABAMA
 • Birmingham 35211 1500 Mims Ave., S. W.
 • Mobile 36609 721 Lakeside Dr.

ARIZONA
 • (Phoenix) Glendale 85019 4911 W. Colter St.
 • Phoenix 85019 3840 W. Clarendon St.
 • Tucson 85713 2942 So. Palo Verde Ave.

CALIFORNIA
 • Los Angeles 90301 6900 Stanford Ave.
 • (Los Angeles) Anaheim 92805 3601 E. LaPalma Ave.
 • (Los Angeles) Inglewood 90301 228 W. Florence Ave.
 • Sacramento 95814 99 North 17th St.
 • (San Francisco) Oakland 94608 1650 34th St.

COLORADO
 • Denver 80205 3353 Larimer St.

CONNECTICUT
 • (Southington) Plantville 06479 370 Atwater St.

FLORIDA
 • Jacksonville 32203 2020 W. Beaver St.
 • (Miami) Hialeah 33010 1062 East 28th St.
 • Tampa 33601 19th & Grant Sts.

GEORGIA
 • (Atlanta) Chamblee 30341 5035 Peachtree Industrial Blvd.
 • Atlanta 2379 John Glenn Dr.

ILLINOIS
 • Chicago 60638 6045 S. Nottingham Ave.

INDIANA
 • Evansville 47711 401 N. Congress Ave.
 • Ft. Wayne 46803 1731 Edsall Ave.
 • Hammond 46320 1138 164th Place
 • Indianapolis 46222 1740 W. Vermont St.

IOWA
 • (Davenport) Bettendorf 52722 1025 State St.

KENTUCKY
 • Louisville 40209 3900 Crittenden Drive

LOUISIANA
 • Baton Rouge 70814 10955 North Dual St.
 • New Orleans 70114 1115 DeArmas St.

MARYLAND
 • Baltimore 21230 920 E. Fort Ave.

MASSACHUSETTS
 • (Boston) Medford 02155 3960 Mystic Valley Pkwy.

MICHIGAN
 • (Detroit) Riverview 18075 Krause Ave.
 • Flint 48505 1506 E. Carpenter Rd.

MINNESOTA
 • Duluth 55807 50th Ave. W & St. Louis Bay
 • Minneapolis 55430 2025 49th Ave., N.

MISSOURI
 • Kansas City 64120 3525 Gardner Ave.
 • St. Louis 63110 1115 East Rd.

NEW JERSEY
 • New Brunswick 08902 3 Lawrence St.

NEW MEXICO
 • Albuquerque 87109 4420 McLeod Rd. NE

NEW YORK
 • Albany 12205 1097 Central Ave.
 • (Buffalo) Tonawanda 14150 175 Milens Rd.
 • (Long Island) Old Bethpage 11804 183 Bethpage-Sweet Hollow Rd.
 • (New York City) North Bergen, N. J. 07012 6001 Tonnelle Ave.
 • (New York City) Clifton, N. J. 07012 9 Brighton Rd.
 • Schenectady 12305 1 River Rd.
 • Syracuse 13208 1015 E. Hiawatha Blvd.

NORTH CAROLINA
 • Charlotte 28208 2328 Thrift Rd.

OHIO
 • Akron (Canton) 44720 7900 Whipple Ave. N. W.
 • Cincinnati 45202 444 West 3rd St.
 • Cleveland 44125 4477 East 49th St.
 • Columbus 43229 6660 Huntley Rd.
 • Toledo 43605 405 Dearborn Ave.
 • Youngstown 44507 272 E. Indianola Ave.

OKLAHOMA
 • Tulsa 74145 5220 S. 100th East Ave.

OREGON
 • Eugene 97402 570 Wilson St.
 • Portland 97210 2727 NW 29th Ave.

PENNSYLVANIA
 • Allentown 18103 668 E. Highland St.
 • (Delaware Valley) Cherry Hill, N. J. 08034 1790 E. Marlton Pike
 • Johnstown 15802 841 Oak St.
 • Philadelphia 19124 1040 East Erie Ave.
 • (Pittsburgh) West Mifflin 15122 4930 Buttermill Hollow Rd.
 • York 17403 54 N. Harrison St.

SOUTH CAROLINA
 • (Charleston) No. Charleston 29401 2490 Debonair St.

TENNESSEE
 • Knoxville 37914 2621 Governor John Sevier Hwy.
 • Memphis 38107 708 North Main St.

TEXAS
 • Beaumont 77705 1490 W. Cardinal Dr.
 • Corpus Christi 78401 115 Waco St.
 • Dallas 75235 3202 Manor Way
 • Houston 77036 5534 Harvey Wilson Dr.
 • Houston 77036 6916 Harwin Dr.
 • Midland 79701 704 S. Johnston St.

UTAH
 • Salt Lake City 84110 301 S. 7th West St.

VIRGINIA
 • Richmond 23224 1403 Ingram Ave.
 • Roanoke 24013 1004 River Ave., SE

WASHINGTON
 • Seattle 98134 3422 First Ave., South
 • Spokane 99211 E. 4323 Mission St.

WEST VIRGINIA
 • Charleston 25328 306 MacCorkle Ave., SE

WISCONSIN
 • Appleton Menaaha 54910 1725 Racine St.
 • Milwaukee 53207 235 W. Oklahoma Ave.

• Electrical/Mechanical Service Shop • Instrumentation Shop ∆ Special Manufacturing Shop

