



INSTRUCTIONS

OVERVOLTAGE RELAYS

TYPES IAV, 51D
K
52C
D
K



GENERAL ELECTRIC

DESCRIPTION	3
TABLE A	3
APPLICATION	4
RATINGS	5
TABLE I	5
TABLE II	5
BURDENS	6
TABLE IIIA	6
TABLE IIIB	7
OPERATING CHARACTERISTICS	9
CONSTRUCTION	9
RECEIVING, HANDLING, AND STORAGE	10
RECEIVING	10
HANDLING	10
STORAGE	10
ACCEPTANCE TESTS	10
VISUAL INSPECTION	11
MECHANICAL INSPECTION	11
ELECTRICAL TESTS	12
DRAWOUT RELAYS - GENERAL	12
POWER REQUIREMENTS - GENERAL	12
PICKUP - VOLTAGE TEST	12
TIME-VOLTAGE TEST	12
INSTALLATION	12
INSPECTION	12
LOCATION	13
MOUNTING	13
CONNECTIONS	13
GROUND CONNECTIONS	13
OPERATION	13
ADJUSTMENTS	13
TARGET AND SEAL-IN UNIT	13
VOLTAGE SETTING	14
TIME SETTING	14
PERIODIC CHECKS AND ROUTINE MAINTENANCE	14
MAINTENANCE	15
DISK AND BEARINGS	15
CONTACT CLEANING	15
SERVICING	15
RENEWAL PARTS	15

Cover Photo(8043180)

These instructions do not purport to cover all details or variations in equipment nor provide for every possible contingency to be met in connection with installation, operation or maintenance. Should further information be desired or should particular problems arise which are not covered sufficiently for the purchaser's purposes, the matter should be referred to the General Electric Company.

To the extent required the products described herein meet applicable ANSI, IEEE and NEMA standards; but no such assurance is given with respect to local codes and ordinances because they vary greatly.

OVERVOLTAGE RELAYS

TYPES IAV51D, IAV51K, IAV52C, IAV52D, IAV52K

DESCRIPTION

These are single-phase, sensitive overvoltage relays of the induction disk construction. They are equipped with a time dial so as to provide adjustable time delay in their operation. The relays are principally applicable for sensitive overvoltage ground detection for high-impedance grounded generators or for ungrounded power systems. The differences among the four relays are as indicated in Table A below. Each relay is mounted in a standard size S1 drawout case and the outline and panel drillings are shown in Figs. 14 and 15; Fig. 13 shows the outline for an external capacitor when used. The internal connections of the relays are indicated in the table. Each relay contains a target seal-in unit that is used to protect the relay main contacts and control spring from damage due to breaker-trip current.

TABLE A

	CONTINUOUS RATING ** (VOLTS)	PICKUP RANGE, VOLTS	TAPS	CONTACTS	INTERNAL CONNECTIONS FIGURE
IAV51D	115	10-40	YES	1NO	1
	199	16-64			
	345	28-112			
IAV51K	67	5.4-20	YES	1NO	2
IAV52C	115	9.2	NO	2NO*	3
	199	16			
	345	28			
IAV52D	199	16-64	YES	2NO*	4
IAV52K	67	5.4-20	YES	2NO*	5

* The two normally-open contacts have a common connection; refer to the internal connections of the relay.

** All relays have a 360 volt 10 second rating.

APPLICATION

These are single-phase, sensitive, time-delay overvoltage relays. They are principally applicable for sensitive overvoltage ground detection for high-impedance grounded generators or for ungrounded power systems. These relays all have a capacitor in series with the operating coil. For the IAV51K and IAV52K relays, this capacitor is external to the relay because of its large size. The effect of the capacitor is to tune the relay coil circuit so that the relay pickup on third harmonic (180Hz) voltage is approximately eight times the relay pickup at 60 Hz. This is particularly important in overvoltage ground detection for generators, since they produce a large third-harmonic component of voltage during normal operation.

The external connection diagram for the IAV51K or the IAV52K relay for sensitive generator ground detection is shown in Fig. 8. This is a typical protection scheme for a unit generator transformer using a distribution transformer connected in the neutral with a resistor across the transformer secondary. The IAV51K/52K relays are usually used for this application because they provide the very sensitive 5.4 volt pickup rating. This enables the relay to detect a ground fault within a few percent of the winding from the neutral. Since the power transformer and the station service transformer in a unit generator transformer scheme are both connected in delta on the generator side, coordination with other protection is virtually unnecessary and the ground relay used can be very sensitive. Some time delay in relay operation is usually used to coordinate with fuses protecting against faults on the secondary side of potential transformers that are normally connected to the generator terminals. The usual practice is to use these relays to trip the generator breaker and shut down the machine. If the relay is used only to sound an alarm when a ground fault is detected, the application should be reviewed. It may be necessary to add another relay to provide ground protection with good sensitivity simultaneously with a high continuous-voltage rating.

The resistor, shown in Fig. 8 connected across the broken delta secondary of the PT's, or alternatively connected in series in the primary neutral connection, is usually required to prevent the occurrence of ferro-resonance. This phenomenon could occur due to the interaction of the PT inductance with the distributed capacitance-to-ground of the primary power system.

The external connection diagram for the IAV51D, 52D, or the IAV52C relay for ground-fault detection on an ungrounded power system is shown in Fig. 9. The relay operates to detect the first ground fault that occurs on the system, connections so that it can be removed before a second ground occurs, causing a double phase-to-ground fault, which requires a service interruption. Since the relay may be applied merely to sound an alarm in this application, it is necessary that it be continuously rated for the full broken-delta voltage expected for a single phase-to-ground fault located right at the potential transformers, or some automatic means must be employed to disconnect the relay from the voltage supply.

When this fault occurs it is equivalent to shorting out one phase of the potential transformer primary. The other two unfaulted phases of the PT primaries now have full phase-to-phase voltage applied and their corresponding

delta secondaries will be supplying $\sqrt{3}$ times their normal rated voltage. The broken delta equivalent voltage will be these two voltages added in series at a 60° angle and the broken delta voltage will therefore be three times the normal delta phase-to-phase voltage with no fault.

RATINGS

The operating-circuit ratings available are shown in Table I. The operating coil will stand rated voltage continuously on any tap.

TABLE I

RELAY	VOLTAGE RATINGS	
	60HZ	50HZ
IAV51D	115	115
	199	199
	345	345
1AV51K	67	67
1AV52C	115	115
	199	199
	345	345
1AV52D	199	
1AV52K	67	67

The current-closing rating of the contacts is 30 amperes for voltage not exceeding 250 volts. The current-carrying ratings are affected by the selection of the tap on the seal-in coil, as indicated in Table II.

TABLE II

Function	Amperes	
	2-Amp Tap	0.2-Amp Tap
Tripping Duty	30	3
Carry Continuously	3	0.3

The 2-ampere tap has a DC resistance of 0.13 ohms and a 60 cycle impedance of 0.53 ohms, while the 0.2-ampere tap has a 7-ohm DC resistance and a 52-ohm 60 cycle impedance. The tap setting used on the seal-in element is determined by the current drawn by the trip coil.

GEK-45404

The 0.2-ampere tap is for use with trip coils that operate on currents ranging from 0.2 up to 2.0 amperes at the minimum control voltage. If this tap is used with trip coils requiring more than two amperes, there is a possibility that the 7-ohm resistance will reduce the current to so low a value that the breaker will not be tripped.

The 2-ampere tap should be used with trip coils that take 2 amperes or more at minimum control voltage, provided the tripping current does not exceed 30 amperes at the maximum control voltage. If the tripping current exceeds 30 amperes an auxiliary relay should be used, the connections being such that the tripping current does not pass through the contacts of the target and seal-in coil of the protective relay.

BURDENS

Burdens for the various relay types are give in Tables IIIA and B.

TABLE IIIA

60 - Cycle Burdens at Rated Voltage					
RELAY TYPES	VOLTAGE RATING	TAP**SETTING	VOLT-AMPS	POWER FACTOR	WATTS
1AV51D	115	A(10)	31.4	0.33	10.2
		B(15)	27.2	0.57	15.6
		C(25)	19.0	0.82	15.6
		D(40)	12.3	0.93	11.4
IAV51D IAV52D	199	A(16)	32.0	0.31	9.9
		B(24)	27.9	0.56	15.6
		C(40)	20.0	0.81	16.2
		D(64)	13.2	0.92	12.2
IAV51D	345	A(28)	41.5	0.37	15.5
		B(42)	35.0	0.62	21.6
		C(70)	23.9	0.85	20.3
		D(112)	13.6	0.95	12.9
IAV51K IAV52K	67	A(5.4)	34.0	0.31	10.5
		B(7.5)	31.0	0.52	15.9
		C(12.5)	23.1	0.77	17.7
		D(20)	16.0	0.9	14.4
IAV52C	115	No Taps	24.2	0.21	5.0
	199	No Taps	32.0	0.31	9.9
	345	No Taps	41.5	0.37	15.5

**Minimum pickup volts

GEK-45404

TABLE IIIA (CONTINUED)

50 - Cycle Burdens at Rated Voltage					
RELAY TYPES	VOLTAGE RATING	TAP**SETTING	VOLT-AMPS	POWER FACTOR	WATTS
1AV51D	115	A(10)	36.8	0.34	12.6
		B(15)	30.8	0.62	19.0
		C(25)	20.3	0.86	17.4
		D(40)	12.7	0.95	12.0
IAV51D	199	A(16)	25.4	0.28	7.0
		B(24)	23.1	0.5	11.5
		C(40)	17.8	0.74	13.3
		D(64)	12.4	0.88	11.0
IAV51D	345	A(28)	31.9	0.36	11.4
		B(42)	28.3	0.56	15.8
		C(70)	21.0	0.79	16.6
		D(112)	12.8	0.93	11.9
IAV51K IAV52K	67	A(5.4)	28.8	0.29	8.4
		B(7.5)	26.6	0.45	12.1
		C(12.5)	21.1	0.71	14.9
		D(20)	16.0	0.86	13.7
IAV52C	115	No Taps	25.0	0.41	10.1
	199	No Taps	25.4	0.28	7.0
	345	No Taps	31.9	0.36	11.4

**Minimum pickup volts

TABLE IIIB

60 - Cycle Burdens at Tap					
RELAY TYPES	VOLTAGE RATING	TAP**SETTING	VOLT-AMPS	POWER FACTOR	WATTS
1AV51D	115	A(10)	0.46	0.99	0.46
		B(15)	0.62	1.0	0.62
		C(25)	0.96	1.0	0.96
		D(40)	1.48	1.0	1.48
IAV51D IAV52D	199	A(16)	0.41	0.94	0.38
		B(24)	0.56	0.98	0.55
		C(40)	0.89	0.99	0.88
		D(64)	1.38	1.0	1.37

GEK-45404

TABLE IIIB (CONTINUED)

IAV51D	345	A(28)	0.48	0.86	0.41
		B(42)	0.66	0.95	0.62
		C(70)	1.02	0.98	1.01
		D(112)	1.4	0.99	1.4
IAV51K IAV52K	67	A(5.4)	0.43	0.91	0.39
		B(7.5)	0.57	0.96	0.55
		C(12.5)	0.92	0.98	0.91
		D(20)	1.47	0.99	1.46
IAV52C	115	No Taps	0.36	0.78	0.28
	199	No Taps	0.41	0.94	0.38
	345	No Taps	0.48	0.86	0.41

**Minimum pickup volts

TABLE IIIB

50 - Cycle Burdens at Tap					
RELAY TYPES	VOLTAGE RATING	TAP**SETTING	VOLT-AMPS	POWER FACTOR	WATTS
IAV51D	115	A(10)	0.52	0.98	0.52
		B(15)	0.67	0.99	0.67
		C(25)	1.0	1.0	1.0
		D(40)	1.52	1.0	1.52
IAV51D	199	A(16)	0.32	0.85	0.27
		B(24)	0.5	0.93	0.46
		C(40)	0.83	0.97	0.81
		D(64)	1.33	0.99	1.32
IAV51D	345	A(28)	0.39	0.96	0.37
		B(42)	0.58	0.98	0.57
		C(70)	0.96	0.99	0.95
		D(112)	1.35	1.0	1.35
IAV51K IAV52K	67	A(5.4)	0.38	0.91	0.34
		B(7.5)	0.52	0.95	0.5
		C(12.5)	0.87	0.98	0.85
		D(20)	1.42	0.99	1.41
IAV52C	115	No Taps	0.27	0.98	0.27
	199	No Taps	0.32	0.85	0.27
	345	No Taps	0.39	0.96	0.37

**Minimum pickup volts

OPERATING CHARACTERISTICS

The Type IAV51D relay is a low-pickup voltage relay normally used for ground fault protection on AC rotating machines. It has single-circuit closing contacts that close when the voltage increases to pickup value, as set on the tap block. The time delay in closing the contacts is determined by the setting of the time dial at the top of the shaft. The IAV51D has a capacitor and tapped resistor connected in series with the operating coil. The capacitor is added to tune the circuit, giving a low pickup voltage at rated frequency. At rated voltage the operating U magnet is highly saturated, increasing the impedance of the circuit, thus limiting the current to a safe value. The taps on the resistor are connected to the tap block to provide a four-to-one range of pickup. As shown in the typical external connection diagram, Fig. 8, this relay is connected to the machine neutral potential transformer through a closed contact on the auxiliary tripping relay, hence is energized only when a ground occurs. To obtain still-lower pickup than the normal calibration, it is permissible to insert an inverted potential transformer between the machine neutral transformer and the relay coil circuit. The IAV51D has a seal-in element. Time curves are shown in Fig. 11.

The IAV51K relay is similar to the IAV51D except that it has an external capacitor. Time curves are shown in Fig. 11.

The IAV52K relay is similar to the IAV51K except that it has two, instead of one, normally-open contacts.

The IAV52C is a low-pickup, time-overvoltage relay with two normally-open contacts. It has a seal-in element. It has a capacitor connected in series with the operating coil but, unlike the IAV51D relay, it does not have a tapped resistor connected in series with the operating coil. The time-voltage characteristics at the #1, #5, and #10 time-dial settings are the same as for the "A" taps of the IAV51/52D and K relays shown in Fig. 11.

CONSTRUCTION

These relays are the induction disk construction. The disk is actuated by a potential operating coil on a laminated U-magnet. The disk shaft carries the moving contact, which completes the trip or alarm circuit when it touches the stationary contact or contacts. The disk shaft is restrained by a spiral spring to give the proper contact-closing voltage, and its motion is retarded by permanent magnets acting on the disk to give the correct time delay.

There is a seal-in unit mounted to the left of the shaft. This unit has its coil in series and its contacts in parallel with the main contacts, such that when the main contacts close, the seal-in unit picks up and seals in. When the seal-in unit picks up, it raises a target into view that latches up and remains exposed until released by pressing a button beneath the lower-left corner of the cover.

The case is suitable for either surface or semi-flush panel mounting and an assortment of hardware is provided for either mounting. The cover attaches to the case and also carries the reset mechanism when one is required. Two of the cover screws have provision for a sealing wire.

The case has studs or screw connections at the bottom for the external connections. The electrical connections between the relay units and the case studs are made through spring-backed contact fingers mounted in stationary, molded inner and outer blocks, between which nests a removable connecting plug that completes the circuits. The outer blocks, attached to the case, have the studs for the external connections, and the inner blocks have the terminals for the internal connections.

The relay mechanism is mounted in a steel framework called the cradle and is a complete unit, with all leads being terminated at the inner block. This cradle is held firmly in the case by a latch at the top and the bottom and by a guide pin at the back of the case. The case and cradles are so constructed that the relay cannot be inserted in the case upside down. The connecting plug, besides making the electrical connections between the respective blocks of the cradle and case, also locks the latch in place. The cover, which is fastened to the case by thumbscrews, holds the connecting plug in place.

To draw out the cradle from a single-ended case, the cover must first be removed. Then the connecting plug can be drawn out. In so doing, the trip circuit is the first one opened, then the voltage circuits are opened. After the connecting plug has been removed, the lower latch can be released and the cradle easily drawn out. To replace the cradle, the reverse order should be followed. The internal connections of the relays are shown in Figs. 3, 4, 5, 6, and 7.

RECEIVING, HANDLING, AND STORAGE

RECEIVING

These relays, when not shipped as a part of a control panel, will be shipped in cartons designed to protect them against damage. Immediately upon receipt of the relay, an examination should be made for any damage sustained during shipment. If injury or damage resulting from rough handling is evident, a damage claim should be filed at once with the transportation company and the nearest General Electric Sales Office should be notified promptly.

HANDLING

Reasonable care should be exercised in unpacking the relay in order that none of the parts are injured nor the adjustments disturbed.

STORAGE

If the relays are not to be installed immediately, they should be stored in their original cartons in a place that is free from moisture, dust, and metallic chips. Foreign matter collected on the outside of the case may find its way inside when the cover is removed and cause trouble in the operation of the relay.

ACCEPTANCE TESTS

Immediately upon receipt of the relay an inspection and acceptance test should be made to make sure that no damage has been sustained in shipment and that the relay calibrations have not been disturbed.

VISUAL INSPECTION

Check the nameplate stamping to make sure that the model number and rating of the relay agree with the requisition.

Remove the relay from its case and check that there are no broken or cracked molded parts or other signs of physical damage, and that all screws are tight.

CAUTION:

Every circuit in the drawout case has an auxiliary brush. It is especially important on current circuits and other circuits with shorting bars that the auxiliary brush be bent high enough to engage the connecting plug or test plug before the main brushes do. This will prevent Current Transformer (CT) secondary circuits from being opened.

MECHANICAL INSPECTION

On relays that have time dials, the dials will be set at zero before the relay leaves the factory. It is necessary to change this setting to open the relay contacts.

On all relays with locked time dials, make sure the two time-dial locking screws are tight. These locking screws are to prevent the dial from moving when the relay is subjected to high operating torque.

The moving contact should be fastened securely in its support, and should engage the stationary contact about in the middle, or at least 1/16 inch inside the periphery of the stationary contact.

The stop-arm leaf spring should deflect about 1/64 inch and the stop arm should clear the molded block by at least 0.020 inch.

Any foreign material must be cleaned out of stator air gaps. Clearance between the disk and either the drag magnet or U magnet should be at least 0.010 inch for any position of the disk.

End play of the disk should be from 0.005 inch to 0.010 inch. End play should not be so great as to allow the disk to strike the U magnet or the drag magnet. Check that top and bottom pivot and bearing screws are tight.

There should be no noticeable friction in the rotating structure.

Rotate the time dial to the zero position. Check by means of a neon lamp that the contacts just close; there should be approximately 1/32 inch wipe on the stationary contact. If the contact does not close, adjust the disk position by backing off the two clamping screws on the stop arm and rotating the stop arm relative to the cutout in the disk. This is a coarse adjustment. Retighten the clamping screws.

For fine adjustment of contact closing, run the stationary contact brush in or out by means of its adjusting screw; after this adjustment, check that the screw is held firmly in its support.

ELECTRICAL TESTS

Drawout Relays - General

Since all drawout relays in service operate in their cases, it is recommended that they be tested in their cases or an equivalent steel case. In this way any magnetic effects of the enclosure will be accurately duplicated during testing. A relay may be tested without removing it from the panel by using a 12XLA13A test plug. This plug makes connections only with the relay and does not disturb any shorting bars in the case. Of course, the 12XLA12A test plug may also be used. Although this test plug allows greater testing flexibility, it also requires CT shorting jumpers and the exercise of greater care since connections are made to both the relay and the external circuitry.

Power Requirements - General

All alternating-current-operated devices are affected by frequency. Since non-sinusoidal waveforms can be analyzed as a fundamental frequency plus harmonics of the fundamental frequency, it follows that alternating-current devices (relays) will be affected by the applied waveform.

Therefore, in order to test alternating-current relays properly it is essential to use a sine wave of current and/or voltage. The purity of the sine wave (i.e. its freedom from harmonics) cannot be expressed as a finite number for any particular relay; however, and relay using tuned circuits, RL or RC networks, or saturating electromagnets (such as time-overcurrent relays) would be especially affected by non-sinusoidal waveforms.

Similarly, relays requiring DC control power should be tested using direct current and not full-wave rectified power. Unless the rectified supply is well filtered, many relays will not operate properly due to the dips in the rectified power. Zener diodes, for example, can turn off during these dips. As a general rule the DC source should not contain more than 5% ripple.

Pickup-voltage Test

The pickup voltage should be checked; for the IAV51D, IAV51K, and IAV52K, the pickup voltage should be checked on more than one tap. See relay nameplate for value of pickup voltage (closing volts). Test connections, Fig. 10, are the same as for the time-voltage test except that the timer is not required.

Time-voltage Test

The time-voltage curves should be checked for one or more settings. Recommended test connections for this test are shown in Fig. 10.

INSTALLATION

INSPECTION

At the time of installation, the relay should be inspected for tarnished contacts, loose screws, or other imperfections. If any trouble is found, it

should be corrected; see **MAINTENANCE**. Check the nameplate for model number and rating.

LOCATION

The location should be clean and dry, free from dust and excessive vibration, and well lighted to facilitate inspection and testing.

MOUNTING

The relay should be mounted on a vertical surface. The outline and panel drilling dimensions are shown in Fig. 14 for relay Types IAV51D, IAV52D, and IAV52C. Fig. 15 shows outline and panel drilling for relay Types IAV51K and IAV52K.

CONNECTIONS

Internal connections are shown in Figs. 3 to 7 for the various relays.

GROUND CONNECTIONS

One of the mounting studs or screws should be permanently grounded by a conductor not less than No. 12 B&S gage copper wire or its equivalent.

OPERATION

Before the relay is put in service, the pickup-voltage and time-voltage tests described under **ACCEPTANCE TESTS (ELECTRICAL TESTS)** should be made to determine that factory adjustments have not been disturbed.

The relay may be tested while mounted on the panel, either from its own or another source of power, by inserting a separate testing plug in place of the connecting plug. Or, the cradle can be drawn out and replaced by another that has been laboratory tested.

ADJUSTMENTS

Target and Seal-in Unit

For trip coils operating on current ranging from 0.2 up to 2.0 amperes at the minimum control voltage, set the target and seal-in tap plug in the 0.2-ampere tap.

For trip coils operating on currents ranging from 2 to 30 amperes at the minimum control voltage, place the tap plug in the 2.0-ampere tap.

The tap plug is the screw holding the right-hand stationary contact of the seal-in element. To change the tap setting, first remove the connecting plug. Then, take a screw from the left-hand stationary contact and place it in the desired tap. Next, remove the screw from the other tap, and place it in the left-hand contact. This procedure is necessary to prevent the right-hand stationary contact from getting out of adjustment. Screws should **not** be in **both** taps at the same time, as pickup for DC will be the higher tap value and AC pickup will be increased.

Voltage Setting

The voltage at which the contacts operate may be changed by changing the tap of the IAV51D, IAV52D, and IAV51K relays.

The pickup of any of the relays, when set for minimum pickup, can be adjusted by means of the spring adjusting ring. The ring may be turned by inserting a tool in the notches around the edge. By turning the ring, the operating voltage of the IAV52C relay may be brought into agreement with the nameplate value, and in the same way the IAV51D, IAV51K, and IAV52K relays may be brought into agreement with the minimum tap setting.

For taps other than minimum, the slide band on the adjustable resistor associated with the selected tap, in series with the operating coil, should be moved until the pickup is at tap voltage. This adjustment should not be made until the spring adjustment for minimum pickup is made, since the spring adjustment sets the basic torque level of the relay.

Adjustments for pickup between calibrated taps can be made by selecting the tap closest to the desired voltage and then adjusting the resistor band associated with the tap selected.

The relay is adjusted at the factory to operate from any time-dial position at a minimum voltage that is 8% of rated voltage. The relays reset at 90% or more of the operating value. Operating voltage for the IAV51D, IAV52D, IAV51K, and IAV52K relays is the minimum voltage for a given tap setting at which the contacts just make.

Time Setting

The time of operation of the overvoltage relay is determined primarily by the setting of the time dial. Further adjustment is obtained by moving the permanent magnet along its supporting shelf; moving the magnet in toward the back of the relay decreases the time, while moving it out increases the time.

Fig. 11 shows the time-voltage characteristics of the IAV51D, IAV52D, IAV51K and IAV52K for the four tap settings for the Number 1, 5, and 10 time-dial positions. The time-voltage characteristic of the IAV52C, which has no taps, is the same as for the "A" tap in the D & K relays.

To make time settings, set the time dial to the number required (to give the desired characteristic) by turning it until the number lines up with the notch in the adjacent frame. The time indicated by the curves is the time required to close the relay contacts when the voltage is suddenly increased from a value below pickup to the value on the curve (expressed in multiples of tap setting). The time obtained should be the value on the curve $\pm 15\%$.

PERIODIC CHECKS AND ROUTINE MAINTENANCE

In view of the vital role of protective relays in the operation of a power system, it is important that a periodic test program be followed. It is recognized that the interval between periodic checks will vary depending upon environment, type of relay and the user's experience with periodic testing. Until the user has accumulated enough experience to select the test interval best suited to his individual requirements, it is suggested that the points listed under INSTALLATION PROCEDURE be checked every six months.

MAINTENANCE

These relays are adjusted at the factory and it is advisable not to disturb the adjustments. If for any reason, they have been disturbed, the following points should be observed in restoring them.

DISK AND BEARINGS

The lower jewel may be tested for cracks by exploring its surface with the point of a fine needle. If it is necessary to replace the jewel, the new jewel should be turned up until the disk is centered in the air gap, after which it should be locked in position by the set screw provided for the purpose.

CONTACT CLEANING

For cleaning fine silver contacts, a flexible burnishing tool should be used. This consists of a flexible strip of metal with an etched roughened surface, resembling in effect a superfine file. The polishing action is so delicate that no scratches are left, yet corroded material will be removed rapidly and thoroughly. The flexibility of the tool ensures the cleaning of the actual points of contact.

Fine silver contacts should not be cleaned with knives, files, or abrasive paper or cloth. Knives or files may leave scratches, which increase caring and deterioration of the contacts. Abrasive paper or cloth may leave minute particles of insulating abrasive material in the contacts and thus prevent closing.

The burnishing tool described above can be obtained from the factory.

SERVICING

For servicing and adjustments see applicable instructions under **ACCEPTANCE TESTS, INSTALLATION, AND MAINTENANCE.**

RENEWAL PARTS

It is recommended that sufficient quantities of renewal parts be carried in stock to enable the prompt replacement of any that are worn, broken, or damaged. Parts bulletin number GEF-3897 gives a list of those most subject to wear in ordinary operation, or to damage due to possible abnormal conditions.

When ordering renewal parts, address the nearest Sales Office of the General Electric Company, specify quantity required, and give name of part wanted, complete nameplate data, including serial number. If possible give the General Electric Company's requisition on which the relay was furnished.

Since the last edition, a change has been made in the APPLICATION section, at to top of page 5.

GEK-45404

LIST OF ILLUSTRATIONS

FIG. 1	(8043181-0)	TYPE IAV51D RELAY, REMOVED FROM CASE, FRONT VIEW
FIG. 2	(8043182-0)	TYPE IAV51D RELAY, REMOVED FROM CASE, REAR VIEW
FIG. 3	(K-6400439-5)	INTERNAL CONNECTIONS OF THE TYPE IAV51D RELAY, FRONT VIEW
FIG. 4	(362A514-3)	INTERNAL CONNECTIONS OF THE TYPE IAV51K RELAY, FRONT VIEW
FIG. 5	(K-6556505-0)	INTERNAL CONNECTIONS OF THE TYPE IAV52C RELAY, FRONT VIEW
FIG. 6	(418A790-0)	INTERNAL CONNECTIONS OF THE TYPE IAV52D RELAY, FRONT VIEW
FIG. 7	(0257A8379-0)	INTERNAL CONNECTIONS OF THE TYPE IAV52K RELAY, FRONT VIEW
FIG. 8	(0275A2004-0)	EXTERNAL CONNECTION DIAGRAM OF TYPES IAV51K AND IAV52K FOR GENERATOR GROUND-FAULT PROTECTION
Fig. 9	(0275A2003-0)	EXTERNAL CONNECTION DIAGRAM OF TYPE IAV51D AND IAV52C FOR GROUND-FAULT DETECTION ON AN UNGROUNDED SYSTEM
FIG. 10	(K6154391-3)	TEST CONNECTIONS FOR OVERVOLTAGE RELAYS
FIG. 11	(0178A8140-0)	TIME VOLTAGE CURVES FOR TYPES IAV51D, 51K, 52D, AND 52K RELAYS
FIG. 12	(8025039-0)	CROSS SECTION OF DRAWOUT CASE SHOWING POSITION OF AUXILIARY BRUSH
FIG. 13	(0275A4399-0)	OUTLINE OF IAV51K AND IAV52K EXTERNAL CAPACITOR
FIG. 14	(K6209270-2)	OUTLINE AND PANEL DRILLING FOR RELAY TYPES IAV51D, 52D AND IAV52C
FIG. 15	(K6209271-7)	OUTLINE AND PANEL DRILLING FOR RELAY TYPES IAV51K AND IAV52K

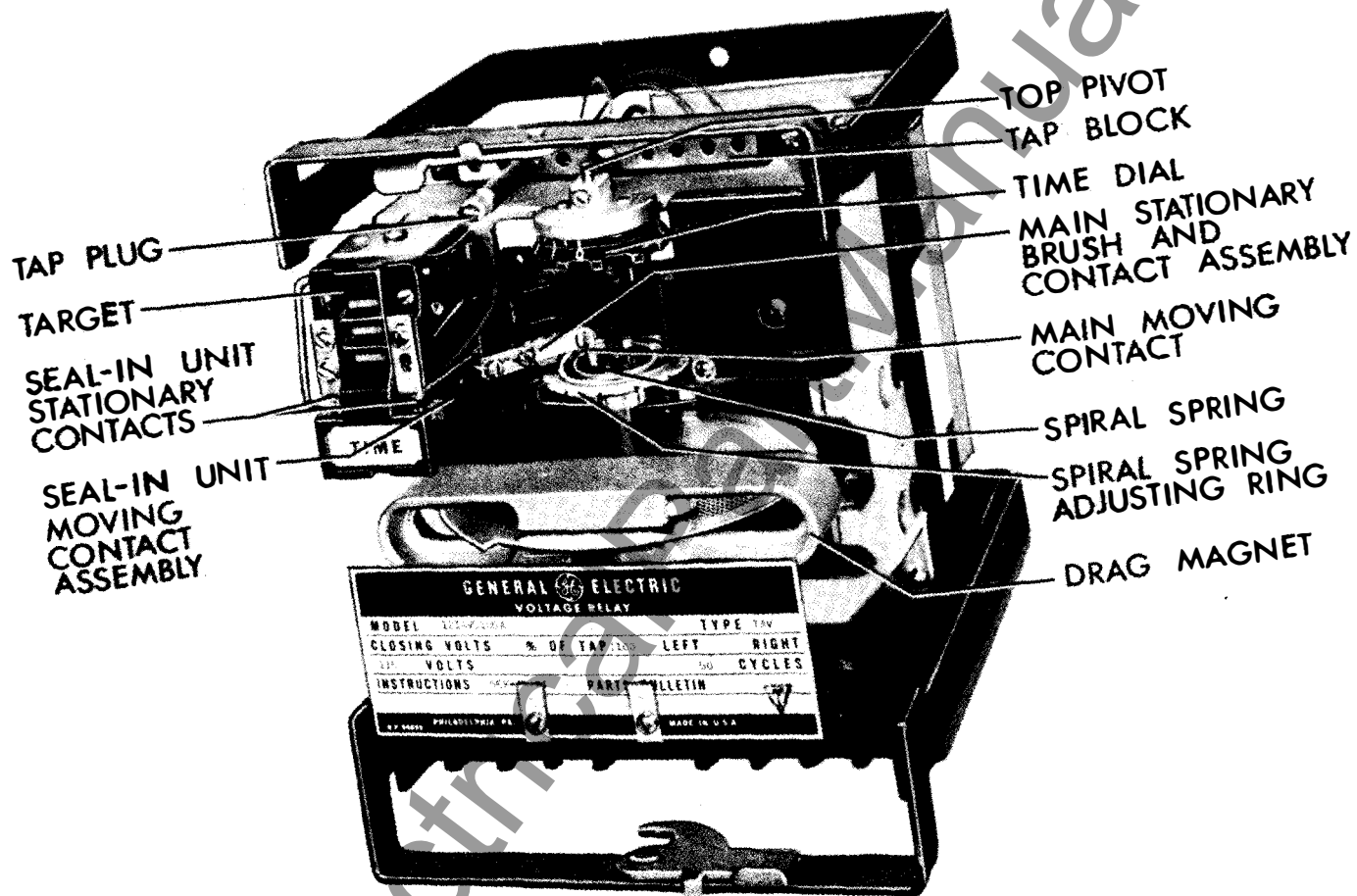

FIG. 1 (8043181-0) TYPE IAV51D RELAY, REMOVED FROM CASE, FRONT VIEW

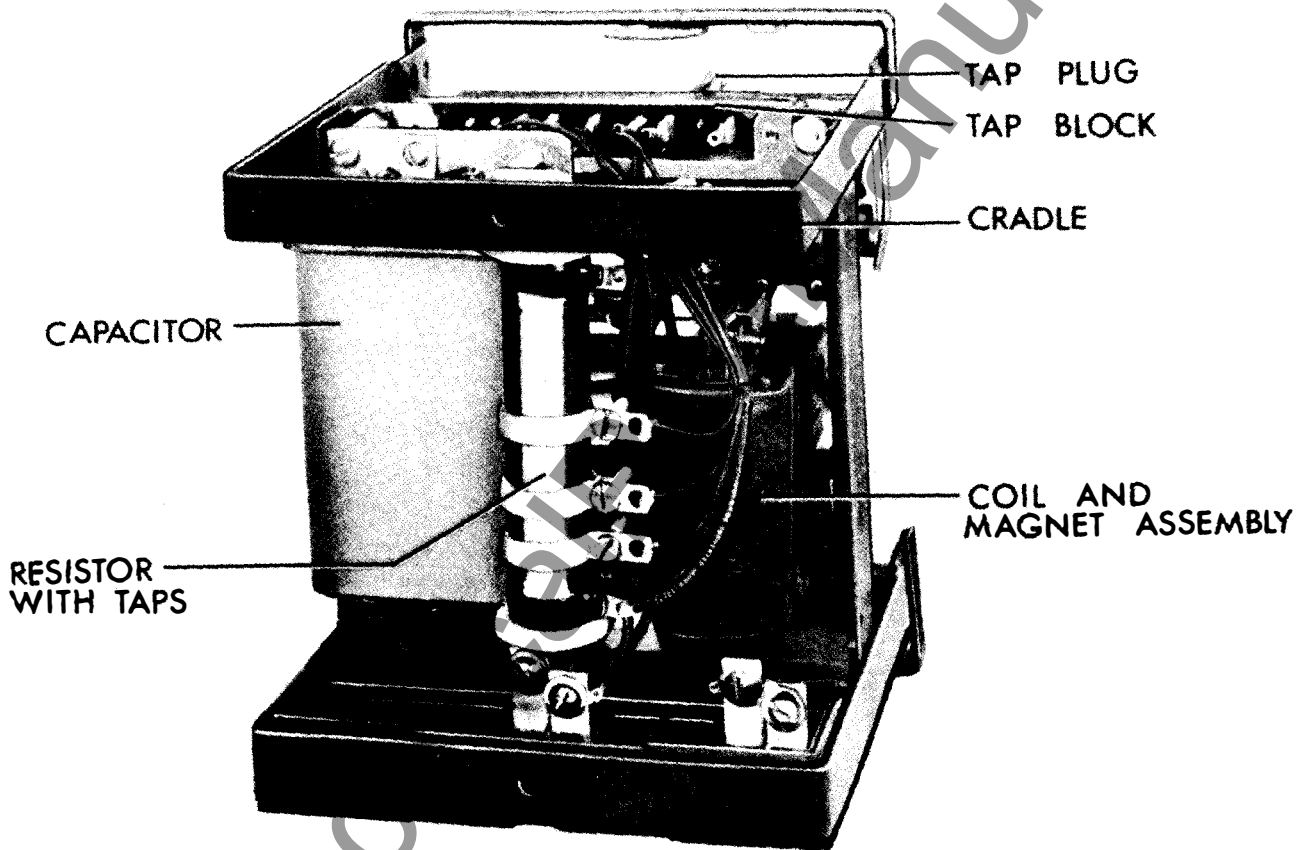

FIG. 2 (8043182-0) TYPE IAV51D RELAY, REMOVED FROM CASE, REAR VIEW

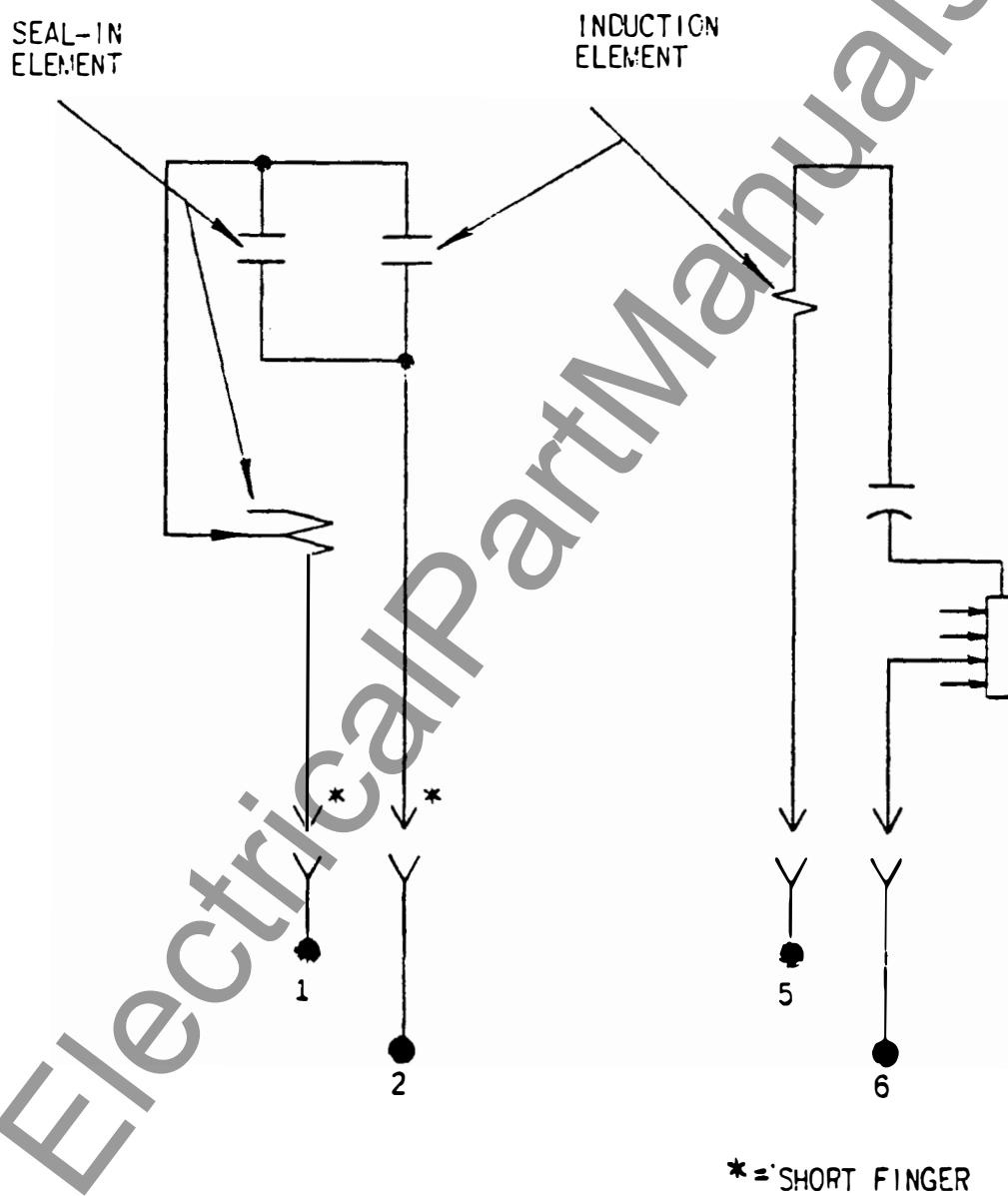

FIG. 3 (K-6400439-5) INTERNAL CONNECTIONS OF THE TYPE IAV51D RELAY, FRONT VIEW

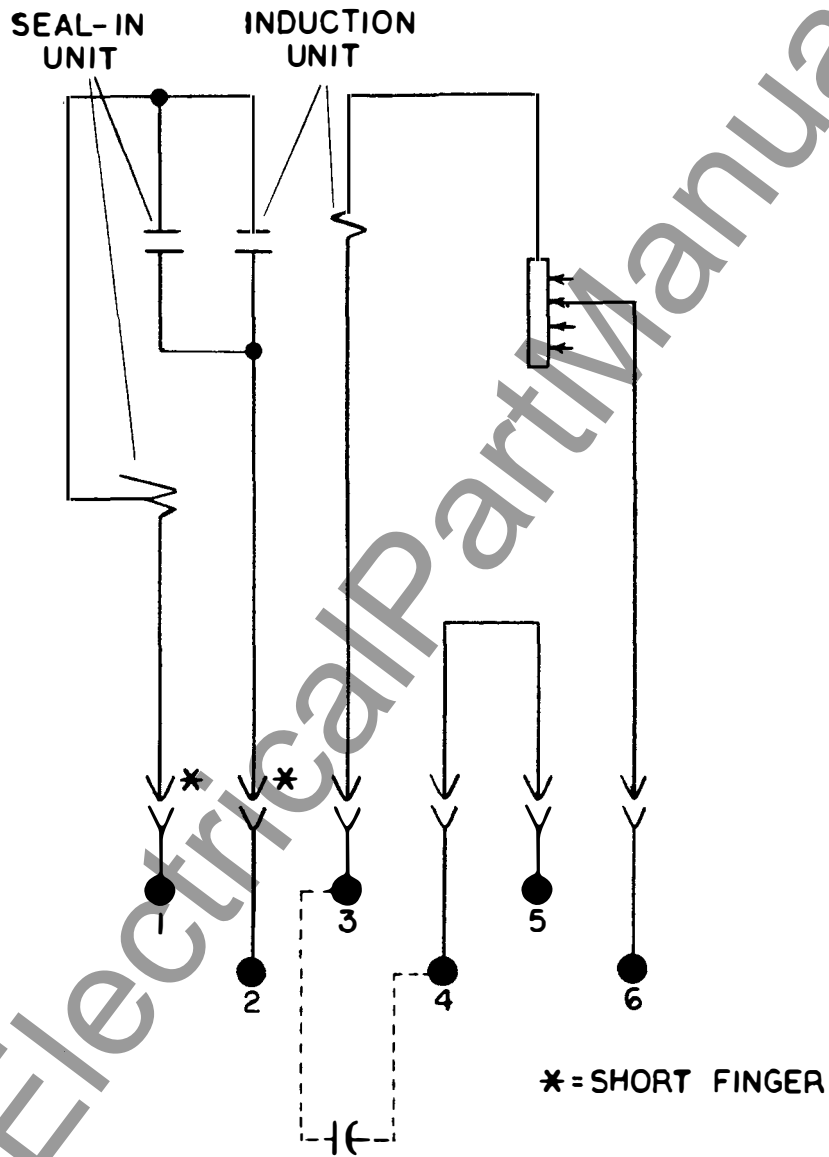

FIG. 4 (362A514-3) INTERNAL CONNECTIONS OF THE TYPE IAV51K RELAY, FRONT VIEW

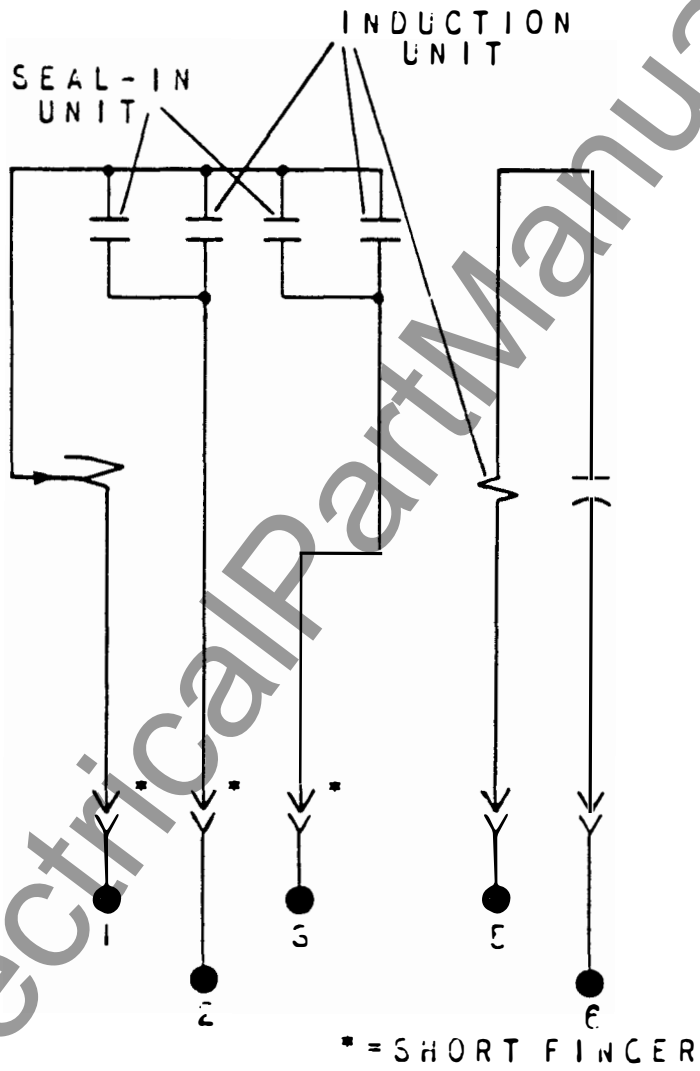
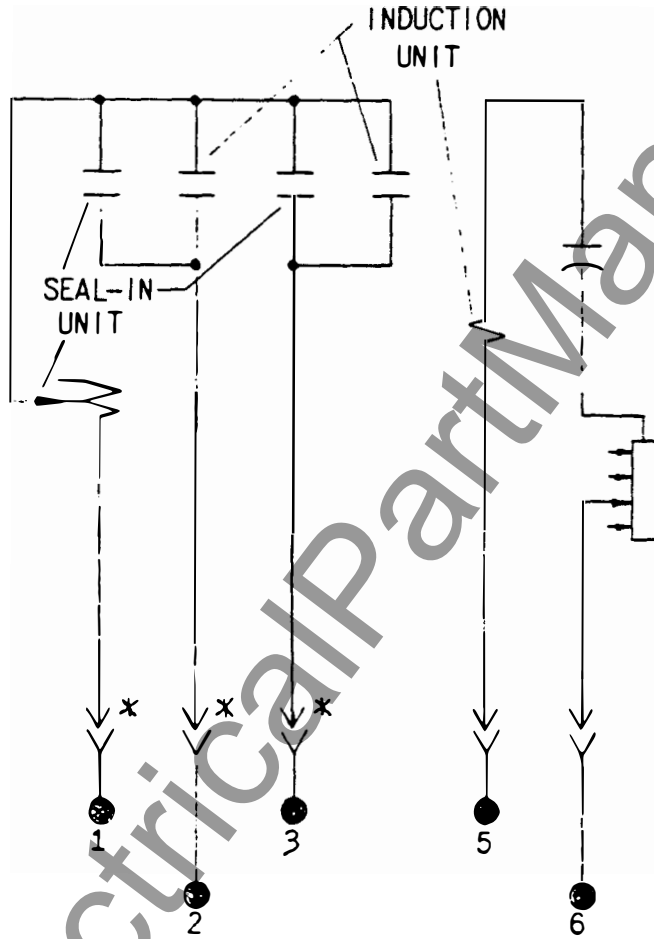
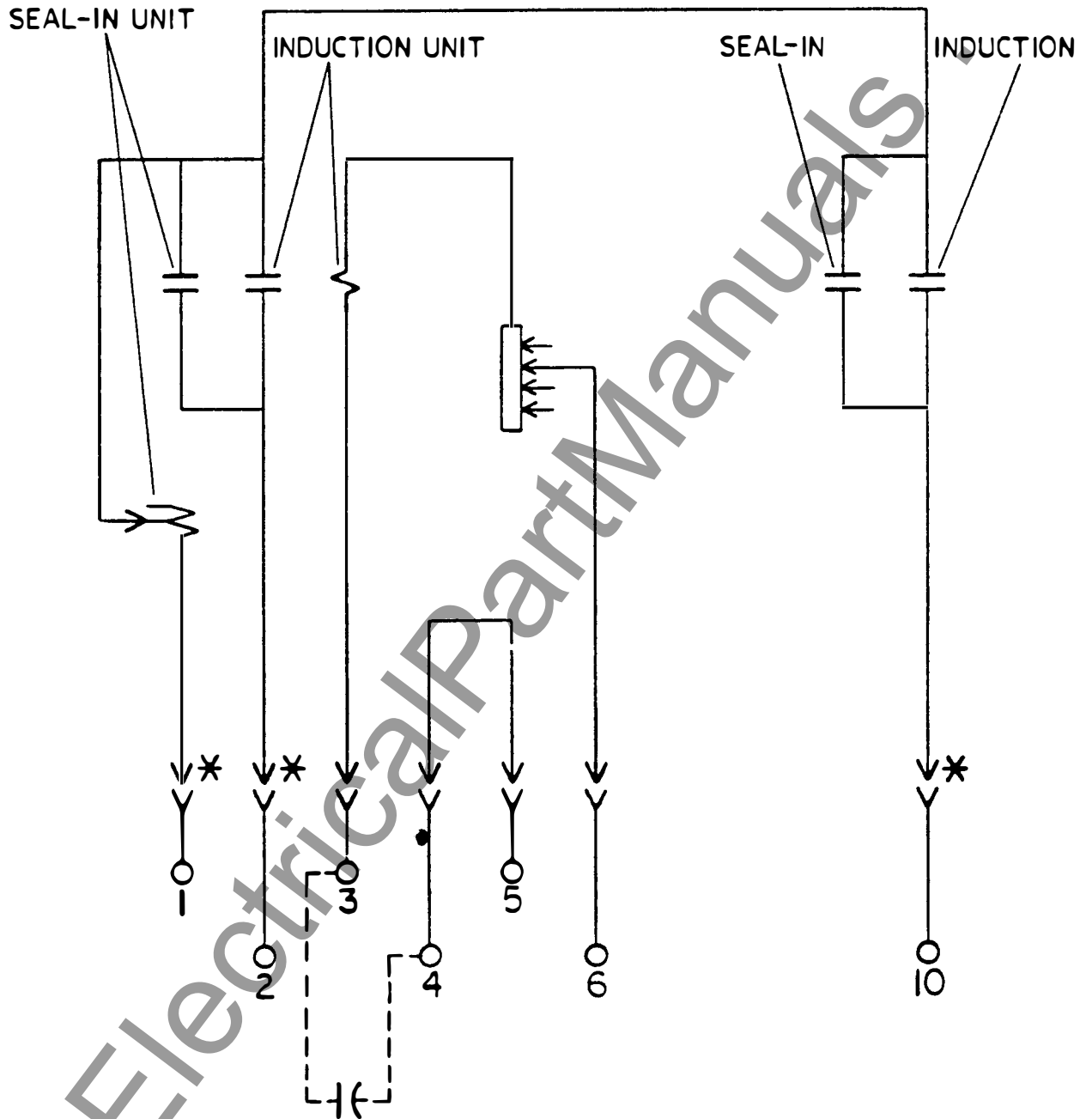

FIG. 5 (K-6556505-0) INTERNAL CONNECTIONS OF THE TYPE IAV52C RELAY, FRONT VIEW



* = SHORT FINGER

FIG. 6 (418A790-0) INTERNAL CONNECTIONS OF THE TYPE IAV52D RELAY, FRONT VIEW



* = SHORT FINGER

FIG. 7 (0257A8379-0) INTERNAL CONNECTIONS OF THE TYPE IAV52K RELAY, FRONT VIEW

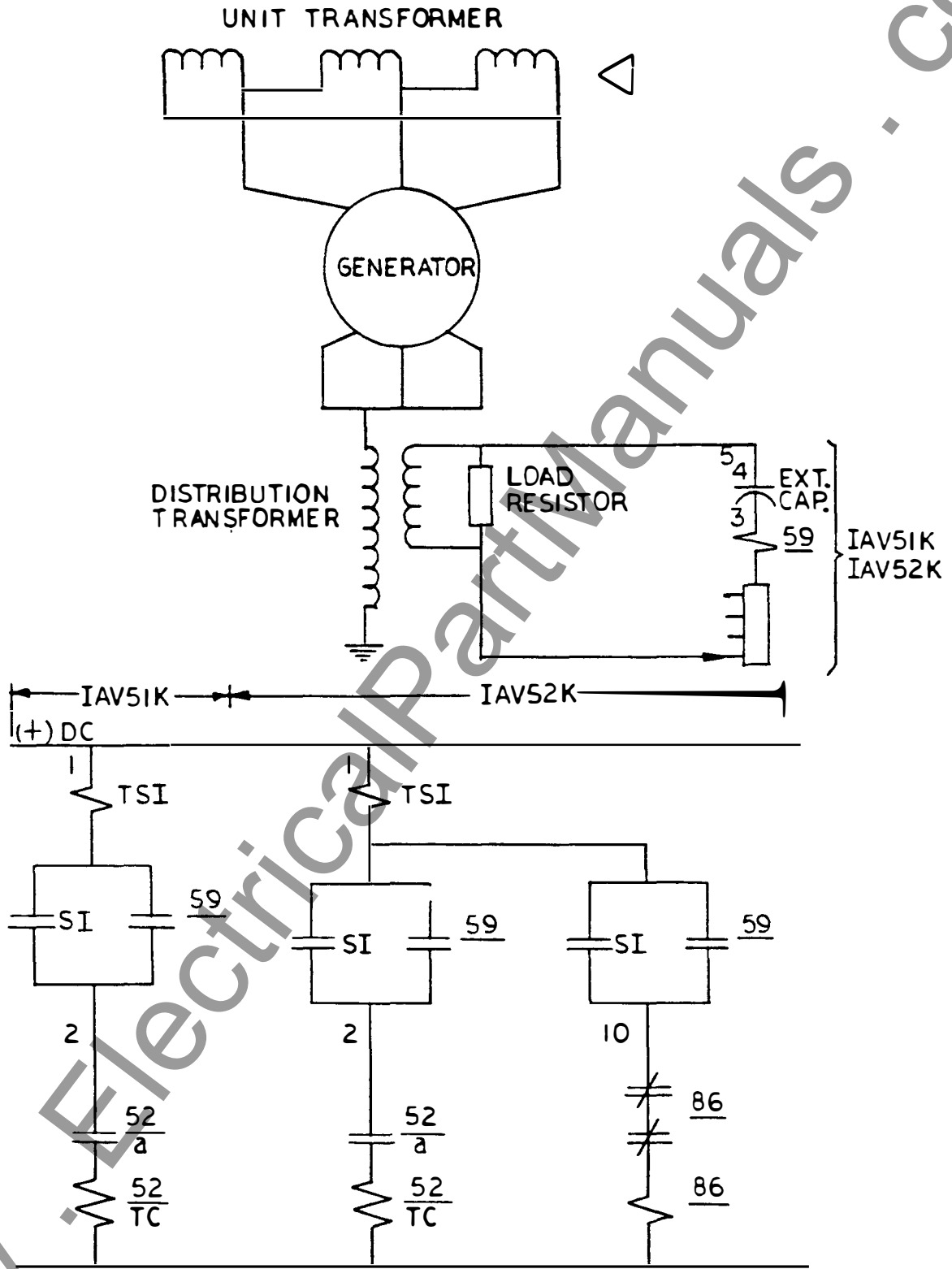

FIG. 8 (0275A2004-0) EXTERNAL CONNECTION DIAGRAM OF TYPES IAV51K AND IAV52K FOR GENERATOR GROUND-FAULT PROTECTION

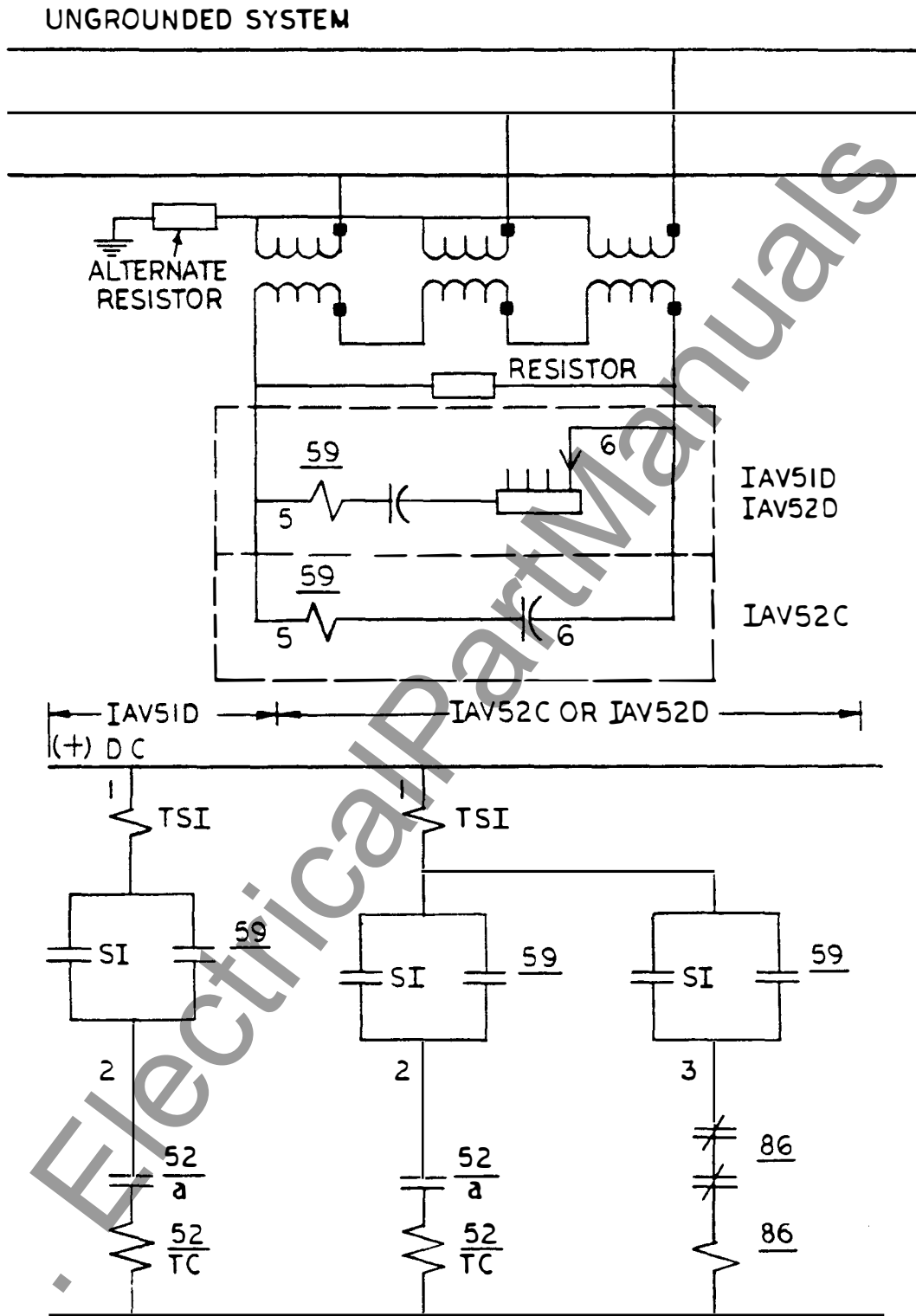
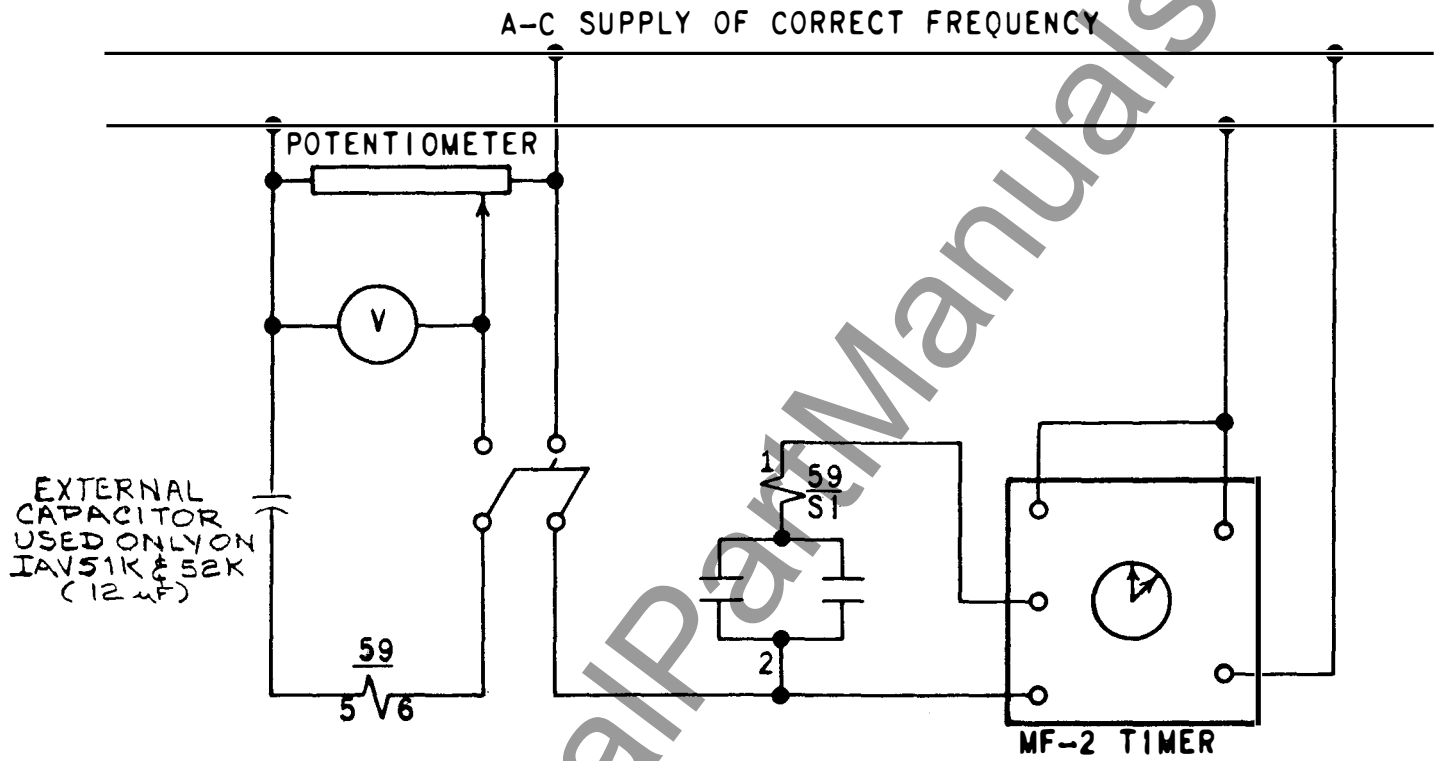

FIG. 9 (0275A2003-0) EXTERNAL CONNECTION DIAGRAM OF TYPE IAV51D, IAV52C AND IAV52D FOR GROUND-FAULT DETECTION ON AN UNGROUNDED SYSTEM



DEVICE FUNCTION NUMBERS

59 - OVERVOLTAGE RELAY TYPE IAV

S1 - SEAL-IN UNIT WITH TARGET

FIG. 10 (K6154391-3) TEST CONNECTIONS FOR OVERVOLTAGE RELAYS

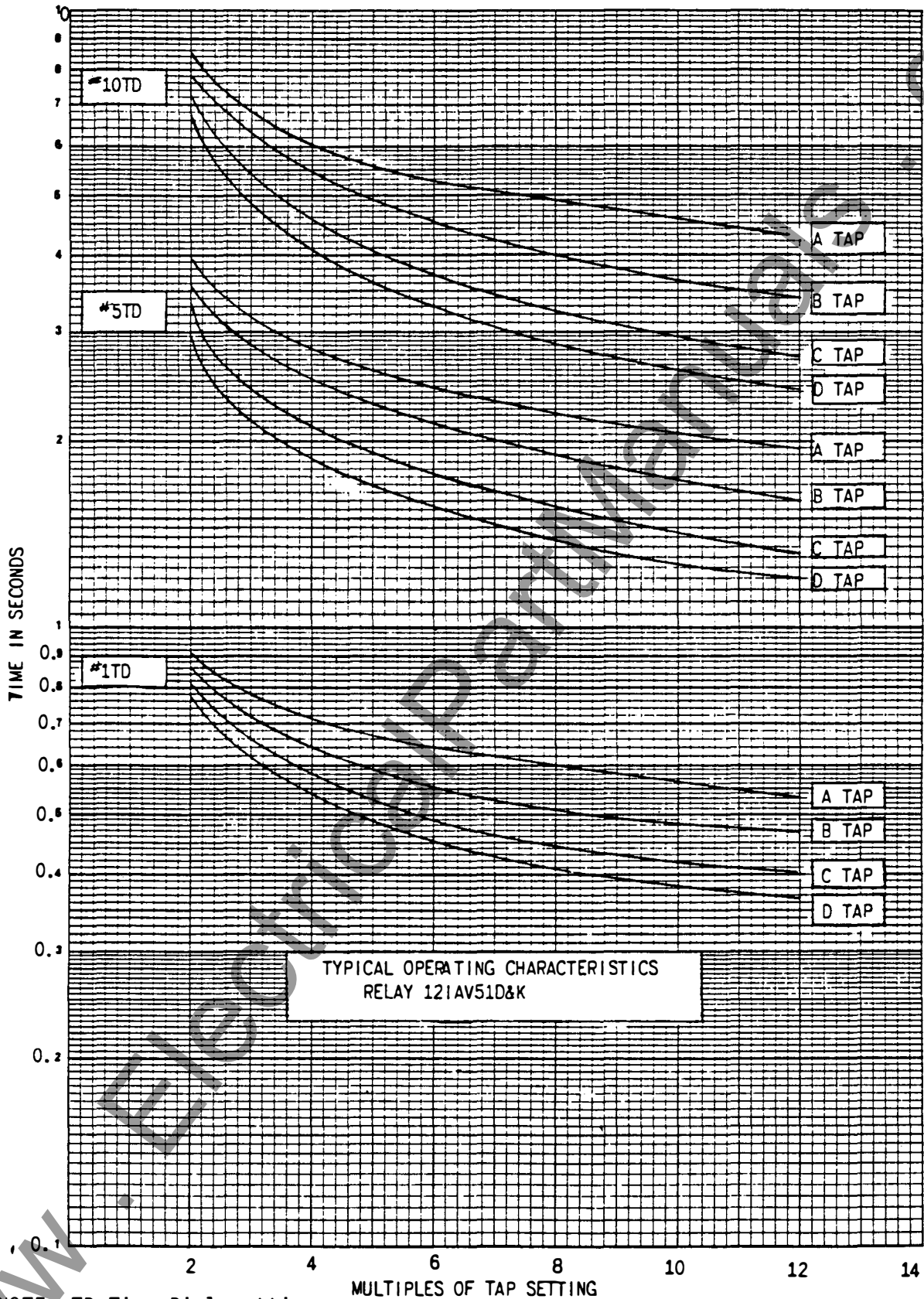

NOTE: TD=Time Dial setting

FIG. 11 (0178A8140-0) TIME VOLTAGE CURVES FOR TYPES IAV51D, 51K, 52D, AND 52K RELAYS

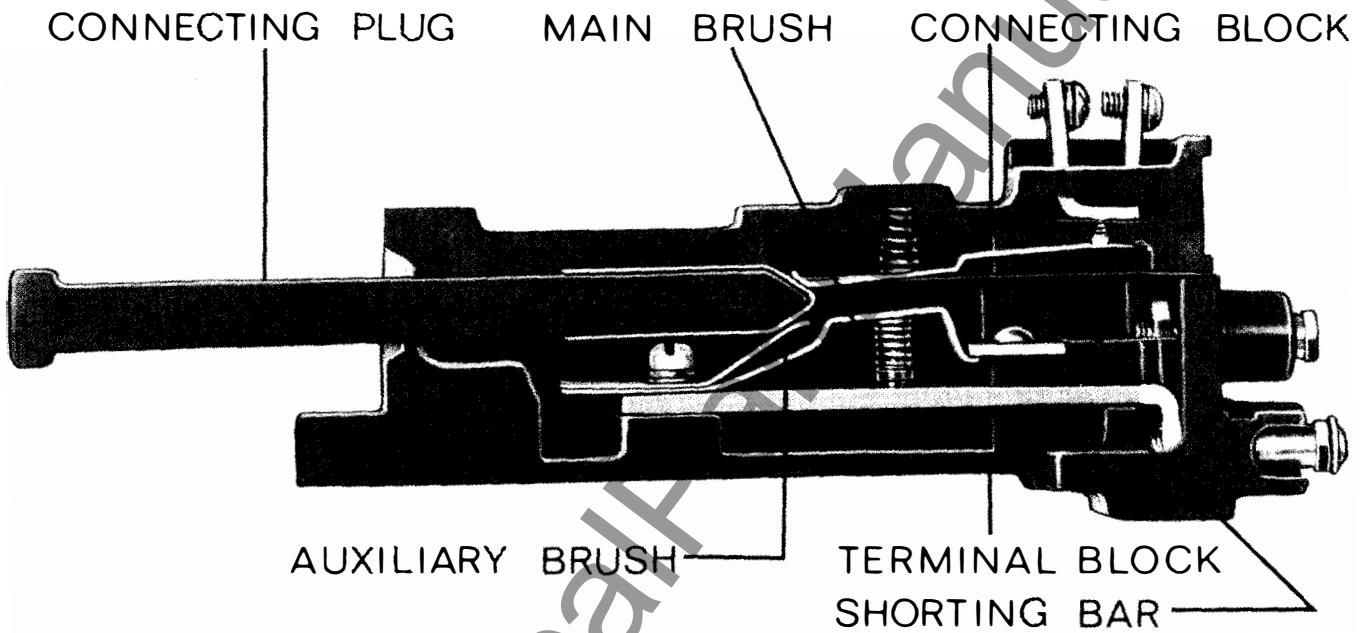

NOTE: AFTER ENGAGING AUXILIARY BRUSH CONNECTING PLUG TRAVELS $\frac{1}{4}$ INCH BEFORE ENGAGING THE MAIN BRUSH ON THE TERMINAL BLOCK

FIG. 12 (8025039-0) CROSS SECTION OF DRAWOUT CASE SHOWING POSITION OF AUXILIARY BRUSH

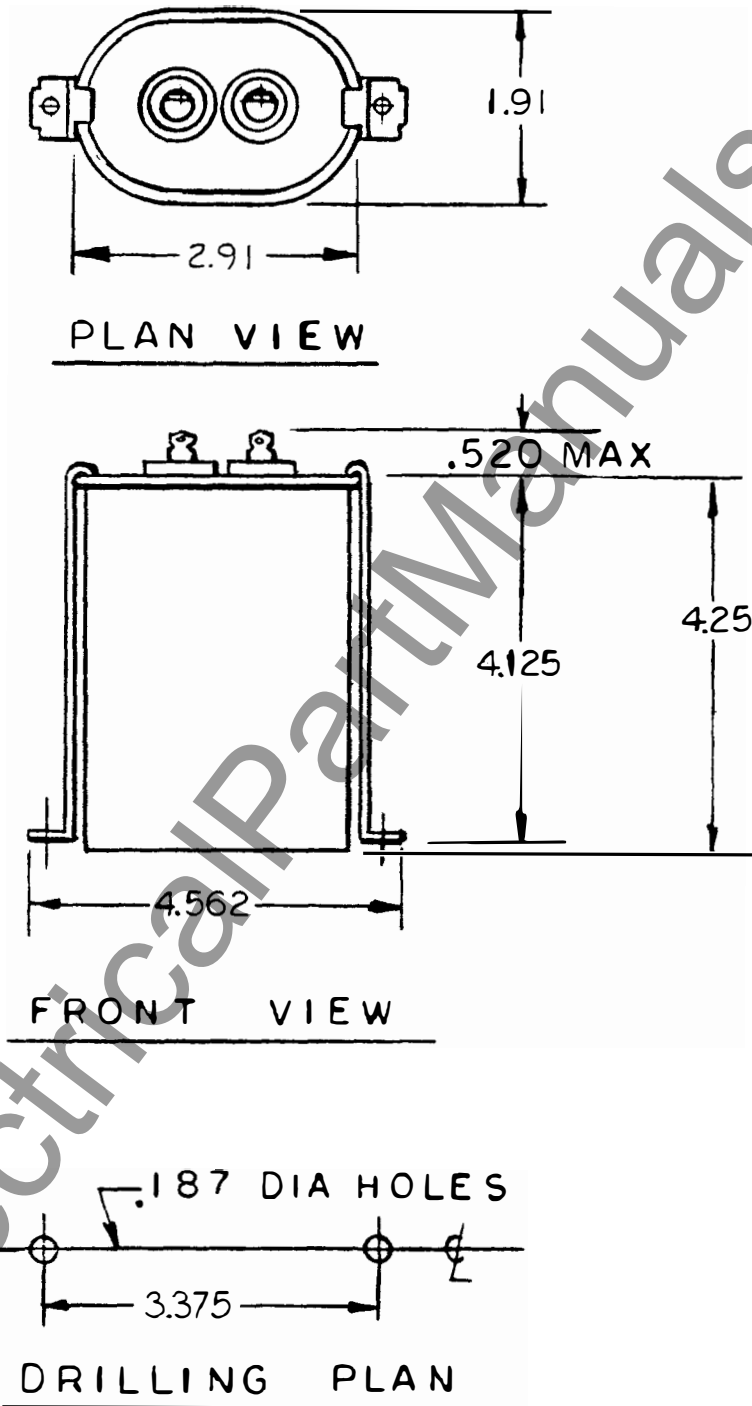

CAPACITOR 0246A9024 P1200A
BRACKET 0302C0920 P122

FIG. 13 (0275A4399-1) OUTLINE OF IAV51K AND IAV52K EXTERNAL CAPACITOR

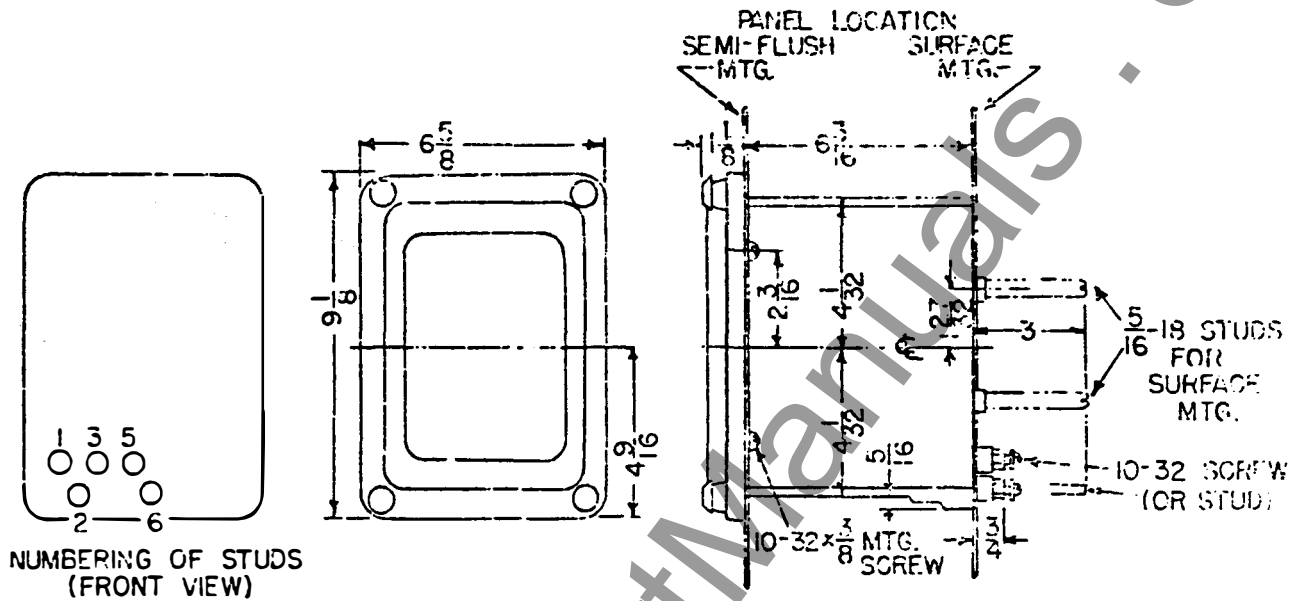

OUTLINE

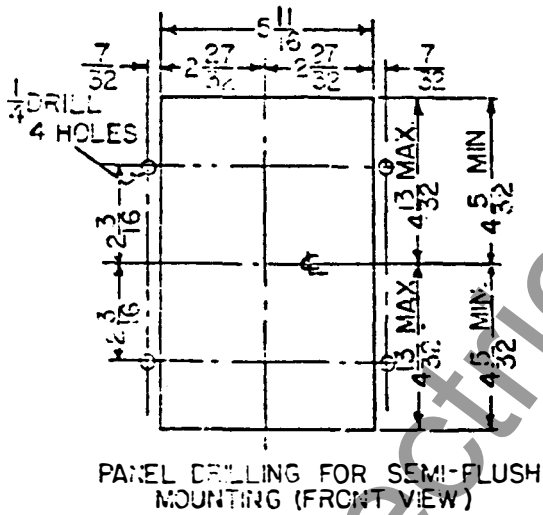

PANEL DRILLING FOR SEMI-FLUSH MOUNTING (FRONT VIEW)

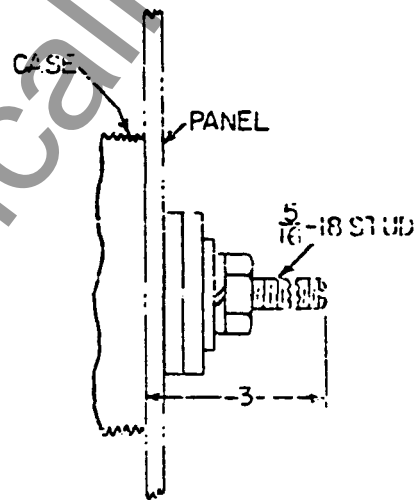

VIEW SHOWING ASSEMBLY OF HARDWARE FOR SURFACE MTG. ON STEEL PANELS

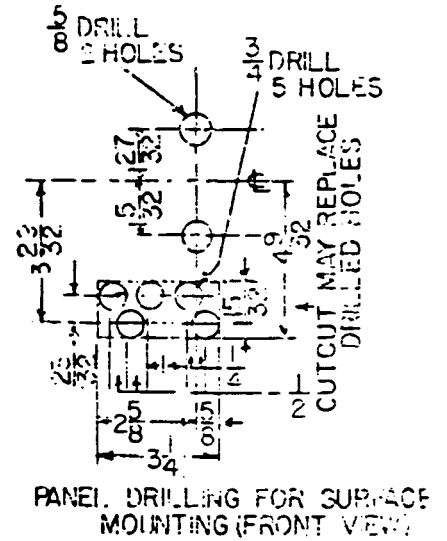

PANEL DRILLING FOR SURFACE MOUNTING (FRONT VIEW)

FIG. 14 (K6209270-2) OUTLINE AND PANEL DRILLING FOR RELAY TYPES IAV51D, 52D AND IAV52C

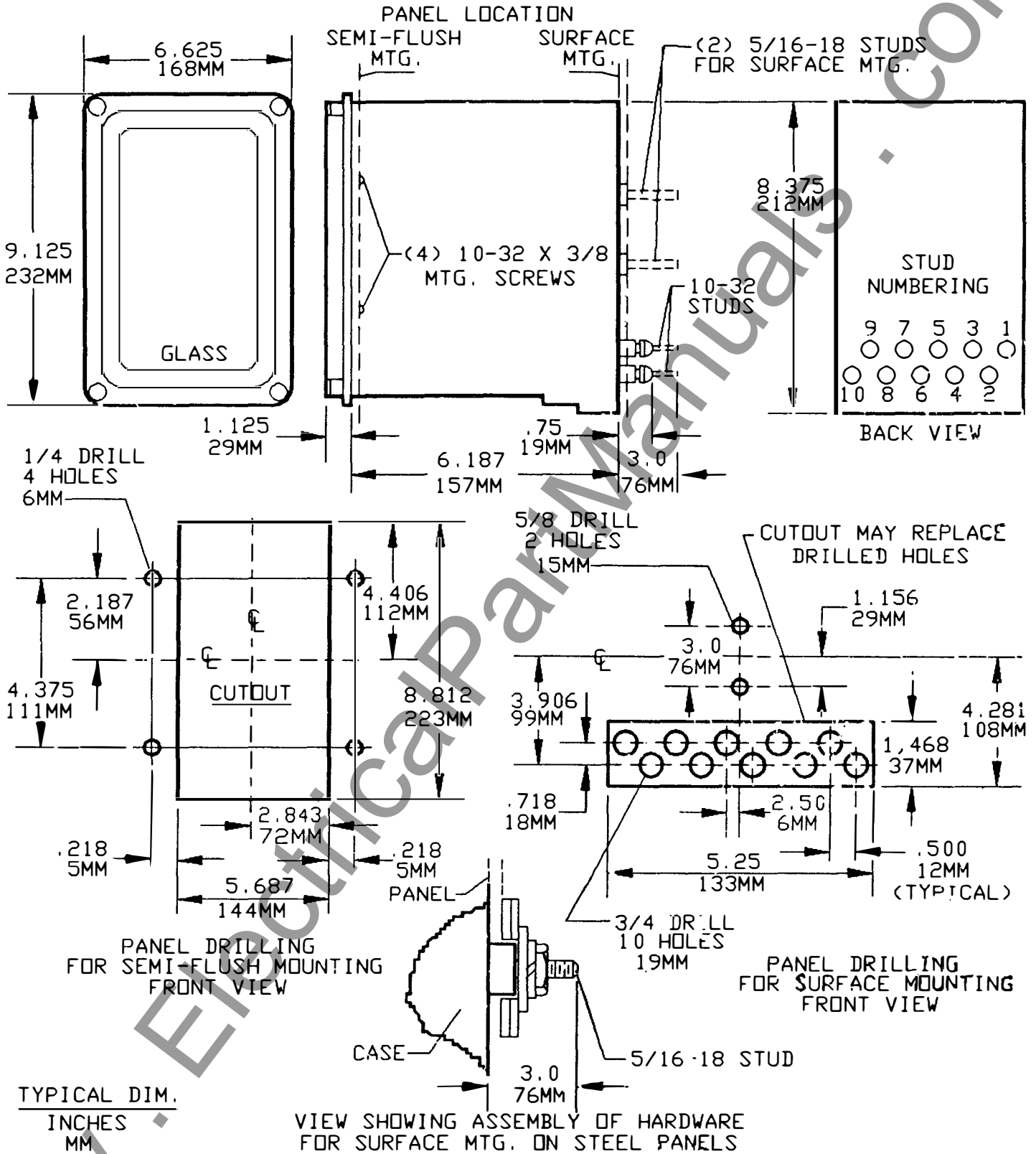

* FIG. 15 (K6209271-8) OUTLINE AND PANEL DRILLING FOR RELAY TYPES IAV51K AND IAV52K

* Indicates Revision

www.ElectricalPartManuals.com

**Protection and Control
Business Department**

(6/93) (2000)

General Electric Company
205 Great Valley Parkway
Malvern, Pennsylvania 19355-0715