



INSTRUCTIONS

**MULTI-CONTACT
AUXILIARY RELAYS**

TYPE HFA153K

CONTENTS

	<u>PAGE</u>
DESCRIPTION	3
APPLICATION	3
RATINGS	4
CHARACTERISTICS	4
BURDENS	5
RECEIVING, HANDLING AND STORAGE	5
INSTALLATION	5
ADJUSTMENTS	5
PICKUP	5
PICKUP TIME	6
CONTACTS	6
Normally-Open Contact Wipe and Gap	6
Normally-Closed Contact Gap and Wipe	7
Long-Wipe Normally-Closed Contact	7
MAINTENANCE	7
CONTACT CLEANING	7
RENEWAL PARTS	7

www.ElectricalPartManuals.com

MULTI-CONTACT AUXILIARY RELAYS

TYPE HFA153K

DESCRIPTION

The Type HFA153K relays are instantaneous, hinged armature, multi-contact, auxiliary relays. They have five electrically separate contact circuits adaptable for either circuit opening or circuit closing applications. This arrangement permits a number of operations to be performed simultaneously. A sixth contact in the Number 3 position inserts an external resistor in series with the opening coil as soon as the relay picks up.

The HFA153K relays are available as back connected semi-flush mounted relays, HFA153K(-)F, or as front connected surface mounted relays, HFA153K(-)H. See Figure 1 and 2.

APPLICATION

The Type HFA153K relays are intended for applications where a high-speed auxiliary tripping relay is required to control up to five circuits. With rated voltage applied, the maximum number of targets that can be reliably operated by the HFA operating current is as shown in Table I. If more than this number of targets are used, current division may prevent some or all of the targets from operating.

TABLE I

Relay	Applied Volts	Target Rating	No. of Targets Operated
HFA153K1	250 VDC	0.2A	2
		0.6A	1
HFA153K2	125 VDC	0.2A	3
		0.6A	1
		1.0A	1
HFA153K4	48 VDC	0.6A	3
		1.0A	3
HFA153K5	24 VDC	1.0A	3

These instructions do not purport to cover all details or variations in equipment nor provide for every possible contingency to be met in connection with installation, operation or maintenance. Should further information be desired or should particular problems arise which are not covered sufficiently for the purchaser's purposes, the matter should be referred to the General Electric Company.

To the extent required the products described herein meet applicable ANSI, IEEE and NEMA standards; but no such assurance is given with respect to local codes and ordinances because they vary greatly.

RATINGS

The Type HFA relays are available with coil ratings for 24, 48, 125 and 250 volts DC. The coils are designed for long life even when the relay is operated continuously in a maximum ambient temperature.

The current-closing rating of each contact is 30 amperes. The current-carrying rating is 12 amperes continuous, 30 amperes for one minute and 125 amperes for one second. Table II lists the non-inductive interrupting capacity of each contact.

TABLE II

DC		AC	
Volts	Amperes	Volts	Amperes
12	30	115	30
24	15	230	20
32	10	460	15
48	8	575	10
125	3		
250	1		

CHARACTERISTICS

The Number 3 position contacts are built with a special offset. The use of these contacts requires an additional strong contact spring to prevent contact bounce. The contacts are designated as long-wipe contacts.

The HFA153K relays are self-reset and have an instantaneous dropout.

The relays are designed to be connected with an external resistor to obtain a pickup time of eight milliseconds or less; see Figure 6.

The contact code must be specified by the arrangements listed in Table III. Only those contact arrangements listed are available.

TABLE III

Relay	Code	CONTACT ARRANGEMENT					
		Position					
		1	2	3	4	5	6
HFA153K	1	a	a	b1	a	a	a
	2	a	a	b1	a	b	a
	3	a	a	b1	b	b	a

- a = Normally open contact
- b = Normally closed contact
- b1 = Normally closed contact, long wipe

BURDENS

TABLE IV

MODEL NUMBER	VOLTAGE	COIL RESISTANCE OHMS @ 25°C +10%	EXTERNAL RESISTANCE OHMS + 5%
12HFA153K1	250 VDC	82.2	800
12HFA153K2	125 VDC	20.2	200
12HFA153K4	48 VDC	2.9	30
12HF153K5	24 VDC	0.76	7.5

RECEIVING, HANDLING AND STORAGE

These relays, when not included as part of a control panel will be shipped in cartons designed to protect them against damage. Immediately upon receipt of a relay, examine it for any damage sustained in transit. If injury or damage resulting from rough handling is evident, file a damage claim at once with the transportation company and promptly notify the nearest General Electric Apparatus Sales Office.

Reasonable care should be exercised in unpacking the relay in order that none of the parts are injured or the adjustments disturbed.

If the relays are not to be installed immediately, they should be stored in their original cartons in a place that is free from moisture, dust and metallic chips. Foreign matter collected on the outside of the case may find its way inside when the cover is removed, and cause trouble in the operation of the relay.

INSTALLATION

The Type HFA relays should be mounted on a vertical surface. The outline and panel drilling diagrams are shown in Figures 4 and 5. The internal connections are shown in Figure 3.

The relays are shipped from the factory with all necessary adjustments made. If the relays should need adjustments, refer to the **MAINTENANCE** section of this book.

ADJUSTMENTS*PICKUP**

The relays are adjusted at the factory to pick up at 40 - 50% of rating for DC coils. Normally these adjustments should not change; if it is necessary to readjust the relay, the armature-adjusting nut should be lifted 1/16 inch, turned clockwise to raise pickup or counterclockwise to lower pickup, and then reseated in the hexagonal groove in the armature tailpiece.

*Revised since last issue

After the relay has been mounted it should be operated a few times to be certain that the mechanism operates freely, that the contact surfaces align properly, and that self-reset models drop out quickly when the coil is de-energized.

PICKUP TIME

The HFA153K relays should pick up in eight milliseconds (8 ms) or less when rated voltage is applied across the resistor and relay coil combination. This time may be altered by adjustment of the armature stop screw.

CONTACTS

The contacts are adjusted at the factory and should not require readjustment since they are self-aligning.

* HFA153K contact circuits, other than the DI contact, can be changed from circuit-opening to circuit-closing, or vice versa, by just removing the fixed contact, turning it over and replacing it. Moving the contact, by bending, may be required to obtain simultaneous contact closure.

If for any reason it becomes necessary to readjust the contacts, the following checks and adjustments should be made:

1. Make sure that all contact and coil studs are tight.
2. Make sure that the armature is free of binding when operated by hand. The braided "pigtail" lead on all contacts must be adjusted to exert minimum force on the contacts.
3. Make mechanical contact adjustments as follows:

Normally-Open Contact Wipe and Gap (Normally-open contacts shall be adjusted before normally-closed contacts).

The moving contact arms shall be adjusted so that the normally-open contacts make the approximately simultaneously ($\pm .008$ inch) when the relay is operated by hand. All normally-open contacts shall have a wipe of 1/32 to 3/64 inches with the armature fully picked up. The contact gap shall be approximately 5/32 inch. This can be adjusted as follows:

- i) Insert a 0.042 gage between the armature and pole face and close the armature.
- ii) Bend the left-hand moving contact to just light the continuity lamp.
- iii) Remove the 0.042 gage and bend the remaining moving contacts so that all moving contacts make at approximately the same time.
- iv) To check performance, turn the stop screw in until one contact continuity lamp is lit. Turn the stop screw in an additional 1/2 turn and all continuity lamps should be lit. Back off the stop screw to obtain at least 1/4 inch contact gap.
- v) Insert a 5/32-inch gage between any of the normally-open moving and stationary contacts, and turn the stop screw clockwise until the continuity lamp lights. Lock the stop screw in this position with the locking nut.

* Indicates Revision

Normally-Closed Contact Gap and Wipe

The moving contact arms shall be adjusted so that the normally-closed contacts make approximately simultaneously ($\pm .008$) when the relay is operated by hand. The wipe and gap are automatically set by the formation of the stationary contacts and the strength of the control spring. Adjustments can be made as follows:

- i) Turn the stop screw clockwise until the first normally-closed contact opens.
- ii) Turn the stop screw an additional 1/2 turn clockwise. All normally-closed contacts should be open.
- iii) Turn the stop screw counterclockwise until there is approximately 1/8" gap between the stop screw and armature. Lock the stop screw in this position.

Recheck pickup after the above changes or adjustments have been made.

Long-Wipe Normally-Closed Contact

- * i) With the armature fully picked up, the b1 contact gap should 3/16 inch to 1/4 inch.

MAINTENANCE *CONTACT CLEANING

In cleaning fine silver contacts a flexible burnishing tool should be used. This consists of a flexible strip of metal with an etch-roughened surface, resembling in effect a superfine file. The polishing action is so delicate that no scratches are left, yet corroded material will be removed rapidly and thoroughly.

Fine silver contacts should not be cleaned with knives, files or abrasive paper or cloth.

The burnishing tool described is included in the standard XRT11A relay tool kit obtainable from the factory.

RENEWAL PARTS

When ordering renewal parts, address the nearest Sale Office of the General Electric Company, specify the quantity required, the name of the part wanted, and give the complete nameplate data. The renewal parts publication is GEF-2757.

* Indicates Revision

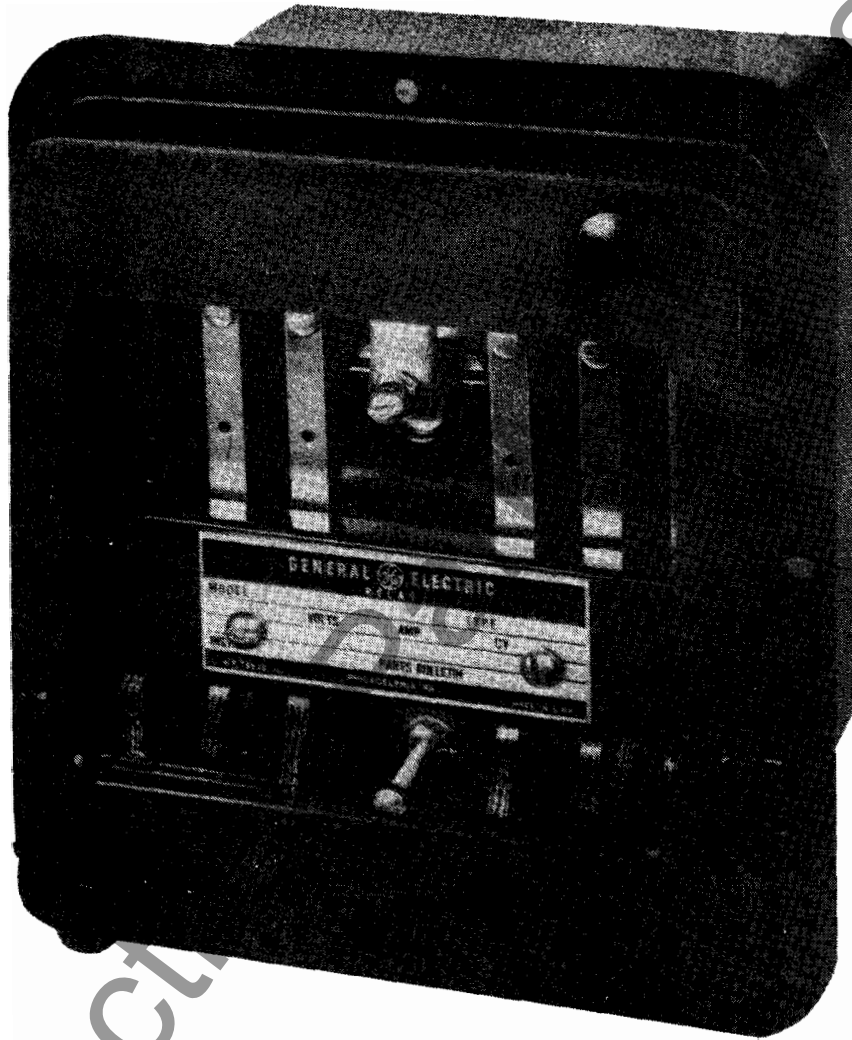

Figure 1 (8042731) Back Connected HFA Relay with Flange for Semi-flush Mounting (Front View)

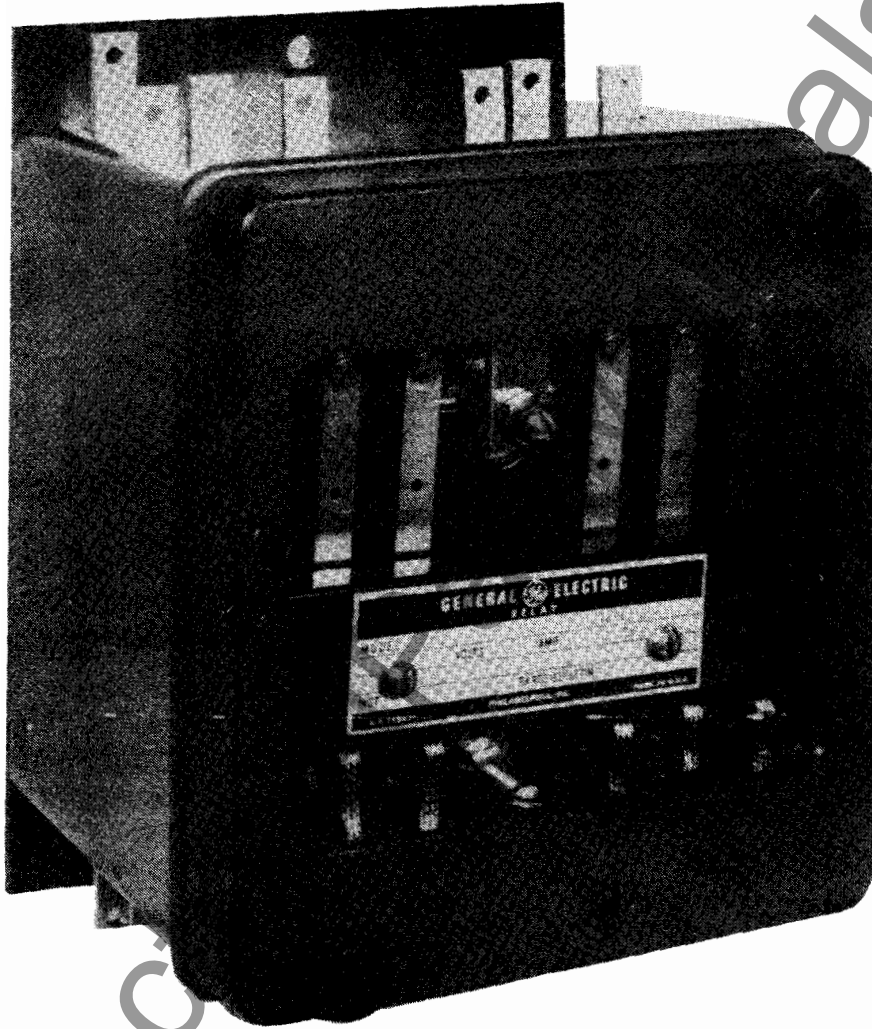
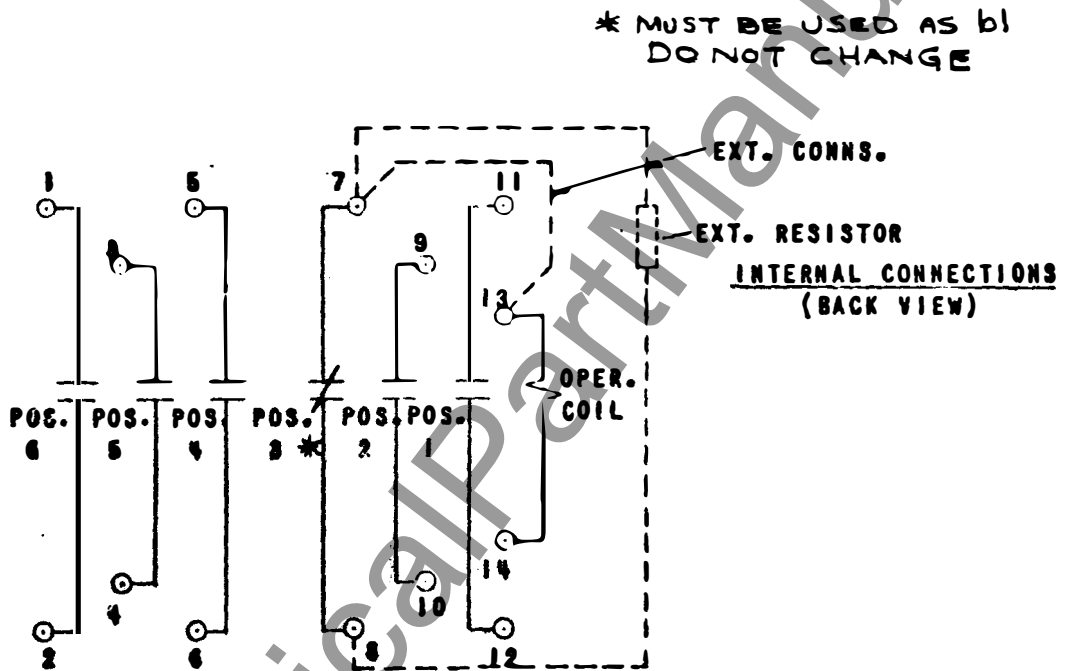
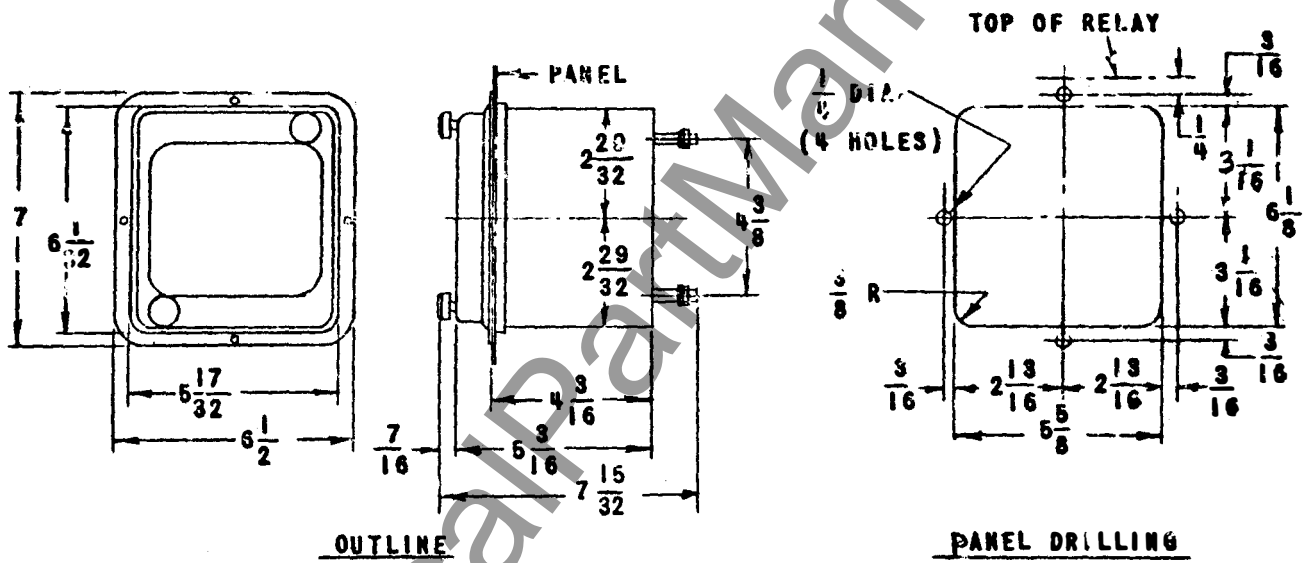

Figure 2 (8043606) Front Connected Surface Mounted HFA Relay (Front View)



*Figure 3 (0418A0799, Sh.1, bottom [8]) Internal Connections for HFA153K Relay (Back View)

*Revised since last issue



*Figure 4 (0418A0799, Sh.1, top [8]) Outline and Panel Drilling Dimensions for HFA153K Relay for Semi-flush Mounting

*Revised since last issue

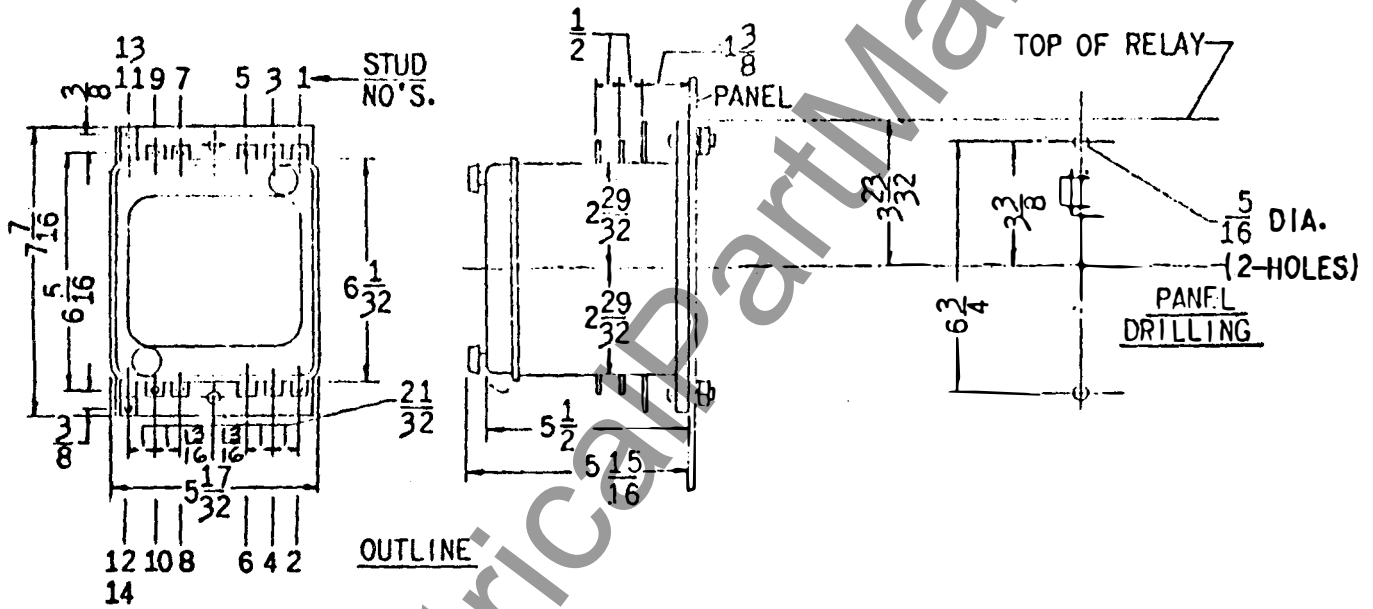
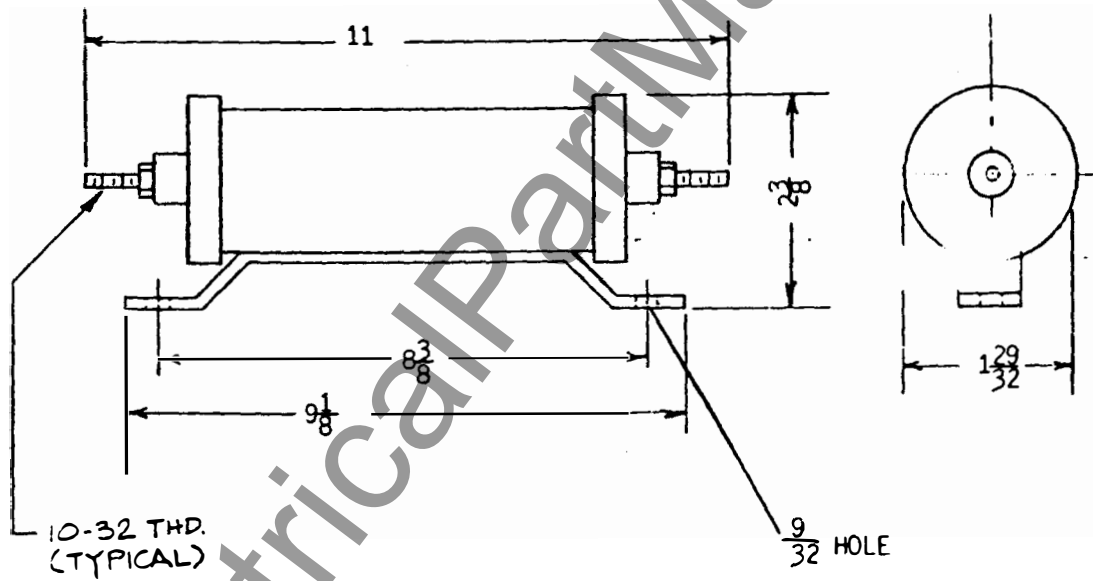

Figure 5 (0104A8527, Sh.1 [5]) Outline and Panel Drilling Dimensions for HFA153K Relays for Surface Mounting, Front Connected



* Figure 6 (0389A0752 [2]) Outline of External Resistor used with HFA153K Relays

* Indicates revision

- Figure 1 (8042731) Back Connected HFA Relay with Flange for Semi-flush Mounting (Front View)
- Figure 2 (8043606) Front Connected Surface Mounted HFA Relay (Front View)
- Figure 3 (0418A0799, Sh.1, bottom [7]) Internal Connections for HFA153K Relay (Back View)
- Figure 4 (0418A0799, Sh.1, top [7]) Outline and Panel Drilling Dimensions for HFA153K Relay for Semi-flush Mounting
- Figure 5 (0104A8527, Sh.1 [5]) Outline and Panel Drilling Dimensions for HFA153K Relays for Surface Mounting, Front Connected
- Figure 6 (0389A0752-1) Outline of External Resistor used with HFA153K Relays

www.ElectricalPartManuals.com

www.ElectricalPartManuals.com

**Meter and Control
Business Department**

BC-6/95 (600)

General Electric Company
Protection and Control
205 Great Valley Parkway
Malvern, Pennsylvania 19355-1337