



INSTRUCTIONS

GEK-45490

INSTANTANEOUS AUXILIARY RELAYS

TYPES HMA124A, HMA125A

POWER SYSTEMS MANAGEMENT DEPARTMENT

GENERAL  ELECTRIC

PHILADELPHIA PA

CONTENTS

| | PAGE |
|--|------|
| DESCRIPTION..... | 3 |
| APPLICATION..... | 3 |
| RATINGS..... | 3 |
| CHARACTERISTICS..... | 3 |
| BURDENS..... | 3 |
| CONSTRUCTION..... | 4 |
| RECEIVING, HANDLING AND STORAGE..... | 4 |
| ACCEPTANCE TESTS..... | 4 |
| PICKUP TEST..... | 4 |
| INSTALLATION..... | 4 |
| PERIODIC CHECKS AND ROUTINE MAINTENANCE..... | 4 |
| CONTACT CLEANING..... | 5 |
| SERVICING..... | 5 |
| MECHANICAL ADJUSTMENTS..... | 5 |
| RENEWAL PARTS..... | 5 |

www.ElectricalPartManuals.com

INSTANTANEOUS AUXILIARY RELAYS
 TYPES HMA 124A AND HMA 125A

DESCRIPTION

The Type HMA 124A and HMA 125A relays are instantaneous auxiliary devices whose contacts are opened and closed by the movement of a hinged armature. The operating coil is specially designed for long life even when operated continuously near maximum ambient temperature. The HMA 124A is flush mounted and back connected. The HMA 125A is surface mounted and back connected.

APPLICATION

These relays were specifically designed for seismic purposes and to be used in the General Electric Nuclear Energy Divisions' panels.

RATINGS

These relays are available with coil ratings for 24, 48 and 125 volts DC and for 120 volts 50 TO 60 cycles.

The current-closing rating of the contacts is 30 amperes. The current-carrying rating is 12 amperes continuously or 30 amperes for one minute. The interrupting ratings for the various voltages are as follows:

| VOLTS | | NONINDUCTIVE | | INDUCTIVE | |
|-------|-----|--------------|--------------|--------------|--------------|
| DC | AC | Single Break | Double Break | Single Break | Double Break |
| 6-32 | | 15 Amps | 30 Amps | 7.5 Amps | 20 Amps |
| 48 | | 10 | 20 | 3 | 7.5 |
| 125 | | 1.5 | 3 | 0.75 | 1.0 |
| 250 | | 0.25 | 0.5 | 0.1 | 0.25 |
| | 115 | 20 | 30 | 15 | 15 |
| | 230 | 13 | 25 | 10 | 10 |
| | 460 | 5 | 10 | 5 | 5 |

CHARACTERISTICS

These relays are hinged-armature type, instantaneous auxiliary devices. When the coil is energized, a magnetic flux flows through the frame pole piece and attracts the armature. Two auxiliary contacts are mechanically coupled to the armature. The auxiliary contacts are two form "C" contacts (see internal connections diagrams). These contacts can be used to make or break auxiliary circuits.

BURDENS

| D-C COILS | | | |
|-----------|-------|----------|---------------|
| VOLTS | FREQ. | D-C RES. | WATTS IN COIL |
| 24 | d-c | 225 | 2.6 |
| 48 | d-c | 950 | 2.4 |
| 125 | d-c | 5800 | 2.7 |

Certain quantities should be defined before giving BURDEN DATA for a-c coils.

RDC is the resistance of a coil as measured with an ohmmeter, bridge, etc.

These instructions do not purport to cover all details or variations in equipment nor to provide for every possible contingency to be met in connection with installation, operation or maintenance. Should further information be desired or should particular problems arise which are not covered sufficiently for the purchaser's purposes, the matter should be referred to the General Electric Company.

To the extent required the products described herein meet applicable ANSI, IEEE and NEMA standards; but no such assurance is given with respect to local codes and ordinances because they vary greatly.

R_{DO} is the a-c resistance of a coil when a-c power is flowing through the coil but the relay is not picked up. X_{DO} is the inductive impedance when the coil is energized but the relay is not picked up. The resistive and inductive parts of impedance of coil under picked up conditions are designated as R_{PU} and X_{PU} .

Z_{DO} is the impedance of the relay in dropout conditions. Z_{PU} is the impedance of the relay in picked up conditions.

| A-C COILS | | | | | | | | |
|----------------|------------------|-------------------|-------------------|-------------------|-------------------|------------------|------------------|------------------|
| COILS VOLTS | RATINGS CYCLE | R_{DC} ± 10% | R_{DO} ± 10% | X_{DO} ± 10% | Z_{DO} ± 10% | R_{PU} ± 5% | X_{PU} ± 5% | Z_{PU} ± 5% |
| 120 | 60 | 345 | 503 | 964 | 1087 | 1389 | 1534 | 2069 |
| 120 | 50 | 517 | 595 | 1031 | 1190 | 1567 | 1838 | 2415 |

CONSTRUCTION

The HMA124A and HMA125A are instantaneous hinged armature auxiliary relays with long life coils capable of continuous operation near maximum ambient temperature. The relays are mounted on the molded base of an NGA relay. The HMA124A has a glass cover and is flush-mounted back-connected. The HMA125A has a glass cover and is surface-mounted back-connected. The relays were specifically designed for seismic purposes and to be used in General Electric Nuclear Energy Divisions' panels.

The contacts are two form "C" contacts, DPDT, as shown by Figs. 1 and 2. Fig. 1 is the outline, panel drilling and internal connections diagram for the HMA124A relay. Fig. 2 is the outline, panel drilling and internal connections diagram for the HMA125A relay.

RECEIVING, HANDLING AND STORAGE

These relays, when not included as a part of a control panel will be shipped in cartons designed to protect them against damage. Immediately upon receipt of a relay, examine it for any damage sustained in transit. If injury or damage resulting from rough handling is evident, file a damage claim at once with the transportation company and promptly notify the nearest General Electric Apparatus Sales Office.

Reasonable care should be exercised in unpacking the relay in order that none of the parts are injured or the adjustments disturbed.

If the relays are not to be installed immediately, they should be stored in their original cartons in a place that is free from moisture, dust and metallic chips. Foreign matter collected on the outside of the case may find its way inside when the cover is removed and cause trouble in operation of the relay.

ACCEPTANCE TESTS

PICK UP TEST

Pickup is defined as the minimum voltage at which the armature operates and seals firmly against the pole piece. The two movable contacts are electrically separate and are held in position on the armature by means of an insulated contact carrier and spring housing. The control spring tension (see Fig. 1) can be adjusted by bending the anchor arm. The spring should be adjusted so that the highest value of pickup is obtained without exceeding 80 percent of rated AC volts or 60 percent of rated DC volts.

The pickup time to close a normally open contact for AC relays at rated voltage and frequency is between 16 to 32 milliseconds. The pickup time for DC relays at rated voltage is between 24 and 33 milliseconds.

The pickup and dropout voltage for DC relays, after being continuously energized at rated voltage, increases by 10 percent to 20 percent. Similarly, in the case of AC relays, the pickup and dropout voltage increases by 3 percent to 8 percent.

INSTALLATION

The relays should be mounted on a vertical surface in a location that is clean, dry, and free from excessive vibration. Care should be taken to allow sufficient clearance in front of the relay to remove the cover.

Refer to Figs. 1 and 2 for mounting dimensions and internal connections.

PERIODIC CHECKS AND ROUTINE MAINTENANCE

In view of the vital role of relays in the operation of a power system it is important that a periodic test program be followed. It is recognized that the interval between periodic checks will vary depending upon environment, type of relay and the user's experience with periodic testing. Until the user has accumulated enough experience to select the test interval best suited to his individual requirements, it is suggested that the pickup voltage can be checked on the same schedule as the associated protective relays.

CONTACT CLEANING

For cleaning relay contacts, a flexible burnishing tool should be used. This consists of a flexible strip of metal with an etched-roughened surface resembling in effect a superfine file. The polishing action is so delicate that no scratches are left, yet it will clean off any corrosion thoroughly and rapidly. Its flexibility insures the cleaning of the actual points of contact. Do not use knives, files, abrasive paper or cloth of any kind to clean relay contacts.

SERVICINGMECHANICAL ADJUSTMENTS

There should be at least 1/16 inch wipe on the normally closed "b" contacts and the normally open "a" contacts as measured at the top of the moving contact carrier. To determine, operate the armature by hand and check that there is at least 1/16 inch movement of the top edge of the contact carrier after the contacts have made.

When the armature is operated by hand, the "a" contact should make within 1/32 inch of each other, i.e., with one contact just making, the gap of the other should never be more than 1/32 inch. This also applies to the "b" contacts.

For all back connected relays with cover, check that there is at least 1/32 inch clearance between the armature tailpiece and the bottom inside surface of the cover.

RENEWAL PARTS

It is recommended that sufficient quantities of renewal parts be carried in stock to enable the prompt replacement of any that are worn, broken, or damaged.

When ordering renewal parts, address the nearest Sales Office of the General Electric Company, specify quantity required, name of the part wanted, and the complete model number of the relay for which the part is required.

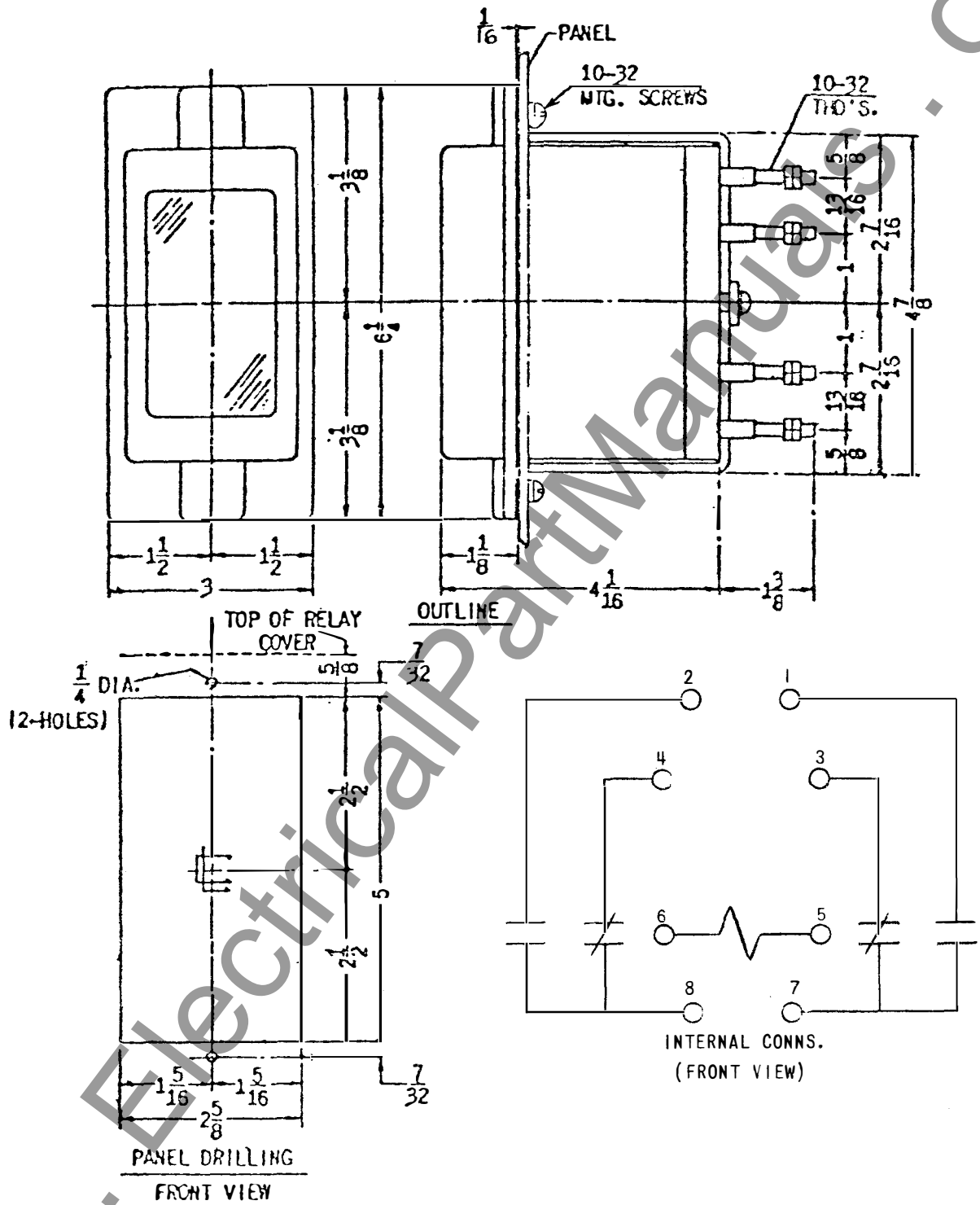
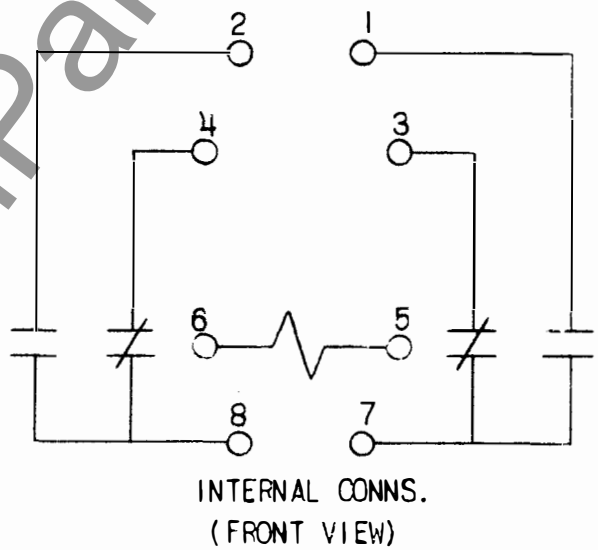
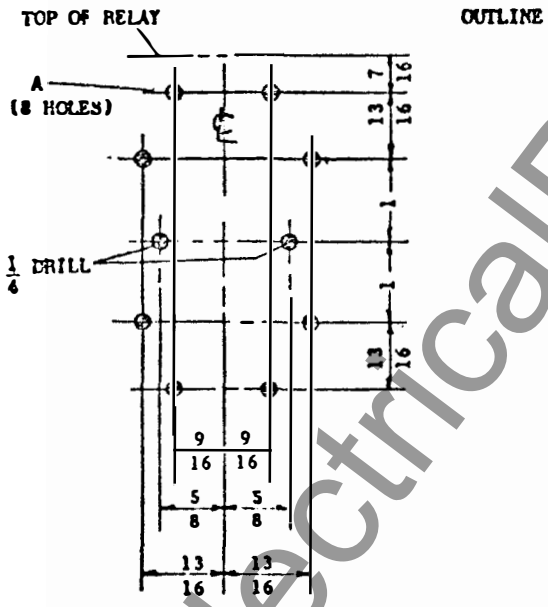
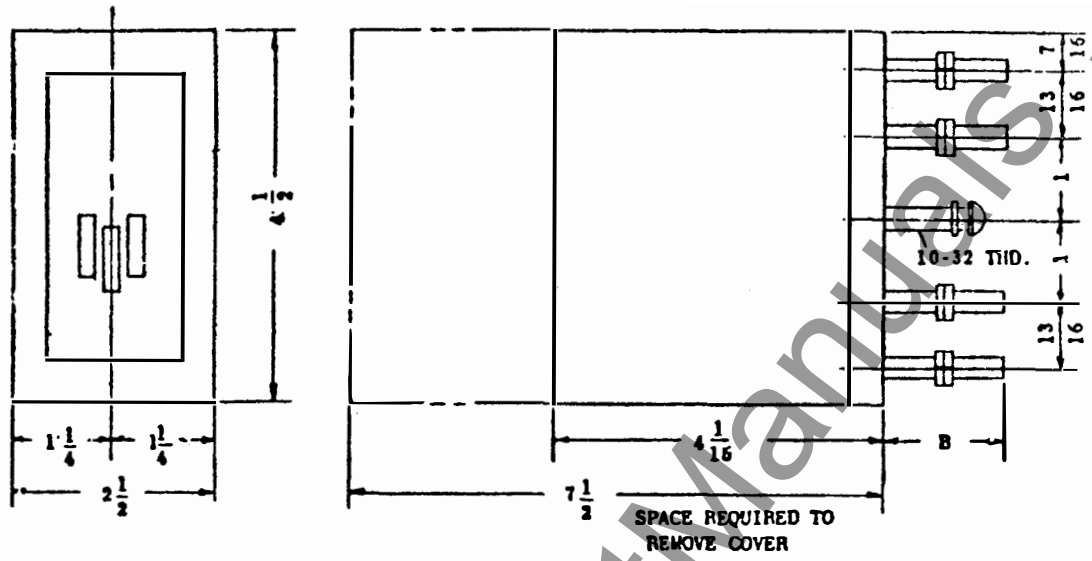

Fig. 1. (0246A3399-0) Outline, Panel Drilling and Internal Connections for HMA 124A Relay



| TYPE OF PANEL | A | B |
|---------------|------|---------|
| INSULATING | 7/16 | 2-13/16 |
| STEEL | 9/16 | 1-3/8 |

PANEL DRILLING (FRONT VIEW)

Fig. 2 (0246A3650-0) Outline, Panel Drilling and Internal Connections for HMA 125A Relay

www.ElectricalPartManuals.com



**Meter and Control
Business Department**

(ST-7/92) (200)

General Electric Company
205 Great Valley Parkway
Malvern, PA 19355