



INSTRUCTIONS

MULTI-CONTACT AUXILIARY RELAYS

TYPE HFA173K



GE Meter and Control
205 Great Valley Parkway
Malvern, PA 19355-1337

www.Elect

Manuals.com

CONTENTS

	<u>PAGE</u>
DESCRIPTION	3
APPLICATION	3
CHARACTERISTICS	4
RATINGS	4
BURDEN AND PICKUP VOLTAGE	4
CONTACT CODE	5
RECEIVING, HANDLING AND STORAGE	5
INSTALLATION	5
MAINTENANCE	6
CONTACT CLEANING	6
ADJUSTMENTS	6
CONTACT ADJUSTMENTS	6
PICKUP	7
PICKUP TIME	7
PERIODIC CHECKS AND ROUTINE MAINTENANCE	8
RENEWAL PARTS	8

Figure 1 (8042299) Cover

MULTI-CONTACT AUXILIARY RELAYS

TYPE HFA173K

DESCRIPTION

The Type HFA173K relay is a high-speed, multi-contact auxiliary relay of the hinged-armature type construction. Pickup time for the relay is one-half cycle.

The Type HFA173K relay is mounted in a double-ended S2-size case. The internal connections for the relay are shown in Figure 2. Outline and panel-drilling dimensions are shown in Figure 3.

The operating coils are designed for long life even when operated continuously near maximum ambient temperature.

APPLICATION

The Type HFA173K relays are intended for application where a high-speed auxiliary tripping relay is required to control up to five (5) circuits. When operated at rated voltage, the relay operating-circuit current will drop the number of targets listed in Table I.

TABLE I

RELAY	APPLIED VOLTAGE	TARGET RATING	NO. OF TARGETS DROPPED
HFA173K1A	250 VDC	0.2 Amp	2
		0.6 Amp	1
HFA173K2A	125 VDC	0.2 Amp	3
		0.6 Amp	1
		1.0 Amp	1
HFA173K4A	48 VDC	0.6 Amp	3
		1.0 Amp	2

These instructions do not purport to cover all details or variations in equipment nor provide for every possible contingency to be met in connection with installation, operation or maintenance. Should further information be desired or should particular problems arise which are not covered sufficiently for the purchaser's purposes, the matter should be referred to the General Electric Company

To the extent required the products described herein meet applicable ANSI, IEEE and NEMA standards; but no such assurance is given with respect to local codes and ordinances because they vary greatly.

CHARACTERISTICS

The HFA173K(-)A relays are designed with an internal resistor to obtain pickup time of 8.5 ms \pm 0.5 milliseconds. They are only available with the contact code shown in Table IV. The operating principle is as follows:

Initially the coil current is limited only by the resistance of the coil because Position 4 is a normally-closed, long wipe contact. After the relay picks up, Position 4 opens and inserts the internal resistor in series with the coil, thereby reducing the coil current. This allows the coil current to be continuously rated in the operating position.

RATINGS

The HFA173K relays are available with coil ratings for 24, 48, 125 and 250 volts DC.

The current-closing rating of each contact is 30 amperes. The current-carrying rating is 12 amperes continuous. Table II lists the non-inductive interrupting capacity of each contact.

TABLE II

DC	
VOLTS	AMPERES
24	15
48	8
125	3
250	1

BURDEN AND PICKUP VOLTAGE

TABLE III

MODEL NO.	VOLTAGE	COIL RESISTANCE	INTERNAL RESISTOR	PICKUP VOLTAGE
HFA173K1A	250 VDC	82 Ohms	2000 Ohms	125 Volts
HFA173K2A	125 VDC	21 Ohms	500 Ohms	62.5 Volts
HFA173K4A	48 VDC	2.9 Ohms	75 Ohms	24 Volts
HFA173K5A	24 VDC	0.76 Ohms	18 Ohms	12 Volts

Pickup voltage values are for a "cold" relay and with the voltage suddenly applied.

The heat produced by the coil and the internal resistor in the S2 case will cause a temperature rise in the case of 25°C \pm 10% above the ambient temperature.

CONTACT CODE

TABLE IV

RELAY	CODE	CONTACT ARRANGEMENT					
		POSITION					
		1	2	3	4	5	6
HFA173K	1	a	a	a	b1	a	a

a = Normally-open contact
 b1 = Normally-closed contact, long wipe

RECEIVING, HANDLING AND STORAGE

These relays, when not included as part of a control panel, will be shipped in cartons designed to protect them against damage. Immediately upon receipt of a relay, examine it for any damage sustained in transit. If injury or damage resulting from rough handling is evident, file a damage claim at once with the transportation company and promptly notify the nearest General Electric Sales Office.

Reasonable care should be exercised in unpacking the relay in order that none of the parts are injured nor the adjustments disturbed.

If the relays are not to be installed immediately, they should be stored in their original cartons in a place that is free from moisture, dust and metallic chips.

INSTALLATION

The Type HFA173K relays should be mounted on a vertical surface. The outline and panel-drilling diagram is shown in Figure 3. The internal connections are shown in Figure 2.

After the relay has been mounted it should be operated a few times to be certain that the mechanism operates freely, and that the contact surfaces align properly and open quickly when the coil is de-energized.

MAINTENANCE

CONTACT CLEANING

For cleaning fine silver contacts, a flexible burnishing tool should be used. This consists of a flexible strip of metal with an etch-roughened surface, resembling in effect a superfine file. The polishing action is so delicate that no scratches are left, yet corroded material will be removed rapidly and thoroughly. The flexibility of the tool ensures the cleaning of the actual points of contact.

Fine silver contacts should not be cleaned with knives, files, abrasive paper or cloth. Knives or files may leave scratches, which increase arcing and deterioration of the contacts. Abrasive paper or cloth may leave minute particles of insulating abrasive material in the contacts, thus preventing closing. The use of contact cleaning sprays or liquids should be avoided because some of these liquids may leave deposits in portions of the relay that may be injurious to materials or components.

The burnishing tool described is included in the standard XRT11A relay tool kit, and can be obtained from the factory.

ADJUSTMENTS

CONTACT ADJUSTMENTS

1. This relay has long wipe (b1) and standard wipe (a) contacts and it is not necessary for the (b1) and (a) contacts to overlap.
2. Extra-hard contact springs are used in the top position of all normally-open contacts.
3. All standard-wipe normally-open contacts should be set for a wipe of 1/32 inch to 3/64 inch with the armature fully picked up. This shorter wipe is necessary because of the stiff contact springs.
4. All standard-wipe normally-open (a) contacts should make within 1/64 inch of each other.
5. The standard-wipe normally-open contact gap should be set at 5/64 inch. This adjustment is to be made with the stop screw.
6. Adjust the moving contact of long-wipe normally-closed (b1) contacts in position (4) so that with the armature fully picked up, the contact gap is 3/36 inch to 1/4 inch.
7. Normally-Open Contacts Wipe and Gap (Normally-open contacts and long-wipe normally-closed shall be adjusted before other normally-closed contacts).
 - a. The moving contact arms shall be adjusted so that the normally-open contacts make approximately simultaneously ($\pm .008$ mils) when the relay is operated by hand. All normally-open contacts shall have a wipe of 3/64 to 3/32 inches. The contact gap shall be approximately 7/32 inch. This can be adjusted as follows:
 - i) Insert a 0.058 gage between the armature and pole face and close the armature.
 - ii) Bend the left-hand moving contact to just light the continuity lamp.
 - iii) Remove the 0.058 gage and bend the remaining moving contacts so that all moving contacts make at approximately the same time.

- iv) To check performance, turn the stop screw in until one contact continuity lamp is lit. Turn stop screw in an additional 1/2 turn and all continuity lamps should be lit.

Back off the stop screw to obtain at least 1/4 inch contact gap.

- v) Insert a 7/32 inch gage between any of the normally-open moving and stationary contacts and turn the stop screw clockwise until the continuity lamp lights. Lock the stop screw in this position with the locking nut.

8. Normally-Closed Contact Gap and Wipe

- a. The moving contact arms shall be adjusted so that the normally-closed contacts make approximately simultaneously ($\pm .008$) when the relay is operated by hand. The wipe and gap are automatically set by the formation of the stationary contacts and the strength of the control spring. Adjustments can be made as follows:
 - i) Turn the stop screw clockwise until the first normally-closed contact opens.
 - ii) Turn the stop screw an addition 1/2 turn clockwise. All normally-closed contacts should be open.
 - iii) Turn stop screw counterclockwise until there is approximately 1/8 gap between the stop screw and armature. Lock screw in this position.

PICKUP

The relays are adjusted at the factory to pick up at 50% of rating for DC coils. Normally these adjustments should not change. If it is necessary to readjust the relay, the adjusting nut should be lifted 1/16-inch, turned (clockwise to raise pickup, or counterclockwise to lower pickup), and then reseated in the hexagonal groove in the armature tailpiece.

After the relay has been mounted, it should be operated a few times to be certain that the mechanism operates freely and the contact surfaces align properly.

PICKUP TIME

The HFA173K relays should pick up in no more than nine milliseconds (9ms) when rated voltage is applied across the resistor and relay-coil combination. This time may be altered by adjustment of the armature stop screw, which increases or decreases the air gap, and thus increases or decreases the operating time. It should be recognized that any change that significantly reduces the air gap to obtain times less than nine milliseconds (<9 ms) will also reduce the interrupting ratings of the contacts.

PERIODIC CHECKS AND ROUTINE MAINTENANCE

In view of the vital role of protective relays in the operation of a power system, it is important that a periodic test program be followed. It is recognized that the interval between periodic checks will vary depending upon environment, type of relay and the user's experience with periodic testing. Until the user has accumulated enough experience to select the test interval best suited to his individual requirements, it is suggested that the pickup voltage and time and the contact alignment be checked on the same schedule as the associated protective relays.

RENEWAL PARTS

It is recommended that sufficient quantities of renewal parts be carried in stock to enable the prompt replacement of any that are worn, broken or damaged. When ordering renewal parts, address the nearest Sales Office of the General Electric Company, specify quantity required, name of the part wanted, and the complete model number of the relay for which the part is required

Since the last edition, changes have been made in Figure 3

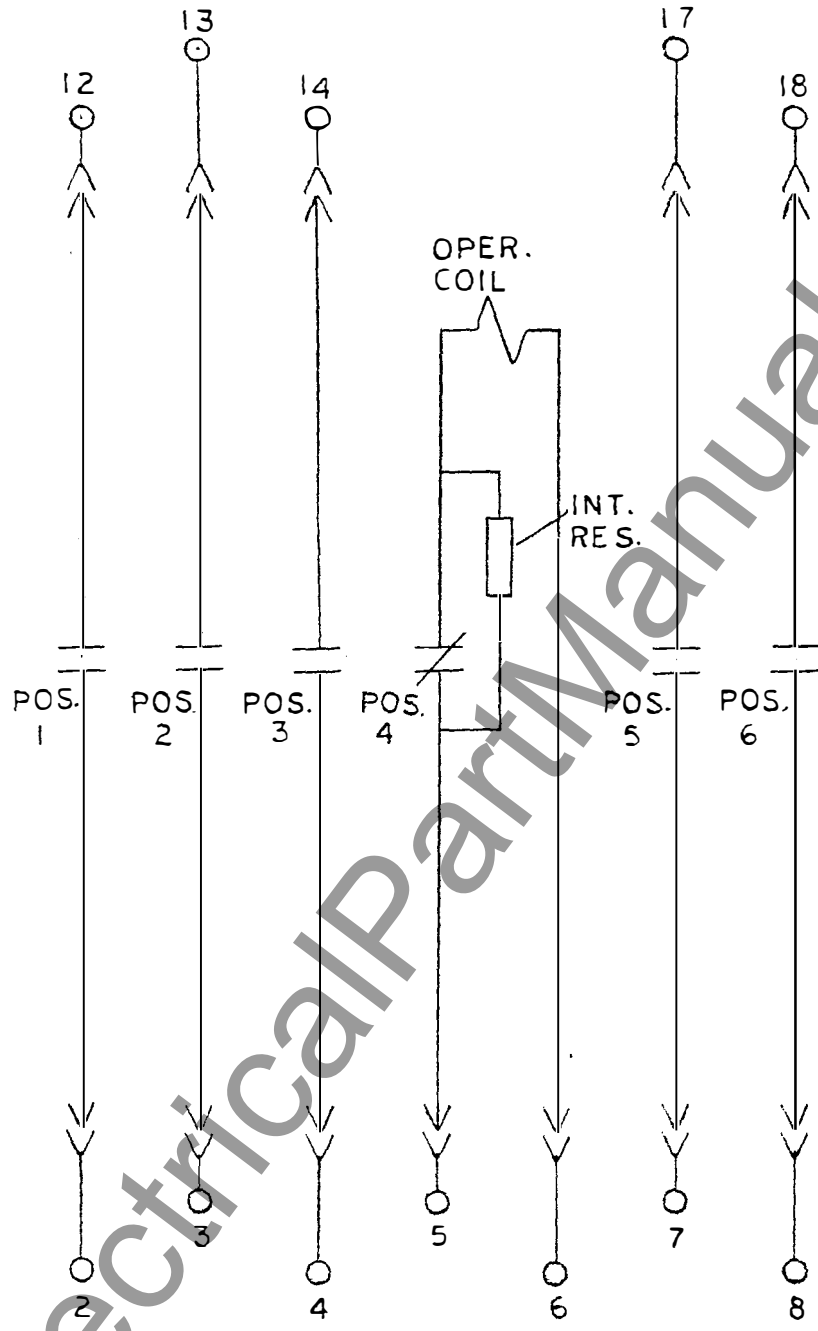

	a	b
CODE NO.	1	
POS. NO.	1	a
	2	a
	3	a
	4	b1
	5	a
	6	a

a = NORMALLY OPEN CONTACT
 a1 = NORMALLY OPEN CONTACT, LONG WIPE
 b = NORMALLY CLOSED CONTACT
 b1 = NORMALLY CLOSED CONTACT, LONG WIPE

Figure 2 (0246A6960-0) Internal Connection Diagram for HFA173K Relays (Front View)

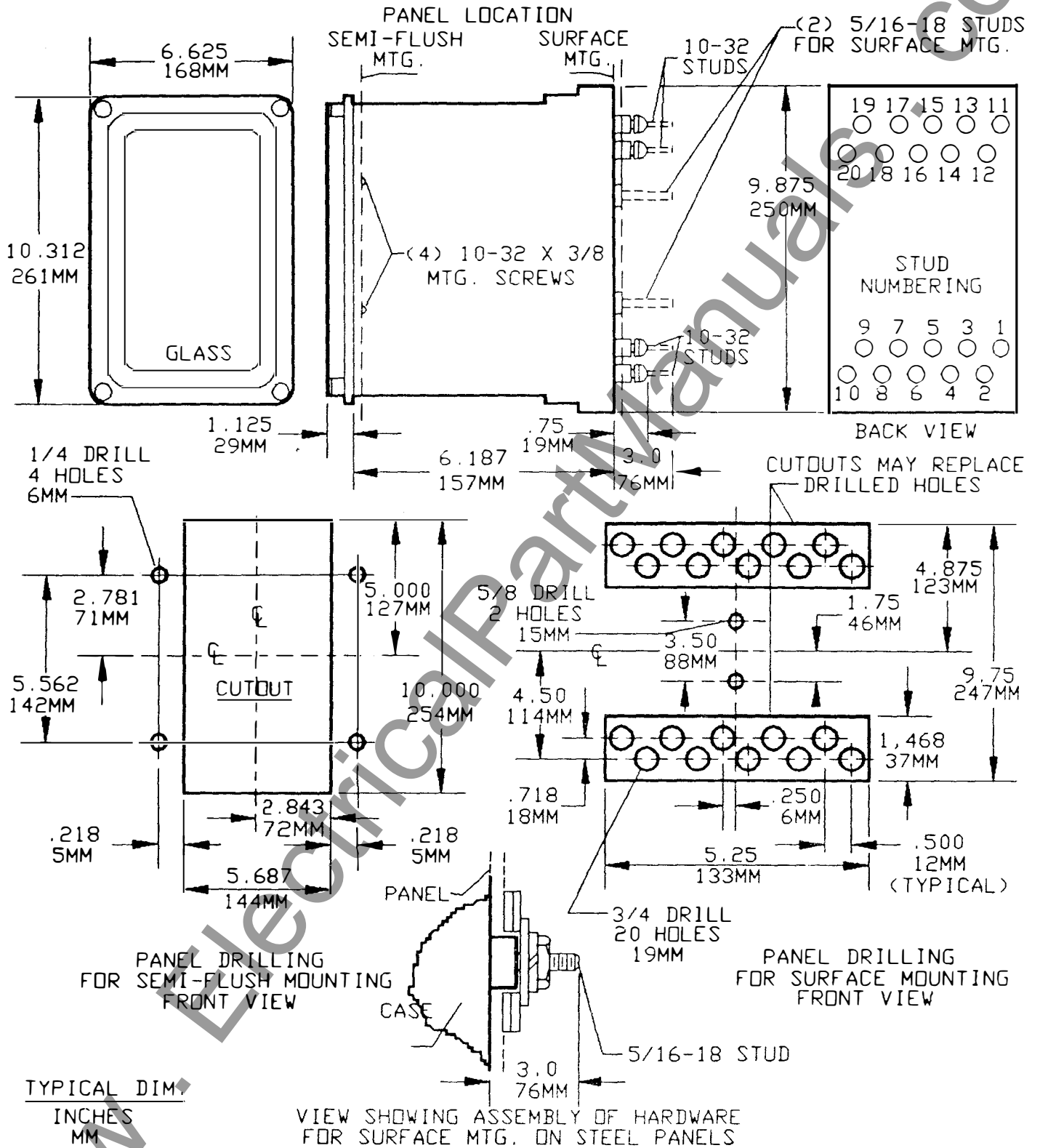

Figure 3 (K-6209272(7)) Outline and Panel-Drilling Diagram for HFA173K Relays

www.ElectricalPartManuals.com

www.ElectricalPartManuals.com



***Meter and Control
Business Department***

ST-4/93) (200)

General Electric Company
Protection and Control
205 Great Valley Parkway
Malvern, Pennsylvania 19355-1337