



# **INSTRUCTIONS**

---

## **STATIC PILOT WIRE MONITORING RELAY**

### **TYPES:**

**SPA11A  
SPA11B  
SPA12A  
SPA12B**

*GE Protection and Control  
205 Great Valley Parkway  
Malvern, PA 19355-1337*

*www.ElectricalPLCManuals.com*

CONTENTS

	<u>PAGE</u>
<b>INTRODUCTION</b> .....	3
<b>APPLICATION</b> .....	3
<b>OPTIONS AND FEATURES</b> .....	4
<b>RATINGS</b> .....	5
TEMPERATURE .....	5
DIELECTRIC STRENGTH .....	5
CONTACTS .....	5
TARGET SEAL-IN UNIT .....	5
SEISMIC CAPABILITY .....	6
<b>CHARACTERISTICS</b> .....	6
OPERATING PRINCIPLES .....	6
OPEN PILOT WIRES .....	7
SHORTED PILOT WIRES .....	7
GROUNDED PILOT WIRES .....	7
OPERATING TIMES .....	7
TRANSFER TRIP .....	8
LOW PASS FILTER .....	9
BURDENS .....	9
<b>SETTINGS</b> .....	9
<b>CONSTRUCTION</b> .....	10
<b>RECEIVING, HANDLING AND STORAGE</b> .....	12
<b>ACCEPTANCE TESTS</b> .....	12
VISUAL INSPECTION .....	13
MECHANICAL INSPECTION .....	13
CRADLE AND CASE BLOCKS .....	13
TARGET SEAL-IN UNIT (SPA11B AND 12B) .....	13
TELEPHONE RELAYS .....	13
ELECTRICAL INSPECTION .....	13
250 DC RATING .....	14
<b>SENDING END</b> .....	14
UNDERCURRENT DETECTION (SPA11A AND 11B) .....	14
OVERCURRENT DETECTION (SPA11A AND 11B) .....	14
GROUND DETECTION (SPA11A AND 11B) .....	14
TRANSFER TRIP (SPA11B) .....	14
<b>RECEIVING END</b> .....	15
UNDERCURRENT DETECTION (SPA12A AND 12B) .....	15
TRANSFER TRIP (SPA12B) .....	15
DIELECTRIC TESTS (HIGH POTENTIAL TESTS) .....	15
INTRODUCTION .....	15
HIPOT TESTS .....	16
RESTORING RELAY TO SERVICE .....	17
<b>INSTALLATION PROCEDURE</b> .....	17
SETTING THE TAP OF THE TARGET SEAL-IN UNIT (SPA11B AND 12B) .....	17
SUPPLY VOLTAGE SETTING .....	17
TERMINAL ARRANGEMENT SETTING .....	17
<b>PERIODIC CHECKS AND ROUTINE MAINTENANCE</b> .....	18
CONTACTS .....	18
ELECTRICAL TESTS .....	18
SERVICING .....	19
TELEPHONE RELAYS .....	19
TARGET SEAL-IN UNIT .....	19
<b>RENEWAL PARTS</b> .....	19
<b>LIST OF ILLUSTRATIONS</b> .....	21

## STATIC PILOT WIRE MONITORING RELAY

## TYPES:

SPA11A  
SPA11B  
SPA12A  
SPA12B

## INTRODUCTION

The Type SPA static pilot-wire-monitoring relays are designed for use in conjunction with an SPD pilot-wire system to provide detection of open, shorted, reversed or grounded pilot wires. The relays are powered by a dual-rated, self-contained, isolated DC-to-DC power supply, to reduce the possibility of battery grounds interfering with operation of the pilot-wire scheme. Models are available with 48/110-125 volt DC ratings.

The Type SPA11A and SPA12A relays provide the basic pilot-wire-monitoring functions. The SPA11A is the sending-end relay and operates in conjunction with a Type SPA12A receiving-end relay at the remote terminal (or terminals) of two (or three) terminal lines. These relays will close contacts and operate a light-emitting diode (LED) when an abnormal pilot-wire condition is detected. The Type SPA11B and SPA12B relays include provisions for the transmission and reception of direct transfer-trip signals in either direction, as well as the basic pilot-wire-monitoring functions.

The SPA monitoring scheme uses a low-level DC signal in order to avoid interfering with the primary AC pilot wire signal (SPD relays). Within the SPA relays, the DC monitoring signal is separated from the AC signal by low-pass filters. SPA models are available for use with 50 hertz and 60 hertz SPD relays.

The Types SPA11A, SPA11B, SPA12A and SPA12B are each packaged in the S2 drawout case, the outline and panel drilling of which is shown in Figure 11.

## APPLICATION

The Type SPA static relays are intended for application as pilot-wire-monitoring relays and/or transfer-trip relays. As noted above, they are designed specifically for use with the SPD pilot-wire relaying system.

When only the monitoring function is desired, the Type SPA11A is required at one end of the pilot circuit, designated as the sending end; and the Type SPA12A is required at the remote receiving end, or at both remote ends in the case of a three-terminal line. The SPA11A relay at the sending end circulates a low-level DC current around the pilot loop, which holds the contacts of the undercurrent (UC) functions in both the sending-end and

*These instructions do not purport to cover all details or variations in equipment nor provide for every possible contingency to be met in connection with installation, operation or maintenance. Should further information be desired or should particular problems arise which are not covered sufficiently for the purchaser's purposes, the matter should be referred to the General Electric Company.*

*To the extent required the products described herein meet applicable ANSI, IEEE and NEMA standards; but no such assurance is given with respect to local codes and ordinances because they vary greatly.*

receiving-end relays in the open position. An open pilot wire will result in the closure of the UC contacts and operation of the UC LED at both the sending and receiving ends. A shorted pilot wire, resulting in a significant increase in the monitoring current, will result in closure of the contacts of the overcurrent (OC) function and operation of the OC LED in the sending-end relay, and the closure of the UC function contacts at the receiving end. A grounded pilot-wire circuit will result in closure of the contacts of the ground-detection function and operation of the ground-indicating LED in the sending-end relay.

Specific information on the magnitude of the circulating current, and operating levels of the UC, OC and ground-detection functions, is provided in the section on **CHARACTERISTICS**. Elementary diagrams for the two-terminal and three-terminal applications of the SPA11A and SPA12A relays are provided in Figures 20 and 21 respectively.

When direct transfer tripping over the pilot wire is desired, in addition to the monitoring functions, the SPA11B is required at the sending end and the SPA12B at the receiving end. These "B" relays include the necessary circuits to transmit and receive the direct transfer-trip signals, as well as the functions required to monitor the pilot-wire circuit as previously described. Typical elementary diagrams for a pilot-wire relaying system with monitoring and transferred tripping are provided in Figure 22 for two-terminal lines and in Figure 23 for three-terminal line applications. These diagrams illustrate the two-way transfer-trip application in which the transfer-trip signal is initiated by either the sending-end relay (SPA11B) or the receiving-end relay (SPA12B). When the transfer-trip signal is to be sent in one direction only, the same relays are applied but the TT unit would not be used at the transfer-trip initiating end and the TTA unit would not be used at the transfer-trip receiving end. Diagrams for the one-way transfer-trip application are available upon request.

### OPTIONS AND FEATURES

There are four types of SPA relays: 1) a sending-end relay, 2) a sending-end relay with transfer-trip capability, 3) a receiving-end relay, and 4) a receiving-end relay with transfer-trip capability. A sending-end relay with the transfer-trip feature may be used with a receiving-end relay without the transfer-trip feature and vice versa. The basic functions of the four types of SPA relays are outlined in the table below.

TABLE I  
FUNCTIONS OF THE SPA RELAYS

RELAY	SENDING END	RECEIVING END	TRANSFER TRIP CAPABILITY	UNDERCURRENT DETECTION	OVERCURRENT DETECTION	GROUND DETECTION
SPA11A	X			X	X	X
SPA11B	X		X	X	X	X
SPA12A		X		X		
SPA12B		X	X	X		

An open pilot wire will result in undercurrent detection; a shorted pilot wire will result in overcurrent detection, and ground on either conductor of the pilot wire will result in ground detection.

**RATINGS**

TEMPERATURE

These relays have been designed for continuous operation in ambient temperatures between -20°C and + 55°C per ANSI Standard C37.90-1978. Over this range, the detection levels will vary by not more than three percent (3%) from their nominal values at 20°C.

In addition, these relays will not malfunction nor be damaged if operated in an ambient up to 65°C.

DIELECTRIC STRENGTH (AC HIGH-POTENTIAL TEST)

For the purposes of dielectric tests, the SPA relays are rated 600 volts. Per ANSI/IEEE C37.90-1978, the high-potential test voltage is 2200 volts AC for one minute. As described in the standard, relays other than new should be tested at 75% of this voltage.

CONTACTS

The telephone-relay output contacts in the SPA will make and carry 30 amperes for tripping duty and will make and carry 3 amperes continuously. The interrupting ratings are given in Table II.

TABLE II

INTERRUPTING CURRENT RATINGS OF TELEPHONE-TYPE RELAY CONTACTS

AC VOLTS	AMPS	
	INDUCTIVE †	NON-INDUCTIVE
115	0.75	2.0
230	0.5	1.5
<u>DC VOLTS</u>		
48	1.0	3.0
125	0.5	1.5
250	0.25	1.0

† The inductive rating is based on an L/R ratio of 0.1 second.

**TARGET SEAL-IN UNIT**

The target seal-in unit connected to studs 1 and 11 in the SPA11B and SPA12B relays has the ratings and characteristics shown in Table III.

**TABLE III**

**RATINGS AND CHARACTERISTICS OF THE TARGET SEAL-IN UNIT**

	<u>TAP</u>	
	<u>0.2</u>	<u>2.0</u>
DC Resistance $\pm 10\%$ (Ohms)	7	0.13
Minimum Operating (Amperes)	0.2	2.0
Carry Continuously (Amperes)	0.3	3
Carry 30 Amps for (Seconds)	0.03	4
Carry 10 Amps for (Seconds)	0.25	30
60 Hz Impedance (Ohms)	52	0.53
Minimum Dropout (Amperes)	0.05	0.5

**SEISMIC CAPABILITY**

The Seismic Fragility Level exceeds 3.5g ZPA when tested using a biaxial multi-frequency input motion to produce a Required Response Spectrum in accordance with ANSI/IEEE C37.98-1978, Standard for Seismic Testing of Relays.

**CHARACTERISTICS**

**OPERATING PRINCIPLES**

The Type SPA relays are designed to detect an open pilot-wire, a shorted pilot wire, and a grounded pilot wire in a protective system using pilot-wire relays. Type SPD pilot-wire relays are covered by instruction book GEK-49794.

The Type SPA relays operate by circulating a small direct current of approximately 0.75 milliamperes through the pilot wire. The current is provided by the power supply of the sending-end monitoring relay (SPA11A or SPA11B). The receiving-end monitoring relay(s) (SPA12A or SPA12B) completes the circuit loop for the circulating current without adding or subtracting (sourcing or sinking) any current.

**OPEN PILOT WIRES**

The undercurrent units in the SPA relays are energized (or picked up) under normal operating conditions. When an open circuit of the pilot wire occurs, the current drops to zero and the undercurrent units in both receiving- and sending-end relays drop out and the UC LED indicators light. This is the extreme case of the undercurrent condition. The undercurrent units will drop out for the circulating currents indicated below.

TABLE IV

UNDERCURRENT DETECTION LEVELS

RELAY	ARRANGEMENT	UNDERCURRENT DETECTION
Sending End	2 Terminal	0.53 ma or less
Receiving End	2 Terminal	0.43 ma or less
Sending End	3 Terminal	0.53 ma or less
Receiving End	3 Terminal	0.21 ma or less

SHORTED PILOT WIRES

The overcurrent units in the SPA relays are normally de-energized (or dropped out). When a short circuit of the pilot wire occurs, the current increases significantly, causing the overcurrent unit in the sending-end relay to pick up, and causing the OC LED indicator to light. All the current circulates through the short circuit, thereby reducing the current at the receiving end(s) to zero. This is detected by the undercurrent unit in the receiving-end relay(s).

A short circuit is the extreme case of the overcurrent condition. The overcurrent unit of the sending-end relay will pick up for circulating currents of 1.35 milliamperes or greater.

GROUNDING PILOT WIRES

When the resistance-to-ground of either conductor of the pilot wire falls below 10,000 ohms, the ground unit on the sending-end relay (normally dropped out) will pick up and the GND indicator LED will light.

REVERSED PILOT WIRES

In the event that the conductors of the pilot wire are accidentally reversed, the circulating current is shunted through a low-resistance path in the receiving-end relay. This results in overcurrent detection by the sending-end relay and undercurrent detection by the receiving-end relay. This condition is the same as in the case of shorted pilot wires.

OPERATING TIMES

The operating times of the undercurrent, overcurrent and ground detection circuits were intentionally made slow in order to override transient disturbances. The operating times vary, depending upon conditions on the primary system, application arrangements (e.g., two terminals versus three terminals), and the extent of the abnormal condition on the pilot wire. The values in Table V are approximate. They are intended to give a general idea of the time involved.

TABLE V

APPROXIMATE OPERATING TIMES

UNIT	PILOT WIRE CONDITION	DETECTION TIME †	RESTORE TIME ††
UC	Open Circuit	300 msec.	2000 msec.
OC	Short Circuit	300 msec.	700 to 2000 msec.
GND	Grounded Conductor	300 to 500 msec.	400 to 800 msec.

† Detection time of each function is the time to close its contact upon the occurrence of the condition listed in the table.

†† Restore time for each function is the time to reopen its contact when the condition listed in the table is removed and normal circuit conditions are restored.

TRANSFER TRIP

The SPA11B and SPA12B relays can send a transfer-trip signal over the pilot wire to initiate tripping at the other terminal(s). The signal can be sent from either the sending-end relay (SPA11B) or the receiving-end relay (SPA12B). It will initiate the tripping of both the local and remote breakers on a two-terminal line, or of all three breakers on a three-terminal line.

The transfer-trip signal is produced by energizing the coil of the TTA unit through an external contact. When the TTA picks up, it reverses the polarity of the DC voltage applied to the pilot wire through studs 7 and 8. The reversed-polarity voltage on the pilot wire causes the operation of the transfer-trip (TT) unit in the local and remote SPA relays. The TT output contact connected between studs 1 and 11 is provided with a target seal-in unit and is recommended for tripping duty. The TT contact between studs 2 and 3 is an auxiliary contact and has no target seal-in unit.

The operating time between energizing TTA at one end of the pilot wire and picking up TT at the other end (remote) varies slightly with the length of the pilot wire, as indicated below. The time to pick up the local unit is approximately two (2) cycles, independent of the length of the pilot wire.

	Remote TT Pickup Time (60 Hertz Basis)	Remote TT Dropout Time (60 Hertz Basis)
Short Pilot Wire (Series R = 0 ohm)	approximately 4 cycles	approximately 6 cycles
Long Pilot Wire (Series R = 2000 ohms)	approximately 5 cycles	approximately 6 cycles

If the pilot wire is to be used only for the transfer trip function and no pilot-wire-differential relays are connected to the pilot wire, the operating time will be as follows:

Remote TT Pickup Time (60 Hertz Basis)	
Short Pilot Wire	approximately 2 cycles
Long Pilot Wire	approximately 3 cycles

The transfer-trip operating time is virtually independent of station battery voltage for two reasons: 1) the TT units are energized from the regulated 12 volt power supply in the relay; and 2) the operating time of the TTA units varies only slightly with battery voltage, as shown in Fig. 12.

**LOW PASS FILTER**

The current circulating through the pilot wire is monitored through a low-pass filter in each of the SPA relays. The filter serves two purposes: 1) it screens out the AC signals transmitted over the pilot wire by the SPD relays; and 2) it screens out any AC disturbances or "noise" on the pilot wire. Relay models are available for use on 50 hertz systems and 60 hertz systems. The filters are slightly different, to ensure adequate attenuation at the system frequency.

**BURDENS**

The table below indicates the burdens of the SPA relays on the DC station supply under normal operating conditions.

TABLE VI

DC BURDENS

	48 V	110 V	125 V	WITH TTA ENERGIZED		
				48 V	110 V	125 V
SPA 11A	60 ma	25 ma	30 ma	-	-	-
SPA 11B	60 ma	25 ma	30 ma	150 ma	80 ma	90 ma
SPA 12A	60 ma	25 ma	30 ma	-	-	-
SPA 12B	60 ma	25 ma	30 ma	150 ma	80 ma	90 ma

Values may vary by up to 30%

**SETTINGS**

The SPA relays were designed and are factory tested such that calibration by the user is unnecessary. There are no adjustments to be made.

The power supplies within the relay must be set by the user to correspond with the DC input voltage. This entails the positioning of two adjacent selectors on the printed-circuit board that contains the power supply. The positions are clearly labeled on the printed-circuit board. The relays that include the transfer trip feature (SPA 11B and 12B) contain an additional voltage link to be set. It is located above the target seal-in unit on the mounting plate.

The receiving-end relays (SPA12A and SPA12B) must be set for a two-terminal application or a three-terminal application. This entails the positioning of a selector on the printed-circuit board.

The target seal-in unit tap setting should satisfy the following two requirements: 1) the minimum trip-circuit current should be enough to operate the target seal-in (at least 150% of tap is recommended); and 2) the target seal-in unit resistance on the tap chosen must be low enough so that the required trip current will flow.

## CONSTRUCTION

The Type SPA relays are assembled in the small-size, double-ended (S2) drawout case having studs at both top and bottom ends in the rear for external connections. The electrical connections between the relay and case studs are through stationary molded inner and outer blocks, between which nests a removable connection plug. The outer blocks attached to the case have the studs for the external connections, and the inner blocks have the terminals for the internal connections.

The four types of SPA relays have the same nameplate, which is shown in Figure 14. There are two cutouts for the LED indicators and the selector pins. One set of selector pins sets the DC voltage rating, and the other selector pin sets the relay for two- or three-terminal line applications. The labels between the cutouts are identical for all four types of SPA relays. The sending-end relays (SPA11A and 11B) have no selector pin to set the relay for two- or three-terminal applications, and the receiving-end relays (SPA12A and 12B) have no OC and GND indicator LEDs.

Every circuit in the drawout case has an auxiliary brush, as shown in Figure 13, to provide adequate overlap when the connecting plug is withdrawn or inserted. Some circuits are equipped with shorting bars (see internal connections in Figures 1, 2, 3, and 4).

The relay mechanism is mounted in a steel framework called the cradle, and is a complete unit with all leads terminated at the inner blocks. This cradle is held firmly in the case with a latch at both top and bottom. The connection plug, besides making the electrical connections between the respective blocks of the cradle and case, also locks the latch in place. The cover, which is drawn to the case by thumbscrews, holds the connection plugs in place. On the relays that include the transfer trip feature (SPA11B and SPA12B), the target-reset mechanism is a part of the cover assembly.

The relay case is suitable for either semiflush or surface mounting on all panels up to two inches thick, and appropriate hardware is available. The relay is shipped with hardware suitable for mounting on 1/8 inch steel panels. Panel thickness, if other than 1/8 inch, must be indicated on the relay order to ensure that proper hardware will be included. Outline and panel drilling is shown in Figure 11.

A separate testing plug can be inserted in place of the connection plug to test the relay in place on the panel, either from its own source of current and voltage, or from other sources; or the relay can be drawn out and replaced by another that has been tested in the laboratory.

Figure 14 is a labeled photograph of an SPA11B relay. With the exception of the printed circuit boards, the other SPA relays have the same construction, with parts as indicated in Table VII. Surge capacitors are not included in Table VII (refer to the internal connections diagrams, Fig. 1 through 4).

TABLE VII

CONSTRUCTION VARIATIONS

RELAY	TRANSFER TRIP PARTS†	OC UNIT	UC UNIT	GND UNIT	GND REACTOR
SPA11A		X	X	X	X
SPA11B	X	X	X	X	X
SPA12A			X		
SPA12B	X		X		

†Transfer Trip Parts:

- TT Unit
- Target Seal-in Unit
- TTA Unit
- DC Voltage Volt Link
- R8 - 150 Ohm Resistor
- R93 - 1000 Ohm Resistor
- R94 - 1000 Ohm Resistor
- R95 - MOV

There are six different printed-circuit boards used in the four SPA relays as indicated in Table VIII. The sending-end relays, SPA11A and 11B, each contain two printed-circuit boards and the receiving-end relays, SPA12A and 12B, each contain one printed-circuit board. For later model SPA relays (identified by a "Rev.A" following the model number) there is a new PCB-1, power supply and detection board. The following tables indicate board positions for the original and "Rev.A" models. The internal-connection diagrams for the printed-circuit boards are shown in Figures 5 through 10.

TABLE VIII-A

PRINTED CIRCUIT BOARD INFORMATION

Original Models

RELAY: PC Board	PCB ASSEMBLY NUMBER	Hz 50/60	FRONT VIEW POSITION	LED INDICATORS	TRANSFER TRIP CIRCUITRY
SPA11A: PCB-1	0184B8614	G2/G1	Left Slot	(1) Power Supply (Yellow)	NO
SPA11A: PCB-2	0184B8617	G2/G1	Right Slot	(3) UC, OC, GND (All Red)	NO
SPA11B: PCB-1	0184B8612	G2/G1	Left Slot	(1) Power Supply (Yellow)	YES
SPA11B: PCB-2	0184B8616	G2/G1	Right Slot	(3) UC, OC, GND (All Red)	YES
SPA12A: PCB-1	0184B8615	G2/G1	Right Slot	(2) Power Supply (Yellow), UC (Red)	NO
SPA12B: PCB-1	0184B8613	G2/G1	Right Slot	(2) Power Supply (Yellow), UC (Red)	YES

TABLE VIII-B

PRINTED CIRCUIT BOARD INFORMATION  
SPA MODELS IDENTIFIED AS "REV.A"

RELAY: PC BOARD	PCB ASSEMBLY NUMBER	HZ 50/60	FRONT VIEW POSITION	LED INDICATORS	TRANSFER TRIP CIRCUITRY
SPA11A: PCB-1	0184B8730	G2/G1	Left Slot	(1) Power Supply (Yellow)	NO
SPA11A: PCB-2	0184B8617	G2/G1	Right Slot	(3) UC, OC, GND (All Red)	NO
SPA11B: PCB-1	0184B8730	G4/G3	Left Slot	(1) Power Supply (Yellow)	YES
SPA11B: PCB-2	0184B8616	G2/G1	Right Slot	(3) UC, OC, GND (All Red)	YES
SPA12A: PCB-1	0184B8730	G6/G5	Right Slot	(2) Power Supply (Yellow), UC (Red)	NO
SPA12B: PCB-1	0184B8730	G8/G7	Right Slot	(2) Power Supply (Yellow), UC (Red)	YES

**RECEIVING, HANDLING AND STORAGE**

These relays, when not included as part of a control panel, will be shipped in cartons designed to protect them against damage. Immediately upon receipt of a relay, examine it for any damage sustained in transit. If injury or damage resulting from rough handling is evident, file a damage claim at once with the transportation company and promptly notify the nearest General Electric Sales Office. When the relay is received, check the nameplate stamping to make sure that the model number and rating of the relay agree with the requisition.

Reasonable care should be exercised in unpacking the relay in order that none of the parts are injured or the adjustments disturbed.

If the relays are not to be installed immediately, they should be stored in their original cartons in a place that is free from moisture, dust and metallic chips. Foreign matter collected on the outside of the case may find its way inside when the cover is removed, and cause trouble in the operation of the relay.

**ACCEPTANCE TESTS**

Immediately upon receipt of the relay an inspection and acceptance test should be made to make sure that no damage has been sustained in shipment.

These tests may be performed as part of the installation, or as acceptance tests or both, at the discretion of the user.

## VISUAL INSPECTION

Check the nameplate stamping to make sure that the model number and rating of the relay agree with the requisition. Check that the model number on the label in the back of the case agrees with the nameplate.

Remove the relay from its case and check that there are no broken or cracked molded parts or other signs of physical damage, and that all screws are tight.

## MECHANICAL INSPECTION

### Cradle and Case Blocks

Check that the fingers on the cradle and the case agree with the internal connection diagram. Each cradle finger should be flush or project above the barrier between fingers. Check that there is a coil spring under each finger. The case fingers, if not held down by a shorting bar, should come within one-sixteenth (1/16) of an inch of touching a straight edge bridging the case block from side to side. If a finger is held down by a shorting bar, it should require at least one pound of force (450 grams) to open the electrical circuit between the finger and the shorting bar. See Figure 13. Check that each auxiliary brush extends above the barrier between fingers.

### Target Seal-in Unit (SPA11B and 12B)

Pick up the armature by hand. The orange target should appear. When the armature is released, the target should remain in view. Push in on the reset arm. The target should drop from view.

Hold the armature up by hand. The target should not be at the end of its travel. Verify this by reaching in one of the windows of the target with a sharp instrument, such as a knife or scribe, and pushing upward. The target should move definitely upward (at least one sixty-fourth of an inch, or 0.4 millimeter). Release the armature. The target should fall visibly downward (at least 0.010 inch or 1/4 millimeter) before the target is caught by the latch.

### Telephone Relays

Observe each telephone relay in the de-energized position. Check that each normally open contact has a gap spacing of at least 0.010 inch or 0.25 millimeter. Check that each normally-closed contact has a contact pressure of at least five grams (5g) by deflecting the stationary contact away from the moving contact with a force gage.

Operate each telephone relay by pressing on the armature. In the operated position, check that each normally closed contact has at least 0.010 inch (0.25 millimeter) gap. Check that each normally open contact has at least 0.005 inch (0.13 millimeter) of overtravel after contact, by observing that the contact still closes with a 0.0025 inch (0.06 millimeter) shim inserted between the armature and pole piece.

## ELECTRICAL INSPECTION

The correct operation of the contacts may be verified by manually operating the telephone relays and monitoring the contacts with an ohmmeter.

250 DC Rating

The 250 DC rating is accomplished with an external pre-regulator, 0138B7511G2 and G3. The pre-regulator is a DC-to-DC Converter that reduces the 250 VDC station voltage to the 125 VDC rating of the SPA relay. Therefore, when this pre-regulator is used, the SPA relay DC pins on the 125 volt position.

The pre-regulator is designed to be mounted on the panel next to the relay.

The electrical connections for the pre-regulator are made as follows:

INPUT	PRE-REGULATOR TERMINAL	OUTPUT	PRE-REGULATOR TERMINAL	TO SPA RELAY TERMINAL
+ 250 VDC	A	+ 125 VDC	B	4
- DC	C	- DC	C	5

Sending End

**Undercurrent Detection (SPA11A and 11B)**

Refer to test plug connection diagram, Figure 15.

Apply DC power to studs 4 (positive) (+) and 5 (negative) (-). Be sure that the power supply selector pins on printed-circuit board #1 (left hand board) are set properly for the DC voltage being used. It is necessary to remove the nameplate and card guide to reposition the selector pins.

Connect a 39,000 ohm external resistor (rated 1/4 watt) between studs 7 and 8. The UC telephone relay should drop out and the UC indicator LED should light. Replace the resistor with a 20,000 ohm resistor. The UC telephone relay should be picked up and the UC indicator LED should be off.

**Overcurrent Detection (SPA11A and 11B)**

Refer to test plug connection diagram, Figure 15.

Repeat the undercurrent test using the following resistors:

With 6,200 ohms (1/4 watt), the OC telephone relay should pick up and the OC LED should light. With 13,000 ohms, the OC telephone relay should be dropped out and the OC indicator LED should be off.

**Ground Detection (SPA11A and 11B)**

Refer to test plug connection diagram, Figure 16.

Apply DC power to studs 4 (positive) (+) and 5 (negative) (-). Connect a 10,000 ohm external resistor (rated 1/4 watt) between studs 7 and 16. The GND telephone relay should pick up and the GND indicator LED should light.

**Transfer Trip (SPA11B)**

Refer to test plug connection diagram, Figure 17.

Connect a 24,000 ohm external resistor (rated 1/4 watt) between studs 7 and 8. Be sure that the DC voltage link above the target seal-in unit is in the proper position. Apply 75% of rated voltage to studs 4 (positive) (+) and 5 (negative) (-) and to studs 19 (positive) (+) and 20 (negative) (-). Verify that the TTA and TT telephone relays pick up.

### Receiving End

#### Undercurrent Detection (SPA12A and 12B)

Refer to test plug connections diagram, Figure 18.

Apply dc power to studs 4 (positive) (+) and 5 (negative) (-). Be sure that the power-supply selector pins on the printed-circuit board are set properly for the DC voltage being used. Set the two- or three-terminal selector pin on the printed-circuit board in the two-terminal position. Connect a 24 volt DC power supply in series with a 30,000 ohm resistor (rated 1/4 watt) between studs 7 (positive) (+) and 8 (negative) (-). The UC telephone relay should drop out and the UC indicator LED should light. Replace the resistor with a 10,000 ohm resistor. The UC telephone relay should be picked up and the UC indicator LED should be off.

Set the two or three-terminal selector pin in the three-terminal position. Repeat the above tests using a 62,000 ohm resistor (UC LED should light) and a 30,000 ohm resistor (UC LED should be off).

#### Transfer Trip (SPA 12B)

Refer to test plug connection diagram, Figure 19.

Connect a 24 volt DC supply in series with an 11,000 ohm resistor (rated 1/4 watt) between studs 7 (positive) (+) and 8 (negative) (-). Be sure that the DC voltage link above the target seal-in unit is in the proper position. Apply 75% of rated voltage to studs 4 (positive) (+) and 5 (negative) (-) and to studs 19 (positive) (+) and 20 (negative) (-). Verify that the TTA and TT telephone relays pick up

### DIELECTRIC TESTS (HIGH POTENTIAL TESTS)

#### Introduction

The surge capacitors (C24 through C41) used in the SPA relays do not have voltage ratings to withstand AC hipot voltage; therefore, caution must be exercised when hipotting, to avoid damaging these capacitors.

It is recommended that hipot tests be performed on a bench with the relay in its case. If the relay is to be hipot tested together with other apparatus in an equipment, all **external connections to terminals 6 and 16 (surge ground) must be removed.**

The hipot test should be 2200 volts rms, 50 or 60 hertz for new relays or 1650 volts rms, 50 or 60 hertz for other relays. New relays are defined as those that have not been in service, which are not more than one year old from the date of shipment, and that have been suitably stored to prevent deterioration. The duration of application of the test voltage for both new and old relays should be 60 seconds.

Hipot Tests

- a) Remove internal connection from surge capacitor buses to surge ground terminals 6 and 16.
- b) Common Mode Hipot Tests (All terminals to case)

Temporary connections should be made to tie all relay terminals together. Hipot voltage can then be applied between this common connection and the relay case.

- c) Transverse Mode Hipot Tests (Between circuits)

For hipot tests between circuits of the relay, the surge capacitors must be temporarily disconnected from the surge capacitor buses inside the relay. Hipot voltage can then be applied between any two of the circuit groups indicated in Table IX. Where there is more than one terminal in a group, those terminals should be jumpered together.

An alternate test using a 500 DC Megger™ can be performed between the circuit groups of Table IX with the surge capacitors connected in their normal manner. While this method does not test the relay to its full dielectric rating, it will detect some cases of degraded insulation.

TABLE IX

CIRCUIT GROUPING FOR TRANSVERSE MODE HIPOT TESTS

RELAY	TERMINALS OF CIRCUIT GROUPS
SPA11A	a. 4,5 b. 7, 8 c. 9, 10 d. 12, 13 e. 14, 15 f. 17, 18
SPA11B	Same as SPA11A plus: g. 1, 11 h. 2, 3 i. 19, 20
SPA12A	a. 4,5 b. 7, 8 c. 9, 10 d. 12, 13
SPA12B	Same as SPA12A plus: e. 1, 11 f. 2, 3 g. 19, 20

**RESTORING RELAY TO SERVICE**

After the hipot testing is completed, the surge capacitors should be reconnected to the surge capacitor buses, the surge capacitor buses reconnected to studs 6 and 16, and all external wiring to terminals 6 and 16 (surge ground) should be reconnected.

**INSTALLATION PROCEDURE**

Mount the relay vertically in a clean, dry and well lighted place to allow accessibility for cleaning, inspection and testing, and where it will not be subjected to excessive vibration or heat. Unless mounted on a steel panel that adequately grounds the relay case, the case should be grounded through a mounting stud or mounting screw with a conductor not less than #12 AWG copper wire or its equivalent. It may be necessary to remove paint from the case at the point of connection to ensure reliable contact.

Terminal 6 (bottom surge ground) should be connected to the lower case-mounting stud and terminal 16 (top surge ground) should be connected to the upper case-mounting stud using #12 AWG copper wire. Also, terminals 6 and 16 should be tied together with #12 AWG copper wire to insure adequate grounding (see external jumpers in Figures 1 through 4).

Check the nameplate to be sure that the relay is the desired model number. The section on **ACCEPTANCE TESTS** contains all the tests that the user, at his discretion, may want to perform as part of the installation procedure.

**SETTING THE TAP OF THE TARGET SEAL-IN UNIT (SPA11B and 12B)**

The contact adjustment will not be disturbed if the following procedure is followed when changing the tap. Take either one of the two screws from the left contact plate and transfer it to the desired tap position in the right tap plate. Then remove the screw from the undesired tap position in the right tap plate and transfer it to the vacant location in the left contact plate. Do not leave the unit with screws in both the tap locations of the right plate.

**SUPPLY VOLTAGE SETTING**

Be sure to set the two selector pins on the printed circuit containing the power supply (left-hand board in the sending-end relays, only board in the receiving end relays) to correspond with the station battery voltage. For SPA relays with REV A on the nameplate there is only one power-selection link to set. Place in the setting corresponding to the station battery. For the SPA11B and 12B, which contain the transfer-trip feature, it is also necessary to set a link above the target seal-in unit.

**TERMINAL ARRANGEMENT SETTING**

The SPA12A and 12B receiving-end relays are to be set for either a two- or a three-terminal arrangement. This is accomplished by positioning a selector pin on the printed circuit board. The positions are clearly labeled on the board.

**PERIODIC CHECKS AND ROUTINE MAINTENANCE**

**WARNING:** HIGH VOLTAGES MAY APPEAR ON PILOT WIRES UNEXPECTEDLY AT ANY TIME. USE APPROPRIATE CARE WHEN MAKING CONTACT WITH PILOT WIRES OR EQUIPMENT CONNECTED TO THEM

The pilot wire protective equipment, if installed, is designed to limit the pilot-wire voltages to a level that will not damage the wires or equipment connected to them. It does not limit the voltages to a level that is safe for unprotected personnel contacting the pilot wires or connected equipment. **THEREFORE, USE APPROPRIATE CARE WHEN MAKING CONTACT WITH PILOT WIRES, EVEN WHEN THE PILOT-WIRE PROTECTIVE EQUIPMENT IS IN PLACE.**

In view of the vital role of protective relays in the operation of a power system, it is important that a periodic test program be followed. It is recognized that the interval between periodic checks will vary depending upon environment, type of relay and the user's experience with periodic testing. Until the user has accumulated enough experience to select the test interval best suited to his individual requirements, it is suggested that the points listed under **ACCEPTANCE TESTS** be checked at an interval of from one to two years.

Check the items described under **ACCEPTANCE TESTS - VISUAL INSPECTION AND MECHANICAL INSPECTION**. Examine each component for signs of overheating, deterioration or other damage. Check that all connections are tight by observing that the lockwashers are fully collapsed.

**CONTACTS**

Examine the contacts for pits, arc or burn marks, corrosion, and insulating films. For cleaning contacts, a flexible burnishing tool should be used. This consists of a flexible strip of metal with an etch-roughened surface, resembling in effect, a superfine file. The polishing action is so delicate that no scratches are left, yet any corrosion is thoroughly and rapidly cleaned. The flexibility of the tool ensures the cleaning of the actual points of contact. Do not use knives, files, abrasive paper or cloth of any kind to clean relay contacts.

**ELECTRICAL TESTS**

The tests described in the electrical inspection of the **ACCEPTANCE TESTS** suffice as periodic checks for the SPA relays. Refer to Figures 15 through 19 for the test plug connections.

If a relays fails to pass one or more of these tests, it requires servicing.

## SERVICING

**CAUTION:**

**ALL power from the relay before removing or inserting any of the printed-circuit boards. Failure to observe this caution may result in damage to and/or misoperation of the relay.**

Telephone Relays

Adjustment of telephone relays requires skill and experience for best results. The following guidelines may be of assistance. Increasing the stroke of the moving spring will raise pickup, as will decreasing normally-closed contact overtravel. Increasing normally-open contact overtravel or increasing residual gap will increase dropout. After adjusting, be sure to check gaps and overtravels and readjust if necessary to keep them above their minimum values.

Target Seal-in Unit

**As readjustment of the target seal-in unit may affect the Seismic Fragility Level, it is advised that no mechanical adjustments be made if seismic capability is of concern.**

The two moving contacts should be horizontal and both should meet the stationary contacts together. There should be approximately one sixty-fourth inch (0.4 millimeter) gap between the armature and the pole piece when the contacts touch. Adjust the stationary contact positions if required to obtain these conditions.

Using well-filtered direct current (DC), check the pickup and dropout current and compare the values to those given in **RATINGS**. If necessary, adjust the spring tension and contact overtravel.

**RENEWAL PARTS**

It is recommended that sufficient quantities of renewal parts be carried in stock to enable the prompt replacement of any that are worn, broken or damaged.

Should a printed-circuit card become inoperative, it is recommended that this card be replaced with a spare. In most instances, the user will be anxious to return the equipment to service as soon as possible and the insertion of a spare card represents the most expeditious means of accomplishing this. The faulty card can then be returned to the factory for repair or replacement.

Although it is not generally recommended, it is possible, with the proper equipment and trained personnel, to repair cards in the field. This means that a troubleshooting program must isolate the specific component on the card that has failed. By referring to the internal-connection diagram for the card, it is possible to trace through the card circuit by signal checking and, hence determine which component has failed. This, however, may be time consuming and if the card is being checked in place in its unit, as is recommended, will extend the outage time of the equipment.

See Cautions, next page.

**CAUTION:**

Great care must be taken in replacing components on the cards. Special soldering equipment suitable for use on the delicate solid-state components must be used and, even then, care must be taken not to cause thermal damage to the components, and not to damage or bridge over the printed circuit buses. The repaired area must be coated with a suitable high-dielectric plastic coating to prevent possible breakdowns across the printed-circuit buses due to moisture or dust.

**ADDITIONAL CAUTION:**

Dual in-line integrated circuits are especially difficult to remove and replace without specialized equipment. Furthermore, many of these components are used on printed-circuit cards that have bus runs on both sides. These additional complications require very special soldering equipment and removal tools as well as additional skills and training, which must be considered before field repairs are attempted.

When ordering renewal parts, address the nearest Sales Office of the General Electric Company, specify quantity required, name of the part wanted, and the complete model number of the relay for which the part is required.

Since the last edition, Figures 20 and 21 have been revised.

LIST OF ILLUSTRATIONS

TITLES OF FIGURES

<u>Figure</u>	
1	Internal-Connections Diagram for Type SPA11A Relay
2	Internal-Connections Diagram for Type SPA11B Relay
3	Internal-Connections Diagram for Type SPA12A Relay
4	Internal-Connections Diagram for Type SPA12B Relay
5a	Internal Connections for printed circuit board in position PCB-1 in SPA11A (No rev. letter) Board Identity: : 0184B8614 G-
5b	Internal Connections for printed circuit board in position PCB-1 in SPA11A (Rev.A) Board Identity: 0184B8730 G-
6	Internal Connections for printed circuit board in position PCB-2 in SPA11A (both no rev.letter and Rev.A) Board Identity: 0184B8617 G-
7a	Internal Connections for printed circuit board in position PCB-1 in SPA11B (No rev. letter) Board Identity: 0184B8612 G-
7b	Internal Connections for printed circuit board in position PCB-1 in SPA11B (Rev.A) Board Identity: 0184B8730 G-
8	Internal Connections for printed circuit board in position PCB-2 in SPA11B (both no rev. letter and Rev.A) Board Identity: 0184B8616 G-
9a	Internal Connections for printed circuit board in position PCB-1 in SPA12A (No rev. letter) Board Identity: 0184B8615 G-
9b	Internal Connections for printed circuit board in position PCB-1 in SPA12A (Rev.A) Board Identity: 0184B8730 G-
10a	Internal Connections for printed circuit board in position PCB-1 in SPA12B (No rev. letter) Board Identity: 0184B8613 G-
10b	Internal Connections for printed circuit board in position PCB-1 in SPA12B (Rev.A) Board Identity: 0184B8730 G-
11	Outline and Panel Drilling
12	TTA Operating Time Versus Supply Voltage
13	Auxiliary Brush and Shorting Bar
14	Front View Photograph of SPA11B Relay with Nameplate Attached
15	Test-Plug Connections for SPA11A and 11B UC and OC Acceptance Test
16	Test-Plug Connections for SPA11A and 11B GND Acceptance Test
17	Test-Plug Connections for SPA11B Transfer-Trip Acceptance Test
18	Test-Plug Connections for SPA12A and 12B UC Acceptance Test
19	Test-Plug Connections for SPA12B Transfer-Trip Acceptance Test
20	Elementary System Diagram for Pilot-Wire Relaying for Two-Terminal Lines Using SPD11A, SPA11A and SPA12A Relays
21	Elementary System Diagram for Pilot-Wire Relaying for Three-Terminal Lines Using SPD11A, SPA11A and SPA12A Relays
22	Elementary System Diagram for Pilot-Wire Relaying and Two-Direction Transfer Trip on Two-Terminal Lines Using SPD11A, SPA11B and SPA12B Relays
23	Elementary System Diagram for Pilot-Wire Relaying and Two-Direction Transfer Trip on Three-Terminal Lines Using SPD11A, SPA11B and SPA12B Relays

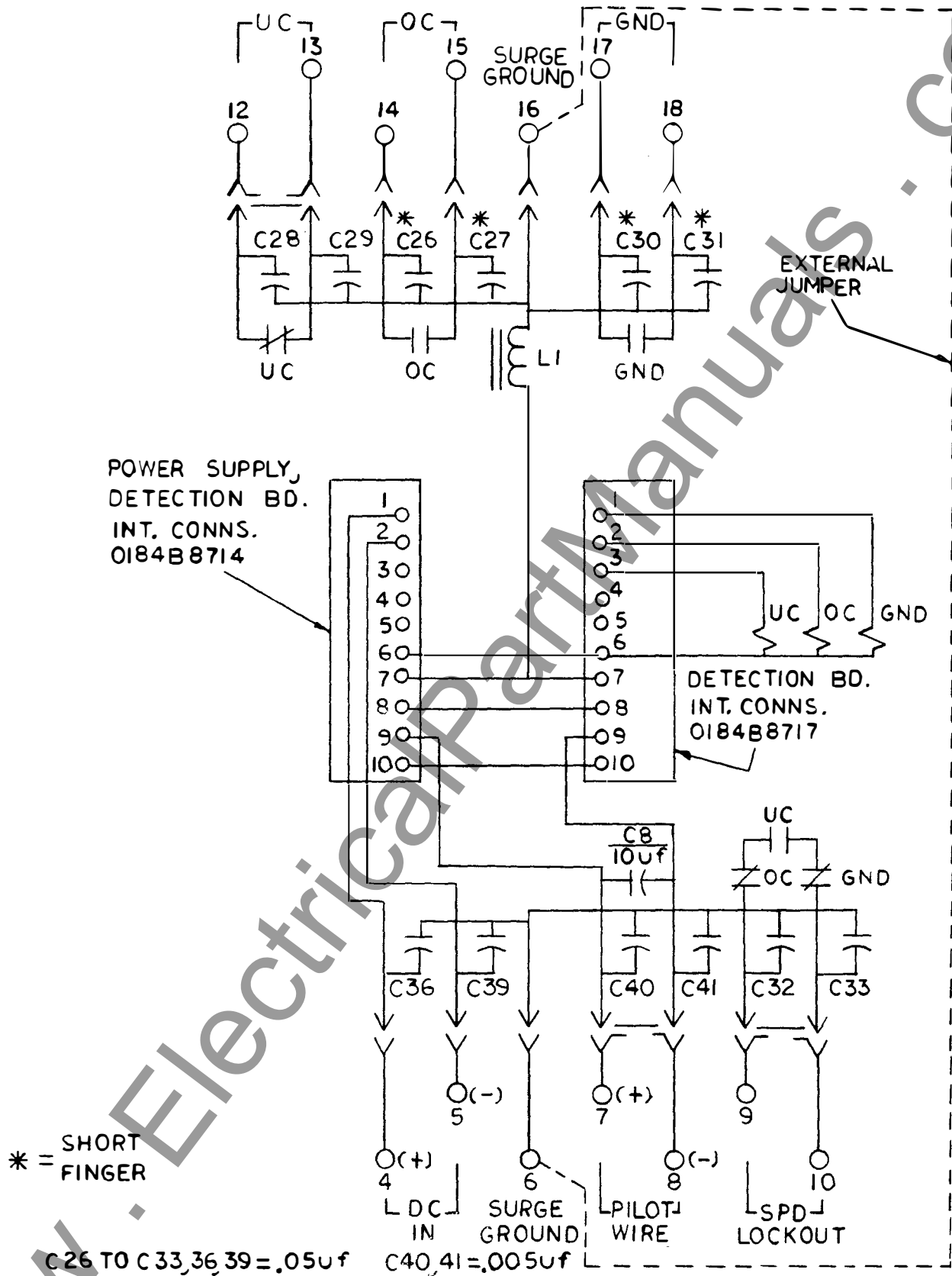

Figure 1 (0275A3240-0) Internal Connections Diagram for Type SPA11A Relay

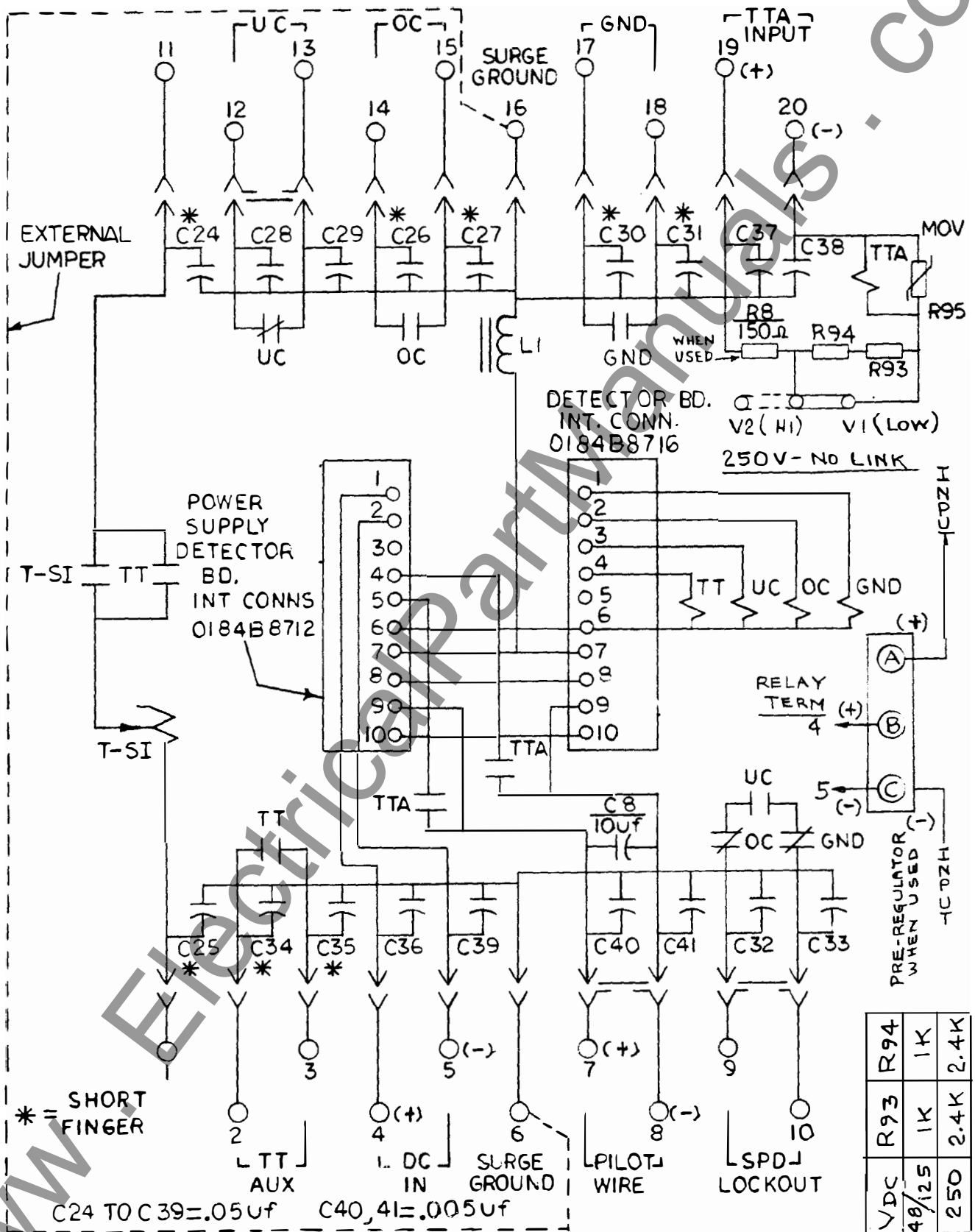

Figure 2 (0275A3241-3) Internal Connections Diagram for Type SPA11B Relay

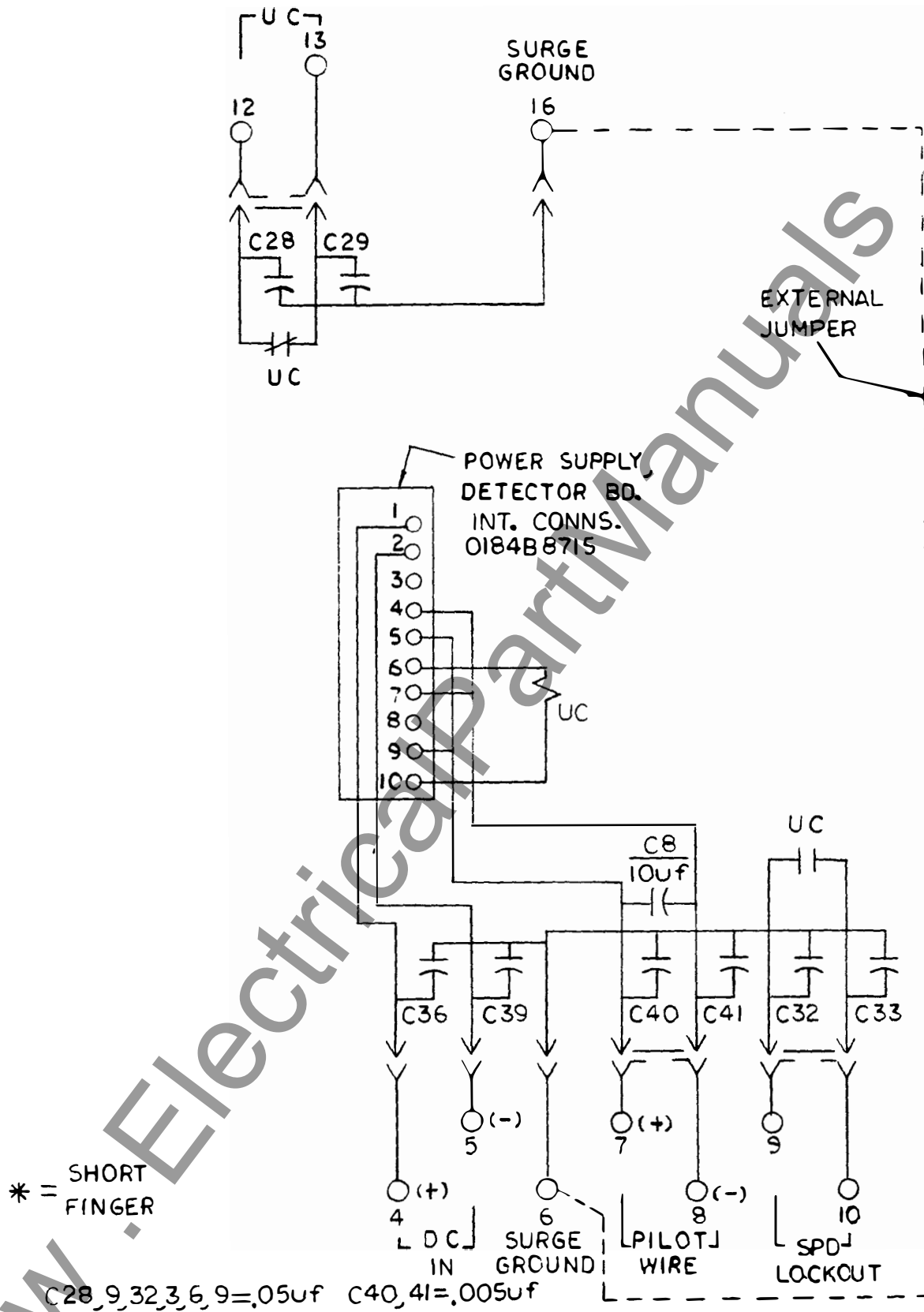

Figure 3 (0275A3242-0) Internal Connections Diagram for Type SPA12A Relay

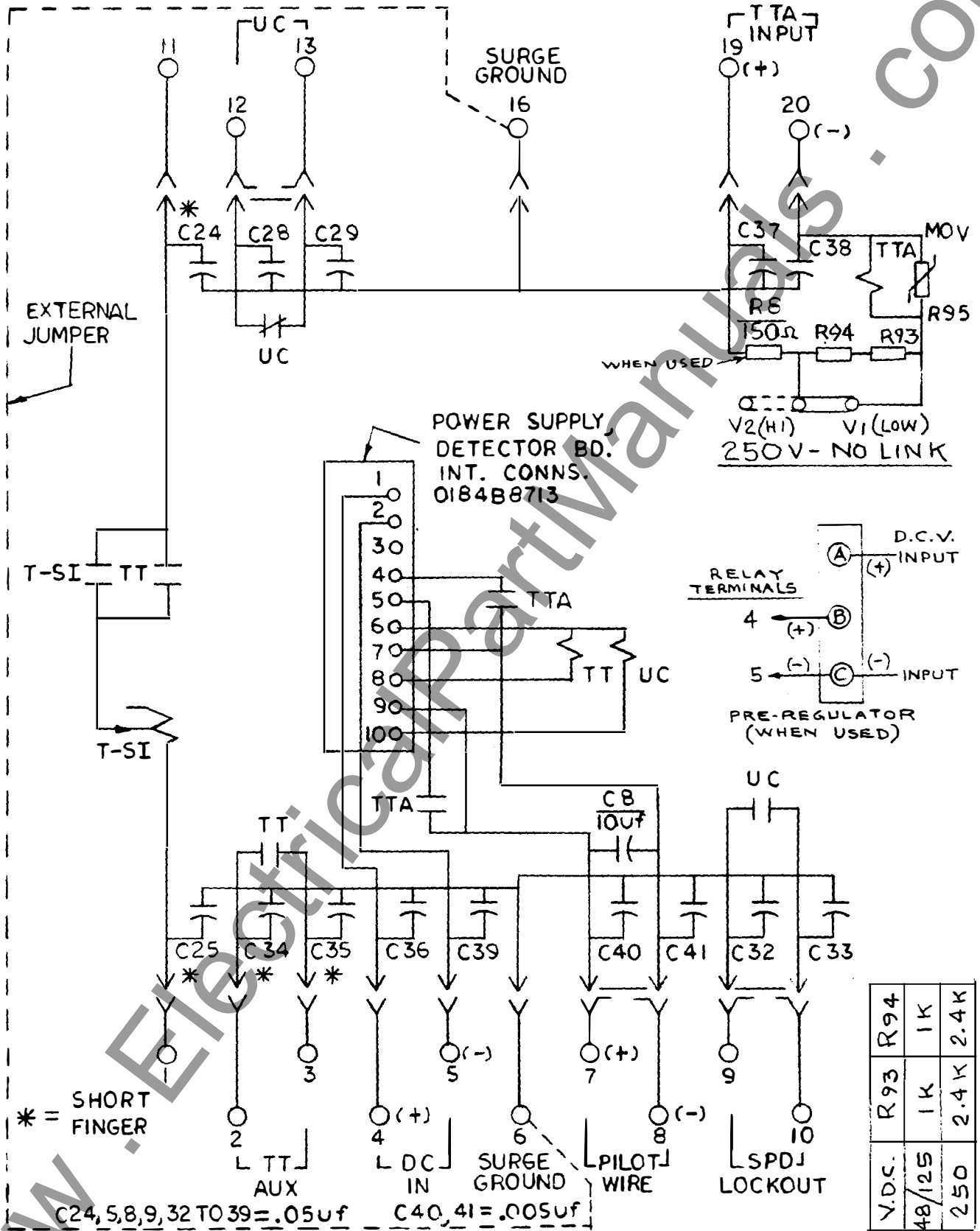
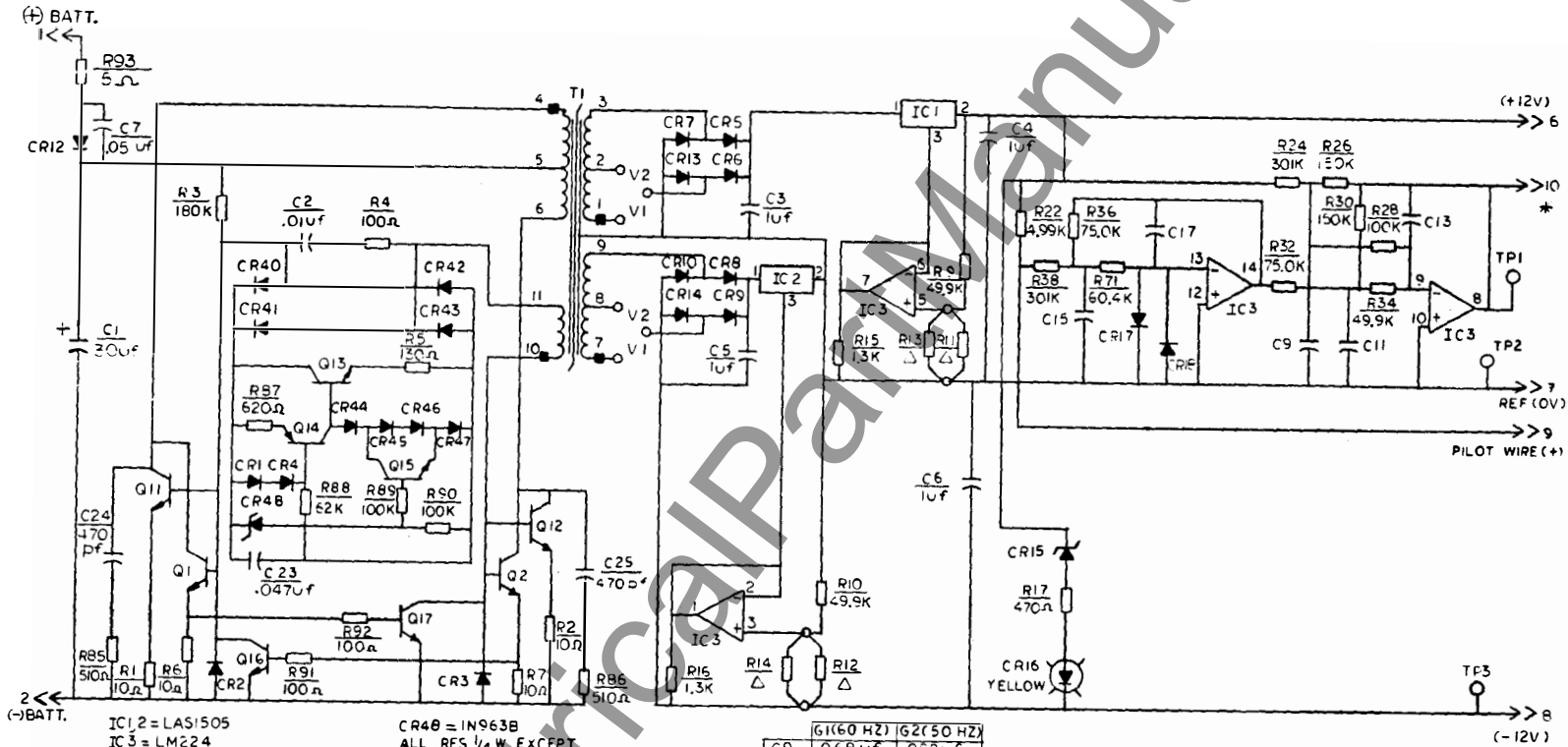

Figure 4 (0275A3243-3) Internal Connections Diagram for Type SPA12B Relay



IC1,2 = LAS1505  
 IC3 = LM224  
 Q1,2,11,12 = 2N3439  
 Q13,15-17 = 2N2222A  
 Q14 = 2N2507  
 CR1-10,13,14,17,18,40-47 = 1N4147  
 CR12 = 1N5061  
 CR15 = 1N555B

CR48 = 1N963B  
 ALL RES 1/4 W EXCEPT  
 R17 = 2W  
 R3 1/2 W  
 R95,86 = 1W  
 Δ = TRIM  
 IC3, PIN 4 = +V, PIN 11 = GND.

	G1(60 HZ)	G2(50 HZ)
C9	.068uF	.062uF
C11	.15uF	.18uF
C13	.047uF	.056uF
C15	.10uF	.12uF
C17	.047uF	.056uF
V1	48V	48V
V2	110-125V	110-125V

\* = CONNECT TO PIN 10 ON  
 P.C.B. NO.2 INT. CONNS.  
 0184B8717

Figure 5a (0184B8714-4) Internal Connections for Printed Circuit Board in Position PCB-1 in SPA11A (No rev. letter) Board Identity: : 0184B8614-G-

Figure 5b (0153D7688) Internal Connections for Printed Circuit Board in Position PCB-1 in SPA11A (Rev.A) Board Identity: 0184B8730 G-

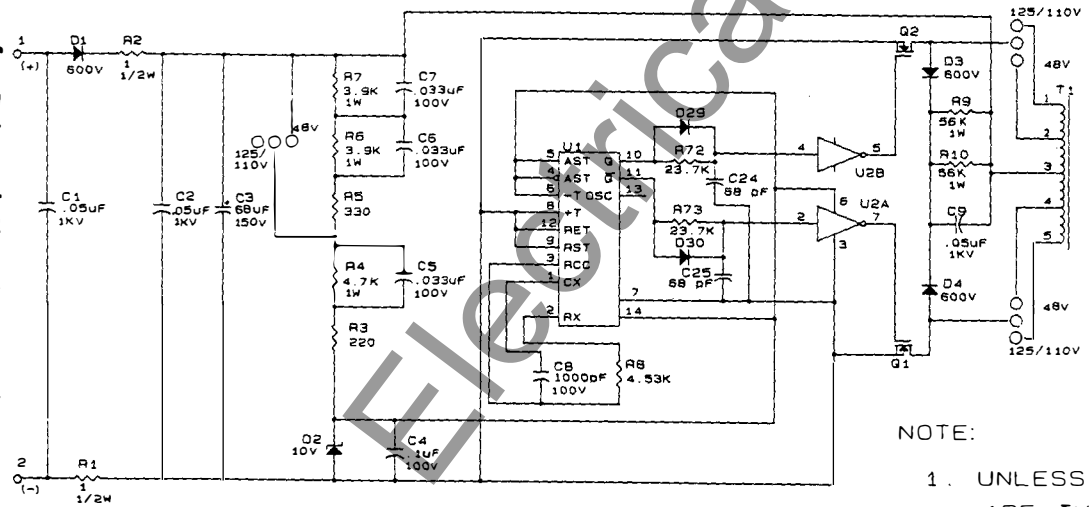
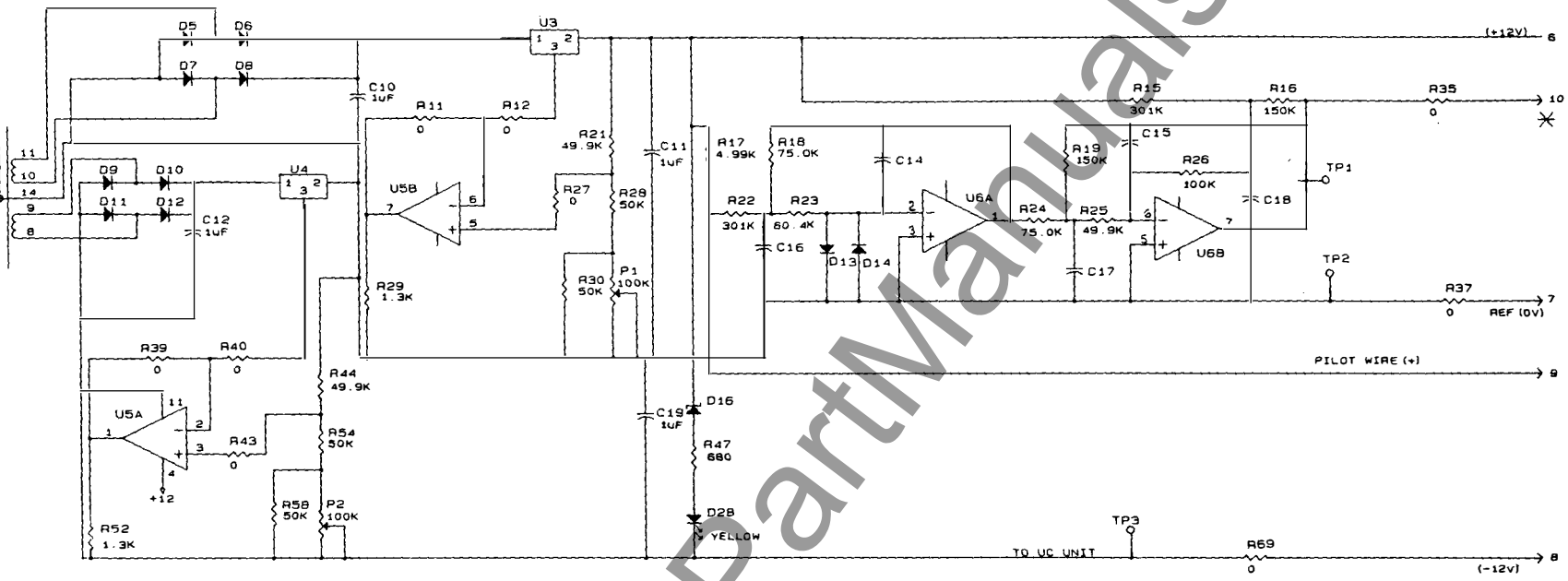

	G1	G2
C14	.047uF	.056uF
C15	.047uF	.056uF
C16	.10uF	.12uF
C17	.15uF	.18uF
C18	.068uF	.082uF

NOTE:

1. UNLESS OTHERWISE SPECIFIED ALL RESISTORS ARE IN OHMS AND ARE 1/4 W.
2. \* CONNECT TO PIN 10 ON PCB NO 2 INTERNAL CONNECTIONS 0184B8717

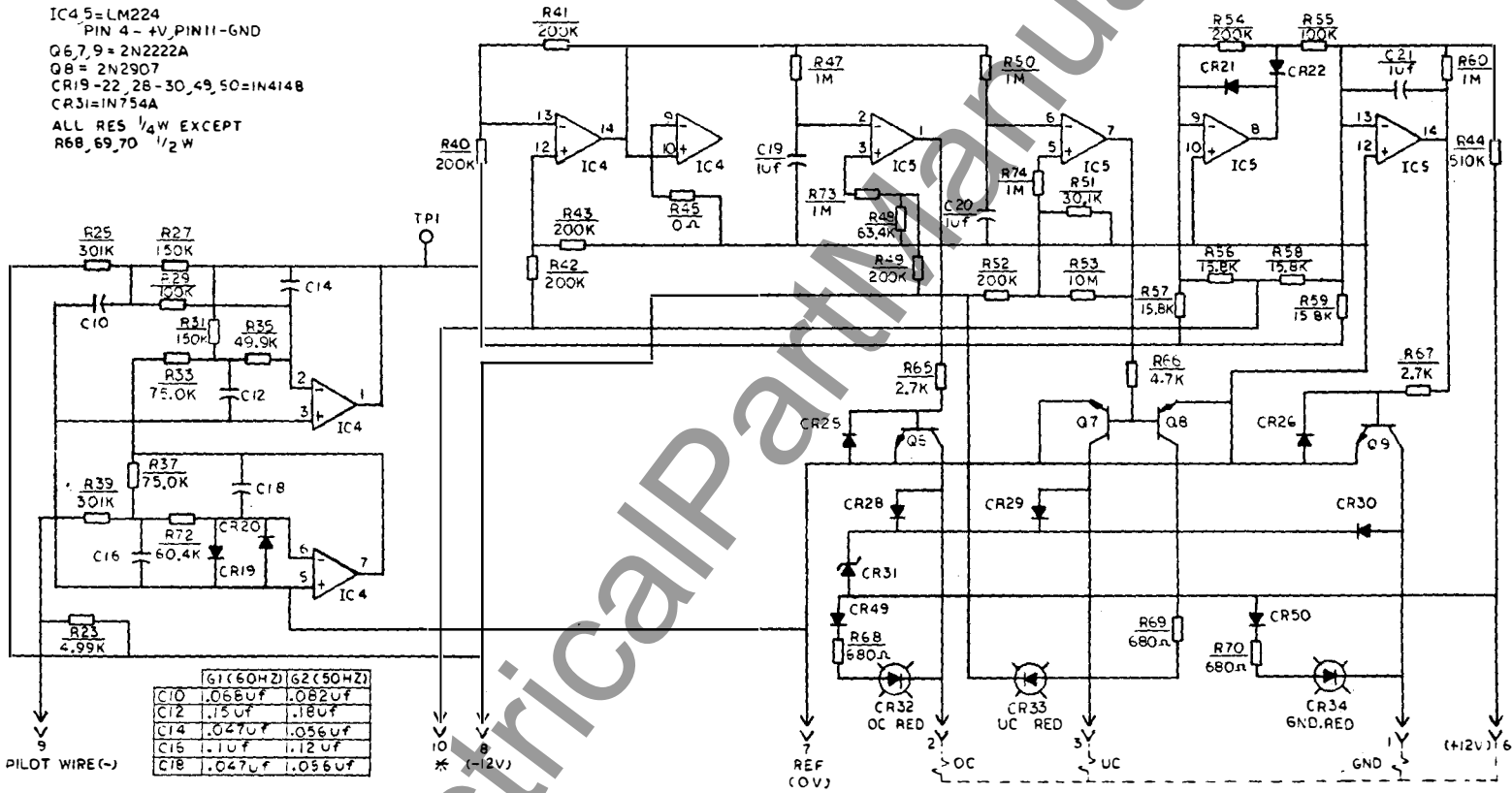

\* = CONNECTED TO PIN 10 ON  
 P.C.B. NO. 1 INT. CONNS.  
 0184B8714

Figure 6 (0184B8717-1) Internal Connections for Printed Circuit Board  
 in Position PCB-2 in SPA11A (both no Rev.letter and Rev.A) Board Identity: 0184B8617 G-

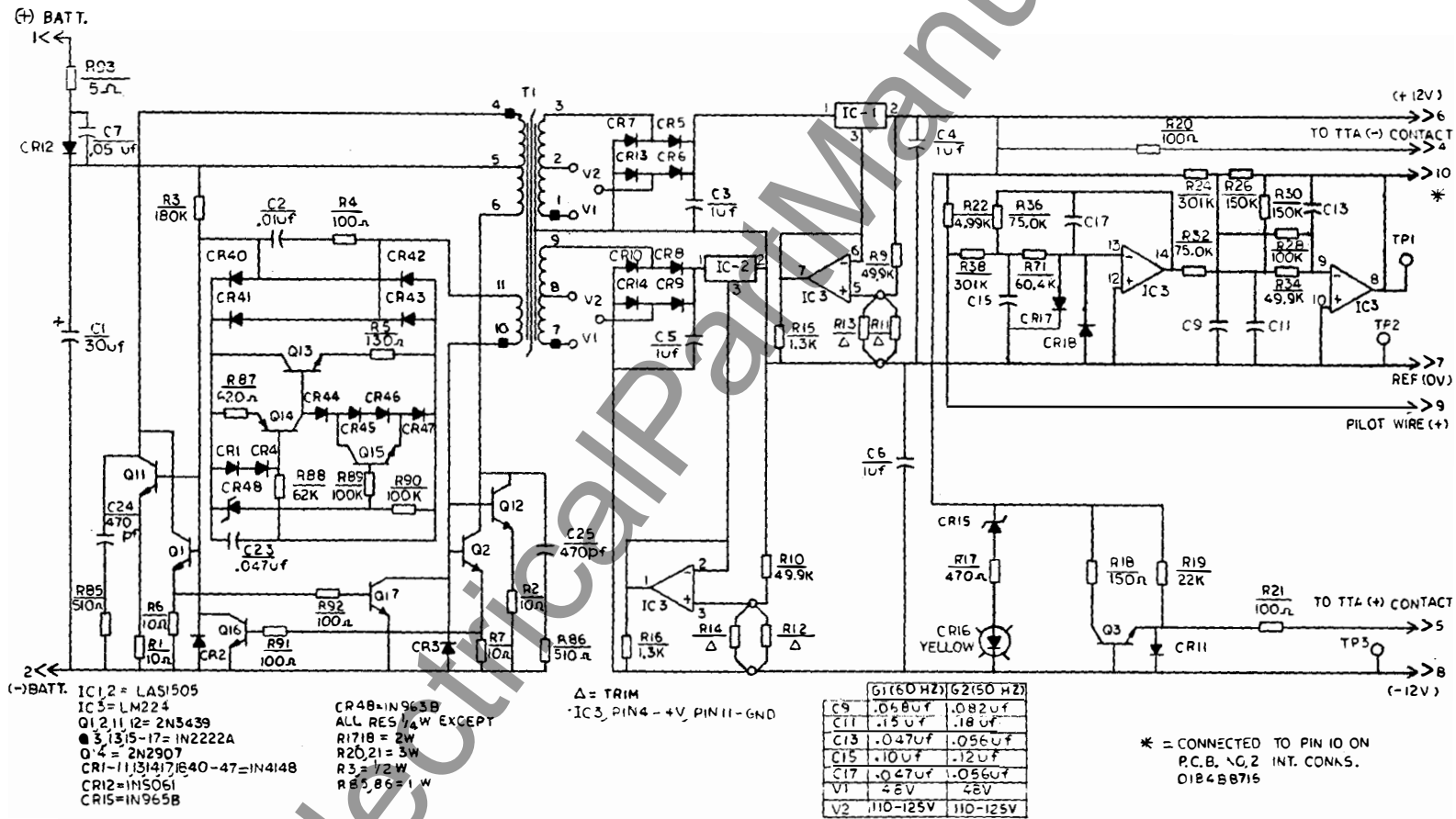
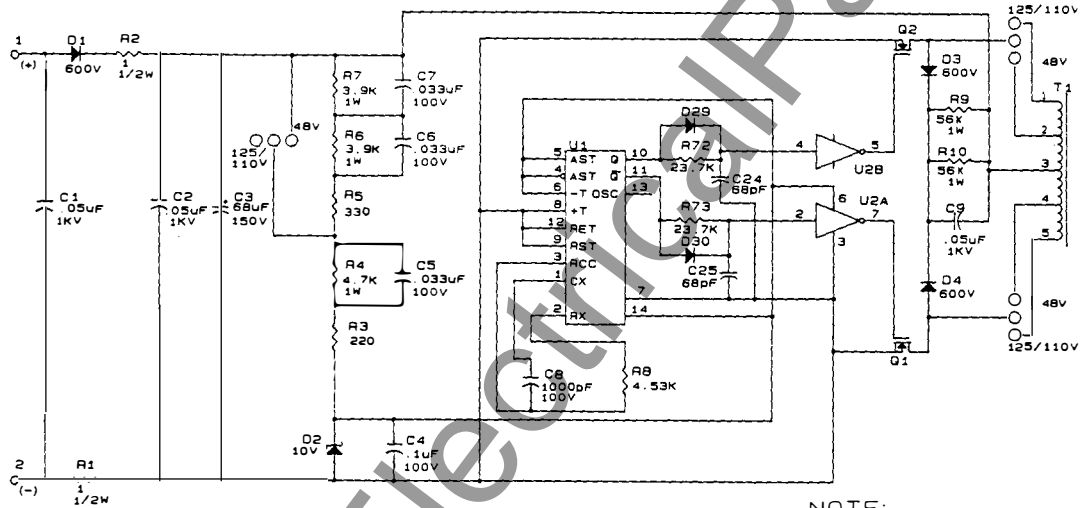
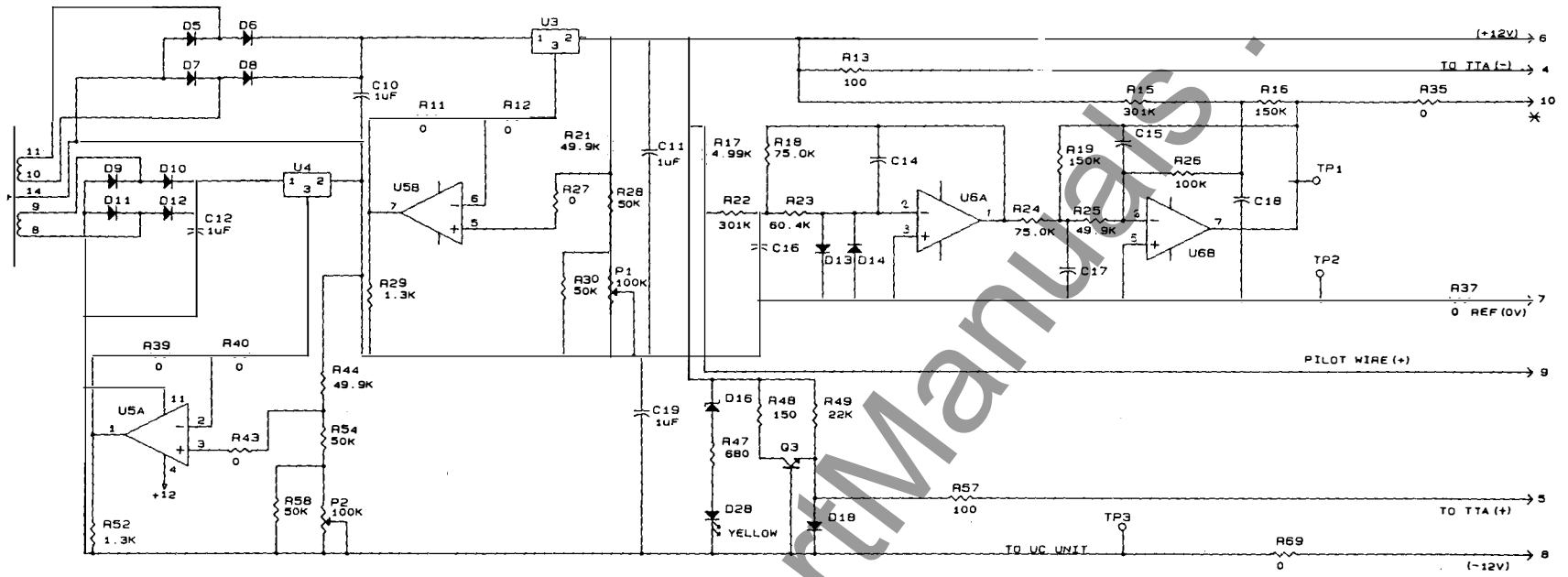

Figure 7a (0184B8712-7) Internal Connections for Printed Circuit Board in Position PCB-1 in SPA11B (No rev. letter) Board Identity: 0184B8612-G-

Figure 7b (0153D7689) Internal Connections for Printed Circuit Board  
 in Position PCB-1 in SPA11B (Rev.A) Board Identity: 0184B8730 G-



	G3	G4
C14	.047uF	.056uF
C15	.047uF	.056uF
C16	.10uF	.12uF
C17	.15uF	.18uF
C18	.068uF	.082uF

NOTE:

1. UNLESS OTHERWISE SPECIFIED ALL RESISTORS ARE IN OHMS AND ARE 1/4 W.
2. \* CONNECTED TO PIN 10 ON PCB NO 2 INTERNAL CONNECTIONS 0184B8716

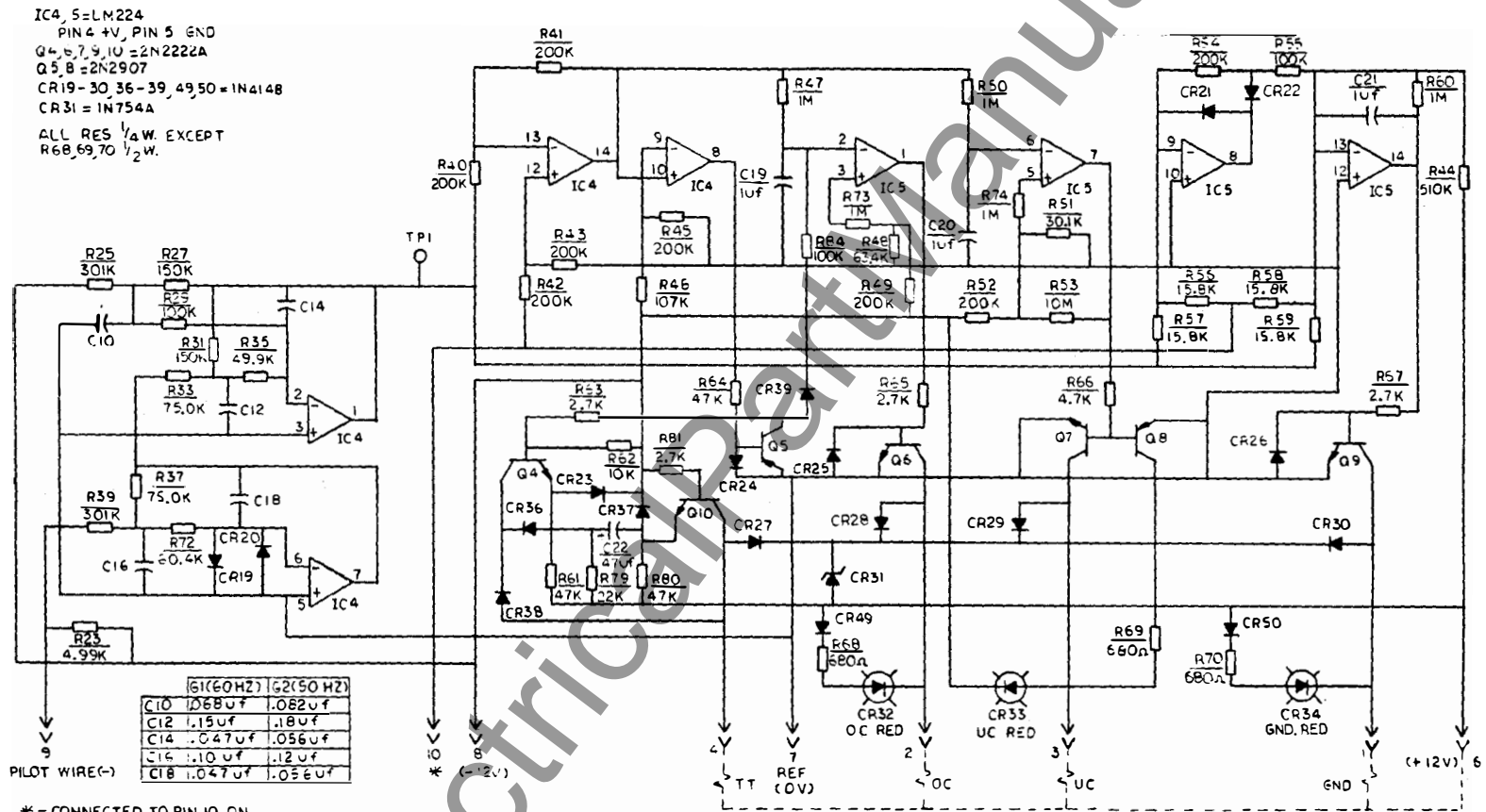

IC4, 5=LM224  
 PIN 4 +V, PIN 5 GND  
 Q4, 5, 7, 9, 10 = 2N2222A  
 Q5, 8 = 2N2907  
 CR19-30, 36-39, 49, 50 = 1N4148  
 CR31 = 1N754A  
 ALL RES 1/4W. EXCEPT  
 R68, 69, 70 1/2W.

	G1(60HZ)	G2(50HZ)
C10	106 <u>u</u> f	1.062 <u>u</u> f
C12	1.15 <u>u</u> f	.18 <u>u</u> f
C14	.047 <u>u</u> f	.056 <u>u</u> f
C16	.10 <u>u</u> f	.12 <u>u</u> f
C18	1.047 <u>u</u> f	1.056 <u>u</u> f

\* = CONNECTED TO PIN 10 ON  
 P.C.B. NO.1 INT. CONNS.  
 0184B8712

Figure 8 (0184B8716-1) Internal Connections for Printed Circuit Board  
 in Position PCB-2 in SPA11B (both no rev. letter and Rev.A) Board Identity: 0184B8616 G-

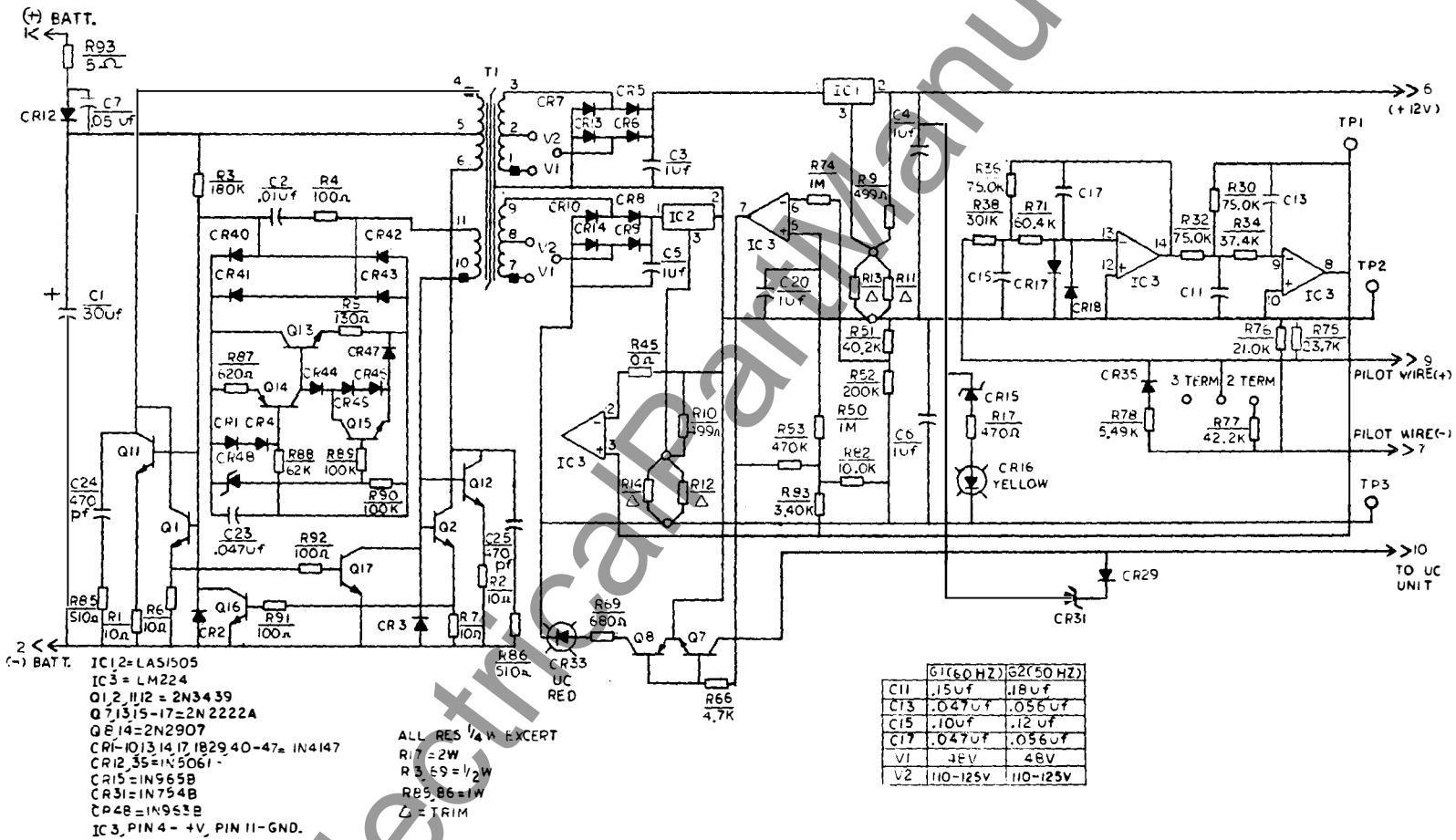
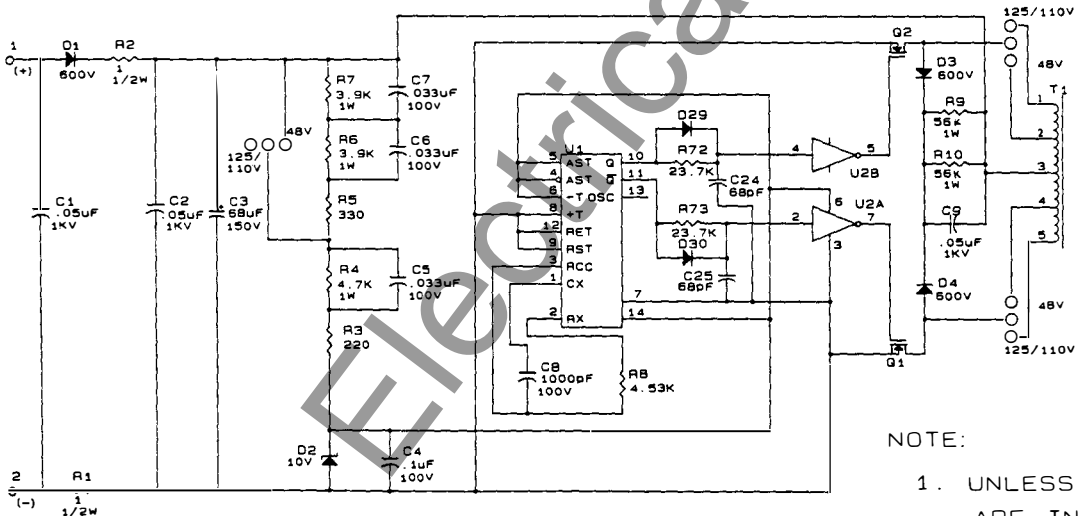
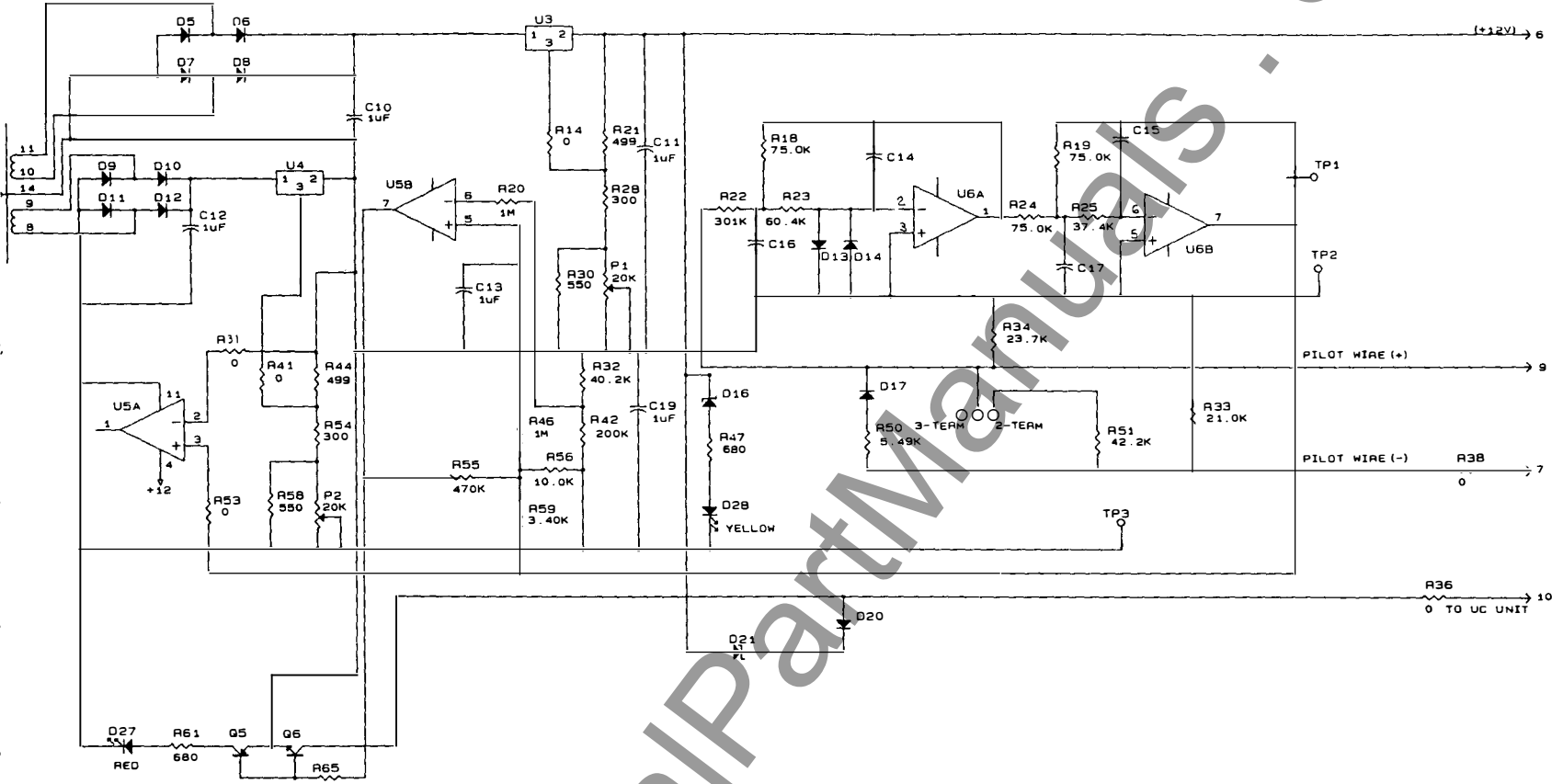

Figure 9a (0184B8715-4) Internal Connections for Printed Circuit Board in Position PCB-1 in SPA12A (No rev. letter) Board Identity: 0184B8615 G-

Figure 9b (0153D7690) Internal Connections for Printed Circuit Board in Position PCB-1 in SPA12A (Rev.A) Board Identity: 0184B8730 G-



	G5	G6
C14	.047uF	.056uF
C15	.047uF	.056uF
C16	.10uF	.12uF
C17	.15uF	.18uF

NOTE:  
1. UNLESS OTHERWISE SPECIFIED ALL RESISTORS ARE IN OHMS AND ARE 1/4 W.

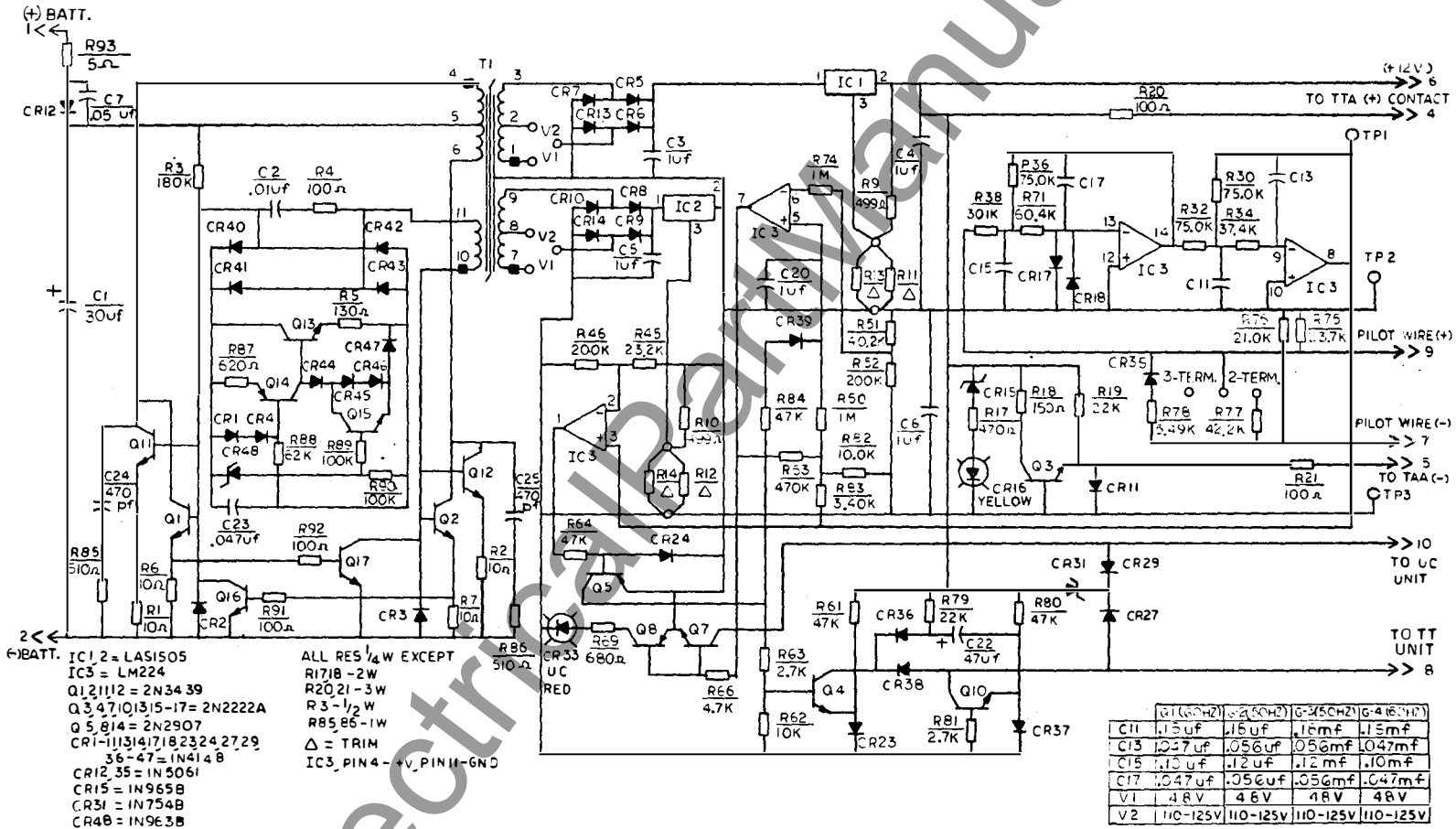
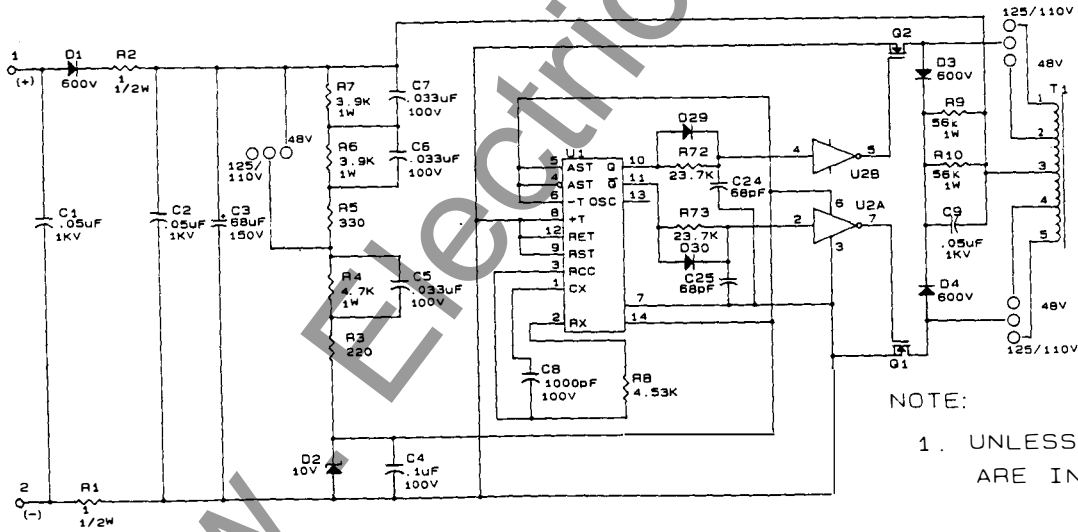
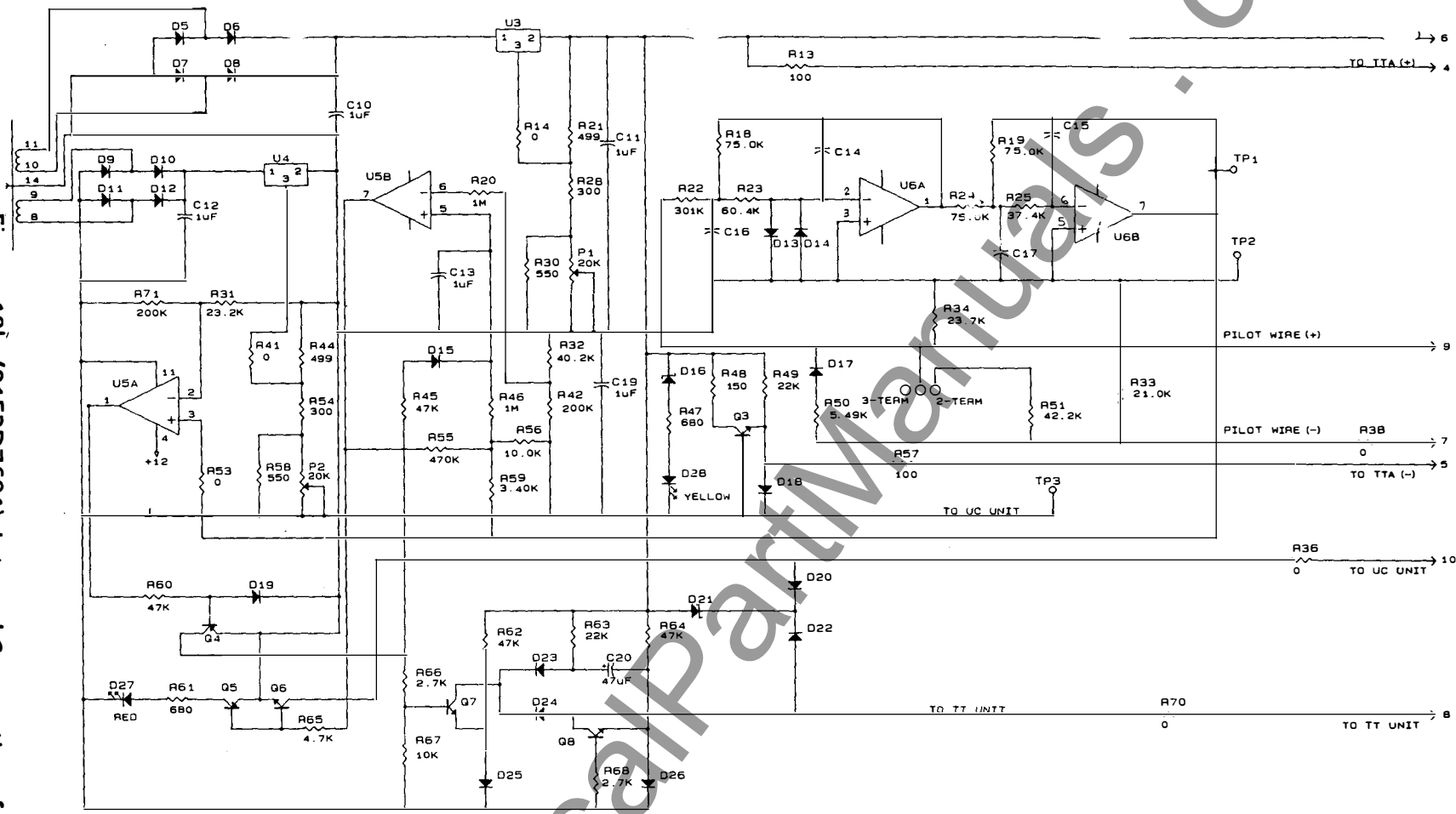

Figure 10a (0184B8713-6) Internal Connections for Printed Circuit Board in Position PCB-1 in SPA12B (No rev. letter) Board Identity: 0184B8613 G-

Figure 10b (0153D7691) Internal Connections for Printed Circuit Board in Position PCB-1 in SPA12B (Rev.A) Board Identity:0185B8730 G-)



	G7	G8
C14	.047uF	.056uF
C15	.047uF	.056uF
C16	.10uF	.12uF
C17	.15uF	.18uF

NOTE:

1. UNLESS OTHERWISE SPECIFIED ALL RESISTORS ARE IN OHMS AND ARE 1/4 W

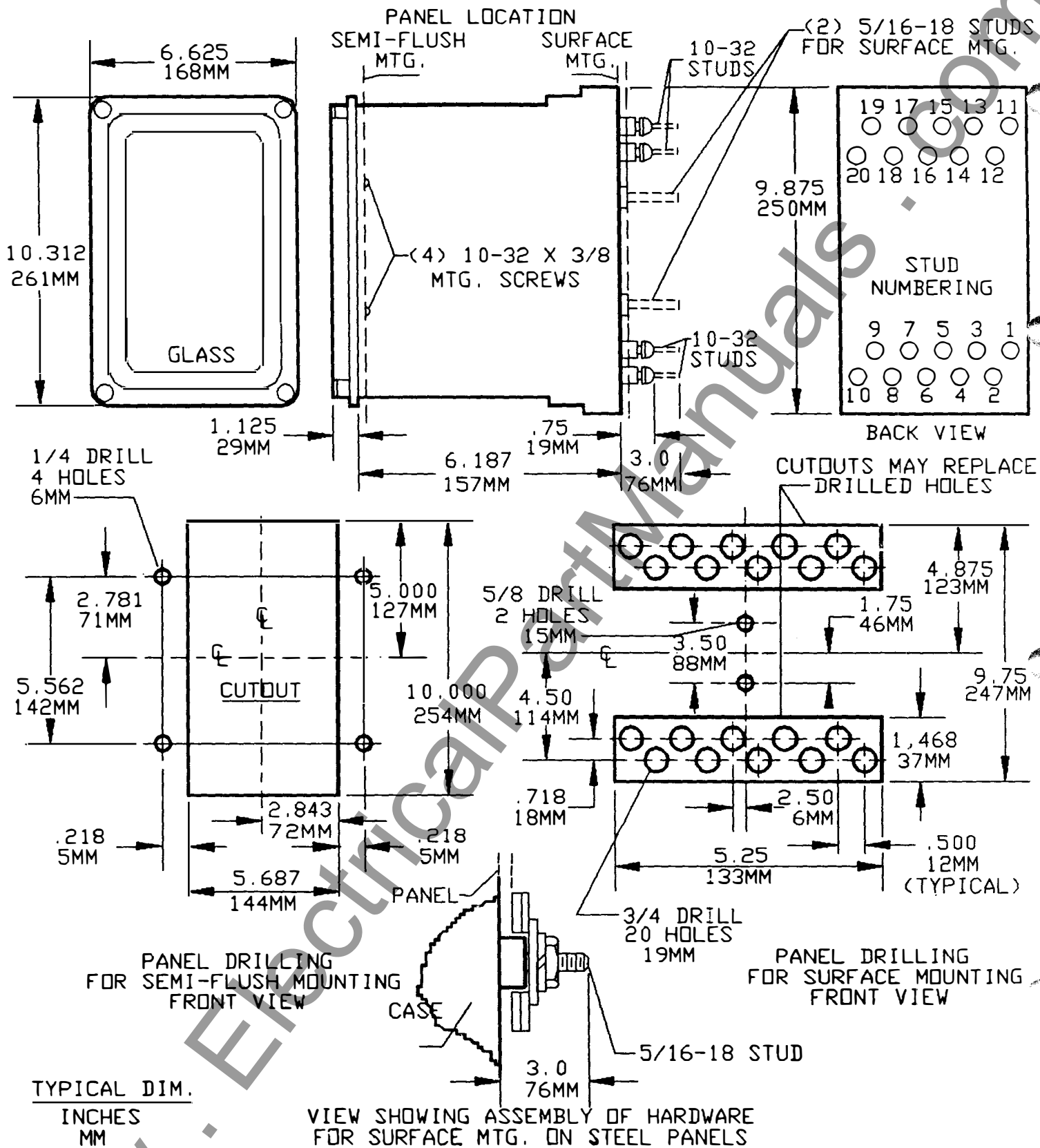

Figure 11 (006209272 [7]) Outline and Panel Drilling

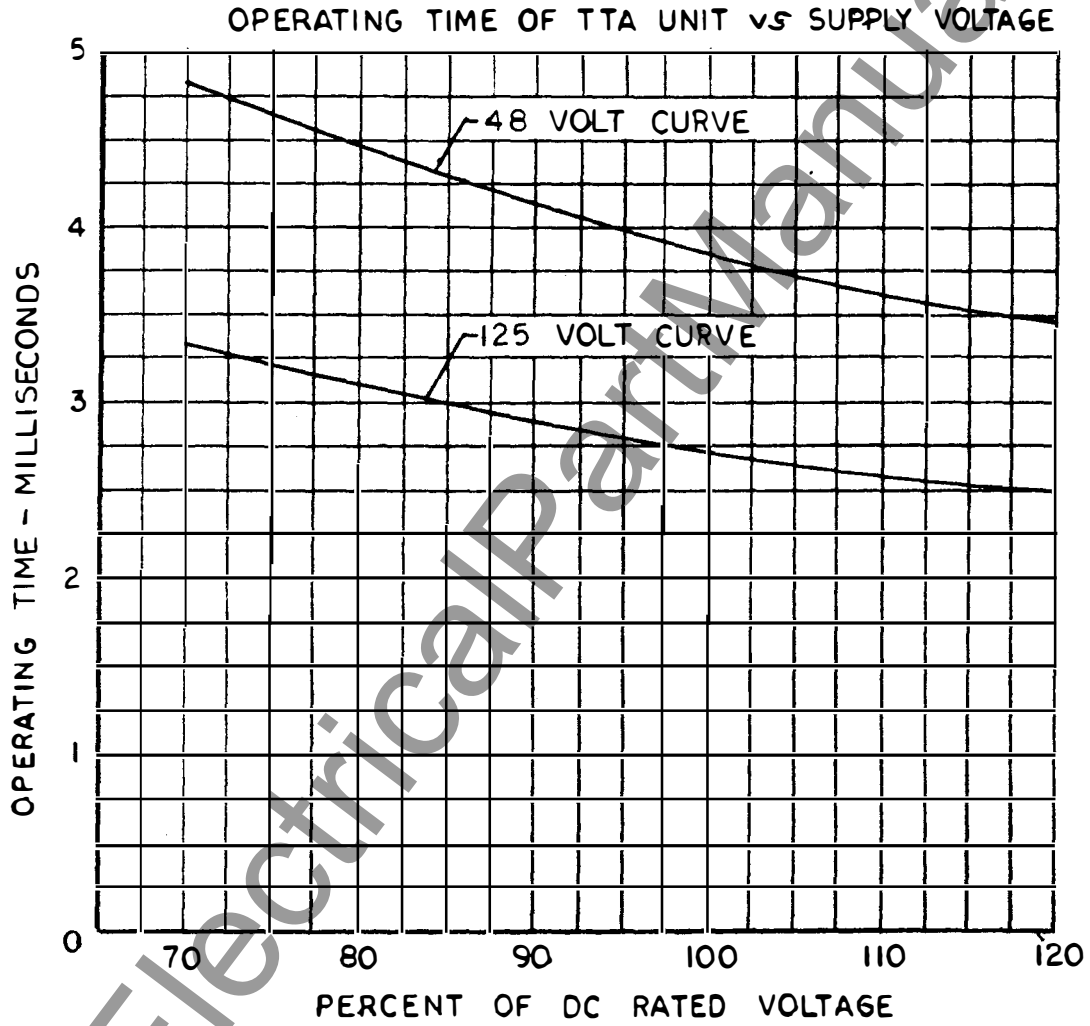

Figure 12 (0275A3814-0) TTA Operating Time Versus Supply Voltage

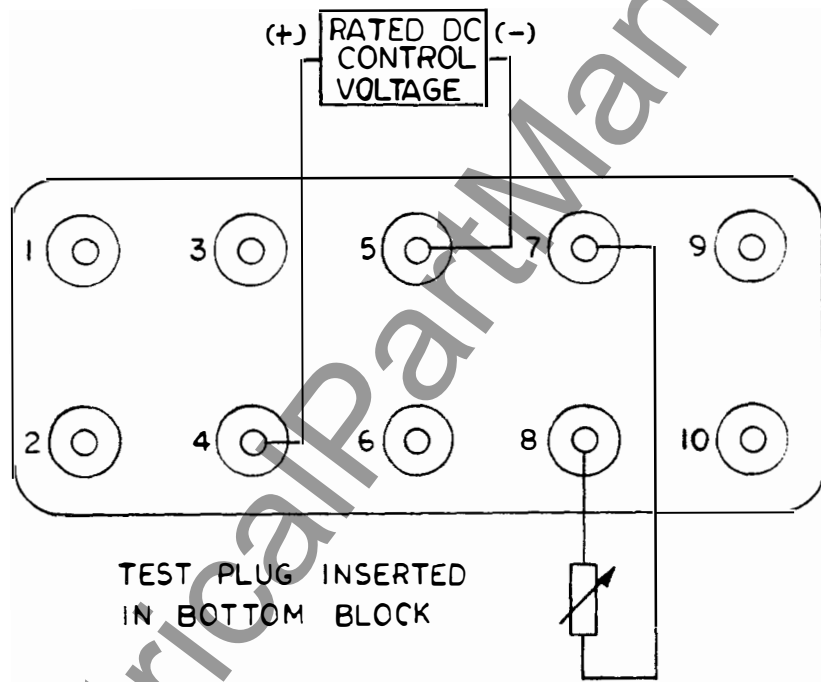

Figure 15 (0275A3815-1) Test Plug Connections for SPA11A and 11B UC and OC Acceptance Test

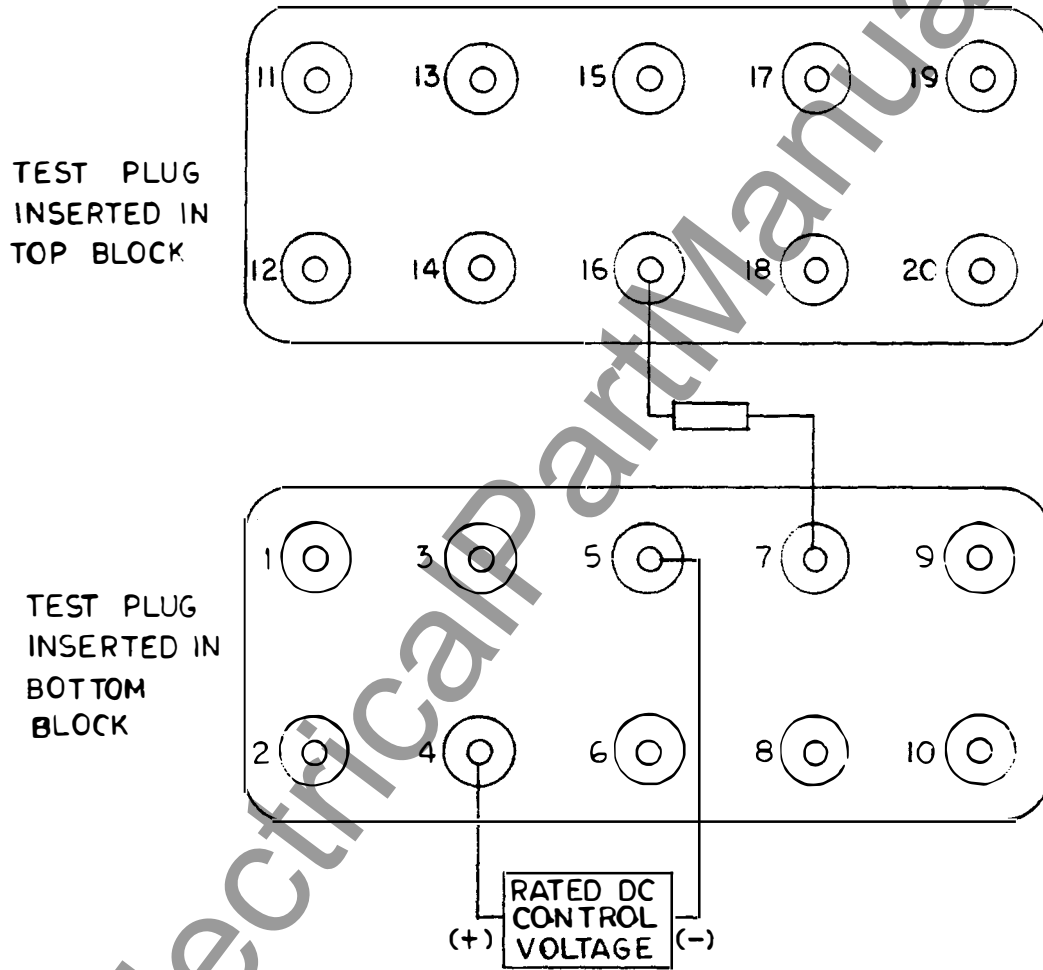

Figure 16 (0275A3816-1) Test Plug Connections for SPA11A and 11B GND Acceptance Test

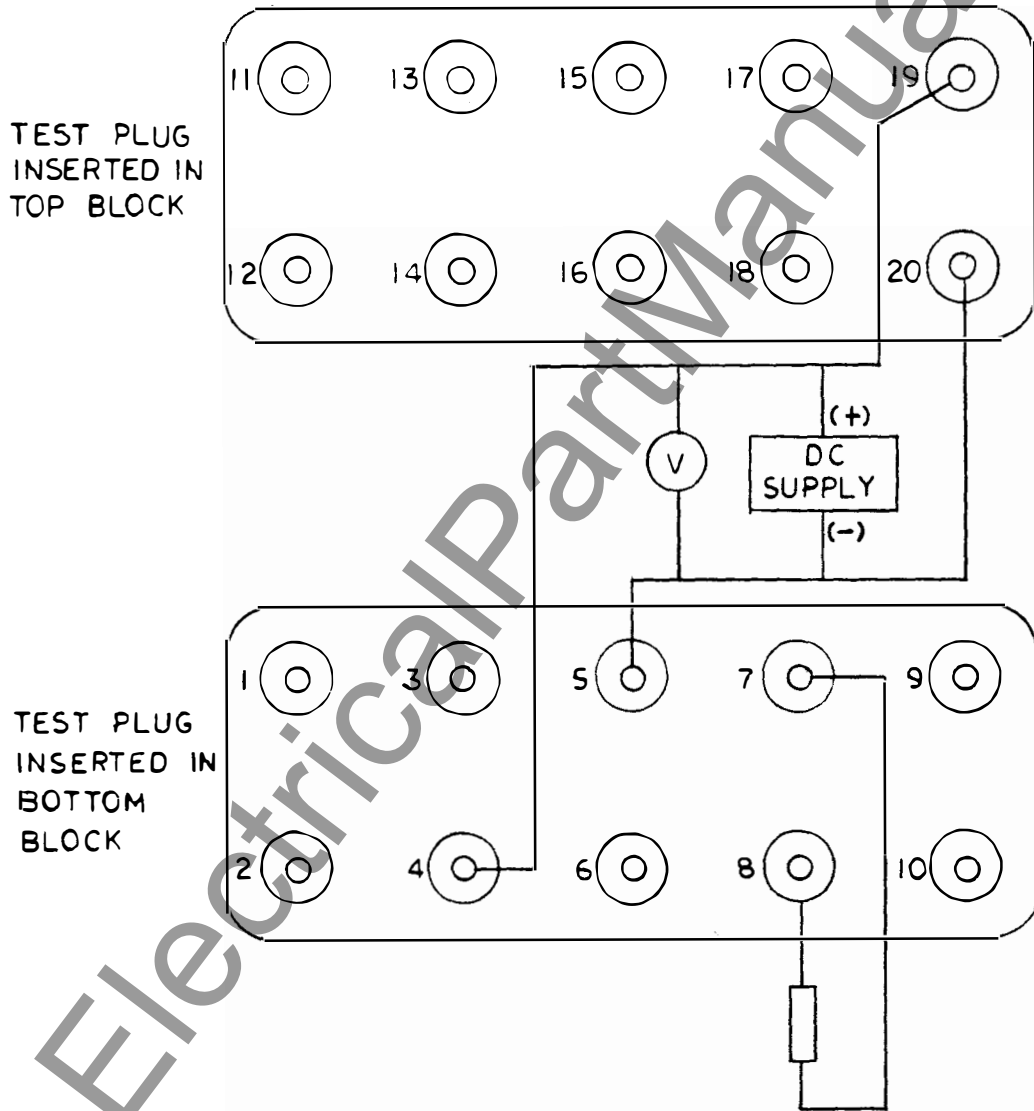

Figure 17 0275A3817-0) Test Plug Connections for SPA11B Transfer Trip Acceptance Test

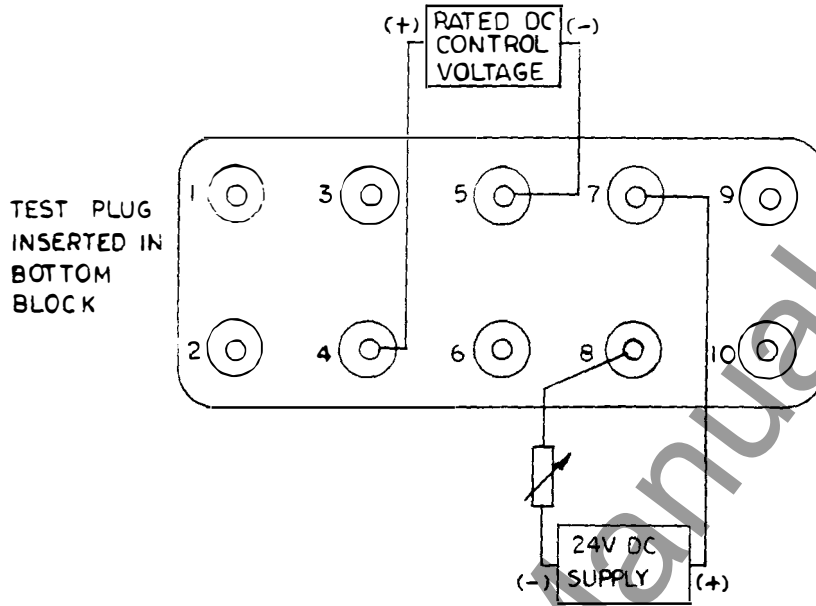

Figure 18 ((0275A3818-1) Test Plug Connections for SPA12A and 12B UC Acceptance Test

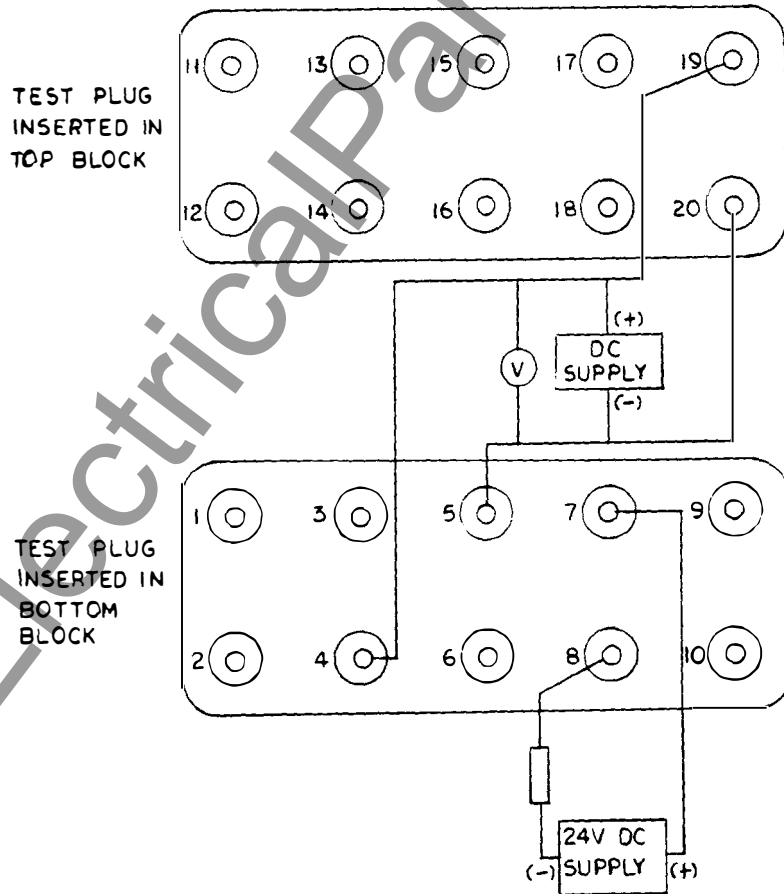
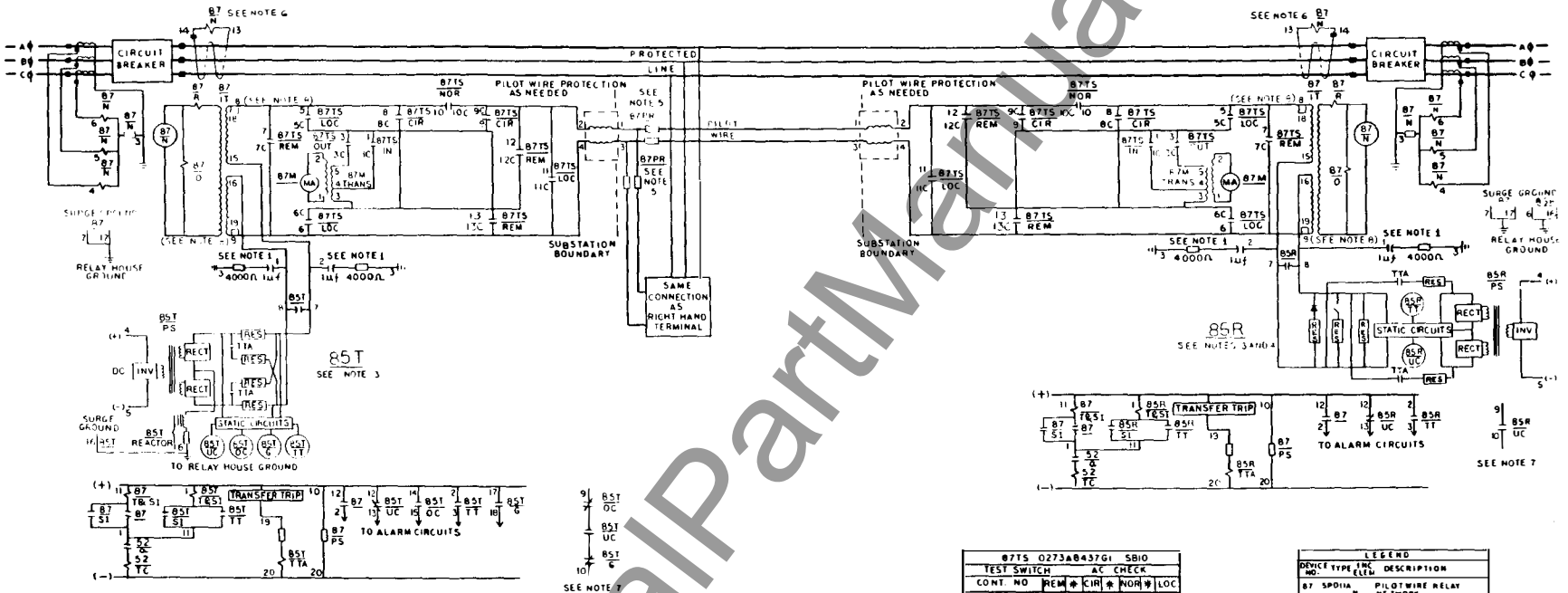

Figure 19 (0275A3819-0) Test Plug Connections for SPA12B Transfer Trip Acceptance Test





- NOTE 1** THESE CAPACITORS AND RESISTORS REQUIRED ONLY IF NEUTRALIZING REACTORS ARE USED. THESE RESISTORS AND CAPACITORS ARE SUPPLIED ON EXCITING PLATE SUPPLIED WITH NEUTRALIZING REACTOR 0257A9787 6003
- NOTE 2** CONTACTS 1 AND 2 ARE CLOSED WHEN SWITCH HANDLE IS IN THE IN POSITION. CONTACTS 3 AND 4 ARE OPEN WHEN SWITCH HANDLE IS IN THE IN POSITION. CONTACTS 1 AND 2 OPEN AFTER CONTACTS 3 AND 4 CLOSE WHEN HANDLE IS PULLED OUT. SWITCH SPRING RETURNS TO THE NORMAL POSITION AND TO THE IN POSITION
- NOTE 3** WHEN MONITORING RELAYS ARE NOT USED, CONNECT B7 STUD 15 TO B7 STUD 16
- NOTE 4** OPEN LINK FOR THREE TERMINAL LINES
- NOTE 5** FOR THREE TERMINAL LINES THE PILOT WIRE MUST BE PADDED SO THAT ALL THREE SECTIONS OF PILOT WIRE FROM RELAY TO MIDPOINT HAVE THE SAME SERIES RESISTANCE
- NOTE 6** RESIDUAL GROUND C.T. WHEN USED FOR INCREASED GROUND CURRENT SENSITIVITY
- NOTE 7** LOCKOUT CIRCUIT FOR SPD RELAY WHEN USED TO BE CONNECTED IN SERIES WITH B7 TRIP CIRCUIT
- NOTE 8** CONNECT STUD 9 TO 16 AND 9 TO 19 OF SPD RELAY EXTERNAL TO THE RELAY CASE
- NOTE 9** EACH RELAY CASE SHOULD BE CONNECTED TO THE RELAY HOUSE GROUND WITH A SEPARATE #12 MIN. LARGER COPPER CONDUCTOR OF MINIMUM LENGTH. CONNECT STUD 7 TO 17 OF SPD AND STUD 6 TO 16 OF SPA EXTERNAL TO THE CASE AND TO RELAY HOUSE GROUND WITH MINIMUM LENGTH #12 OR LARGER COPPER CONDUCTOR

B7TS 0273A0437G1 SB10	
TEST SWITCH	AC CHECK
CONT NO	REM * CIR * NOR * LOC
1 TC 2C 2	SEE NOTE 2
3 SC 4C 4	SEE NOTE 2
5 SC 6C 6	
7 TC 8C 8	X X X
9 SC 10C 10	X X X
11 TC 12C 12	X X X
13 TC 13	X

LEGEND	
DEVICE TYPE	DESCRIPTION
B7	SPD11A H PILOT WIRE RELAY NETWORK
O	OPERATE FUNCTION
R	RESTRAINT FUNCTION
I	INSULATING TRANSF
PS	TEST TARGET AND SEAL IN POWER SUPPLY
B7TS	AC CORNS TEST SW
B7M	AC CORNS METER
B7M TRANS	TRANSF FOR METER
B7M SPA11B	MONITOR REL TRANSMIT END
UC	UNDER CURRENT UNIT
C	GROUND DETECTOR UNIT
TTA	TRANSFER TRIP SEND UNIT
TT	TRANSFER TRIP RECEIVE
PS	POWER SUPPLY
B5R SPA12B	MONITOR REL RECEIVE END UNDER CURRENT UNIT
UC	UNDER CURRENT UNIT
TTA	TRANSFER TRIP SEND UNIT
TT	TRANSFER TRIP RECEIVE
PS	POWER SUPPLY
TTA	PADDING RESISTOR (SEE NOTE 5)

DEVICE	INTERNAL CONNECTIONS	OUTLINE
SPD11A	0269A3024	006209274
SPA11B	0275A3241	006109272
SPA12B	0275A3243	006209272
METER	-	0273A9083
TEST SW	0273A4770	0273A9070
METER TRANS	0273A9068	0273A9068

Figure 23 (0138D2459-3) Elementary System Diagram for Pilot Wire Relaying and Two Direction Transfer Trip on Three Terminal Lines Using SPD11A, SPA11B and SPA12B Relays

www.ElectricalPartManuals.com

(12/94) (600)

## ***Protection and Control***

---

GE Technology Center  
Protection and Control  
205 Great Valley Parkway  
Malvern, Pennsylvania 19355-1337