



Instructions

GEK-7366E
Supersedes GEK-7366D

OFFSET MHO BLOCKING RELAY

Type CEB51A

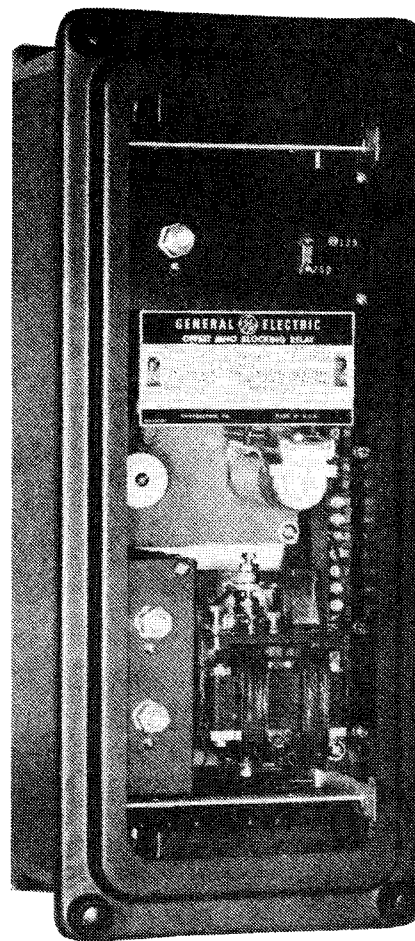

These instructions do not purport to cover all details or variations in equipment nor to provide for every possible contingency to be met in connection with installation, operation or maintenance. Should further information be desired or should particular problems arise which are not covered sufficiently for the purchaser's purposes, the matter should be referred to the General Electric Company.

To the extent required the products described herein meet applicable ANSI, IEEE and NEMA standards; but no such assurance is given with respect to local codes and ordinances because they vary greatly.

CONTENTS

	<u>PAGE</u>
INTRODUCTION.....	3
APPLICATION.....	3
Secondary Current Transformers	3
Mho Offset	4
RATINGS.....	4
Current Circuit	5
Potential Circuit	5
Auxiliary Circuit	5
Contact Circuit	5
CALCULATION OF SETTINGS.....	5
CHARACTERISTICS.....	6
Operating Principles	6
Sensitivity	6
Operating Time	6
Directional Action	6
Transient Overreach	7
BURDENS.....	7
Current Circuit	7
Potential Circuit	7
CONSTRUCTION.....	8
RECEIVING, HANDLING AND STORAGE.....	9
ACCEPTANCETESTS.....	10
Visual Inspection	10
Mechanical Inspection	10
INSTALLATION PROCEDURE	10
Location	10
Mounting	10
Connections	11
ELECTRICAL TESTS	11
OB Unit	11
Diode Polarity	11
MB Unit	11
Clutch Adjustment.....	12
PERIODIC CHECKS AND ROUTINE MAINTENANCE.....	12
Contact Cleaning	12
SERVICING.....	13
Control-Spring Adjustments	13
Directional Check	13
RENEWAL PARTS.....	13
LIST OF FIGURES	14

**OFFSET MHO BLOCKING RELAY
TYPE CEB51A**

INTRODUCTION

The CEB51A relay is a single-phase offset-mho blocking relay operating on the induction-cylinder principle. The induction-cylinder principle provides a high steady torque and a low-burden unit. In addition to the mho unit, the relay also contains a DC-operated auxiliary unit designated OB, which is a slugged-coil telephone-type relay to provide time delay.

The two units, complete with their resistors, capacitors etc., are mounted in the medium, double-ended (M2) case.

- * One relay per terminal is required to provide out-of-step blocking in conjunction with other mho units, such as the M2 unit of a type-GCY relay when the OM3 unit of the GCY is reversed. The auxiliary telephone relay (OB) has its contacts arranged to provide for out-of-step blocking of either reclosing or tripping. The time delay of the OB unit provides the discrimination between out-of-step conditions and fault conditions.

The mho unit is supplied with line-to-line voltage and the vector difference of the currents in these same two lines (delta current). Consequently, the ohmic reach of a unit is the same for three-phase, phase-to-phase, or two-phase-to-ground faults. The ohmic reach is adjusted by means of a tapped transformer in the restraint circuit. A typical external-connection diagram is shown in Figure 10.

APPLICATION

- * These relays are designed to provide out-of-step blocking in conjunction with other mho units, such as the M2 unit of a Type-GCY relay, when the OM3 unit of the GCY relay is connected with reversed connections. An auxiliary telephone-type relay is included, with contacts suitably arranged for out-of-step blocking of either tripping or reclosing. This element has a time-delay pickup so that it will not set up blocking during fault conditions when both the M2 unit of the GCY and the mho blocking unit of the CEB operate almost simultaneously.

The mho unit is supplied with line-to-line voltage and the vector difference of the currents in these same two lines (delta current). Consequently, the ohmic reach of a unit is the same for three-phase, phase-to-phase, or two-phase-to-ground faults. The ohmic reach is adjusted by means of a tapped transformer in the restraint circuit.

Secondary Current Transformers

When the application requires a relay to be set for less than the minimum ohmic reach of the Type-CEB51A relay, two secondary current transformers (CTs) are required to step down the current by a suitable factor. For instance, a 3 ohm setting of the relay can be made the equivalent of a 1.5 ohm relay by the use of two 5/2.5 ampere CTs, one for each of the two currents. It should be remembered in this case that the relay is energized by one-half (1/2) the secondary current of the line CTs, and this fact should be used when referring to operating time or accuracy data recorded as a function of current. Data recorded as a function of relay terminal voltage is not affected.

*Revised since last issue

The use of the secondary step-down CTs reduces the minimum ohmic reach and the offset of these units by the same factor. The remainder of these instructions covers the operation of the relay itself, with no reference to the use of auxiliary current transformers.

Mho Offset

The offset mho unit is similar to the basic mho unit with the addition of a transactor. By adding the transactor secondary voltage in series with the terminal voltage, and applying the vector sum to the operating unit, the effect is to offset the ohmic characteristic without changing its diameter.

The offset is in the direction to include the origin. This enables the offset characteristic to be adjusted to be approximately concentric with the GCY-M2-unit characteristic for use in recognizing out-of-step conditions when used in distance relaying, or in a carrier current scheme in which the OM3 unit of the GCY is connected with reversed connections. Taps are provided on the transactor secondary winding in order to obtain 0, 1, 2, 3, or 4 ohms offset.

- * Representative curves are shown in Figure 2. Curve 3 at 75° shows how the basic minimum reach of a relay, set originally with a 60° angle of maximum torque, increases with an increase in maximum-torque angle to 75°. This is approximately 3.5 at 75° for a 3 ohm relay at 60°. These curves are shown for 100% restraint tap setting. When zero offset is used, these curves all pass through the origin. The angle of offset is also adjustable over the range of 60° to 75°.

RATINGS

- * The relays are available with ratings of 120 volts, 5 amps, 50 or 60 hertz, 60° or 75° angle of maximum torque, and are designed to operate continuously in an ambient temperature not to exceed 55°C.

The angle of maximum torque is continuously adjustable over the range of 60° to 75°. When a relay designed with a 60° angle of maximum torque has the angle of maximum torque increased to 75°, the reach will be approximately 115-125% of the reach at 60°. When a model designed with a 75° angle of maximum torque has the angle of maximum torque decreased to 60°, the reach will be approximately 80-90% of the reach at 75°.

- * The ohmic reach of the relay is 3-30 ohms phase-to-neutral at the factory-set angle of maximum torque (60° or 75° depending on the model selected). The adjustment of reach is made in 5% steps by means of the auto transformer taps. (See lower right portion of Figure 1).

The offset is 0-4 ohms in one-ohm (1) steps measured at 240° lag. The offset will be tap value \pm 15%. The offset taps are located on the tap block on the upper right-hand side of the relay (See Figure 1).

The DC control circuit is dual-rated 125 or 250 VDC, and may be changed from one rating to the other by means of a link on the front of the relay (See Figure 1).

*Revised since last issue

Current Circuit

The current circuit will withstand 5 amperes continuously. The one second (1 sec.) rating is 260 amperes. Higher currents may be applied for shorter periods of time, in accordance with the following equation:

$$I^2t = 67,600$$

where I = current in amperes
t = time less than 1 second

Potential Circuit

The potential circuit will withstand 120 volts continuously.

Auxiliary Circuit

The auxiliary circuit will withstand rated DC voltages (125 or 250 VDC) continuously.

Contact Circuit

The OB unit contacts have the ratings shown in Table I.

TABLE I
CONTACT-INTERRUPTING ABILITY

Volts	Interrupting Capacity (Amps), Inductive ⁺
48 DC	1.0
125 DC	0.5
250 DC	0.25
115 - 60 Cycles	0.75
230 - 60 Cycles	0.5

+ Inductance of average trip coil. The non-inductive interrupting ratings for repetitive protective duty are approximately 2-1/2 times the ratings shown in the table. The contacts will make and carry 30 amperes for tripping duty.

CALCULATION OF SETTINGS

The relay setting is based on the setting of the mho unit with which it is to coordinate to set up the out-of-step blocking. Its setting of reach and offset should be selected so that it is larger and approximately concentric. The maximum torque angles of the two units should be made equal.

The restraint tap setting to be used may then be calculated from the following:

$$T = \frac{Z_{min}}{Z_f + Z_o} \times 100$$

where: Z min = basic minimum ohmic reach of MB unit, 3 ohms at 60°
3.5 ohms at 75°

* (for a relay calibrated at the factory for 3 ohms at 60°)

Z_f = ohmic reach in the forward, or tripping, direction
 Z_o = ohmic reach in the offset, or reverse, direction
 T = percent tap setting.

CHARACTERISTICS

Operating Principles

The mho unit of the CEB51 relay is of the four-pole induction-cylinder construction, in which torque is produced by the interaction between a polarizing flux and the fluxes proportional to the restraining and/or operating quantities.

The torque at the balance point of the unit can be expressed by the following equation:

$$\text{Torque} = 0 = EI \cos (\phi - \theta) - KE^2$$

where: E = phase-to-phase voltage
 I = Delta current (I₁ - I₂)
 φ = angle of maximum torque of the unit
 θ = power factor angle of fault impedance
 K - design constant

To prove that the equation defines a mho characteristic, divide both sides by E² and transpose. The equation reduces to:

$$\frac{1}{Z} \cos (\phi - \theta) = K$$

or

$$Y \cos (\phi - \theta) = K$$

Thus, the unit will pick up at a constant component of admittance at a fixed angle, depending on the angle of maximum torque. Hence the name "mho unit".

When offset is used, the transactor is energized with line current and introduces a voltage (proportional to the current) added to the line-to-line voltage received by the unit. This voltage offsets the circular characteristic of the MB unit in the R-X diagram.

Sensitivity

The sensitivity of the MB unit without offset is shown in Figure 3. Figure 4 shows the effect of offset.

Operating Time

- * The OB unit will open its normally-closed contact in 55-77 milliseconds when rated voltage is suddenly applied to the unit. The pickup voltage is 75% or less of rated voltage.

*

Directional Action

- * The MB unit has been carefully adjusted to have correct directional action under steady-state, low-voltage, and low-current conditions. For faults in the non-tripping direction (zero offset) the unit will not close its contacts through the range of 0-30 amperes. For faults in the tripping direction, the unit will close its contacts with as little as 2% voltage applied over the range of 6-60 amperes.

*Revised since last issue

Transient Overreach

* Since the MB unit operates a time-delay unit (OB), the transient overreach is of little significance and is therefore not as controlled as would be a zone 1 (M1) unit.

BURDENS

Current Circuit

The burden of the current circuit is little affected by the offset tap used, and the value imposed on each current transformer is as shown in Table II.

TABLE II

Amps	Frequency (Hz)	R	+jx	Power Factor	Watts	Volt Amps
5	60	.14	.14	.7	3.5	5

Potential Circuit

The potential burdens imposed on each potential transformer (PT), at 120 volts with the restraint taps at 100% and the offset at zero (0), is as shown in Table III.

TABLE III

Circuit	R	X	Power Factor	Watts	VARs	Volt Amps
Polarizing	1400	-j50	.99	10.3	---	10.3
Restraint	740	+j1750	.39	3.0	7.0	7.7

When offset is used, the potential circuit may be represented as:

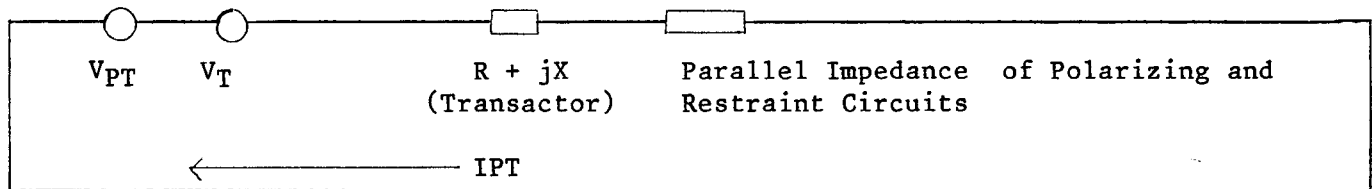

where VT is the output voltage of the transactor and VPT is the input voltage to the relay potential circuit.

Thus, the burden on the PT would be:

$$V_{PT} \times I_{PT}$$

and

$$I_{PT} = \frac{V_{PT} + V_T}{Z_s} \quad (\text{Positive if load or fault current is opposite of Offset})$$

where:

- I_{PT} = current in Potential Circuit
- V_{PT} = input voltage to relay
- V_T = output voltage of transactor
- Z_s = impedance of Potential Circuit

and

$$V_T = \sqrt{3} I_L \times Z_T / \theta - 75$$

where:

- I_L = load current
- Z_T = ohmic offset
- θ = Power Factor angle of I_L

and

$$Z_s = \frac{Z_p \times Z_r \left(\frac{100}{T}\right)^2}{Z_p + Z_r \left(\frac{100}{T}\right)^2} + Z_T^2 (4.5 + j14.5)$$

$$Z_s = (a + jb) + (c + jd)$$

To aid in the calculation of burden, the following values have been calculated:

<u>Restraint Tap (T)</u>	<u>a + jb</u>		<u>Z_T</u>	<u>c + jd</u>	
100	845	452	0	0	
50	1260	160	1	4.5	14.5
25	1370	0	2	18	58
			3	41	131
			4	72	232

Thus, for 0.86 power factor load of 5 amperes into the protected line, the potential burden has been calculated for the following conditions:

<u>Restraint Tap (T)</u>	<u>Offset Ohms</u>	<u>Watts</u>	<u>VARs</u>
100	0	13.3	7.0
100	1	13.3	8.2
50	2	11.9	3.3
25	3	11.6	2.7
25	4	11.3	3.9

CONSTRUCTION

The Type-CEB51 relays are assembled in the medium-size double-ended (M2) drawout case, having studs at both ends in the rear for external connections. The electrical connections between the relay and case studs are through stationary molded inner and outer blocks, between which nests a removable connecting plug. The outer blocks have the studs for the external connections, and the inner blocks have the terminals for the internal connections.

Every circuit in the drawout case has an auxiliary brush, as shown in Figure 5, to provide adequate overlap when the connecting plug is withdrawn or inserted. Some circuits are equipped with shorting bars (see internal connections in Figure 6), and on those circuits it is especially important that the auxiliary brush make contact, as indicated in Figure 5, with adequate pressure to prevent the opening of important interlocking circuits.

The relay mechanism is mounted in a steel framework called the cradle, and is a complete unit by all leads terminated at the inner blocks. This cradle is held firmly in the case by a latch at both top and bottom and by a guide pin at the back of the case. The connecting plug, besides making the electrical connections

between the respective blocks of the cradle and case, also locks the latch in place. The cover, which is drawn to the case by thumbscrews, holds the connecting plugs in place. The target reset mechanism is a part of the cover assembly.

The relay case is suitable for either semiflush or surface mounting on all panels up to 2 inches thick, and appropriate hardware is available. However, panel thickness must be indicated on the relay order, to ensure that proper hardware will be included. Outline and panel drilling is shown in Figure 11.

A separate testing plug can be inserted in place of the connecting plug to test the relay in place on the panel, either from its own source of current and voltage, or from other sources. Or the relay can be drawn out and replaced by another that has been tested in the laboratory.

Figure 1 shows the relay removed from its drawout case with all major components identified. Symbols used to identify circuit components are the same as those that appear on the internal-connections diagram in Figure 6.

The relay includes a mho unit designated as MB, and a telephone-type relay designated as OB.

The rheostat for adjusting the angle of maximum torque (R2), the rheostat for making fine adjustment of the reach setting (R1), the rheostat for setting the transactor angle (R4), the autotransformer and offset tap blocks, and the DC control voltage links are all front mounted and can be adjusted from the front of the relay. Thus all adjustments, including any adjustments of the telephone relay, can be made from the front of the relay without removing it from its case.

*

RECEIVING, HANDLING AND STORAGE

These relays, when not included as part of a control panel, will be shipped in cartons designed to protect them against damage. Immediately upon receipt of a relay, examine it for any damage sustained in transit. If injury or damage resulting from rough handling is evident, file a damage claim at once with the transportation company and promptly notify the nearest General Electric Sales Office.

Reasonable care should be exercised in unpacking the relay in order that none of the parts are injured nor the adjustments disturbed.

If the relays are not to be installed immediately, they should be stored in their original cartons in a place that is free from moisture, dust and metallic chips. Foreign matter collected on the outside of the case may find its way inside when the cover is removed, and cause trouble in the operation of the relay.

* Revised since last issue

ACCEPTANCE TESTS

Immediately upon receipt of the relay, an INSPECTION AND ACCEPTANCE TEST should be made to make sure that no damage has been sustained in shipment and that the relay calibrations have not been disturbed. If the examination or test indicates that readjustment is necessary, refer to the section on **SERVICING**.

Visual Inspection

Check the nameplate stamping to make sure that the model number and rating of the relay agree with the requisition.

Remove the relay from its case and check that there are no broken or cracked molded parts or other signs of physical damage, and that all screws are tight.

Mechanical Inspection

1. It is recommended that the mechanical adjustments in Table IV be checked.

TABLE IV

MB Unit Check Points	OB Unit Check Points
Rotating shaft end play 0.010 to 0.015"	Normally-open contact gap 0.015" minimum
Contact gap 0.040 to 0.060"	Wipe on N.O. contacts 0.010" minimum
Contact wipe 0.003 to 0.005"	Residual pin projection 0.005" minimum
Clutch setting ⁺⁺ 40 to 60 grams	Contact pressure 15 grams minimum

⁺⁺ Measured at the moving contact tip; hold the cup securely.

2. There should be no noticeable friction in the rotating structure of the units.
3. Make sure the control spring is not deformed and spring convolutions do not touch each other.
4. With the relay well leveled in its upright position, the contacts of the MB unit must be open. The moving contact should rest against the backstop.
5. The armature contacts of the seal-in unit should move freely when operated by hand. There should be at least 1/32" wipe on the seal-in contacts.
6. Check the location of the contact brushes on the cradle and case blocks against the internal-connections diagram for the relay.

INSTALLATION PROCEDURE

Location

The location of the relay should be clean and dry, free from dust, excessive heat and vibration, and should be well lighted to facilitate inspection and testing.

Mounting

The relay should be mounted on a vertical surface. The outline and panel-drilling dimensions are shown in Figure 11.

Connections

The internal connections of the CEB51A relay are shown in Figure 6. An elementary diagram of typical external connections is shown in Figure 10.

ELECTRICAL TESTS

OB Unit

With the connection shown in Figure 7, and MB contacts blocked closed, the OB unit should pick up between 60% and 80% of the DC control voltage selected by the link position.

- * With V set at rated voltage and MB contacts closed, the operating time to open the normally-closed contact should be between 0.055 and 0.080 seconds.

Diode Polarity

Place the tap link in the 250 VDC position.

Connect positive 250 VDC to stud 1 and negative to stud 2; the current should be approximately zero (0).

Reverse the connections to studs 1 and 2; the current should be 20-40 milliamperes.

MB Unit

Before any electrical tests are made on the MB unit, the relay should be connected as shown in Figure 8 and allowed to **warm up** for approximately 15 minutes with rated voltage applied and the restraint taps set at 100%.

Angle of Maximum Torque

- * With the offset taps set at zero (0) and restraint taps set at 100%, set V for 55 volts and I for 15 amperes. The angle of maximum torque should be as listed below:

	Model	
	12CEB51A1A, 2A, 7A, 8A	12CEB51A3A, 4A, 5A, 6A, 9A
Angle of Maximum Torque	60° ± 1°	75° ± 1°
Phase Angle Meter Reading (if meter reads angle I leading V)	300° ± 1°	285° ± 1°

R2 may be adjusted to change the angle of maximum torque.

*Revised since last issue

* Ohmic Reach (3 ohm minimum relay)

Using the same connection and tap settings as used for "Angle of Maximum Torque", set phase shifter to the maximum torque angle and set $V = 55$ volts; unit should pick up between 8.9 and 9.4 amperes.

R1 may be adjusted to change the ohmic reach.

* Offset Reach

Using the same connections and restraint tap settings as used for "Angle of Maximum Torque", set the offset taps at 4 ohms. Set phase shifter to 180° from the angle of maximum torque. With $V = 55$ volts, the unit should pick up between 5.8 and 7.9 amperes. If the angle of maximum torque is changed and it is desired to have the offset at the same angle, R4 can be adjusted to obtain the new angle. If R4 is adjusted, the reach of the transactor will change in a manner similar to a mho unit change in angle.

* CLUTCH ADJUSTMENT

The OM units include a high-set clutch between the cup and shaft assembly and the moving contact to prevent damage during heavy fault conditions. These clutches have been set at the factory to slip at approximately 40-60 grams applied tangentially at the moving contact. This can best be checked in the field in terms of volt-amperes by the following method.

Use the connections of Figure 8 and set the phase shifter so that the phase angle meter reads the angle of maximum torque for the unit to be checked, at 120 volts and 5 amperes. Disconnect the No.1 restraint tap leads from the tap block and set offset "out". With voltage across the relay studs set at 120V, increase the current until the clutch just slips. This should occur between 34 and 56 amperes.

PERIODIC CHECKS AND ROUTINE MAINTENANCE

In view of the vital role of protective relays in the operation of a power system, it is important that a periodic test program be followed. It is recognized that the interval between periodic checks will vary depending upon environment, type of relay and the user's experience with periodic testing. Until the user has accumulated enough experience to select the test interval best suited to his individual requirements, it is suggested that the points listed under **ACCEPTANCE TESTS** and **ELECTRICAL TESTS** be checked at an interval of from one to two years.

Contact Cleaning

For cleaning fine silver contacts, a flexible burnishing tool should be used. This consists of a flexible strip of metal with an etch-roughened surface, resembling in effect a superfine file. The polishing action is so delicate that no scratches are left, yet it will clean off any corrosion thoroughly and rapidly. The flexibility of the tool ensures the cleaning of the actual points of contact. Do not use knives, files, abrasive paper or cloth of any kind to clean relay contacts. Knives or files may leave scratches that increase arcing and deterioration of the contacts. Abrasive paper or cloth may leave minute particles of insulating abrasive material in the contacts and thus prevent closing.

The burnishing tool described above can be obtained from the factory.

SERVICING

* If it is found during the installation or periodic tests that the mho unit calibrations are out of limits, they should be recalibrated as outlined in the following paragraphs. It is suggested that these adjustments be made in the laboratory. The circuit components listed below, whose settings are normally considered as factory adjustments, are used in recalibrating the units. These parts may be physically located from Figure 1. Their locations in the relay circuit are shown in the internal-connections diagram of Figure 6.

- R1 - Reach-Adjusting Rheostat
- R2 - Angle-of-Maximum-Torque-Adjusting Rheostat
- * R4 - Offset-Angle-Adjusting Rheostat

Control Spring Adjustments

With the contact gap set per Table IV, adjust the control-spring-adjusting ring so that the moving contact just touches the backstop with the relay de-energized and level.

Directional Check

With the relay connected per Figure 8, restraint taps in 100%, and zero (0) offset, allow the relay to **preheat** for approximately 15 minutes at rated voltage.

Set the phase-angle meter at the angle of maximum torque and reduce the voltage to 2 volts. The relay contact must close over the range of 6-60 amperes.

With the potential circuit short-circuited on itself, the contacts must remain open over the range of 0-30 amperes.

Should the MB unit fail to pass either test, the core must be adjusted. The core and coil assembly is shown in Figure 9.

By use of a special wrench (0178A9455 Pt.1) the core may be rotated 360° in either direction without having either to hold nut "F" or to retighten any parts after the final position of the core has been determined.

The final position of the core is that position where the unit passes both the above directional check tests.

RENEWAL PARTS

Sufficient quantities of renewal parts should be kept in stock for the prompt replacement of any that are worn, broken or damaged.

When ordering renewal parts, address the nearest Sales Office of the General Electric Company. Specify the name of the part wanted, quantity required, and complete nameplate data, including the serial number, of the relay. Where possible, give the GE requisition number on which the relay was furnished.

*Revised since last issue

LIST OF FIGURES

Cover Photo (8038706)	CEB51A Relay in its Case
Figure 1 (8038707)	Type CEB51A Relay Out of Case (Front View)
* Figure 2 (0208A3584-1)	Typical Characteristics of the CEB51A Relay
Figure 3 (0208A3908)	Steady-State and Dynamic Accuracy of the MB Unit of the CEB51A Relay
Figure 4 (0208A3909)	Steady-State Accuracy of the MB Unit (with Offset) in the CEB51A Relay
Figure 5 (8025039)	Cross Section of Drawout Case Showing Position of Auxiliary Brush and Shorting Bar
* Figure 6 (0178A9134-3)	Typical Internal Connections Diagram for the CEB51A Relay
Figure 7 (0208A2406)	Test Connections for Checking Pickup of the OB Unit of the CEB51A Relay
Figure 8 (0208A2407)	Test-Connections Diagram for Checking Reach and Angle of Maximum Torque of CEB51A Relay
Figure 9 (0208A3583)	Magnet and Coil Breakdown Illustration for the CEB51A Relay
Figure 10 (0208A2405)	Typical External-Connections Diagram for the CEB51A Relay
* Figure 11 (K6209274-4)	Outline and Panel-Drilling Dimensions for Drawout Relays, Size M2

*Revised since last issue

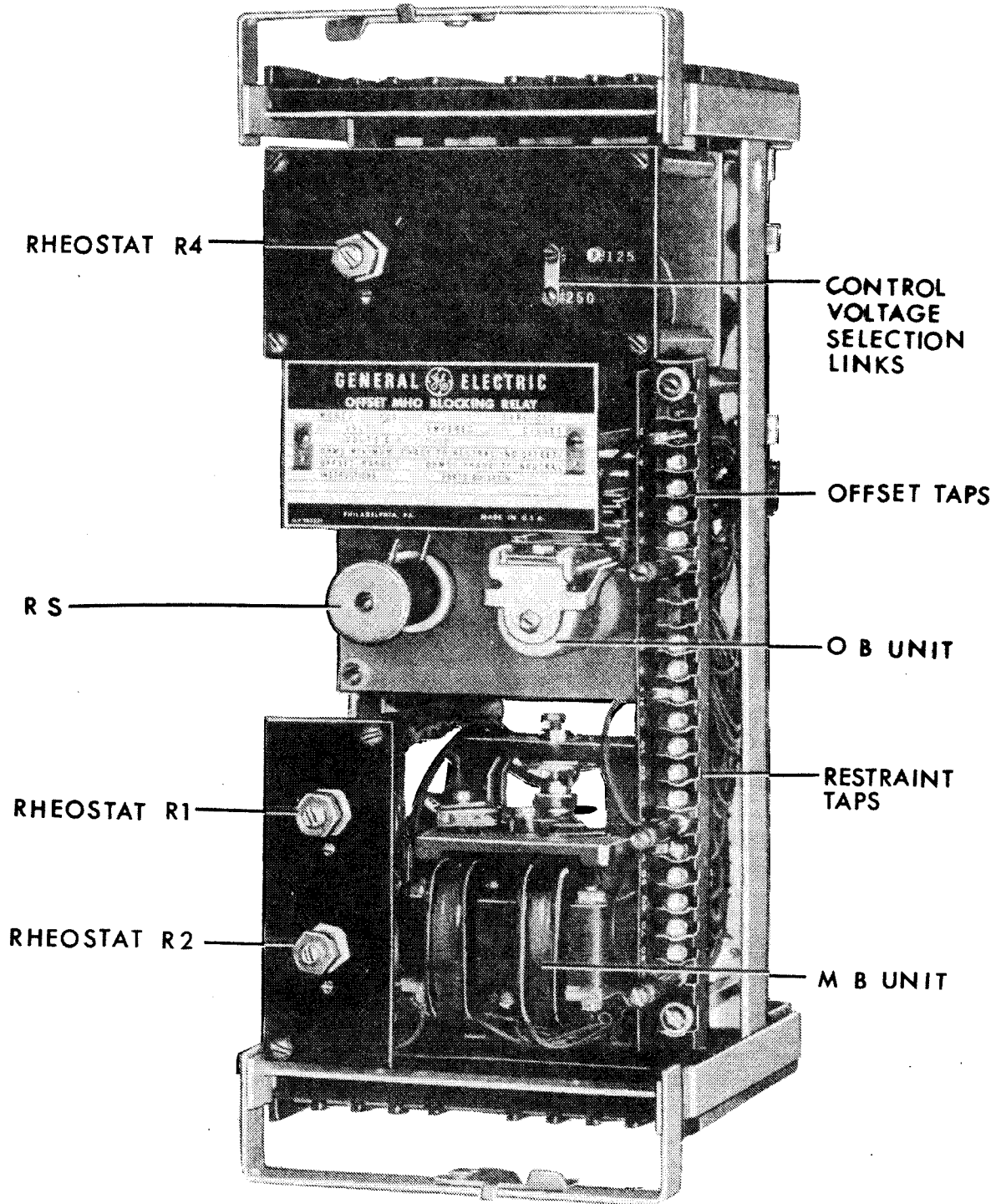
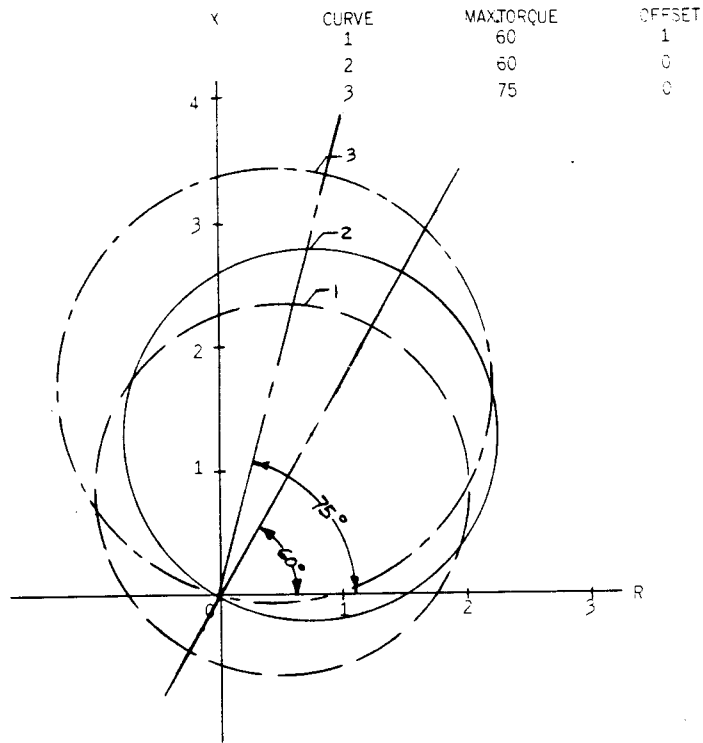

Figure 1 (8038707) Type CEB51A Relay Out of Case (Front View)

GEK-7366



* Figure 2 (0208A3584-1) Typical Characteristics of the CEB51A Relay

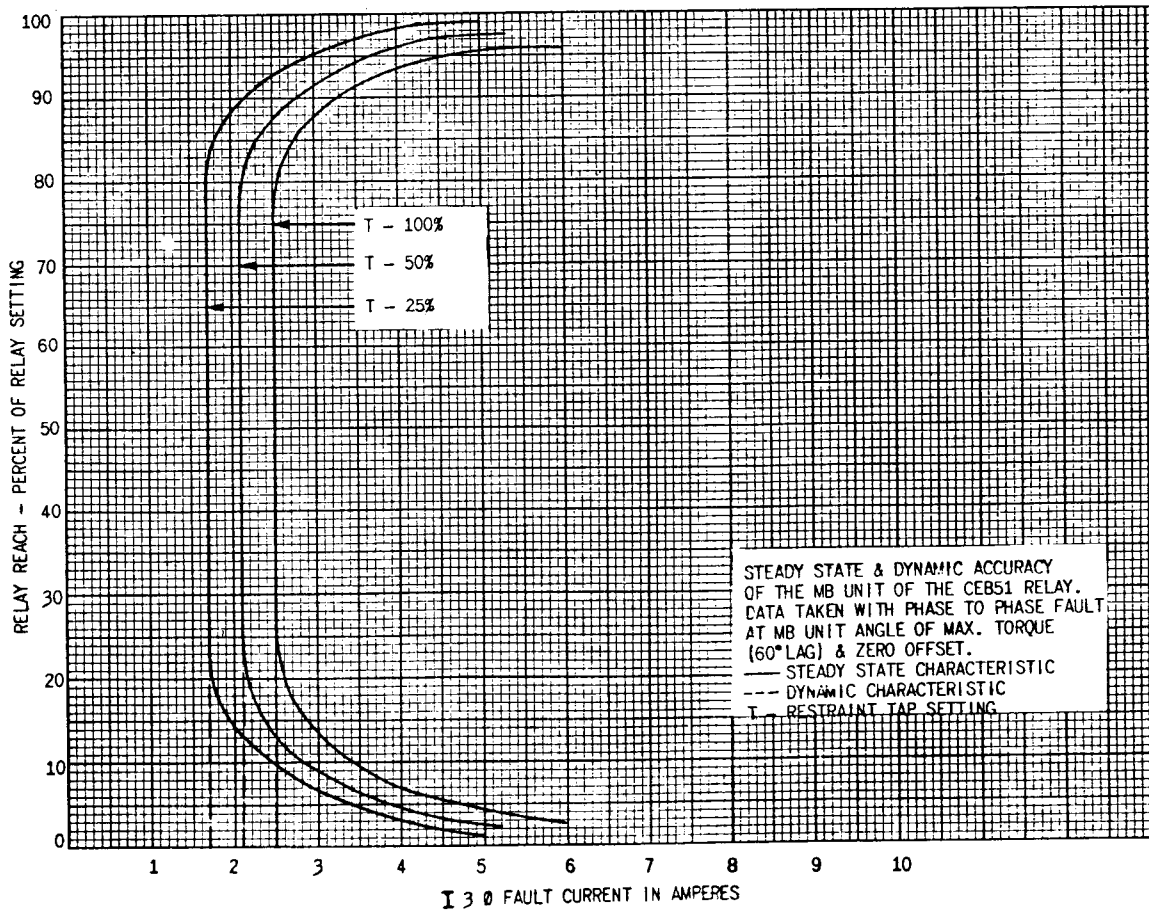

Figure 3 (0208A3908) Steady-State and Dynamic Accuracy of the MB Unit of the CEB51A Relay

*Revised since last issue

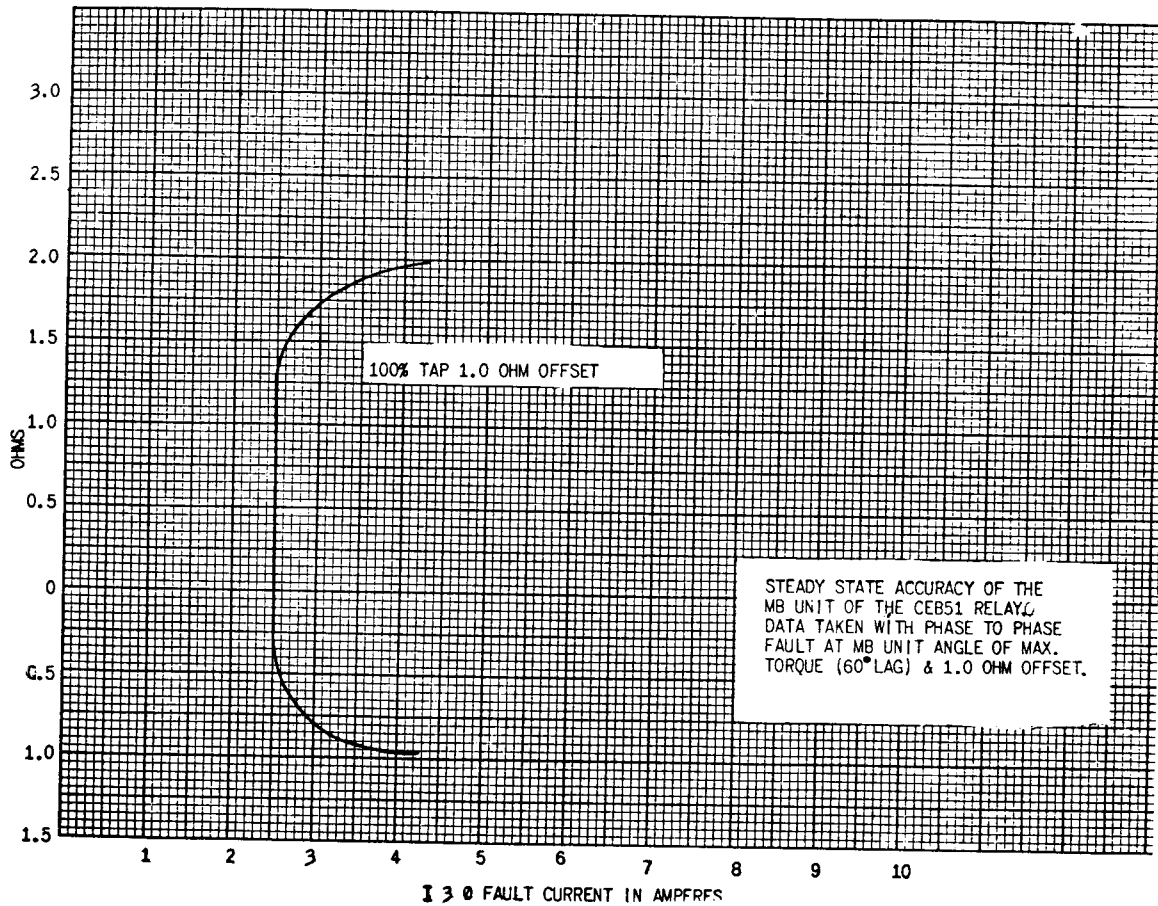
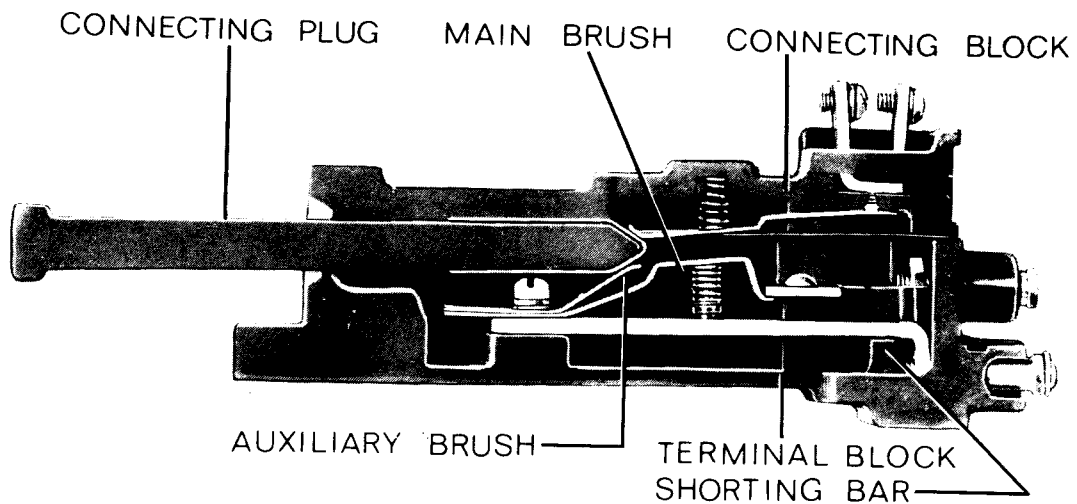
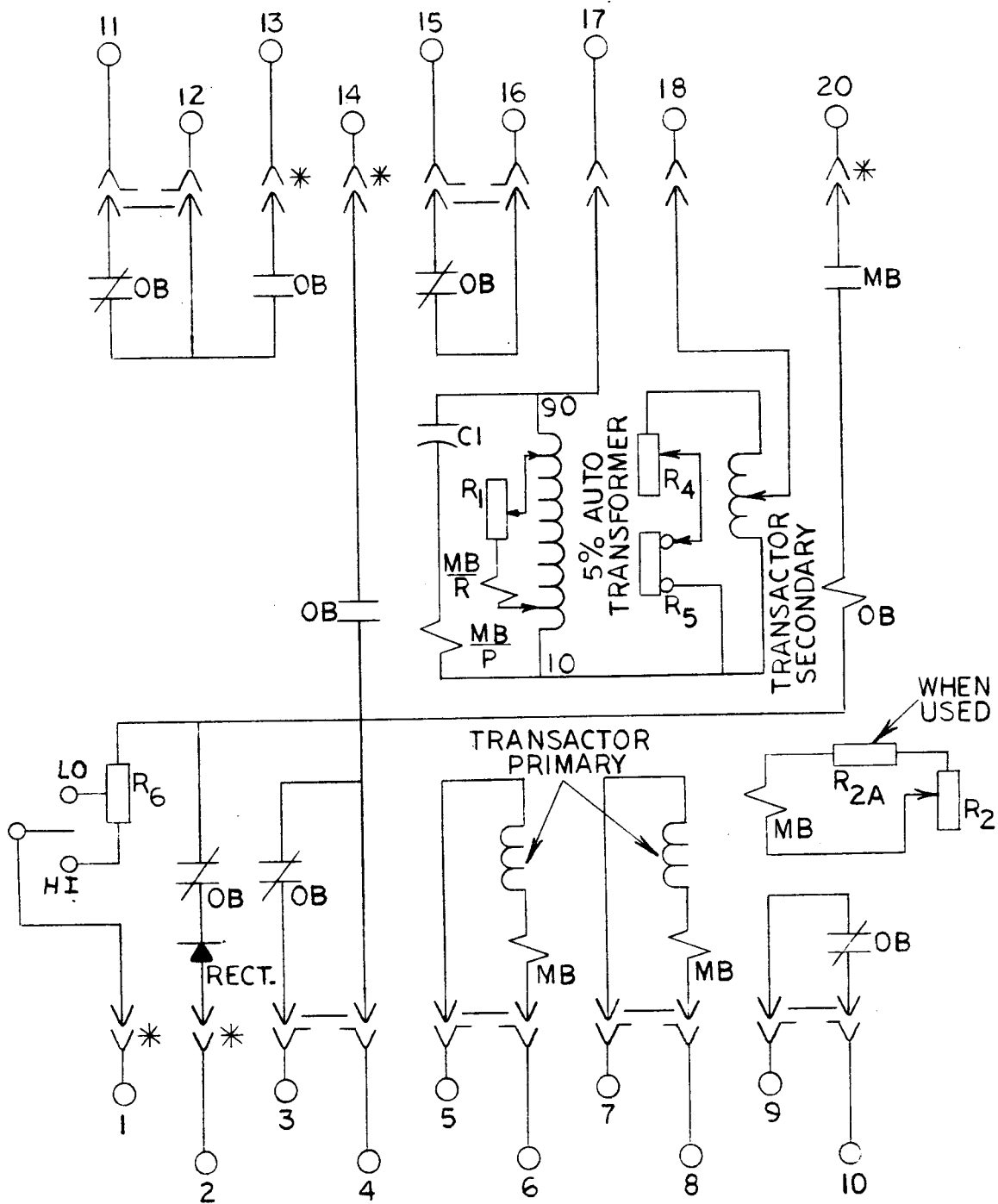

Figure 4 (0208A3909) Steady-State Accuracy of the MB Unit (with Offset) in the CEB51A Relay



NOTE: AFTER ENGAGING AUXILIARY BRUSH CONNECTING PLUG TRAVELS $\frac{1}{4}$ INCH BEFORE ENGAGING THE MAIN BRUSH ON THE TERMINAL BLOCK

Figure 5 (8025039) Cross Section of Drawout Case Showing Position of Auxiliary Brush and Shorting Bar



*=SHORT FINGER

* Figure 6 (0178A9134-3) Typical Internal Connections Diagram for the CEB51A Relay

*Revised since last issue

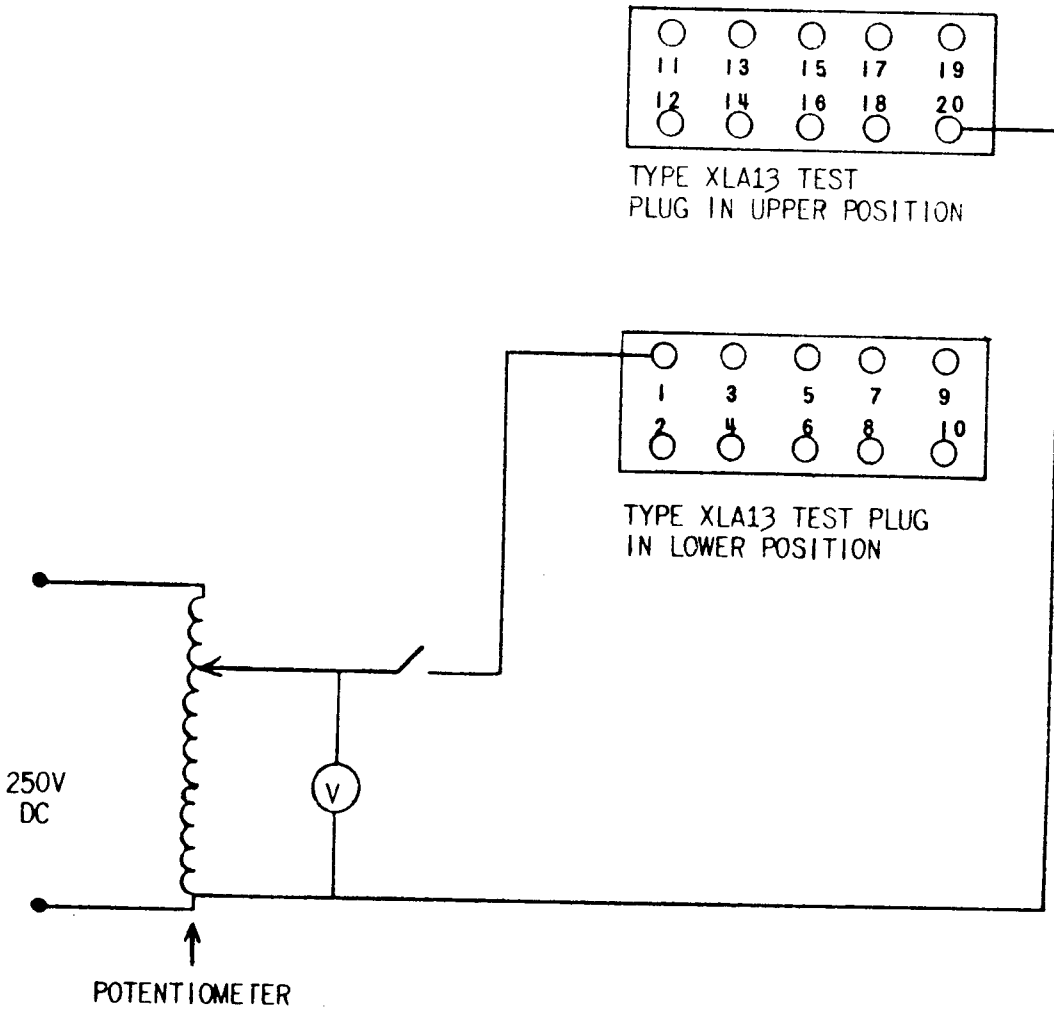

Figure 7 (0208A2406) Test Connections for Checking Pickup of the OB Unit of the CEB51A Relay

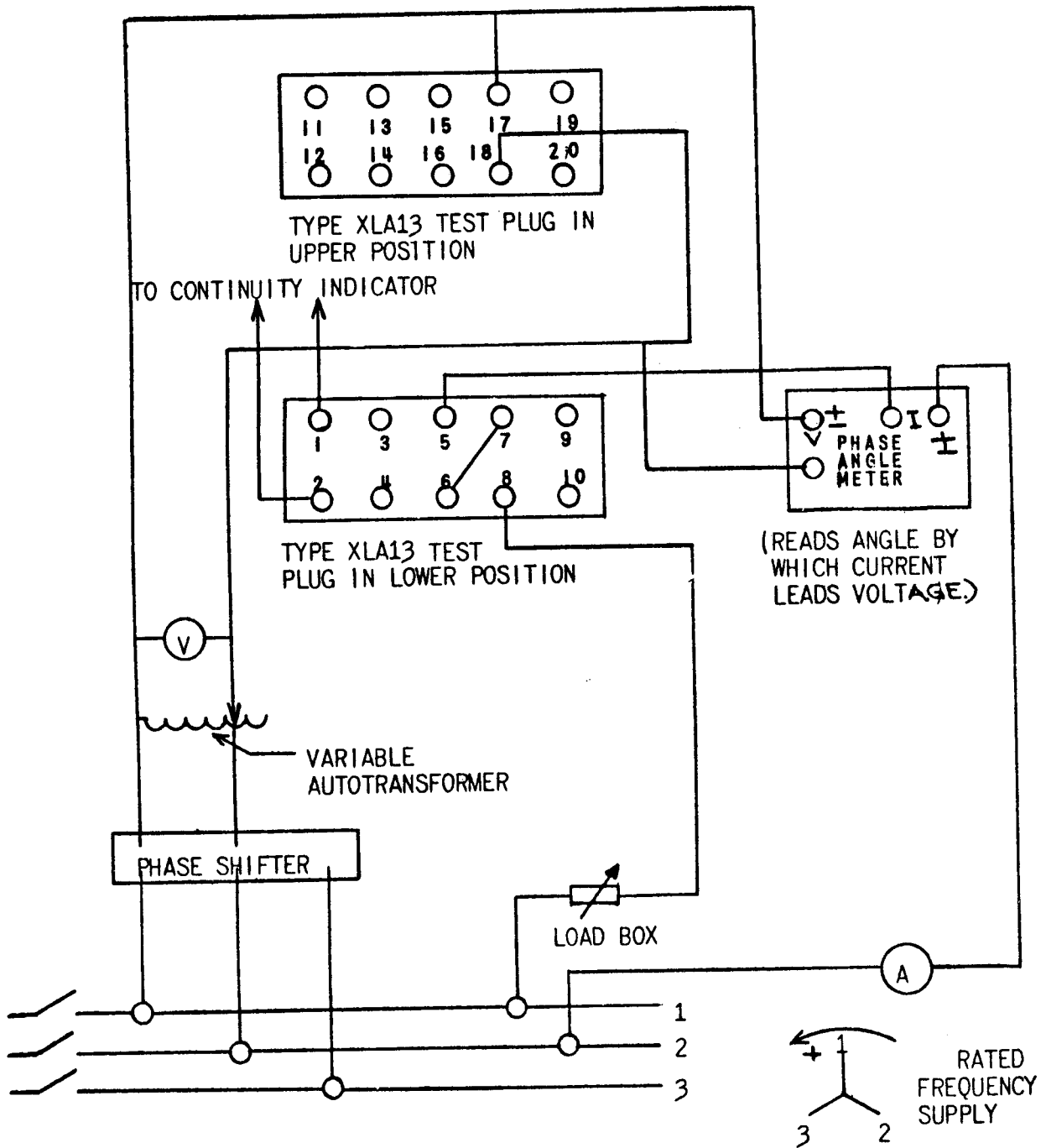

Figure 8 (0208A2407) Test-Connections Diagram for Checking Reach and Angle of Maximum Torque of CEB51A Relay

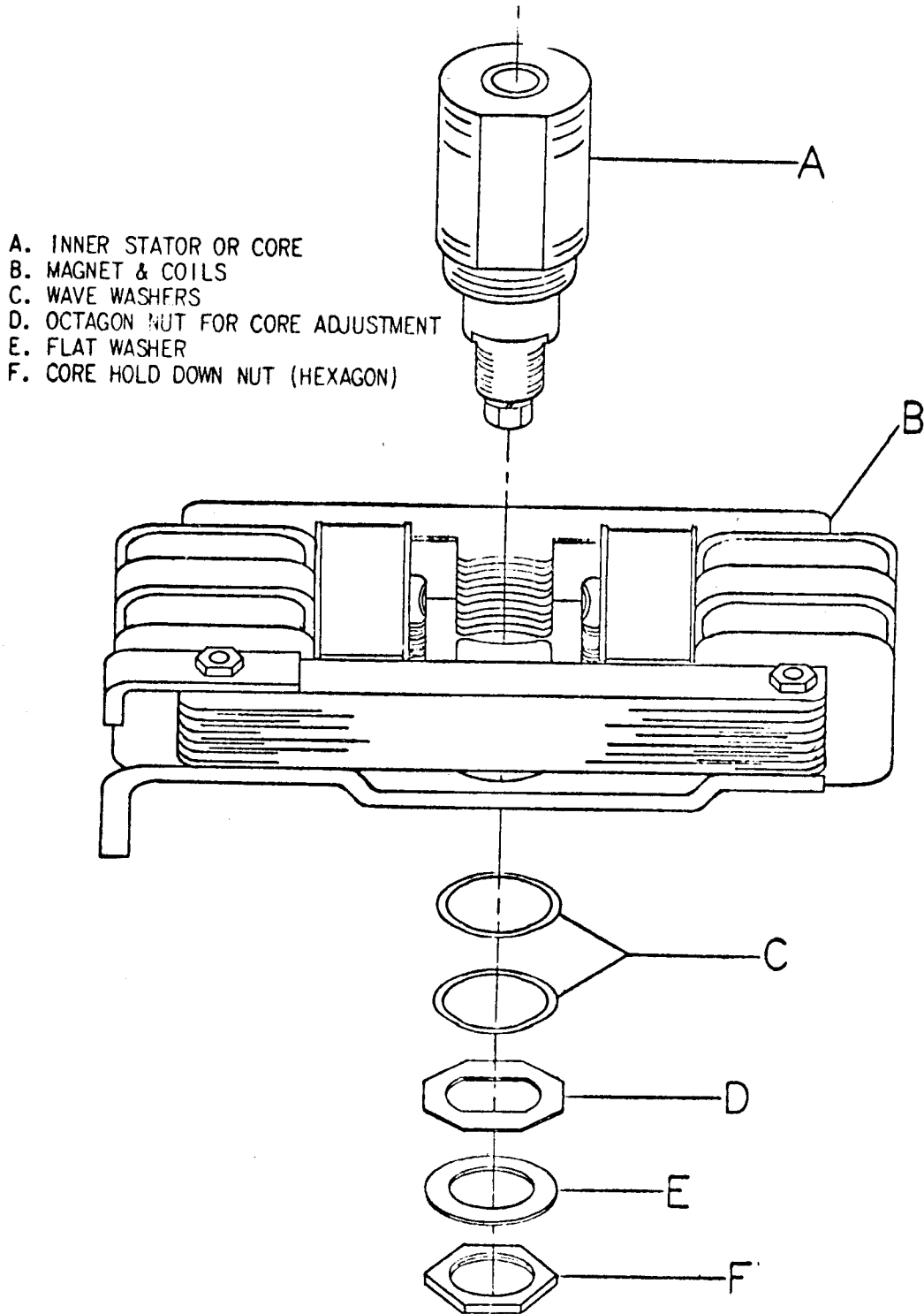

Figure 9 (0208A3583) Magnet and Coil Breakdown Illustration for the CEB51A Relay

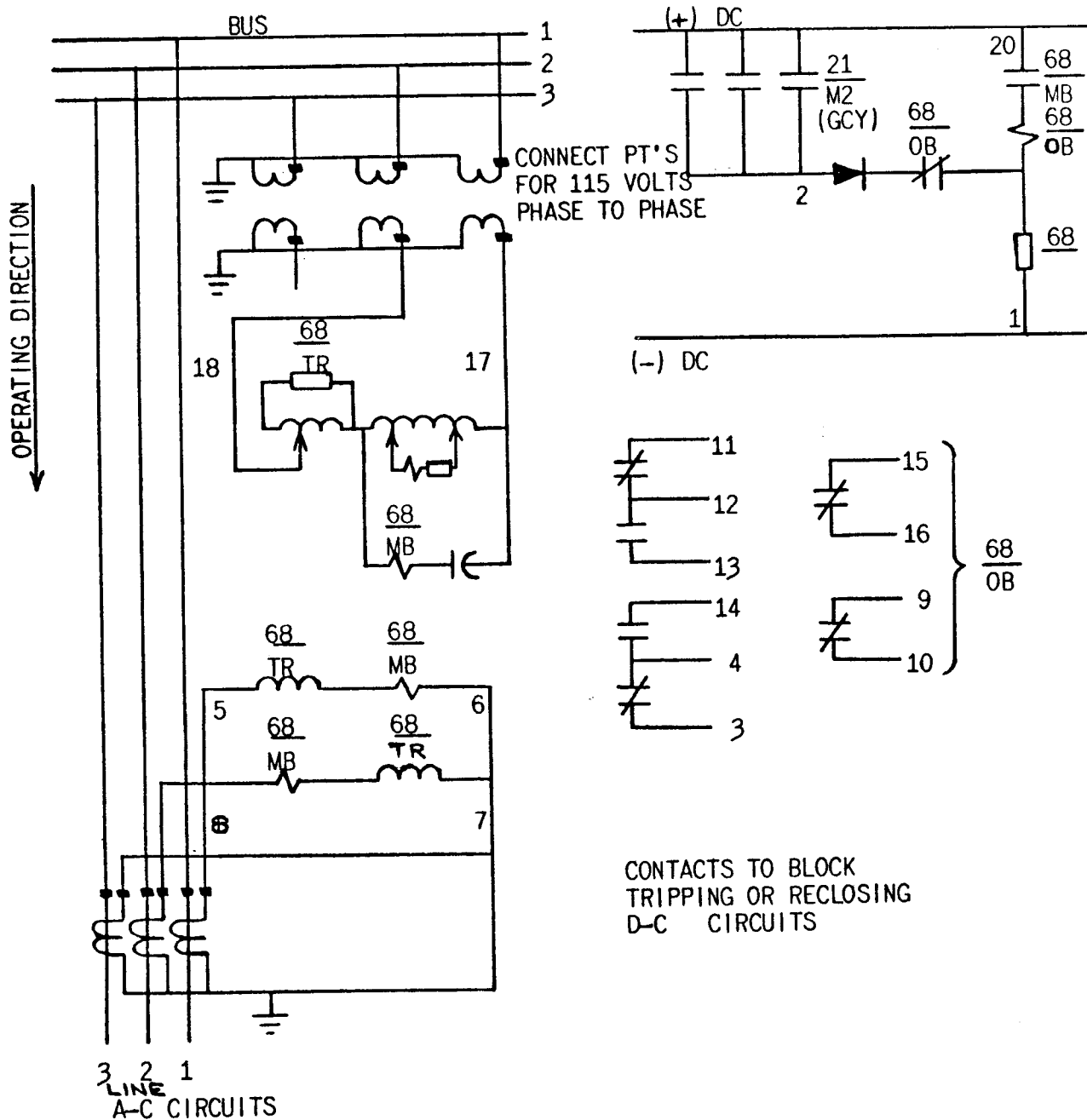
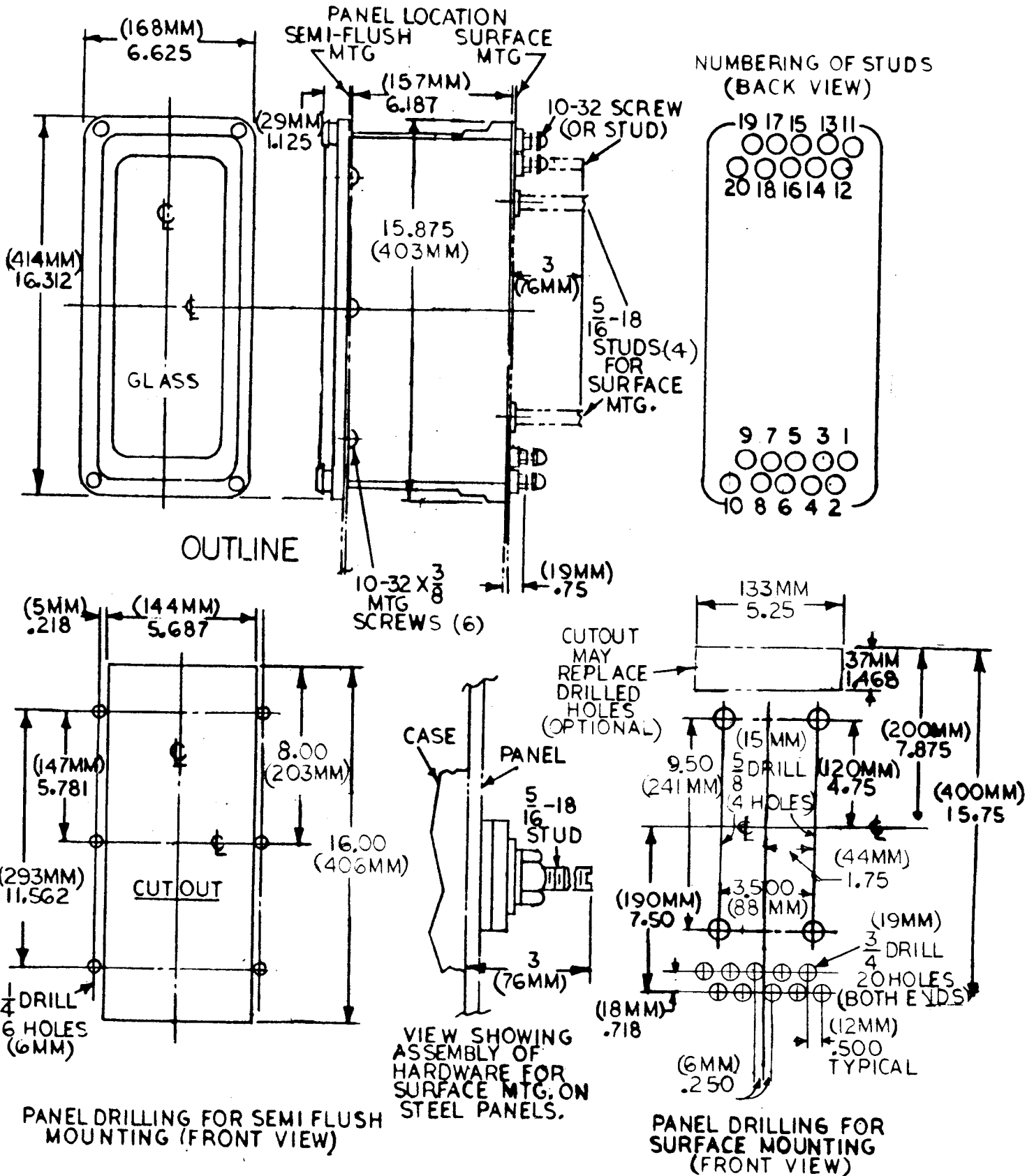

Figure 10 (0208A2405) Typical External-Connections Diagram for the CEB51A Relay



* Figure 11 (K620974-4) Outline and Panel-Drilling Dimensions for Drawout Relays, Size M2

*Revised since last issue



***Meter and Control
Business Department***