



# RECLOSING RELAYS

Type **NSR11C**  
**NSR11D**  
**NSR11E**  
**NSR11F**



# CONTENTS

SUBJECT	Page
INTRODUCTION.....	3
CHARACTERISTICS.....	3
RATINGS.....	
Contacts.....	<b>3</b>
RECEIVING, HANDLING AND STORAGE.....	3
DESCRIPTION.....	3
Case.....	5
INSTALLATION.....	5
Location.....	5
Mounting.....	5
Connection.....	5
OPERATION.....	5
FACTORS IN APPLICATION.....	5
Control Switches.....	5
Undervoltage Devices.....	<b>5</b>
Closing Control Circuits.....	
Latch-Checking Switches.....	10
Holding Coil Circuit.....	10
Overcurrent Relays.....	10
Interrupting Rating of Power Circuit Breakers.....	10
Typical External Connections.....	10
MAINTENANCE.....	10
Adjustments and Inspection.....	10
Periodic Testing.....	10
Contact Cleaning.....	10
Testing.....	10
RENEWAL PARTS.....	11

# RECLOSING RELAY TYPES NSR11C,D,E AND F

## INTRODUCTION

These relays are self resetting, "Single-shot" reclosing relays which initiate immediate reclosure of a power circuit breaker. The relays operate only if a predetermined time has elapsed since the last successful reclosure.

These relays are designed for use where single immediate reclosure of circuit breakers is desired. In the event the breaker reopens immediately after reclosure, indicating a continuation of abnormal conditions, the apparatus remains locked out. The relays are suited for use in applications where the requirements of continuity of service do not justify subsequent time reclosures, such as the Type NLR relay provides.

## CHARACTERISTICS

After the relay has operated to reclose a breaker, the relay will not operate again if the breaker does not remain closed for at least a pre-selected time of 3 to 20 seconds. This is the resetting time of the relay and is explained more completely under ADJUSTMENTS.

## RATINGS

The Type NSR11E and NSR11F relays are rated 48/125/250 volts DC. The Type NSR11C and NSR11D are rated 120/240 volts 25/50/60 cycles.

TABLE A  
CONTACT INTERRUPTING ABILITY

Volts	Interrupting Cap. (Amps) Inductive*
48 DC	1.0
125 DC	0.5
250 DC	0.25
115 - 60 Cyc.	0.75
230 - 60 Cyc.	0.5

\*Inductance of average trip coil. The non-inductive interrupting ratings for repetitive protective duty are approximately 2-1/2 times ratings shown in the table.

## CONTACTS

Current closing rating of the contacts is 30

amperes for voltages not exceeding 250 volts. The contacts have a current carrying rating of 3 amperes continuously or 30 amperes momentarily. Interrupting ratings for various voltages are given in the Table A.

## RECEIVING, HANDLING AND STORAGE

These relays, when not included as a part of a control panel will be shipped in cartons designed to protect them against damage. Immediately upon receipt of a relay, examine it for any damage sustained in transit. If injury or damage resulting from rough handling is evident, file a damage claim at once with the transportation company and promptly notify the nearest General Electric Apparatus Sales Office.

Reasonable care should be exercised in unpacking the relay in order that none of the parts are injured or the adjustments disturbed.

If the relays are not to be installed immediately, they should be stored in their original cartons in a place that is free from moisture, dust and metallic chips. Foreign matter collected on the outside of the case may find its way inside when the cover is removed and cause trouble in the operation of the relay.

## DESCRIPTION

The NSR11 relays contain a telephone-type relay unit which has a coil with two separate equal windings, a rheostat (with locking nut) to select the relay reset time interval, a selecting link to select the voltage rating, a timing capacitor, a zener type voltage regulator to maintain constant voltage across the timing capacitor and adjusting rheostat, a discharge resistor and additional resistors as required.

The NSR11C AND NSR11D relays are A.C. models and contain a silicon diode and a filter capacitor in addition to the above listed components.

The NSR11F and NSR11D relays are similar to the NSR11E AND NSR11C models respectively except for the addition of an electric target.

*These instructions do not purport to cover all details or variations in equipment nor to provide for every possible contingency to be met in connection with installation, operation or maintenance. Should further information be desired or should particular problems arise which are not covered sufficiently for the purchaser's purposes, the matter should be referred to the General Electric Company.*

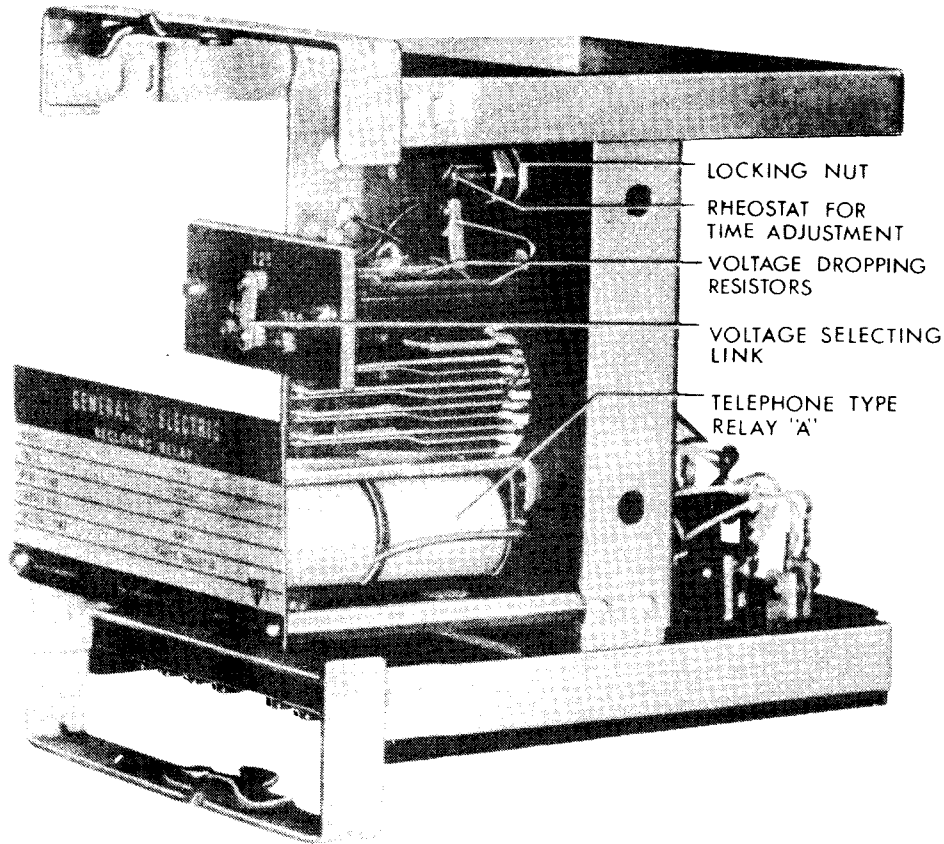
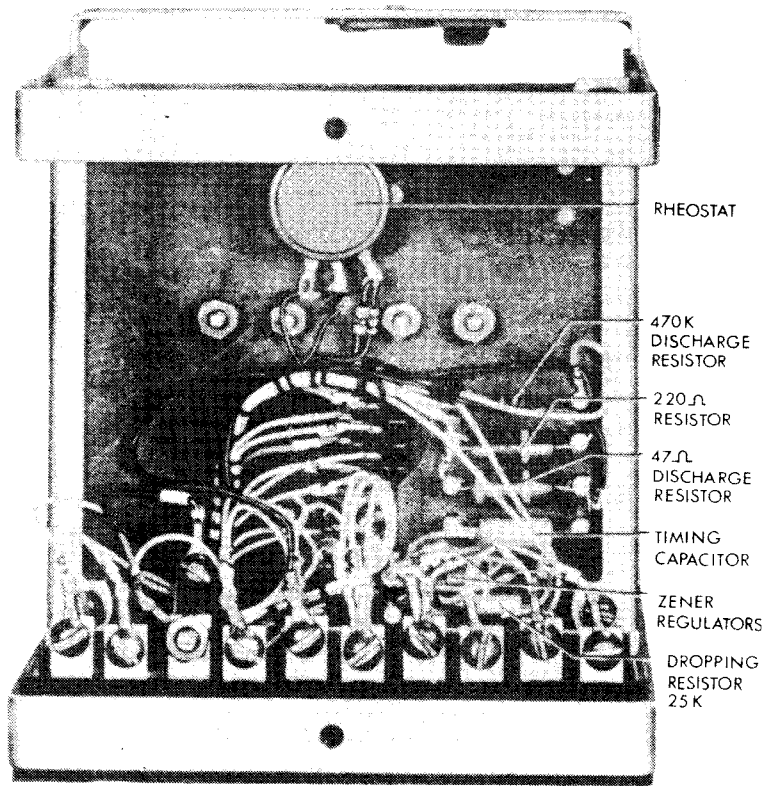

Fig. 1A (8039515) 3/4 Front View.



1B. (Rear View)

Fig. 1 (8039514) Front and Rear View of the NSR11 Relay Removed from Case.

## CASE

The case is suitable for either surface or semiflush panel mounting and an assortment of hardware is provided for either mounting. The cover attaches to the case and also carries the reset mechanism when one is required. Each cover screw has provision for a sealing wire.

The case has studs or screw connections at the bottom only for the external connections. The electrical connections between the relay units and the case studs are made through spring backed contact fingers mounted in stationary molded inner and outer blocks between which nests a removable connecting plug which completes the circuits. The outer block, attached to the case, has the studs for the external connections, and the inner block has the terminals for the internal connections.

The relay mechanism is mounted in a steel framework called the cradle and is a complete unit with all leads being terminated at the inner block. This cradle is held firmly in the case with a latch at the top and the bottom and by a guide pin at the back of the case. The cases and cradles are so constructed that the relay cannot be inserted in the case upside down. The connecting plug, besides making the electrical connections between the respective blocks of the cradle and case, also locks the latch in place. The cover, which is fastened to the case by thumbscrews, holds the connecting plug in place.

To draw out the relay unit the cover is first removed, and the plug drawn out. The latches are then released, and the relay unit can be easily drawn out. To replace the relay unit, the reverse order is followed.

A separate testing plug can be inserted in place of the connecting plug to test the relay in place on the panel either from its own source of current and voltage, or from other sources. Or, the relay unit can be drawn out and replaced by another which has been tested in the laboratory.

The cover is provided with a mechanical interlock which prevents replacing the cover unless the connecting plug is in place.

## INSTALLATION LOCATION

The location should be clean and dry, free from dust and excessive vibration, and well lighted to facilitate inspection and testing.

## MOUNTING

The relay should be mounted on a vertical surface. The outline and panel diagram is shown in Fig. 8.

## CONNECTIONS

Internal connection diagram is shown in Fig. 2, 3, 4, & 5. Typical wiring diagram is given in Fig. 3. Note that terminals #3 and #4 must be connected to positive.

## OPERATION

The operation of these relays may be easily understood by referring to Fig. 6. When the circuit breaker (152) is closed, the capacitor (79/CAP) is charged from the control circuit through the charging rheostat, (79/RHEO) and a contact of the control switch (01/CS). When the circuit breaker is tripped on overcurrent, the initiating contact which may be a breaker auxiliary switch (152b) connects the operating coil of the relay (79/OC) across the capacitor. Blocking contacts can be used to prevent reclosing when desired as indicated. The capacitor discharge picks up the relay, which seals itself in by means of its holding coil (79/HC), and energizes the breaker closing circuit. When the 79 relay picks up, it also completely discharges the capacitor to insure full reset time after every operation. When the breaker closes, the breaker (52Y) contact or equivalent opens the holding coil circuit and the relay drops out. If the breaker remains closed as long as the resetting time of the relay or longer, the capacitor is again charged and the relay is ready for another operation, as described above. However, if a subsequent opening of the breaker has occurred before the resetting time of the relay, the capacitor will not have attained a sufficient charge to pick up the relay and reclose the breaker. Reclosing of the breaker must then be accomplished by some other means.

## FACTORS IN APPLICATION

### CONTROL SWITCHES

By referring to Fig. 6, it will be observed that a three-stage Type SB-1 control switch (Model 16SB1B9) should be provided where these relays are furnished. The control switch diagram is shown in Fig. 6. This switch has extra contacts which prevent the Type NSR11 relay from reclosing the breaker after it has been tripped by means of the control switch. If tripped in this manner, the breaker must be reclosed by the control switch before the automatic reclosing feature is restored.

### UNDERVOLTAGE DEVICES

In order to obtain full advantage of immediate initial reclosure, undervoltage devices used on circuits reclosed by the Type NSR11 relays should have a one or two second time delay. This prevents shutting down of motors during the reclosing period.

### CLOSING CONTROL CIRCUITS

Where the Type NSR11 relays are used, it is essential that the solenoid mechanisms have closing circuits which insure complete closure of the breaker even though the auxiliary switch on the breaker mechanism opens before closure is complete.

Where trip-free closing relays are used, it is necessary that they reset quickly enough to permit immediate reclosure of the breaker.

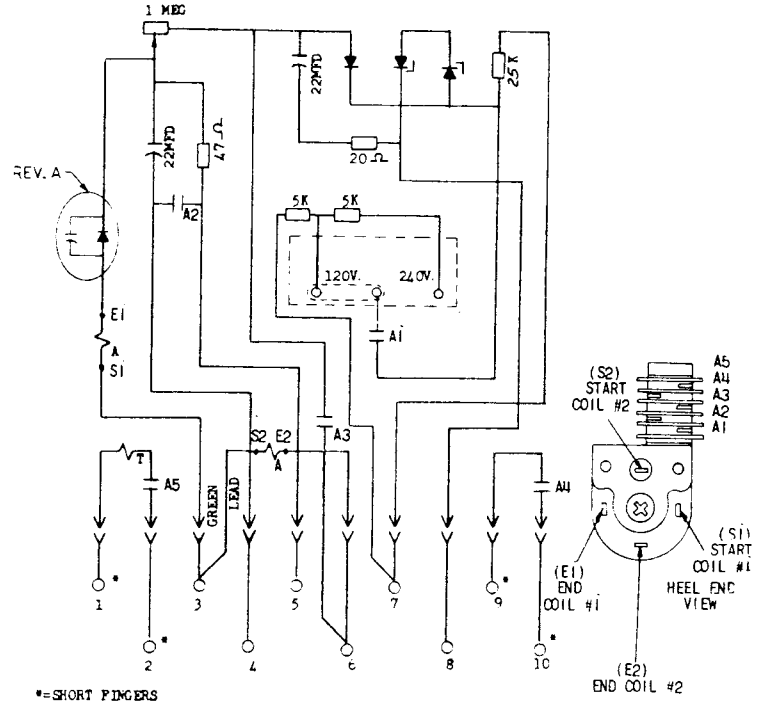
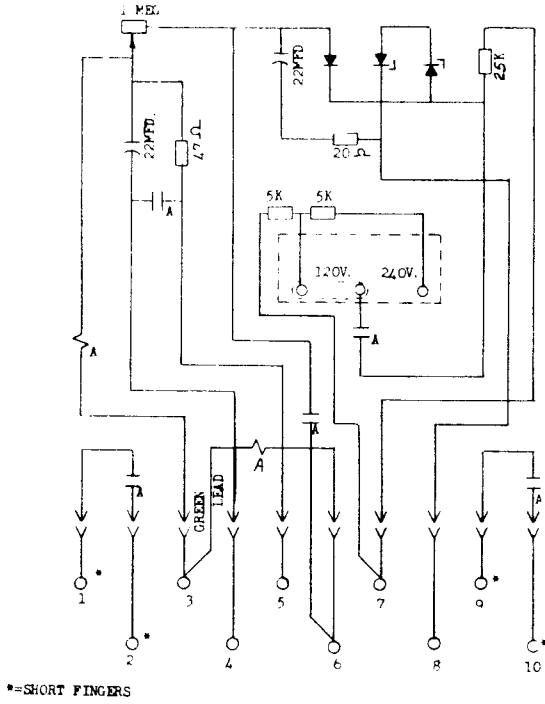
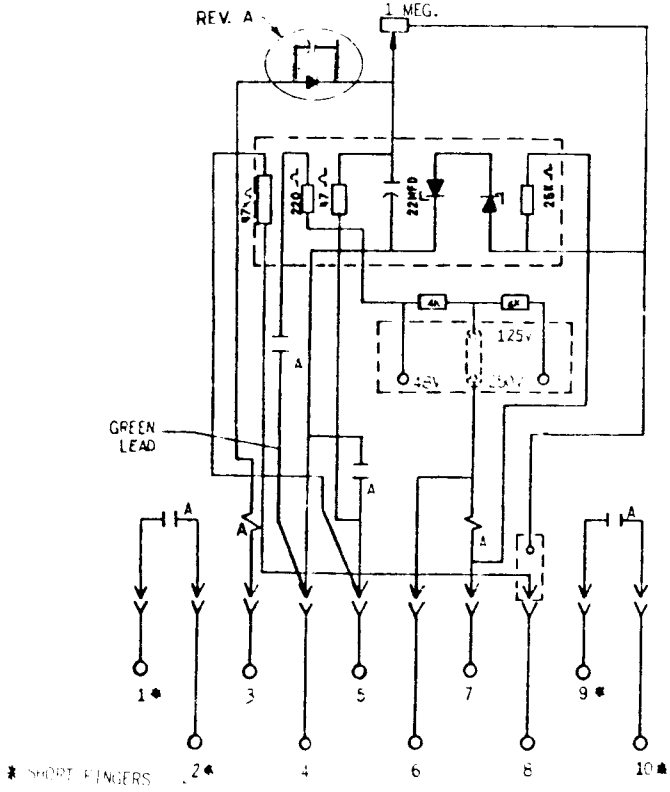
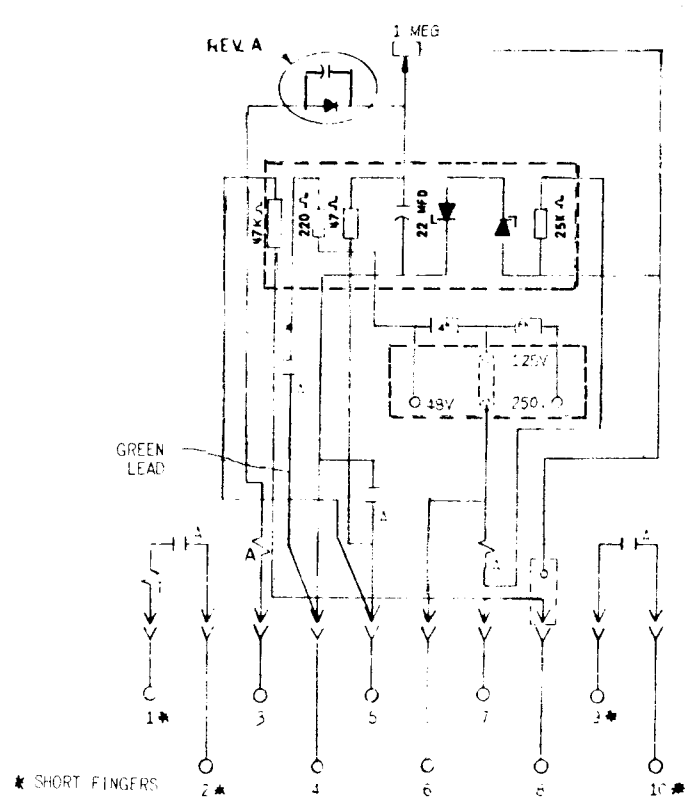

Fig. 2 (0178A9191-1) Internal Connection Diagram For Relay Type NSR11C.

\* Fig.3 (0178A9177[2]) Internal Connection Diagram For Relay Type NSR11D.



\* Fig. 6 (0208A2457[A]) Internal Connection Diagram For Relay Type NSR11E.



\* Fig. 5 (0208A2456[A]) Internal Connection Diagram For Relay Type NSR11F.

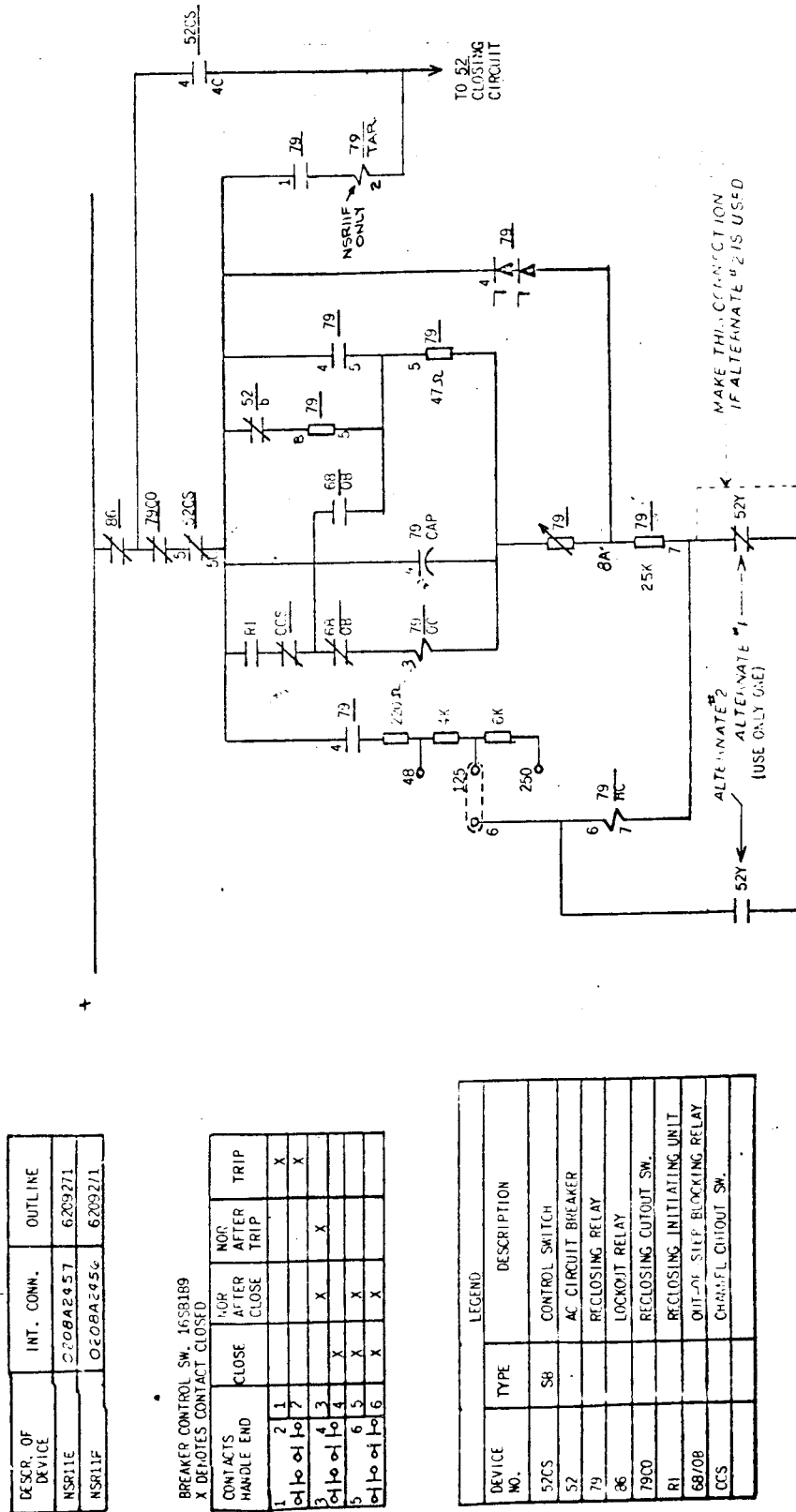

DESCR. OF DEVICE	INT. CONN.	OUTLINE
NSRIIE	220BA2457	6209271
NSRIIF	020BA2456	6209271

BREAKER CONTROL SW. 165B189  
X DENOTES CONTACT CLOSED

CONTACTS HANDLE	CLOSE	FOR AFTER CLOSE	NOR AFTER TRIP	TRIP
1				
2				X
3	X	X	X	X
4	X	X	X	
5	X	X	X	
6	X	X	X	
7	X	X	X	

DEVICE NO.	TYPE	DESCRIPTION
57CS	S8	CONTROL SWITCH
52		AC CIRCUIT BREAKER
79		RECLOSING RELAY
86		LOCKOUT RELAY
79C0		RECLOSING CUTOFF SW.
RI		RECLOSING INITIATING UNIT
68/08		OUT-OF-STEP BLOCKING RELAY
CCS		CHANNEL CUTOFF SW.

\* Fig. 6A (0165A2213[2]) Typical External Connection Diagram for NSRIIE and NSRIIF Relays. (DC Control) Reclosure Initiated by RI Unit.

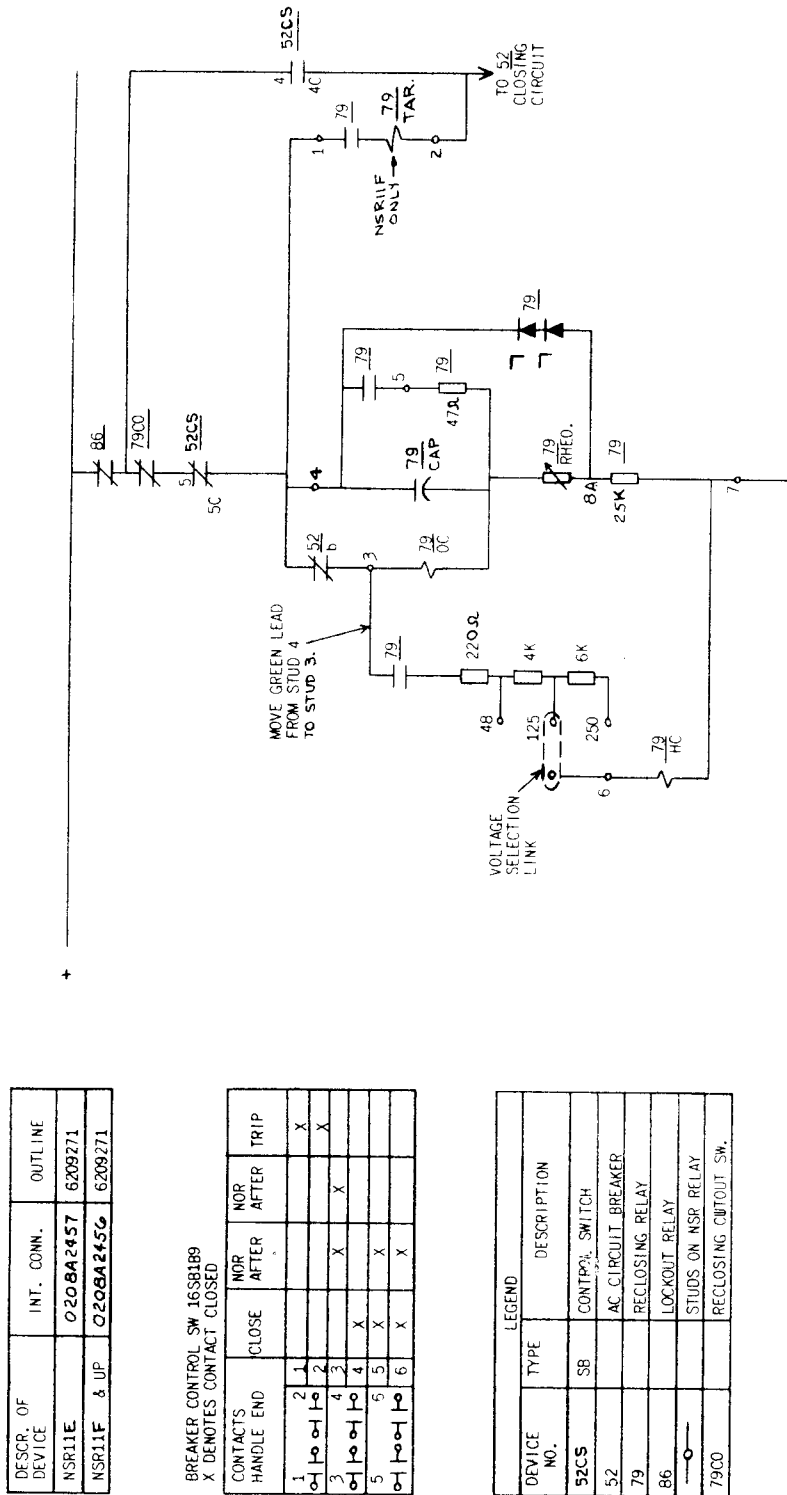

DESCR. OF DEVICE	INT. CONN.	OUTLINE
NSRIIE	020BA2457	6209271
NSRIIF & UP	020BA2456	6209271

BREAKER CONTROL SW 16SB189  
X DENOTES CONTACT CLOSED

CONTACTS HANDLE END	CLOSE	NOR AFTER	NOR AFTER	TRIP
1				X
2				X
3	X		X	
4	X		X	
5	X		X	
6	X		X	

LEGEND	
DEVICE NO.	DESCRIPTION
52CS	CONTROL SWITCH
52	AC CIRCUIT BREAKER
79	RECLOSING RELAY
86	LOCKOUT RELAY
	STUDS ON NSR RELAY
79CO	RECLOSING OUTPUT SW.

Fig. 6B (0165B2205-1) Typical External Connections Diagram for the NSRIIE and NSRIIF Relay. (DC Control) Reclosure Initiated by the Breaker Auxiliary Switch.

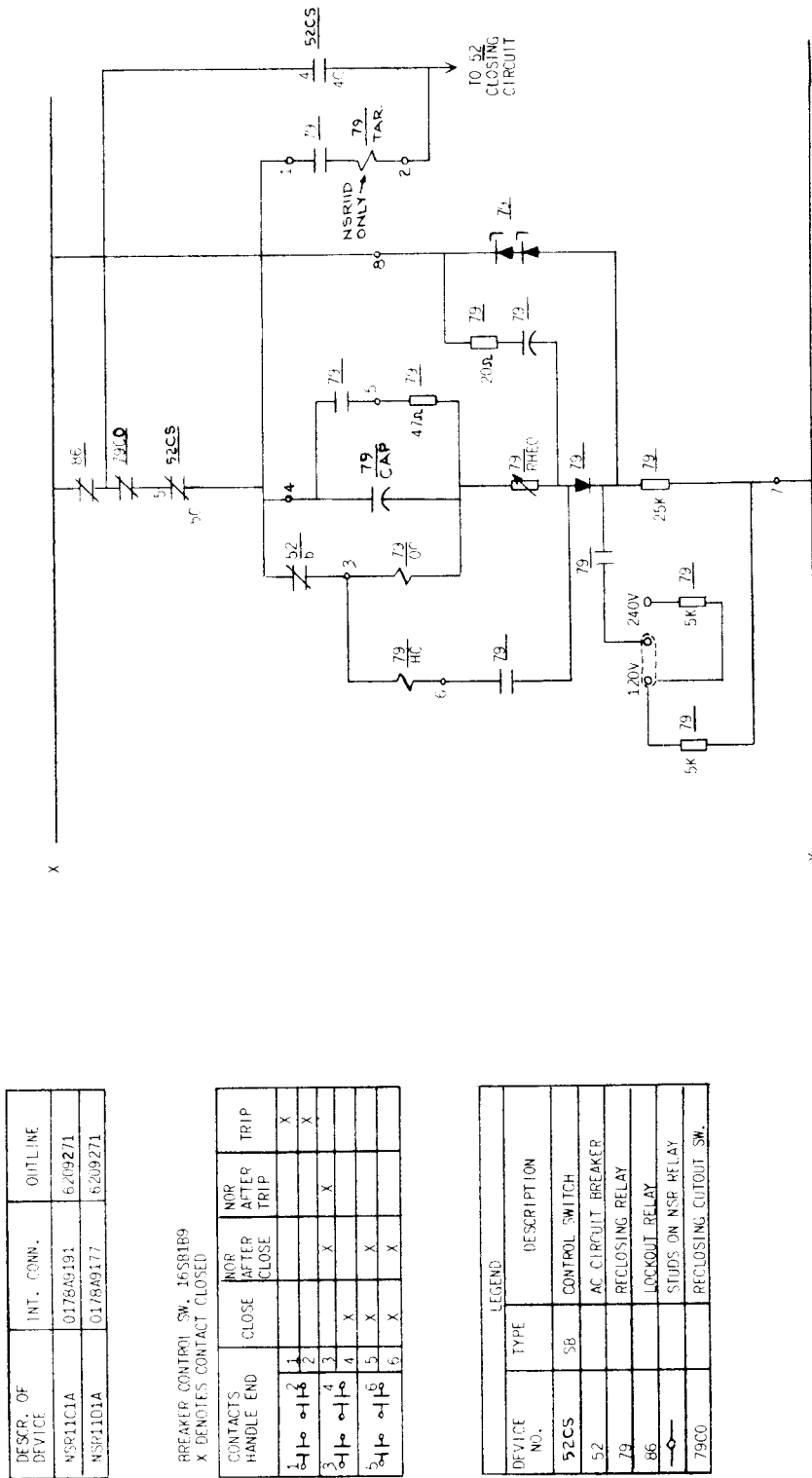

DESCR. OF DEVICE	INT. CONN.	OUTLINE
NSR11C1A	0178A9191	6209271
NSR1101A	0178A9177	6209271

BREAKER CONTROL SW. 16SR1B9  
X DENOTES CONTACT CLOSED

CONTACTS HANDLE END	CLOSE		NDR AFTER CLOSE	NDR AFTER TRIP
	1	2		
1	X			X
2				X
3		X	X	
4		X		
5	X	X	X	
6	X	X	X	

LEGEND	
DEVICE NO.	DESCRIPTION
52CS	CONTROL SWITCH
79	AC CIRCUIT BREAKER
86	RE-CLOSING RELAY
79CO	LOCKOUT RELAY
	STUDS ON NSR RELAY
	RE-CLOSING CIRCUIT SW.

Fig. 6C (0165B2206-0) Typical External Connections Diagram for the NSRIIC and NSRIID Relays. (AC Control) Reclosure Initiated by the Breaker Auxiliary Switch.

## LATCH-CHECKING SWITCHES

In order to insure successful operations of breakers reclosed by Type NSR11 relays, it is necessary to add a latch-checking switch to all trip-free solenoid mechanisms. This switch completes the closing circuit only after the mechanism latch is properly reset for the reclosure. Latch-checking switches are not required for non-trip-free solenoid mechanisms.

## HOLDING COIL CIRCUIT

This circuit must be complete (except for the relay's own contact) no later than the instant when the operating coil becomes energized, and must remain complete until reclosure has progressed to the point where it will carry through even if the reclosing relay opens the closing circuit.

## OVERCURRENT RELAYS

The protective relays that trip the breaker obviously must open their contacts before the breaker recloses; otherwise, the breaker may even trip a second time even though the fault has cleared. Some of the superseded types of induction relays are not satisfactory for use with the Type NSR11 relays. Refer such cases to the General Electric Apparatus Sales Office for recommendations and prices.

## INTERRUPTING RATING OF POWER CIRCUIT BREAKERS

The derating factors applying to the interrupting ratings of breakers should be checked for all application of Type NSR11 relays. This is given in ASA Standard C37.7-1960.

## TYPICAL EXTERNAL CONNECTIONS

Typical external connections for NSR relays are shown in Figs. 6A, 6B, and 6C. Fig. 6A shows the connections for the NSR11E or NSR11F with DC control voltage and with the reclosure initiated by the RI unit in the primary protective relaying. Fig. 6B shows connections for the NSR11E or NSR11F DC connections, with reclosure initiated by one breaker auxiliary contact. Note that in Fig. 6B it is necessary to shift the green lead from stud 4 to stud 3.

Fig. 6C shows typical external connections for the NSR11C and NSR11D, AC control, with reclosure initiated by a breaker auxiliary switch.

# MAINTENANCE

## ADJUSTMENTS AND INSPECTION

The relay has been adjusted at the factory but if a check shows that the adjustments have been disturbed, the following adjustments may be made to restore the desired operation.

With the telephone type relay deenergized each normally open contact should have a gap of .010"-.015". Observe the wipe on each normally closed contact by deflecting the stationary contact member towards the frame. Wipe should be approximately .005". The contact in series with the holding coil must make slightly ahead of the other contacts.

Resetting time of the relay is the time required for the capacitor to absorb sufficient energy to operate or pickup, the relay unit. This time can be varied by means of the rheostat between 3 and 20 seconds. The locking nut should be retightened after any change in the reset time. The reset time is not affected by changes in the supply voltage.

## PERIODIC TESTING

These relays should be checked for operation at regular intervals, preferably at the same time that the associated protective devices are inspected. The settings should not require readjustment, but if changes are necessary the points discussed under ADJUSTMENT AND INSPECTION should be observed.

## CONTACT CLEANING

For cleaning relay contacts, a flexible burnishing tool should be used. This consists of a flexible strip of metal with an etched roughened surface, resembling in effect a superfine file. The polishing action is so delicate that no scratches are left, yet corroded material will be removed rapidly and thoroughly. The flexibility of the tool insures the cleaning of the actual points of contact.

Relay contacts should not be cleaned with knives, files, or abrasive paper or cloth. Knives or files may leave scratches which increase arcing and deterioration of the contacts. Abrasive paper or cloth may leave minute particles of insulating abrasive material in the contacts and thus prevent closing.

The burnishing tool described above can be obtained from the factory.

## TESTING

A convenient test circuit for the Type NSR11 relay is shown in Fig. 7.

Starting with zero charge on Capacitor, switch S-2 is closed starting the timer and charging capacitor.

When the timer indicates the resetting time, S-1 is closed in the test position and the relay should pick up. The timer will record the exact charging time. If the relay does not pick up throw S-1 to discharge position momentarily, then open S-1 and repeat adjusting rheostat, if necessary.



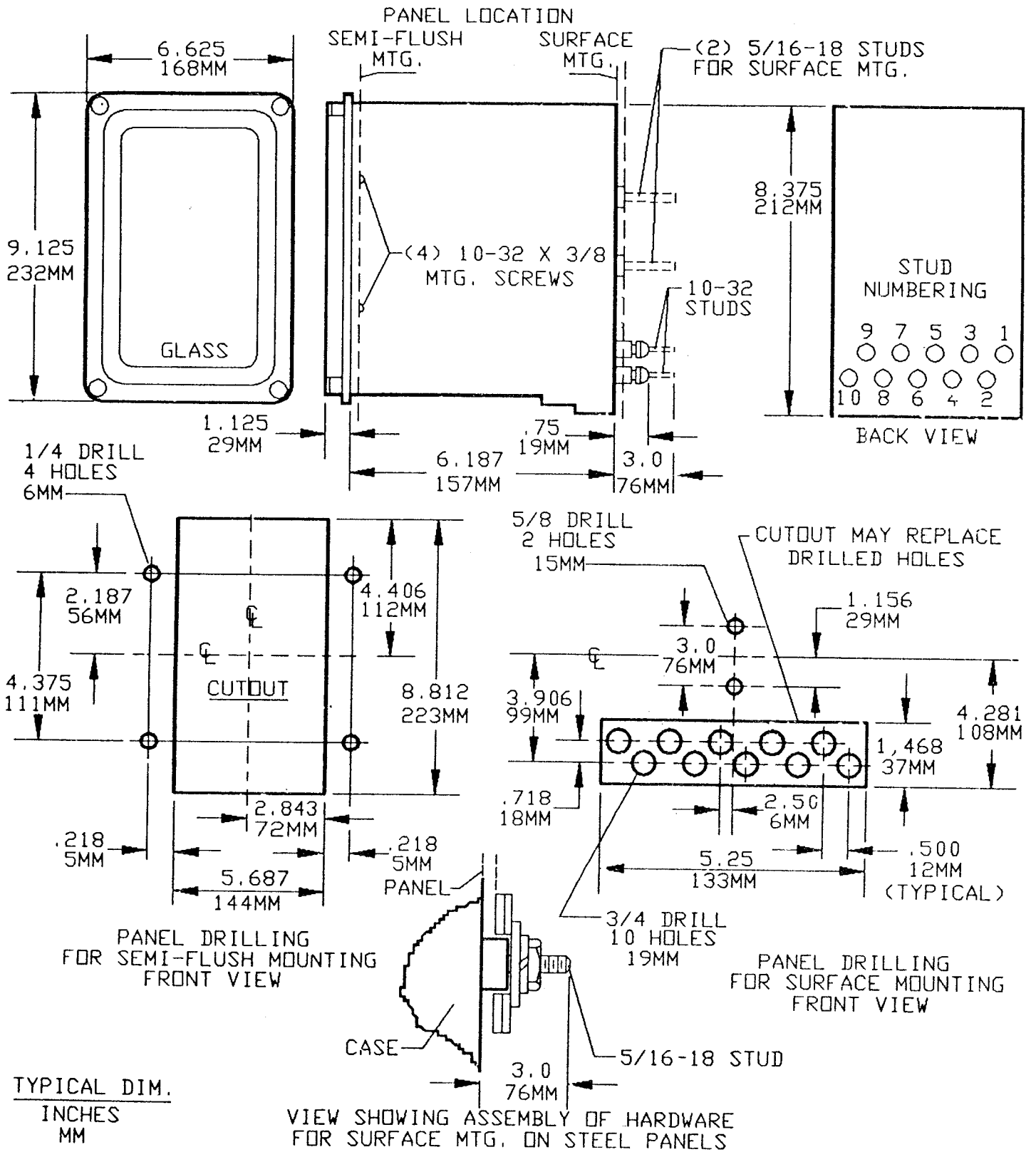

\* Fig. 8 (6209271 [8]) Outline and Panel Drilling Dimensions for NSR11 Relays.

\* Revised since last issue