

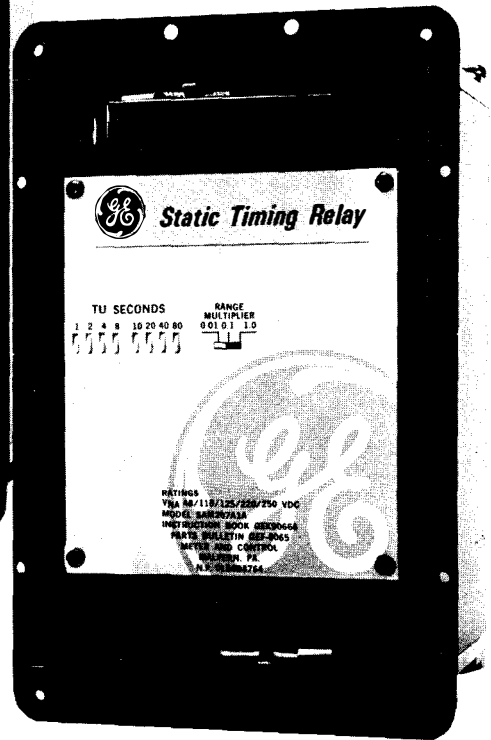

# INSTRUCTIONS

## Static Timing Relays

- SAM201
- SAM202
- SAM203
- SAM204
- SAM205
- SAM206
- SAM207

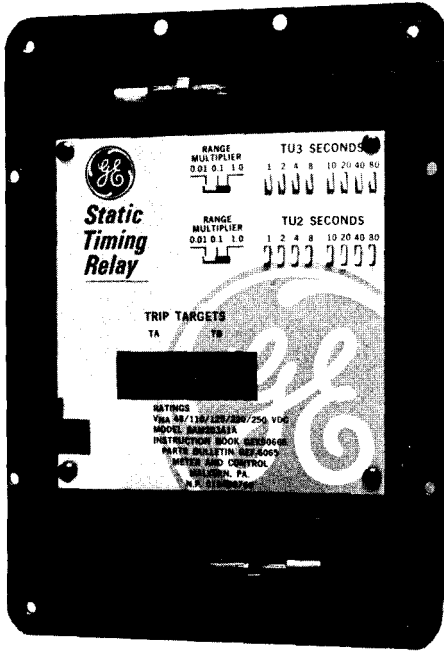

GE Protection and Control  
 205 Great Valley Parkway  
 Malvern, PA 19355-1337

www.electricalmanuals.com

CONTENTS

	Page
<b>Description</b>	3
<b>Application</b>	3
<b>Specifications</b>	5
DC control voltage	5
Settings	5
Accuracy	5
Overshoot	5
Ride-Thru Time	5
Environmental	5
<b>Ratings</b>	6
Burden	6
Contacts	6
Target	6
<b>Settings</b>	6
<b>Displays</b>	7
<b>Functional Description</b>	7
<b>Construction</b>	8
<b>Receiving, Handling and Storage</b>	8
<b>Acceptance Tests</b>	8
General	8
Visual	8
Test Equipment	9
General Testing Consideration	9
Tests	9
Timing test	10
Target test	10
<b>Installation Procedure</b>	10
Surge ground	10
Electrical tests	11
Settings	11
<b>Periodic checks and routine maintenance</b>	11
<b>Servicing</b>	11
<b>Renewal parts</b>	12
<b>Trouble shooting</b>	14
Timer Board Functional Description	15
Problems and Solutions	16
<b>List of Figures</b>	17

Cover photos (8043819,820,820)

*These instructions do not purport to cover all details or variations in equipment nor to provide for every possible contingency to be met in connection with installation, operation or maintenance. Should further information be desired or should particular problems arise which are not covered sufficiently for the purchaser's purposes, the matter should be referred to the General Electric Company.*

*To the extent required the products described herein meet applicable ANSI, IEEE and NEMA standards, but no such assurance is given with respect to local codes and ordinances because they vary greatly.*

## STATIC TIMING RELAYS

### TYPE SAM 201,202,203,204,205,206 & 207

#### DESCRIPTION

The SAM200 relays provide accurate and repeatable timing functions that produce a contact closure after a selected time delay has expired. The time-delay settings are made using toggle switches mounted on the front plate of the relay, as explained in the SETTINGS section. The total time delay consists of the set time delay added to the operating time of the output relay. The operating time of the output relay, typically 2-6 milliseconds as shown in Figure 39, will only be significant at the low end of the time-delay setting range.

Table I summarizes the models available.

Table I			
<u>Model</u>	<u>Case Size</u>	<u>Timing Functions</u>	<u>Trip Targets</u>
201	S1	TU	TA & TB
202	S1	TU	NONE
203	S1	TU2&TU3	TA & TB
204	S1	TU2&TU3	NONE
205	S1	TU	T1 & T2
206	S1	TU2&TU3	T1,T2&T3
207	S2	TU	NONE

External connection diagrams for the above models are shown in Figures 1 through 7.

#### APPLICATION

The SAM200 relays are applied wherever accurate and repeatable timing functions are required. The basic timing function is the same for all models of the SAM200 family, but each model is different based on the number of timing functions present, the presence or absence of targets, and the contact arrangement. This differentiation makes certain models more suited for specific applications. Table II on the next page lists the models and their recommended applications.

**TABLE II**

SAM201	General purpose
SAM202	General purpose 2 zone step distance schemes for line protection using zone-packaged distance relays
SAM203	General purpose 3 zone step distance schemes for line protection
SAM204	3 zone step distance schemes for line protection using zone-packaged distance relays
SAM205	2 zone step distance schemes for line protection using phase-packaged distance relays
SAM206	3 zone step distance schemes for line protection using phase-packaged distance relays
SAM207	General purpose

The application category "general purpose" in Table II includes use of the appropriate SAM200 relay for the timing function associated with local breaker-failure backup schemes. The term "phase-packaged" refers to component distance relays where the measuring units for all required zones associated with one phase or phase-pair are included in one relay case. An example of a phase-packaged distance relay is the GCY51A. The term "zone-packaged" refers to component distance relays where the measuring units for all 3 phases or phase-pairs associated with one zone are included in one relay case. An example of a zone-packaged distance relay is the CEY52A.

Figure 40 shows the SAM202 relay used in a breaker-failure scheme. Figure 41 shows a SAM202 used in a 2 zone step distance scheme with CEY and CEB distance relays. Figure 42 shows a SAM204 used in a 3 zone step distance scheme with CEY and CEB distance relays. Figure 43 shows a SAM206 used in a 3 zone step distance scheme with GCY51 distance relays.

## SPECIFICATIONS

### DC Control Voltage

Nominal 48, 110, 125, 220, 250  
 Minimum 37 Volts  
 Maximum 280 Volts

### Settings

#### Timing

Range Multiplier: 0.01  
 Recommended Timing Range: 0.03 to 0.99 seconds in 0.01 second steps  
 Repeatability:  $\pm 1.5\%$

Range Multiplier: 0.1  
 Recommended Timing Range: 0.10 to 9.90 seconds in 0.10 second steps  
 Repeatability:  $\pm 0.75\%$

Range Multiplier: 1.0  
 Recommended Timing Range: 1.0 to 99.0 seconds in 1.00 second steps  
 Repeatability:  $\pm 0.25\%$

### Accuracy

$\pm 3\text{msec.}$  or  $\pm 3\%$  of selected setting, whichever is greater.

### Overshoot (Overtravel)

5msec. (Relative to the actual measured time.)

### Ride-Thru Time

3msec. Ride-Thru time is defined as the ability of the SAM Relay to operate properly when it is energized by an initiating pulse of  $250\mu\text{sec}$  followed by an off time of 3msec. after which a continuous signal is applied until the relay operates.

### Reset Time

When the relay is timing out, but not picked up, the reset time is 9 mSec.  
 When the relay has timed out, and is picked up, the reset time is 3 mSec.

### Environmental

Operating  
 $-20^{\circ}\text{C}$  to  $+65^{\circ}\text{C}$  95% relative humidity (noncondensing)

Storage  
 $-40^{\circ}\text{C}$  to  $+75^{\circ}\text{C}$  95% relative humidity (noncondensing)

Surge  
 ANSI C37.90 (SWC and Fast Transient)  
 GE RFI  
 IEC 255

## RATINGS

## Burden

Table III

Model	Power Supply Burden DC WATTS		
	48	125	250
201,202 & 205	1.1	3.0	6.3
203	2.3	6.3	13.5
204 & 206	1.8	4.7	9.8
207	2.4	6.5	13.9

## Contact ratings

Make and carry 30 amps for 1 second. Trip rated per ANSI C37.90.  
Break 50 VA resistive, 25 VA inductive (L/R=40 msec) at 125/250 VDC.

## Target ratings

The operate level of a target unit is 150ma, with less than 2.0 volt drop at 30 amps.  
30 Amps for 1 sec., 5 Amps continuous, both with diode bridge.

## SETTINGS

The following settings, which must be set in each application, are made from the front of the relay without the need for pulling boards or removing the nameplate. It is only necessary to remove the front cover from the relay.

## "TU" or "TU2" &amp; "TU3" Seconds

An eight-position toggle switch(es), in conjunction with the Range Multiplier switch, is used to select the desired output delay setting. The setting is equal to the sum of the switch segments that are set in the UP position. Refer to the Specification section, under Settings, for the recommended timing ranges. **Note: a default setting of 1 will be selected if all of the switch segments are set in the DOWN position.**

## Range Multiplier

A three-position slide switch, in conjunction with the "TU" or "TU2" & "TU3" Seconds toggle switches, is used to select the desired multiplication factor. Positioning the switch to its extreme left position, the multiplication factor of 0.01 is selected. With the switch positioned to its mid position, the 0.1 multiplication factor is selected. Finally, the multiplication factor of 1.0 is selected when the switch is in its extreme right position.

## DISPLAYS

### Trip Targets

The trip indicators are electro-mechanical devices and depending on the relay model they are labeled "TA & TB", "T1 & T2" or "T1, T2 & T3". They will operate when the current flowing through their coils is over 150ma. When activated, they will indicate a red block through windows located on the relay's nameplate. The targets are reset by pushing up on the reset rod, which is located on the bottom left hand corner of the front cover.

Table I is a list of the relay models that shows which are equipped with targets and identifies the targets that are provided in those models.

## FUNCTIONAL DESCRIPTION

The SAM relay provides the following basic functions: regulation, timing, output and display. A generic block diagram for the SAM relays is found in Figure 8 and the internal-connection diagrams for each of the models can be found in Figures 9 thru 15.

### Regulation

The input power is regulated by a series-pass Darlington transistor pair that provides the 6 and 12VDC supplies that are required by the various circuits on the timer board.

### Timing

The timing circuits are driven by an oscillator circuit that is tuned to 2kHz. The oscillator circuit clocks binary counters whose outputs become the clock signals for BCD counters. At the end of the desired timing interval, the BCD counters provide the input signal for the output driver circuits through the JK Flip-Flop and Multivibrator circuits.

### Output

Each driver circuit is capable of energizing one output relay. The coil of the output relay is connected in series with the power source and the collector of the drive transistor. The output relay contacts consist of normally open (NO) contacts, and in some models normally closed (NC) contacts. These contacts will change state when the output relay is energized.

The operating time of the output relay, which must be considered when selecting the desired setting of the SAM relay, will vary depending on the voltage that is applied to the relay. Figure 39 shows typical operating time of the output relay with respect to the applied voltage.

### Display

Some of the SAM models provide targets that are connected in series with the normally open contacts of the output relay. The targets will be energized when trip current flows through their coils.

## CONSTRUCTION

The components of the relay are mounted on a cradle assembly that can easily be removed from the relay case, refer to Figures 32 thru 35. The cradle is locked in the case by latches at the top and bottom. The electrical connections between the case blocks and the cradle blocks are completed through removable connection plug(s), as shown in Figure 27, to permit testing the relay in its case. The cover is attached to the front of the case and includes two interlocking arms that prevent the cover from being replaced until the connection plug(s) has been inserted.

The case is suitable for semi-flush mounting on panels. Hardware is available for all panel thicknesses up to two inches. A panel thickness of 1/8 inch will be assumed unless otherwise specified on the order. Outline and panel drilling dimensions for the SAM201 through SAM206 are shown in Figure 16 and for the SAM207 they are shown in Figure 17.

The printed-circuit board(s) are mounted behind the nameplate and can be accessed by removing the four screws securing the nameplate. The boards are mounted horizontally in guides. Each board is labeled to correspond to a given location. Use GE part number 0286A2847P1 card puller or other suitable means to remove the circuit boards. If you do not have a card puller, be careful not to damage or bend any components when removing the boards. A card puller can be obtained by contacting the factory.

The output relays are mounted in sockets on a board fixed to the back of the cradle. If a relay requires replacement, unclip the retaining wire and pull the relay out of the socket.

The target assembly, when provided, is mounted on the bottom plate of the relay cradle.

## RECEIVING, HANDLING and STORAGE

These relays, when not included as part of a control panel, will be shipped in cartons designed to protect them against damage. Immediately upon receipt of a relay examine it for any damage sustained in transit. If damage resulting from handling is evident, file a damage claim at once with the transportation company and promptly notify the nearest General Electric Sales Office.

If the relays are not to be installed immediately, they should be stored in their original cartons in a place that is free from moisture, dust and metallic chips.

## ACCEPTANCE TESTS

### General

The relay should be examined and tested upon delivery to make sure that no damage has been sustained in shipment and that the relay is functioning correctly.

### Visual

Remove the relay from its case and check for signs of physical damage such as broken or cracked parts.

**CAUTION**

Every circuit in the drawout case has an auxiliary brush. It is especially important on circuits with shorting bars that the auxiliary brush be bent high enough to engage the connecting plug or test plug before the main brushes do. This will prevent the secondary circuits from being open-circuited during insertion of the connection plug.

A drawout case relay may be tested without removing it from the panel, by using a 12XLA13A test plug. This plug makes connection to the relay only and does not disturb any shorting bars in the case. The 12XLA12A test plug may also be used. Although this plug allows greater flexibility, it requires shorting jumpers since connections are made to both the relay and the external circuits.

**Test Equipment**

1. DC voltage source rated at 48V with less than 5% ripple
2. Universal Counter with two independent channels
3. Limiting resistors for timing and target tests, 300 $\Omega$ /10W
4. SPST switch, for applying and removing power to the relay
5. Snubber circuit to minimize noise due to the closure of the DC source switch. Resistor, 220 $\Omega$ /2W and a capacitor, 3.3 $\mu$ f/450VDC. **Note: Observe the polarity markings, if an electrolytic capacitor is used in the test circuit.**

**General Testing Considerations****CAUTION**

In the event that the relay is tested with high voltage, 280VDC, and in a temperature environment of greater than 40° C, care must be taken so that the relay is not left energized for a period exceeding five times its maximum time setting. Failure to observe this caution will damage the relay.

The relay can be tested by using one or two simple tests. These tests are the Timing test, and for those models that are equipped with targets, the Target test. The timing test procedures are similar for all relay models; the target test procedures are similar for all relay models that include targets.

All tests should be made with the relay in its case and in a reasonably level position.

**Tests**

For the following tests refer to Figures 18 thru 26 for test connections, and to Figure 29, 30 and 31 for front views of several relay models.

### Timing Test

1. Connect the SAM relay to be tested as per the appropriate timing test connections diagram, Figures 18 thru 22.
2. Set the "TU" or "TU2" & "TU3" SECONDS switch segment labeled "2" to the UP position. All other switch segments must be set to the DOWN position.
3. Set the RANGE MULTIPLIER switch to "1.0".
4. Set the DC Power supply to 48 volts.
5. Apply the 48VDC to the relay by closing switch "S1". Note: in order for the timing circuits to function correctly, the DC voltage must be suddenly applied to the relay.
6. Check that the output relay has picked up between 1.94 and 2.06 seconds, as indicated by the universal counter(s).

### Target Test

1. Connect the SAM relay to be tested as per the appropriate target test connections diagram, Figures 23 thru 26.
2. Set all of the "TU" or "TU2" & "TU3" SECONDS switch segments to the DOWN position.
3. Set the RANGE MULTIPLIER switch to "1.0".
4. Set the DC Power supply to 48 volts.
5. Apply the 48VDC to the relay by closing switch "S1".
6. Check that the correct target has picked up.

### End Of Acceptance Testing

## INSTALLATION PROCEDURE

The relay should be installed in a clean, dry location, free from dust and excessive vibration. It should be mounted on a vertical surface. The outline and panel-drilling dimensions are shown in Figures 16 and 17.

### Surge ground

The case stud should be permanently connected to ground by a conductor not less than AWG No. 12 copper wire or equivalent. This connection is made to ground the relay case and the surge suppression networks in the relay. The surge ground lead should be as short as possible, preferably 10 inches or less, to provide maximum protection from surges. Figures 37 and 38 show the rear view of an S1 and an S2 case, respectively, illustrating the position of the case grounding stud.

## Electrical tests

The test given in the Acceptance Section can be used as a guide in the establishment of your procedure.

## Settings

**Time** Set the timing circuit(s) for the operating time required by the particular application. The setting is equal to the sum of the "TU", "TU2" or "TU3" SECONDS switch segments that are set in the UP position, multiplied by the setting of the Range Multiplier switch.

The recommended timing ranges are listed in the Specification section of this manual, under Settings.

## PERIODIC CHECKS and ROUTINE MAINTENANCE

Considering the vital role of protective relays in the operation of a power system, it is important that a periodic test program be followed. It is recognized that the interval between periodic checks will vary depending upon environment, type of relay, and the users' experience with periodic testing. Until the users have accumulated enough experience to select the test interval best suited to their individual requirements, it is suggested that the points listed under Acceptance Tests be checked at an interval of from one to two years.

The procedure outlined under Acceptance Tests can be followed.

## SERVICING

### CAUTION

**REMOVE ALL power from relay before removing or inserting any of the printed-circuit boards or output relays. Failure to observe this caution may result in damage to and/or misoperation of the relay.**

There are two basic approaches that may be followed in servicing the SAM relay. One approach is field service, where an attempt is made to replace defective components at the relay location. Generally, this will take the most time and require the highest degree of skill and understanding. It can also be expected to result in the longest system-outage time.

The preferred approach is board replacement, where a determination is made as to which printed-circuit board has failed and that board is replaced with a spare board. The system can then be quickly returned to service. Considerable time is saved and there is much less pressure to make a decision about what to do with the defective part. This approach typically yields the shortest down time. It is recommended that a complete set of spare printed-circuit board be kept at the main maintenance center.

For those who wish to repair at the component level, drawings are available from the factory. When requesting drawings, the following information must be supplied to the factory.

The assembly number of the p/c board. This is found on the component side of the printed-circuit board. It is an eight-digit number with a letter inserted between the fourth and fifth digit and suffixed with a group identification, e.g. 0215B5865 G001 or G1.

The revision number. This is also found on the printed-circuit board, e.g. REV.1.

The acceptance tests should be performed after a printed-circuit board has been repaired or replaced.

Whenever the nameplate is removed from the relay, care must be taken when replacing it so that it does not interfere with the mechanical operation of any switches that protrude through the nameplate.

### RENEWAL PARTS

It is recommended that sufficient quantities of renewal parts be carried in stock to enable the prompt replacement of any that are broken or damaged.

When ordering renewal parts address the nearest Sales Office of the General Electric Company. Specify the quantity required, the name of the part wanted, the part number if known, and the complete model number of the relay for which the part is required. The table below lists the part numbers for the most common replacement parts.

It is recommended that renewal parts only be obtained from the General Electric Company. Should a printed-circuit card become inoperative, it is recommended that the card be replaced with a spare.

<u>Model SAM</u>	<u>Function</u>	<u>Part number</u>
201 202 205	Timer Board	0184B8750G-1
203	Timer Board	0184B8750G-5
204	Timer Board	0184B8750G-2
206	Timer Board	0184B8750G-3
207	Timer Board	0184B8750G-4
201	Backplane	0188B9755G-1
202	Backplane	0184B9755G-2
203	Backplane	0184B9755G-3
204	Backplane	0184B9755G-4
205	Backplane	0184B9755G-5
206	Backplane	0184B9755G-6
207	Backplane	0184B9756G-1

<u>Model SAM</u>	<u>Function</u>	<u>Part number</u>
201 202 203 204 205 206 207	Output relay(s)	0246A9826P-5
201 203 205 206	Target(s)	0188B9764G-1
201 202	Lower Cradle Block	0184B8624G-4
203	Lower Cradle Block	0184B8624G-5
204 205	Lower Cradle Block Lower Cradle Block	0184B8624G-6 0184B8624G-7
206	Lower Cradle Block	0184B8624G-8
207 207	Lower Cradle Block Upper Cradle Block	0184B8624G-9 0184B8624G-12
201 202	Lower Case Block	06418058G-646
203 206	Lower Case Block	06418058G-45
204	Lower Case Block	06418058G-144
205	Lower Case Block	06418058G-617
207 207	Lower Case Block Upper Case Block	06418058G-158 06418058G-158
201 203 205 206	Cover	0128B2305G-5
202 204	Cover	0128B2305G-2
207	Cover	006229807G-7

## TROUBLE SHOOTING

### WARNING

**THE POWER SUPPLY IN THIS RELAY IS NOT ISOLATED FROM THE INCOMING POWER. ALL TRANSISTOR HEAT SINKS ARE AT THE INCOMING POTENTIAL. FURTHER, THE COMMON OF THE REGULATED DC IS AT THE SAME POTENTIAL AS THE MOST-NEGATIVE POWER TERMINAL AND SHOULD NOT BE CONNECTED TO GROUND. MAKE SURE THAT TEST INSTRUMENTS CONNECTED TO MONITOR THE SIGNALS WITHIN THE RELAY ARE SUITABLY ISOLATED FROM GROUND AND OBSERVE PROPER TECHNIQUES TO AVOID A SHOCK HAZARD.**

The following equipment will be required for trouble shooting the relay. A 48VDC power supply, capable of supplying at least 60ma of current, to energize the relay. A counter with two independent channels that can be triggered on positive edges. A frequency counter, to measure the clock frequency. A storage scope to measure the various timing signals. A multi meter, and finally a card extender board, GE part number 0215B8031G1, which is required to perform the tests indicated in the trouble-shooting guide.

### CAUTION

**REMOVE ALL power from relay before removing or inserting any of the printed-circuit boards or output relays. Failure to observe this caution may result in damage to and/or misoperation of the relay.**

The trouble-shooting diagram, Figure 28, will be extremely useful in identifying defective circuits in the relay. In addition to the trouble shooting diagram, a functional description of the timer board and a list of possible problems / solutions have been provided in this section.

Additionally, several views of the relay have been provided, Figures 29 thru 38. These figures will assist in identifying, as well as locating, components in the relay.

The trouble-shooting diagram, Figure 28, illustrate voltages and waveforms to be found at selected points in the relay. The points are the pin numbers of the various components found in the relay and timer board, as well as the connector pin numbers on the extender board. The failure of the signal to meet the values and levels shown on the diagram indicates a failure in that portion of the circuit.

All signals should be measured with high-input-impedance instruments to avoid loading the circuits. **Remember the regulated DC is not isolated.**

A logic low is a signal with an amplitude of between zero and 20% of the regulated DC voltage; nominally this is 0 to 2.4 volts for the 12 volt supply and 0 to 1.2 volts for the 6 volt supply. A logic high is defined as a signal whose amplitude is between 80% and 100% of the regulated DC voltage; nominally this is 9.6 to 12 volts for the 12 volt supply and 4.8 to 6.0 volts for the 6 volt supply.

Commence the trouble-shooting procedure by setting all of the "TU" or "TU2" & "TU3" SECONDS switch segments to the UP position. Set the RANGE MULTIPLIER switch to the 0.01 setting. Apply 48VDC to the appropriate input power terminals of the relay (refer to Figures 9 thru 15). Begin to check for the voltages and waveforms indicated in the trouble-shooting diagram.

## TIMER BOARD FUNCTIONAL DESCRIPTION

### Regulation

The input power is regulated by a series-pass Darlington transistor pair, Q5 and Q6. The base of Q5 is referenced to 13.2 DC by Z1 (12 VDC) and D6 & D7. Current limit, which is set for 24mA, is provided by R39 and Q7. When the voltage drop across R39, a 24.9 $\Omega$  resistor, exceeds 0.6VDC, Q7 turns on and takes base current from Q5. This action turns off Q5, thus causing the output to collapse. Q8, R40 and Z2 provide 6 DC for use by the driver circuits.

### Timing

The timing circuit(s), Input 1 and/or Input 2, are driven by an oscillator circuit. The oscillator circuit, which consists of three U4 inverters, three resistors, R5, R6 & R46 and a capacitor, C8, is tuned to 2kHz. The oscillator clocks the binary counter, U3. The output of U3 becomes the clock signal for U6, which is another binary counter. Through different segments of the range multiplier switch, SW3, the output of U3 as well as the output of U6 become the clock signal for BCD counters U1 and/or U8.

Setting SW3 to the extreme left position, the 0.01 setting, will program U3 to divide by 20 and its output is connected to BCD counters U1 and or U8. With SW3 set to the mid position, the 0.1 setting, U3 is programmed to divide by 200 and its output is likewise connected to U1 and or U8. Placing SW3 to the extreme right position, the 1.0 setting, will program U3 to divide by 200 and this output clocks U6, which is programmed to divide by 10. The output of U6 then becomes the clock signal for U1 and/or U8.

Setting the timing switches, SW1 & SW2 and SW4 & SW5, ON, to the UP position, will program the BCD counters to the desired timing interval. The timing interval is equal to the sum of the switches in the UP position. If all the programming switches are set OFF, to the DOWN position, the circuitry will give the BCD counters a default setting of 1. The time interval, due to the default setting, will be equal to the setting of switch SW3, which can be 10, 100 or 1000 msec.

The output of the BCD counters, U1 and or U8, goes low at the end of the desired timing interval. The transition from high to low is inverted to create positive edges that become the triggering signals for flip flop U10. The BCD counters will continue to count at the maximum possible setting of 256 counts for as long as the power is applied to the circuit. However, the flip flop, U10, will change state on the first positive-going edge and ignore all subsequent positive edges. The outputs of U10 are connected to pins 47 and 48, to monostable multivibrator, U7, as well as to the driver circuit(s) of the output relay(s). The multivibrator, U7, provides output pulses of approximately 20 msec. These pulses are also applied to the driver circuit(s) of the output relay(s).

### Output

Each driver circuit consists of non-inverting buffers, resistors, diodes and a transistor. Buffer(s), U2, are connected to the 12 DC supply rail and provide the 20 msec. pulse signal(s) from the timing circuit(s) to the driver circuit(s). The continuous signals from the timing circuits to the driver circuit(s) are provided by buffer(s), U5, which are connected to the 6 DC supply rail. Each driver circuit can be driven by either timing circuit, Input 1 or Input 2, but not both. The selection is made by choosing the proper resistor combination from the following groups, R19 thru R22, R25 thru R28 or R31 thru R34.

Each driver circuit is capable of energizing one output relay. The coil of the output relay is connected in series with the power source and the collector of the drive transistor. When active, the transistor, which acts as a variable-series resistor to the relay, is biased in the linear region. The voltage across the emitter resistor remains constant, regardless of the applied battery voltage. Since the voltage across the resistor is constant, the current flowing through it is also constant. Thus the collector current is constant, regardless of the battery voltage and therefore, the relay is controlled by the current and not the voltage applied.

### PROBLEMS and SOLUTIONS

<u>Symptoms</u>	<u>Solutions</u>
No clock signal, monitored after R43.	Replace U4.
Output relay(s) picks up for 20ms then drops out.	Check 6V supply. If incorrect, replace Z2, Q8 and/or U5.
Timer board draws more than 60ma.	Check Q7 and R39. Check that all output relay coils measure $1100\Omega \pm 140\Omega$ . Check for defective chips by monitoring their temperature.
SAM Relay times out before or after expected setting (including specified timing error).	Make sure that the external power supply rises up to voltage in less than 3ms. Check the clock frequency, after R43.
SAM Relay was left energized continuously at elevated temperatures.	Replace R37. Replace any output relay whose coil resistance is much less than specified above. Replace driver transistor and resistor associated with the defective relay. e.g., Q3 & R24 if K1 is defective; Q4 & R30 if K2 is defective and Q9 & R36 if K3 is defective.

Since the last edition, changes have been made in **RATINGS, Burden, Contact ratings, and in Figure 41.**

## List of Figures

Figure 1	External connection diagram for the SAM201	(0286A1831)	18
Figure 2	External connection diagram for the SAM202	(0286A1832)	19
Figure 3	External connection diagram for the SAM203	(0286A1833)	20
Figure 4	External connection diagram for the SAM204	(0286A1834)	21
Figure 5	External connection diagram for the SAM205	(0286A1835)	22
Figure 6	External connection diagram for the SAM206	(0286A1836)	23
Figure 7	External connection diagram for the SAM207	(0286A1837)	24
Figure 8	Functional Block diagram for the SAM RELAYS	(0286A1838)	25
Figure 9	Internal connections diagram for the SAM201	(0184B8751)	26
Figure 10	Internal connections diagram for the SAM202	(0184B8752)	27
Figure 11	Internal connections diagram for the SAM203	(0184B8753)	28
Figure 12	Internal connections diagram for the SAM204	(0184B8754)	29
Figure 13	Internal connections diagram for the SAM205	(0184B8755)	30
Figure 14	Internal connections diagram for the SAM206	(0184B8756)	31
Figure 15	Internal connections diagram for the SAM207	(0184B8757)	32
Figure 16	Outline and mounting dimensions for the SAM201-206	(0285A5392)	33
Figure 17	Outline and mounting dimensions for the SAM207	(0285A5393)	34
Figure 18	Timing Test connections for SAM201, 202 & 205	(0286A1862)	35
Figure 19	Timing Test connections for SAM203	(0286A1863)	36
Figure 20	Timing Test connections for SAM204	(0286A1864)	37
Figure 21	Timing Test connections for SAM206	(0286A1865)	38
Figure 22	Timing Test connections for SAM207	(0286A1866)	39
Figure 23	Target Test connections for SAM201	(0286A1867)	40
Figure 24	Target Test connections for SAM203	(0286A1868)	41
Figure 25	Target Test connections for SAM205	(0286A1869)	42
Figure 26	Target Test connections for SAM206	(0286A1870)	43
Figure 27	Drawout case contact assembly	(8025039)	44
Figure 28	Trouble shooting diagram for the SAM201 - SAM207	(0153D7769)	45
Figure 29	Front View of the SAM203 with the cover removed	(8043819)	46
Figure 30	Front view of the SAM206 with the cover removed	(8043820)	47
Figure 31	Front view of the SAM207 with the cover removed	(8043821)	48
Figure 32	Typical "S1" Cradle Assembly removed from Case	(8043822)	49
Figure 33	Typical "S1" Cradle Assembly with nameplate removed	(8043823)	50
Figure 34	Typical "S1" Cradle Assembly with nameplate and circuit boards removed	(8043824)	51
Figure 35	Rear view of a typical "S1" Cradle Assembly	(8043825)	52
Figure 36	View of a typical Timer P/C Board Assembly	(8043826)	53
Figure 37	Rear view of a Relay Case (S1) with surge ground stud location	(8043827)	54
Figure 38	Rear view of a Relay Case (S2) with surge ground stud location	(8043828)	55
Figure 39	Output Relay operating time	(0286A1873)	56
Figure 40	SAM202 used in breaker-failure scheme	(0153D7809)	57
Figure 41	SAM202 used in 2 zone step distance scheme	(0153D7810)	58
Figure 42	SAM204 used in 3 zone step distance scheme	(0153D7811)	59
Figure 43	SAM206 used in 3 zone step distance scheme	(0153D7812)	60

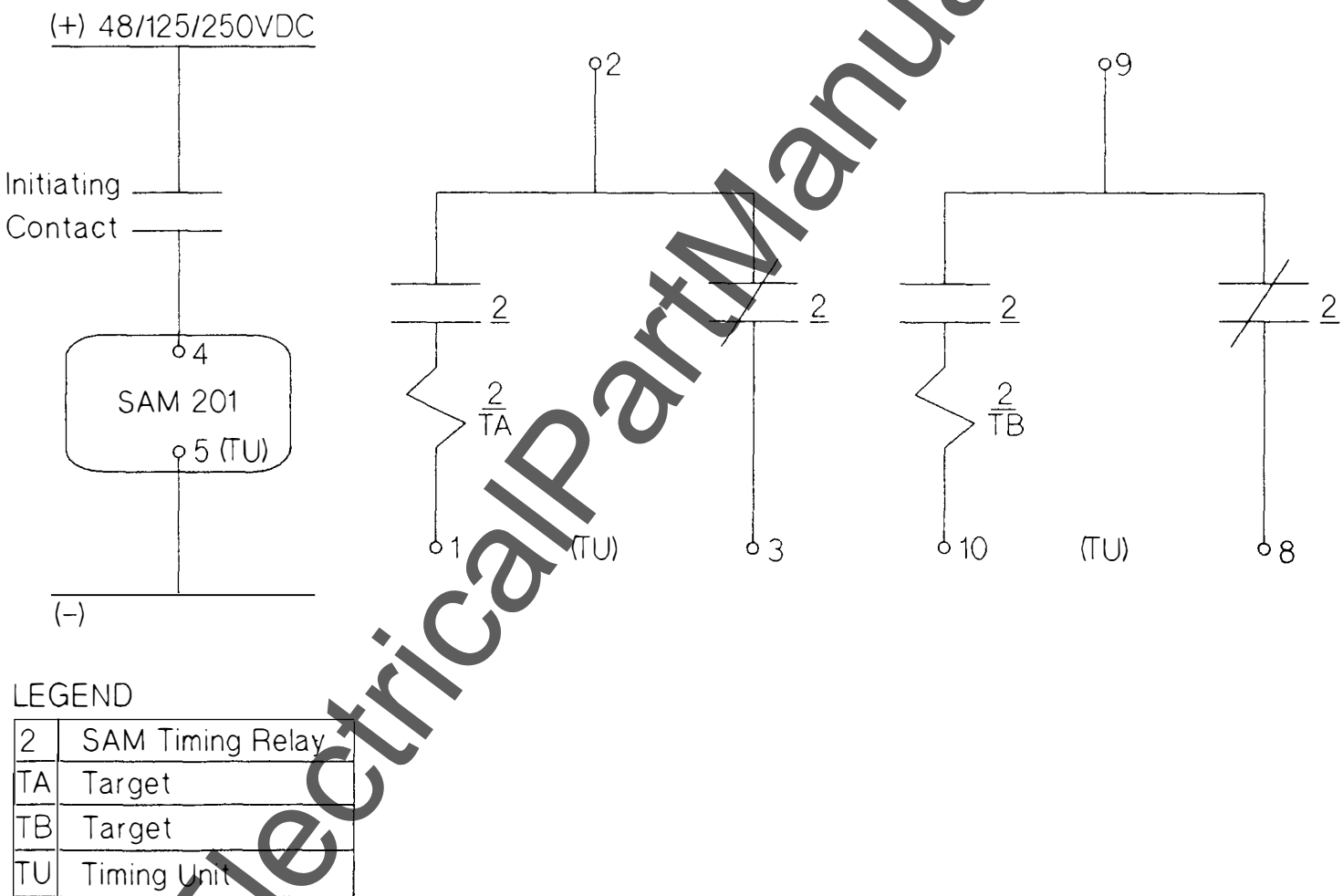

Figure 1 (0286A1831) External-Connection Diagram for the SAM201

(+) 48V/25/250VDC



LEGEND

2	SAM Timing Relay
TU	Timing Unit

Figure 2 (0286A1832) External-Connection Diagram for the SAM202

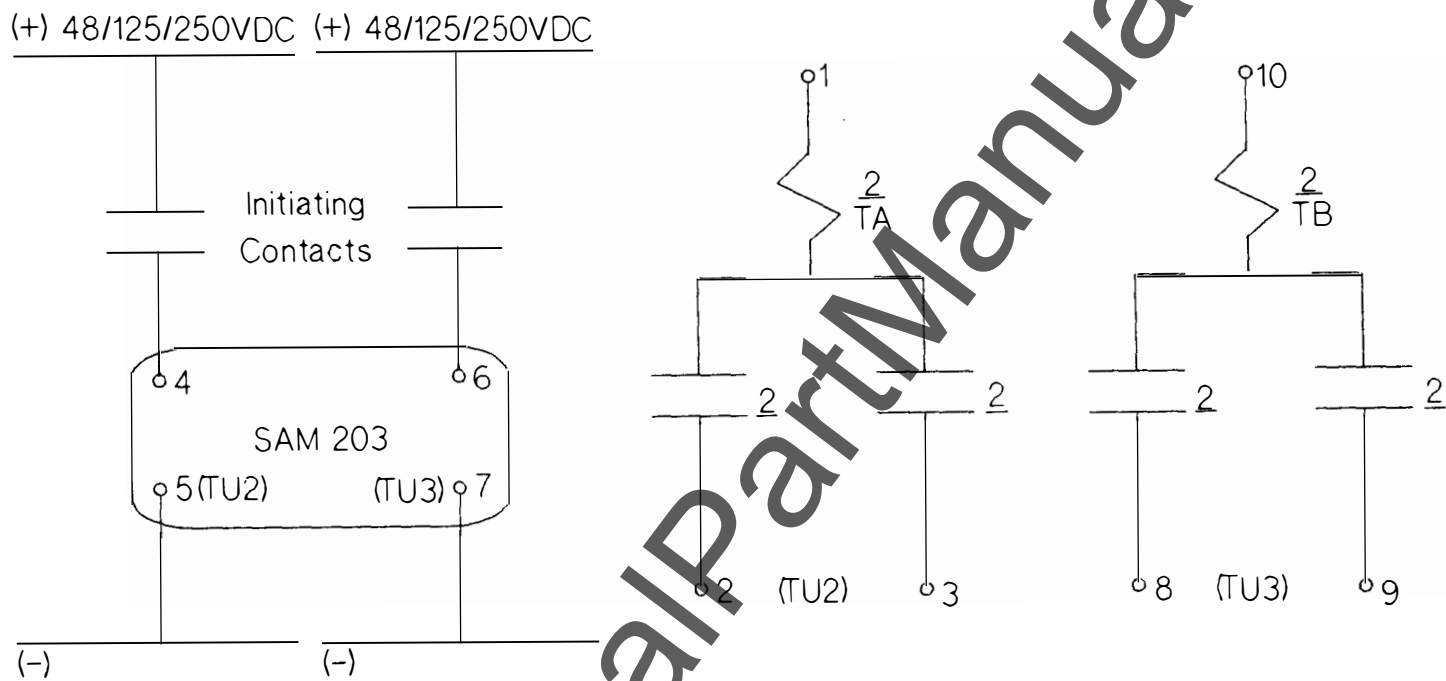

LEGEND

2	SAM Timing Relay
TA	Target
TB	Target
TU2	Timing Unit 2
TU3	Timing Unit 3

Figure 3 (0286A1833) External-Connection Diagram for the SAM203

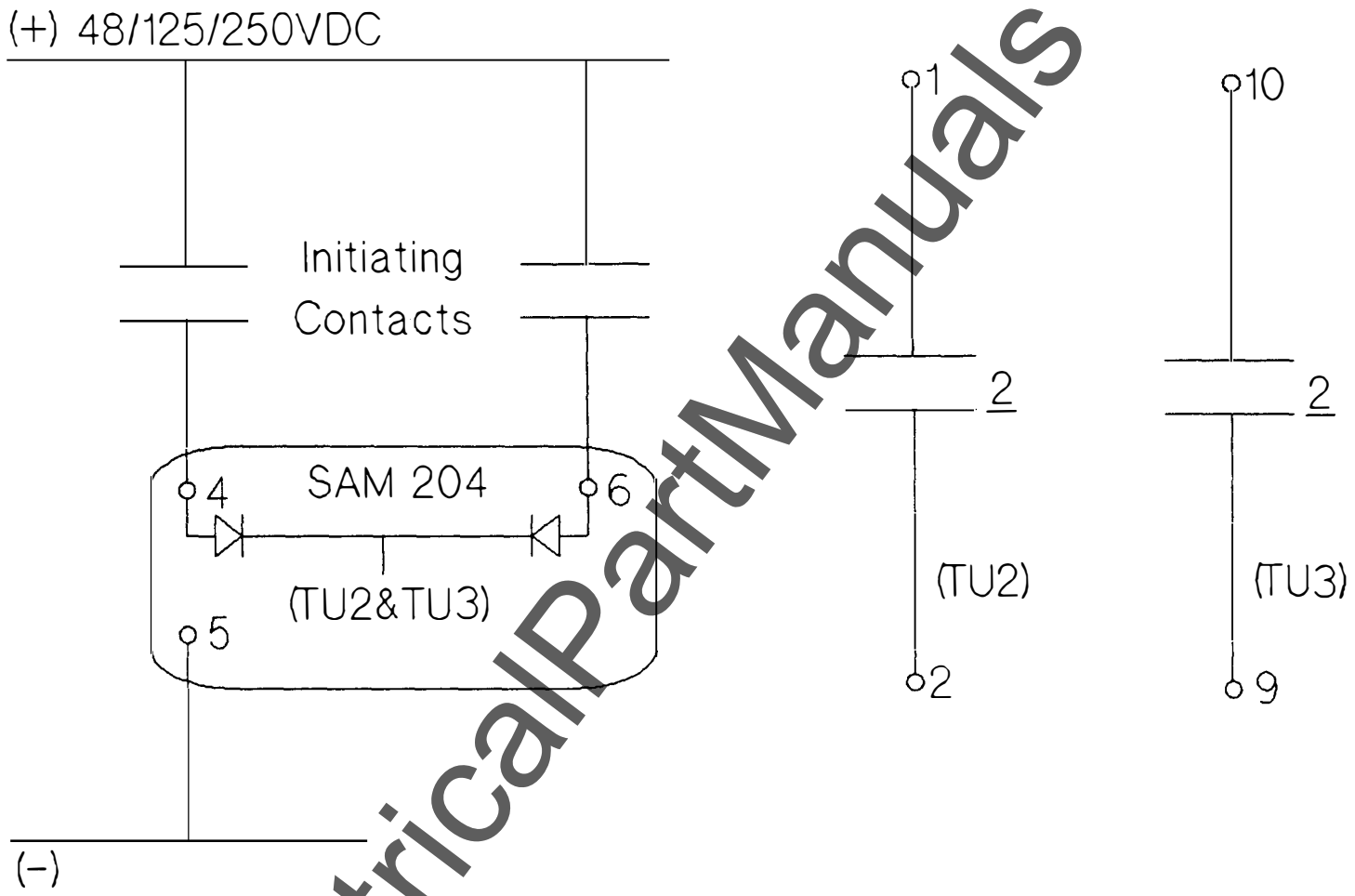

LEGEND

2	SAM Timing Relay
TU2	Timing Unit 2
TU3	Timing Unit 3

Figure 4 (0286A1834 [1]) External-Connection Diagram for the SAM204

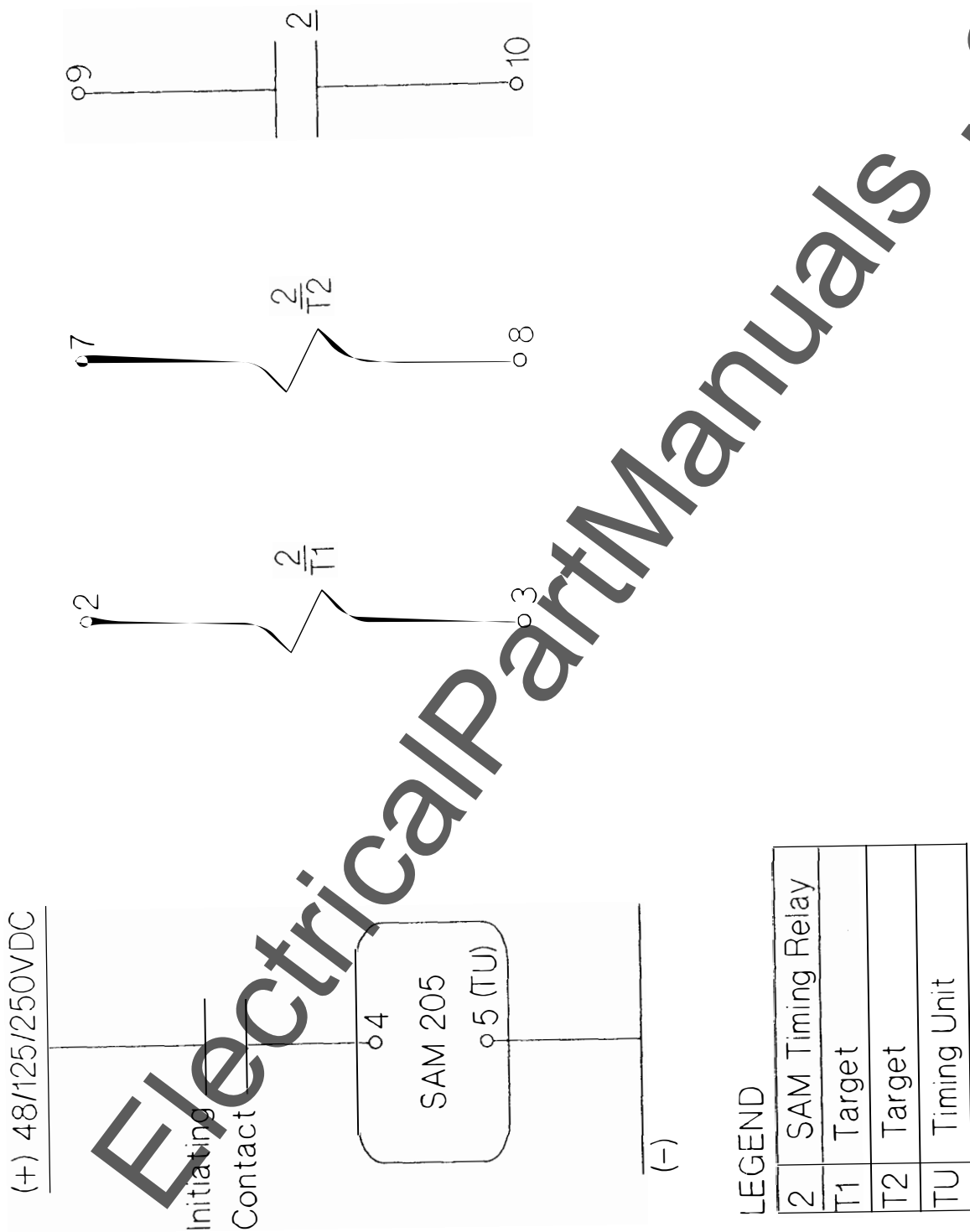

LEGEND

2	SAM Timing Relay
T1	Target
T2	Target
TU	Timing Unit

Figure 5 (0286A1835) External-Connection Diagram for the SAM205

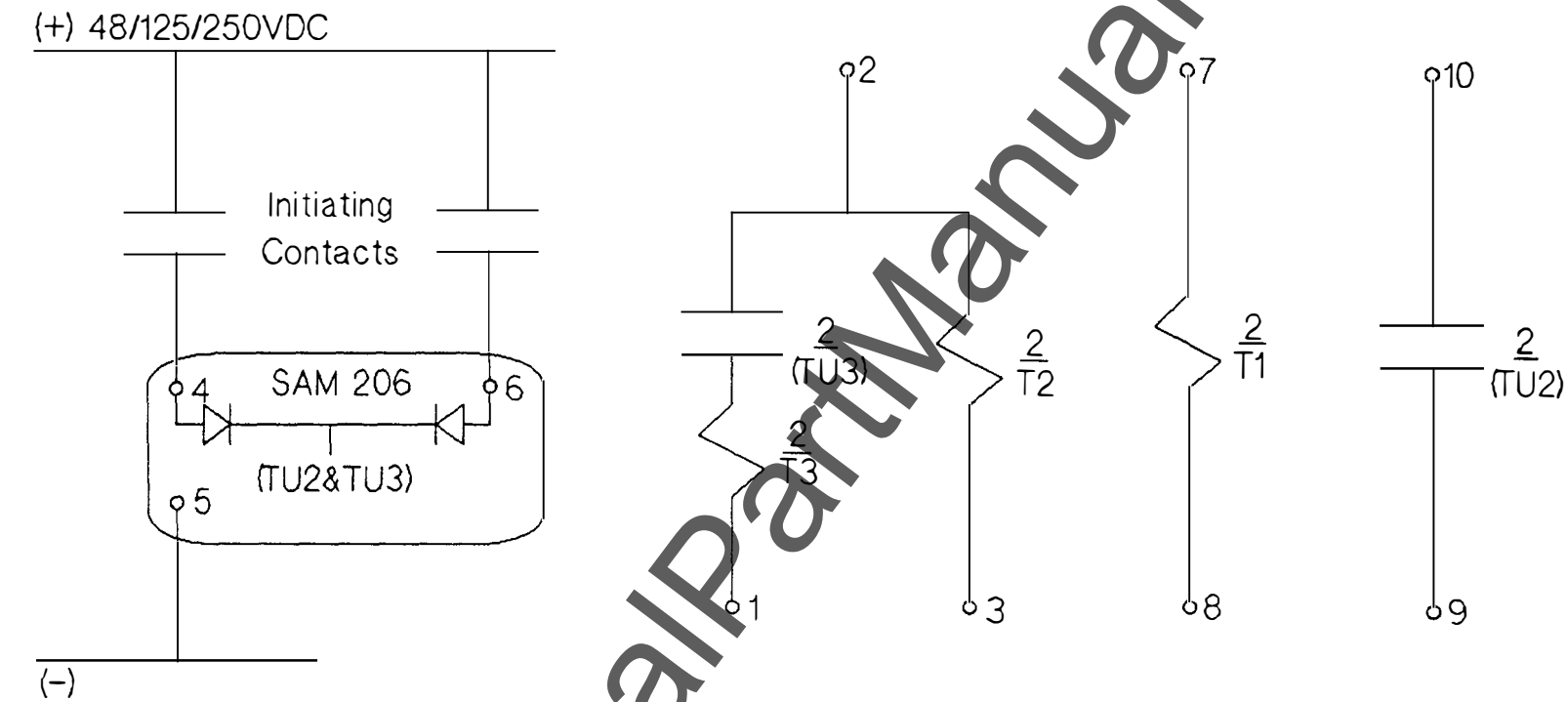

LEGEND

2	SAM Timing Relay
TU2	Timing Unit 2
TU3	Timing Unit 3
T1	Target
T2	Target
T3	Target

Figure 6 (0286A1836 [1]) External-Connection Diagram for the SAM206

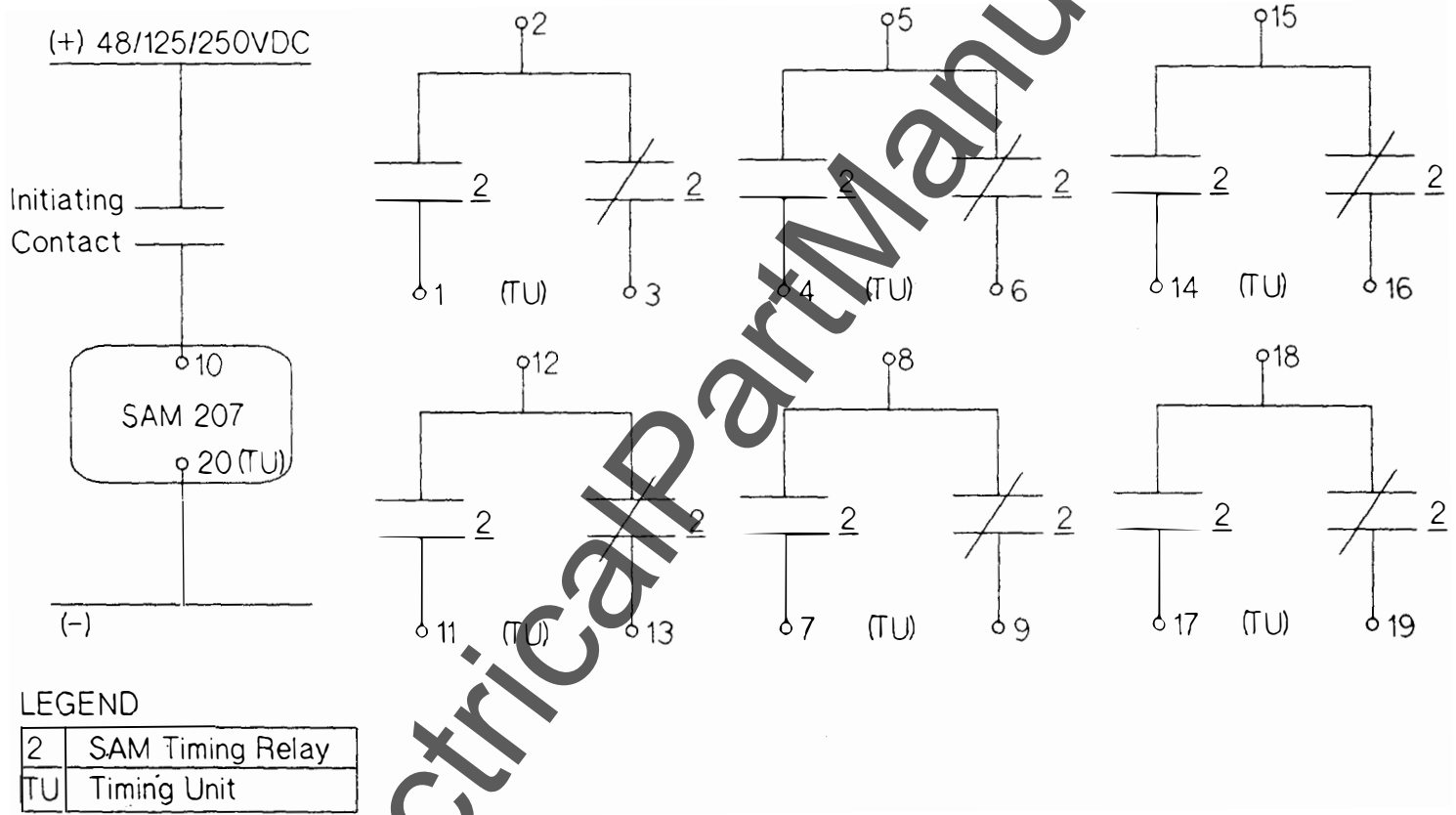

Figure 7 (0286A1837) External-Connection Diagram for the SAM207

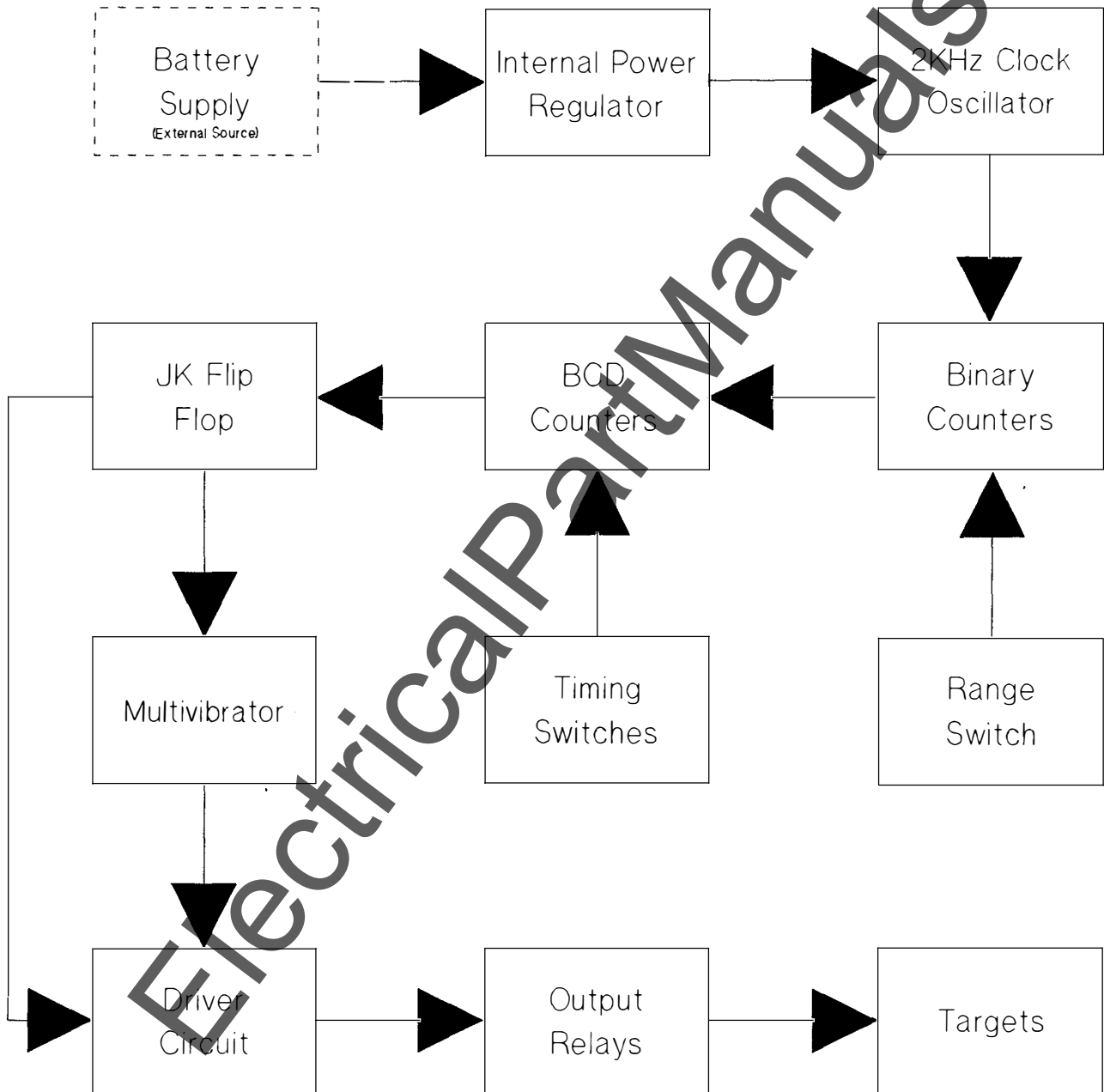

Figure 8 (0286A1838) Functional Block Diagram for the SAM Relays

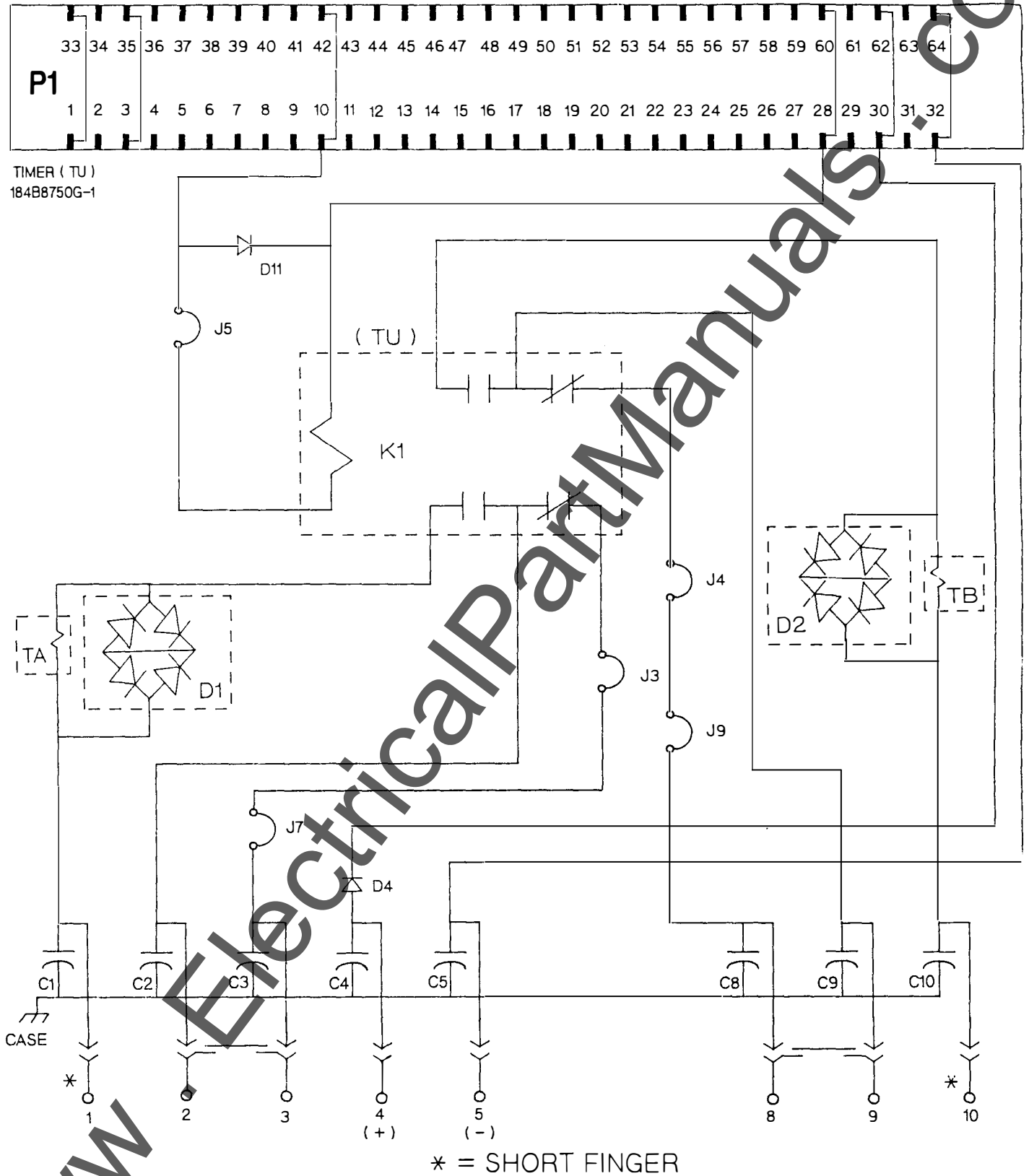

Figure 9 (0184B8751 [1]) Internal-Connections Diagram for the SAM201

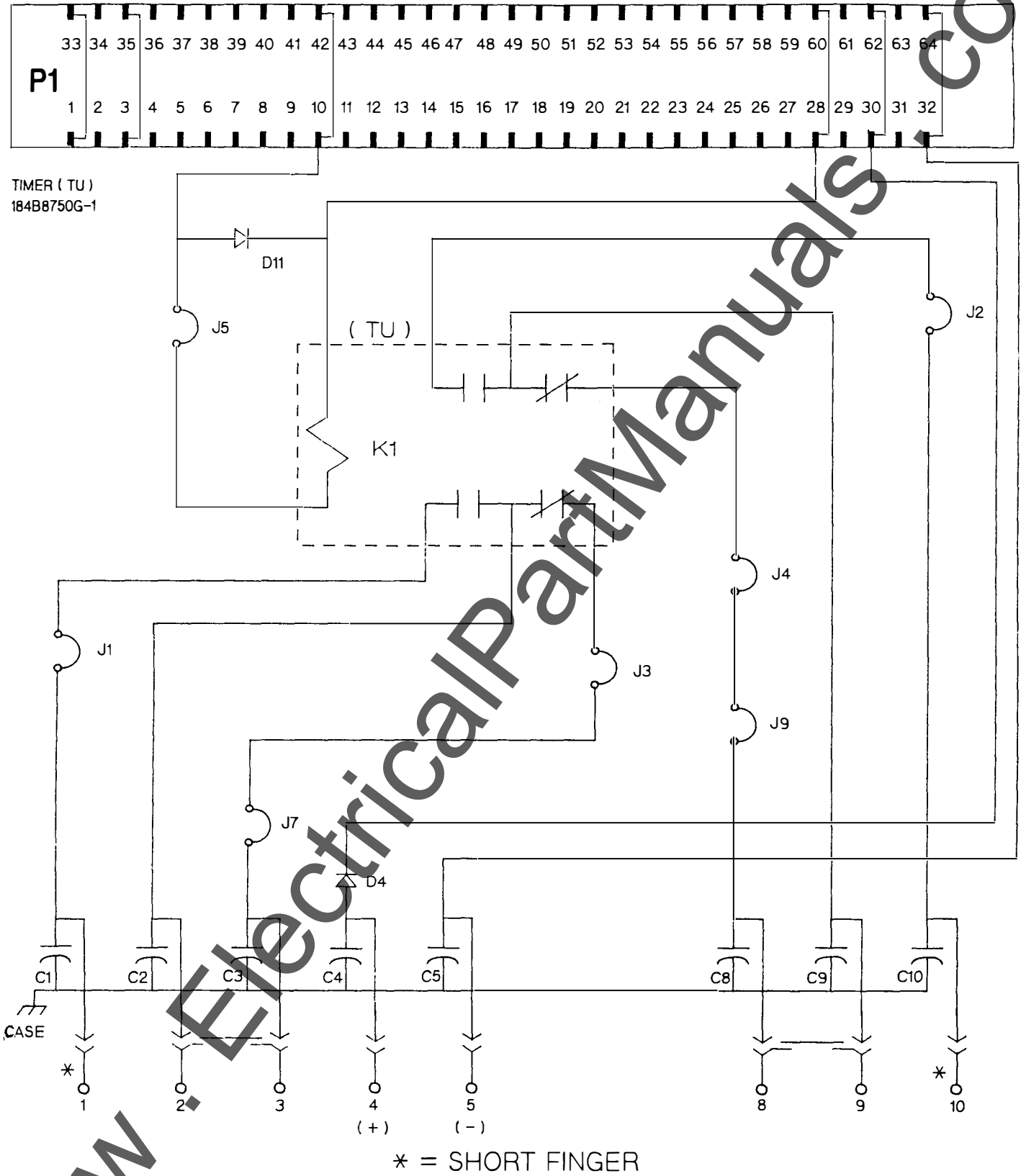

Figure 10 (0184B8752 [1]) Internal-Connections Diagram for the SAM202

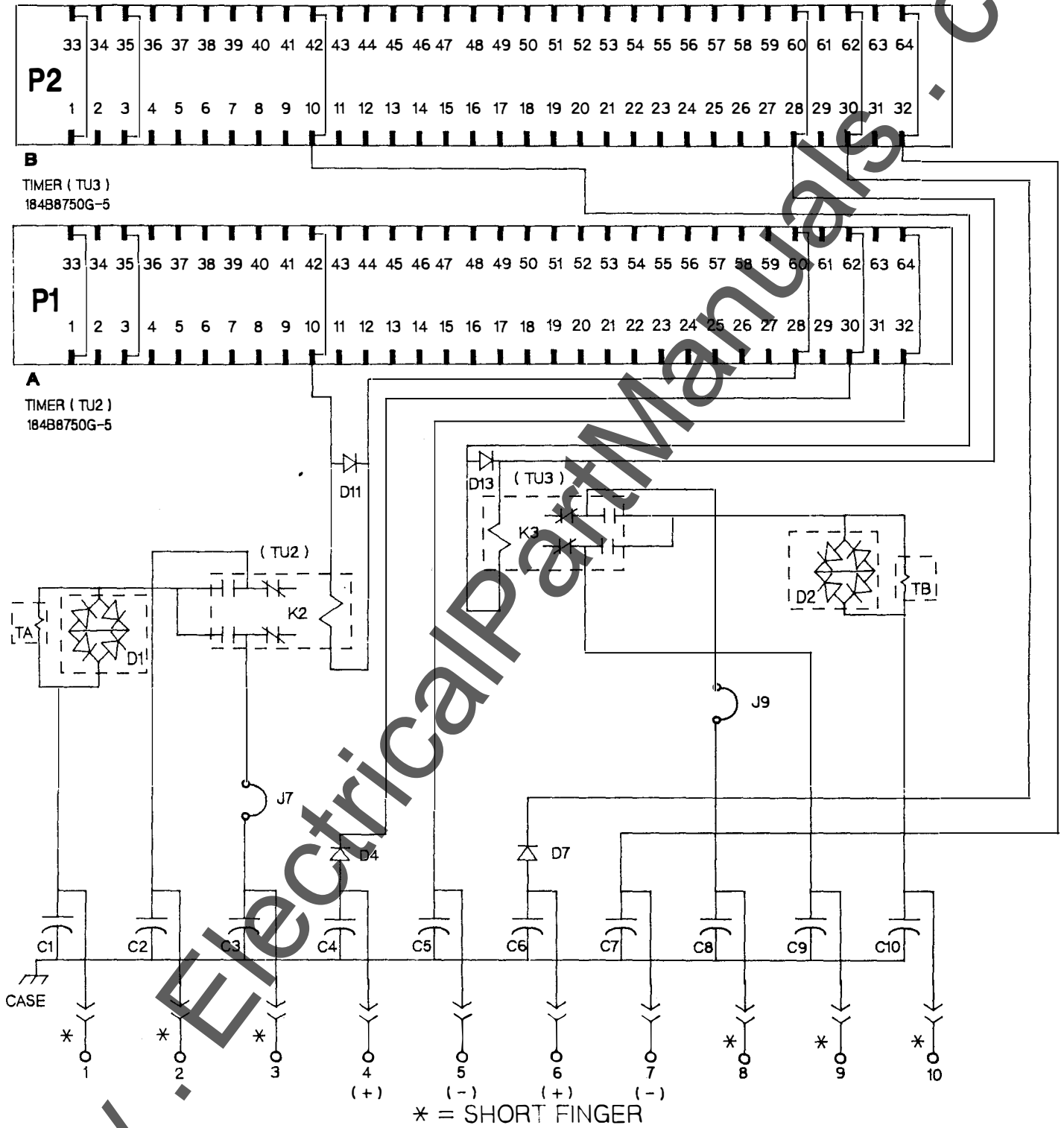

Figure 11 (0184B8753 [1]) Internal-Connections Diagram for the SAM203

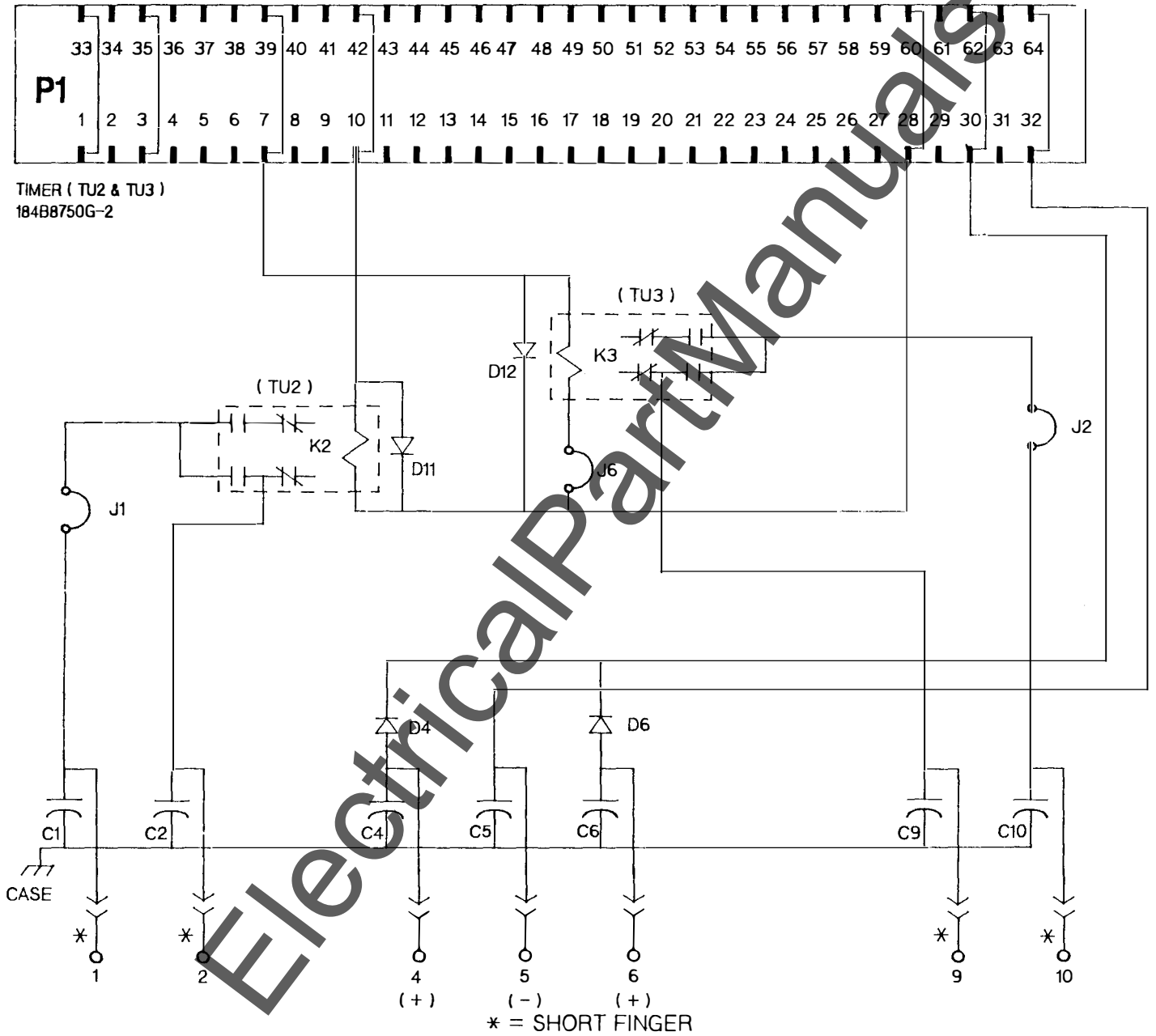

Figure 12 (0184B8754 [1]) Internal-Connections Diagram for the SAM204



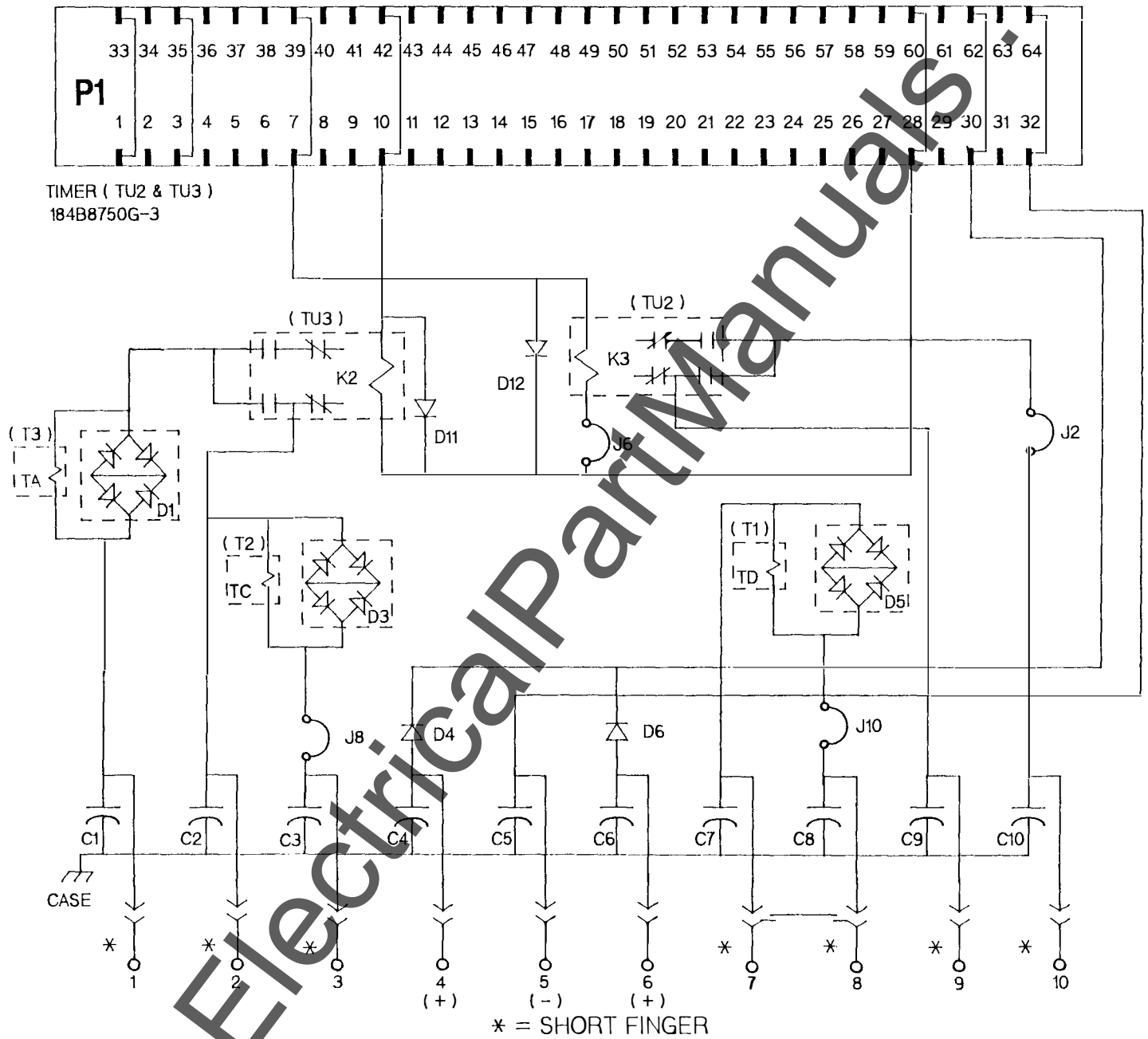

Figure 14 (0184B8756 [1]) Internal-Connections Diagram for the SAM206

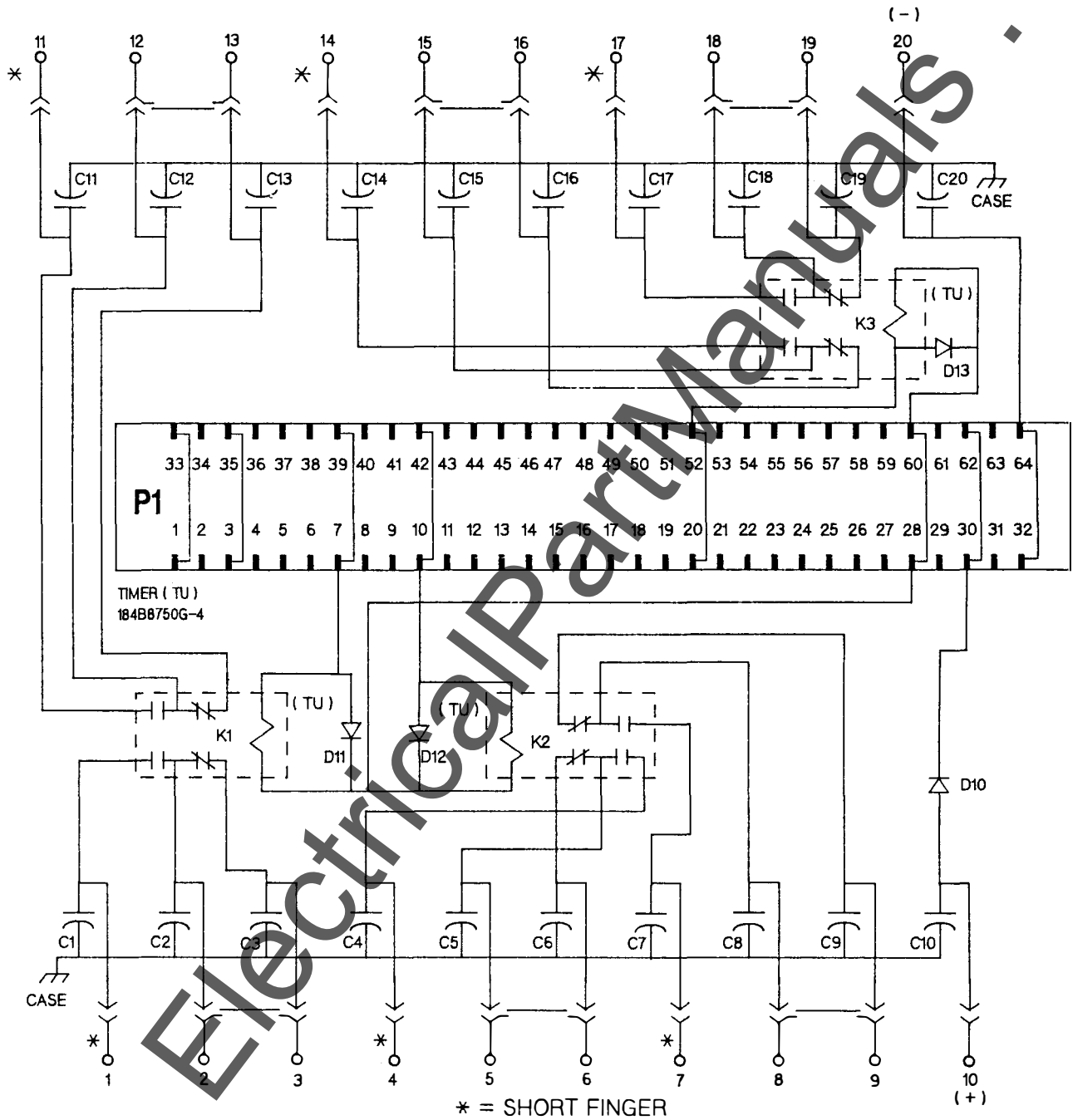

Figure 15 (0184B8757 [2]) Internal-Connections Diagram for the SAM207

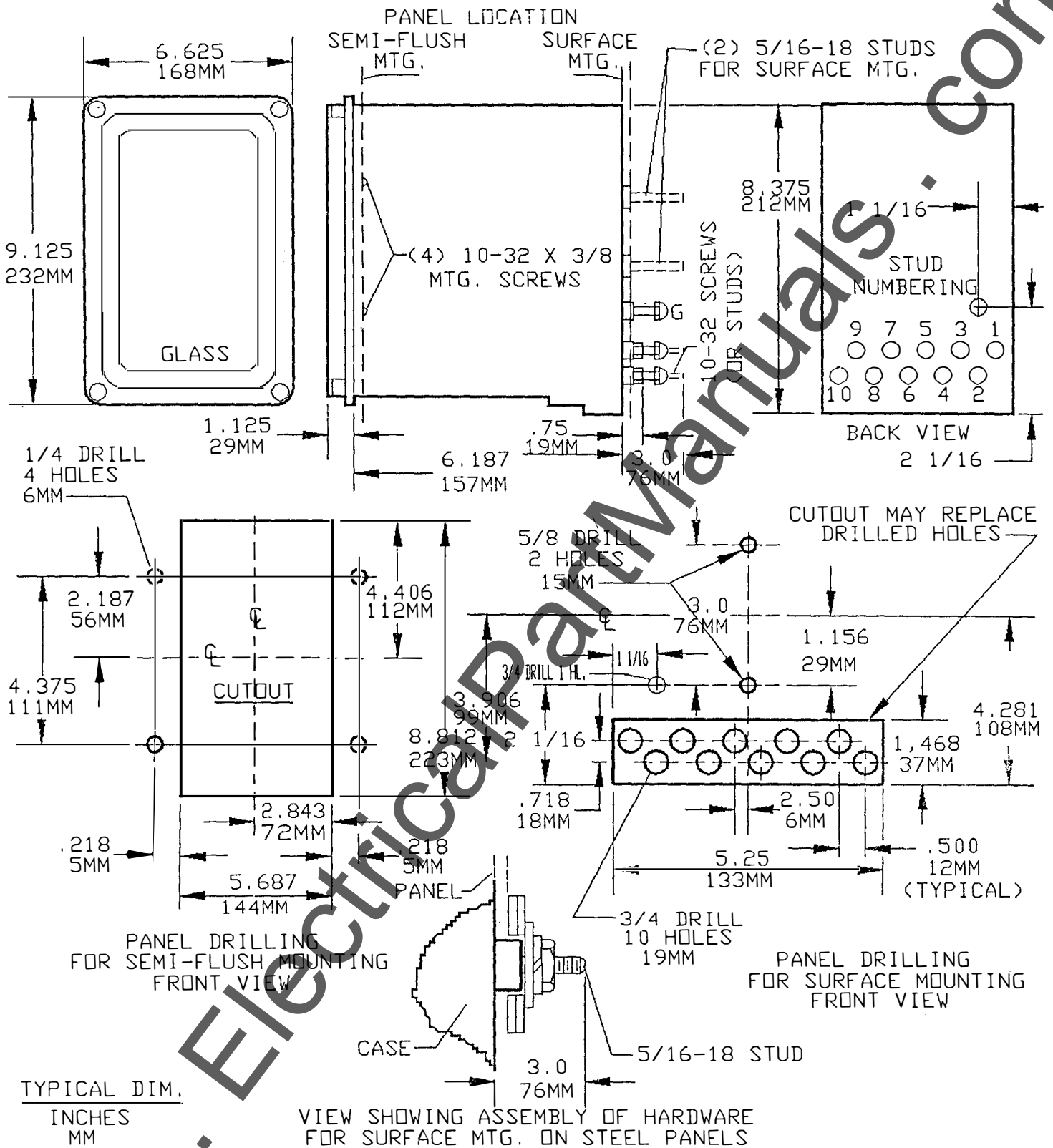

Figure 16 (0285A5392) Outline and Mounting Dimensions for the SAM201-206



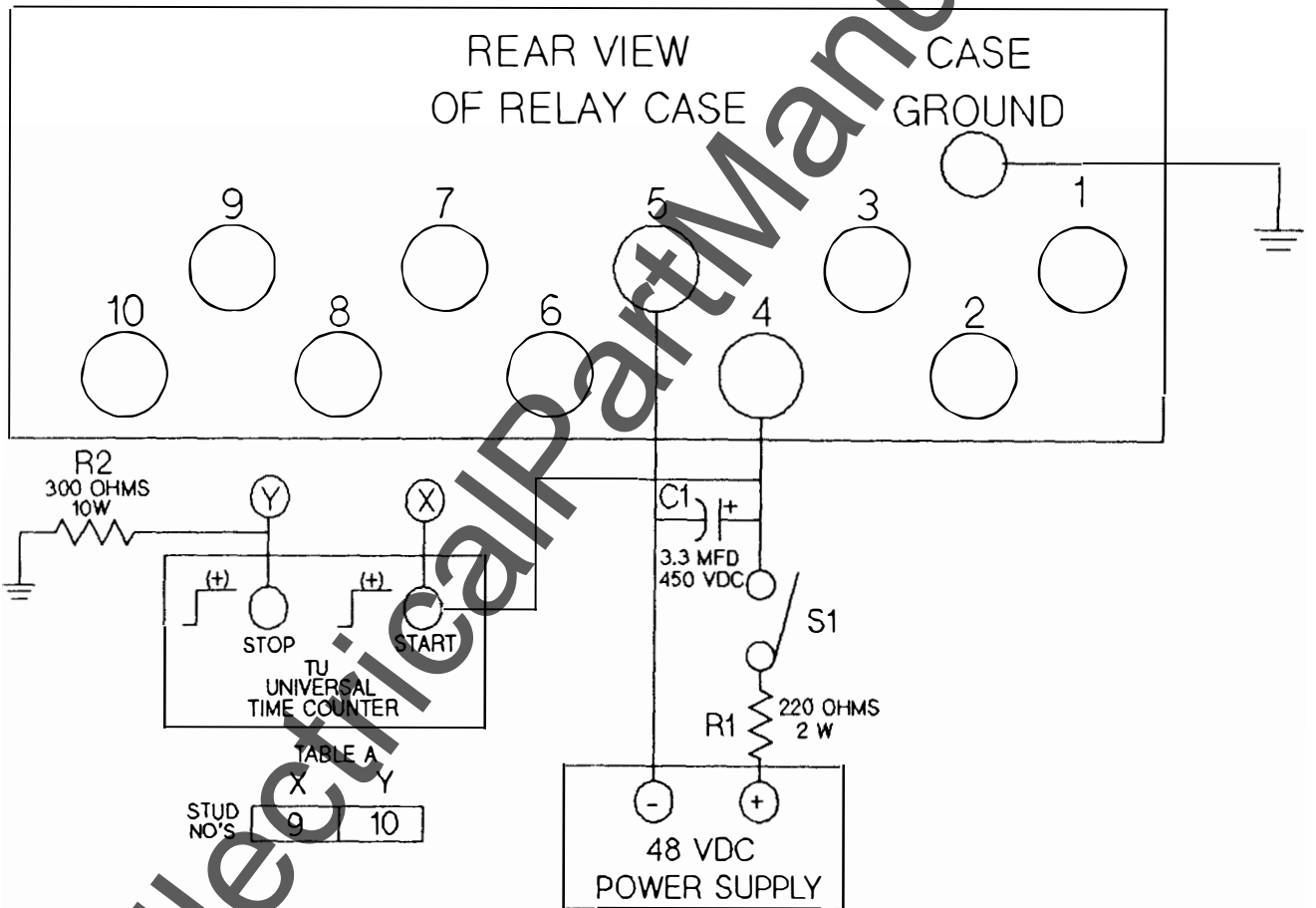

Figure 18 (0286A1862) Timing Test Connections for SAM201, 202 & 205

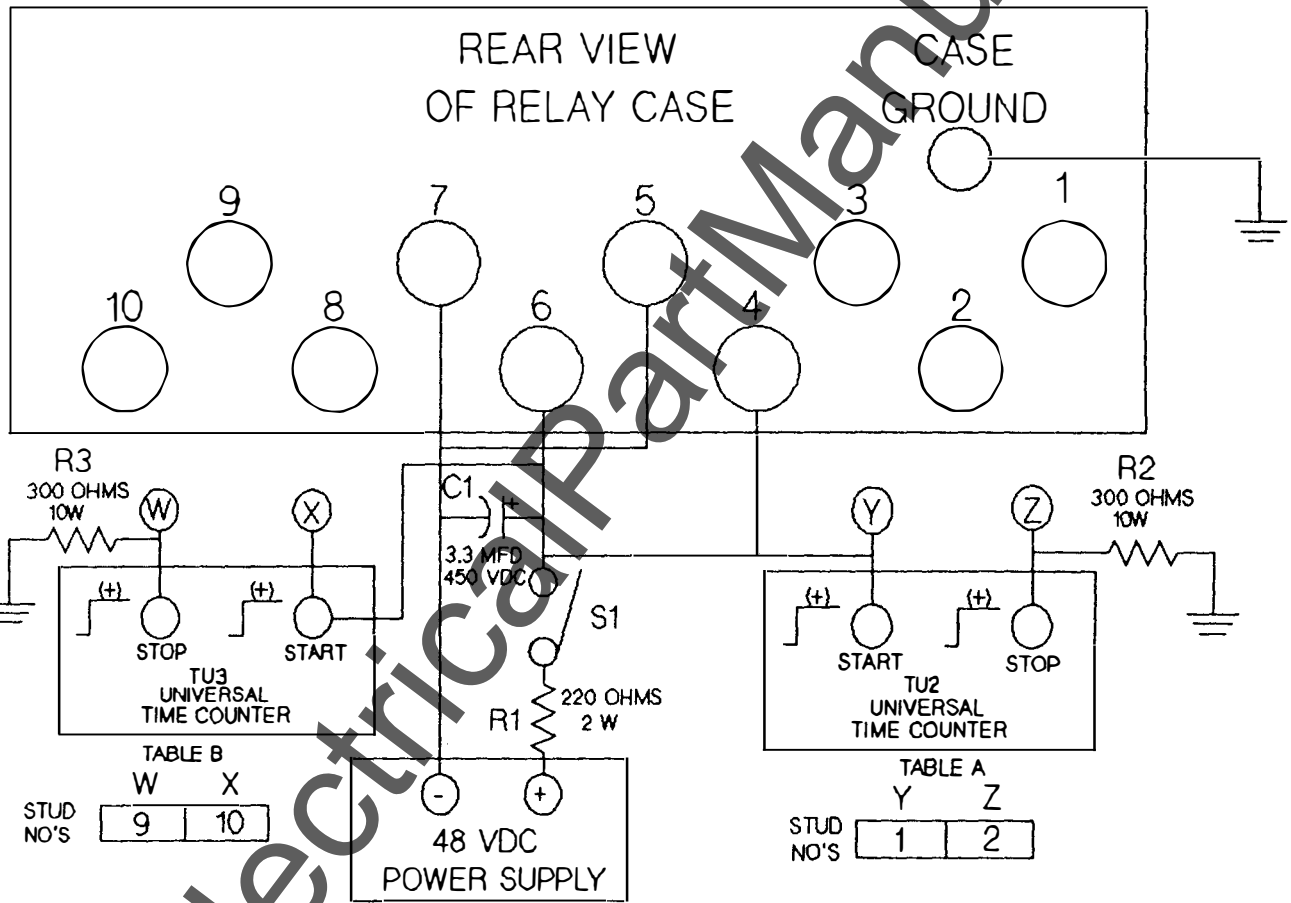

Figure 19 (0286A1863) Timing Test Connections for SAM203

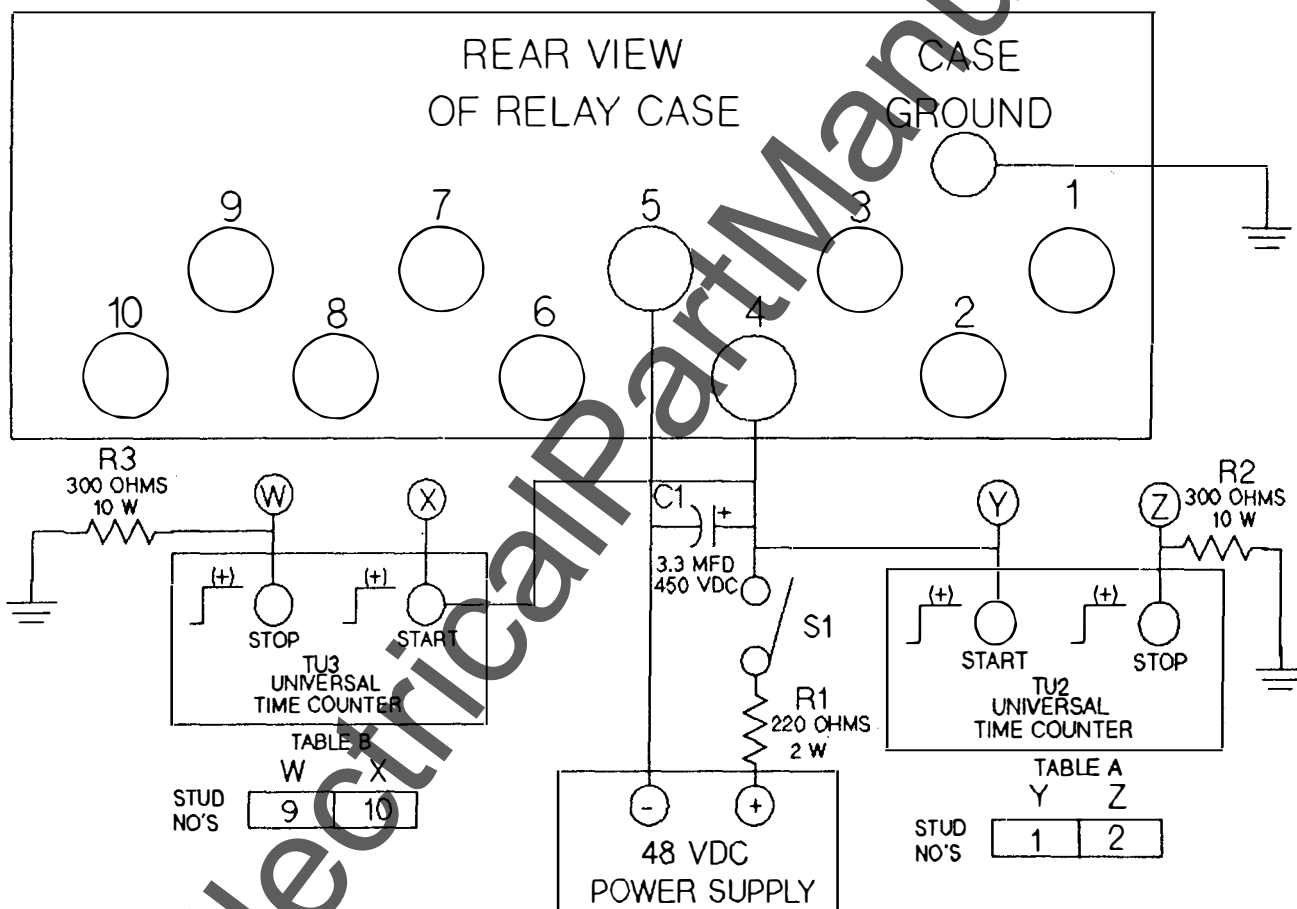

Figure 20 (0286A1864) Timing Test Connections for SAM204

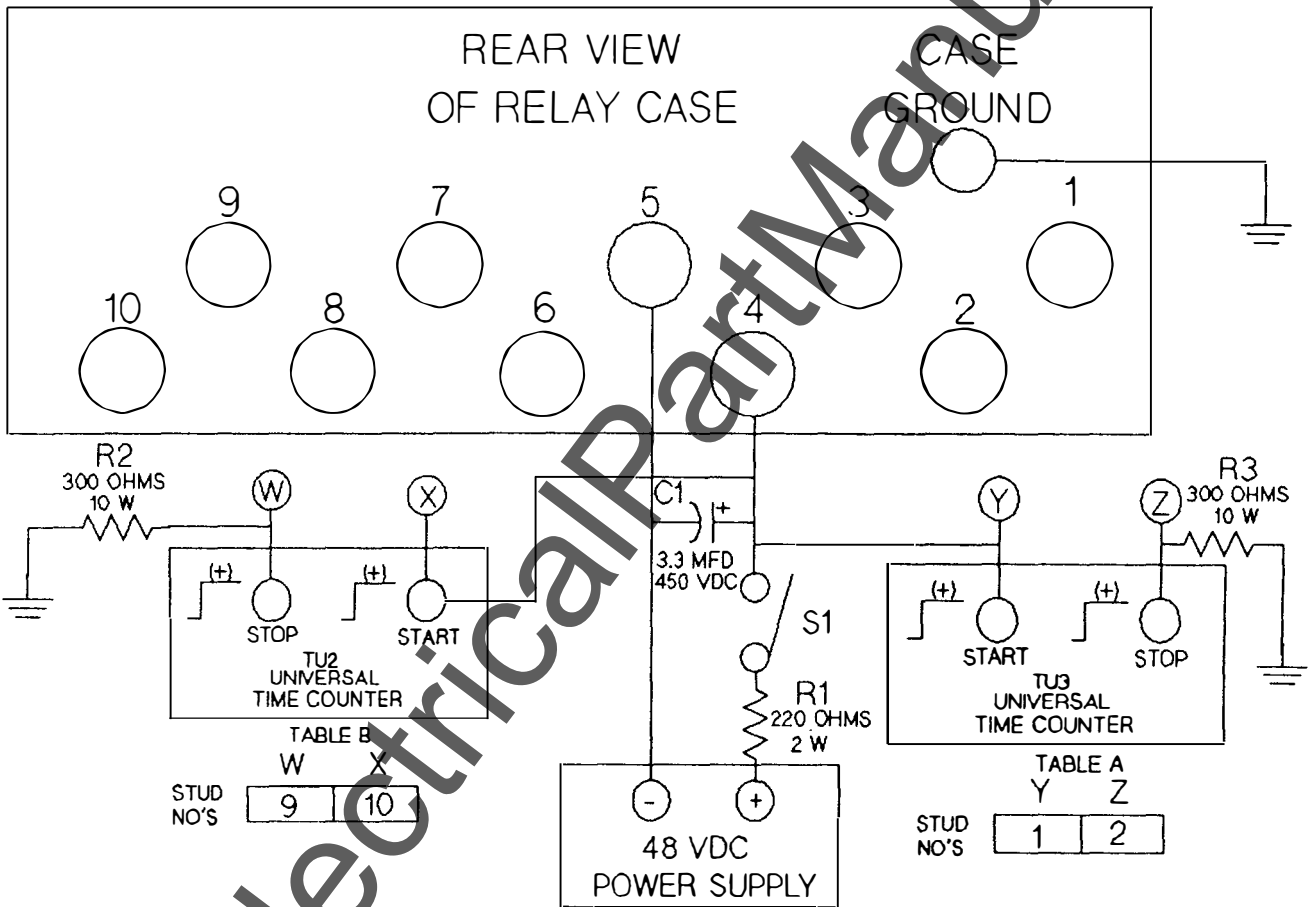

Figure 21 (0286A1865) Timing Test Connections for SAM206



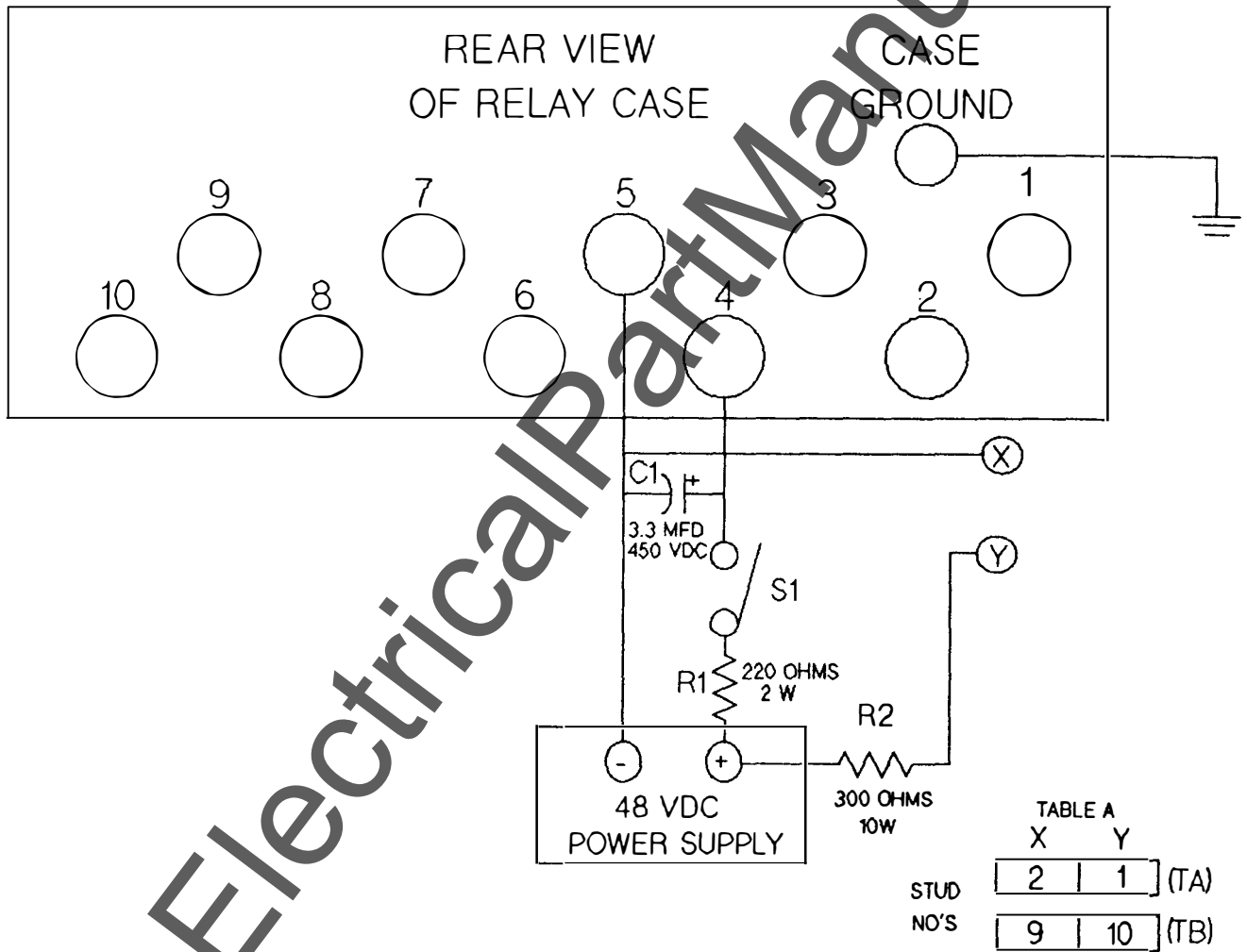
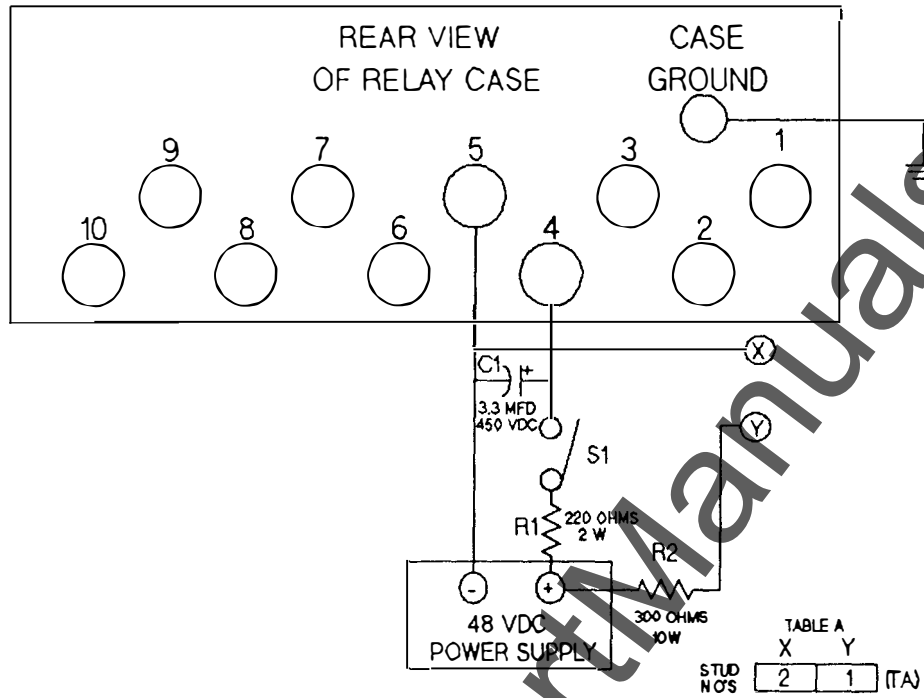
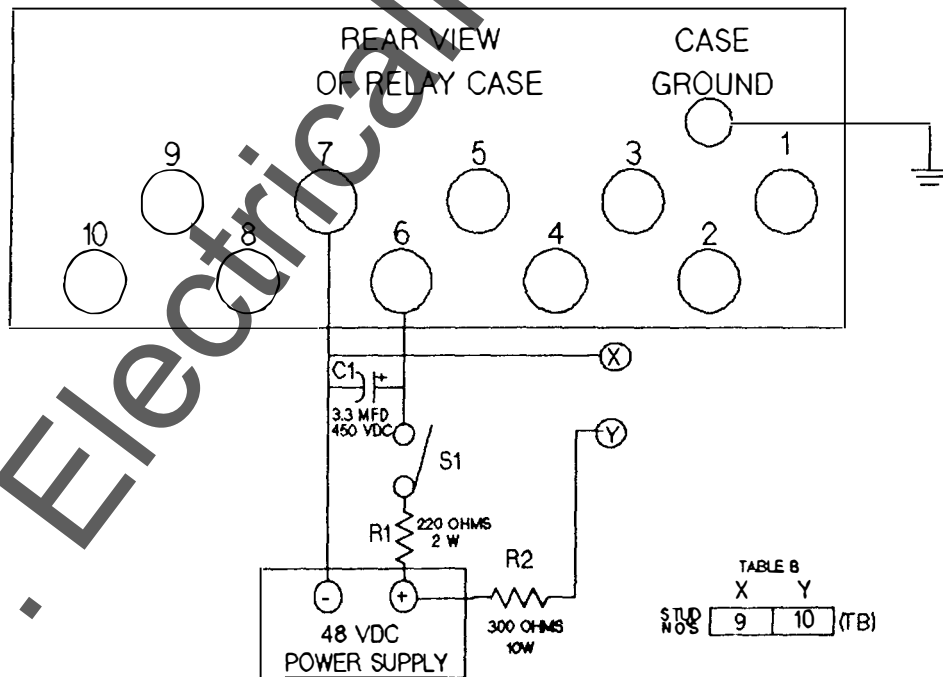

Figure 23 (0286A1867) Target Test Connections for SAM201



USE THIS CONNECTION FOR TARGET TA



USE THIS CONNECTION FOR TARGET TB

Figure 24 (0286A1868) Target Test Connections for SAM203

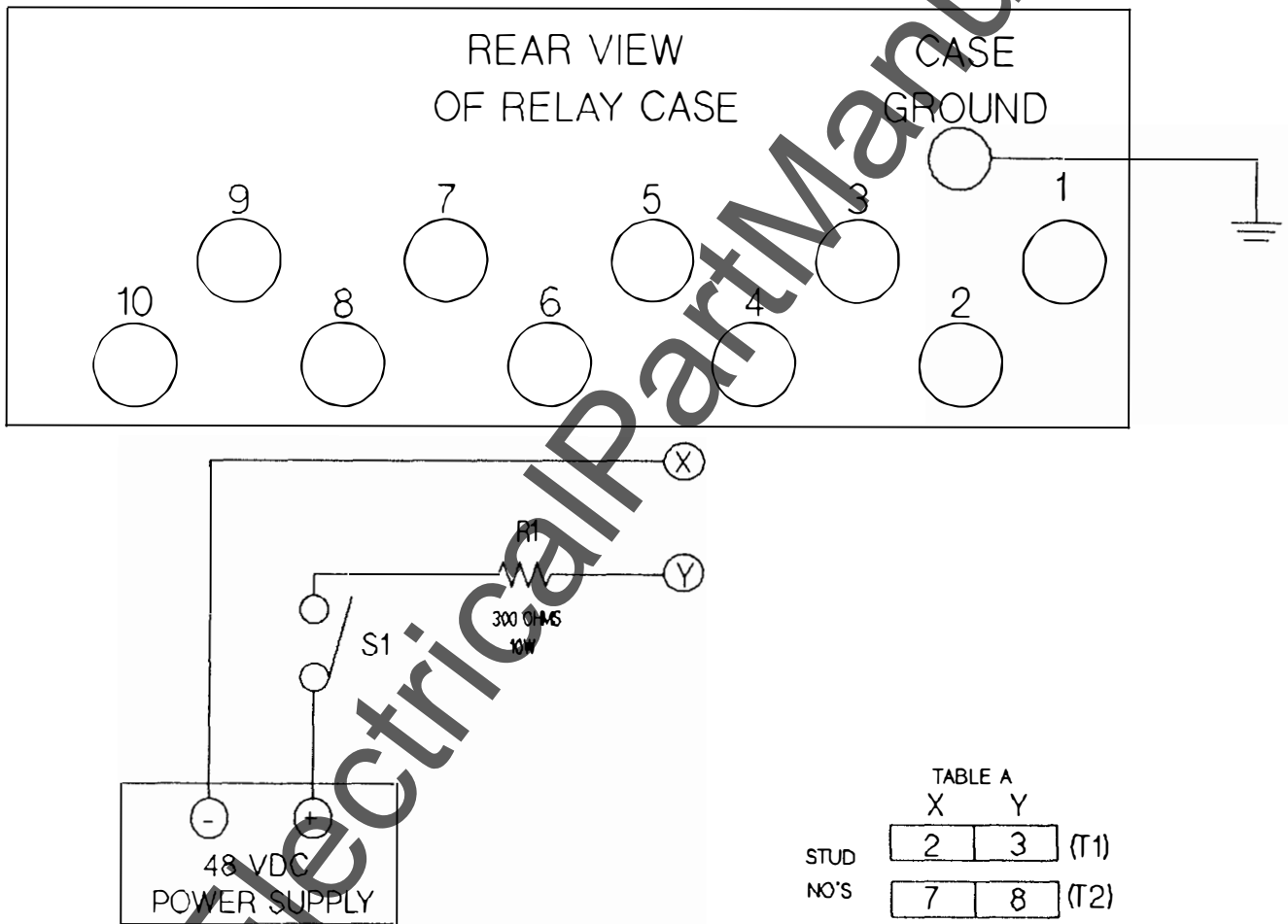

Figure 25 (0286A1869) Target Test Connections for SAM205

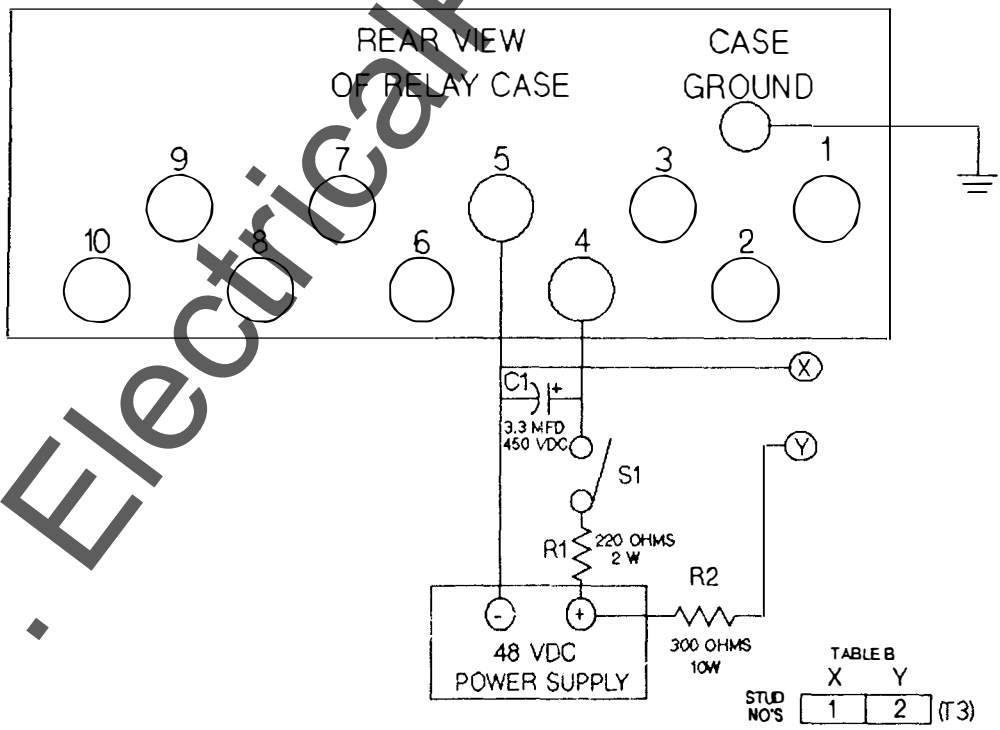
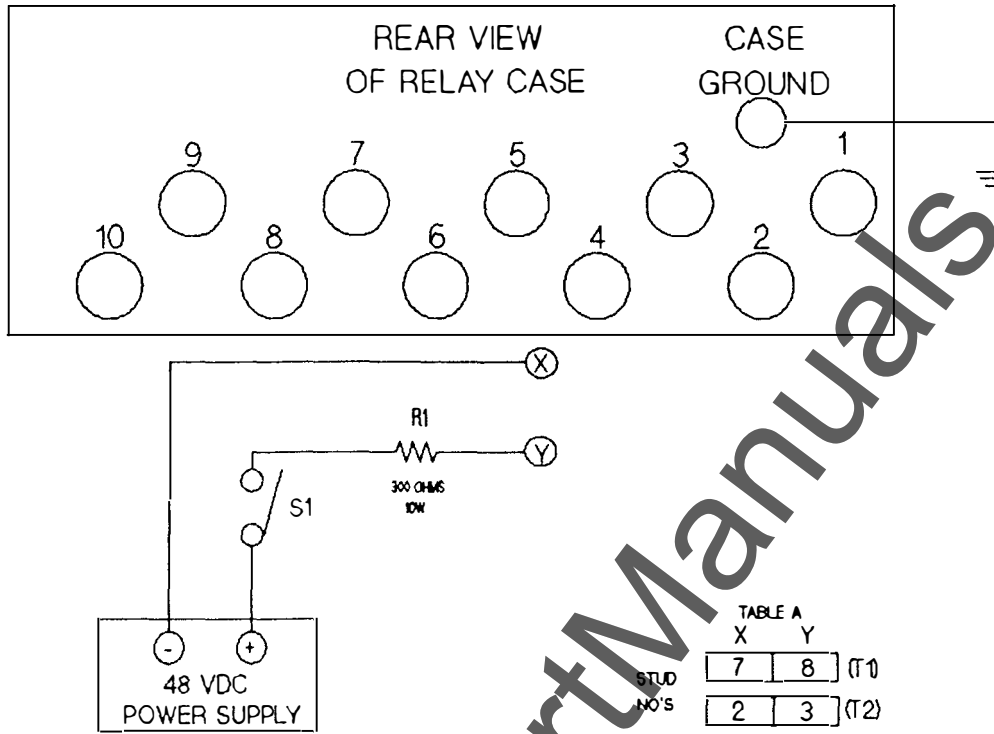
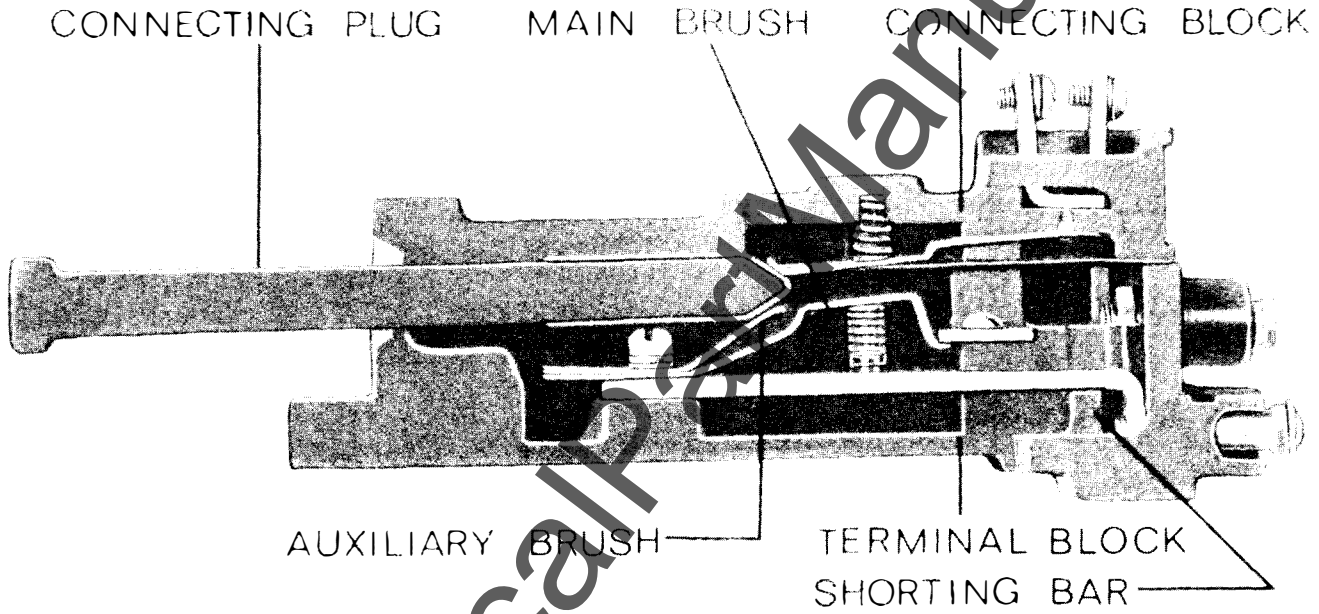
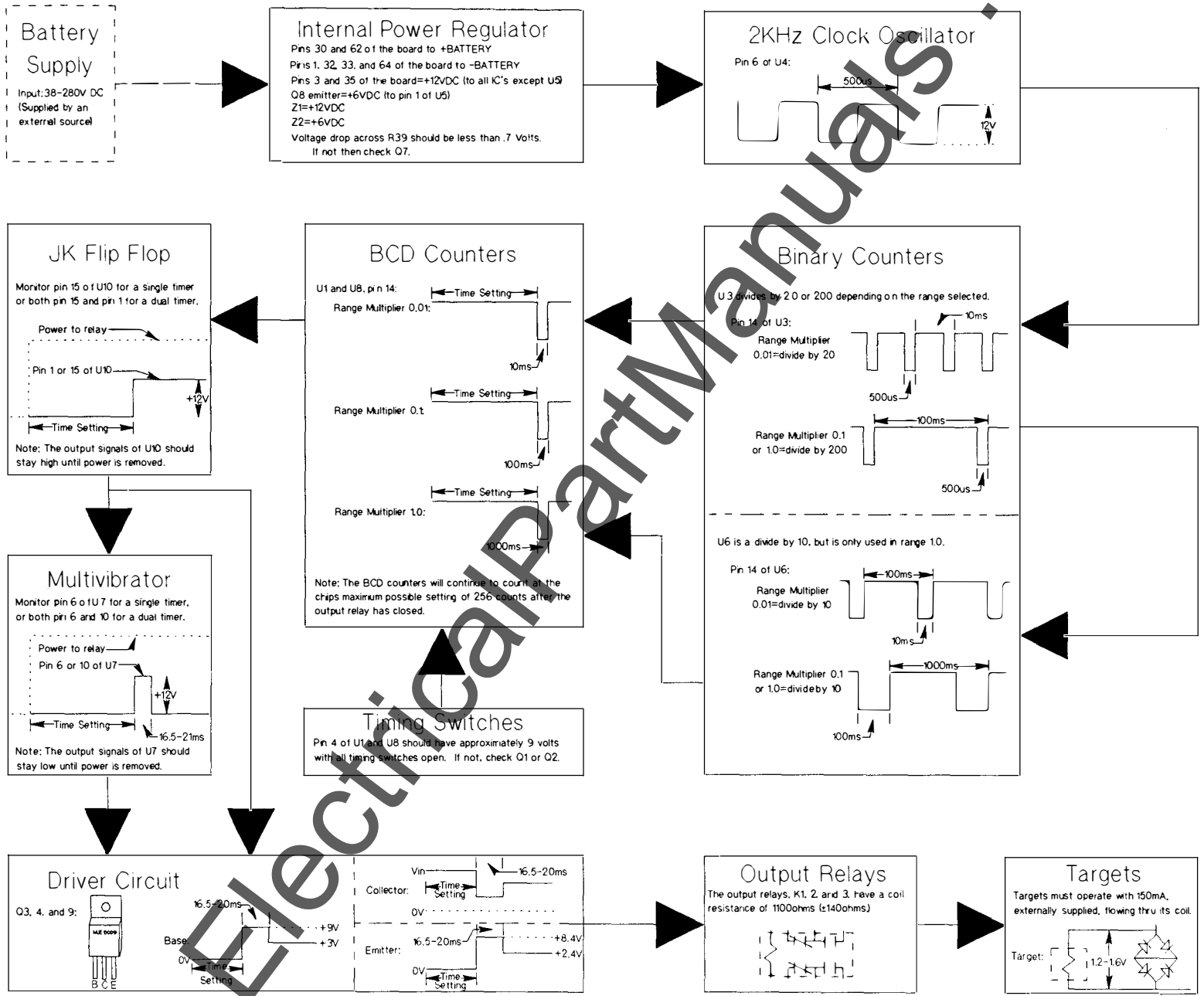

Figure 26 (0286A1870) Target Test Connections for SAM206



NOTE: AFTER ENGAGING AUXILIARY BRUSH CONNECTING PLUG TRAVELS  $\frac{1}{4}$  INCH BEFORE ENGAGING THE MAIN BRUSH ON THE TERMINAL BLOCK

Figure 27 (08025039) Drawout Case Contact Assembly



Note: 12V may vary between 10.4 and 12.4VDC. 6V may vary between 5.3 and 5.9VDC. All other voltages may vary 10% of their specified values.

Figure 28 (0153D7769) Trouble-Shooting Diagram for the SAM201 - SAM207

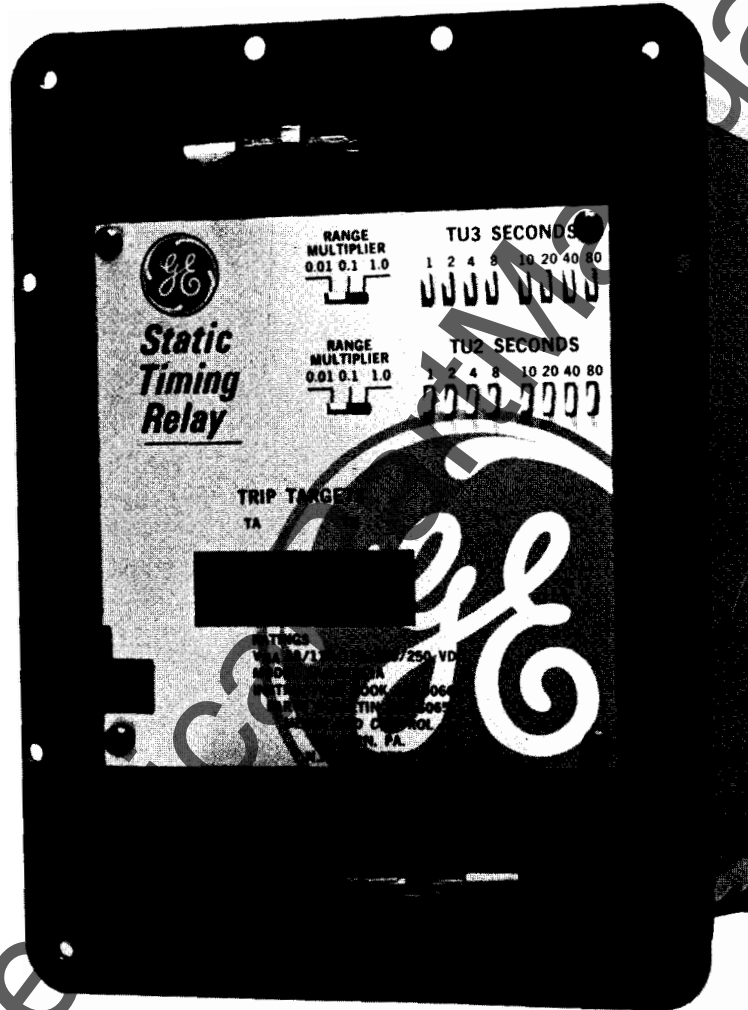

Figure 29 (8043819) Front View of the SAM203 With the Cover Removed

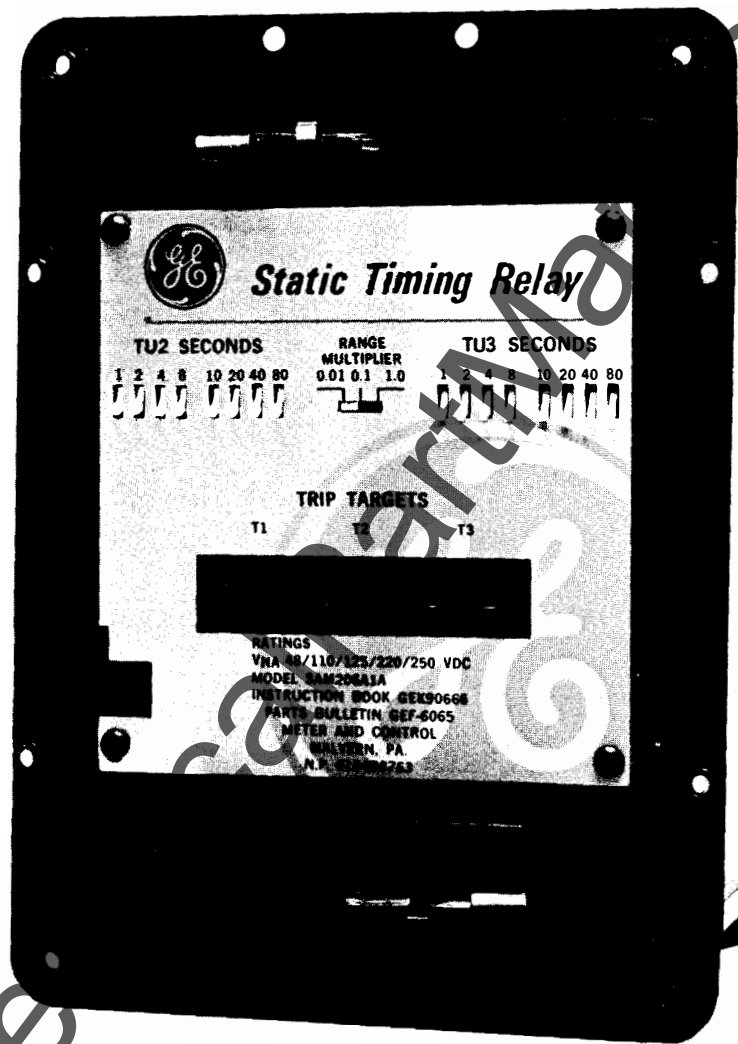

Figure 30 (8043820) Front View of the SAM206 With the Cover Removed

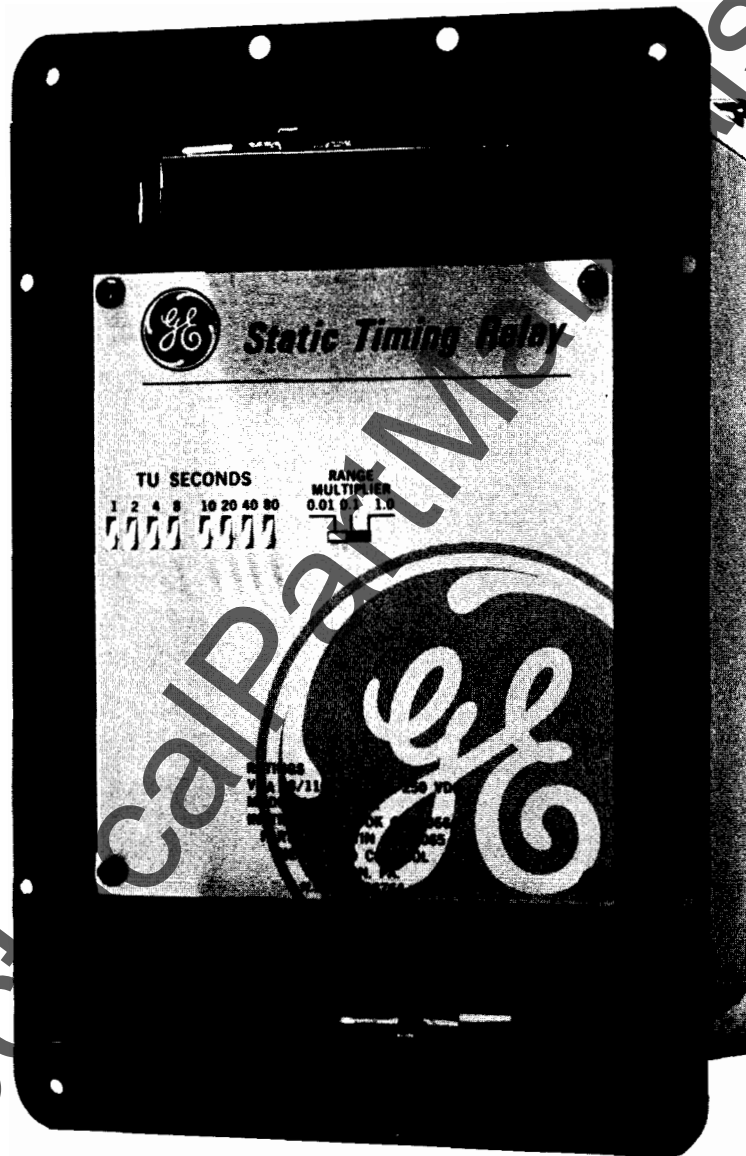

Figure 31 (8043821) Front View of the SAM207 With the Cover Removed

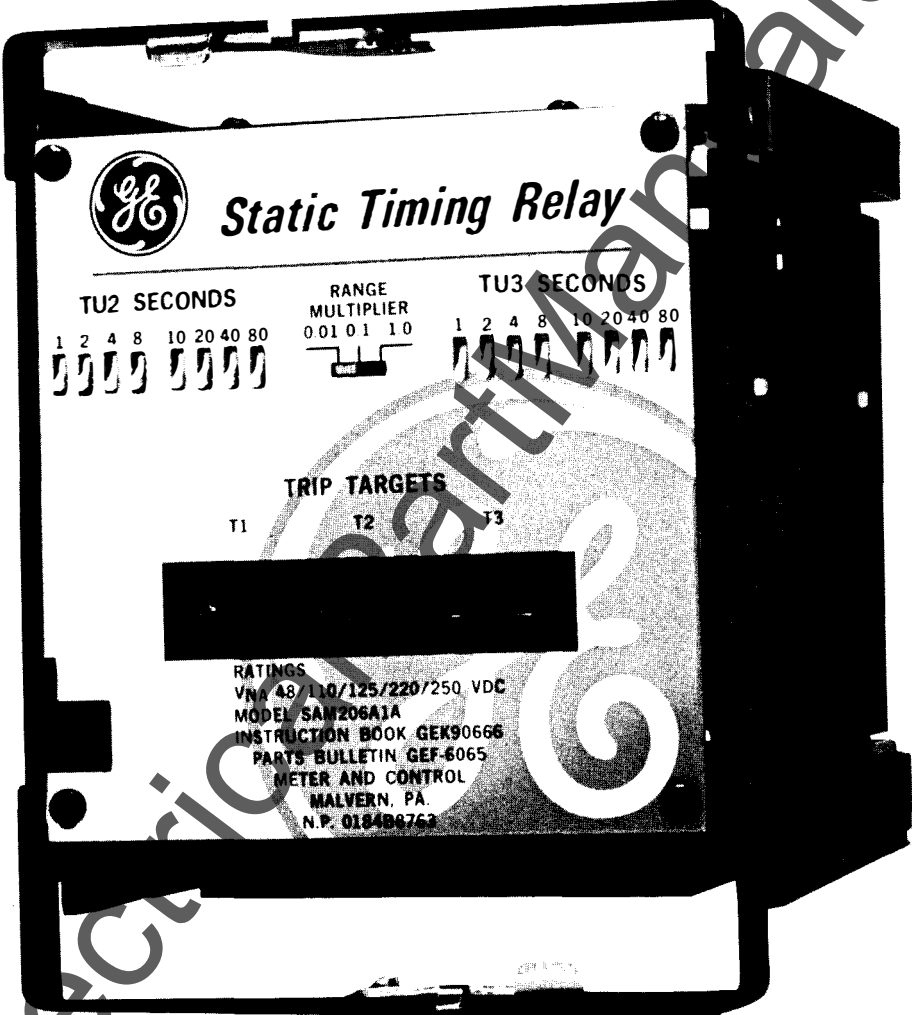

Figure 32 (8043822) Typical "S1" Cradle Assembly Removed from Case

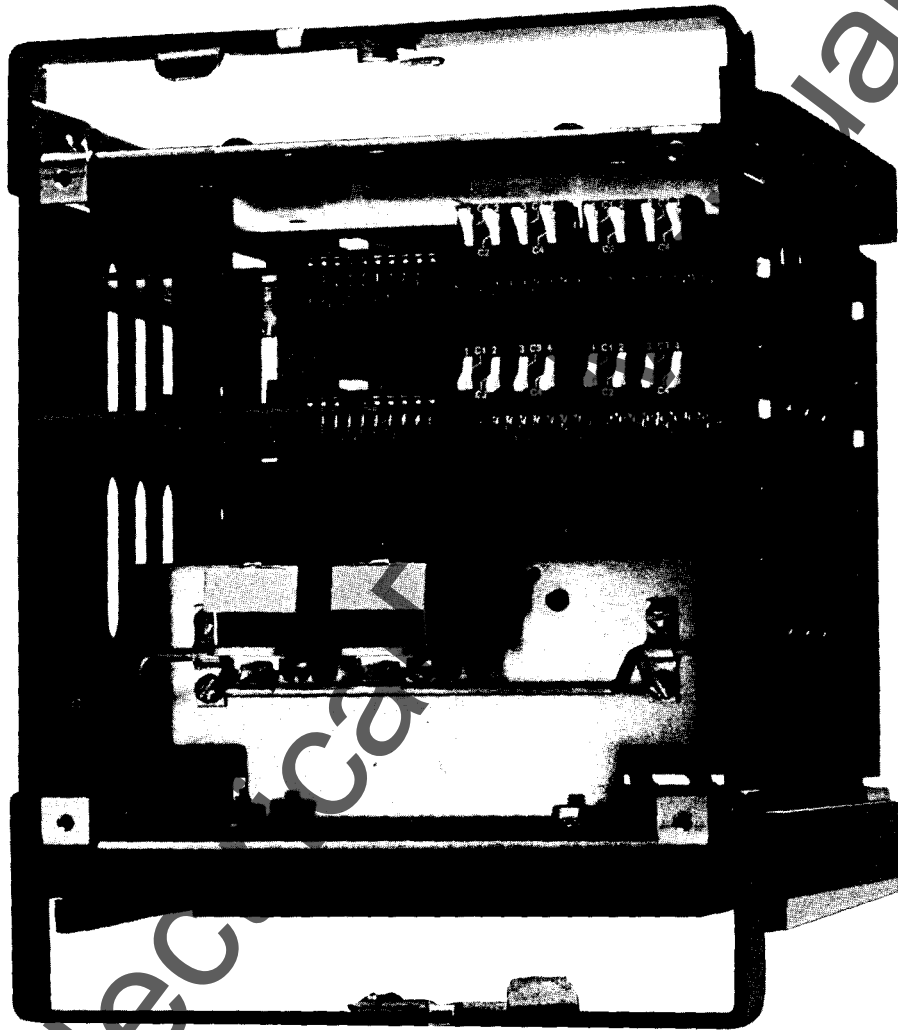

Figure 33 (8043823) Typical "S1" Cradle Assembly With Nameplate Removed

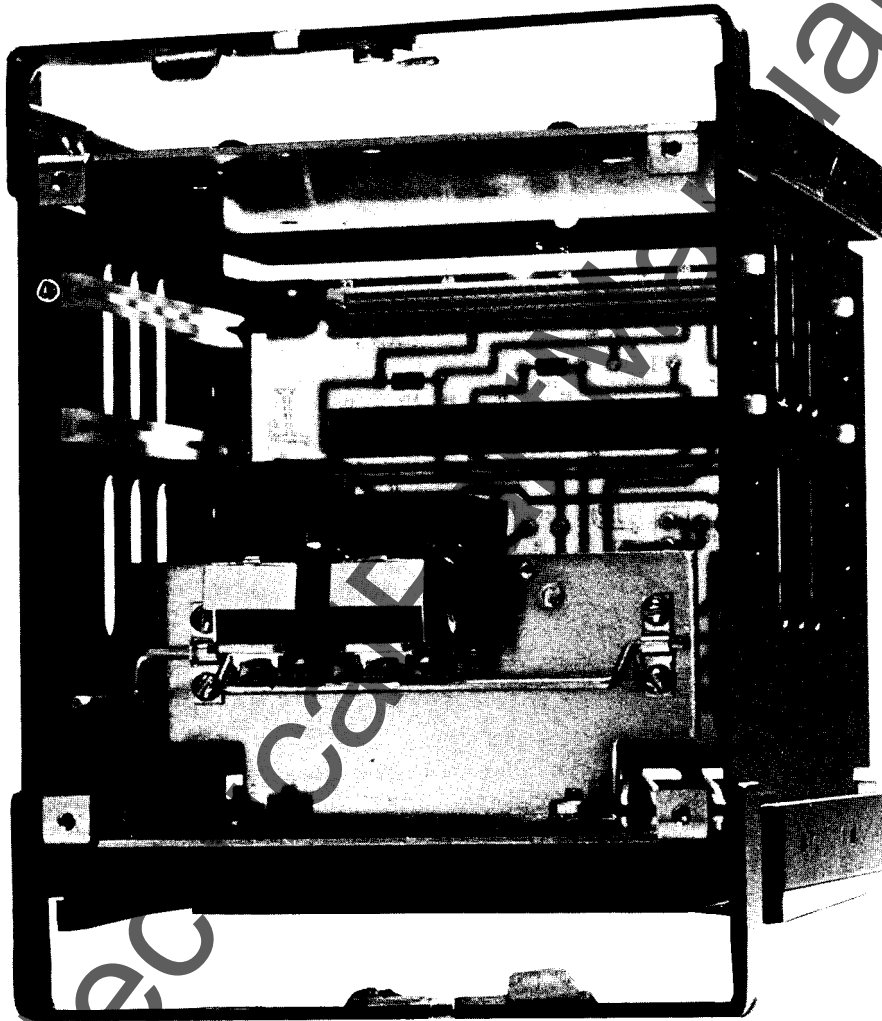

Figure 34 (8043824) Typical "S1" Cradle Assembly With Nameplate and Circuit Boards Removed

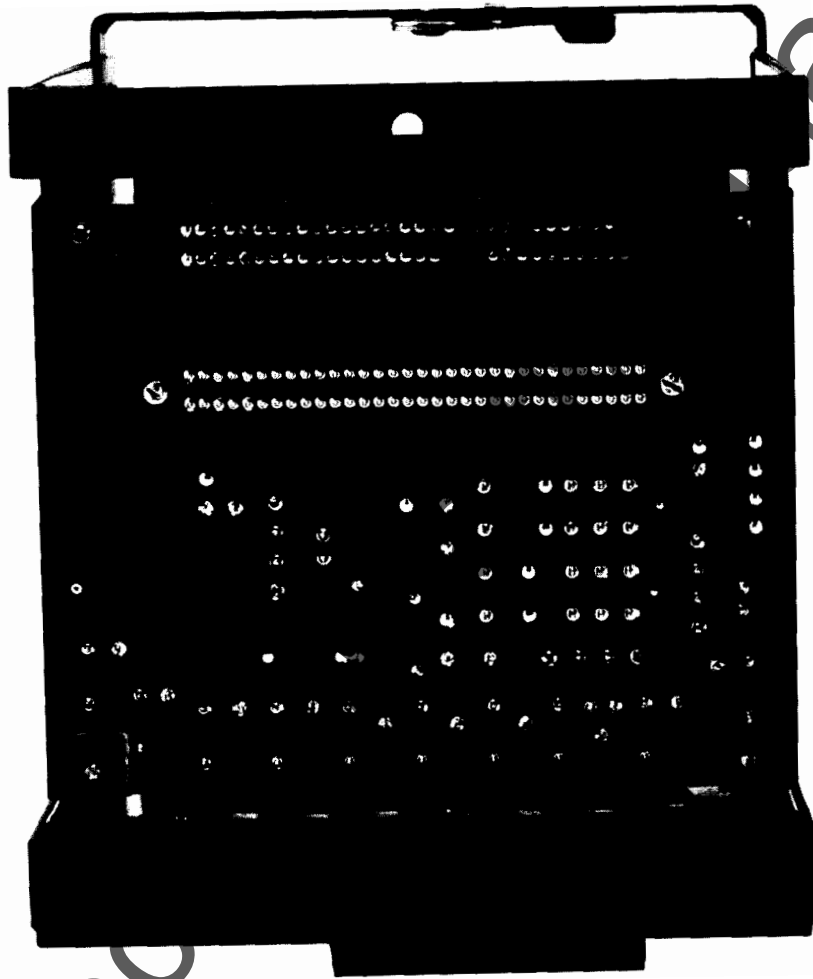

Figure 35 (8043825) Rear View of a Typical "S1" Cradle Assembly

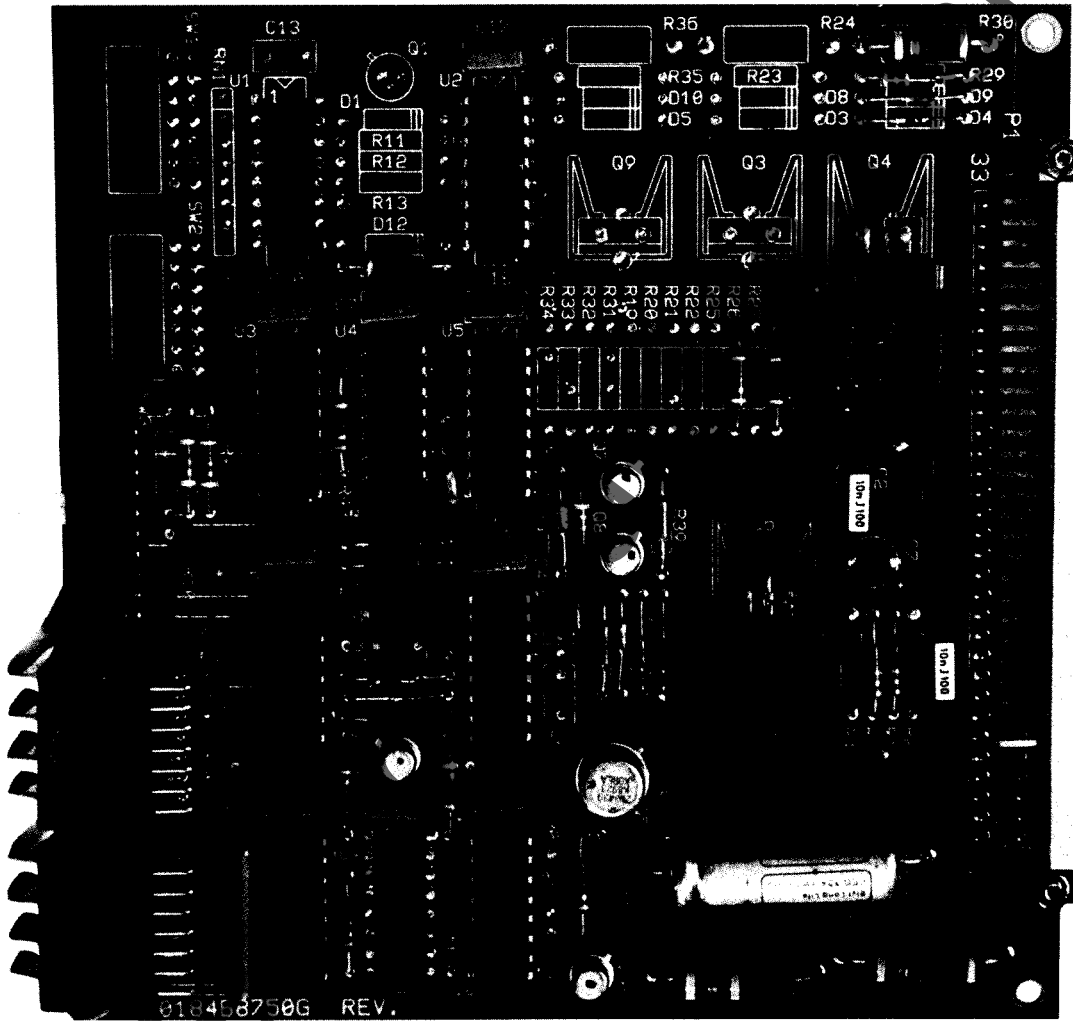

Figure 36 (8043826) View of a Typical Timer P/C Board Assembly

www.electrical.com

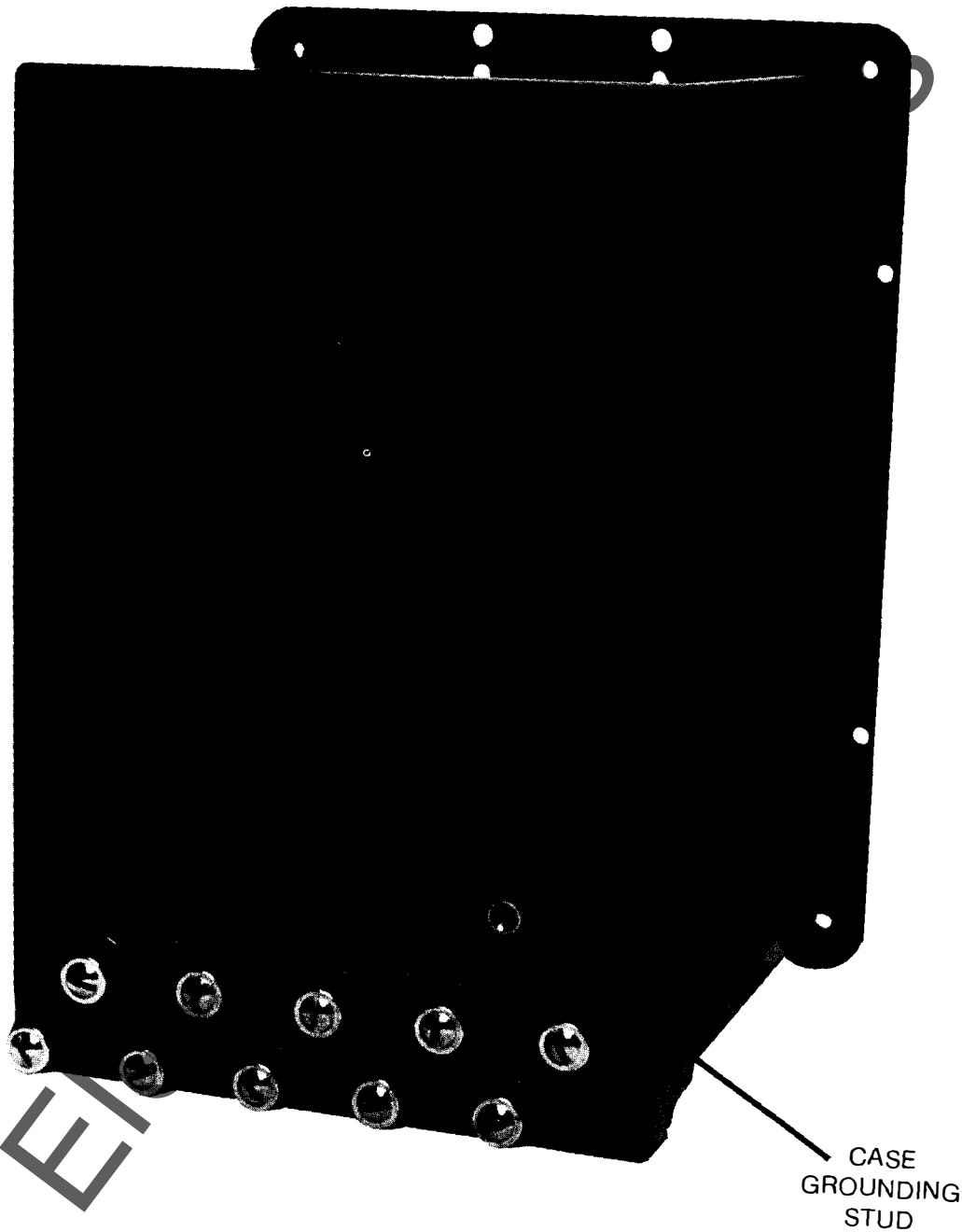
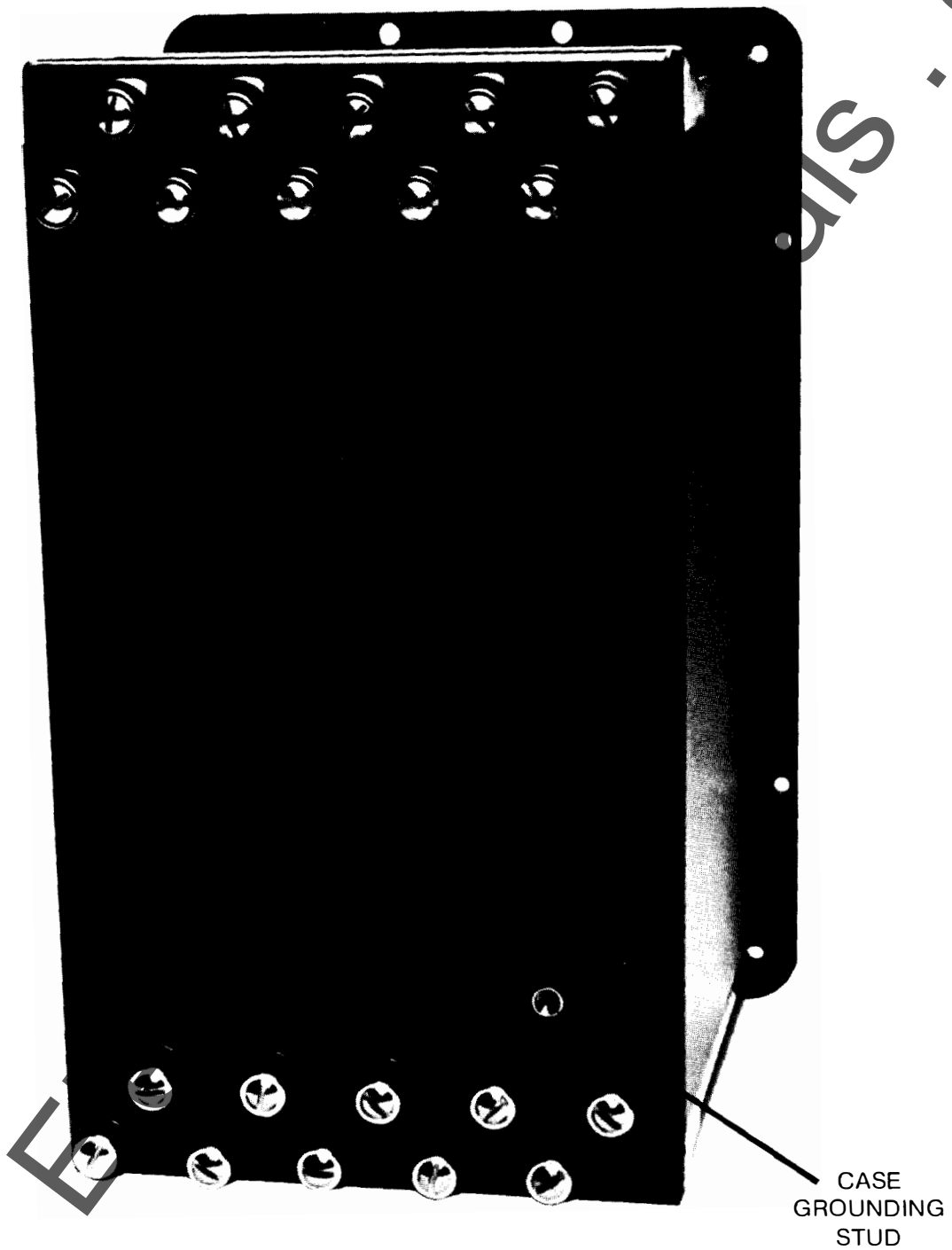

Figure 37 (8043827) Rear View of a Relay Case (S1) With Surge Ground Stud Location



CASE  
GROUNDING  
STUD

Figure 38 (8043828) Rear View of a Relay Case (S2) With Surge Ground Stud Location

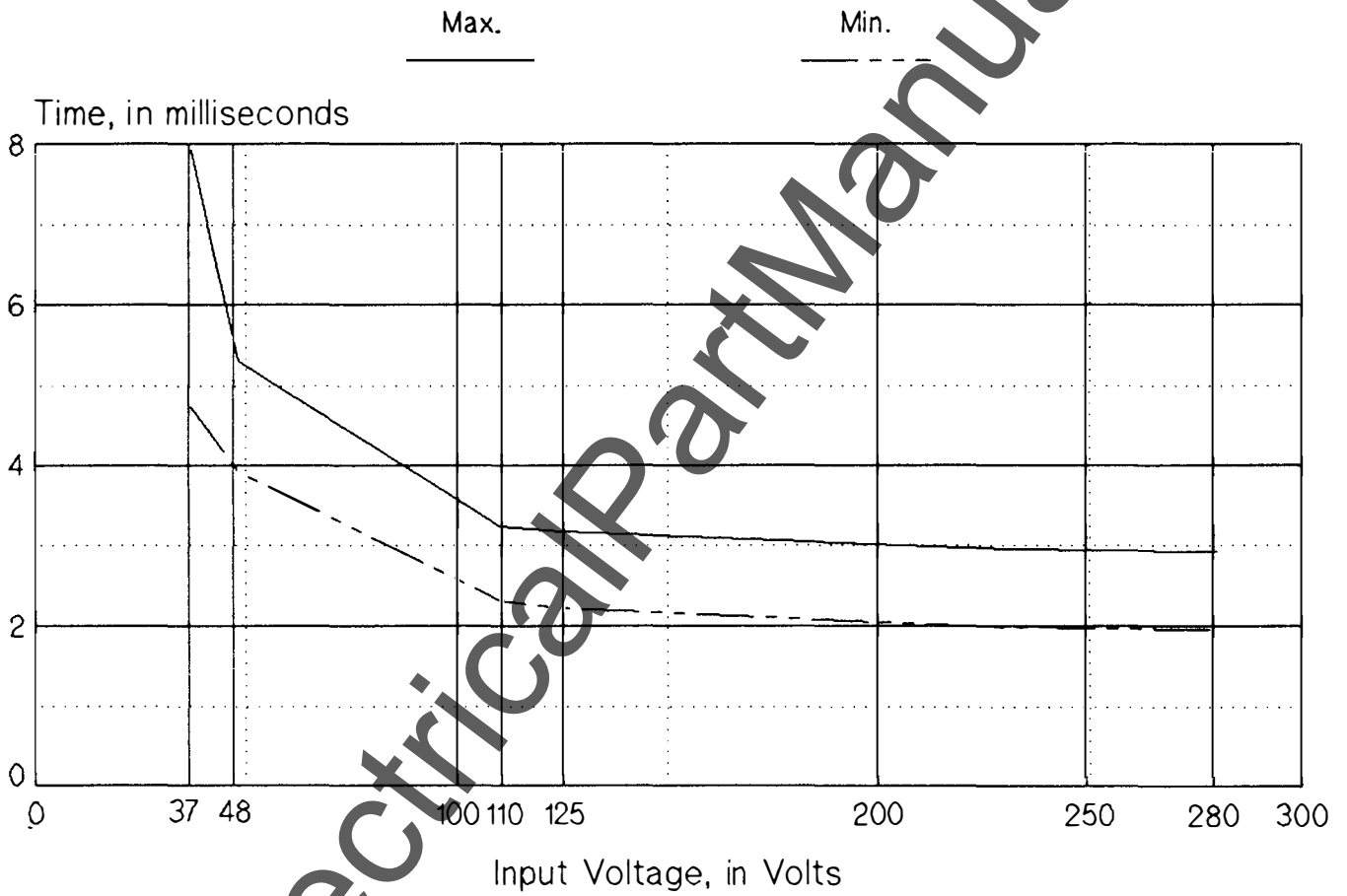
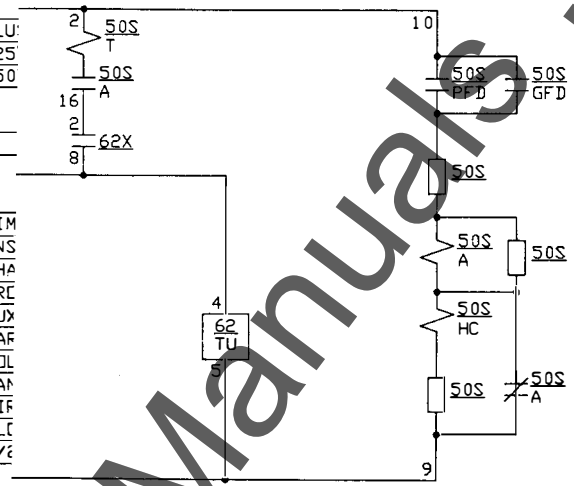

Figure 39 (0286A1873) Output Relay Operating Time

TABUL
TYPE OR DESCRIP
SAM202
CHC11A 21A & UP
NGA15A (BACK CONN PROJ)
NGA15A(-)F (BACK CONN FLU)
102L218G-8 RECTIFIER (125
102L218G-9 RECTIFIER (250

DEVICE NUMBER	DEVICE TYPE	INCL ELEM
62	SAM202	TIM
50S	CHC11A	INS
		PFD PHA
		GF D GRE
		A AUX
		T TAF
		HC HOL
86B	HEA	HAN
101	SB1	CIF
		T CLC
62X	NGA15A	1/2



- NOTES:
- 1) IF 50S DEVICE IS (102L218) SHOULD
  - 2) IF WHITE LAMP IS FROM SEALING IN

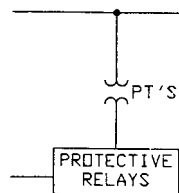

Used in Breaker-Failure Scheme

www.ElectricalPartManuals.com

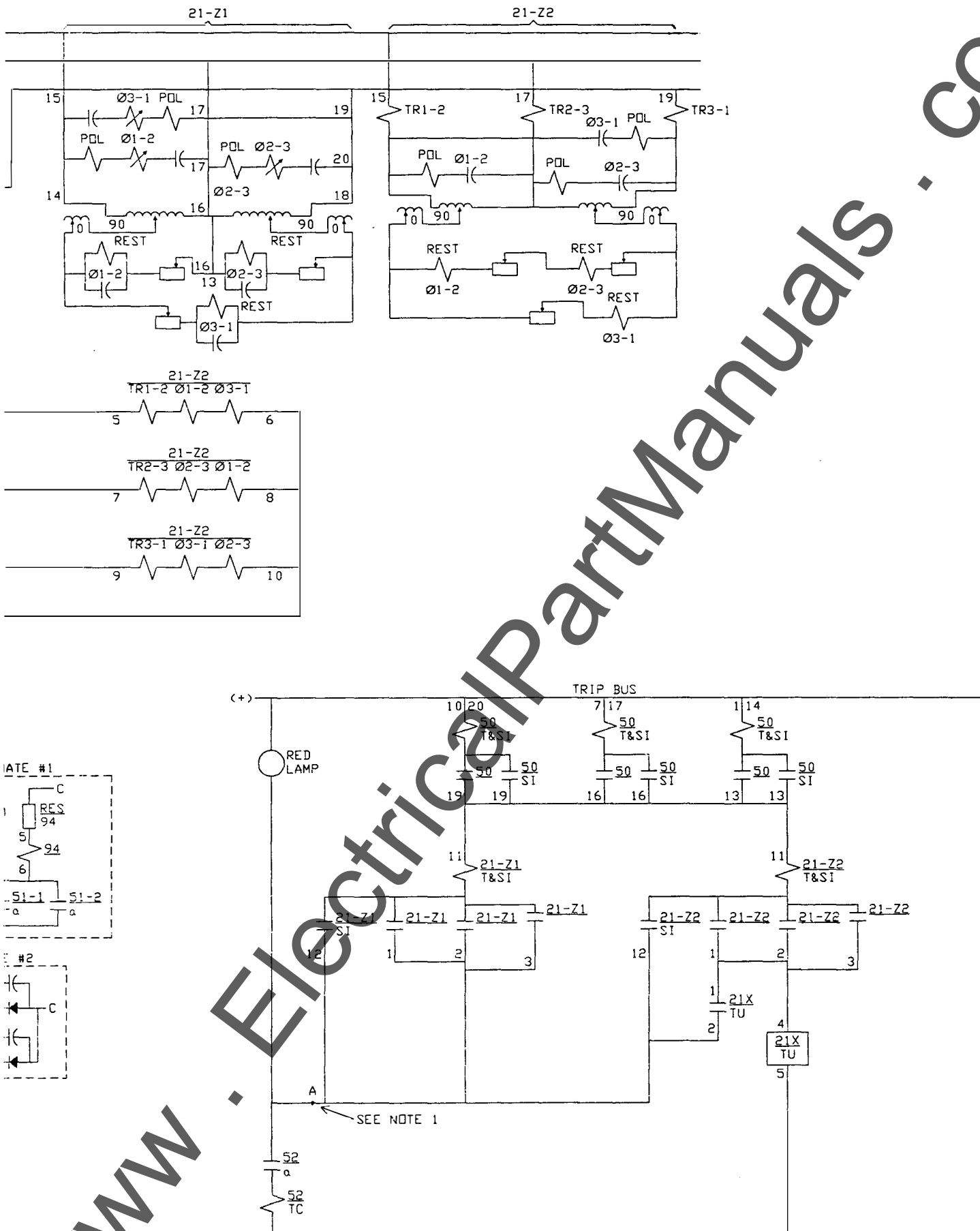

Figure 41 (0153D7810 [2]) SAM202 Used in Two Zone Step Distance Scheme

TABULATION OF DEVICES		
TYPE OR DESCRIPTION	INT CONN	OUTLET
CEY51A	0178A7132	0178A
CEY52A	0178A7133	0178A
CEB52A	0178A7134	0178A
SAM204	018438754	62092
PJC32C	K-6375726	62092
HGA14AM (BACK CONNS)	6400533	64005.5
HGA14AL (FRONT CONNS)	377A139	377A1
TRIP RECTIFIER 102L218G-8 (125V)		104A8
TRIP RECTIFIER 102L218G-9 (250V)		104A8

LEGEND			
DEVICE NUMBER	DEVICE TYPE	INCL ELEM	DESCRIPTION
21-Z1	CEY51A		3 PHASE-1ST ZONE MHO RELAY
		Ø1-2	PHASE 1-2 UNIT ETC
		TR1-2	PHASE 1-2 TRANSACTOR ETC
		T&S1	TARGET AND SEAL-IN UNIT
21-Z2	CEY52A		3 PHASE-2ND ZONE MHO RELAY
		Ø1-2	PHASE 1-2 UNIT ETC
		T&S1	TARGET AND SEAL-IN UNIT
21-Z3	CEB52A		3 PHASE-3RD ZONE OFFSET MHO RELAY
		Ø1-2	PHASE 1-2 UNIT ETC
		TR-1	PHASE 1 TRANSACTOR ETC
		T&S1	TARGET AND SEAL-IN UNIT
21X	SAM204		TIMING RELAY
		TU	TIMING UNIT
50	PJC32C		INSTANTANEOUS PHASE FAULT DETECTOR
		T&S1	TARGET AND SEAL-IN UNIT
94	HGA14AM OR AL		AUXILIARY TRIPPING RELAY

NOTES:

- IF TRIPPING ONLY ONE BREAKER, MAKE CONNECTIONS AS IF USING AUXILIARY TRIPPING RELAY (94) TO TRIP TWO BREAKERS. USE CONNECTIONS SHOWN IN ALTERNATE #1 BY CONNECTING A TO C. IF RECTIFIERS ARE USED TO TRIP BREAKERS, USE ALTERNATE CONNECTION #2. BY CONNECTI
- FOR REVERSED THIRD ZONE, REVERSE THE CONNECTIONS T 5 & 6, TO STUDS 7 & 8, AND TO STUDS 9 & 10 OF 21-Z

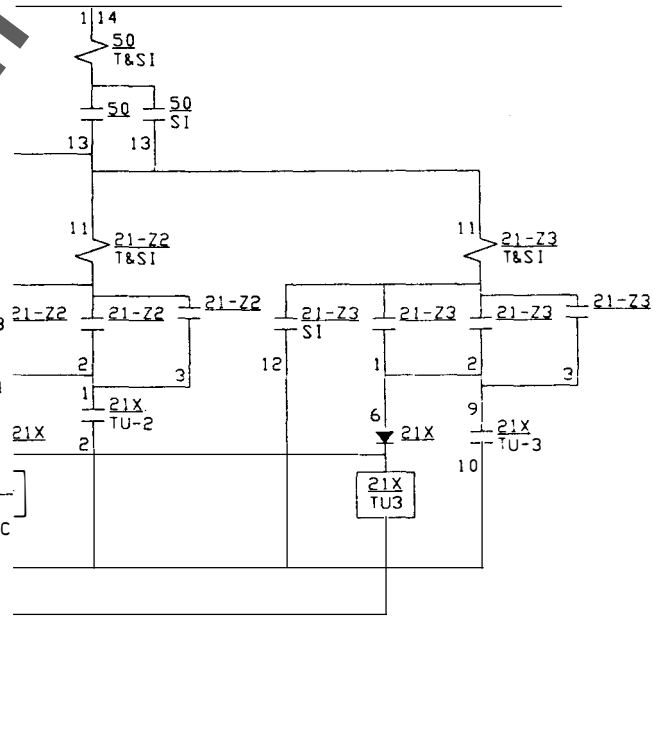
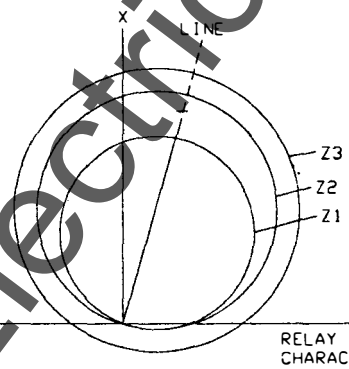
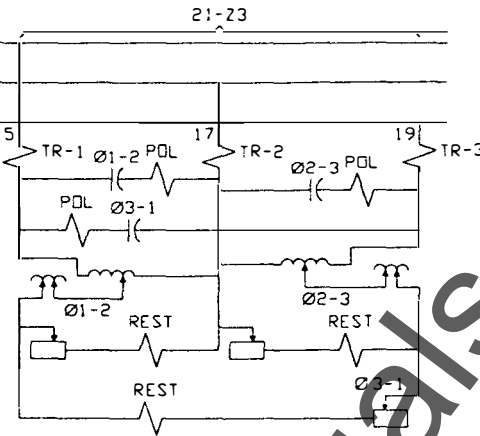

1 in Three-Zone Step Distance Scheme

www.ElectricalPartManuals.com

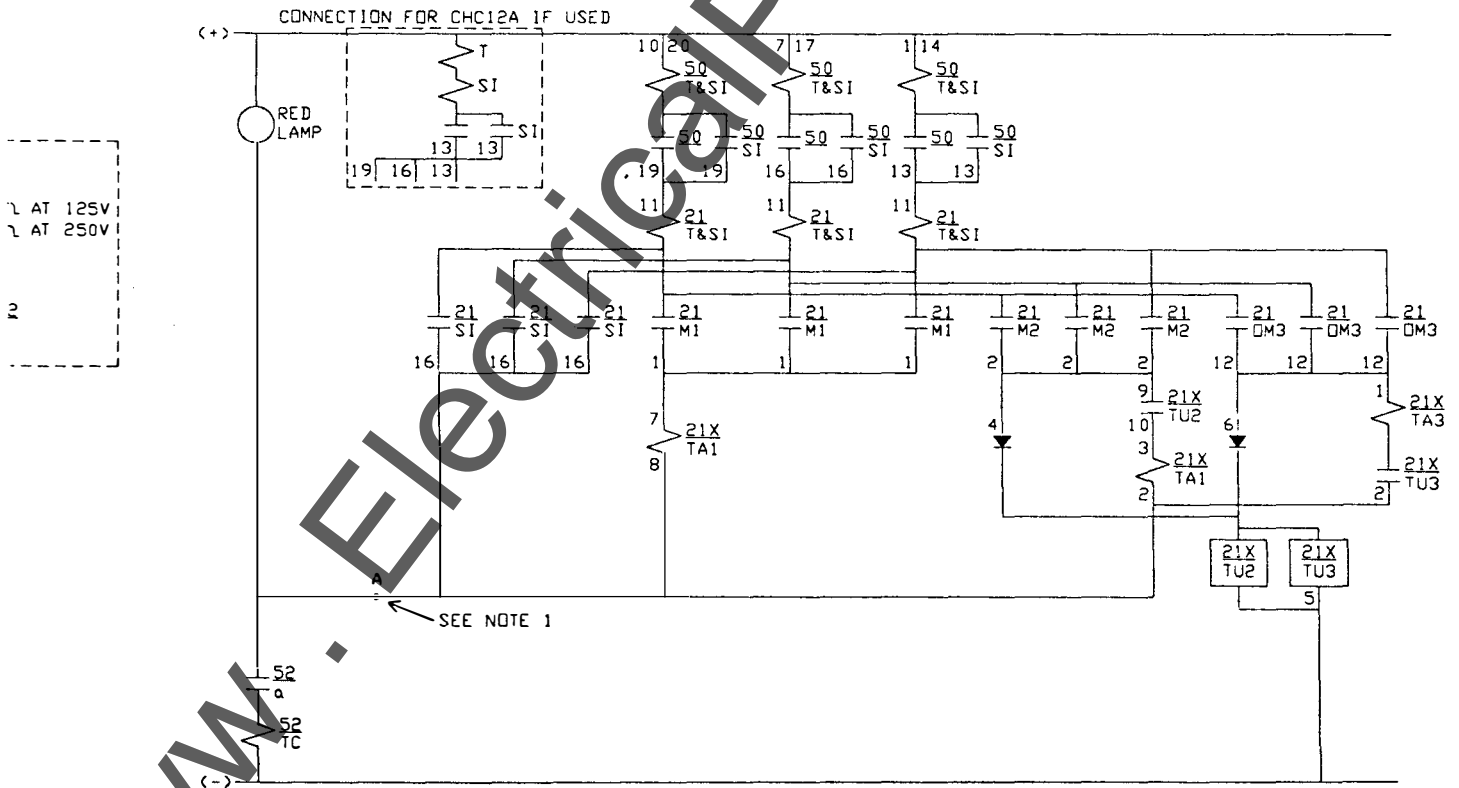
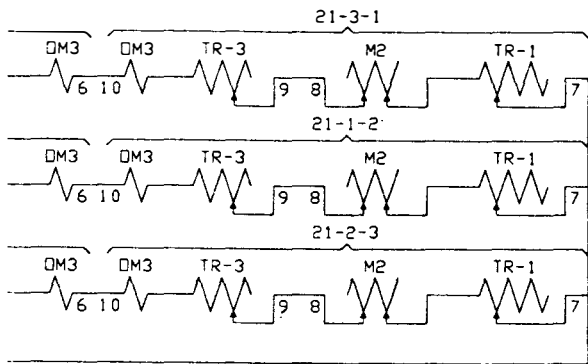
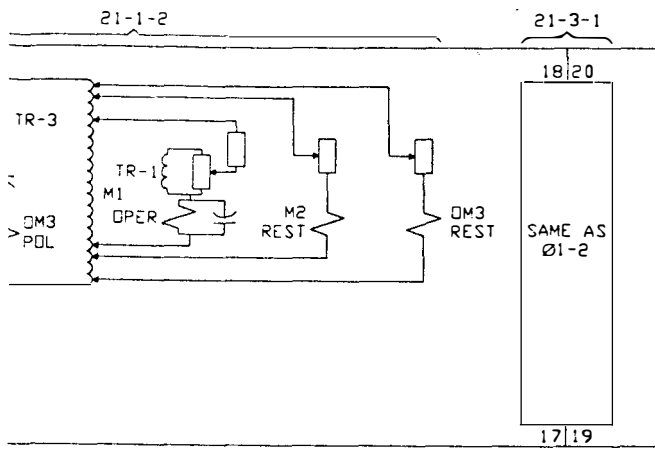

Figure 43 (0153D7812 [1]) SAM206 Used in Three-Zone Step Distance Scheme

[www.ElectricalPartManuals.com](http://www.ElectricalPartManuals.com)

[www.ElectricalPartManuals.com](http://www.ElectricalPartManuals.com)

[www.ElectricalPartManuals.com](http://www.ElectricalPartManuals.com)

www.ElectricalPartManuals.com

**Protection and Control**

(2/94) (1500)

---

*GE Technology Center  
205 Great Valley Parkway  
Malvern, Pennsylvania 19355-1337*