

# GROUND PROTECTION SYSTEMS

## INSTRUCTIONS

### GROUND-SHIELD® GROUND FAULT PROTECTIVE SYSTEM

TYPE GR-200 (200-2000 AMPERES) SURFACE AND DRAWOUT MOUNTED

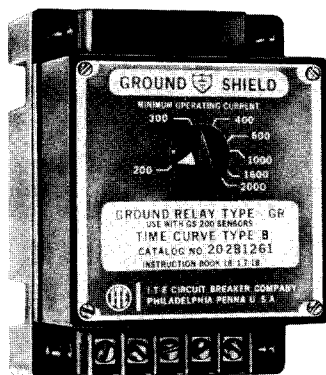
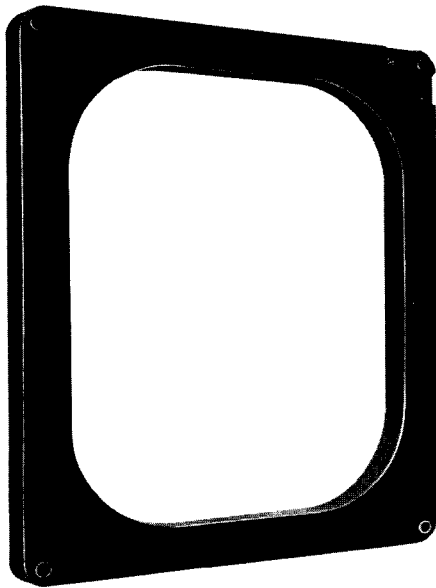



## INSTRUCTIONS FOR GROUND-SHIELD GROUND FAULT PROTECTIVE SYSTEM TYPE GR-200 (200-2000 AMPERES) SURFACE AND DRAWOUT MOUNTED

### APPLICATION

The GROUND-SHIELD ground fault protective system provides fast sensitive protection against all ground faults on grounded electrical distribution systems. The system consists of a special design current transformer which is called a ground sensor and a solid state relay. The ground sensor encircles all phase conductors and the neutral conductor if supplied, and provides an output to the ground relay when a ground fault occurs in the circuit. The ground relay operates the shunt trip device on the circuit breaker.

In some applications, the ground sensor can be put around the neutral connection to ground to operate the main protective device.

### RECEIVING, HANDLING, STORAGE

Upon receipt of the GROUND-SHIELD system (when not included as a part of a switchboard) examine for shipping damage. If damage or loss is evident, file a claim at once and promptly notify the nearest I-T-E Imperial Corporation Sales Office. Use normal care in handling to avoid mechanical damage. The GROUND-SHIELD system has no moving parts and if kept reasonably clean and dry, has no practical limit to its operating life.

### MAINTENANCE AND RENEWAL PARTS

No maintenance is required on the GROUND-SHIELD system. Should the relay be damaged physically or electrically due to improper connections or application, it is recommended that a new relay be ordered from the factory. When ordering the relay, state the type relay, catalog number, control voltage and serial number of the relay.

### SIZE AND RATING

Application to circuits is independent of circuit current rating. Sensors are selected by physical opening necessary to accommodate conductors.

Relays are selected by the time current curve characteristic desired, control voltage of the system, and type mounting required.

### INPUT AND OUTPUT CIRCUIT DUTY RATINGS

For input and output circuit duty ratings, refer to tables shown at top of page 6.

### ALARM CONTACT

On semi-flush relays, where ordered, a single pole double throw contact is wired to the relay rear terminals 9, 10 and 11 for additional use. (9 to 10 normally open, 10 to 11 normally closed.) The rating of this contact is 3 amperes con-

tinuous. To accomplish this feature with the surface relay, an auxiliary relay is required.

### INSTALLATION

#### MOUNTING

The sensor should be mounted so as to enclose all phase conductors and the neutral conductor if supplied (but not the ground conductor). For applications other than dual source, the connection between neutral and ground must be made ahead of the sensor. In applications where the neutral connection to ground is readily available, the sensor can be mounted on this connection. On four wire systems with dual sources, special consideration must be given to the mounting of the sensors. Check the factory on the use of the Charge Control relay for these applications.

Cable conductors should be bundled tightly and centered in the sensor window. Rectangular sensors should be applied with 1½ inch or more clearance from the sensor to the nearest current carrying bus. The sensor should not be mounted in a manner that would put stress on the mounting bushings.

For information on installation of split sensors, refer to top of page 5.

Ground sensors should be short circuited during maintenance periods. This will prevent the presence of moderate sensor output voltages (less than 100 volts) if a ground should occur during the maintenance period. The sensor mounting dimensions are shown in Figures 1 and 2 for round and rectangular sensors respectively.

The relay should be mounted in a location where the pick-up setting is accessible and can be adjusted at any time without danger to the operator. Relay mounting dimensions are shown in Figures 3 and 4. Relays are available in surface mounted and semi-flush panel mounted type cases. The semi-flush relay has drawout facilities.

When mounting a ground sensor over shielded cable or metal sheathed cable, certain precautions must be taken so that proper relay operation is assured.

#### Shielded Cable

On shielded cable, the shielding tape must be connected to ground at a point on the cable side (opposite switchgear bus side) of the current sensor. If the ground wire is connected to the shield on the switchgear bus side of the sensor window, the ground wire must be brought back through the sensor window before being connected to the ground bus.

#### Metal Sheathed Cable

When a ground sensor is applied over sheathed cable which is terminated at a pothead, the pothead mounting must be insulated from ground (600 volt insulation level) and the ground wire from the pothead body brought back through the sensor window before being connected to the ground bus.



## CONNECTIONS

Wiring diagrams are given in Figures 5 to 8. Wires from the sensor to the relay should be at least #14 gauge wire and no more than 100 feet in length. Larger wire should be used for greater distances. Total lead resistance of wires from sensor to relay should be no more than 0.5 ohm.

A circuit breaker auxiliary switch 52a, should always be used in series with the shunt trip coils to prevent thermal damage to the tripping circuit.

## SETTINGS

The relay minimum operating current (pick-up setting) is adjustable from 200 to 2000 Amperes. The time current curves of each relay are preset at the factory. The surface type relay has one preselected time curve. The semi-flush mounted relay has three time curves which can be adjusted in the field.

## OPERATION OF AUXILIARY RELAYS WITH GROUND SHIELD RELAYS

The output circuit of the ground shield relay consists of a silicon controlled rectifier (SCR) which is turned on (contact closure) by the timing circuit and is held "on" by the flow of coil current.

In A.C. application, approximately 0.1 amperes is required to insure that the SCR is held on. (The output circuit is designed such that all coils having less than 980 ohms, 60 hz impedance, will guarantee the required holding current down to 90 Vac.

In D.C. application, auxiliary relays with coil resistances greater than 10 ohms/V must have a parallel resistor added across the relay coil. Recommended resistance values are:

NOMINAL VOLTS D.C.	OHMS	MAX. WATTS	RECOMMENDED WATT RATING
48	1000	3.6	20
125	2500	8	20

## TESTING

**NOTE:** It is recommended that a fuse be inserted in series with the control power leads to protect the relay while being tested. This fuse should be a 1 ampere slow blow, such as Chase-Shawmut Cat. No. TRM, or Littelfuse Type 3AG.

## HIGH POTENTIAL TESTS

Do not apply high voltage tests to solid state relay circuits. If a control wiring insulation test is required, bond all terminals together before applying test voltage.

## OPERATION INDICATOR

An operation indicator is provided as a standard feature of the semiflush drawout relay.

The operation indicator shows international orange when the relay operates due to a ground fault. The indicator re-

tains correct status memory independent of control power. Reset is accomplished by pressing the reset pushbutton.

**CAUTION:** Do not poke the orange target with pointed object; it can be easily damaged.

## OPERATIONAL TESTS

It is not necessary to schedule periodic maintenance and testing of this ground protection system. However, if tests are desired to confirm the proper functioning of the ground system, one of the following procedures can be used.

### A. Mounted in Switchgear

Tests should be made on a de-energized main circuit. If tests are to be made on an energized circuit, be sure to take all necessary precautions.

1. Set the relay at 200 ampere pick-up.
2. Loop a test coil of ten (10) turns of approximately #14 wire through sensor (CT) window.
3. Apply control power to the circuit breaker trip circuit.
4. Apply 25 amperes through test coil (250 ampere-turns). The relay will trip the breaker. Immediately return the test current to zero after breaker operation.
5. If breaker does not trip, interrupt the input circuit immediately, then check continuity of trip circuit including trip coil. This can be done by shorting out studs 3 and 4 on surface relay or studs 7 and 12 on semi-flush relay.

**CAUTION:** Relay output SCR will be damaged unless an "a" auxiliary switch opens trip circuit after trip operation.

### B. Bench Test – (without circuit breaker)

1. Connect relay and sensor as shown on page 6.
2. Set the relay at 200 ampere pick-up.
3. Run the primary current up so that approximately 250 ampere-turns are on the sensor primary. Auxiliary relay will pick-up when GR-200 relay operates. Immediately return the test current to zero after relay operation.
4. To repeat test, push reset push-button to drop out auxiliary relay.

## CALIBRATION TESTS

If accurate calibration tests for minimum operating current and time delay are required, they should be made by the primary current method using sensor and relay as a system.

Approximate checks can be made of system pick-up current by monitoring operation using time settings and current values as shown on relay with 10% tolerance.

Time current curves, shown on page 8, can be approximated by using test arrangement shown on page 7.

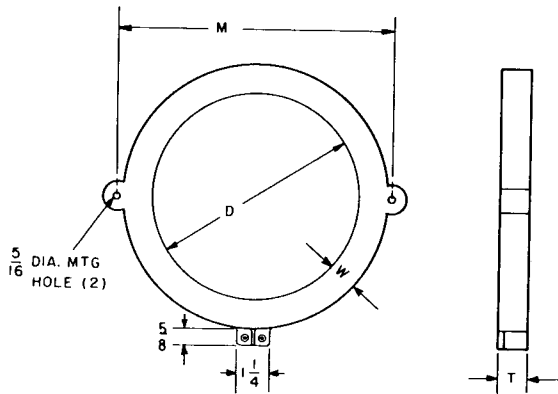

Catalog Number	D	M	W	T
302B0200	2-1/8	5-1/16	1-1/8	1-7/8
302B0300	3-1/8	6	1-1/8	1-7/8
302B0500	5	7-1/2	1	1
302B0800	8	10-3/4	1-1/8	1
302D0800	8	Split Sensor—Refer to Factory		

NOTE: Round cable spacers are provided with the 2 larger sensors to maintain clearances from sensor. Spacers add to outside dimension 1 inch (for D=5) or 2 to 3 inches (for D=8). Spacers reduce inside dimension (D) by 2 inches.

Figure 1 — Toroidal Ground Sensors — Outline

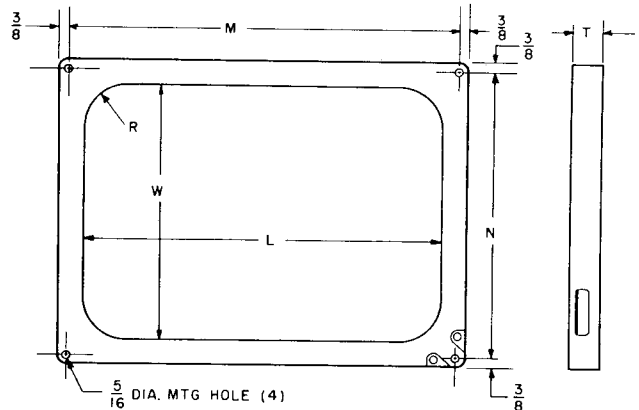

Catalog Number	Size	L	W	R	M	N	T
302B1013	10x13	13	10	1-3/4	14-3/4	11-3/4	1-1/2
302B1017	10x17	17	10	1-3/4	18-3/4	11-3/4	1-1/2
302B1024	10x24	24	10	1-3/4	25-3/4	11-3/4	1-5/8
302B1620	16x20	20	16	1-3/4	21-3/4	17-3/4	1-1/2

NOTE: Apply with minimum 1 1/2 inch clearance from sensor to conductors.

Figure 2 — Rectangular Ground Sensors — Outline

Surface Mounted Relay

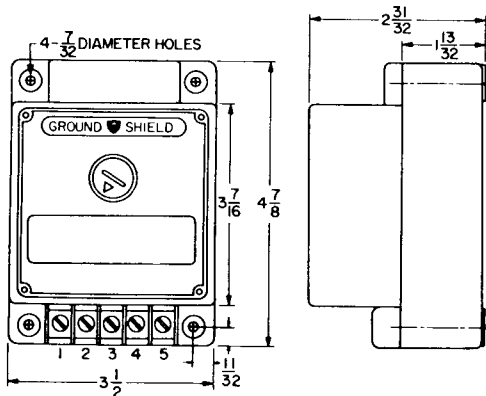

Figure 3 — Surface Mounted Relay—Outline and Drilling

Drawout Mounted Relay

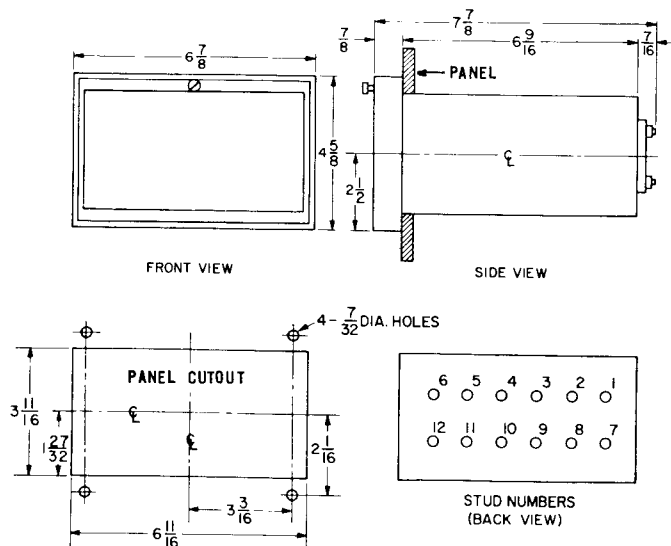

Figure 4 — Semi-Flush Mounted Relay—Outline and Drilling

NOTE: All dimensions are in inches.



PRECAUTIONS FOR INSTALLATION OF SPLIT SENSORS

1. Handle the disassembled halves with care to prevent dust or metallic particles from settling on the iron gaps. Gap surfaces should be perfectly CLEAN prior to re-assembly.
2. When mounting, make sure there is no mechanical stress imposed on either gap by LOOSELY bolting the sensor to the supports using locking type nuts which lock on the bolt threads.

3. Early design models had only one mounting hole in each half of sensor. Later designs have two mounting holes in each half so that sensor can be supported TIGHTLY by two bolts in ONE SENSOR HALF ONLY.
4. Cables should be spaced from sensor using the polyester SPACERS provided. Spacers may be omitted if cables are bundled (taped) together and bundle is kept 1/2" to 1" from sensor.

WIRING DIAGRAMS

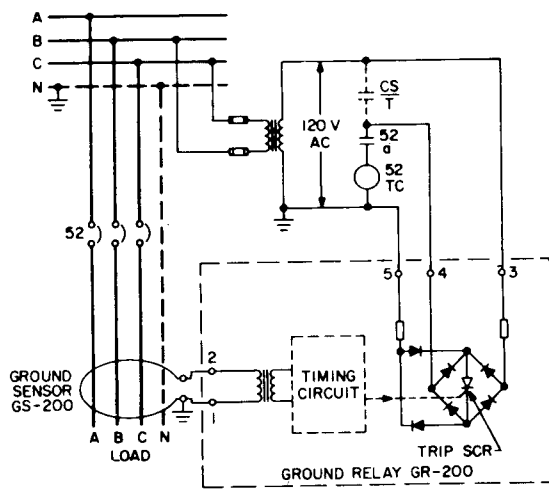

Figure 5 — Type GR-200 Surface Mounted Relay. 120 Vac Control Power.

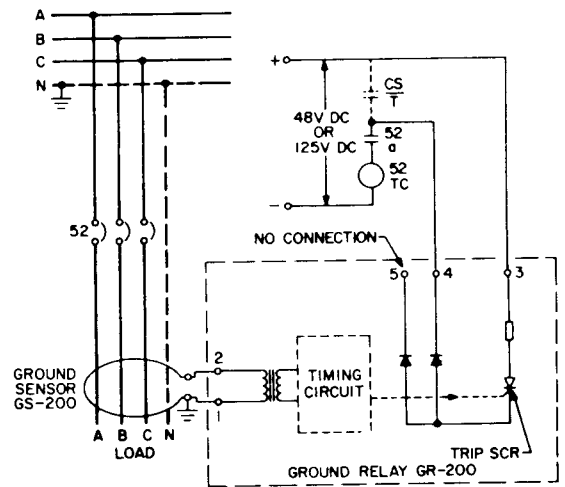

Figure 6 — Type GR-200 Surface Mounted Relay. 48 or 125 Vdc Control Power

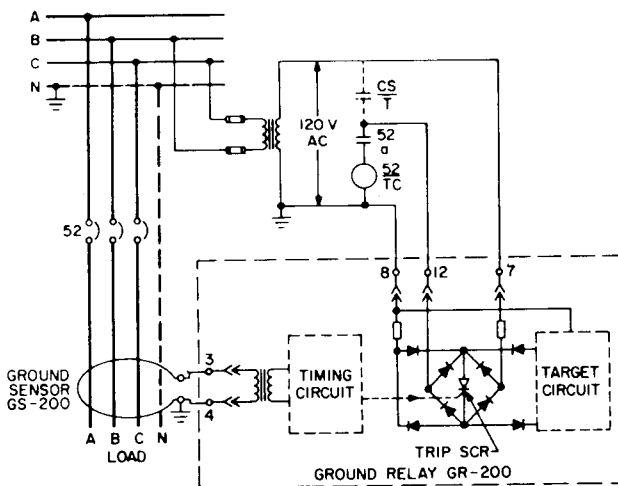

Figure 7 — Type GR-200 Semi-Flush Mounted Relay. 120 Vac Control Power.

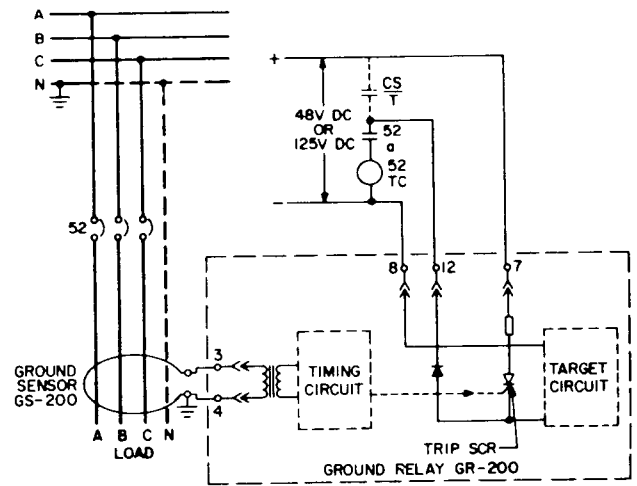

Figure 8 — Type GR-200 Semi-Flush Mounted Relay. 48V or 125 Vdc Control Power.



INPUT CIRCUIT DUTY RATINGS

	Amperes of Ground Fault Current
Momentary (2 Cycles)	80,000
Short Time (½ Second)	60,000
Continuous	3,000

OUTPUT CIRCUIT DUTY RATINGS

Nominal Voltage	Range	Max. Current, Amps RMS or AVG.		
		2 Cycles	1 Second	Continuous
125 Vdc	70-140	30	7.5	1
48 Vdc	28-60	30	7.5	1
120 Vac	50-130	30	7.5	—

OPERATION TEST CONNECTIONS (see page 3)

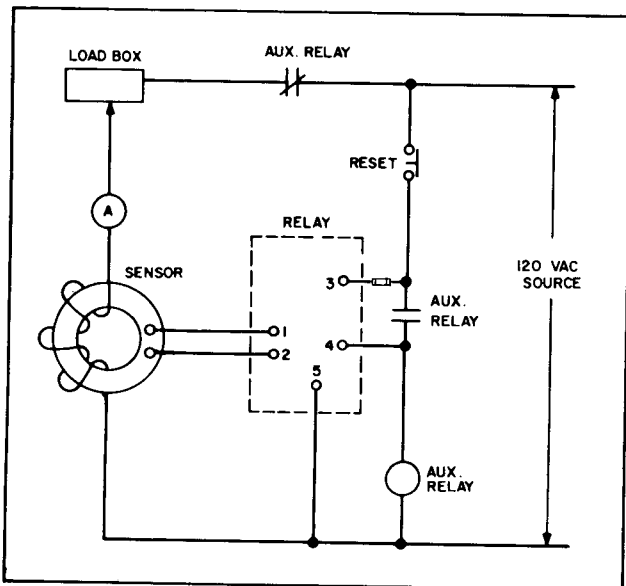

Figure 9 — 120 Vac Surface Mounted Relay

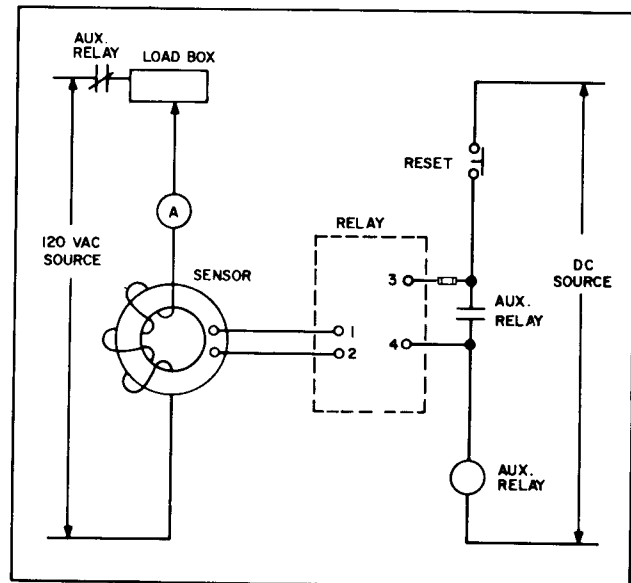

Figure 10 — 48V and 125 Vdc Surface Mounted Relay

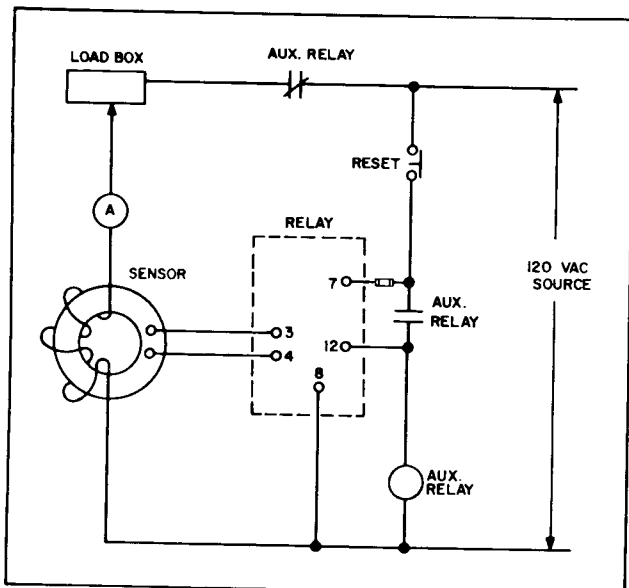

Figure 11 — 120 Vac Semi-Flush Mounted Relay

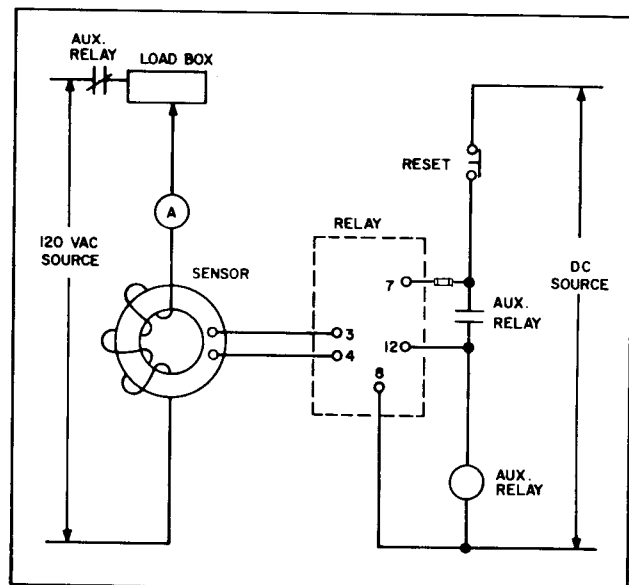

Figure 12 — 48V and 125 Vdc Semi-Flush Mounted Relay



**RELAY CALIBRATION TESTS USING SYNCHRONOUS TIMER**

Loop 20 turns of wire through sensor and apply 20 amperes.  
Set relay at 200 amperes pickup. Current is two (2) multiples of this pickup setting.

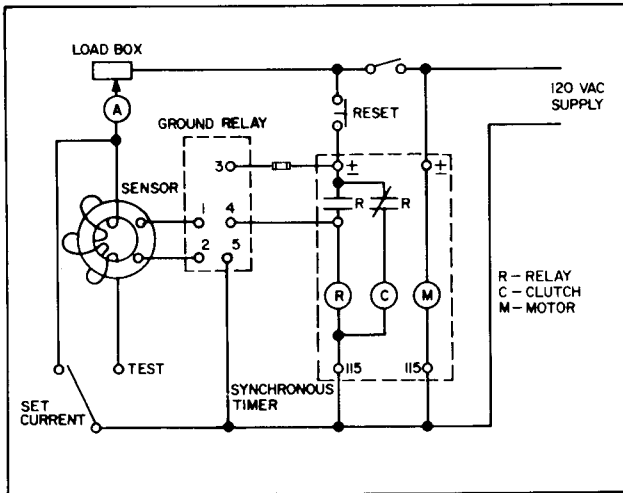

Figure 13 — Time Curve Test Circuit  
120 Vac Surface Mounted Relay

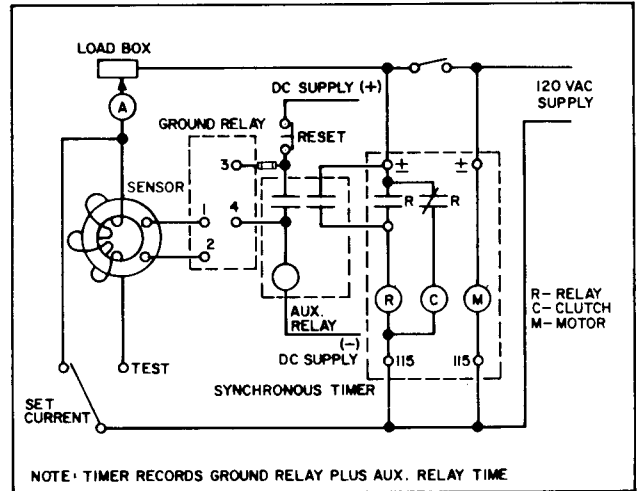

Figure 14 — Time Curve Test Circuit  
48 and 125 Vdc Surface Mounted Relay

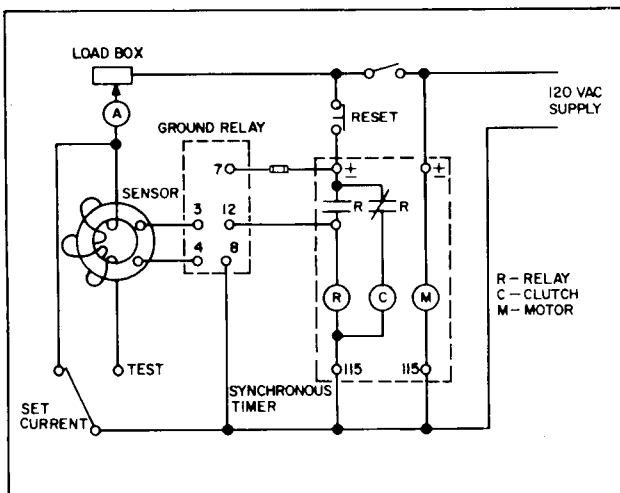

Figure 15 — Time Curve Test Circuit  
120 Vac Semi-Flush Mounted Drawout Relay

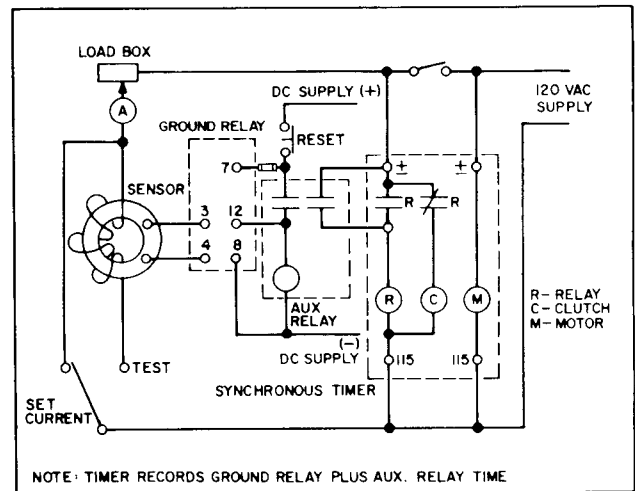
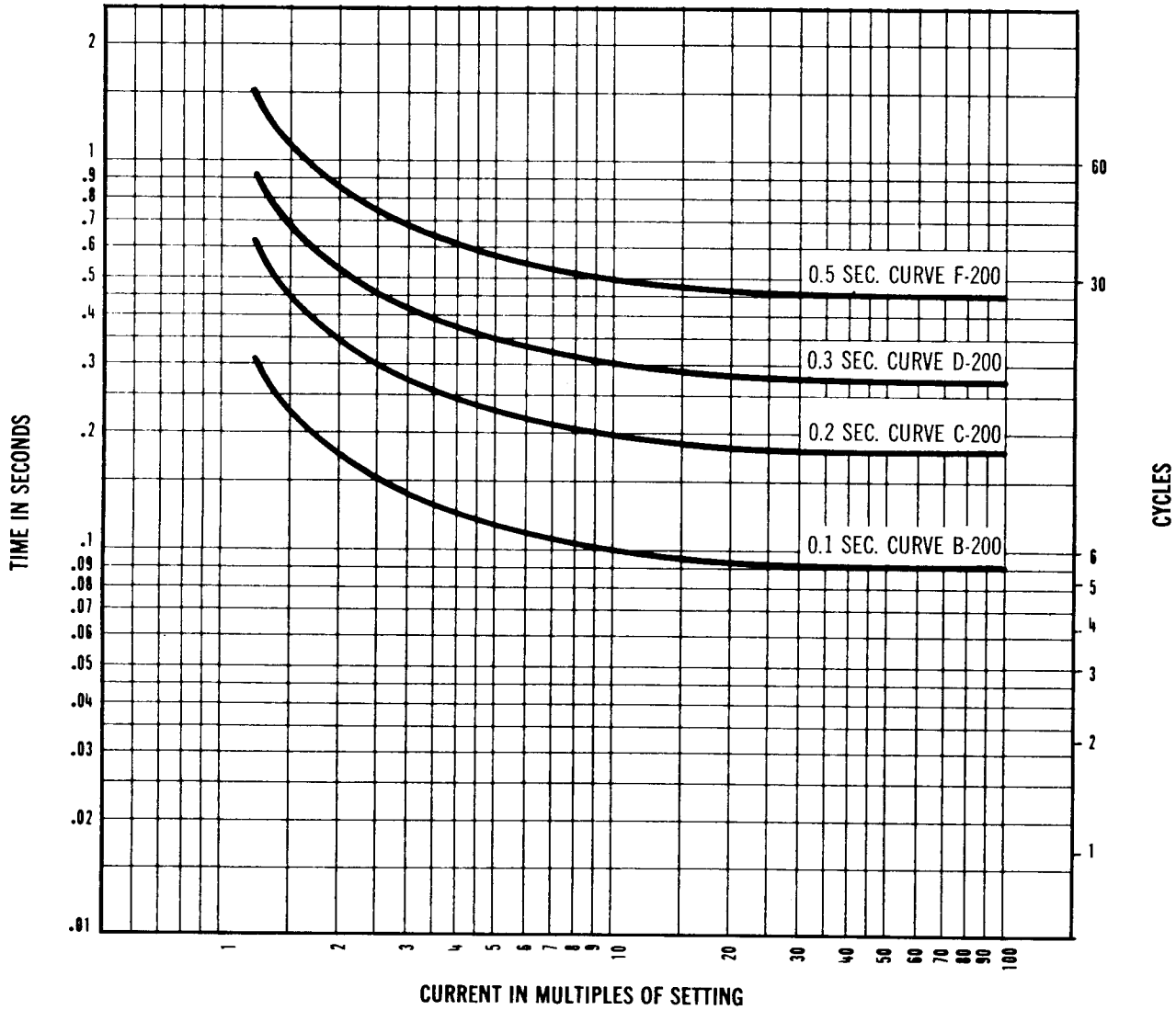

Figure 16 — Time Curve Test Circuit  
48 and 125 Vdc Semi-Flush Mtd. Drawout Relay



TIME-CURRENT CHARACTERISTICS



PICKUP SETTINGS—200, 300, 400, 600, 1000, 1600, 2000 AMPERES PRIMARY CURRENT

These instructions do not purport to cover all details or variations in equipment nor to provide for every possible contingency to be met in connection with installation, operation, or maintenance. Should further information be desired or should particular problems arise which are not covered sufficiently for the purchaser's purposes the matter should be referred to the I-T-E Imperial Corporation.



**ITE Imperial**  
CORPORATION