



SEL-221F/121F Distance Relay



DWG. NO. 1017-104
DATE: 01-07-92

SEL-221F and SEL-121F Phase and Ground Distance Relay, Directional Ground Relay, Synchronism Checking Relay, Reclosing Relay, Fault Locator

Data Sheet

- Three zones of phase and ground distance protection provide complete line coverage.
- Residual instantaneous and inverse-time overcurrent elements give sensitivity for high impedance ground faults.
- Negative-sequence element provides sensitive and secure directional polarization.
- Relay detects remote-end-opening for pilotless permissive tripping.
- Switch-onto-fault logic permits instantaneous tripping for reclosing or line pickup.
- Programmable Mask Logic provides application and testing flexibility.
- Load compensating fault locator reduces line patrolling for improved system reliability.
- Eleven-cycle event report simplifies fault and system analysis.
- Serial communications ports allow local or remote interaction with the relay.
- Available in 5.25" or 3.5" high chassis sizes.

SCHWEITZER ENGINEERING LABORATORIES
2350 NE Hopkins Court • Pullman, WA • 99163-5603 • USA
Phone: (509) 332-1890 • Fax: (509) 332-7990
E-mail: info@selinc.com • Internet: www.selinc.com



GENERAL DESCRIPTION

The SEL-221F and SEL-121F Relays are designed to protect transmission, subtransmission, and distribution lines for all fault types. The relays have identical protection features, but use different hardware designs. This data sheet describes both relays. The following list outlines protective features, performance, and versatility gained when applying either relay to your installations.

- Three zones of phase and ground distance protection
- Residual time-overcurrent element with selectable curves
- Instantaneous residual overcurrent element
- Negative-sequence polarization of ground directional elements
- Versatile user-programmable logic for outputs and tripping
- Programmable switch-onto-fault logic
- Loss-of-potential detection logic
- Programmable single-shot reclosing with synchronism check and voltage checking
- Fault locating
- Metering
- EIA-232 serial communications ports for local and remote access
- Automatic self-testing
- Target indicators for faults and testing

Three Zones of Phase and Ground Distance Protection

The relay has three zones of phase-to-phase and phase-to-ground mho distance elements with independent timers. Distance elements are polarized using positive-sequence memory voltage.

Without requiring an external initiating contact input, the relay provides time-stepped protection in parallel with communication-assisted protection. The relay supports Permissive Overreaching or Underreaching Transfer Trip (POTT or PUTT) schemes, Direct Underreaching Transfer Trip (DUTT) schemes, and Direct Transfer Trip (DTT) schemes.

Residual Overcurrent Elements

The relay includes an instantaneous directional ground overcurrent element. A ground time overcurrent element is available for sensitive ground fault detection. Four curve shapes are available and the time dial is settable in small increments to simplify coordination with downstream protective devices.

Negative-Sequence Directional Polarization

The relay has a sensitive negative-sequence directional polarization element to control the ground overcurrent elements and supervise the distance elements.

Switch-Onto-Fault Logic

Select sensitive elements to trip for a settable time after the breaker closes. End-of-line faults can be cleared with no time delay on reclose.

Programmable Mask Logic

The SEL-221F Relay has programmable mask logic. Configure the TRIP and auxiliary outputs to operate when any of 24 protective elements and logic outputs pick up. Implement complete protective schemes using a minimum of wiring and panel space. Programmable contact closure simplifies testing by indicating pickup and dropout of elements under test.

Eleven-Cycle Event Report

The relay generates an eleven-cycle event report after each fault, or upon command. The report provides four cycles of pre-fault data and seven cycles of fault data. The data includes voltages, currents, relay elements, and relay inputs and outputs. The report also shows the calculated fault location, time and date of event, and relay settings. This information simplifies post-fault analysis and improves understanding of protective scheme operation. The relay stores the last twelve event reports for local or remote retrieval. Reclosing sequences are stored intact and no information is lost when several events occur in a short time.

The relay has a fault locating algorithm that automatically compensates for pre-fault load flow and fault resistance. Accurate fault location reduces search and outage time; lower outage time means higher overall system reliability.

Serial Communications Ports

The relay is equipped with two serial communications ports to provide local or remote access to setting, metering, and fault analysis capability. Remote communications allow operators to retrieve fault information from a remote relay immediately, without leaving their stations. The SEL-221F Relay includes a front-panel connector for PORT 2. This provides convenient local connection to the relay, without removing cables from the relay rear panel.

A two-level password security scheme prevents unauthorized access to the relay. The first level allows examination of settings and power system data. Setting changes are made from the second level.

The relay requires no special communications software: you can use a dumb terminal, printing terminal, or computer with serial port and terminal emulation software.

The relay is compatible with the SEL-2020 and SEL-2030 Communications Processor, the SEL-DTA Display/Transducer Adapter, SEL-RD Relay Display, and the SEL-PROFILE[®] Transmission Line Fault Analysis Program.

GENERAL SPECIFICATIONS

<u>Voltage Inputs</u>	115 volt nominal phase-to-phase, three-phase four-wire connection Synchronism checking voltage: 0 - 120 V _{L-N} , single-phase voltage
<u>Current Inputs</u>	5 Amps per phase nominal; 15 Amps per phase continuous; 500 Amps for one-second thermal rating 60/50 Hz system frequency and ABC/ACB phase rotation are user-settable.
<u>Output Contact Current Ratings</u>	30 Amp make per <i>IEEE C37.90</i> , para 6.7.2 6 Amp carry continuously; MOV protection provided
<u>Optoisolated Input Ratings</u>	24 Vdc: 15 - 30 Vdc 48 Vdc: 30 - 60 Vdc 125 Vdc: 80 - 150 Vdc 250 Vdc: 150 - 300 Vdc
<u>Time-Code Input</u>	Relay accepts demodulated IRIG-B time-code input.
<u>Communications</u>	Two EIA-232 serial communications ports; SEL-221F Relay has a front-panel connector for PORT 2.
<u>Power Supply</u>	24/48 Volt: 20 - 60 Vdc; 12 watts 125/250 Volt: 85 - 350 Vdc or 85 - 264 Vac; 12 watts
<u>Dimensions</u>	3.5" x 19" x 10.5" (8.89 cm H x 48.2 cm W x 26.7 cm D) SEL-221F Relay 5.25" x 19" x 13" (13.3 cm H x 48.2 cm W x 33.0 cm D) SEL-121F Relay Available in horizontal or vertical mounting configurations.
<u>Dielectric Strength</u>	V, I inputs: 2500 Vac for 10 seconds Other: 3000 Vdc for 10 seconds (excludes EIA-232)
<u>Operating Temp.</u>	-40° to 158°C (-40° to 70°F).
<u>Environment</u>	<i>IEC 68-2-30</i> Temperature/Humidity Cycle Test - six day (type tested)
<u>Interference Tests</u>	<i>IEEE C37.90</i> SWC Test (type tested) <i>IEC 255-6</i> Interference Test (type tested)
<u>Impulse Tests</u>	<i>IEC 255-5</i> 0.5 joule 5000 volt test (type tested)
<u>RFI Tests</u>	Type-tested in field from a quarter-wave antenna driven by 20 watts at 150 MHz and 450 MHz randomly keyed on and off one meter from relay.
<u>ESD Test</u>	<i>IEC 801-2</i> Electrostatic Discharge Test (type tested)
<u>Weight</u>	21 lbs (9.5 kg); shipping weight 26 lbs (11.8 kg) SEL-121F 12 lbs (5.5 kg); shipping weight 17 lbs (7.7 kg) SEL-221F

FUNCTIONAL SPECIFICATIONS

Expanded Mho Characteristics for Phase-to-Ground, Phase-to-Phase, and Three-Phase Faults

- Three forward zones of phase and ground distance protection
- Distance elements polarized from positive-sequence memory voltage
- Polarization method provides distance element expansion for improved resistive fault coverage
- Independent timers for Zone 2 phase, Zone 2 ground, and Zone 3 distance elements (time-step backup protection)
- Fault detectors and negative-sequence directional elements supervise distance elements
- Loss-of-potential logic supervises all distance elements, when enabled

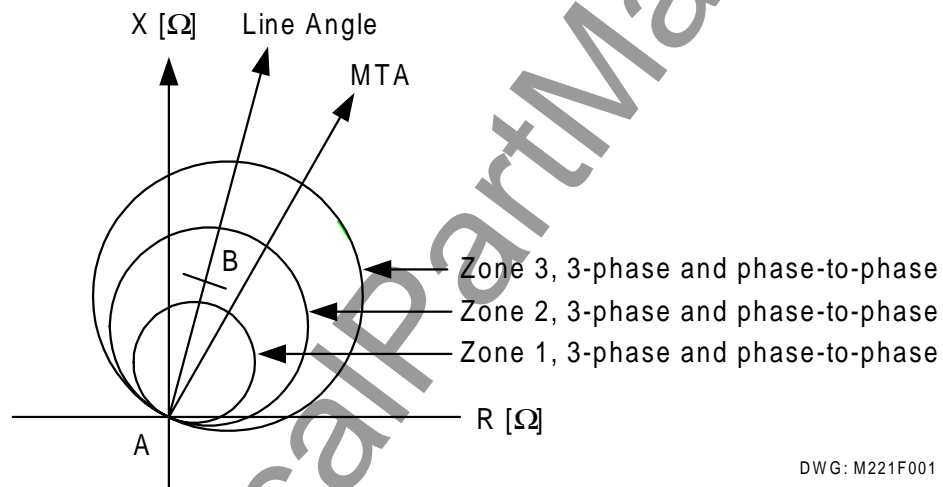

Figure 1: Three Zones of Phase and Ground Mho Distance Protection

Phase-to-Phase Distance Element Setting Ranges (Secondary Quantities)

21AB1, 21BC1, 21CA1: 0.125 to 64 ohms

21AB2, 21BC2, 21CA2: 0.125 to 64 ohms

21AB3, 21BC3, 21CA3: 0.125 to 64 ohms

Zone 1 < Zone 2 < Zone 3

Ground Distance Element Setting Ranges (Secondary Quantities)

21AG1, 21BG1, 21CG1: 0.125 to 64 ohms

21AG2, 21BG2, 21CG2: 0.125 to 64 ohms

21AG3, 21BG3, 21CG3: 0.125 to 64 ohms

Zone 1 < Zone 2 < Zone 3

Minimum Sensitivity

0.5 Amps secondary, defined by the fault detector minimum setting.

Maximum Torque Angle (MTA)

Adjustable from 47° - 90°. Residual Current Compensation (K) Factor Range

Magnitude limits: $0.0833 < |K| < 2.0$

Angle limits: $47^\circ < \text{MTA} + \angle K < 113^\circ$

Where: $K = \frac{Z_0 - Z_1}{3 \times Z_1}$

$Z_0 = R_0 + jX_0$

$Z_1 = R_1 + jX_1$

R0, X0, R1, X1 Relay Impedance Settings

Accuracy

Steady-state Error:

- $\pm 5\%$ of set reach ± 0.01 ohm at MTA for $V > 5$ V and $I > 2$ A.
- $\pm 10\%$ of set reach ± 0.01 ohm at MTA for $1 < V < 5$ V and $0.5 < I < 2$ A.

Transient Overreach:

- $\pm 5\%$ of set reach, plus steady-state error.

Operating Speed

See Figure 11 for operating time curves.

Memory Polarization

Phase and ground distance elements are positive-sequence memory voltage polarized from an infinite impulse-response filter with a four-cycle time constant, yielding polarization for at least six cycles.

Zone 2 and 3 Distance Element Timers

Zone 2 ground distance element timer (Z2DG) range: 3 - 2000 cycles in 1/4-cycle steps

Zone 2 phase distance element timer (Z2DP) range: 3 - 2000 cycles in 1/4-cycle steps

Zone 3 timer (Z3DP) range: 3 - 2000 cycles in 1/4-cycle steps

Note: The instantaneous and time-delayed outputs of the Zone 3 distance elements are separate in the Relay Word, permitting access to both. This allows use of a time delay for time-stepped backup functions while maintaining the required instantaneous outputs for communications-based protection schemes.

Distance Element Description and Characteristics

The phase and ground distance elements in the SEL-221F Relay are supervised by three relay elements or functions:

- A negative-sequence directional element.
- Nondirectional phase and ground overcurrent fault detecting elements.
- A loss-of-potential, if enabled.

The negative-sequence directional element operates when negative-sequence voltage and current indicate that the fault is in the forward direction. The element is sensitive and secure.

The phase distance elements are supervised by 50P nondirectional phase overcurrent elements.

Ground distance elements are supervised by single-phase 50G phase overcurrent elements and the 50N residual overcurrent element. Both elements are set using the 50NG relay setting, and both elements must pick up before the ground distance elements can give an output.

Loss-of-potential logic blocks distance element operation during blown potential fuse periods if you enable the function by setting LOPE = Y, N, 1, 2, 3, or 4.

The SEL-221F Relay uses positive-sequence memory voltage polarized mho distance elements for phase and ground distance protection. These elements expand in proportion to the source impedance to provide more resistive fault coverage than self-polarized mho elements.

When we use positive-sequence memory voltage polarization, the mho characteristics expand all the way back to the source. The relay impedance setting Z_r defines the maximum reach point. Figures 2, 3, and 4 show the impedance plane characteristics for several fault types. The forward-reaching mho circles extend from the source impedance Z_S , forward to the relay impedance setting Z_r .

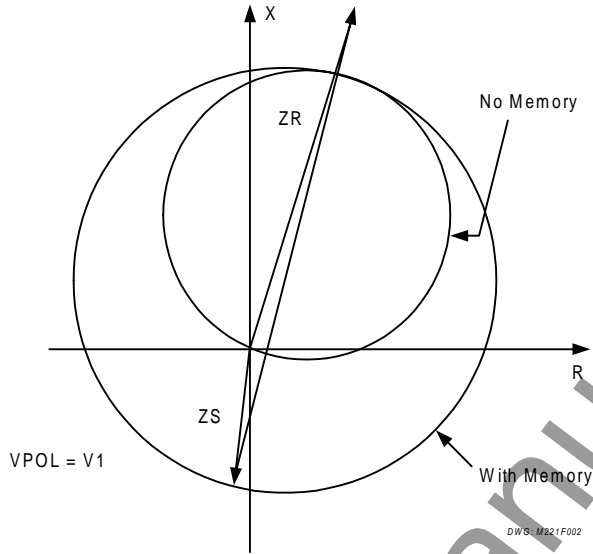

Figure 2: Phase-to-Phase Element Response for a Three-Phase Forward Fault

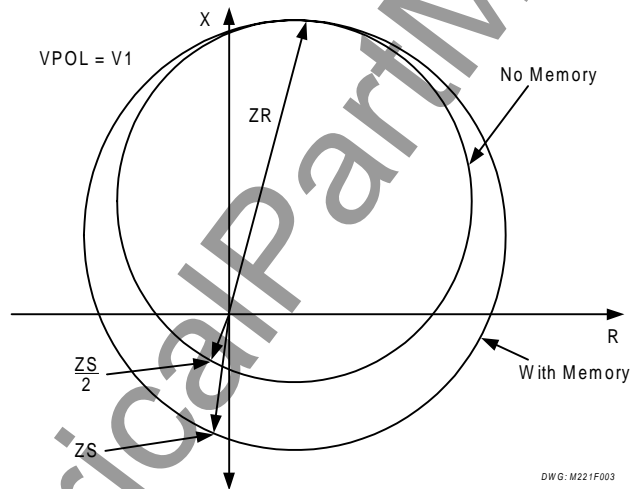

Figure 3: Phase-to-Phase Element Response for a Phase-to-Phase Forward Fault

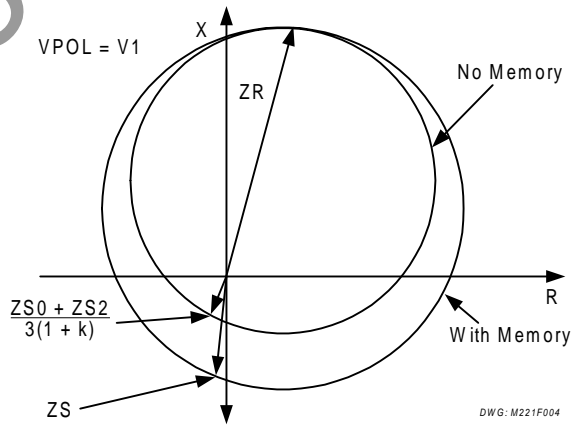

Figure 4: Phase-to-Ground Element Response for a Phase-to-Ground Forward Fault

Residual Overcurrent Backup Protection for Ground Faults

- Time-overcurrent element detects highly resistive ground faults
 - Four curve families (moderate, inverse, very inverse, and extremely inverse)
 - Nondirectional or forward-reaching, as enabled in relay settings
- Instantaneous residual overcurrent element
 - Nondirectional or forward-reaching, as enabled
- Negative-sequence polarized directional element

Ground Overcurrent Element Setting Ranges (Secondary Quantities)

- 50N residual overcurrent element
 - Nondirectional element supervises ground distance elements
 - Pickup: 0.5 A to 25 times 51N pickup, but less than 40 A
 - Transient overreach: $\pm 5\%$ of set pickup
- 51N residual time-overcurrent element
 - Selectable curve shape (four curve families)
 - Moderately Inverse (curve family 1)
 - Inverse (curve family 2)
 - Very Inverse (curve family 3)
 - Extremely Inverse (curve family 4)
 - Time dial: 0.50 to 15.00 in 0.01 steps
 - Pickup: 0.5 to 8.0 A, ± 0.05 A $\pm 3\%$ of setting
 - Timing: $\pm 4\%$ and ± 1 cycle for residual current magnitude between 2 and 20 multiples of pickup
 - May be directionally controlled (51NNTC setting)
- 67N residual overcurrent element
 - Pickup: 0.5 A to 50 times 51N pickup
 - Transient overreach: $\pm 5\%$ of set pickup
 - May be directionally controlled (67NNTC enables)

Negative-Sequence Directional Element

- Directional polarization is based upon negative-sequence voltage and current.
- Adds security to phase and ground distance elements.
- May polarize ground directional overcurrent protection, if enabled.
- The angle between the measured negative-sequence voltage and current adjusted by the MTA setting determines fault direction (See Figure 2.2 of the Instruction Manual)
- Angle: MTA setting.
- Sensitivity: $0.32 V_A (V_2 \times I_2)$ at MTA.

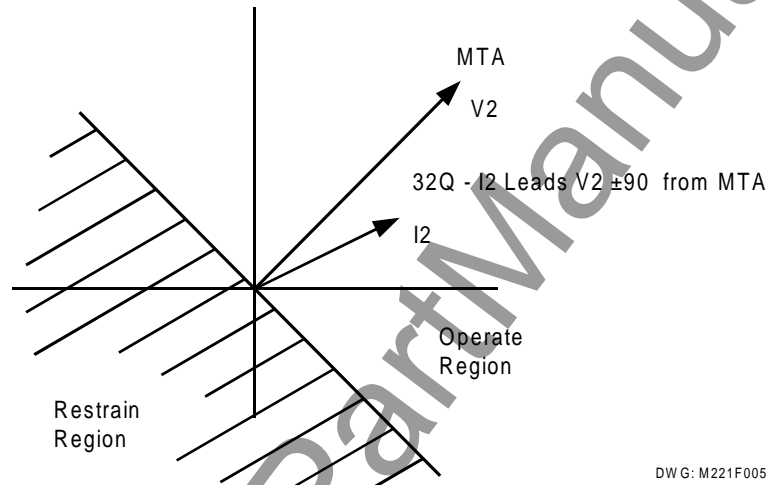

Figure 5: 32Q Polarization Criteria

Loss-of-Potential (LOP) Detection

- Detects blown secondary potential fuse(s) condition.
- Enabled or disabled with a simple setting.
- When enabled, an LOP condition blocks all mho distance elements.
- LOP detection may be selected to close programmable output relay or the ALARM contact for indication purposes.

Nondirectional Phase Overcurrent Elements

- Low-set phase overcurrent elements supervise phase distance elements and release the TRIP output contacts in conjunction with the low-set residual overcurrent element.
- Low-set phase overcurrent elements help detect blown potential fuses in LOP logic.
- Low-set three-phase overcurrent elements may be used in Remote-End-Just-Opened (REJO) logic to detect remote breaker clearance of in-section faults.
- High-set phase overcurrent element provides switch-onto-fault protection for close-in three-phase faults.

Nondirectional Phase Overcurrent Element Setting Ranges (Secondary Quantities)

- 50AG, 50BG, 50CG (low-set ground fault detectors)
Pickup: 0.5 A to 25 times 51NP, but less than 40 A, $\pm 0.1 \text{ A} \pm 2\%$ of setting
Transient overreach: $\pm 5\%$ of set pickup
- 50AP, 50BP, 50CP (phase fault detectors)
Pickup: 0.5 to 40 A, $\pm 0.1 \text{ A} \pm 2\%$ of setting
Transient overreach: $\pm 5\%$ of set pickup
- 50AH, 50BH, 50CH (high-set phase overcurrent elements)
Pickup: 0.5 to 80 A, $\pm 0.1 \text{ A} \pm 2\%$ of setting
Transient overreach: $\pm 5\%$ of set pickup

Remote-End-Just-Opened (REJO) Protection

- User-selected elements enabled to trip if remote breaker clears fault contribution.
- Provides pilotless accelerated tripping in many applications.

Switch-Onto-Fault Protection

- User-selected elements enabled to trip for 52BT time after the line breaker closes.
- Functions independently from communications channel equipment.

Reclosing

- Single reclosing shot with settable open interval timer.
- Selectable reclose initiate and cancel conditions.
- Settable reclose reset timer.
- Selectable voltage checking and synchronism checking can supervise reclosing.

Voltage Checking

- Closing may be supervised by Live-line/Dead-bus conditions, Live-bus/Dead-line conditions, or either condition.
- Supervision may be applied to closures initiated by external equipment.
- Supervision is independent of polarizing potential transformer location; you may use either supervision scheme with line-side or bus-side polarizing potentials.

Sequence-Component Elements (Secondary Quantities)

The following elements are used in the recloser supervision logic and loss-of-potential detection logic.

- Negative-sequence overvoltage element (47QL)
Pickup: $V_2 = 14 \text{ V}$ (fixed)

- Negative-sequence overcurrent element (46QL)
Pickup: $I_2 = 0.083 \text{ A}$ (fixed)
- Positive-sequence overvoltage element (59P)
Pickup: User-settable, $0 - 80 V_{1-n}$
- Positive-sequence undervoltage element (27P)
Pickup: User-settable, $0 - 80 V_{1-n}$
- VS input overvoltage element (59S)
Pickup: User-settable, $0 - 125 V_{1-n}$
- VS input undervoltage element (27S)
Pickup: User-settable, $0 - 125 V_{1-n}$

Synchronism Checking

- Closing may be supervised by a synchronism checking function.
- Supervision may be applied to closures initiated by external equipment.
- Relay setting allows synchronism check potential to be taken from any phase.

The synchronism checking voltage element determines the magnitude of the phasor difference between the positive-sequence voltage and the voltage applied to the VS input.

- Phasor difference voltage element (25DV)
Pickup: User-settable in volts primary, setting range limited $0 - 150 \text{ V}$ secondary

LOGIC INPUTS

The relay has six optoisolated inputs to sense external conditions: received permissive trip and block trip signals, breaker status, direct close, external event report trigger, and a programmable input. Assert an input by applying control voltage to the corresponding rear-panel input terminals.

OUTPUT CONTACTS

The relay has seven output contacts: TRIP, CLOSE, ALARM; and four programmable outputs: A1, A2, A3, and A4. The A1 contact includes settable time-delayed pickup and dropout timers. Any output contact except TRIP may be factory configured as either form a or form b.

RELAY WORD

The Relay Word consists of three rows of eight-bit groups that represent the state of the relay elements (both instantaneous and timed), timer and logic outputs, and relay inputs. Each bit in the Relay Word has two states: logical 1 when the element is asserted, logical 0 when the element is deasserted.

Each quarter-cycle, the relay samples voltage and current data, performs intermediate logic to determine if elements are asserted, and sets appropriate bits in the Relay Word.

Each TRIP, programmable output relay, and reclose initiate and cancel condition has a corresponding logic mask. These masks determine the state of the output relay and reclosing sequence, depending on which elements are asserted in the Relay Word.

Table 1 shows the SEL-221F Relay Word.

Table 1: Relay Word

Z1P	Z1G	Z2PT	Z2GT	Z3	Z3T	3P21	32Q
67N	51NP	51NT	50NG	50P	50H	IN1	REJO
LOP	52BT	27S	27P	59S	59P	SSC	VSC

The Relay Word Bit Summary Table explains each bit in the Relay Word.

Table 2: Relay Word Bit Summary

Z1P	Zone 1 phase fault, instantaneous output (set by Z1%)
Z1G	Zone 1 ground fault, instantaneous output (set by Z1%)
Z2PT	Zone 2 phase fault, time-delayed (set by Z2% and Z2DP)
Z2GT	Zone 2 ground fault, time-delayed (set by Z2% and Z2DG)
Z3	Zone 3 phase or ground fault, instantaneous output (set by Z3%)
Z3T	Zone 3 phase or ground fault, time-delayed (set by Z3% and Z3D)
3P21	Three-phase fault condition detected by phase distance relays
32Q	Negative-sequence directional element
67N	Residual instantaneous overcurrent (set by 67NP and 67NTC)
51NP	Pickup of residual time-O/C (set by 51NP and 51NTC)
51NT	Timeout of residual time-overcurrent element
50NG	Sensitive residual or phase overcurrent condition (set by 50NG)
50P	Phase overcurrent condition (set by 50P)
50H	High-set phase overcurrent condition (set by 50H)
IN1	Logic Input 1 (use for direct trip, reclose initiate/cancel, etc.)
REJO	Remote-end-just-opened condition
LOP	Loss-of-potential condition
52BT	Inverted 52A input, delayed by 52BT setting at pickup and dropout
27S	Synchronizing undervoltage condition (Tests VS against VLO setting)
27P	Polarizing undervoltage condition (Tests VP1* against VLO setting)

59S	Synchronizing overvoltage condition (Tests VS against VHI setting)
59P	Polarizing overvoltage condition (Tests VP1* against VHI setting)
SSC	Synchronization-supervised condition (set by 25DV, 25T, SYNCP)
VSC	Voltage-supervised condition (set by PSVC for disable/LSDP/LPDS/either)

*VP1 = Positive-sequence voltage applied to the polarizing voltage inputs.

PROGRAMMABLE OUTPUT LOGIC

The relay uses programmable logic masks to control the TRIP and programmable output relays. Logic masks are saved in nonvolatile memory with the other settings. They are set with the LOGIC command and retained through losses of control power.

To program each logic mask, select elements of the Relay Word. If any element in the Relay Word asserts and the same element is selected in a logic mask, the output contact associated with the logic mask closes.

The output equations follow:

Let R = Relay Word

MTU = mask for trip (unconditional)
MPT = mask for trip (permissive trip)
MTB = mask for trip (with no blocking)
MTO = mask for trip (with breaker just opened or closed)

Then:

TRIP = [R * MTU (unconditional tripping)
+ R * MPT * {PT + (REJO * REJOE = P OR G)} (permissive tripping)
+ R * MTB * NOT (BT) (tripping with BT input deasserted)
+ R * MTO * **52BT**] (breaker open/just closed tripping)
+ TC (Open Command Executed)

Close TRIP contact = TRIP

Open TRIP contact = NOT (TRIP) * [NOT (**50NG** + 46QL) + TARGET RESET button pushed] * (Minimum Trip Duration timer (TDUR) expired)

Close CLOSE contact = (DC + [Reclose Operation] + CLOSE COMMAND) * NOT (52A) * NOT (TRIP)

Open CLOSE contact = NOT (CLOSE) + 79RS + TRIP

A1 = R * MA1

A2 = R * MA2

A3 = R * MA3

A4 = R * MA4

The “*” indicates a logical “and,” while the “+” indicates a logical “or.”

RELAY TARGETS

The relay normally displays the targets identified on the front panel. Under normal operating conditions, the enable (EN) target lamp is lit. If the relay trips, it illuminates the LED corresponding to the element asserted at the time of trip. The target LEDs latch. The target LEDs that illuminated during the last trip remain lit until one of the following occurs:

- Next trip occurs.
- Operator presses the front-panel TARGET RESET button.
- Operator executes TARGET R command.

When a new trip occurs, the targets clear and the LEDs display the most recent tripping target.

When you press the TARGET RESET button, all eight indicators illuminate for a one-second lamp test. The relay targets clear and the enable light (EN) illuminates to indicate that the relay is operational.

Use the TARGET command and display to examine the state of the relay inputs, outputs, and the elements of the Relay Word.

Figure 6 shows the front-panel targets.

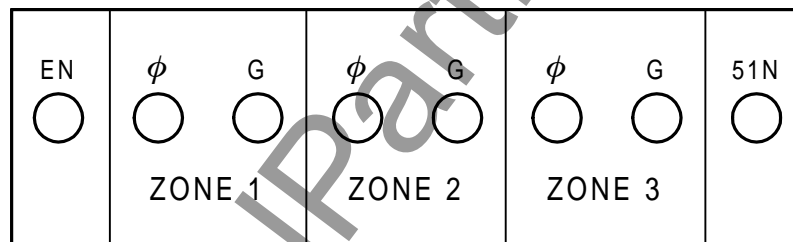

DWG: M221F006

Figure 6: Relay Targets

SERIAL INTERFACES

The SEL-221F Relay is equipped with two EIA-232 serial communications ports. PORT 2 has 9-pin connectors on both the front and rear panels, designated PORT 2F and PORT 2R, respectively.

PORT 2R, located on the relay rear panel, is typically used with an SEL-DTA display/transducer adapter, SEL-RD relay display, or local printer. PORT 2F is always available for short-term local communications with a portable computer or printing terminal. Simply plug the device into the front-panel port. The relay automatically discontinues communications with PORT 2R and addresses PORT 2F. When testing or data retrieval is complete, unplug the temporary device from PORT 2F. The relay automatically resumes communications with the device connected to PORT 2R.

Serial communications PORT 1 and the Auxiliary Input for demodulated IRIG-B time-code input remain on the relay rear panel.

The SEL-121F Relay is equipped with two EIA-232 serial communications ports. PORT 1 and PORT 2 have connectors located on the relay rear panel. The SEL-121F Relay does not include a front-panel connector for PORT 2.

Communications port baud rate jumpers are located along the front edge of the circuit board. To select a baud rate for PORT 1 or PORT 2, remove the relay front panel. The jumpers are visible near the center of the relay drawout assembly, to the right of the target LEDs. Carefully move the jumpers using needle-nosed pliers.

The serial data format is eight data bits, no parity. You can order the relay with software configured to use one stop bit or two stop bits. Communications use XON/XOFF flow control.

EVENT REPORTING

The relay retains a data record for each of the last twelve events. The record includes fault location, input voltages and currents, relay elements, input contacts, and output contacts. The relay saves a report when any of the following occur:

- The relay trips.
- Selected relay elements assert.
- User executes the TRIGGER or OPEN commands.
- IN1 (Programmable) or ET (External Trigger) input is asserted.

A sample event report is included near the end of this data sheet.

FAULT LOCATION

The relay computes fault location from event report data stored for each fault or disturbance. The relay uses two fault locating methods: the Takagi method where sound pre-fault data are available, or simple reactance method when sound pre-fault data are not available. The Takagi fault locating algorithm compensates for pre-fault load current to improve fault locating accuracy under load and for high-resistance faults.

METERING

The meter function shows the line-to-neutral and line-to-line ac voltage and current values, synchronism checking voltage input and residual current values, megawatts (P to represent real power), and megavars (Q to represent reactive power) in primary values. You can display these values locally or remotely with the METER command.

SELF-TESTING

The relay runs a variety of self-tests. Some tests have warning and failure states; others only have failure states. The relay generates a status report after any self-test warning or failure.

The relay closes the ALARM contact after any self-test fails. When the relay detects certain failures, it disables the breaker control functions and places the output relay driver port in an input mode. No outputs may be asserted when the relay is in this configuration.

Table 3 shows a list of the self-tests performed by the relay.

Table 3: Relay Self-Tests

Test	Description
Offset	Measures dc offset of analog input channels.
Power Supply	Measures internal power supply voltages.
Random-Access Memory	Verifies RAM operation.
Read-Only Memory	Verifies ROM operation.
Analog-to-Digital Converter	Verifies A/D operation.
Master Offset	Measures dc offset of multiplexer channel.
Settings	Verifies checksum of setting group.

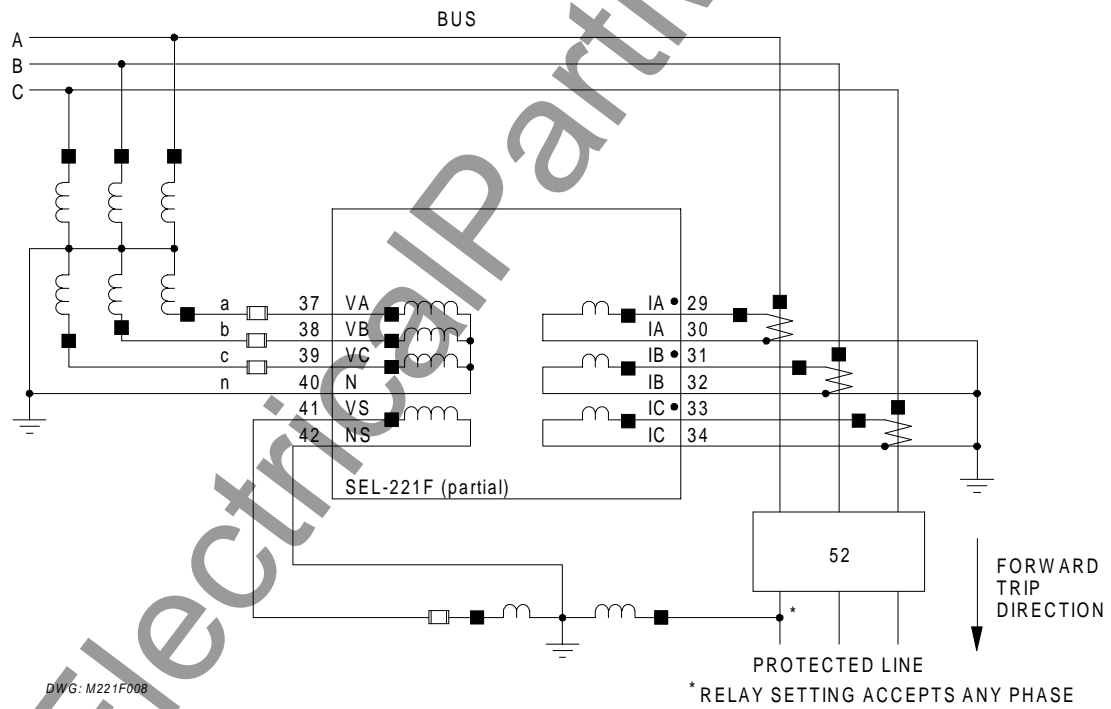
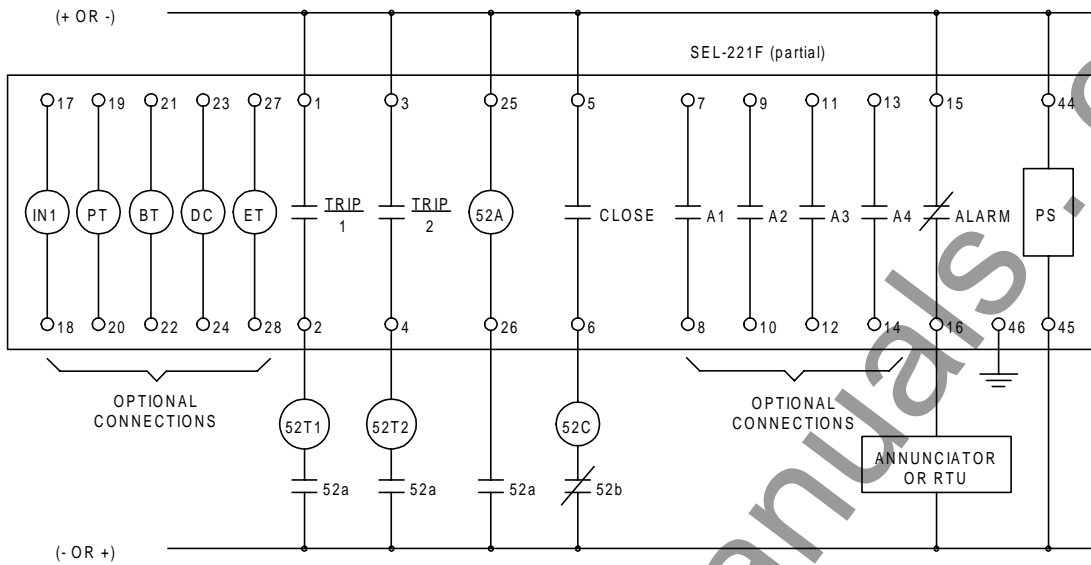
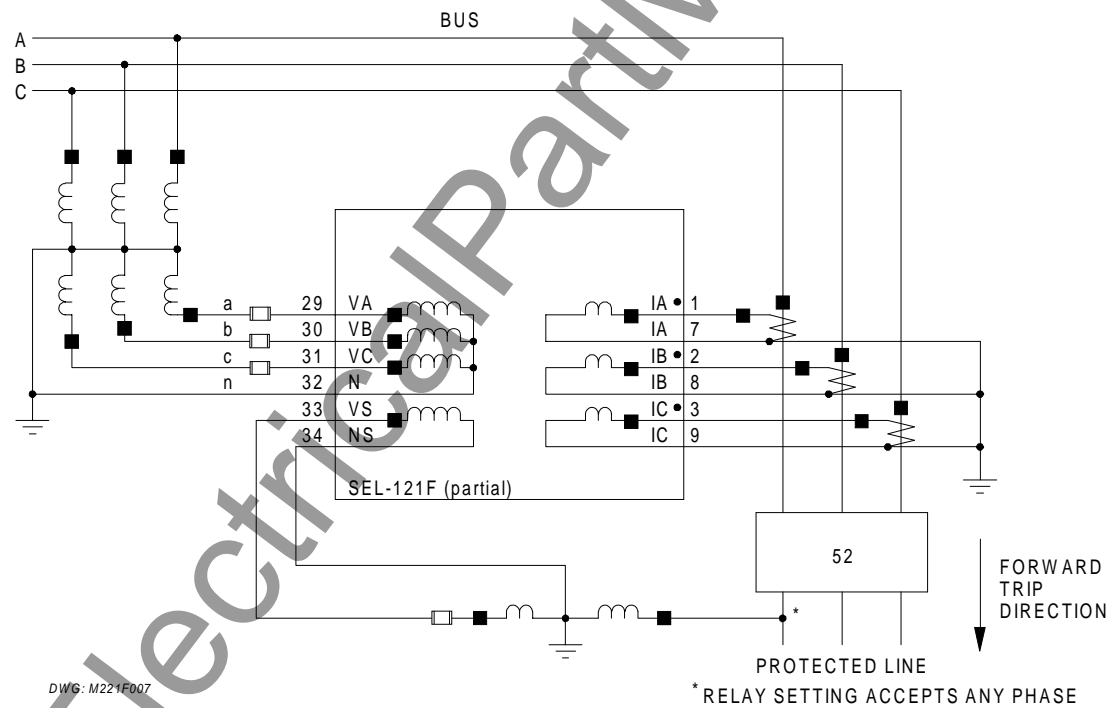

Figure 7: SEL-221F Relay Typical AC Current and Voltage Connections



DWG: M221F009

Figure 8: SEL-221F Relay Typical DC Connections



DWG: M221F007

Figure 9: SEL-121F Relay Typical AC Current and Voltage Connections

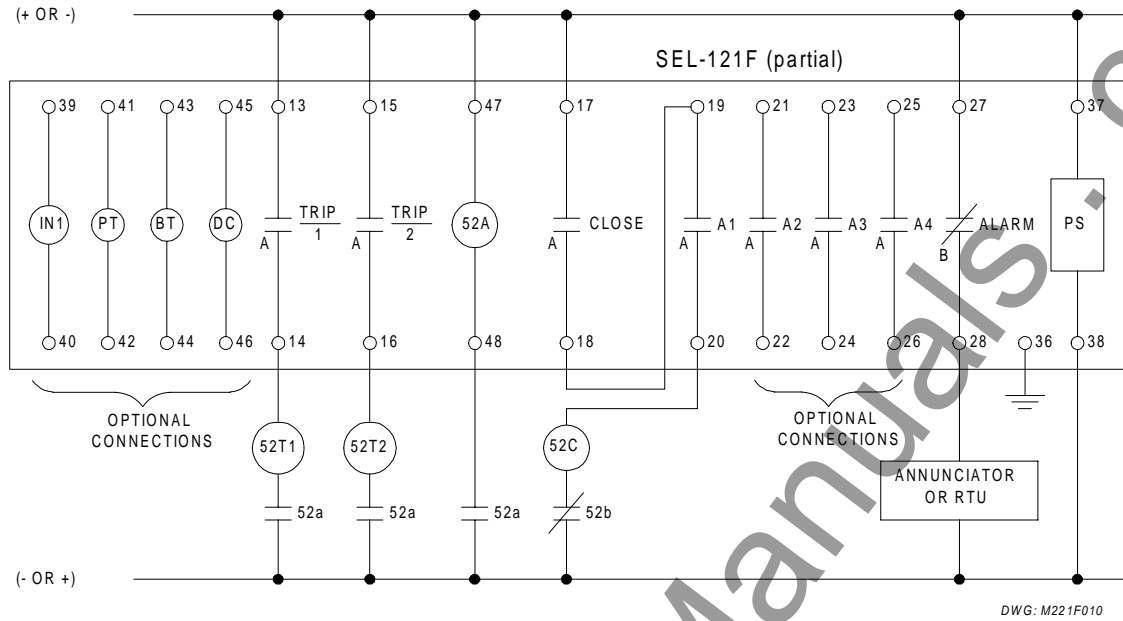
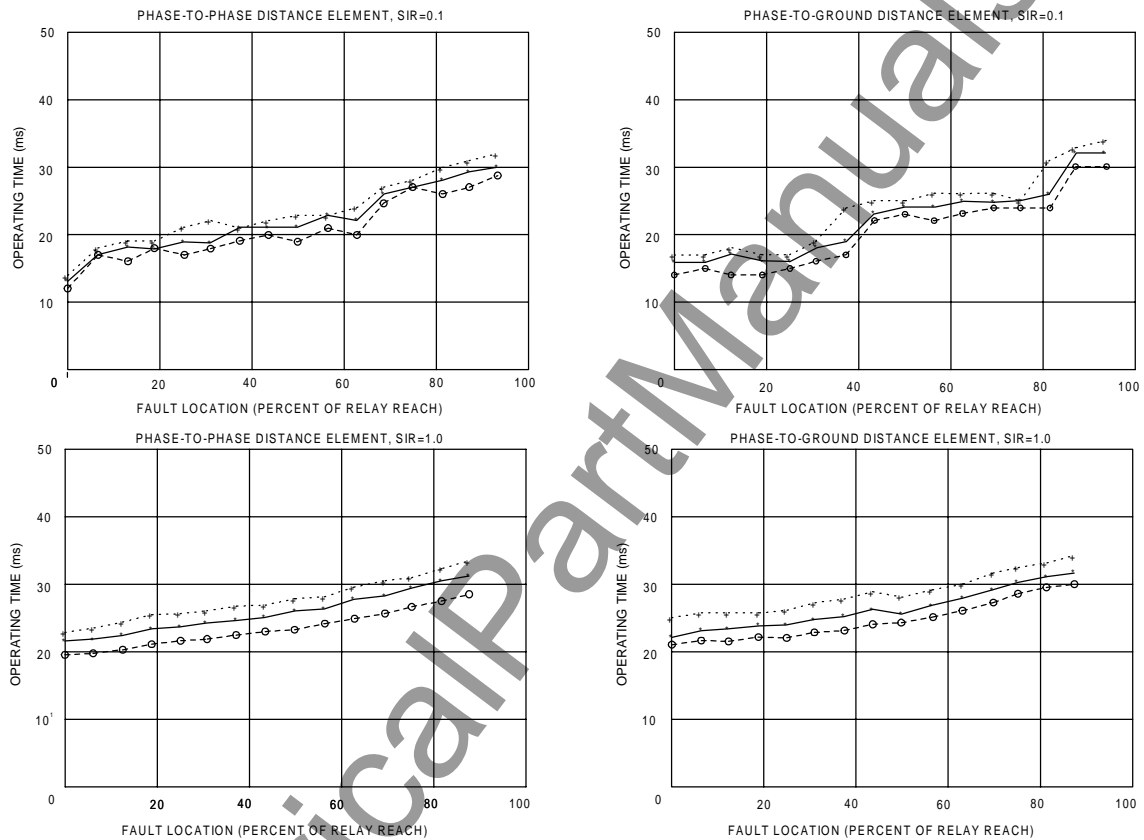

Figure 10: SEL-121F Relay Typical DC Connections

RELAY ELEMENT OPERATING TIME CURVES

Figure 11 shows operating times for the relay phase and ground distance elements. For the distance element tests, a fault was applied at a location representing a percentage of the Zone 1 relay reach setting. At each reach percentage five tests were run. Tests were performed for source impedance ratios (SIR) of 0.1 and 1.0. The diagrams show maximum, average, and minimum operating times at each test point. Operating times include output contact closure time. No pre-fault load current was included. System frequency is 60 Hz.



DWG. 1068-101
DATE: 08-11-92
REV. 0

Figure 11: Phase and Ground Distance Element Speed Curves

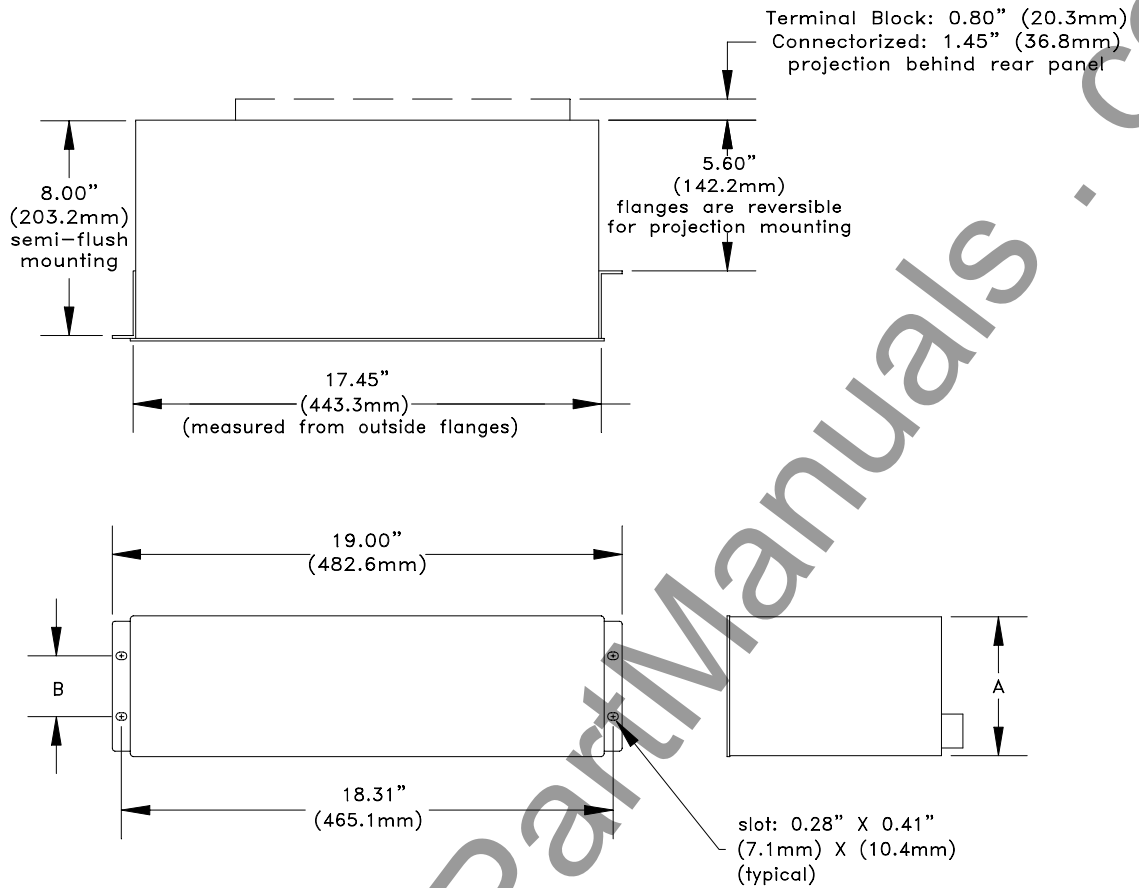

DIMENSION	MAIN BOARD ONLY (2U)	ONE I/O BOARD (3U)	TWO I/O BOARD (4U)
A	3.47" (88.1mm)	5.22" (132.6mm)	6.97" (177.0mm)
B	3.00" (76.2mm) 1.75" (44.5mm) optional	2.25" (57.2mm)	4.00" (101.6mm)

NOTE:

1. ALL TOLERANCES ARE ± 0.020 " (0.51mm)
2. TO DETERMINE THE CUTOUT DIMENSIONS CONSIDER BOTH SEL'S SPECIFIED TOLERANCE AND THE CUSTOMER'S ALLOWED TOLERANCE.
3. DRAWING NOT TO SCALE

DWG. I1367-Drill
DATE: 12 AUG 98

Figure 12: SEL-221F Relay Dimensions and Drill Plan

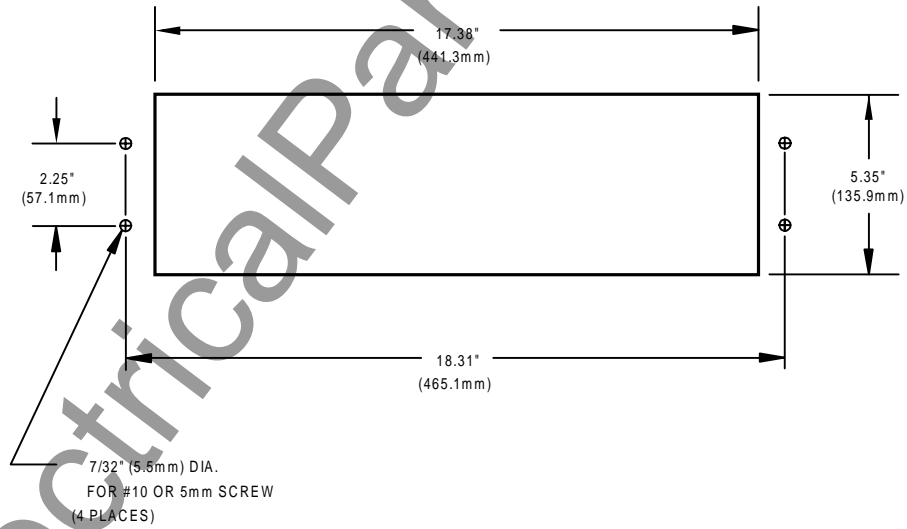
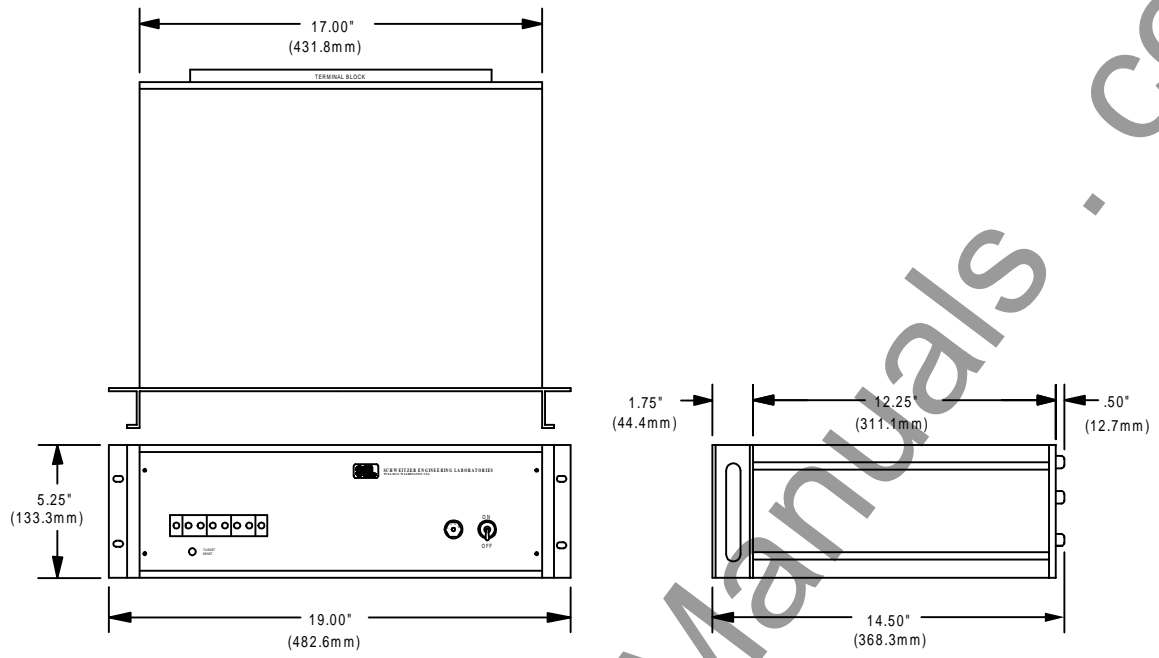

NOTE: ALL INSTRUMENTS MAY BE MOUNTED HORIZONTALLY (AS SHOWN) OR VERTICALLY

DWG. NO. 1086-102
 DATE: 02-12-93
 DATE: 05-21-93 REV. 1
 DATE: 06-30-93 REV. 2

Figure 13: SEL-121F Relay Dimensions, Panel Cutout, and Drill Plan

Example Event Report

Example 230 kV Line

Date: 11/10/92

Time: 10:48:46.579

Time-tag corresponds to the 16th quarter-cycle of this event report.

FID=SEL-121F-R405-V656mps2-D910326-E2

Currents (amps)			Voltages (kV)			Relays	Sync	Outputs	Inputs
IA	IB	IC	VA	VB	VC	VS			
							225556	22SV LR	TCAAAAA IPBD5E
							110107	77SS OE	PL1234L NTTC2T
							PGPNNN	SPCC PJ	1 A
							G	0	
-38	98	-60	-55.5	132.7	-77.1	-55.55.
-94	13	79	-121.3	12.5	108.0	-121.35.
38	-98	60	55.5	-132.7	77.1	55.55.
94	-9	-79	121.3	-12.5	-108.0	121.35.
-38	98	-60	-55.5	132.7	-77.2	-55.55.
-94	9	79	-121.4	12.4	108.2	-121.45.
38	-94	60	55.5	-132.7	77.1	55.55.
94	-13	-79	121.4	-12.4	-108.2	121.45.
-38	94	-60	-55.5	132.7	-77.1	-55.55.
-94	13	79	-121.4	12.4	108.2	-121.45.
38	-98	60	55.5	-132.7	77.1	55.55.
94	-9	-79	120.6	-12.7	-108.5	120.65.
35	98	-60	-54.1	133.4	-76.5	-54.15.
-116	9	79	-102.0	20.3	116.1	-102.05.
-277	-94	60	41.5	-138.5	71.3	41.55.
236	-13	-79	74.1	-31.8	-127.5	74.15.
485	94	-57	-29.3	143.6	-66.2	-29.35.
-346	13	76	-62.6	36.6	132.4	-62.65.
-529	-94	60	28.0	-144.3	65.5	28.05.
362	-13	-79	60.9	-37.3	-132.9	60.95.
535	94	-63	-27.9	144.4	-65.4	-27.95.
-365	13	82	-60.7	37.3	132.9	-60.75.
-535	-98	60	27.8	-144.4	65.5	27.85.
365	-9	-79	60.7	-37.2	-133.0	60.75.
535	98	-60	-27.8	144.4	-65.5	-27.85.
-365	9	76	-60.7	37.2	133.1	-60.75.
-535	-98	63	27.8	-144.4	65.4	27.85.
365	-9	-76	60.7	-37.2	-133.1	60.75.
535	98	-63	-27.9	144.4	-65.4	-27.95.
-365	9	76	-60.6	37.2	133.1	-60.65.
-535	-94	66	27.9	-144.4	65.4	27.95.
365	-13	-79	60.6	-37.3	-133.1	60.65.
535	94	-66	-27.9	144.4	-65.2	-27.95.
-365	13	79	-60.7	37.2	133.1	-60.75.
-535	-94	63	27.9	-144.4	65.2	27.95.
365	-13	-76	60.0	-33.3	-134.9	60.05.
462	82	-53	-26.4	124.1	-49.4	-26.45.
-318	3	63	-41.3	11.0	105.0	-41.35.
-233	-41	25	14.0	-59.9	20.7	27.95.
151	3	-28	13.2	3.9	-41.5	74.15.
44	6	-3	-1.6	9.0	-4.6	-55.55.
-16	0	3	-1.7	-0.4	5.5	-121.35.
-9	0	0	0.2	-1.1	0.8	55.55.
0	0	0	0.2	-0.1	-0.6	121.35.

One cycle of data

52A input is energized to indicate breaker is closed

50NG overcurrent element picks up

Ground fault enters Zone 3

Ground fault enters Zone 1, relay trips

A3 output closed to indicate Zone 1 ground fault

52A input is deenergized to indicate breaker opening

Protective elements dropout after breaker interrupts fault current

Event : 1AG Location : 75.86 mi 6.16 ohms sec
Duration: 6.25 Flt Current: 647.5

└─Event Summary

R1 =13.90 X1 =79.96 R0 =41.50 X0 =248.57 LL =100.00
CTR =200.00 PTR =2000.00 SPTR =2000.00 MTA =80.10
790I =40.00 79RS =240.00
PSVC =S 27VLO=26.60 59VHI=106.20 25DV =53.12 SYNCP=A
25T =300.00 VCT =30.00
A1TP =0.00 A1TD =0.00
Z1% =80.00 Z2% =120.00 Z3% =150.00
Z2DP =30.00 Z2DG =30.00 Z3D =40.00 TDUR =9.00
50NG =250.00 50P =370.00 50H =1500.00
51NP =270.00 51NTD=3.00 51NC =2 51NTC=Y
67NP =650.00 67NTC=Y 52BT =30 REJOE=N LOPE =Y
TIME1=5 TIME2=0 AUTO =2 RINGS=7

└─Relay Settings

Logic settings:

MTU	MPT	MTB	MTO	MA1	MA2	MA3	MA4	MRI	MRC
F4	04	00	FC	00	00	F0	04	F0	04
A2	00	00	A4	00	00	80	20	80	20
00	00	00	00	02	01	00	00	00	00

SEL-221F RELAY COMMAND SUMMARY

Access Level 0

ACCESS Answer password prompt (if password protection enabled) to gain access to Level 1. Three unsuccessful attempts pulses ALARM relay.

Access Level 1

2ACCESS Answer password prompt (if password protection enabled) to gain access to Level 2. This command always pulses the ALARM relay.

DATE m/d/y Show or set date. DAT 2/3/91 sets date to Feb. 3, 1991. This setting is overridden when IRIG-B synchronization occurs. Pulses the ALARM relay momentarily when a different year is entered than the previously stored.

EVENT Show event record. EVE 1 shows long form of most-recent event.

HISTORY Show DATE, TIME, EVENT TYPE, FAULT LOCATION, DURATION, and CURRENT for the twelve latest events.

IRIG Force immediate execution of time code synchronization task.

METER n Show primary current, voltage, and real and reactive power. METER runs once. METER n runs n times.

QUIT Return to Access Level 0 and reset targets to target 0.

SHOWSET Show the relay settings and logic settings – does not affect the settings. The logic settings are shown in hexadecimal format for each.

STATUS Show self-test status.

TARGET n Show data and set target lights as follows:

TAR 0: Relay Targets	TAR 1: RELAY WORD #1
TAR 2: RELAY WORD #2	TAR 3: RELAY WORD #3
TAR 4: INTERNAL ELEMENTS	TAR 5: Contact Inputs
TAR 6: Contact Outputs	TAR R: Returns to TAR 0 and clears

Be sure to return to TAR 0 when done, so LEDs display fault targets.

TIME h/m/s Show or set time. TIM 13/32/00 sets clock to 13:32:00 PM. This setting is overridden when IRIG-B synchronization occurs.

TRIGGER Trigger and save an event record. (Type of event is EXT).

Access Level 2

CLOSE	Close circuit breaker, if Jumper JMP104 is installed.
LOGIC n	Show or set logic masks MTU, MPT, MTO, MTB, MRI, MRC, MA1 - MA4. ALARM relay closes momentarily while the new settings are stored in EEPROM and event data buffers are cleared.
OPEN	Open circuit breaker, if Jumper JMP104 is installed.
PASSWORD	Show or set passwords. Pulses the ALARM relay momentarily when new passwords are set. PAS 1 OTTER sets Level 1 password to OTTER. PAS 2 TAIL sets Level 2 password to TAIL.
SET	Initiate setting procedure. ALARM relay closes momentarily while the new settings are stored in EEPROM and event data buffers are cleared.

Use the following to separate commands and their parameters: space, comma, semicolon, colon, or slash.

(This page intentionally left blank.)

FACTORY ASSISTANCE

The employee-owners of Schweitzer Engineering Laboratories are dedicated to making electric power safer, more reliable, and more economical.

We appreciate your interest in SEL products, and we are committed to making sure you are satisfied. If you have any questions, please contact us at:

Schweitzer Engineering Laboratories
2350 NE Hopkins Court
Pullman, WA USA 99163-5603
Tel: (509) 332-1890
Fax: (509) 332-7990

We guarantee prompt, courteous, and professional service.

We appreciate receiving any comments and suggestions about new products or product improvements that would help us make your job easier.

All brand or product names appearing in this document are the trademark or registered trademark of their respective holders.

Schweitzer Engineering Laboratories, SELoGic, Connectorized, and **SEL** are registered trademarks of Schweitzer Engineering Laboratories.

This product is covered by U.S. Patent Nos: 5,140,492; 5,479,315. Foreign Patents issued and other U.S. and Foreign Patents Pending.

Copyright © SEL 1990, 1991, 1992, 2000 (All rights reserved) Printed in USA.

SEL-221F/121F Distance Relay Data Sheet

Date Code 20000104



SCHWEITZER ENGINEERING LABORATORIES

2350 NE Hopkins Court • Pullman, WA 99163-5603 USA

Phone: (509) 332-1890 • Fax: (509) 332-7990

Internet: www.selinc.com • E-mail: info@selinc.com