

SIEMENS

SIPROTEC

Multi-functional Protective
Relay with Bay Controller
7SJ61

V4.7

Manual

Preface

Contents

Introduction

1

Functions

2

Mounting and Commissioning

3

Technical Data

4

Appendix

A

Literature

Glossary

Index

C53000-G1140-C210-1



Note

For safety purposes, please note instructions and warnings in the Preface.

Disclaimer of Liability

We have checked the contents of this manual against the hardware and software described. However, deviations from the description cannot be completely ruled out, so that no liability can be accepted for any errors or omissions contained in the information given.

The information given in this document is reviewed regularly and any necessary corrections will be included in subsequent editions. We appreciate any suggested improvements.

We reserve the right to make technical improvements without notice.

Document version V04.00.02

Release date 02.2008

Copyright

Copyright © Siemens AG 2008. All rights reserved.

Dissemination or reproduction of this document, or evaluation and communication of its contents, is not authorized except where expressly permitted. Violations are liable for damages. All rights reserved, particularly for the purposes of patent application or trademark registration.

Registered Trademarks

SIPROTEC, SINAUT, SICAM and DIGSI are registered trademarks of Siemens AG. Other designations in this manual might be trademarks whose use by third parties for their own purposes would infringe the rights of the owner.

Preface

Purpose of this Manual

This manual describes the functions, operation, installation, and commissioning of devices 7SJ61. In particular, one will find:

- Information regarding the configuration of the scope of the device and a description of the device functions and settings → Chapter 2;
- Instructions for Installation and Commissioning → Chapter 3;
- Compilation of the Technical Data → Chapter 4;
- As well as a compilation of the most significant data for advanced users → Appendix A.

General information with regard to design, configuration, and operation of SIPROTEC 4 devices are set out in the SIPROTEC 4 System Description /1/.

Target Audience

Protection engineers, commissioning engineers, personnel concerned with adjustment, checking, and service of selective protective equipment, automatic and control facilities, and personnel of electrical facilities and power plants.

Applicability of this Manual

This manual applies to: SIPROTEC 4 Multi-functional Protective Relay with Bay Controller 7SJ61; firmware version V4.7.

Indication of Conformity

	<p>This product complies with the directive of the Council of the European Communities on the approximation of the laws of the Member States relating to electromagnetic compatibility (EMC Council Directive 89/336/EEC) and concerning electrical equipment for use within specified voltage limits (Low-voltage Directive 73/23 EEC).</p> <p>This conformity has been established by means of tests conducted by Siemens AG in accordance with Article 10 of the Council Directive in agreement with the generic standards EN 61000-6-2 and EN 61000-6-4 for the EMC directive, and with the standard EN 60255-6 for the low-voltage directive.</p> <p>The device has been designed and produced for industrial use.</p> <p>The product conforms with the international standards of the series IEC 60255 and the German standard VDE 0435.</p>
---	--

Additional Standards IEEE Std C37.90-*



IND. CONT. EQ.
69CA



IND. CONT. EQ.

Additional Support

Should further information on the System SIPROTEC 4 be desired or should particular problems arise which are not covered sufficiently for the purchaser's purpose, the matter should be referred to the local Siemens representative.

Our Customer Support Center provides a 24-hour service.

Phone: 01 80/5 24 70 00

Fax: 01 80/5 24 24 71

e-mail: support.energy@siemens.com

Training Courses

Enquiries regarding individual training courses should be addressed to our Training Center:

Siemens AG

Power Transmission and Distribution

Siemens Power Academy TD

Humboldt Street 59

90459 Nuremberg

Telephone: 0911 / 4 33-70 05

Fax: 0911 / 4 33-79 29

Internet: www.ptd-training.de

Safety Information

This manual does not constitute a complete index of all required safety measures for operation of the equipment (module, device), as special operational conditions may require additional measures. However, it comprises important information that should be noted for purposes of personal safety as well as avoiding material damage. Information that is highlighted by means of a warning triangle and according to the degree of danger, is illustrated as follows.



DANGER!

Danger indicates that death, severe personal injury or substantial material damage will result if proper precautions are not taken.



WARNING!

indicates that death, severe personal injury or substantial property damage may result if proper precautions are not taken.



Caution!

indicates that minor personal injury or property damage may result if proper precautions are not taken. This particularly applies to damage to or within the device itself and consequential damage thereof.



Note

indicates information on the device, handling of the device, or the respective part of the instruction manual which is important to be noted.



WARNING!

Qualified Personnel

Commissioning and operation of the equipment (module, device) as set out in this manual may only be carried out by qualified personnel. Qualified personnel in terms of the technical safety information as set out in this manual are persons who are authorized to commission, activate, to ground and to designate devices, systems and electrical circuits in accordance with the safety standards.

Use as prescribed

The operational equipment (device, module) may only be used for such applications as set out in the catalogue and the technical description, and only in combination with third-party equipment recommended or approved by Siemens.

The successful and safe operation of the device is dependent on proper handling, storage, installation, operation, and maintenance.

When operating an electrical equipment, certain parts of the device are inevitably subject to dangerous voltage. Severe personal injury or property damage may result if the device is not handled properly.

Before any connections are made, the device must be grounded to the ground terminal.

All circuit components connected to the voltage supply may be subject to dangerous voltage.

Dangerous voltage may be present in the device even after the power supply voltage has been removed (capacitors can still be charged).

Operational equipment with exposed current transformer circuits may not be operated.

The limit values as specified in this manual or in the operating instructions may not be exceeded. This aspect must also be observed during testing and commissioning.

Typographic and Symbol Conventions

The following text formats are used when literal information from the device or to the device appear in the text flow:

Parameter Names

Designators of configuration or function parameters which may appear word-for-word in the display of the device or on the screen of a personal computer (with operation software DIGSI), are marked in bold letters in monospace type style. The same applies to the titles of menus.

1234A

Parameter addresses have the same character style as parameter names. Parameter addresses contain the suffix **A** in the overview tables if the parameter can only be set in DIGSI via the option **Display additional settings**.

Parameter Options

Possible settings of text parameters, which may appear word-for-word in the display of the device or on the screen of a personal computer (with operation software DIGSI), are additionally written in italics. The same applies to the options of the menus.

„Messages“

Designators for information, which may be output by the relay or required from other devices or from the switch gear, are marked in a monospace type style in quotation marks.

Deviations may be permitted in drawings and tables when the type of designator can be obviously derived from the illustration.

The following symbols are used in drawings:

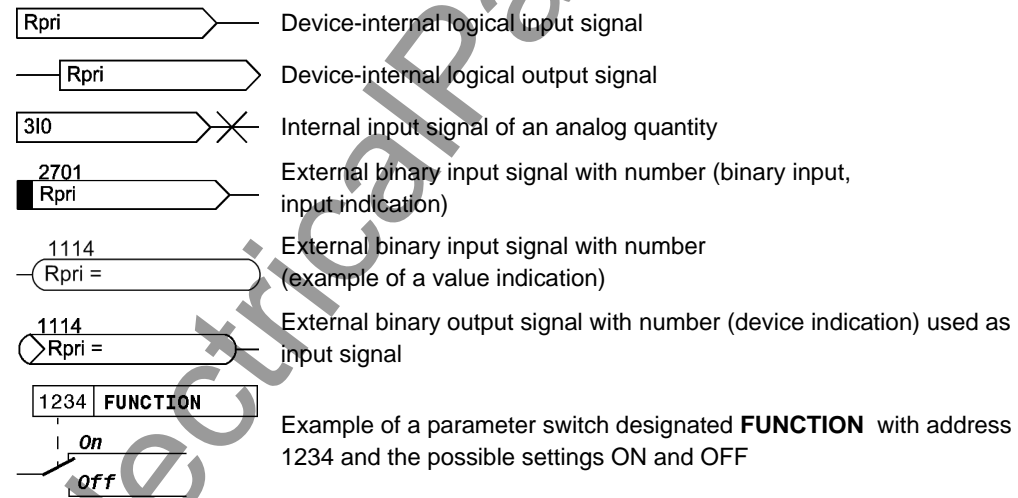

Besides these, graphical symbols are used in accordance with IEC 60617-12 and IEC 60617-13 or similar. Some of the most frequently used are listed below:

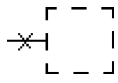

Input signal of analog quantity

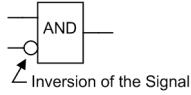

AND-gate operation of input values

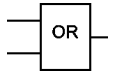

OR-gate operation of input values

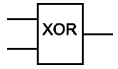

Exklusiv OR-gate (antivalence): output is active, if **one** of the inputs is active

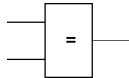

Coincidence gate (equivalence): output is active, if **both** inputs are active or inactive at the same time

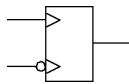

Dynamic inputs (edge-triggered) above with positive, below with negative edge

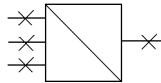

Formation of one analog output signal from a number of analog input signals

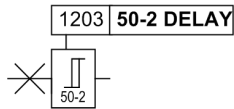

Limit stage with setting address and parameter designator (name)

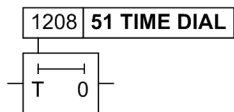

Timer (pickup delay T, example adjustable) with setting address and parameter designator (name)

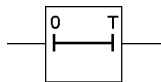

Timer (dropout delay T, example non-adjustable)

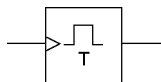

Dynamic triggered pulse timer T (monoflop)

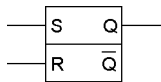

Static memory (RS-flipflop) with setting input (S), resetting input (R), output (Q) and inverted output (\bar{Q})

■

Contents

- 1 Introduction.....17**
 - 1.1 Overall Operation.....18
 - 1.2 Application Scope.....21
 - 1.3 Characteristics.....23

- 2 Functions.....27**
 - 2.1 General.....28
 - 2.1.1 Functions Overview.....28
 - 2.1.1.1 Description.....28
 - 2.1.1.2 Setting Notes.....29
 - 2.1.1.3 Settings.....30
 - 2.1.2 Device, General Settings.....32
 - 2.1.2.1 Description.....32
 - 2.1.2.2 Setting Notes.....32
 - 2.1.2.3 Settings.....33
 - 2.1.2.4 Information List.....33
 - 2.1.3 Power System Data 1.....35
 - 2.1.3.1 Description.....35
 - 2.1.3.2 Setting Notes.....35
 - 2.1.3.3 Settings.....40
 - 2.1.3.4 Information List.....41
 - 2.1.4 Oscillographic Fault Records.....41
 - 2.1.4.1 Description.....41
 - 2.1.4.2 Setting Notes.....42
 - 2.1.4.3 Settings.....43
 - 2.1.4.4 Information List.....43
 - 2.1.5 Settings Groups.....43
 - 2.1.5.1 Description.....43
 - 2.1.5.2 Setting Notes.....44
 - 2.1.5.3 Settings.....44
 - 2.1.5.4 Information List.....44
 - 2.1.6 Power System Data 2.....45
 - 2.1.6.1 Description.....45
 - 2.1.6.2 Setting Notes.....45
 - 2.1.6.3 Settings.....46
 - 2.1.6.4 Information List.....46
 - 2.1.7 EN100-Module.....47
 - 2.1.7.1 Functional Description.....47
 - 2.1.7.2 Setting Notes.....47
 - 2.1.7.3 Information List.....47

2.2	Overcurrent Protection 50, 51, 50N, 51N	48
2.2.1	General	48
2.2.2	Definite Time, High-set Elements 50-3, 50-2, 50N-3, 50N-2	49
2.2.3	Definite Time Overcurrent Elements 50-1, 50N-1	52
2.2.4	Inverse Time Overcurrent Elements 51, 51N	55
2.2.5	Dynamic Cold Load Pickup Function	58
2.2.6	Inrush Restraint	58
2.2.7	Pickup Logic and Tripping Logic	61
2.2.8	Two-phase Time Overcurrent Protection	62
2.2.9	Fast Busbar Protection Using Reverse Interlocking	62
2.2.10	Setting Notes	63
2.2.11	Settings	72
2.2.12	Information List	75
2.3	Dynamic Cold Load Pickup	77
2.3.1	Description	77
2.3.2	Setting Notes	80
2.3.3	Settings	81
2.3.4	Information List	82
2.4	Single-Phase Overcurrent Protection	83
2.4.1	Functional Description	83
2.4.2	High-impedance Ground Fault Unit Protection	85
2.4.3	Tank Leakage Protection	87
2.4.4	Setting Notes	88
2.4.5	Settings	93
2.4.6	Information List	93
2.5	Negative Sequence Protection 46	94
2.5.1	Definite Time Characteristic	94
2.5.2	Inverse Time Characteristic 46-TOC	95
2.5.3	Setting Notes	98
2.5.4	Settings	101
2.5.5	Information List	101
2.6	Motor Protection	102
2.6.1	Motor Starting Protection 48	102
2.6.1.1	Description	102
2.6.1.2	Setting Notes	105
2.6.2	Motor Restart Inhibit 66	107
2.6.2.1	Description	107
2.6.2.2	Setting Notes	113
2.6.3	Load Jam Protection	117
2.6.3.1	Mode of Operation	117
2.6.3.2	Setting Notes	120
2.6.4	Motorprotection (Motor Starting Protection 48, Motor Restart Inhibit 66, LoadJam)	122
2.6.4.1	Settings	122
2.6.4.2	Information List	123

2.7	Thermal Overload Protection 49	124
2.7.1	Description	124
2.7.2	Setting Notes	128
2.7.3	Settings	133
2.7.4	Information List	133
2.8	Monitoring Functions	134
2.8.1	Measurement Supervision	134
2.8.1.1	General	134
2.8.1.2	Hardware Monitoring	134
2.8.1.3	Software Monitoring	136
2.8.1.4	Monitoring of the External Transformer Circuits	137
2.8.1.5	Setting Notes	138
2.8.1.6	Settings	139
2.8.1.7	Information List	139
2.8.2	Trip Circuit Supervision 74TC	140
2.8.2.1	Description	140
2.8.2.2	Setting Notes	143
2.8.2.3	Settings	144
2.8.2.4	Information List	144
2.8.3	Malfunction Responses of the Monitoring Functions	144
2.8.3.1	Description	144
2.9	Ground Fault Protection 50N(s), 51N(s)	147
2.9.1	Current Elements 50Ns, 51Ns	147
2.9.2	Logic	148
2.9.3	Setting Notes	150
2.9.4	Settings	154
2.9.5	Information List	155
2.10	Intermittent Ground Fault Protection	156
2.10.1	Description	156
2.10.2	Setting Notes	160
2.10.3	Settings	161
2.10.4	Information List	161
2.11	Automatic Reclosing System 79	162
2.11.1	Program Execution	162
2.11.2	Blocking	167
2.11.3	Status Recognition and Monitoring of the Circuit Breaker	168
2.11.4	Controlling Protection Elements	170
2.11.5	Zone Sequencing (not available for models 7SJ6***-**A**-)	172
2.11.6	Setting Notes	173
2.11.7	Settings	180
2.11.8	Information List	183
2.12	Breaker Failure Protection 50BF	185
2.12.1	Description	185
2.12.2	Setting Notes	189
2.12.3	Settings	190
2.12.4	Information List	190

2.13	Flexible Protection Functions	191
2.13.1	Function Description	191
2.13.2	Setting Notes	195
2.13.3	Settings	198
2.13.4	Information List	199
2.14	Temperature Detection via RTD Boxes	200
2.14.1	Description	200
2.14.2	Setting Notes	201
2.14.3	Settings	203
2.14.4	Information List	208
2.15	Phase Rotation	209
2.15.1	Description	209
2.15.2	Setting Notes	210
2.16	Function Logic	211
2.16.1	Pickup Logic of the Entire Device	211
2.16.2	Tripping Logic of the Entire Device	212
2.16.3	Setting Notes	212

2.17	Auxiliary Functions	213
2.17.1	Message Processing	213
2.17.1.1	LED Displays and Binary Outputs (Output Relays)	213
2.17.1.2	Information on the Integrated Display (LCD) or Personal Computer	214
2.17.1.3	Information to a Substation Control Center	215
2.17.2	Statistics	216
2.17.2.1	Description	216
2.17.2.2	Circuit Breaker Maintenance	217
2.17.2.3	Motor Statistics	223
2.17.2.4	Setting Notes	224
2.17.2.5	Information List	226
2.17.3	Measurement	227
2.17.3.1	Display of Measured Values	227
2.17.3.2	Transfer of Measured Values	228
2.17.3.3	Information List	229
2.17.4	Average Measurements	230
2.17.4.1	Description	230
2.17.4.2	Setting Notes	230
2.17.4.3	Settings	230
2.17.4.4	Information List	231
2.17.5	Min/Max Measurement Setup	231
2.17.5.1	Description	231
2.17.5.2	Setting Notes	231
2.17.5.3	Settings	231
2.17.5.4	Information List	232
2.17.6	Set Points for Measured Values	232
2.17.6.1	Description	233
2.17.6.2	Setting Notes	233
2.17.6.3	Information List	233
2.17.7	Set Points for Statistic	234
2.17.7.1	Description	234
2.17.7.2	Setting Notes	234
2.17.7.3	Information List	234
2.17.8	Commissioning Aids	235
2.17.8.1	Description	235
2.17.9	Web Monitor	237
2.17.9.1	General	237
2.17.9.2	Functions	238
2.17.9.3	Operating Modes	241
2.17.9.4	Display Example	242
2.17.9.5	Setting Notes	243

2.18	Breaker Control	244
2.18.1	Control Device	244
2.18.1.1	Description	244
2.18.1.2	Information List	245
2.18.2	Types of Commands	246
2.18.2.1	Description	246
2.18.3	Command Sequence	247
2.18.3.1	Description	247
2.18.4	System Interlocking	248
2.18.4.1	Description	248
2.18.5	Command Logging	256
2.18.5.1	Description	256
3	Mounting and Commissioning	257
3.1	Mounting and Connections	258
3.1.1	Configuration Information	258
3.1.2	Hardware Modifications	262
3.1.2.1	General	262
3.1.2.2	Disassembly	264
3.1.2.3	Switch elements on the PCBs	266
3.1.2.4	Interface Modules	276
3.1.2.5	Reassembly	281
3.1.3	Installation	282
3.1.3.1	Panel Flush Mounting	282
3.1.3.2	Rack Mounting and Cubicle Mounting	283
3.1.3.3	Panel Flush Mounting	284
3.2	Checking Connections	285
3.2.1	Checking Data Connections of Serial Interfaces	285
3.2.2	Checking System Connections	288
3.3	Commissioning	290
3.3.1	Test Mode and Transmission Block	291
3.3.2	Testing the System Interface	291
3.3.3	Checking the Status of Binary Inputs and Outputs	293
3.3.4	Tests for Circuit Breaker Failure Protection	296
3.3.5	Testing User-Defined Functions	297
3.3.6	Current and Phase Rotation Testing	298
3.3.7	Test for High Impedance Protection	298
3.3.8	Testing the Reverse Interlocking Scheme	299
3.3.9	Checking the Temperature Measurement via RTD-Box	299
3.3.10	Trip/Close Tests for the Configured Operating Devices	301
3.3.11	Creating Oscillographic Recordings for Tests	302
3.4	Final Preparation of the Device	303

4	Technical Data	305
4.1	General Device Data	306
4.1.1	Analog Inputs	306
4.1.2	Auxiliary Voltage	306
4.1.3	Binary Inputs and Outputs	307
4.1.4	Communication Interfaces	309
4.1.5	Electrical Tests	313
4.1.6	Mechanical Stress Tests	315
4.1.7	Climatic Stress Tests	316
4.1.8	Service Conditions	316
4.1.9	Certifications	317
4.1.10	Design	317
4.2	Definite-Time Overcurrent Protection 50(N)	318
4.3	Inverse-Time Overcurrent Protection 51(N)	320
4.4	Inrush Restraint	331
4.5	DynamiC Cold Load Pickup	332
4.6	Single-phase Overcurrent Protection	333
4.7	Negative Sequence Protection 46-1, 46-2	334
4.8	Negative Sequence Protection 46-TOC	335
4.9	Motor Starting Protection 48	341
4.10	Motor Restart Inhibit 66	342
4.11	Load Jam Protection	343
4.12	Thermal Overload Protection 49	344
4.13	Ground Fault Protection 50N(s), 51N(s)	346
4.14	Intermittent Ground Fault Protection	350
4.15	Automatic Reclosing System 79	351
4.16	Breaker Failure Protection 50BF	352
4.17	Flexible Protection Functions	353
4.18	Temperature Detection via RTD Boxes	355
4.19	User-defined Functions (CFC)	356
4.20	Additional Functions	361
4.21	Breaker Control	365
4.22	Dimensions	366
4.22.1	Panel Flush and Cubicle Mounting (Housing Size $\frac{1}{3}$)	366
4.22.2	Panel Surface Mounting (Housing Size $\frac{1}{3}$)	367
4.22.3	Varistor	367
A	Appendix	369
A.1	Ordering Information and Accessories	370
A.1.1	Ordering Information	370
A.1.1.1	7SJ61 V4.7	370
A.1.2	Accessories	373

A.2	Terminal Assignments	376
A.2.1	Housing for Panel Flush and Cubicle Mounting	376
A.2.2	Housing for Panel Surface Mounting	379
A.2.3	Terminal Assignment on Housing for Panel Surface Mounting	382
A.2.4	Assignment of the Female Connectors	384
A.3	Connection Examples	385
A.3.1	Connection Examples for Current Transformers, all Devices	385
A.3.2	Connection Examples for RTD-Box, all Devices	389
A.4	Current Transformer Requirements	391
A.4.1	Accuracy limiting factors	391
	Effective and Rated Accuracy Limiting Factor	391
	Calculation example according to IEC 60044-1	391
A.4.2	Class conversion	392
A.4.3	Cable core balance current transformer	393
	General	393
	Requirements	393
	Class accuracy	393
A.5	Default Settings	394
A.5.1	LEDs	394
A.5.2	Binary Input	394
A.5.3	Binary Output	395
A.5.4	Function Keys	395
A.5.5	Default Display	396
A.5.6	Pre-defined CFC Charts	397
A.6	Protocol-dependent Functions	399
A.7	Functional Scope	400
A.8	Settings	402
A.9	Information List	415
A.10	Group Alarms	433
A.11	Measured Values	434
	Literature	437
	Glossary	439
	Index	451

Introduction

The SIPROTEC 7SJ61 device is introduced in this chapter. An overview of the 7SJ61 is presented with its applications areas, characteristics, and scope of functions.

1.1	Overall Operation	18
1.2	Application Scope	21
1.3	Characteristics	23

1.1 Overall Operation

The numerical, multi-functional protection device SIPROTEC 7SJ61 is equipped with a powerful microprocessor. It allows all tasks to be processed digitally, from the acquisition of measured quantities to sending commands to circuit breakers. Figure 1-1 shows the basic structure of the device.

Analog Inputs

The measuring inputs (MI) convert the currents coming from the instrument transformers and adapt them to the level appropriate for the internal processing of the device. The device has 4 current inputs, three of these are for the input of the phase currents. Depending on the model, the fourth current input (I_N) may be used for measuring the ground fault current I_N (current transformer starpoint) or for a separate ground current transformer (for ground fault detection I_{Ns}). The analog input quantities are passed on to the input amplifiers (IA).

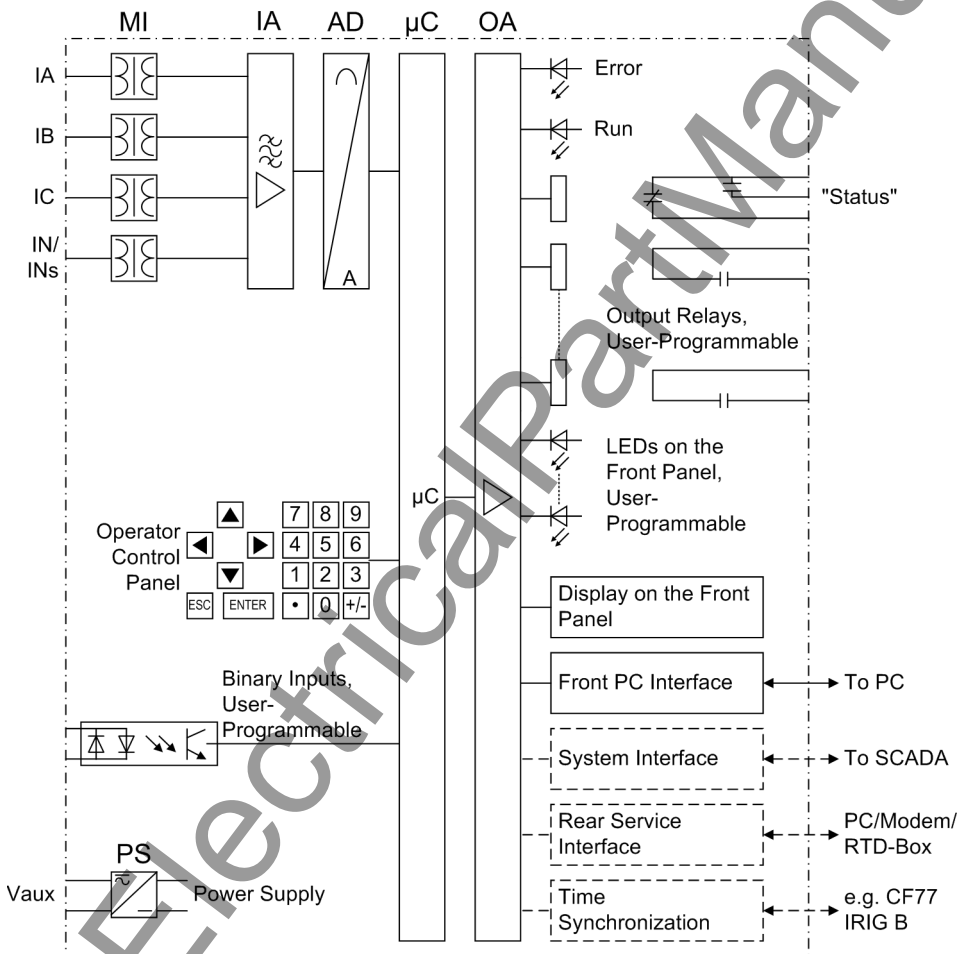

Figure 1-1 Hardware structure of the numerical multi-functional device 7SJ61

The input amplifier IA stage provides a high-resistance termination for the input quantities. It consists of filters that are optimized for measured-value processing with regard to bandwidth and processing speed.

The analog-to-digital (AD) element consists of a multiplexor, an analog-to-digital (A/D) converter and of memory components for the transmission of digital signals to the microcomputer system.

Microcomputer System

Apart from processing the measured values, the microcomputer system (μ C) also executes the actual protection and control functions. They especially include:

- Filtering and preparation of the measured quantities
- Continuous monitoring of the measured quantities
- Monitoring of the pickup conditions for the individual protective functions
- Interrogation of limit values and sequences in time
- Control of signals for the logic functions
- Output of control commands for switching devices
- Recording of messages, fault data and fault values for analysis
- Management of the operating system and the associated functions such as data recording, real-time clock, communication, interfaces, etc.
- The information is distributed via output amplifiers (OA).

Binary Inputs and Outputs

Binary inputs and outputs to and from the computer system are relayed via the input/output modules. The computer system obtains the information from the system (e.g. remote resetting) or the external equipment (e.g. blocking commands). Outputs are, in particular, commands to the switchgear units and annunciations for remote signalling of important events and statuses.

Front Elements

Optical indicators (LEDs) and a front display panel (LC display) provide information on the function of the device, and indicate events, states and measured values.

Integrated control and numeric keys in conjunction with the LCD facilitate local interaction with the device. Via these elements all information of the device such as configuration and setting parameters, operating and fault messages, and measured values can be accessed. Setting parameters may be changed in the same way.

In addition, control of circuit breakers and other equipment is possible from the front panel of the device.

Serial Interfaces

The **Front PC Interface** is provided for local communications with a personal computer using the DIGSI software. This facilitates a comfortable handling of all device functions.

The **Rear Service Interface** can also be used to communicate with the relay from a PC running the DIGSI software. This interface is especially well suited for a permanent connection of the devices to the PC or for operation via a modem. The service interface can also be used to connect an RTD box (= resistance temperature detector) for obtaining external temperatures (e.g. for overload protection).

All data can be transferred to a central control center or monitoring system via the serial **System Interface**. This interface may be provided with various protocols and physical transmission schemes to suit the particular application.

A further interface is provided for the **time synchronization** of the internal clock via external synchronization sources.

A range of communication protocols are available from a variety of additional interface modules.

The operator or service interface allows you to operate the device from a remote location or on site using a standard browser. This is possible during commissioning, checking and also during operation of the devices. The SIPROTEC 4 Standard „WEBMonitor“ is available for this task.

Power Supply

A power supply unit (Vaux or PS) delivers power to the functional units on the different voltage levels. Voltage dips may occur if the voltage supply system (substation battery) becomes short-circuited. Usually, they are bridged by a capacitor (see also Technical Data).

1.2 Application Scope

The numerical, multi-functional SIPROTEC 4 7SJ61 is a versatile device designed for protection, control and monitoring of busbar feeders. For line protection, the device can be used in networks with earthed, low resistance earthed, isolated or compensated neutral point. It is suited for networks that are radial and supplied from a single source or open looped networks. The device is equipped with motor protection applicable for asynchronous machines of all sizes.

The device includes the functions that are necessary for protection, for monitoring of circuit breaker positions, and control of the circuit breakers in straight bus applications or breaker-and-a-half configurations; therefore, the devices can be universally employed. The devices also provide excellent backup facilities of differential protective schemes of lines, transformers, generators, motors, and busbars of all voltage levels.

Protective Functions

Non-directional overcurrent protection (50, 50N, 51, 51N) is the basis of the device. There are three definite time overcurrent protective elements and one inverse time element for the phase currents and the ground current. For inverse time overcurrent protective elements, several curves of different standards are provided. Alternatively, user-defined characteristic can be programmed.

Depending on the variant ordered, the overcurrent time protection can feature breaker failure protection and ground fault protection for high-resistance ground short-circuits and faults.

In addition to the fault protection functions already mentioned, other protective functions are available. Some of them depend on the version of the device that is ordered. These additional functions include negative sequence protection (46), thermal overload protection (49) with start inhibit for motors (66/68), and motor starting protection (48), as well as automatic reclosing (79) which allows different reclosing cycles on overhead lines. An automatic reclosing system may also be connected externally.

A protection feature can be ordered for the detection of intermittent ground faults which detects and accumulates transient ground faults.

External detectors account for ambient temperatures or coolant temperatures (by means of an external RTD-box).

Control Functions

The device features a control function for activating and deactivating switchgears via the integrated operator panel, the system interface, binary inputs, and the serial port using a personal computer with DIGSI.

The status of the primary equipment can be transmitted to the device via auxiliary contacts connected to binary inputs. The present status (or position) of the primary equipment can be displayed on the device, and used for interlocking or plausibility monitoring. The number of the operating equipment to be switched is limited by the binary inputs and outputs available in the device or the binary inputs and outputs allocated for the switch position indications. Depending on the primary equipment being controlled, one binary input (single point indication) or two binary inputs (double point indication) may be used for this process.

The capability of switching primary equipment can be restricted by a setting associated with switching authority (Remote or Local), and by the operating mode (interlocked/non-interlocked, with or without password request).

Processing of interlocking conditions for switching (e.g. switchgear interlocking) can be established with the aid of integrated, user-configurable logic functions.

Messages and Measured Values; Recording of Event and Fault Data

The operational indications provide information about conditions in the power system and the device. Measurement quantities and values that are calculated can be displayed locally and communicated via the serial interfaces.

Device messages can be assigned to a number of LEDs on the front cover (allocatable), can be externally processed via output contacts (allocatable), linked with user-definable logic functions and/or issued via serial interfaces.

During a fault (system fault) important events and changes in conditions are saved in fault protocols (Event Log or Trip Log). Instantaneous fault values are also saved in the device and may be analyzed subsequently.

Communication

The following interfaces are available for the communication with external operating, control and memory systems.

A 9-pole DSUB miniature female connector on the front panel serves the purpose of local communication with a PC. By means of the SIPROTEC 4 operating software DIGSI, all operational and evaluation tasks can be executed via this **operator** interface, such as specifying and modifying configuration parameters and settings, configuring user-specific logic functions, retrieving operational messages and measured values, inquiring device conditions and measured values, issuing control commands.

Depending on the individual ordering variant, additional interfaces are located at the rear side of the device. They serve to establish extensive communication with other digital operating, control and memory components:

The **service** interface can be operated via electrical data lines or fiber optics and also allows communication via modem. For this reason, remote operation is possible via personal computer and the DIGSI operating software, e.g. to operate several devices via a central PC.

The **system** interface ensures the central communication between the device and the substation controller. It can also be operated via data lines or fiber optic cables. Standard protocols are available to transmit data according to IEC 60870-5-103 via system port. The integration of the devices into the automation systems SINAUT LSA and SICAM can also take place with this profile.

The EN-100-module allows the devices to be integrated in 100-Mbit-Ethernet communication networks in control and automation systems using protocols according to IEC61850. Besides control system integration, this interface enables DIGSI-communication and inter-relay communication via GOOSE.

Alternatively, field bus coupling with PROFIBUS FMS is available for SIPROTEC 4. The PROFIBUS FMS according to DIN 19245 is an open communication standard that particularly has wide acceptance in process control and automation engineering, with exceptional high performance. A profile has been defined for the PROFIBUS communication that covers all of the information types required for protection and process control engineering. The integration of the devices into the power automation system SICAM can also take place with this profile.

Besides the field-bus connection with PROFIBUS FMS, further couplings are possible with PROFIBUS DP and the protocols DNP3.0 and MODBUS. These protocols do not support all possibilities which are offered by PROFIBUS FMS.

Furthermore, a redundant IEC 60870-5-103 interface is available.

1.3 Characteristics

General Characteristics

- Powerful 32-bit microprocessor system.
- Complete digital processing and control of measured values, from the sampling of the analog input quantities to the initiation of outputs, for example, tripping or closing circuit breakers or other switchgear devices.
- Total electrical separation between the internal processing stages of the device and the external transformer, control, and DC supply circuits of the system because of the design of the binary inputs, outputs, and the DC or AC converters.
- Complete set of functions necessary for the proper protection of lines, feeders, motors, and busbars.
- Easy device operation through an integrated operator panel or by means of a connected personal computer running DIGSI.
- Continuous calculation and display of measured and metered values on the front of the device.
- Storage of min/max measured values (slave pointer function) and storage of long-term mean values.
- Recording of event and fault data for the last 8 system faults (fault in a network) with real-time information as well as instantaneous values for fault recording for a maximum time range of 20 s.
- Constant monitoring of the measured quantities, as well as continuous self-diagnostics covering the hardware and software.
- Communication with SCADA or substation controller equipment via serial interfaces through the choice of data cable, modem, or optical fibers.
- Battery-buffered clock that can be synchronized with an IRIG-B (via satellite) or DCF77 signal, binary input signal, or system interface command.
- Motor Statistics: Recording of important statistical motor data (operation and startup information).
- Switching statistics: Recording of the number of trip signals instigated by the device and logging of currents switched off last by the device, as well as accumulated short circuit currents of each pole of the circuit breaker.
- Operating Hours Counter: Tracking of operating hours of the equipment being protected.
- Commissioning aids such as connection check, status indication of all binary inputs and outputs, easy check of system interface and influencing of information of the system interface during test operation.

Time Overcurrent Protection 50, 51, 50N, 51N

- Three definite time overcurrent protective elements and one inverse time overcurrent protective element for phase current and ground current I_N or summation current $3I_0$;
- two-phase operation of the time overcurrent protection (I_A, I_C) is possible;
- Different curves of common standards are available for 51 and 51N, or a user-defined characteristic;
- Blocking capability e.g. for reverse interlocking with any element;
- Instantaneous tripping by any overcurrent element upon switch onto fault is possible;
- In-rush restraint with second harmonic oscillation.

Ground Fault Protection 50N, 51N

- Three definite time overcurrent protective elements and one inverse time overcurrent protective element for high-resistance ground faults in grounded systems;
- Different curves of common standards are available for 51 and 51N, or a user-defined characteristic;
- In-rush restraint with second harmonic oscillation;
- Instantaneous tripping by any overcurrent element upon switch onto fault is possible.

Dynamic Cold Load Pick-up Function 50C, 50NC, 51C, 51NC, 67C, 67NC

- Dynamic changeover of time overcurrent protection settings, e.g. when cold load conditions are anticipated;
- Detection of cold load condition via circuit breaker position or current threshold;
- Activation via automatic reclosure (AR) possible;
- Start also possible via binary input.

Single-Phase Overcurrent Protection

- Evaluation of the measured current via the sensitive or insensitive ground current transformer;
- Suitable as differential protection that includes the neutral point current on a transformer side, a generator side or a motor side or for a grounded reactor set;
- As tank leakage protection against illegal leakage currents between transformer casing and ground.

Negative Sequence Protection 46

- Evaluation of negative sequence component of the currents;
- Two definite-time elements 46-1 and 46-2 and one inverse-time element 46-TOC; curves of common standards are available for 46-TOC.

Motor Starting Protection 48

- Inverse time tripping characteristic based on an evaluation of the motor starting current;
- Definite time delay for blocked rotor.

Motor Restart Inhibit 66, 86

- Approximate replica of excessive rotor temperature;
- Startup is permitted only if the rotor has sufficient thermal reserves for a complete startup;
- Disabling of the start inhibit is possible if an emergency startup is required.

Load Jam Protection for Motors 51M

- Protection of motors during sudden rotor blocking
- Evaluation of the positive sequence system of phase currents
- Evaluation of the circuit breaker switching state
- Blocking of function during motor standstill and during motor startup

Thermal Overload Protection 49

- Thermal profile of energy losses (overload protection has total memory capability);
- True r.m.s. calculation;
- Adjustable thermal alarm level;
- Adjustable alarm level based on current magnitude;
- Additional time constant setting for motors to accommodate the motor at standstill;
- Integration of ambient temperature or coolant temperature is possible via external temperature sensors and RTD-Box.

Monitoring Functions

- Availability of the device is greatly increased because of self-monitoring of the internal measurement circuits, power supply, hardware, and software;
- Supervision of the current transformer secondary circuits by means of sum and symmetry checks.
- Trip circuit monitoring;
- Phase rotation check.

Ground Fault Detection 50N(s), 51N(s)

- Two-element ground fault detection: High-current element 50Ns-1 and 50Ns-2;
- High sensitivity (as low as 1 mA);
- The overcurrent protection element may be operated with either a definite time or an inverse time delay;
- One user-defined and two logarithmic-inverse current/time curves are available for inverse time O/C protection;
- Optionally applicable as additional ground fault protection.

Intermittent Ground Fault Protection

- Detects and accumulates intermittent ground faults;
- Tripping after configurable total time.

Automatic Reclosing System 79

- Single-shot or multi-shot;
- With separate dead times for the first and all succeeding shots;
- Protective elements that initiate automatic reclosing are selectable. The choices can be different for phase faults and ground faults;
- Different programs for phase and ground faults;
- Interaction to time overcurrent protection element and ground fault elements. They can be blocked in dependence of the reclosing cycle or released instantaneously;

Breaker Failure Protection 50 BF

- Checking current flow and/or evaluation of the circuit breaker auxiliary contacts;
- Initiated by the tripping of any integrated protective element that trips the circuit breaker;
- Initiation possible via a binary input from an external protective device.

Flexible Protective Functions

- Up to 20 protection functions which can be set individually to operate in three-phase or single-phase mode;
- Any calculated or directly measured value can be evaluated on principle;
- Standard protection logic function with definite time characteristic;
- Internal and configurable pickup and dropout delay;
- Modifiable message texts.

RTD-Boxes

- Detection of any ambient temperatures or coolant temperatures by means of RTD-Boxes and external temperature sensors.

Phase Rotation

- Selectable ABC or ACB by setting (static) or binary input (dynamic).

Circuit-Breaker Maintenance

- Statistical methods to help adjust maintenance intervals for CB contacts according to their actual wear;
- several independent subfunctions have been implemented (ΣI -procedure, ΣI^x -procedure, 2P-procedure and I^2t -procedure);
- Acquisition and conditioning of measured values for all subfunctions operates phase-selective using one procedure-specific threshold per subfunction.

User-defined Functions

- Internal and external signals can be logically combined to establish user-defined logic functions;
- All common Boolean operations are available for programming (AND, OR, NOT, Exclusive OR, etc.);
- Time delays and limit value interrogation;
- Processing of measured values, including zero suppression, adding a knee curve for a transducer input, and live-zero monitoring;

Breaker Control

- Circuit breakers can be opened and closed via specific process control keys (models with graphic displays only), the programmable function keys on the front panel, via the system interface (e.g. by SICAM or SCADA), or via the front PC interface using a personal computer with DIGSI);
- Circuit breakers are monitored via the breaker auxiliary contacts;
- Plausibility monitoring of the circuit breaker position and check of interlocking conditions.

■

Functions

2

This chapter describes the numerous functions available on the SIPROTEC 4 device 7SJ61. It shows the setting possibilities for each function in maximum configuration. Information with regard to the determination of setting values as well as formulas, if required, are also provided.

Based on the following information, it can also be determined which of the provided functions should be used.

2.1	General	28
2.2	Overcurrent Protection 50, 51, 50N, 51N	48
2.3	Dynamic Cold Load Pickup	77
2.4	Single-Phase Overcurrent Protection	83
2.5	Negative Sequence Protection 46	94
2.6	Motor Protection	102
2.7	Thermal Overload Protection 49	124
2.8	Monitoring Functions	134
2.9	Ground Fault Protection 50N(s), 51N(s)	147
2.10	Intermittent Ground Fault Protection	156
2.11	Automatic Reclosing System 79	162
2.12	Breaker Failure Protection 50BF	185
2.13	Flexible Protection Functions	191
2.14	Temperature Detection via RTD Boxes	200
2.15	Phase Rotation	209
2.16	Function Logic	211
2.17	Auxiliary Functions	213
2.18	Breaker Control	244

2.1 General

The settings associated with the various device functions may be modified using the operating or service interface in DIGSI in conjunction with a personal computer. Some parameters may also be changed using the controls on the front panel of the device. The procedure is set out in detail in the SIPROTEC System Description /1/.

2.1.1 Functions Overview

The 7SJ61 relay contains protection functions as well as many other functions. The hardware and firmware is designed for this scope of functions. Additionally, the control functions can be matched to the system requirements. Individual functions can be activated or deactivated during the configuration procedure. The interaction of functions may also be modified.

2.1.1.1 Description

Configuration of Functions

Example for the configuration of functional scope:

A protected system consists of overhead lines and underground cables. Since automatic reclosing is only needed for the overhead lines, the automatic reclosing function is not configured or "Disabled" for the relays protecting the underground cables.

The available protection and additional functions must be configured as **Enabled** or **Disabled**. For individual functions a choice between several alternatives is possible, as described below.

Functions configured as **Disabled** are not processed by the 7SJ61. There are no indications, and corresponding settings (functions, limit values) are not queried during configuration.



Note

Available functions and default settings depend on the ordering code of the relay (see Section A.1 for details).

2.1.1.2 Setting Notes

Setting the Functional Scope

Configuration settings can be entered using a PC and the software program DIGSI and transferred via the front serial port or the rear service interface of the device. The operation via DIGSI is explained in the SIPROTEC 4 System Description.

For changing configuration parameters in the device, password no.7 is required (for parameter set). Without the password, the settings can be read but not modified and transmitted to the device.

The functional scope with the available options is set in the **Functional Scope** dialog box to match plant requirements.

Special Features

Most settings are self-explanatory. The special features are described below.

If you want to use the setting group change function, set address 103 **Grp Chge OPTION** to **Enabled**. Simple and fast changeover between up to four different setting groups is possible in service. Only **one** setting group can be selected and used if this option is **Disabled**.

For the overcurrent elements of the time overcurrent protection (separately for phase currents and ground current), various tripping characteristics can be selected at address 112 **Charac. Phase** and 113 **Charac. Ground**. If only the definite characteristic is desired, then **Definite Time** should be selected. Additionally, depending on the version ordered, various inverse time characteristics, based on either IEC (**TOC IEC**) standards or ANSI (**TOC ANSI** standards), or user-defined characteristic are available for selection. The dropout behaviour of the IEC and ANSI characteristics will be specified later with settings (addresses 1210 and 1310). But for the user-defined characteristic, you can choose in address 112 and 113 whether to specify only the pickup characteristic (**User Defined PU**) or the pickup and the dropout characteristic (**User def. Reset**).

Additionally, the superimposed high-current elements 50-2 and 50-3 are available in all these cases. Time overcurrent protection may be set to **Disabled** during configuration.

For (sensitive) ground fault detection, address 131 **Sens. Gnd Fault** is used to specify whether this function should be enabled with definite time tripping characteristics (**Definite Time**), a **User Defined PU** and two logarithmic inverse characteristics or **Disabled**.

For the intermittent ground fault protection, you can specify the measured quantity (**with Ignd, with 3I0** or **with Ignd, sens.**) to be used by this protection function at address 133 **INTERM.EF**.

For negative sequence current protection, address 140 **46** is used to specify whether the tripping characteristics should be **Definite Time**, **TOC ANSI** or **TOC IEC**, or whether the function is to be **Disabled**.

For overload protection, address 142 **49** allows you to specify whether the thermal replica of the overload protection will account for a coolant temperature or ambient temperature (**With amb. temp.**) or not (**No ambient temp**), or whether the entire function is **Disabled**.

For the circuit-breaker maintenance function, several options are available under address 172 **52 B.WEAR MONIT**. Irrespective of this, the basic functionality of the summation current formation (ΣI procedure) is always active. It requires no further configurations and adds up the tripping currents of the trips initiated by the protection functions.

When selecting the ΣI^x procedure, the sum of all tripping current powers is formed and issued as a reference value. The **2P procedure** continuously calculates the remaining lifespan of the circuit breaker.

With the **I²t procedure**, the square fault current integrals are formed via arc time and are issued as a reference value.

For more detailed information about the circuit breaker maintenance procedures, see Section 2.17.2.

When using trip circuit supervision, address 182 **74 Trip Ct Supv** allows you to select whether this function should work with two (**2 Binary Inputs**) or only one binary input (**1 Binary Input**) or if the function is **Disabled**.

If you want to detect an ambient temperature or a coolant temperature and e.g. send the information to the overload protection, specify in address 190 **RTD-BOX INPUT** the port to which the RTD-box is connected. For 7SJ61 Port C (service port) is used for this purpose. The number and transmission type of the temperature detectors (RTD = Resistance Temperature Detector) can be specified in address 191 **RTD CONNECTION: 6 RTD simplex** or **6 RTD HDX** (with one RTD-box) or **12 RTD HDX** (with two RTD-boxes). Implementation examples are given in the Appendix (under "Connection examples"). The settings in address 191 have to comply with those of the RTD-box (see Subsection 2.14.2, "RTD-box").

The flexible protection functions can be configured via parameter **FLEXIBLE FUNC.**. Up to 20 functions can be created. This is done by setting checkmarks at the functions. If the checkmark of a function is removed, all settings and configurations made previously will be lost. After re-selecting the function, all settings and configurations are in default setting. Setting of the flexible function is done in DIGSI under "Parameters", "Additional Functions" and "Settings". The configuration is done, as usual, under "Parameters" and "Configuration".

2.1.1.3 Settings

Addr.	Parameter	Setting Options	Default Setting	Comments
103	Grp Chge OPTION	Disabled Enabled	Disabled	Setting Group Change Option
104	OSC. FAULT REC.	Disabled Enabled	Enabled	Oscillographic Fault Records
112	Charac. Phase	Disabled Definite Time TOC IEC TOC ANSI User Defined PU User def. Reset	Definite Time	50/51
113	Charac. Ground	Disabled Definite Time TOC IEC TOC ANSI User Defined PU User def. Reset	Definite Time	50N/51N
117	Coldload Pickup	Disabled Enabled	Disabled	Cold Load Pickup
122	InrushRestraint	Disabled Enabled	Disabled	2nd Harmonic Inrush Restraint
127	50 1Ph	Disabled Enabled	Disabled	50 1Ph
131	Sens. Gnd Fault	Disabled Definite Time User Defined PU Log. inverse A Log. Inverse B	Disabled	(sensitive) Ground fault
133	INTERM.EF	Disabled with Ignd with 3I0 with Ignd,sens.	Disabled	Intermittent earth fault protection

Addr.	Parameter	Setting Options	Default Setting	Comments
140	46	Disabled TOC ANSI TOC IEC Definite Time	Disabled	46 Negative Sequence Protection
141	48	Disabled Enabled	Disabled	48 Startup Supervision of Motors
142	49	Disabled No ambient temp With amb. temp.	Disabled	49 Thermal Overload Protection
143	66 #of Starts	Disabled Enabled	Disabled	66 Startup Counter for Motors
144	LOAD JAM PROT.	Disabled Enabled	Disabled	Load Jam Protection
170	50BF	Disabled Enabled enabled w/ 3I0>	Disabled	50BF Breaker Failure Protection
171	79 Auto Recl.	Disabled Enabled	Disabled	79 Auto-Reclose Function
172	52 B.WEAR MONIT	Disabled Ix-Method 2P-Method I2t-Method	Disabled	52 Breaker Wear Monitoring
182	74 Trip Ct Supv	Disabled 2 Binary Inputs 1 Binary Input	Disabled	74TC Trip Circuit Supervision
190	RTD-BOX INPUT	Disabled Port C	Disabled	External Temperature Input
191	RTD CONNECTION	6 RTD simplex 6 RTD HDX 12 RTD HDX	6 RTD simplex	Ext. Temperature Input Connection Type
-	FLEXIBLE FUNC. 1..20	Flex. Function 01 Flex. Function 02 Flex. Function 03 Flex. Function 04 Flex. Function 05 Flex. Function 06 Flex. Function 07 Flex. Function 08 Flex. Function 09 Flex. Function 10 Flex. Function 11 Flex. Function 12 Flex. Function 13 Flex. Function 14 Flex. Function 15 Flex. Function 16 Flex. Function 17 Flex. Function 18 Flex. Function 19 Flex. Function 20	Please select	Flexible Functions

2.1.2 Device, General Settings

The device requires some general information. This may be, for example, the type of annunciation to be issued in the event of a power system fault occurs.

2.1.2.1 Description

Command-dependent Messages "No Trip – No Flag"

The indication of messages masked to local LEDs and the provision of spontaneous messages can be made dependent on whether the device has issued a trip signal. This information is then not output if during a system disturbance one or more protection functions have picked up but no tripping by the 7SJ61 resulted because the fault was cleared by a different device (e.g. on another line). These messages are then limited to faults in the line to be protected. These messages are then limited to faults in the line to be protected.

The following figure illustrates the creation of the reset command for stored messages. When the relay drops off, stationary conditions (fault display Target on PU / Target on TRIP; Trip / No Trip) decide whether the new fault will be stored or reset.

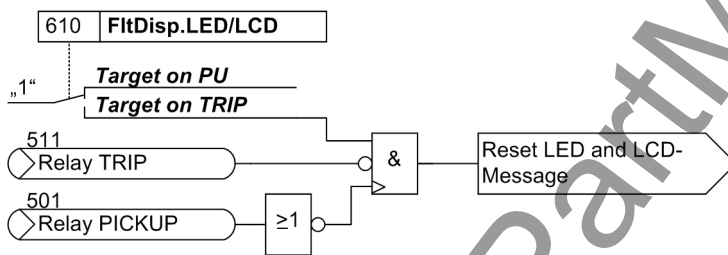

Figure 2-1 Creation of the reset command for the latched LED and LCD messages

2.1.2.2 Setting Notes

Fault Messages

A new pickup of a protection function generally turns off any previously set light displays so that only the latest fault is displayed at any one time. It can be selected whether the stored LED displays and the spontaneous messages on the display appear after the new pickup or only after a new trip signal is issued. In order to select the desired mode of display, select the Device submenu in the SETTINGS menu. Under address 610 **FltDisp.LED/LCD** the two options **Target on PU** and **Target on TRIP** ("No trip – no flag") can be selected.

Default Display Selection

In devices with 4-line displays and depending on the device version, a number of predefined image pages are available. The start page of the default display appearing after startup of the device can be selected in the device data via parameter 640 **Start image DD**. The available image pages are listed in Annex A.5.

2.1.2.3 Settings

Addr.	Parameter	Setting Options	Default Setting	Comments
610	FltDisp.LED/LCD	Target on PU Target on TRIP	Target on PU	Fault Display on LED / LCD
640	Start image DD	image 1 image 2 image 3 image 4	image 1	Start image Default Display

2.1.2.4 Information List

No.	Information	Type of Information	Comments
-	>Light on	SP	>Back Light on
-	Reset LED	IntSP	Reset LED
-	DataStop	IntSP	Stop data transmission
-	Test mode	IntSP	Test mode
-	Feeder gnd	IntSP	Feeder GROUNDED
-	Brk OPENED	IntSP	Breaker OPENED
-	HWTestMod	IntSP	Hardware Test Mode
-	SynchClock	IntSP_Ev	Clock Synchronization
-	Error FMS1	OUT	Error FMS FO 1
-	Error FMS2	OUT	Error FMS FO 2
-	Distur.CFC	OUT	Disturbance CFC
1	Not configured	SP	No Function configured
2	Non Existent	SP	Function Not Available
3	>Time Synch	SP_Ev	>Synchronize Internal Real Time Clock
5	>Reset LED	SP	>Reset LED
15	>Test mode	SP	>Test mode
16	>DataStop	SP	>Stop data transmission
51	Device OK	OUT	Device is Operational and Protecting
52	ProtActive	IntSP	At Least 1 Protection Funct. is Active
55	Reset Device	OUT	Reset Device
56	Initial Start	OUT	Initial Start of Device
67	Resume	OUT	Resume
68	Clock SyncError	OUT	Clock Synchronization Error
69	DayLightSavTime	OUT	Daylight Saving Time
70	Settings Calc.	OUT	Setting calculation is running
71	Settings Check	OUT	Settings Check
72	Level-2 change	OUT	Level-2 change
73	Local change	OUT	Local setting change
110	Event Lost	OUT_Ev	Event lost
113	Flag Lost	OUT	Flag Lost
125	Chatter ON	OUT	Chatter ON
140	Error Sum Alarm	OUT	Error with a summary alarm
144	Error 5V	OUT	Error 5V

No.	Information	Type of Information	Comments
145	Error 0V	OUT	Error 0V
146	Error -5V	OUT	Error -5V
147	Error PwrSupply	OUT	Error Power Supply
160	Alarm Sum Event	OUT	Alarm Summary Event
177	Fail Battery	OUT	Failure: Battery empty
178	I/O-Board error	OUT	I/O-Board Error
181	Error A/D-conv.	OUT	Error: A/D converter
183	Error Board 1	OUT	Error Board 1
184	Error Board 2	OUT	Error Board 2
185	Error Board 3	OUT	Error Board 3
186	Error Board 4	OUT	Error Board 4
187	Error Board 5	OUT	Error Board 5
188	Error Board 6	OUT	Error Board 6
189	Error Board 7	OUT	Error Board 7
191	Error Offset	OUT	Error: Offset
192	Error1A/5Awrong	OUT	Error:1A/5Ajumper different from setting
193	Alarm NO calibr	OUT	Alarm: NO calibration data available
194	Error neutralCT	OUT	Error: Neutral CT different from MLFB
220	CT Ph wrong	OUT	Error: Range CT Ph wrong
301	Pow.Sys.Flt.	OUT	Power System fault
302	Fault Event	OUT	Fault Event
303	sens Gnd flt	OUT	sensitive Ground fault
320	Warn Mem. Data	OUT	Warn: Limit of Memory Data exceeded
321	Warn Mem. Para.	OUT	Warn: Limit of Memory Parameter exceeded
322	Warn Mem. Oper.	OUT	Warn: Limit of Memory Operation exceeded
323	Warn Mem. New	OUT	Warn: Limit of Memory New exceeded
502	Relay Drop Out	SP	Relay Drop Out
510	Relay CLOSE	SP	General CLOSE of relay
545	PU Time	VI	Time from Pickup to drop out
546	TRIP Time	VI	Time from Pickup to TRIP

2.1.3 Power System Data 1

2.1.3.1 Description

The device requires certain basic data regarding the protected equipment, so that the device can adapt to its desired application. These may be, for instance, nominal power system and transformer data, measured quantity polarities and their physical connections, breaker properties (where applicable) etc. There are also certain parameters that are common to all functions, i.e. not associated with a specific protection, control or monitoring function. The following section discusses these data.

2.1.3.2 Setting Notes

General

This data can be entered directly at the device: Select the MAIN MENU by pressing the MENU key. The user should use the ▼ key to select **SETTINGS**, and then use the ► key to navigate to the SETTINGS display. To obtain the Power System Data display, select the **P.System Data 1** in **SETTINGS** display.

In DIGSI double-click on **Settings** to display the relevant selection. A dialog box will open under the option **P.System Data 1** with the tabs , , and Prot.Op. quant. where you can configure the individual parameters. The following descriptions are therefore structured accordingly.

Rated Frequency (Power System)

The rated system frequency is set at address 214 **Rated Frequency**. The factory setting of the model number only has to be changed if the device is used for a purpose other than the one planned when ordering the device.

Phase Rotation (Power System)

Address 209 **PHASE SEQ.** is used to change the default phase sequence (**A B C** for clockwise rotation), if your power system permanently has an anti-clockwise phase sequence (**A C B**). A temporary reversal of rotation is also possible using binary inputs (see Section 2.15.2).

Temperature Unit (Power System)

Address 276 **TEMP. UNIT** allows displaying the temperature values either in degrees Celsius or in degrees Fahrenheit.

Polarity of Current Transformers (Power System)

At address 201 **CT Starpoint**, the polarity of the wye-connected current transformers is specified (the following figure applies accordingly to two current transformers). This setting determines the measuring direction of the device (forward = line direction). Changing this parameter also results in a polarity reversal of the ground current inputs I_N or I_{NS} .

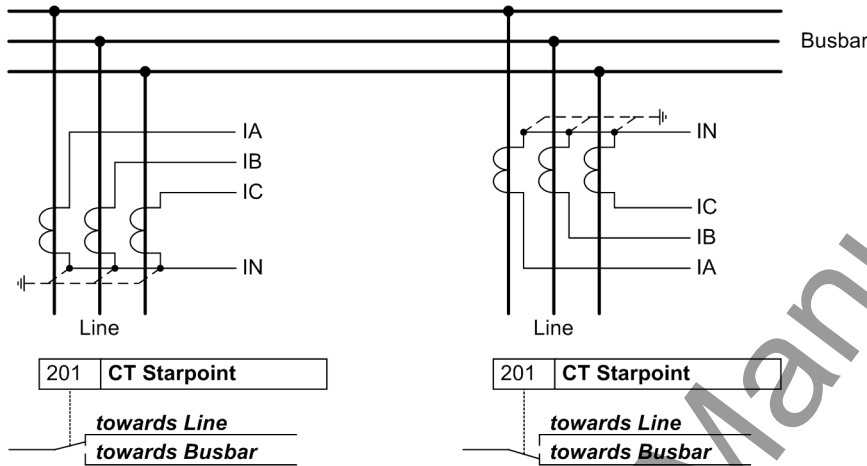

Figure 2-2 Polarity of current transformers

Current Connection I4 (Power System)

Here, the device is informed whether the ground current of the current transformer starpoint is connected to the fourth current input (I_4). This corresponds with the Holmgren-connection, (see connection example in Appendix A.3, Figure A-9). In this case, parameter 280 **Holmgr. for Σi** is set to **YES**. In all other cases, even if the ground current of the own line is measured via a separate ground current transformer, the setting **NO** has to be made. This setting exclusively affects the function „Current Sum Monitoring“ (see Section 2.8.1).

Current Connection (Power System)

Via parameter 251 **CT Connect**, a special connection of the current transformers can be determined.

The standard connection is **A, B, C, (Gnd)**. It may only be changed if the device is set to measure one or more ground currents via two current inputs. The standard connection applies to all other cases.

The following diagram illustrates a special connection.

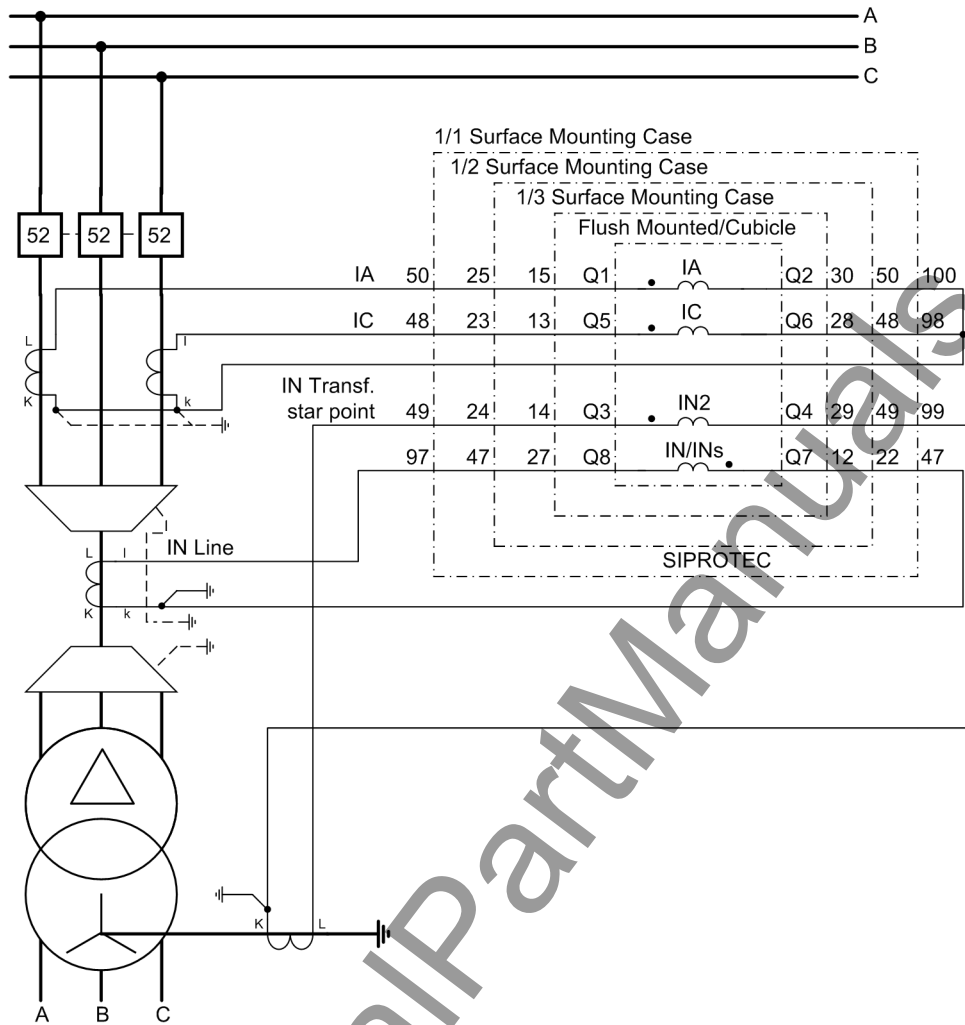

Figure 2-3 Measurement of two ground currents, example

The phase currents I_A and I_C must be connected to the first current input (terminals Q1, Q2) and to the third (terminals Q5, Q6). At the fourth input (terminals Q7, Q8) the ground current I_N or I_{Ns} is connected as usual, in this case the ground current of the line. A second ground current, in this case the transformer starpoint current, is connected to the second current input I_{N2} (terminals Q3, Q4).

The settings **A, G2, C, G; G -> B** or **A, G2, C, G; G2 -> B** must be used here. Both define the connection of a ground current I_{N2} at the second current input (terminals Q3, Q4). The settings only differ in the calculation of I_B . In case of **A, G2, C, G; G -> B**, the phase current I_B is determined by phase currents I_A and I_C as well as the measured ground current I_N or $I_{N\text{ sens}}$ at the fourth current input. In case of **A, G2, C, G; G2 -> B**, the phase current I_B is determined by phase currents I_A and I_C as well as the measured ground current I_{N2} at the second current input. The setting must be set according to system requirements.

The assignment of the protection functions to the ground current inputs in special connections is set out in the following table.

Current Input	function
I_{N2}	Time Overcurrent Protection Ground (Chapter 2.2)
I_N or $I_{N \text{ sensitive}}$	Ground Fault Detection (sensitive / neutral - Chapter 2.9) Single-phase Time Overcurrent Protection (Chapter 2.4) Intermittent Ground Fault Protection (Chapter 2.10)

The settings for address 251 are only possible with DIGSI under **Additional Settings**.



Note

The settings under address 251 **CT Connect**, affect the time overcurrent protection with regard to the evaluation of phase currents only if address 250 **50/51 2-ph prot** has been set to **OFF**.

ATEX100 (Power System)

Parameter 235 **ATEX100** enables meeting the requirements for protecting explosion-protected motors for thermal replicas. Set this parameter to **YES** to save all thermal replicas of the 7SJ61 devices in the event of a power supply failure. After the supply voltage is restored, the thermal replicas will resume operation using the stored values. Set the parameter to **NO**, to reset the calculated overtemperature values of all thermal replicas to zero if the power supply fails.

Nominal Values of Current Transformers (CTs)

At addresses 204 **CT PRIMARY** and 205 **CT SECONDARY** information is entered regarding the primary and secondary ampere ratings of the current transformers. It is important to ensure that the rated secondary current of the current transformer matches the rated current of the device, otherwise the device will calculate incorrect primary data. At addresses 217 **Ignd-CT PRIM** and 218 **Ignd-CT SEC**, information is entered regarding the primary and secondary ampere rating of the current transformer. In case of a normal connection (starpoint current connected to I_G transformer), 217 **Ignd-CT PRIM** and 204 **CT PRIMARY** must be set to the same value.

If the device features a sensitive ground current input, parameter 218 **Ignd-CT SEC** is set to 1 A by default. In this case, the setting cannot be changed.

If address 251 has been set so that ground currents are measured by two inputs (setting options **A, G2, C, G; G->B** or **A, G2, C, G; G2->B**), you have to set the primary rated current of the second ground transformer connected to I_{N2} at address 238. secondary ampere rating must conform with the phase current transformer.

To calculate the phase current I_B correctly, the primary rated current of the ground current transformer, which is used to calculate I_B (address 217 or address 238), must be smaller than the primary rated current of the phase current transformer (address 204).

Trip and Close Command Duration (Breaker)

In address 210 the minimum trip command duration **TMin TRIP CMD** is set. This setting applies to all protection functions that can initiate tripping.

In address 211 the maximum close command duration **TMax CLOSE CMD** is set. It applies to the integrated reclosing function. It must be set long enough to ensure that the circuit breaker has securely closed. An excessive duration causes no problem since the closing command is interrupted in the event another trip is initiated by a protection function.

Current Flow Monitoring (Breaker)

Address 212 **BkrClosed I MIN** corresponds to the threshold value of the integrated current flow monitoring system. This parameter is used by several protection functions (e.g. overload protection and auto-reclosure for motors). If the set threshold current is exceeded, the circuit breaker is considered closed and the power system is considered to be in operation.

The threshold value setting applies to all three phases, and must take into consideration all used protection functions.

The pickup threshold for the circuit-breaker failure protection is set separately (see 2.12.2).

When using the device as motor protection and using the overload protection, load jam protection and restart inhibit, the protective relay can distinguish between a running motor and a stopped motor, as well as take into account the different motor cooldown behavior. For this application, the set value must be lower than the minimum no-load current of the motor.

Circuit-breaker Maintenance (Breaker)

Parameters 260 to 267 are assigned to CB maintenance. The parameters and the different procedures are explained in the setting notes of this function (see Section 2.17.2).

Two-phase Time Overcurrent Protection (Protection Operating Quantities)

The two-phase overcurrent protection functionality is used in grounded or compensated systems where interaction of three-phase devices with existing two-phase protection equipment is required. Via parameter 250 **50/51 2-ph prot** the time overcurrent protection can be configured to two or three-phase operation. If the parameter is set to **ON**, the value 0 A instead of the measured value for I_B is used permanently for the threshold comparison so that no pickup is possible in phase B. All other functions, however, operate in three phases.

Ground Fault Protection (Protection Parameters)

With address 613 **50N/51N/67N w.** you define whether ground fault protection or breaker failure protection is to operate using measured values (**I_{gnd} (measured)**) or the quantities calculated from the three phase currents (**3I₀ (calcul.)**). In the first case, the measured quantity at the fourth current input is evaluated. In the latter case, the summation current is calculated from the three phase current inputs. If the device features a sensitive ground current input (measuring range starts at 1 mA), the ground fault protection always uses the calculated variable 3I₀. In this case, parameter 613 **50N/51N/67N w.** is not available.

2.1.3.3 Settings

Addresses which have an appended "A" can only be changed with DIGSI, under "Display Additional Settings".

The table indicates region-specific default settings. Column C (configuration) indicates the corresponding secondary nominal current of the current transformer.

Addr.	Parameter	C	Setting Options	Default Setting	Comments
201	CT Starpoint		towards Line towards Busbar	towards Line	CT Starpoint
204	CT PRIMARY		10 .. 50000 A	100 A	CT Rated Primary Current
205	CT SECONDARY		1A 5A	1A	CT Rated Secondary Current
209	PHASE SEQ.		A B C A C B	A B C	Phase Sequence
210A	TMin TRIP CMD		0.01 .. 32.00 sec	0.15 sec	Minimum TRIP Command Duration
211A	TMax CLOSE CMD		0.01 .. 32.00 sec	1.00 sec	Maximum Close Command Duration
212	BkrClosed I MIN	1A	0.04 .. 1.00 A	0.04 A	Closed Breaker Min. Current Threshold
		5A	0.20 .. 5.00 A	0.20 A	
214	Rated Frequency		50 Hz 60 Hz	50 Hz	Rated Frequency
217	Ignd-CT PRIM		1 .. 50000 A	60 A	Ignd-CT rated primary current
218	Ignd-CT SEC		1A 5A	1A	Ignd-CT rated secondary current
235A	ATEX100		NO YES	NO	Storage of th. Replicas w/o Power Supply
238	Ignd2-CT PRIM		1 .. 50000 A	60 A	Ignd2-CT rated primary c. (conn. to I2)
250A	50/51 2-ph prot		ON OFF	OFF	50, 51 Time Overcurrent with 2ph. prot.
251A	CT Connect.		A, B, C, (Gnd) A,G2,C,G; G->B A,G2,C,G; G2->B	A, B, C, (Gnd)	CT Connection
260	Ir-52		10 .. 50000 A	125 A	Rated Normal Current (52 Breaker)
261	OP.CYCLES AT Ir		100 .. 1000000	10000	Switching Cycles at Rated Normal Current
262	Isc-52		10 .. 100000 A	25000 A	Rated Short-Circuit Breaking Current
263	OP.CYCLES Isc		1 .. 1000	50	Switch. Cycles at Rated Short-Cir. Curr.
264	Ix EXPONENT		1.0 .. 3.0	2.0	Exponent for the Ix-Method
265	Cmd.via control		(Setting options depend on configuration)	None	52 B.Wear: Open Cmd. via Control Device

Addr.	Parameter	C	Setting Options	Default Setting	Comments
266	T 52 BREAKTIME		1 .. 600 ms	80 ms	Breaktime (52 Breaker)
267	T 52 OPENING		1 .. 500 ms	65 ms	Opening Time (52 Breaker)
276	TEMP. UNIT		Celsius Fahrenheit	Celsius	Unit of temperature measurement
280	Holmgr. for Σi		NO YES	NO	Holmgreen-conn. (for fast sum-i-monit.)
613A	50N/51N/67N w.		Ignd (measured) 3I0 (calcul.)	Ignd (measured)	50N/51N/67N Ground Overcurrent with

2.1.3.4 Information List

No.	Information	Type of Information	Comments
5145	>Reverse Rot.	SP	>Reverse Phase Rotation
5147	Rotation ABC	OUT	Phase rotation ABC
5148	Rotation ACB	OUT	Phase rotation ACB

2.1.4 Oscillographic Fault Records

The Multi-Functional Protection with Control 7SJ61 is equipped with a fault record memory. The instantaneous values of the measured quantities

i_A , i_B , i_C , i_N or i_{Ns}

are sampled at intervals of 1.25 ms (for 50 Hz) or 1.04 ms (for 60 Hz), and stored in a ring buffer (16 samples per cycle). In the case of a fault, the data is recorded for a set period of time, but not for more than 5 seconds. The total duration of recording amounts to up to 20 seconds. Up to 8 fault records can be recorded in this buffer. The fault record memory is automatically updated with every new fault, so that there is no acknowledgment for previously recorded faults required. The fault record buffer can also be started with protection pickup, via binary input, via PC interface, or a serial interface.

2.1.4.1 Description

The data can be retrieved via the serial interfaces by means of a personal computer and evaluated with the protection data processing program DIGSI and the graphic analysis software SIGRA 4. The latter graphically represents the data recorded during the system fault and also calculates additional information from the measured values. Currents can be presented as desired as primary or secondary values. Signals are additionally recorded as binary tracks (marks) e.g. "pickup", "trip".

If the device has a serial system interface, the fault recording data can be passed on to a central device via this interface. The evaluation of data is done by appropriate programs in the central device. Currents are referred to their maximum values, scaled to their rated values and prepared for graphic presentation. Signals are additionally recorded as binary tracks (marks) e.g. "pickup", "trip".

Transfer to a central device can be polled automatically, either after each fault detection by the protection, or only after a trip.



Note

The signals used for binary tracks can be configured in DIGSI.



Note

If via parameter 251 **CT Connect.** one of the current transformer connection types **A, G2, C, G; G->B** or **A, G2, C, G; G2->B** has been selected, the measured ground current I_{N2} measured by the second current transformer is indicated under track „iN“. The ground current detected by the fourth current transformer is indicated under track „iNs“ angezeigt.

2.1.4.2 Setting Notes

Configuration

Fault recording (waveform capture) will only take place if address 104 **OSC. FAULT REC.** is set to **Enabled**. Other settings pertaining to fault recording (waveform capture) are found in the **Osc. Fault Rec.** **OSC. FAULT REC.** submenu of the **SETTINGS** menu. Waveform capture makes a distinction between the trigger instant for an oscillographic record and the criterion to save the record (address 401 **WAVEFORMTRIGGER**). Normally, the trigger is the pickup of a protection element, i.e. the time 0 is defined as the instant the first protection function picks up. The criterion for saving may be both the device pickup (**Save w. Pickup**) or the device trip (**Save w. TRIP**). A trip command issued by the device can also be used as trigger instant (**Start w. TRIP**), in this case it is also the saving criterion.

A fault event starts with the pickup by any protection function and ends when the last pickup of a protection function has dropped out. Usually this is also the extent of a fault recording (address 402 **WAVEFORM DATA = Fault event**). If automatic reclosing is performed, the entire system fault — with several reclosing attempts if necessary — can be recorded until the fault has been cleared for good (address 402 **WAVEFORM DATA = Pow. Sys. Flt.**). This facilitates the representation of the entire system fault history, but also consumes storage capacity during the automatic reclosing dead time(s).

The actual storage time begins at the pre-fault time **PRE. TRIG. TIME** (address 404) ahead of the reference instant, and ends at the post-fault time **POST REC. TIME** (address 405) after the storage criterion has reset. The maximum storage time for each fault recording (**MAX. LENGTH**) is entered in address 403. Recording per fault must not exceed 5 seconds. A total of 8 records can be saved with a total time of 20 seconds at the most.

An oscillographic record can be triggered by a status change of a binary input, or from a PC via the operator interface. Storage is then triggered dynamically. The length of the fault recording is set in address 406 **BinIn CAPT. TIME** (but not longer than **MAX. LENGTH**, address 403). Pre-fault and post-fault times will add to this. If the binary input time is set to ∞ , the length of the record equals the time that the binary input is activated (static), but not longer than the **MAX. LENGTH** (address 403).

2.1.4.3 Settings

Addr.	Parameter	Setting Options	Default Setting	Comments
401	WAVEFORMTRIGGER	Save w. Pickup Save w. TRIP Start w. TRIP	Save w. Pickup	Waveform Capture
402	WAVEFORM DATA	Fault event Pow.Sys.Flt.	Fault event	Scope of Waveform Data
403	MAX. LENGTH	0.30 .. 5.00 sec	2.00 sec	Max. length of a Waveform Capture Record
404	PRE. TRIG. TIME	0.05 .. 0.50 sec	0.25 sec	Captured Waveform Prior to Trigger
405	POST REC. TIME	0.05 .. 0.50 sec	0.10 sec	Captured Waveform after Event
406	BinIn CAPT.TIME	0.10 .. 5.00 sec; ∞	0.50 sec	Capture Time via Binary Input

2.1.4.4 Information List

No.	Information	Type of Information	Comments
-	FltRecSta	IntSP	Fault Recording Start
4	>Trig.Wave.Cap.	SP	>Trigger Waveform Capture
203	Wave. deleted	OUT_Ev	Waveform data deleted
30053	Fault rec. run.	OUT	Fault recording is running

2.1.5 Settings Groups

Up to four different setting groups can be created for establishing the device's function settings.

Applications

- Setting groups enables the user to save the corresponding settings for each application so that they can be quickly called up when required. All setting groups are stored in the device. Only one setting group may be active at a given time.

2.1.5.1 Description

Changing Setting Groups

During operation the user can switch back and forth setting groups locally, via the operator panel, binary inputs (if so configured), the service interface using a personal computer, or via the system interface. For reasons of safety it is not possible to change between setting groups during a power system fault.

A setting group includes the setting values for all functions that have been selected as **Enabled** during configuration (see Section 2.1.1.2). In 7SJ61 relays, four independent setting groups (A to D) are available. While setting values may vary, the selected functions of each setting group remain the same.

2.1.5.2 Setting Notes

General

If setting group change option is not required, Group A is the default selection. Then, the rest of this section is not applicable.

If the changeover option is desired, group changeover must be set to **Grp Chge OPTION = Enabled** (address 103) when the function extent is configured. For the setting of the function parameters, each of the required setting groups A to D (a maximum of 4) must be configured in sequence. The SIPROTEC 4 System Description gives further information on how to copy setting groups or reset them to their status at delivery and also how to change from one setting group to another.

Subsection 3.1 of this manual tells you how to change between several setting groups externally via binary inputs.

2.1.5.3 Settings

Addr.	Parameter	Setting Options	Default Setting	Comments
302	CHANGE	Group A Group B Group C Group D Binary Input Protocol	Group A	Change to Another Setting Group

2.1.5.4 Information List

No.	Information	Type of Information	Comments
-	GroupA act	IntSP	Setting Group A is active
-	GroupB act	IntSP	Setting Group B is active
-	GroupC act	IntSP	Setting Group C is active
-	GroupD act	IntSP	Setting Group D is active
7	>Set Group Bit0	SP	>Setting Group Select Bit 0
8	>Set Group Bit1	SP	>Setting Group Select Bit 1

2.1.6 Power System Data 2

2.1.6.1 Description

The general protection data (P .System Data 2) includes settings associated with all functions rather than a specific protection or monitoring function. In contrast to the P .System Data 1 as discussed before, they can be changed over with the setting groups.

Applications

If the primary reference current of the protected object is set, the device is able to calculate and output the percentage operational measured values.

For protection of motors the motor starting detection represents an important feature. Exceeding a configured current value serves as a criterion.

2.1.6.2 Setting Notes

Definition of Nominal Rated Values

At address 1102 **FullScaleCurr** ., the primary reference current (phase) of the protected equipment is entered (e.g. motors). If this reference variable matches the primary value of the current transformer, it is equivalent to the setting at Address 204 (Section 2.1.3.2). They are generally used to show values as a percentage of full scale.

Recognition of Running Condition (Only for Motors)

When the configured current value at Address 1107 **I MOTOR START** is exceeded, this will be interpreted as motor starting. This parameter is used by the start-up time monitoring and overload protection functions.

For this setting the following should be considered:

- A setting must be selected that is lower than the actual motor start-up current under all load and voltage conditions.
- During motor start-up the thermal replica of the overload protection is "frozen", i.e. kept at a constant level. This threshold should not be set unnecessarily low since it limits the operating range of the overload protection for high currents during operation.

2.1.6.3 Settings

The table indicates region-specific default settings. Column C (configuration) indicates the corresponding secondary nominal current of the current transformer.

Addr.	Parameter	C	Setting Options	Default Setting	Comments
1102	FullScaleCurr.		10 .. 50000 A	100 A	Measur em:FullScaleCur- rent(Equipm.rating)
1107	I MOTOR START	1A	0.40 .. 10.00 A	2.50 A	Motor Start Current (Block 49, Start 48)
		5A	2.00 .. 50.00 A	12.50 A	

2.1.6.4 Information List

No.	Information	Type of In- formation	Comments
126	ProtON/OFF	IntSP	Protection ON/OFF (via system port)
356	>Manual Close	SP	>Manual close signal
501	Relay PICKUP	OUT	Relay PICKUP
511	Relay TRIP	OUT	Relay GENERAL TRIP command
533	Ia =	VI	Primary fault current Ia
534	Ib =	VI	Primary fault current Ib
535	Ic =	VI	Primary fault current Ic
561	Man.Clos.Detect	OUT	Manual close signal detected
2720	>Enable ANSI#-2	SP	>Enable 50/67-(N)-2 (override 79 blk)
4601	>52-a	SP	>52-a contact (OPEN, if bkr is open)
4602	>52-b	SP	>52-b contact (OPEN, if bkr is closed)
16019	>52 Wear start	SP	>52 Breaker Wear Start Criteria
16020	52 WearSet.fail	OUT	52 Wear blocked by Time Setting Failure
16027	52WL.blk I PErr	OUT	52 Breaker Wear Logic blk Ir-CB>=Isc-CB
16028	52WL.blk n PErr	OUT	52 Breaker W.Log.blk SwCyc.Isc>=SwCyc.Ir

2.1.7 EN100-Module

2.1.7.1 Functional Description

The EN100-Module enables integration of the 7SJ61 in 100-Mbit communication networks in control and automation systems with the protocols according to IEC 61850 standard. This standard permits uniform communication of the devices without gateways and protocol converters. Even when installed in heterogeneous environments, SIPROTEC 4 relays therefore provide for open and interoperable operation. Parallel to the process control integration of the device, this interface can also be used for communication with DIGSI and for inter-relay communication via GOOSE.

2.1.7.2 Setting Notes

Interface Selection

No special settings are required for operating the Ethernet system interface module (IEC 1850, **EN100-Module**). If the ordered version of the device is equipped with such a module, it is automatically allocated to the interface available for it, namely **Port B**.

2.1.7.3 Information List

No.	Information	Type of Information	Comments
009.0100	Failure Modul	IntSP	Failure EN100 Modul
009.0101	Fail Ch1	IntSP	Failure EN100 Link Channel 1 (Ch1)
009.0102	Fail Ch2	IntSP	Failure EN100 Link Channel 2 (Ch2)

2.2 Overcurrent Protection 50, 51, 50N, 51N

Overcurrent protection is the main protection function of the 7SJ61 relay. Each phase current and the ground current is provided with four elements. All elements are independent from each other and can be combined as desired.

If it is desired in grounded or compensated systems that three-phase devices should work together with two-phase protection equipment, the overcurrent protection can be configured in such a way that it allows twophase operation besides three-phase mode (see Section 2.1.3.2).

The high-set elements 50-3 and 50-2 as well as the overcurrent element 50-1 always operate with definite tripping time, the fourth element 51 always with inverse tripping time.

Applications

- The non-directional overcurrent protection is suited for networks that are radial and supplied from a single source or open looped networks, for backup protection of differential protective schemes of all types of lines, transformers, generators, motors, and busbars.

2.2.1 General

Depending on parameter 613 **50N/51N/67N w.** the overcurrent protection for the ground current can either operate with measured values I_N or with the quantities $3I_0$ calculated from the three phase currents. Devices featuring a sensitive ground current input, however, generally use the calculated quantity $3I_0$.

All overcurrent elements enabled in the device may be blocked via the automatic reclosing function (depending on the cycle) or via an external signal to the binary inputs of the device. Removal of blocking during pickup will restart time delays. The Manual Close signal is an exception. If a circuit breaker is manually closed onto a fault, it can be re-opened immediately. For overcurrent or high-set elements the delay may be bypassed via a Manual Close pulse, thus resulting in high speed tripping. This pulse is extended up to at least 300 ms.

The automatic reclosure function 79 may also initiate immediate tripping for the overcurrent and high-set elements depending on the cycle.

Pickup of the definite-time elements can be stabilized by setting the dropout times. This protection comes into use in systems where intermittent faults occur. Combined with electromechanical relays, it allows different dropout responses to be adjusted and a time grading of digital and electromechanical relays to be implemented.

Pickup and delay settings may be quickly adapted to system requirements via dynamic setting changeover (see Section 2.3).

Tripping by the 50-1 and 51 elements (in phases), 50N-1 and 51N elements (in ground path) may be blocked for inrush conditions by utilizing the inrush restraint feature. 4

The following table gives an overview of the interconnection to other functions of 7SJ61.

Table 2-1 Interconnection to other functions

Overcurrent Elements	Connection to	Manual CLOSE	Dynamic Cold Load Pickup	Inrush Restraint Restraint
50-1	•	•	•	•
50-2	•	•	•	•
50-3	•	•	•	•
51	•	•	•	•
50N-1	•	•	•	•
50N-2	•	•	•	•
50N-3	•	•	•	•
51N	•	•	•	•

2.2.2 Definite Time, High-set Elements 50-3, 50-2, 50N-3, 50N-2

For each element an individual pickup value **50-3 PICKUP**, **50-2 PICKUP** or **50N-3 PICKUP**, **50N-2 PICKUP** is set. For **50-3 PICKUP** and **50N-3 PICKUP**, apart from *Fundamental* and *True RMS*, the *Instantaneous* values can also be measured. Each phase and ground current is compared separately per element with the common pickup values **50-3 PICKUP**, **50-2 PICKUP** or **50N-3 PICKUP**, **50N-2 PICKUP**. If the respective pickup value is exceeded, this is signaled. After the user-defined time delays **50-3 DELAY**, **50-2 DELAY** or **50N-3 DELAY**, **50N-2 DELAY** have elapsed, trip signals are issued which are available for each element. The dropout value is roughly equal to 95% of the pickup value for currents $> 0.3 I_{Nom}$. If the measurement of the instantaneous values has been configured for the 50-3 or 50N-3 element, the dropout ratio amounts to 90 %.

Pickup can be stabilized by setting dropout times **1215 50 T DROP-OUT** or **1315 50N T DROP-OUT**. This time is started and maintains the pickup condition if the current falls below the threshold. Therefore, the function does not drop out at high speed. The trip delay time **50-3 DELAY**, **50-2 DELAY** or **50N-3 DELAY**, **50N-2 DELAY** continues running in the meantime. After the dropout delay time has elapsed, the pickup is reported OFF and the trip delay time is reset unless the threshold **50-3 PICKUP**, **50-2 PICKUP** or **50N-3 PICKUP**, **50N-2 PICKUP** has been exceeded again. If the threshold is exceeded again during the dropout delay time, the time is cancelled. The trip delay time **50-3 DELAY**, **50-2 DELAY** or **50N-3 DELAY**, **50N-2 DELAY** continues running in the meantime. If the threshold value is exceeded after its expiry, the trip command is issued immediately. If the threshold value is not exceeded at this time, there is no reaction. If the threshold value is exceeded again after expiry of the trip-command delay time, while the dropout delay time is still running, tripping occurs immediately.

These elements can be blocked by the automatic reclosing feature (79 AR).

The following figures give an example of logic diagrams for the high-set elements **50-2 PICKUP** or **50N-2 PICKUP**. They also apply analogously to the high-set elements **50-3 PICKUP** and **50N-3 PICKUP**.

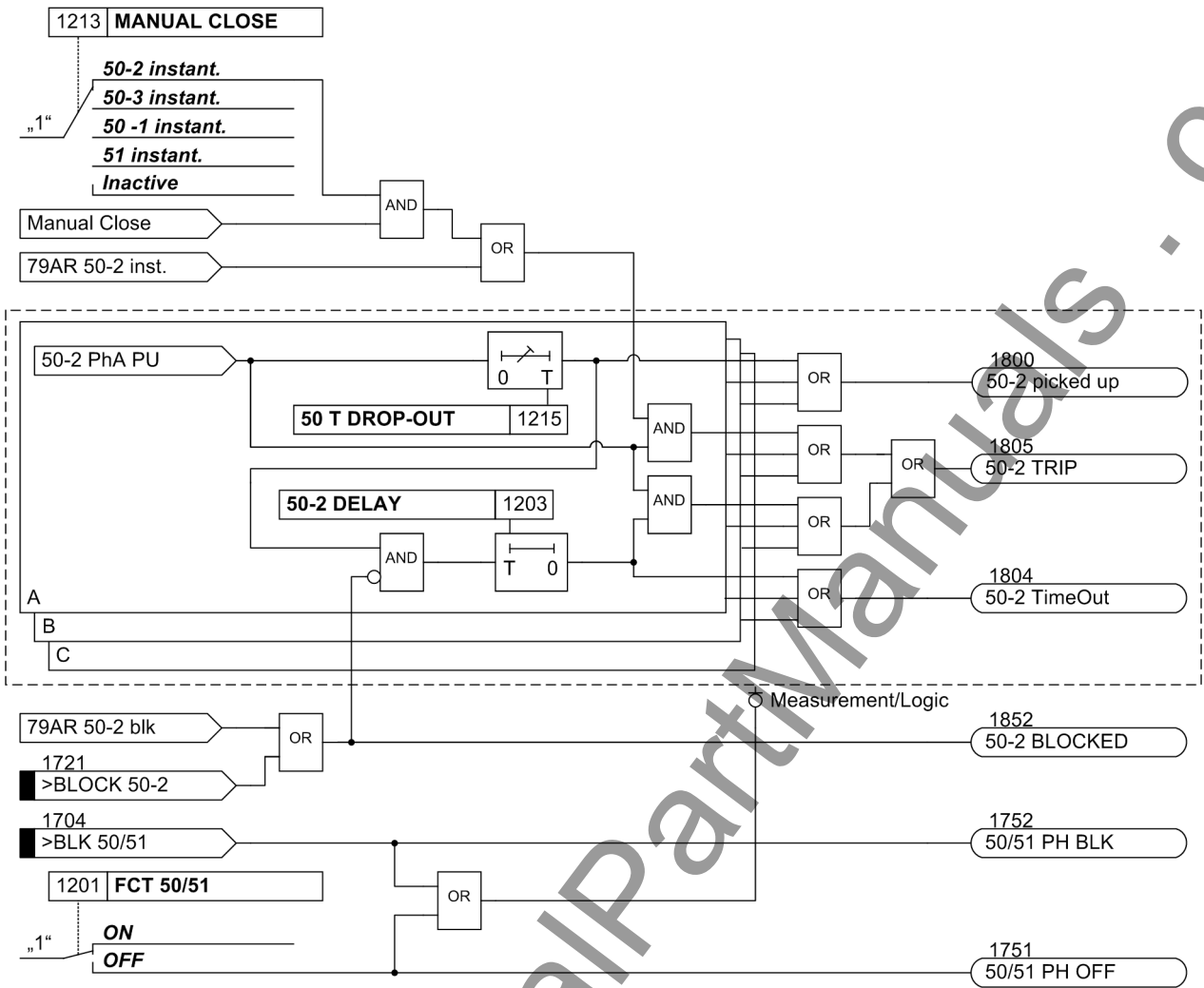

Figure 2-4 Logic diagram for 50-2 for phases

If parameter **MANUAL CLOSE** is set to **50-2 instant.** or **50-3 instant.** and manual close detection is used, a pickup causes instantaneous tripping, even if the element is blocked via binary input. The same applies to 79AR 50-2 inst.

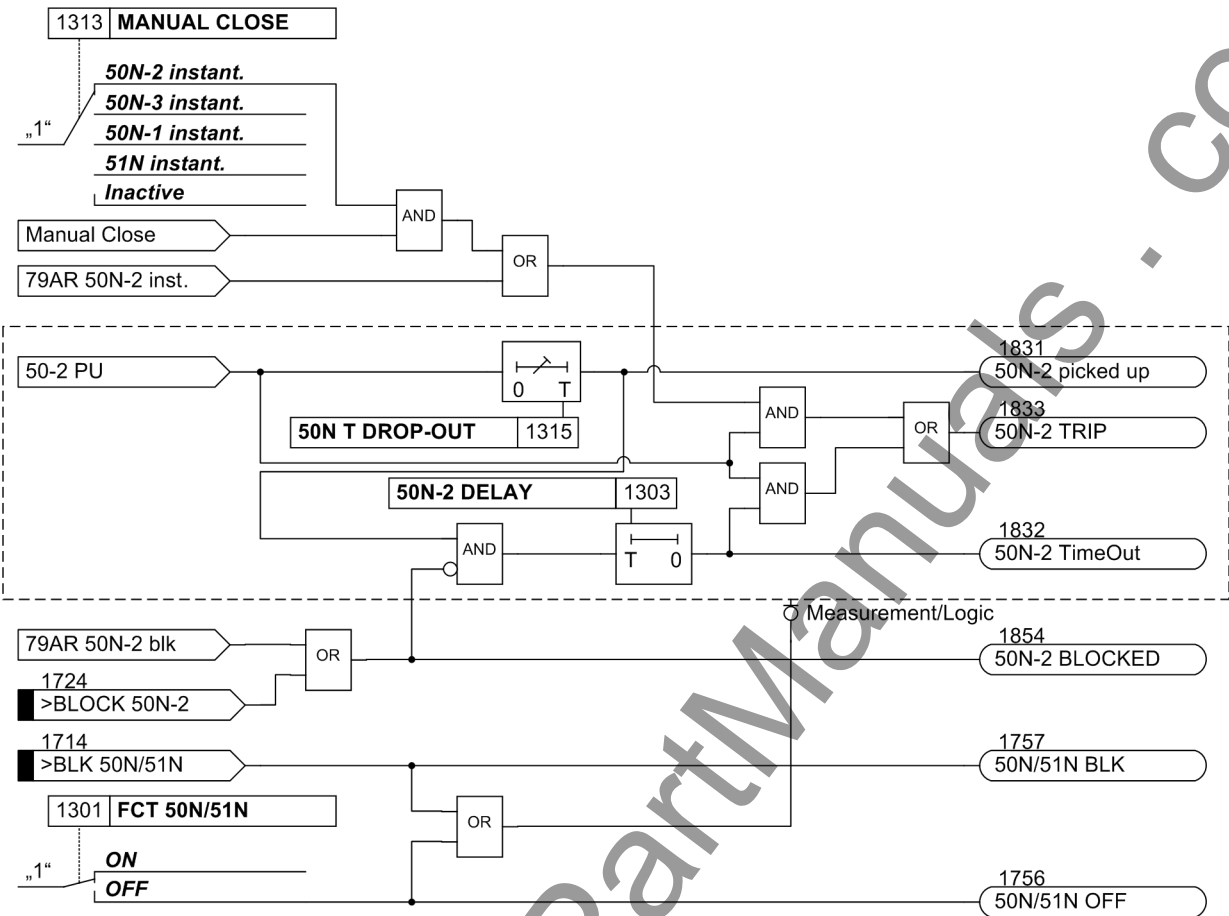

Figure 2-5 Logic diagram for 50N-2 high-set element

If parameter **MANUAL CLOSE** is set to **50N-2 instant.** or **50N-3 instant.** and manual close detection is used, a pickup causes instantaneous tripping, even if the element is blocked via binary input. The same applies to AR 50N-2 inst.

2.2.3 Definite Time Overcurrent Elements 50-1, 50N-1

For each element an individual pickup value **50-1 PICKUP** or **50N-1 PICKUP** is set. Apart from *Fundamental1*, the *True RMS* can also be measured. Each phase and ground current is compared separately with the setting value 50-1 or 50N-1 for each element. If the respective value is exceeded, this is signaled. If the inrush restraint feature (see below) is applied, either the normal pickup signals or the corresponding inrush signals are output as long as inrush current is detected. After user-configured time delays **50-1 DELAY** or **50N-1 DELAY** have elapsed, a trip signal is issued if no inrush current is detected or inrush restraint is disabled. If the inrush restraint feature is enabled and an inrush condition exists, no tripping takes place but a message is recorded and displayed indicating when the overcurrent element time delay elapses. Trip signals and signals on the expiration of time delay are available separately for each element. The dropout value is approximately 95% of the pickup value for currents $> 0.3 I_{Nom}$.

Pickup can be stabilized by setting dropout times 1215 **50 T DROP-OUT** or 1315 **50N T DROP-OUT**. This time is started and maintains the pickup condition if the current falls below the threshold. Therefore, the function does not drop out at high speed. The trip-command delay time **50-1 DELAY** or **50N-1 DELAY** continues running in the meantime. After the dropout delay time has elapsed, the pickup is reported OFF and the trip delay time is reset unless the threshold 50-1 or 50N-1 has been exceeded again. If the threshold is exceeded again during the dropout delay time, the time is cancelled. However, the trip-command delay time **50-1 DELAY** or **50N-1 DELAY** continues running. If the threshold value is exceeded after its expiry, the trip command is issued immediately. If the threshold value is not exceeded at this time, there is no reaction. If the threshold value is exceeded again after expiry of the trip-command delay time, while the dropout delay time is still running, tripping occurs immediately.

Pickup stabilization of the overcurrent elements 50-1 or 50N-1 by means of settable dropout time is deactivated if an inrush pickup is present since an inrush does not represent an intermittent fault.

These elements can be blocked by the automatic reclosing feature (79 AR).

The following figures show the logic diagrams for the current elements 50-1 and 50N-1.

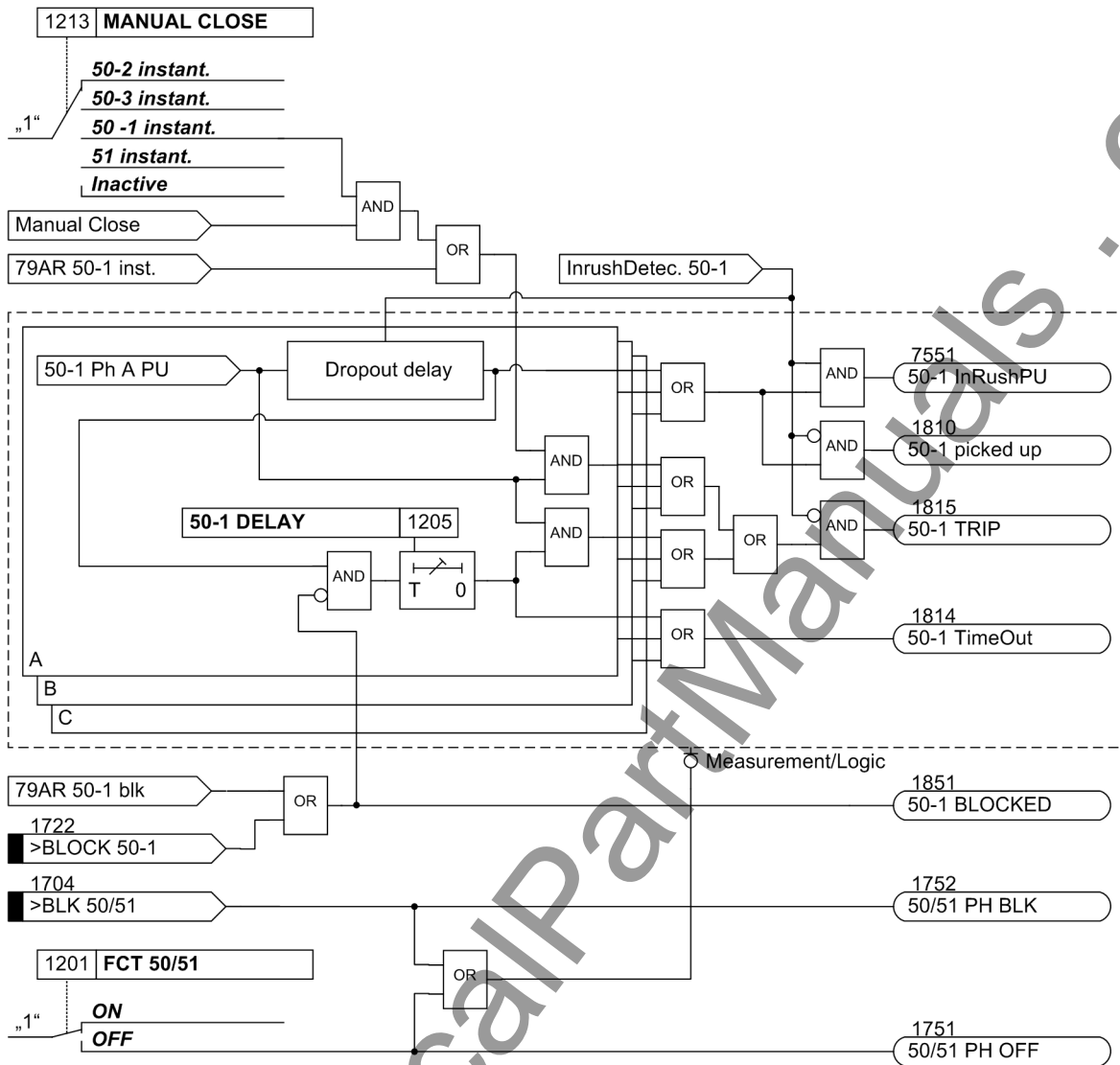

Figure 2-6 Logic diagram for the 50-1 current element for phases

The dropout delay only operates if no inrush was detected. An incoming inrush will reset a running dropout delay time.

If parameter **MANUAL CLOSE** is set to **50 -1 instant.** and manual close detection is used, a pickup causes instantaneous tripping, even if blocking of the element via binary input is present. The same applies to 79AR 50-1 inst.

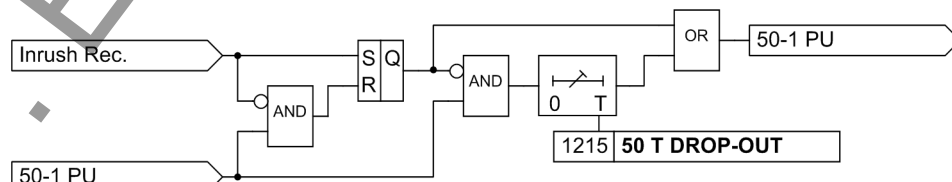

Figure 2-7 Logic diagram of the dropout delay for 50-1

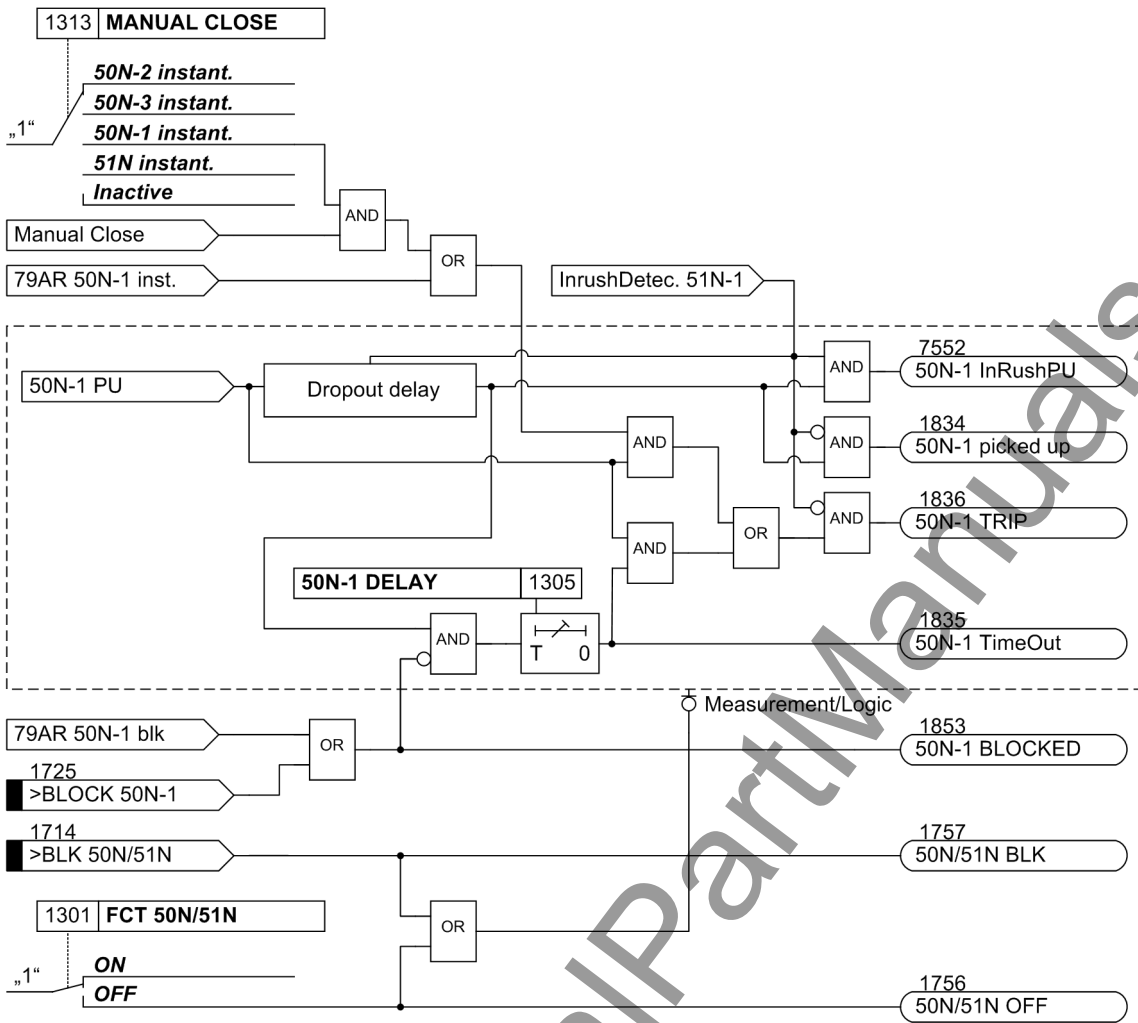

Figure 2-8 Logic diagram for the 50N-1 current element

If parameter **MANUAL CLOSE** is set to **50N-1 instant.** and manual close detection applies, the trip is initiated as soon as the pickup conditions arrive, even if the element is blocked via a binary input. The same applies to 79 AR 50N-1 inst.

The pickup values of each 50-1, 50-2 element for the phase currents and 50N-1, 50N-2 element for the ground current and the valid delay times for each element can be set individually.

The dropout delay only functions if no inrush was detected. An incoming inrush will reset a running dropout time delay.

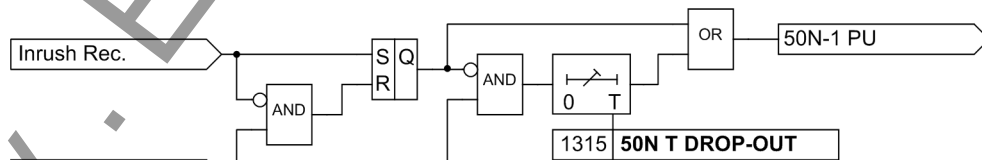

Figure 2-9 Logic of the dropout delay for 50N-1

2.2.4 Inverse Time Overcurrent Elements 51, 51N

Inverse time elements are dependent on the variant ordered. They operate with an inverse time characteristic either according to the IEC- or the ANSI-standard or with a user-defined characteristic. The characteristics and associated formulas are given in the Technical Data.

During configuration of the inverse time curves, the definite time relay elements 50-3, 50-2 and 50-1 are also enabled (see Section "Definite Time High-set Elements 50-3, 50-2, 50N-3, 50N-2" and "Definite Time Overcurrent Elements 50-1, 50N-1").

Pickup Behavior

For each element an individual pickup value **51 PICKUP** or **51N PICKUP** is set. Apart from **Fundamental**, the **True RMS** can also be measured. Each phase and ground current is separately compared with the setting value 51 or 51N per element. If a current exceeds 1.1 times the setting value, the corresponding element picks up and is signaled individually. If the inrush restraint feature is used, either the normal pickup signals or the corresponding inrush signals are issued as long as inrush current is detected. If the 51 element picks up, the tripping time is calculated from the actual fault current flowing, using an integrating method of measurement. The calculated tripping time depends on the selected tripping curve. Once this time has elapsed, a trip signal is issued provided that no inrush current is detected or inrush restraint is disabled. If the inrush restraint feature is enabled and an inrush condition exists, no tripping takes place but a message is recorded and displayed indicating when the overcurrent element time delay elapses.

These elements can be blocked by the automatic reclosing feature (79 AR).

For ground current element 51N the characteristic may be selected independently of the characteristic used for phase currents.

Pickup values of elements 51 (phase currents) and 51N (ground current) and the relevant time multipliers may be set individually.

The following two figures show the logic diagrams for the inverse time overcurrent protection.

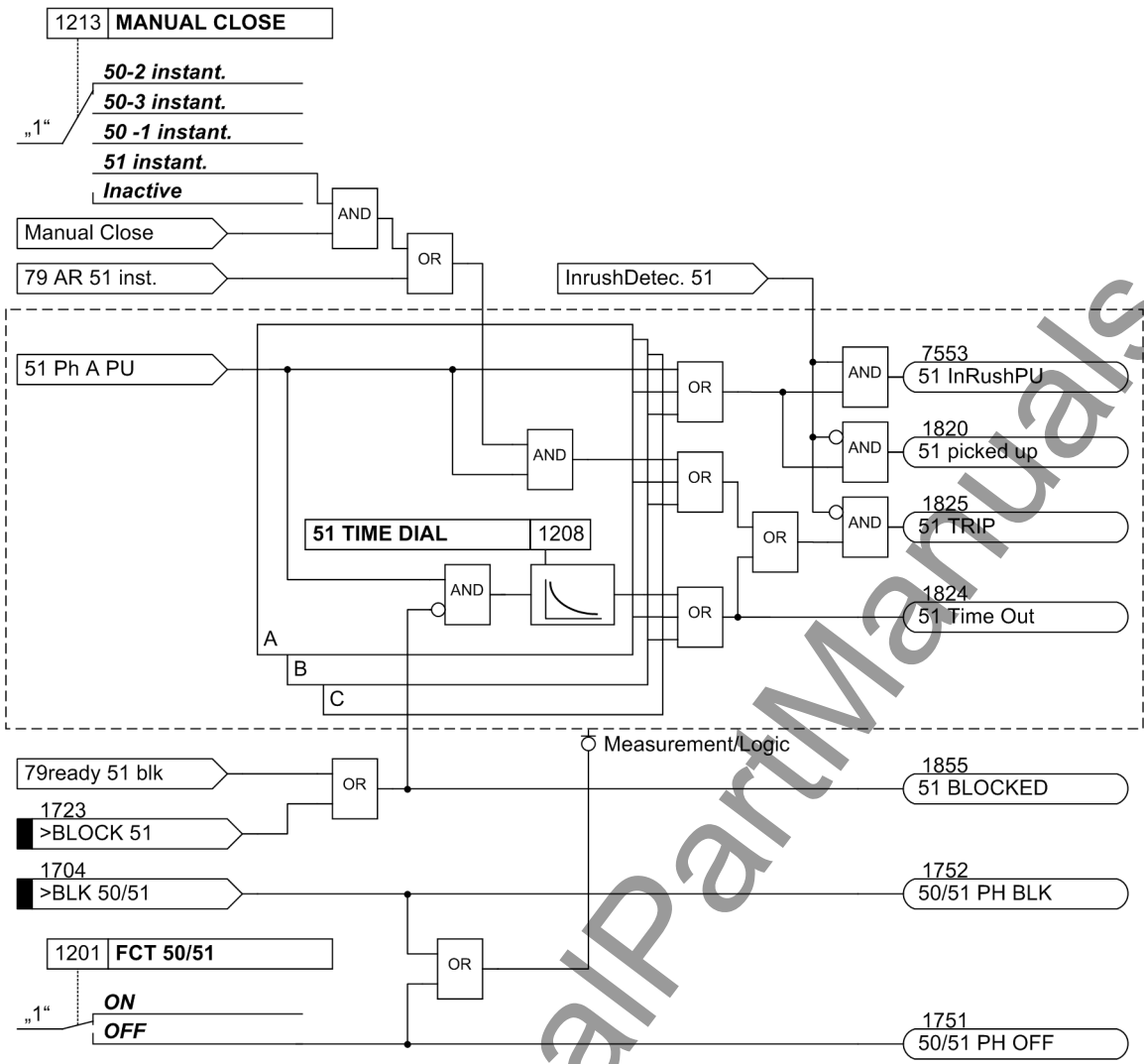

Figure 2-10 Logic diagram of the inverse-time overcurrent protection element for phases

If parameter **MANUAL CLOSE** is set to **51 instant.** and manual close detection applies, the trip is initiated as soon as the pickup conditions arrive, even if the element is blocked via a binary input. The same applies to 79AR 51 inst.

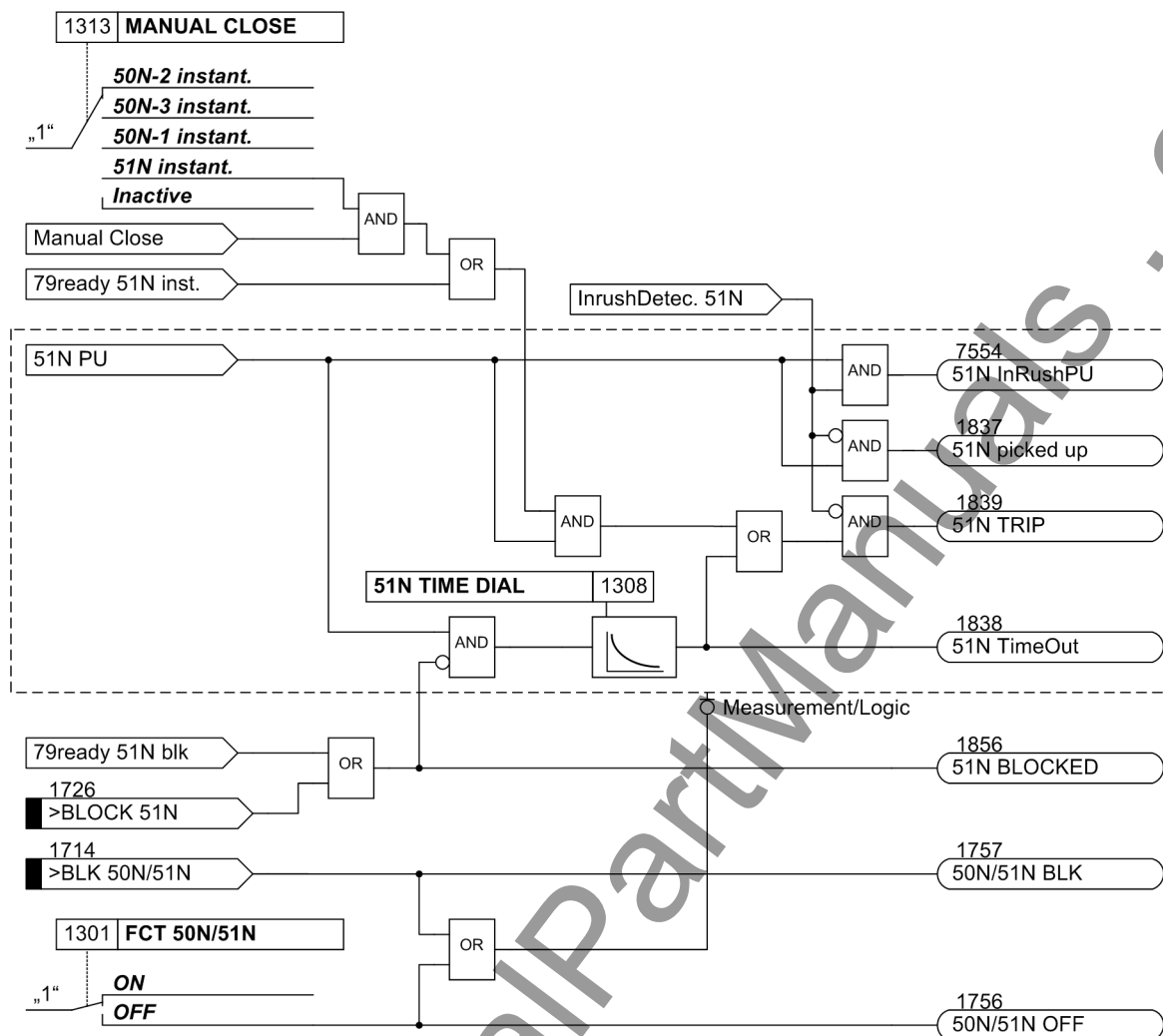

Figure 2-11 Logic diagram of the inverse-time overcurrent protection element for ground

If parameter **MANUAL CLOSE** is set to **51N instant.** and manual close detection applies, the trip is initiated as soon as the pickup conditions arrive, even if the element is blocked via binary input. The same applies to 79AR 51N inst.

Dropout Behavior

When using an ANSI or a IEC curve, it can be selected whether the dropout of an element is to occur instantaneously after the threshold has been undershot or whether dropout is to be performed by means of disk emulation. "Instantaneous" means that pickup drops off when 95 % of the pickup value is undershot. For a new pickup the time delay starts at zero.

The disk emulation evokes a dropout process (timer counter is decrementing) which begins after de-energization. This process corresponds to the reset of a Ferraris-disk (explaining its denomination "disk emulation"). In case several faults occur in succession, the "history" is taken into consideration due to the inertia of the Ferraris-disk and the time response is adapted. Reset begins as soon as 90 % of the setting value is undershot, in accordance with the dropout curve of the selected characteristic. In the range between the dropout value (95 % of the pickup value) and 90 % of the setting value, the incrementing and the decrementing processes are in idle state.

Disk emulation offers advantages when the overcurrent relay elements must be coordinated with conventional electromechanical overcurrent relays located towards the source.

User-defined Characteristics

When user-defined characteristic are used, the tripping curve may be defined point by point. Up to 20 value pairs (current, time) may be entered. The device then approximates the characteristic, using linear interpolation.

The dropout curve may be user-defined as well. See dropout behavior for ANSI and IEC curves in the function description. If no user-defined dropout curve is required, the element drops out as soon as the respective current falls below approx. 95% of the set pickup value. When a new pickup is evoked, the timer starts at zero again.

2.2.5 Dynamic Cold Load Pickup Function

It may be necessary to dynamically increase the pickup values if, during starting, certain elements of the system show an increased power consumption after a long period of zero voltage (e.g. air-conditioning systems, heating installations, motors). Thus, a general raise of pickup thresholds can be avoided taking such starting conditions into consideration.

This dynamic pickup value changeover is common to all overcurrent elements and is described in Section 2.3. The alternative pickup values can be set individually for each element of the time overcurrent protection.

2.2.6 Inrush Restraint

If the multi-functional protective relay 7SJ61 is installed, for instance, to protect a power transformer, large magnetizing inrush currents will flow when the transformer is energized. These inrush currents may be several times the nominal transformer current, and, depending on the transformer size and design, may last from several milliseconds to several seconds.

Although pickup of the relay elements is based only on the fundamental harmonic component of the measured currents, false device pickup due to inrush is still a potential problem since, depending on the transformer size and design, the inrush current also comprises a large component of the fundamental.

7SJ61 features an integrated inrush restraint function. It prevents the „normal“ pickup of 50-1 or 51 relay elements (not 50-2 and 50-3) in the phases and the ground path of the overcurrent relay elements. The same is true for the alternative pickup thresholds of the dynamic cold load pickup function. After detection of inrush currents above a pickup value, special inrush signals are generated. These signals also initiate fault annunciations and start the associated trip delay time. If inrush conditions are still present after the tripping time delay has elapsed, a corresponding message („...Timeout“) is output, but the overcurrent tripping is blocked (see also logic diagrams of time overcurrent elements, Figures 2-6 to 2-11).

Inrush current contains a relatively large second harmonic component (twice the nominal frequency) which is nearly absent during a fault current. The inrush restraint is based on the evaluation of the 2nd harmonic present in the inrush current. For frequency analysis, numerical filters are used to conduct a Fourier analysis of all three phase currents and the ground current.

Inrush current is recognized, if the following conditions are fulfilled at the same time:

- The harmonic content is larger than the setting value 2202 **2nd HARMONIC** (minimum $0.025 * I_{Nom,sec}$);
- the currents do not exceed an upper limit value 2205 **I Max**;
- the current of the affected element has exceeded the pickup value.

In this case, an inrush in the affected phase is recognized (annunciations 1840 to 1842 and 7558 „InRush Gnd Det“, see figure 2-12) and its blocking being carried out.

Since quantitative analysis of the harmonic components cannot be completed until a full line period has been measured, pickup will generally be blocked by then. Therefore, assuming the inrush restraint feature is enabled, a pickup message will be delayed by a full line period if no closing process is present. On the other hand, trip delay times of the time overcurrent protection feature are started immediately even with the inrush restraint being enabled. Time delays continue running with inrush currents present. If inrush blocking drops out after the time delay has elapsed, tripping will occur immediately. Therefore, utilization of the inrush restraint feature will not result in any additional tripping delays. If a relay element drops out during inrush blocking, the associated time delay will reset.

Cross Blocking

Since inrush restraint operates individually for each phase, protection is ideal where a power transformer is energized into a single-phase fault and inrush currents are detected on a different healthy phase. However, the protection feature can be configured to allow that not only this phase element but also the remaining elements (including ground) are blocked (the so-called **CROSS BLOCK** function, address 2203) if the permissible harmonic component of the current is exceeded for only one phase.

Please take into consideration that inrush currents flowing in the ground path will not cross-block tripping by the phase elements.

Cross blocking is reset if there is no more inrush in any phase. Furthermore, the cross blocking function may also be limited to a particular time interval (address 2204 **CROSS BLK TIMER**). After expiry of this time interval, the cross blocking function will be disabled, even if inrush current is still present.

The inrush restraint has an upper limit: Above this (via adjustable parameter 2205 **I Max**) current blocking is suppressed since a high-current fault is assumed in this case.

The following figure shows the inrush restraint influence on the time overcurrent elements including cross-blocking.

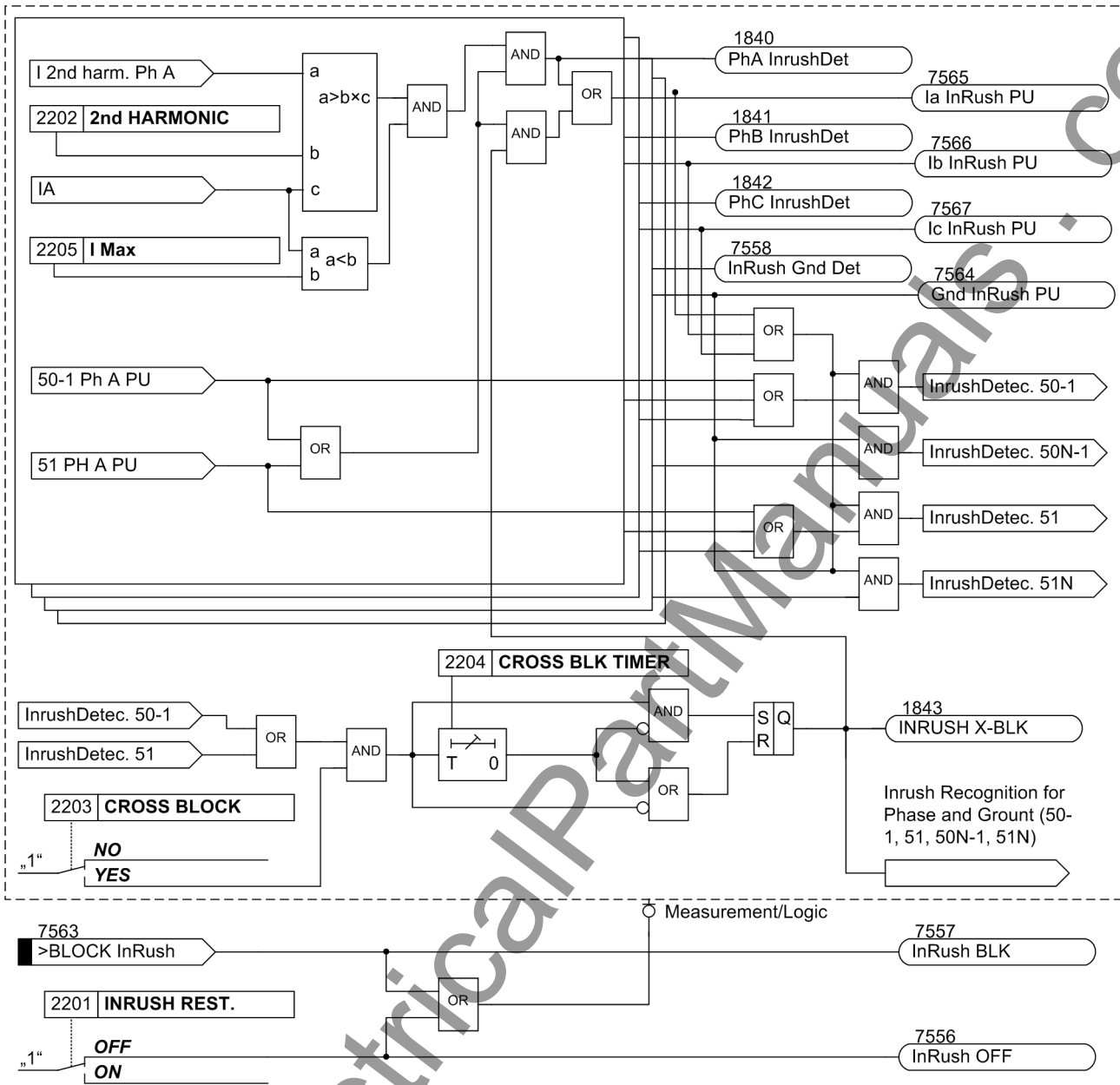

Figure 2-12 Logic diagram for inrush restraint

2.2.7 Pickup Logic and Tripping Logic

The pickup annunciations of the individual phases (or ground) and the individual elements are combined with each other in such a way that the phase information and the element that has picked up are issued.

Table 2-2 Pickup annunciations of the overcurrent protection

Internal Annunciation	Display	Output Annunciation	FNo.
50-3 A PU 50-2 A PU 50-1 A PU 51 A PU	2-4 2-6 2-10	„50/51 Ph A PU“	1762
50-3 B PU 50-2 B PU 50-1 B PU 51 B PU	2-4 2-6 2-10	„50/51 Ph B PU“	1763
50-3 C PU 50-2 C PU 50-1 C PU 51 C PU	2-4 2-6 2-10	„50/51 Ph C PU“	1764
50N-3 PU 50N-2 PU 50N-1 PU 51N PU	2-5 2-8 2-11	„50N/51NPickedup“	1765
50-3 A PU 50-3 B PU 50-3 C PU 50N-3 PU		„50-3 picked up“	1767
50-2 A PU 50-2 B PU 50-2 C PU 50N-2 PU	2-4 2-4 2-4 2-5	„50-2 picked up“	1800
50-1 C PU 50-1 B PU 50-1 A PU 50N-1 PU	2-6 2-6 2-6 2-5	„50-1 picked up“	1810
51 PU A 51 PU B 51 PU C 51N PU	2-10 2-10 2-10 2-11	„51 picked up“	1820
(All pickups)		„50(N)/51(N) PU“	1761

In the trip signals, the element which initiated the tripping is also indicated.

2.2.8 Two-phase Time Overcurrent Protection

The two-phase overcurrent protection functionality is used in grounded or compensated systems where interaction with existing two-phase protection equipment is required. As an isolated or resonant-grounded system remains operational with a single-phase ground fault, this protection serves the purpose of detecting double ground faults with high ground fault currents. Only then must the respective feeder be switched off. A two-phase measurement is sufficient for this purpose. In order to ensure selectivity of the protection in this section of the system, only phases A and C are monitored.

If 250 **50/51 2-ph prot** (settable in **P.System Data 1**) is set to **ON**, I_B is not used for threshold comparison. If the fault is a simple ground fault in B, the element will not pick up. Only after pickup on A or C a double ground fault is assumed, causing the element to pick up and trip after the delay time has elapsed.



Note

With inrush recognition activated and inrush only on B, no cross blocking will take place in the other phases. On the other hand, if inrush with cross blocking is activated on A or C, B will also be blocked.

2.2.9 Fast Busbar Protection Using Reverse Interlocking

Application Example

Each of the overcurrent elements can be blocked via binary inputs of the relay. A setting parameter determines whether the binary input operates in the normally open (i.e. actuated when energized) or the normally closed (i.e. actuated when de-energized) mode. This allows, for example, the busbar protection to take immediate effect in star systems or looped systems which are open on one side, utilizing "reverse interlocking". This principle is often used, for example, in distribution systems, auxiliary systems of power plants, and the like, where a station supply transformer supplied from the transmission grid serves internal loads of the generation station via a medium voltage bus with multiple feeders (Figure 2-13).

The reverse interlocking principle is based on the following: Time overcurrent protection of the busbar feeder trips with a short time delay T 50-2 independent of the grading times of the feeders, unless the pickup of the next load-side overcurrent protection element blocks the busbar protection (Figure 2-13). Always the protection element nearest to the fault will trip with the short time delay since this element cannot be blocked by a protection element located behind the fault. Time elements T 50-1 or T51 are still effective as backup element. Pickup signals output by the load-side protective relay are used as input message „>BLOCK 50-2“ via a binary input at the feeder-side protective relay.

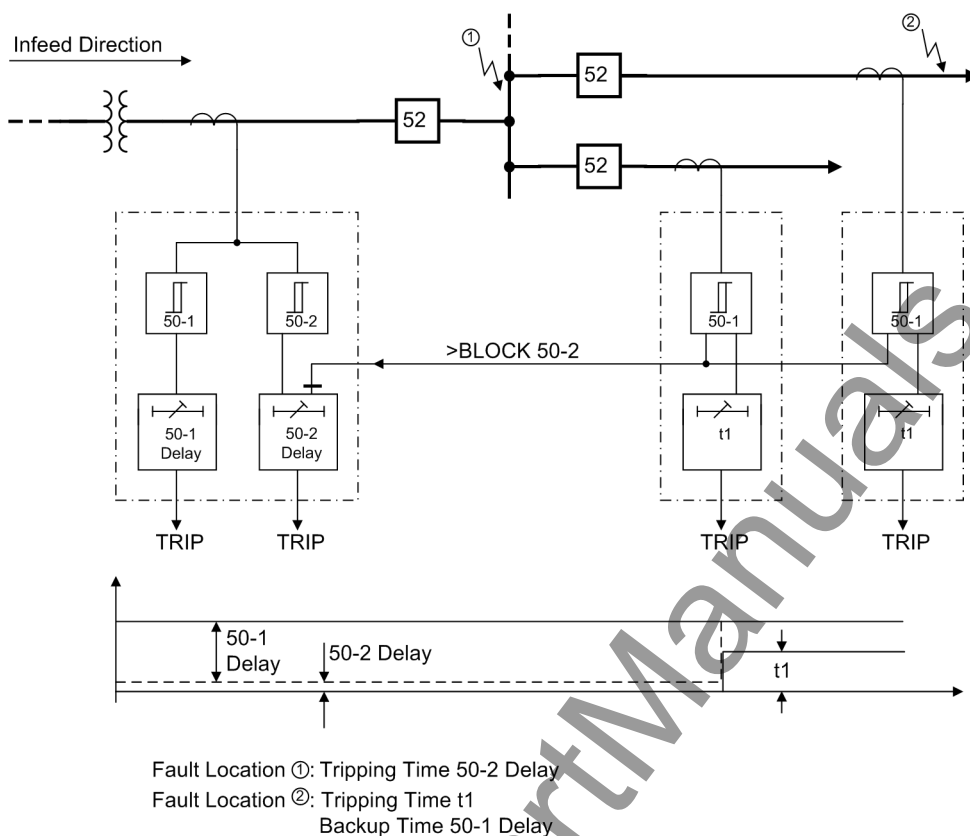

Figure 2-13 Reverse interlocking protection scheme

2.2.10 Setting Notes

General

When selecting the time overcurrent protection in DIGSI a dialog box appears with several tabs, such as , , , and in which the individual parameters can be set. Depending on the functional scope specified during configuration of the protective functions in addresses 112 **Charac. Phase** and 113 **Charac. Ground** the number of tabs can vary. If address **FCT 50/51** was set to **Definite Time**, or **Charac. Ground** was set to **Definite Time**, then only the settings for the definite time elements are available. The selection of **TOC IEC** or **TOC ANSI** makes additional inverse characteristics available. The superimposed high-set elements 50-2, 50-3 and 50N-2, 50N-3 are available in all these cases.

Parameter 250 **50/51 2-ph prot** can also be set to activate two-phase overcurrent protection.

Under address 1201 **FCT 50/51**, overcurrent protection for phases and under address 1301 **FCT 50N/51N**, the ground overcurrent protection can be switched **ON** or **OFF**.

Pickup values, time delays, and characteristics for ground protection are set separately from the pickup values, time delays and characteristic curves associated with phase protection. Because of this, relay coordination for ground faults is independent of relay coordination for phase faults, and more sensitive settings can often be applied to directional ground protection.

Depending on the setting of parameter 251 **CT Connect.**, the device can also be used in specific system constellations with regard to current connections. Further information can be found under Section 2.1.3.2, "Current Connections".

Measurement Methods

The comparison values to be used for the respective element can be set in the setting sheets for the elements.

- Measurement of the **fundamental harmonic** (standard method):

This measurement method processes the sampled values of the current and filters in numerical order the fundamental harmonic so that the higher harmonics or transient peak currents remain largely unconsidered.

- Measurement of the **true r.m.s. value**

The current amplitude is derived from the sampled values in accordance with the definition equation of the true r.m.s. value. This measurement method should be selected when higher harmonics are to be considered by the function (e.g. in capacitor banks).

- Measurement with **instantaneous values**

This method compares the instantaneous values to the set threshold. It does not perform a mean-value calculation and is thus sensitive with regard to disturbances. This measurement method should only be selected if an especially short pickup time of the element is required. With this measurement method, the operating time of the element is reduced compared to the measurement of true r.m.s. values or fundamental harmonics (see "Technical Data").

The type of the comparison values can be set under the following addresses:

50-3 element	Address 1219 50-3 measurement.
50-2 element	Address 1220 50-2 measurement.
50-1 element	Address 1221 50-1 measurement.
51 element	Address 1222 51 measurement.
50N-3 element	Address 1319 50N-3 measurement.
50N-2 element	Address 1320 50N-2 measurement.
50N-1 element	Address 1321 50N-1 measurement.
51N element	Address 1322 51N measurement.

High-set Current Elements 50-2, 50-3 (phases)

The pickup currents of the high-set elements **50-2 PICKUP** or **50-3 PICKUP** can be set either at address 1202 or 1217. The corresponding delay time **50-2 DELAY** or **50-3 DELAY** can be configured under address 1203 or 1218. It is usually used for purposes of current grading intended for large impedances that are prevalent in transformers or generators. It is specified in such manner that it picks up faults up to this impedance.

Example of the high-set current element **50-2 PICKUP**: Transformer used for busbar supply with the following data:

Rated power of the transformer	$S_{NomT} = 16 \text{ MVA}$
Transformer impedance	$ZTX = 10 \%$
Primary nominal voltage	$V_{Nom1} = 110 \text{ kV}$
Secondary nominal voltage	$V_{Nom2} = 20 \text{ kV}$
Vector groups	Dy 5
Starpoint	Grounded
Fault power on 110 kV-side	1 GVA

Based on the data above, the following fault currents are calculated:

3-Phase High Voltage Side Fault Current	at 110 kV = 5250 A
3-Phase Low Voltage Side Fault Current	at 20 kV = 3928 A
On the High Voltage Side Flowing	at 110 kV = 714 A

The nominal current of the transformer is:

$I_{\text{NomT}, 110} = 84 \text{ A}$ (High Voltage Side)	$I_{\text{NomT}, 20} = 462 \text{ A}$ (Low Voltage Side)
Current Transformer (High Voltage Side)	100 A / 1 A
Current Transformer (Low Voltage Side)	500 A / 1 A

Due to the following definition

$$\text{High-set Element 50-2 PICKUP} \quad \frac{50-2}{I_{\text{Nom}}} > \frac{1}{V_{\text{kTransf}}} \cdot \frac{I_{\text{NomTransf}}}{I_{\text{NomCT}}}$$

the following setting applies to the protection device: The 50-2 high-set current element must be set higher than the maximum fault current which is detected during a low side fault on the high side. To reduce fault probability as much as possible even when fault power varies, the following setting is selected in primary values: $50-2 / I_{\text{Nom}} = 10$, i.e. $50-2 = 1000 \text{ A}$. The same applies analogously when using the high-set element 50-3.

Increased inrush currents, if their fundamental component exceeds the setting value, are rendered harmless by delay times (address 1203 **50-2 DELAY** or 1218 **50-3 DELAY**).

For motor protection, the 50-2 relay element must be set smaller than the smallest phase-to-phase fault current and larger than the largest motor starting current. Since the maximum occurring startup current is usually below $1.6 \times$ the rated startup current (even with unfavourable conditions), the following setting is adequate for the fault current element 50-2:

$$1.6 \times I_{\text{Startup}} < 50-2 \text{ Pickup} < I_{\text{fault,2pole,min}}$$

The potential increase in starting current caused by overvoltage conditions is already accounted for by the 1.6 factor. The 50-2 element can be tripped without delay (**50-2 DELAY** = 0.00 s), since saturation of the shunt reactance occurs in a motor, unlike in a transformer, for example.

The principle of the "reverse interlocking" utilizes the multi-element function of the time overcurrent protection: Element **50-2 PICKUP** is applied as a fast busbar protection with a shorter safety delay time **50-2 DELAY** (e.g. 100 ms). For faults at the outgoing feeders, element 50-2 is blocked. Both element 50-1 or 51 serve as backup protection. The pickup values of both elements (50-1 PICKUP or 51 PICKUP and 50-2 PICKUP) are set equal. Delay time **50-1 DELAY** or **51 TIME DIAL** is set in such manner that it overgrades the delay for the outgoing feeders.

The selected time is an additional delay time and does not include the operating time (measuring time, dropout time). The delay can be also be set to ∞ . In this case, the element will not trip after pickup. However, pickup, will be signaled. If the 50-2 element or the 50-3 element is not required at all, the pickup threshold 50-2 or 50-3 is set to ∞ . This setting prevents tripping and the generation of a pickup message.

High-set Current Elements 50N-2, 50N-3 (ground)

The pickup currents of the high-set elements **50N-2 PICKUP** or **50N-3 PICKUP** are set under address 1302 or 1317. The corresponding delay time **50N-2 DELAY** or **50N-3 DELAY** can be configured under address 1303 or 1318. The same considerations apply to these settings as they did for phase currents discussed earlier.

The selected time is an additional delay time and does not include the operating time (measuring time, dropout time). The delay can be also be set to ∞ . In this case, the element will not trip after pickup. However, pickup, will be signaled. If the 50N-2 element or 50N-3 element is not required at all, the pickup threshold 50N-2 or 50N-3 should be set to ∞ . This setting prevents tripping and the generation of a pickup message.

50-1 Element (phases)

For setting the 50-1 element, it is the maximum anticipated load current that must be considered above all. Pickup due to overload should never occur since in this mode the device operates as fault protection with correspondingly short tripping times and not as overload protection. For this reason, a setting equal to 20% of the expected peak load is recommended for line protection, and a setting equal to 40% is recommended for transformers and motors.

The settable time delay (address 1205 **50-1 DELAY**) results from the grading coordination chart defined for the system.

The selected time is an additional delay time and does not include the operating time (measuring time, dropout time). The delay can be also be set to ∞ . In this case, the element will not trip after pickup. However, pickup, will be signaled. If the 50-1 element is not required at all, then the pickup threshold 50-1 should be set to ∞ . This setting prevents tripping and the generation of a pickup message.

50N-1 Element (ground)

For setting the 50N-1 element, it is the minimum anticipated ground fault current that must be considered.

If the relay is used to protect transformers or motors with large inrush currents, the inrush restraint feature of 7SJ61 may be used for the 50N-1 relay element. It can be enabled or disabled for both the phase current and the ground current in address 2201 **INRUSH REST**. The characteristic values of the inrush restraint are listed in Subsection "Inrush Restraint".

The settable delay time (address 1305 **50N-1 DELAY**) results from the grading coordination chart defined for the system. For ground currents in a grounded system a separate coordination chart with shorter time delays is possible.

The selected time is an additional delay time and does not include the operating time (measuring time, dropout time). The delay can be also be set to ∞ . In this case, the element will not trip after pickup. However, pickup, will be signaled. If the 50N-1 element is not required at all, the pickup threshold 50N-1 PICKUP should be set to ∞ . This setting prevents tripping and the generation of a pickup message.

Pickup Stabilization (Definite Time)

The configurable dropout times 1215 **50 T DROP-OUT** or 1315 **50N T DROP-OUT** can be set to implement a uniform dropout behavior when using electromechanical relays. This is necessary for a time grading. The dropout time of the electromechanical relay must be known to this end. Subtract the dropout time of the device (see Technical Data) from this value and enter the result in the parameters.

51 Element (phases) with IEC or ANSI characteristics

Having set address 112 **Charac. Phase** = **TOC IEC** or **TOC ANSI** when configuring the protection functions (Section 2.1.1.2), the parameters for the inverse characteristics will also be available.

If address 112 **Charac. Phase** was set to **TOC IEC**, you can select the desired IEC characteristic (**Normal Inverse**, **Very Inverse**, **Extremely Inv.** or **Long Inverse**) at address 1211 **51 IEC CURVE**. If address 112 **Charac. Phase** was set to **TOC ANSI**, you can select the desired ANSI characteristic (**Very Inverse**, **Inverse**, **Short Inverse**, **Long Inverse**, **Moderately Inv.**, **Extremely Inv.** or **Definite Inv.**) at address 1212 **51 ANSI CURVE**.

If the inverse time trip characteristic is selected, it must be noted that a safety factor of about 1.1 has already been included between the pickup value and the setting value. This means that a pickup will only occur if a current of about 1.1 times the setting value is present. If **Disk Emulation** was selected at address 1210 **51 Drop-out**, reset will occur in accordance with the reset curve as described before.

The current value is set in address 1207 **51 PICKUP**. The setting is mainly determined by the maximum anticipated operating current. Pickup due to overload should never occur since in this mode the device operates as fault protection with correspondingly short tripping times and not as overload protection.

The corresponding time multiplier for an IEC characteristic is set at address 1208 **51 TIME DIAL** and in address 1209 **51 TIME DIAL** for an ANSI characteristic. It must be coordinated with the grading coordination chart of the system.

The time multiplier can also be set to ∞ . In this case, the element will not trip after pickup. However, pickup, will be signaled. If the 51 element is not required at all, address 112 **Charac. Phase** should be set to **Definite Time** during protective function configuration (see Section 2.1.1.2).

51N Element (ground) with IEC or ANSI Characteristics

Having set address 113 **Charac. Ground** = **TOC IEC** when configuring the protection functions (Section 2.1.1), the parameters for the inverse characteristics will also be available. Specify in address 1311 **51N IEC CURVE** the desired IEC characteristic (**Normal Inverse**, **Very Inverse**, **Extremely Inv.** or **Long Inverse**). If address 113 **Charac. Ground** was set to **TOC ANSI**, you can select the desired ANSI characteristic (**Very Inverse**, **Inverse**, **Short Inverse**, **Long Inverse**, **Moderately Inv.**, **Extremely Inv.** or **Definite Inv.**) at address 1312 **51N ANSI CURVE**.

If the inverse time trip characteristic is selected, it must be noted that a safety factor of about 1.1 has already been included between the pickup value and the setting value. This means that a pickup will only occur if a current of about 1.1 times the setting value is present. If **Disk Emulation** was selected at address 1310 **51 Drop-out**, reset will occur in accordance with the reset curve as described before.

The current value is set in address 1307 **51N PICKUP**. The setting is mainly determined by the minimum anticipated ground fault current.

The corresponding time multiplier for an IEC characteristic is set at address 1308 **51N TIME DIAL** and in address 1309 **51N TIME DIAL** for an ANSI characteristic. This has to be coordinated with the grading coordination chart of the network. For ground currents with grounded network, you can often set up a separate grading coordination chart with shorter delay times.

The time multiplier can also be set to ∞ . In this case, the element will not trip after pickup. However, pickup, will be signaled. If the 51N-TOC element is not required at all, address 113 **Charac. Ground** should be set to **Definite Time** during configuration of the protection functions (see Section 2.1.1).

User-defined Characteristics (phases and ground)

Having set address 112 **Charac. Phase** or 113 = **Charac. Ground** = **User Defined PU** or **User def. Reset** when configuring the protective functions (Section 2.1.1.2), the user-defined curves will also be available. A maximum of 20 value pairs (current and time) may be entered at address 1230 **51/51N** or 1330 **50N/51N** in this case. This option allows point-by-point entry of any desired curve. When setting address 112 = **User def. Reset** or 113 = **User def. Reset** additional value pairs (current and reset time) may be entered in address 1231 **MofPU Res T/Tp** or 1331 **MofPU Res T/TEp** to represent the dropout curve.

Since current values are rounded in a specific pattern before they are processed in the device (see Table 2-3), we recommend to use exactly the same preferred current values you can find in this table.

The current and time value pairs are entered as multiples of addresses 1207 **51 PICKUP** and 1208 **51 TIME DIAL** for the phase currents and 1307 and 1308 for the ground system. Therefore, it is recommended that these addresses are initially set to 1.00 for simplicity. Once the curve is entered, the values at addresses 1207 or 1307 or/and 1208 or 1308 can be modified later to allow moving the curve in a different direction.

The default setting of current values is ∞. They are, therefore, disabled and no pickup or tripping of these protection functions will occur.

The following must be observed:

- The value pairs should be entered in increasing sequence. If desired, fewer than 20 pairs can be entered. In most cases, about 10 pairs is sufficient to define the characteristic accurately. A value pair which is not used has to be made invalid by entering "∞" for the threshold! The user must ensure that the value pairs produce a clear and constant characteristic .

The current values entered should be those from the following table, along with the matching times. Deviating values MofPU (multiples of PU-values) are rounded. This, however, will not be indicated.

Currents smaller than the current value of the smallest curve point will not lead to an extension of the tripping time. The pickup curve (see Figure 2-14, right side) runs parallel to the current axis, up to the smallest current value point.

Currents larger than the largest current value entered will not lead to a reduction of the tripping time. The pickup curve (see Figure 2-14, right side) runs parallel to the current axis, beginning with the greatest current value point.

Table 2-3 Preferential values of standardized currents for user-defined tripping curves

MofPU = 1 to 1.94		MofPU = 2 to 4.75		MofPU = 5 to 7.75		MofPU = 8 to 20	
1.00	1.50	2.00	3.50	5.00	6.50	8.00	15.00
1.06	1.56	2.25	3.75	5.25	6.75	9.00	16.00
1.13	1.63	2.50	4.00	5.50	7.00	10.00	17.00
1.19	1.69	2.75	4.25	5.75	7.25	11.00	18.00
1.25	1.75	3.00	4.50	6.00	7.50	12.00	19.00
1.31	1.81	3.25	4.75	6.25	7.75	13.00	20.00
1.38	1.88					14.00	
1.44	1.94						

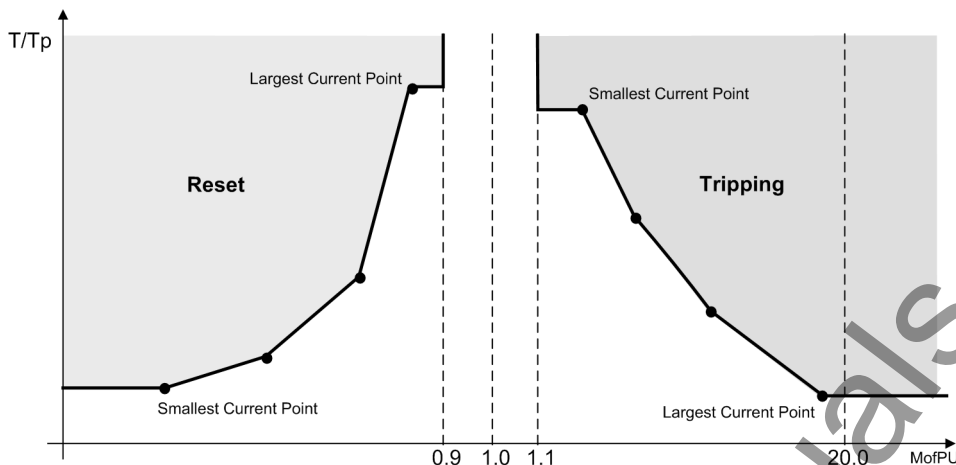

Figure 2-14 Using a user-defined curve

The value pairs are entered at address 1231 **MofPU Res T/Tp** or 1331 **MofPU Res T/TEp** to recreate the reset curve. The following must be observed:

- The current values entered should be those from the following Table 2-4, along with the matching times. Deviating values of MofPU are rounded. This, however, will not be indicated.

Currents larger than the largest current value entered will not lead to an extension of the dropout time. The dropout curve (see Figure 2-14, left side) runs parallel to the current axis, up to the largest curve value point.

Currents which are smaller than the smallest current value entered will not lead to a reduction of the dropout time. The dropout curve (see Figure 2-14, left side) runs parallel to the current axis, beginning with the smallest curve value point.

Table 2-4 Preferential values of standardized currents for user-defined reset curves

MofPU = 1 to 0.86		MofPU = 0.84 to 0.67		MofPU = 0.66 to 0.38		MofPU = 0.34 to 0.00	
1.00	0.93	0.84	0.75	0.66	0.53	0.34	0.16
0.99	0.92	0.83	0.73	0.64	0.50	0.31	0.13
0.98	0.91	0.81	0.72	0.63	0.47	0.28	0.09
0.97	0.90	0.80	0.70	0.61	0.44	0.25	0.06
0.96	0.89	0.78	0.69	0.59	0.41	0.22	0.03
0.95	0.88	0.77	0.67	0.56	0.38	0.19	0.00
0.94	0.86						

When using DIGSI to make settings, a dialog box opens where you can enter up to 20 value pairs (measured quantity and trip time) (see Figure 2-15).

In order to represent the characteristic graphically, the user should click on "characteristic". The previously entered characteristic will appear as shown in Figure 2-15.

The characteristic curve shown in the graph can be modified later on. Placing the mouse cursor over a point on the characteristic, the cursor changes to the shape of a hand. Press and hold the left mouse button and drag the data item to the desired position. Releasing the mouse button will automatically update the value in the value table.

The respective upper limits of the ranges of value are indicated by dotted lines in the right-hand and upper area of the system of coordinates. If the position of a data point lies outside these limits, the associated value is set to infinity.

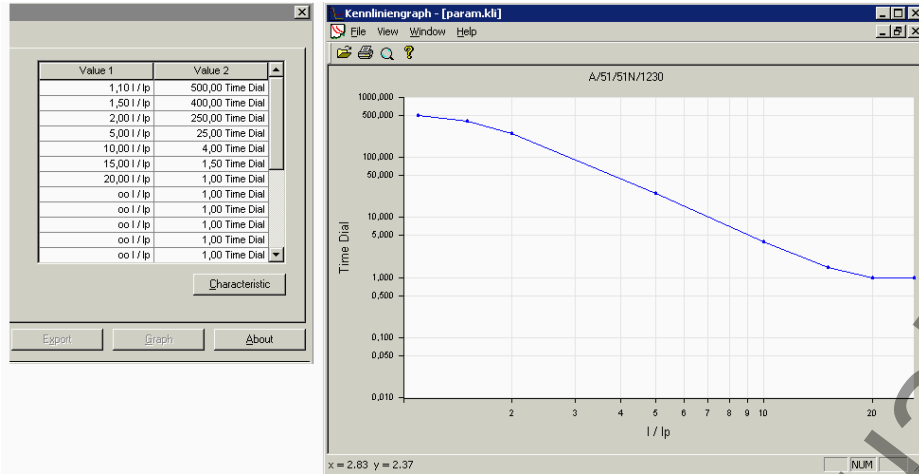

Figure 2-15 Entry and visualization of a user-defined tripping characteristic in DigiS — example

Inrush Restraint

When applying the protection device to transformers where high inrush currents are to be expected, the 7SJ61 can make use of an inrush restraint function for the overcurrent elements 50-1, 51, 50N-1 and 51N as well as the non-directional overcurrent elements.

Inrush restraint is only effective and accessible if address 122 **InrushRestraint** was set to **Enabled**. If this function is not required, then **Disabled** is set. In address 2201, **INRUSH REST.** the function is switched **ON** or **OFF** jointly for the overcurrent elements **.50-1 PICKUP, 51 PICKUP, 50N-1 PICKUP** and **51N PICKUP**

The inrush restraint is based on the evaluation of the 2nd harmonic present in the inrush current. Upon delivery from the factory, a ratio I_{2f}/I_f of 15 % is set. Under normal circumstances, this setting will not need to be changed. The setting value is identical for all phases and ground. However, the component required for restraint may be adjusted to system conditions in address 2202 **2nd HARMONIC**. To provide more restraint in exceptional cases, where energizing conditions are particularly unfavorable, a smaller value can be set in the aforementioned address, e.g. 12 %. Irrespective of parameter 2202 **2nd HARMONIC**, rush blocking will only occur if the absolute value of the 2nd harmonic is at least $0.025 \cdot I_{Nom,sec}$.

The effective duration of the cross-blocking 2203 **CROSS BLK TIMER** can be set to a value between 0 s (harmonic restraint active for each phase individually) and a maximum of 180 s (harmonic restraint of a phase blocks also the other phases for the specified duration).

If the current exceeds the value set in address 2205 **I Max**, no further restraint will take place for the 2nd harmonic.

Manual Close Mode (phases,ground)

When a circuit breaker is closed onto a faulted line, a high-speed trip by the circuit breaker is usually desired. For overcurrent or high-set element the delay may be bypassed via a Manual Close pulse, thus resulting in instantaneous tripping. This pulse is prolonged by at least 300 ms. To enable the device to react properly on occurrence of a fault in the phase elements, address 1213 **MANUAL CLOSE** has to be set accordingly. Correspondingly, address 1313 **MANUAL CLOSE** is considered for the ground path address. Thus, the user determines for both elements, the phase and the ground element, what pickup value is active with what delay when the circuit breaker is closed manually.

External Control Command

If the manual close signal is not sent from 7SJ61 device, i.e. neither via the built-in operator interface nor via a serial interface, but directly from a control acknowledgment switch, this signal must be passed to a 7SJ61 binary input, and configured accordingly („>Manual Close“), so that the element selected for **MANUAL CLOSE** can become effective. The alternative **Inactive** means that all elements operate as per configuration even with manual close and do not get special treatment.

Internal Control Function

If the manual close signal is sent via the internal control function of the device, an internal connection of information has to be established via CFC (interlocking task level) using the CMD_Information block (see Figure 2-16).

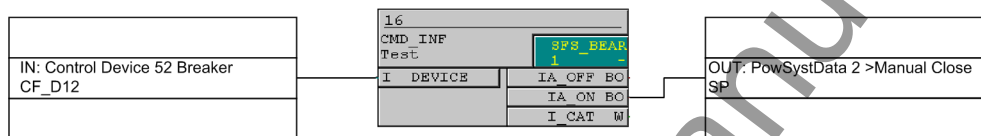

Figure 2-16 Example for the generation of a manual close signal using the internal control function



Note

For an interaction between the automatic reclosing function (79 AR) and the control function, an extended CFC logic is necessary. See margin heading „Close command: Directly or via Control“ in the Setting Notes of the automatic reclosing function (Section 2.11.6).

Interaction with the Automatic Reclosing Function (phases)

When reclosing occurs, it is desirable to have high-speed protection against faults with 50-2 or 50-3. If the fault still exists after the first reclosing, the 50-1 or 51 elements will be initiated with graded tripping times, that is, element 50-2 or 50-3 will be blocked. At address 1214 **50-2 active** or 1216 **50-3 active** it can be specified whether the 50-2 or the 50-3 element should be influenced by the status of an internal or external automatic reclosing system. The setting **with 79 active** means that the 50-2 or 50-3 elements will only be released if automatic reclosing is not blocked. If this is not desired, choose the setting **Always** so that the 50-2 or 50-3 elements will always be active.

The integrated automatic reclosing function of 7SJ61 also provides the option to individually determine for each overcurrent element whether tripping or blocking is to be carried out instantaneously, unaffected by the AR with the set time delay (see Section 2.11).

Interaction with the Automatic Reclosing Function (ground)

When reclosing occurs, it is desirable to have high-speed protection against faults with 50N-2 or 50N-3. If the fault still exists after the first reclosing, the 50N-1 or 51N elements or will be initiated with graded tripping times, that is, element 50N-2 or 50N-3 will be blocked. At address 1314 **50N-2 active** or 1316 **50N-3 active** it can be specified whether the 50N-2 or the 50N-3 element should be influenced by the status of an internal or external automatic reclosing system. Address **with 79 active** determines that the 50N-2 or 50N-3 elements will only operate if automatic reclosing is not blocked. If this is not desired, select the setting **Always** so that the 50N-2 or 50N-3 elements will always operate, as configured.

The integrated automatic reclosing function of 7SJ61 also provides the option to individually determine for each overcurrent element whether tripping or blocking is to be carried out instantaneously, unaffected by the AR with the set time delay (see Section 2.11).

2.2.11 Settings

Addresses which have an appended "A" can only be changed with DIGSI, under "Display Additional Settings".

The table indicates region-specific default settings. Column C (configuration) indicates the corresponding secondary nominal current of the current transformer.

Addr.	Parameter	C	Setting Options	Default Setting	Comments
1201	FCT 50/51		ON OFF	ON	50, 51 Phase Time Over-current
1202	50-2 PICKUP	1A	0.10 .. 35.00 A; ∞	2.00 A	50-2 Pickup
		5A	0.50 .. 175.00 A; ∞	10.00 A	
1203	50-2 DELAY		0.00 .. 60.00 sec; ∞	0.00 sec	50-2 Time Delay
1204	50-1 PICKUP	1A	0.10 .. 35.00 A; ∞	1.00 A	50-1 Pickup
		5A	0.50 .. 175.00 A; ∞	5.00 A	
1205	50-1 DELAY		0.00 .. 60.00 sec; ∞	0.50 sec	50-1 Time Delay
1207	51 PICKUP	1A	0.10 .. 4.00 A	1.00 A	51 Pickup
		5A	0.50 .. 20.00 A	5.00 A	
1208	51 TIME DIAL		0.05 .. 3.20 sec; ∞	0.50 sec	51 Time Dial
1209	51 TIME DIAL		0.50 .. 15.00 ; ∞	5.00	51 Time Dial
1210	51 Drop-out		Instantaneous Disk Emulation	Disk Emulation	Drop-out characteristic
1211	51 IEC CURVE		Normal Inverse Very Inverse Extremely Inv. Long Inverse	Normal Inverse	IEC Curve
1212	51 ANSI CURVE		Very Inverse Inverse Short Inverse Long Inverse Moderately Inv. Extremely Inv. Definite Inv.	Very Inverse	ANSI Curve
1213A	MANUAL CLOSE		50-3 instant. 50-2 instant. 50 -1 instant. 51 instant. Inactive	50-2 instant.	Manual Close Mode
1214A	50-2 active		Always with 79 active	Always	50-2 active
1215A	50 T DROP-OUT		0.00 .. 60.00 sec	0.00 sec	50 Drop-Out Time Delay
1216A	50-3 active		Always with 79 active	Always	50-3 active
1217	50-3 PICKUP	1A	1.00 .. 35.00 A; ∞	∞ A	50-3 Pickup
		5A	5.00 .. 175.00 A; ∞	∞ A	
1218	50-3 DELAY		0.00 .. 60.00 sec; ∞	0.00 sec	50-3 Time Delay

Addr.	Parameter	C	Setting Options	Default Setting	Comments
1219A	50-3 measurem.		Fundamental True RMS Instantaneous	Fundamental	50-3 measurement of
1220A	50-2 measurem.		Fundamental True RMS	Fundamental	50-2 measurement of
1221A	50-1 measurem.		Fundamental True RMS	Fundamental	50-1 measurement of
1222A	51 measurem.		Fundamental True RMS	Fundamental	51 measurement of
1230	51/51N		1.00 .. 20.00 I/lp; ∞ 0.01 .. 999.00 TD		51/51N
1231	MofPU Res T/Tp		0.05 .. 0.95 I/lp; ∞ 0.01 .. 999.00 TD		Multiple of Pickup <-> T/Tp
1301	FCT 50N/51N		ON OFF	ON	50N, 51N Ground Time Overcurrent
1302	50N-2 PICKUP	1A	0.05 .. 35.00 A; ∞	0.50 A	50N-2 Pickup
		5A	0.25 .. 175.00 A; ∞	2.50 A	
1303	50N-2 DELAY		0.00 .. 60.00 sec; ∞	0.10 sec	50N-2 Time Delay
1304	50N-1 PICKUP	1A	0.05 .. 35.00 A; ∞	0.20 A	50N-1 Pickup
		5A	0.25 .. 175.00 A; ∞	1.00 A	
1305	50N-1 DELAY		0.00 .. 60.00 sec; ∞	0.50 sec	50N-1 Time Delay
1307	51N PICKUP	1A	0.05 .. 4.00 A	0.20 A	51N Pickup
		5A	0.25 .. 20.00 A	1.00 A	
1308	51N TIME DIAL		0.05 .. 3.20 sec; ∞	0.20 sec	51N Time Dial
1309	51N TIME DIAL		0.50 .. 15.00 ; ∞	5.00	51N Time Dial
1310	51N Drop-out		Instantaneous Disk Emulation	Disk Emulation	Drop-Out Characteristic
1311	51N IEC CURVE		Normal Inverse Very Inverse Extremely Inv. Long Inverse	Normal Inverse	IEC Curve
1312	51N ANSI CURVE		Very Inverse Inverse Short Inverse Long Inverse Moderately Inv. Extremely Inv. Definite Inv.	Very Inverse	ANSI Curve
1313A	MANUAL CLOSE		50N-3 instant. 50N-2 instant. 50N-1 instant. 51N instant. Inactive	50N-2 instant.	Manual Close Mode
1314A	50N-2 active		Always With 79 Active	Always	50N-2 active
1315A	50N T DROP-OUT		0.00 .. 60.00 sec	0.00 sec	50N Drop-Out Time Delay

Addr.	Parameter	C	Setting Options	Default Setting	Comments
1316A	50N-3 active		Always with 79 active	Always	50N-3 active
1317	50N-3 PICKUP		0.25 .. 35.00 A; ∞	∞ A	50N-3 Pickup
1318	50N-3 DELAY		0.00 .. 60.00 sec; ∞	0.00 sec	50N-3 Time Delay
1319A	50N-3 measur.		Fundamental True RMS Instantaneous	Fundamental	50N-3 measurement of
1320A	50N-2 measur.		Fundamental True RMS	Fundamental	50N-2 measurement of
1321A	50N-1 measur.		Fundamental True RMS	Fundamental	50N-1 measurement of
1322A	51N measur.		Fundamental True RMS	Fundamental	51N measurement of
1330	50N/51N		1.00 .. 20.00 I/Ip; ∞ 0.01 .. 999.00 TD		50N/51N
1331	MofPU Res T/TEp		0.05 .. 0.95 I/Ip; ∞ 0.01 .. 999.00 TD		Multiple of Pickup <-> T/TEp
2201	INRUSH REST.		OFF ON	OFF	Inrush Restraint
2202	2nd HARMONIC		10 .. 45 %	15 %	2nd. harmonic in % of fun- damental
2203	CROSS BLOCK		NO YES	NO	Cross Block
2204	CROSS BLK TIMER		0.00 .. 180.00 sec	0.00 sec	Cross Block Time
2205	I Max	1A	0.30 .. 25.00 A	7.50 A	Maximum Current for Inrush Restraint
		5A	1.50 .. 125.00 A	37.50 A	

2.2.12 Information List

No.	Information	Type of Information	Comments
1704	>BLK 50/51	SP	>BLOCK 50/51
1714	>BLK 50N/51N	SP	>BLOCK 50N/51N
1718	>BLOCK 50-3	SP	>BLOCK 50-3
1719	>BLOCK 50N-3	SP	>BLOCK 50N-3
1721	>BLOCK 50-2	SP	>BLOCK 50-2
1722	>BLOCK 50-1	SP	>BLOCK 50-1
1723	>BLOCK 51	SP	>BLOCK 51
1724	>BLOCK 50N-2	SP	>BLOCK 50N-2
1725	>BLOCK 50N-1	SP	>BLOCK 50N-1
1726	>BLOCK 51N	SP	>BLOCK 51N
1751	50/51 PH OFF	OUT	50/51 O/C switched OFF
1752	50/51 PH BLK	OUT	50/51 O/C is BLOCKED
1753	50/51 PH ACT	OUT	50/51 O/C is ACTIVE
1756	50N/51N OFF	OUT	50N/51N is OFF
1757	50N/51N BLK	OUT	50N/51N is BLOCKED
1758	50N/51N ACT	OUT	50N/51N is ACTIVE
1761	50(N)/51(N) PU	OUT	50(N)/51(N) O/C PICKUP
1762	50/51 Ph A PU	OUT	50/51 Phase A picked up
1763	50/51 Ph B PU	OUT	50/51 Phase B picked up
1764	50/51 Ph C PU	OUT	50/51 Phase C picked up
1765	50N/51N Picked up	OUT	50N/51N picked up
1767	50-3 picked up	OUT	50-3 picked up
1768	50N-3 picked up	OUT	50N-3 picked up
1769	50-3 TRIP	OUT	50-3 TRIP
1770	50N-3 TRIP	OUT	50N-3 TRIP
1787	50-3 TimeOut	OUT	50-3 TimeOut
1788	50N-3 TimeOut	OUT	50N-3 TimeOut
1791	50(N)/51(N)TRIP	OUT	50(N)/51(N) TRIP
1800	50-2 picked up	OUT	50-2 picked up
1804	50-2 TimeOut	OUT	50-2 Time Out
1805	50-2 TRIP	OUT	50-2 TRIP
1810	50-1 picked up	OUT	50-1 picked up
1814	50-1 TimeOut	OUT	50-1 Time Out
1815	50-1 TRIP	OUT	50-1 TRIP
1820	51 picked up	OUT	51 picked up
1824	51 Time Out	OUT	51 Time Out
1825	51 TRIP	OUT	51 TRIP
1831	50N-2 picked up	OUT	50N-2 picked up
1832	50N-2 TimeOut	OUT	50N-2 Time Out
1833	50N-2 TRIP	OUT	50N-2 TRIP
1834	50N-1 picked up	OUT	50N-1 picked up
1835	50N-1 TimeOut	OUT	50N-1 Time Out
1836	50N-1 TRIP	OUT	50N-1 TRIP
1837	51N picked up	OUT	51N picked up

No.	Information	Type of Information	Comments
1838	51N TimeOut	OUT	51N Time Out
1839	51N TRIP	OUT	51N TRIP
1840	PhA InrushDet	OUT	Phase A inrush detection
1841	PhB InrushDet	OUT	Phase B inrush detection
1842	PhC InrushDet	OUT	Phase C inrush detection
1843	INRUSH X-BLK	OUT	Cross blk: PhX blocked PhY
1851	50-1 BLOCKED	OUT	50-1 BLOCKED
1852	50-2 BLOCKED	OUT	50-2 BLOCKED
1853	50N-1 BLOCKED	OUT	50N-1 BLOCKED
1854	50N-2 BLOCKED	OUT	50N-2 BLOCKED
1855	51 BLOCKED	OUT	51 BLOCKED
1856	51N BLOCKED	OUT	51N BLOCKED
1866	51 Disk Pickup	OUT	51 Disk emulation Pickup
1867	51N Disk Pickup	OUT	51N Disk emulation picked up
7551	50-1 InRushPU	OUT	50-1 InRush picked up
7552	50N-1 InRushPU	OUT	50N-1 InRush picked up
7553	51 InRushPU	OUT	51 InRush picked up
7554	51N InRushPU	OUT	51N InRush picked up
7556	InRush OFF	OUT	InRush OFF
7557	InRush BLK	OUT	InRush BLOCKED
7558	InRush Gnd Det	OUT	InRush Ground detected
7563	>BLOCK InRush	SP	>BLOCK InRush
7564	Gnd InRush PU	OUT	Ground InRush picked up
7565	Ia InRush PU	OUT	Phase A InRush picked up
7566	Ib InRush PU	OUT	Phase B InRush picked up
7567	Ic InRush PU	OUT	Phase C InRush picked up
10034	50-3 BLOCKED	OUT	50-3 BLOCKED
10035	50N-3 BLOCKED	OUT	50N-3 BLOCKED

2.3 Dynamic Cold Load Pickup

With the cold load pickup function, pickup and delay settings of time overcurrent protection can be changed over dynamically.

Applications

- It may be necessary to dynamically increase the pickup values if, during starting and for a short time thereafter, certain elements of the system have an increased power consumption after a long period of zero voltage (e.g. air-conditioning systems, heating installations, motors). Thus a raise of pickup thresholds can be avoided by taking into consideration such starting conditions.
- As a further option the pickup thresholds may be modified by an automatic reclosure function in accordance with its ready or not ready state.

Prerequisites

Note:

Dynamic cold load pickup is not to be confused with the changeover option of the 4 setting groups (A to D). It is an additional feature.

It is possible to change pickup thresholds and delay times.

2.3.1 Description

Effect

There are two methods by which the device can determine if the protected equipment is de-energized:

- Via binary inputs, the device is informed of the position of the circuit breaker (address 1702 **Start Condition = Breaker Contact**).
- As a criterion a set current threshold is undershot (address 1702 **Start Condition = No Current**).

If the device determines that the protected equipment is de-energized via one of the above methods, a time, **CB Open Time**, is started and after its expiration the increased thresholds take effect.

In addition, switching between parameters can be triggered by two further events:

- by signal "79M Auto Reclosing ready" of the internal automatic reclosure function (address 1702 **Start Condition = 79 ready**). Thus the protection thresholds and the tripping times can be changed if automatic reclosure is ready for reclosing (see also Section 2.11).
- Irrespective of the setting of parameter 1702 **Start Condition**, the release of cold load pickup may always be selected via the binary input „>ACTIVATE CLP“.

Figure 2-18 shows the logic diagram for dynamic cold load pickup function.

If it is detected via the auxiliary contact or the current criterion that the system is de-energized, i.e. the circuit breaker is open, the **CB Open Time** is started. As soon as it has elapsed, the greater thresholds are enabled. When the protected equipment is re-energized (the device receives this information via the binary inputs or when threshold **BkrClosed I MIN** is exceeded), a second time delay referred to as the **Active Time** is initiated. Once it elapses, the pickup values of the relay elements return to their normal settings. This time may be reduced when current values fall below all normal pickup values for a set **Stop Time** after startup, i.e. after the circuit breaker has been closed. The starting condition of the fast reset time is made up of an OR-combination of the configured dropout conditions of all non-directional overcurrent elements. When **Stop Time** is set to ∞ or when binary input „>BLK CLP stpTim“ is active, no comparison is made with the "normal" thresholds. The function is inactive and the fast reset time, if applied, is reset.

If overcurrent elements are picked up while time **Active Time** is running, the fault generally prevails until pickup drops out, using the dynamic settings. Only then the parameters are set back to "normal".

If the dynamic setting values were activated via the binary input „>ACTIVATE CLP“ or the signal "79M Auto Reclosing ready" and this cause drops out, the "normal" settings are restored immediately, even if a pickup is the result.

If the binary input „>BLOCK CLP“ is enabled, all triggered timers are reset and, as a consequence, all "normal" settings are immediately restored. If blocking occurs during an on-going fault with dynamic cold load pickup functions enabled, the timers of all non-directional overcurrent relay elements are stopped and may then be restarted based on their normal duration.

During power up of the protective relay with an open circuit breaker, the time delay **CB Open Time** is started, and is processed using the "normal" settings. Therefore, when the circuit breaker is closed, the "normal" settings are effective.

Figure 2-17 illustrates the timing sequence. Figure 2-18 shows the logic diagram of the dynamic cold load pickup feature.

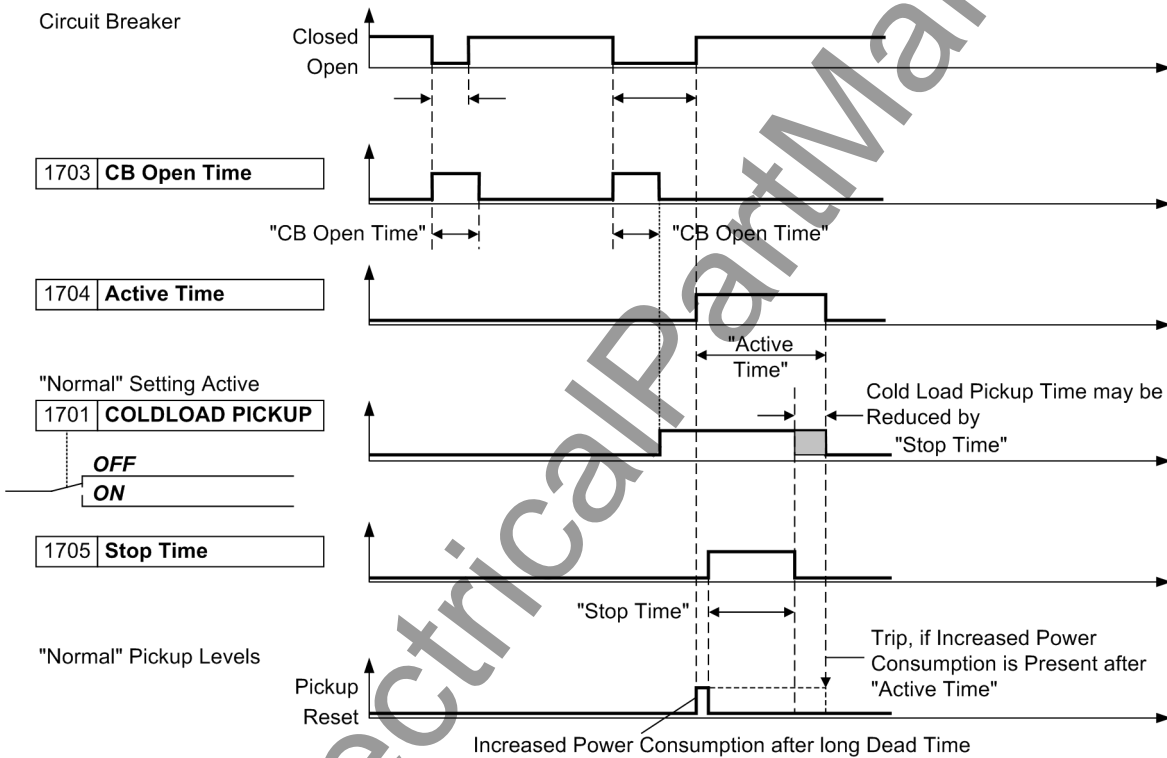

Figure 2-17 Timing charts of the dynamic cold load pickup function

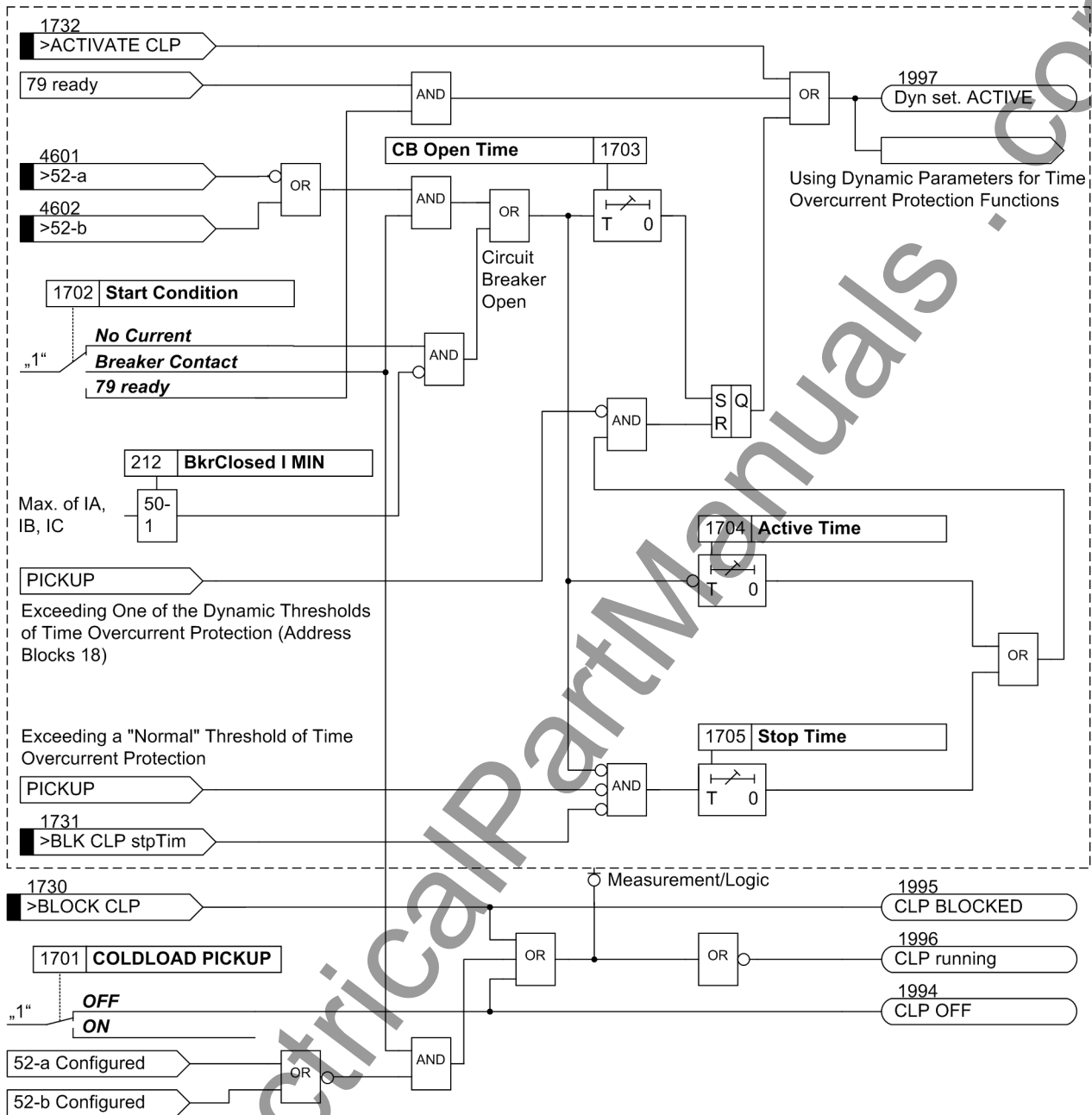

Figure 2-18 Logic diagram of the dynamic cold load pickup function (50c, 50Nc, 51c, 51Nc, 67c, 67Nc)

2.3.2 Setting Notes

General

The dynamic cold load pickup function can only be enabled if address 117 **Coldload Pickup** was set to **Enabled** during configuration of the protective functions. If not required, this function should be set to **Disabled**. The function can be turned **ON** or **OFF** under address 1701 **Coldload Pickup**.

Depending on the conditions that should initiate the cold load pickup function address 1702 **Start Condition** is set to either **No Current**, **Breaker Contact** or to **79 ready**. Naturally, the option **Breaker Contact** can only be selected if the device receives information regarding the switching state of the circuit breaker via at least one binary input. The option **79 ready** modifies dynamically the pickup thresholds of the overcurrent protection when the automatic reclosing feature is ready. To initiate the cold load pickup the automatic reclosing function provides the internal signal „79M Auto Reclosing ready“. It is always active when auto-reclosure is available, activated, unblocked, and ready for a further cycle (see also Subsection 2.11).

Time Delays

There are no specific procedures on how to set the time delays at addresses 1703 **CB Open Time**, 1704 **Active Time** and 1705 **Stop Time**. These time delays must be based on the specific loading characteristics of the equipment being protected, and should be set to allow for brief overloads associated with dynamic cold load conditions.

50/51 Elements (phases)

The dynamic pickup values and tripping times associated with the time overcurrent protection functions are set at address block 18 for the phase currents:

The dynamic pickup and delay settings for the high-set elements are set at addresses 1801 **50c-2 PICKUP** or 1808 **50c-3 PICKUP** and 1802 **50c-2 DELAY** or 1809 **50c-3 DELAY** respectively; the dynamic pickup and delay settings for the 67N-1 element are set at addresses 1803 **50c-1 PICKUP** and 1804 **50c-1 DELAY** respectively; and the pickup, time multiplier (for IEC curves or user-defined curves), and time dial (for ANSI curves) settings for the 67N-TOC element are set at addresses 1805 **51c PICKUP**, 1806 **51c TIME DIAL** and 1807 **51c TIME DIAL** respectively.

50N/51N Elements (ground)

The dynamic pickup values and time delays associated with non-directional time overcurrent ground protection are set at address block 19:

The dynamic pickup and delay settings for the high-set elements are set at addresses 1901 **50Nc-2 PICKUP** or 1908 **50Nc-3 PICKUP** and 1902 **50Nc-2 DELAY** or 1909 **50Nc-3 DELAY** respectively; the dynamic pickup and delay settings for the 67N-1 element are set at addresses 1903 **50Nc-1 PICKUP** and 1904 **50Nc-1 DELAY** respectively; and the pickup, time multiplier (for IEC curves or user-defined curves), and time dial (for ANSI curves) settings for the 67N-TOC element are set at addresses 1905 **51Nc PICKUP**, 1906 **51Nc T-DIAL** and 1907 **51Nc T-DIAL** respectively.

2.3.3 Settings

The table indicates region-specific default settings. Column C (configuration) indicates the corresponding secondary nominal current of the current transformer.

Addr.	Parameter	C	Setting Options	Default Setting	Comments
1701	COLDLOAD PICKUP		OFF ON	OFF	Cold-Load-Pickup Function
1702	Start Condition		No Current Breaker Contact 79 ready	No Current	Start Condition
1703	CB Open Time		0 .. 21600 sec	3600 sec	Circuit Breaker OPEN Time
1704	Active Time		1 .. 21600 sec	3600 sec	Active Time
1705	Stop Time		1 .. 600 sec; ∞	600 sec	Stop Time
1801	50c-2 PICKUP	1A	0.10 .. 35.00 A; ∞	10.00 A	50c-2 Pickup
		5A	0.50 .. 175.00 A; ∞	50.00 A	
1802	50c-2 DELAY		0.00 .. 60.00 sec; ∞	0.00 sec	50c-2 Time Delay
1803	50c-1 PICKUP	1A	0.10 .. 35.00 A; ∞	2.00 A	50c-1 Pickup
		5A	0.50 .. 175.00 A; ∞	10.00 A	
1804	50c-1 DELAY		0.00 .. 60.00 sec; ∞	0.30 sec	50c-1 Time Delay
1805	51c PICKUP	1A	0.10 .. 4.00 A	1.50 A	51c Pickup
		5A	0.50 .. 20.00 A	7.50 A	
1806	51c TIME DIAL		0.05 .. 3.20 sec; ∞	0.50 sec	51c Time dial
1807	51c TIME DIAL		0.50 .. 15.00 ; ∞	5.00	51c Time dial
1808	50c-3 PICKUP	1A	1.00 .. 35.00 A; ∞	∞ A	50c-3 Pickup
		5A	5.00 .. 175.00 A; ∞	∞ A	
1809	50c-3 DELAY		0.00 .. 60.00 sec; ∞	0.00 sec	50c-3 Time Delay
1901	50Nc-2 PICKUP	1A	0.05 .. 35.00 A; ∞	7.00 A	50Nc-2 Pickup
		5A	0.25 .. 175.00 A; ∞	35.00 A	
1902	50Nc-2 DELAY		0.00 .. 60.00 sec; ∞	0.00 sec	50Nc-2 Time Delay
1903	50Nc-1 PICKUP	1A	0.05 .. 35.00 A; ∞	1.50 A	50Nc-1 Pickup
		5A	0.25 .. 175.00 A; ∞	7.50 A	
1904	50Nc-1 DELAY		0.00 .. 60.00 sec; ∞	0.30 sec	50Nc-1 Time Delay
1905	51Nc PICKUP	1A	0.05 .. 4.00 A	1.00 A	51Nc Pickup
		5A	0.25 .. 20.00 A	5.00 A	
1906	51Nc T-DIAL		0.05 .. 3.20 sec; ∞	0.50 sec	51Nc Time Dial
1907	51Nc T-DIAL		0.50 .. 15.00 ; ∞	5.00	51Nc Time Dial
1908	50Nc-3 PICKUP		0.25 .. 35.00 A; ∞	∞ A	50Nc-3 Pickup
1909	50Nc-3 DELAY		0.00 .. 60.00 sec; ∞	0.00 sec	50Nc-3 Time Delay

2.3.4 Information List

No.	Information	Type of Information	Comments
1730	>BLOCK CLP	SP	>BLOCK Cold-Load-Pickup
1731	>BLK CLP stpTim	SP	>BLOCK Cold-Load-Pickup stop timer
1732	>ACTIVATE CLP	SP	>ACTIVATE Cold-Load-Pickup
1994	CLP OFF	OUT	Cold-Load-Pickup switched OFF
1995	CLP BLOCKED	OUT	Cold-Load-Pickup is BLOCKED
1996	CLP running	OUT	Cold-Load-Pickup is RUNNING
1997	Dyn set. ACTIVE	OUT	Dynamic settings are ACTIVE

2.4 Single-Phase Overcurrent Protection

The single-phase overcurrent protection evaluates the current that is measured by the sensitive I_{NS} - or the normal I_N input. Which input is used depends on the device version according to the order number.

Applications

- Plain ground fault protection at a power transformer;
- Sensitive tank leakage protection.

2.4.1 Functional Description

The single-phase definite time overcurrent ground protection is illustrated by the tripping characteristic as shown in Figure 2-19. The current to be measured is filtered by numerical algorithms. Because of the high sensitivity a particularly narrow band filter is used. The current pickup thresholds and tripping times can be set. The detected current is compared to the pickup value 50 1Ph-1 PICKUP or 50 1Ph-2 PICKUP and reported if this is violated. After expiry of the respective delay time 50 1Ph-1 DELAY or 50 1Ph-2 DELAY, the trip command is issued. The two elements together form a two-stage protection. The dropout value is approximately 95% of the pickup value for currents greater than $I > 0.3 \cdot I_{Nom}$.

The current filter is bypassed if currents are extremely high in order to achieve a short tripping time. This occurs automatically as soon as the instantaneous value of the current exceeds the set value of the **50 1Ph-2 PICKUP** element by at least factor $2 \cdot \sqrt{2}$.

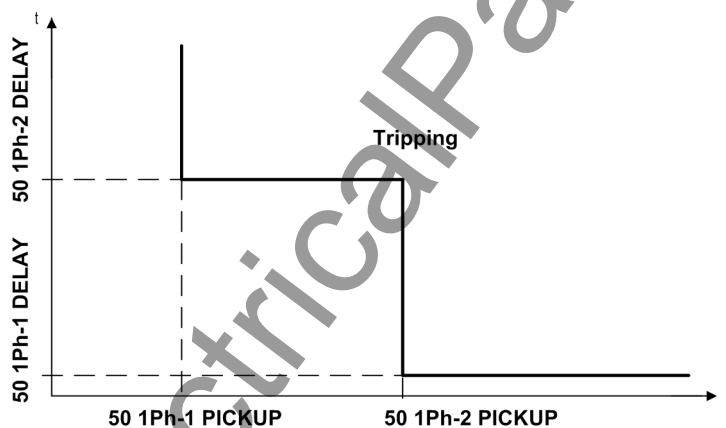

Figure 2-19 Two-stage characteristic of the single-phase time-overcurrent protection

The following figure shows the logic diagram of the single-phase overcurrent protection function.

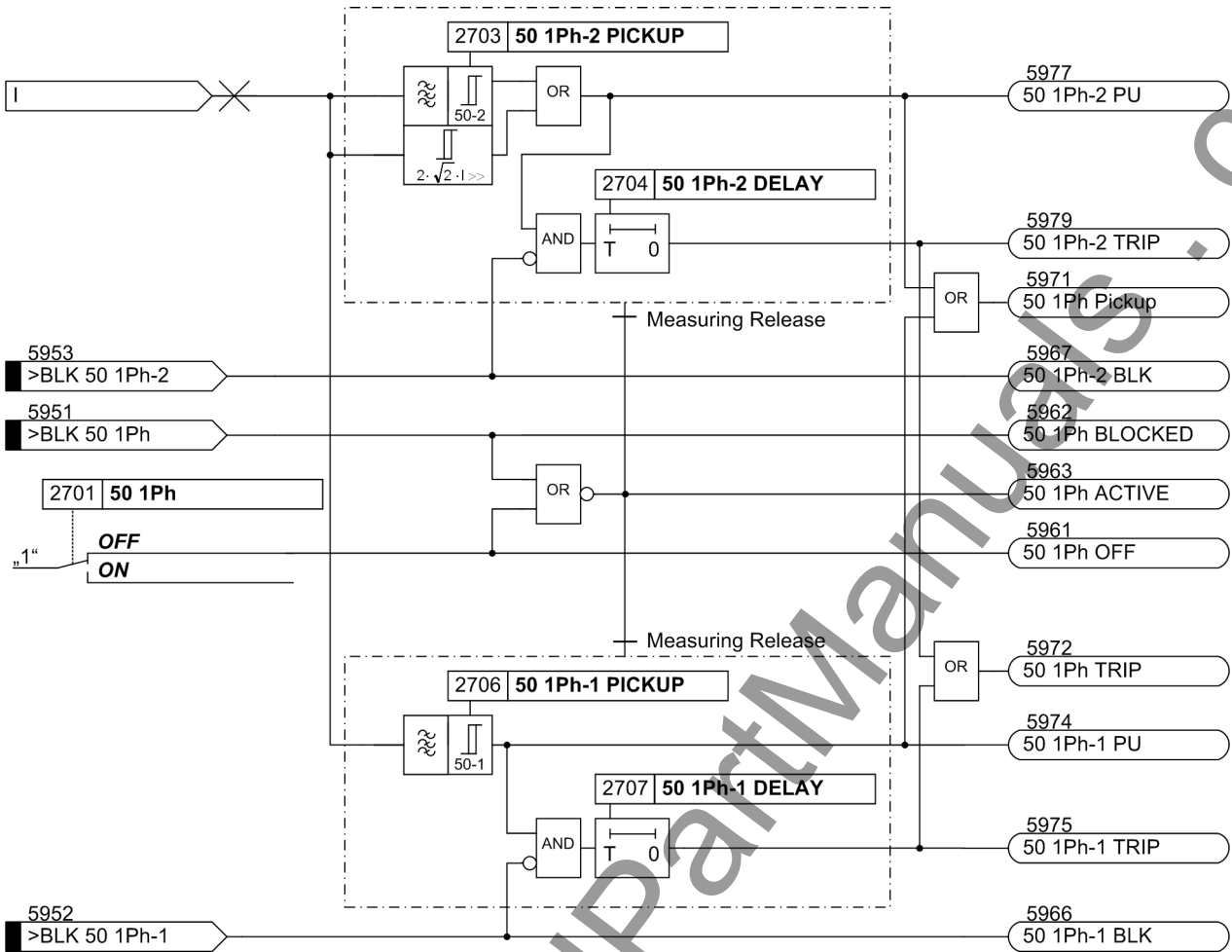

Figure 2-20 Logic diagram of the single-phase time overcurrent protection

2.4.2 High-impedance Ground Fault Unit Protection

Application Examples

In the high-impedance procedure, all CT's operate at the limits of the protected zone parallel on a common, relatively high-resistive resistor R whose voltage is measured.

The CTs must be of the same design and feature at least a separate core for high-impedance protection. In particular, they must have the same transformer ratios and approximately identical knee-point voltage.

With 7SJ61, the high-impedance principle is particularly well suited for detecting ground faults in grounded networks at transformers, generators, motors and shunt reactors.

Figure 2-21 shows an application example for a grounded transformer winding or a grounded motor/generator. The right-hand example depicts an ungrounded transformer winding or an ungrounded motor/generator where the grounding of the system is assumed somewhere else.

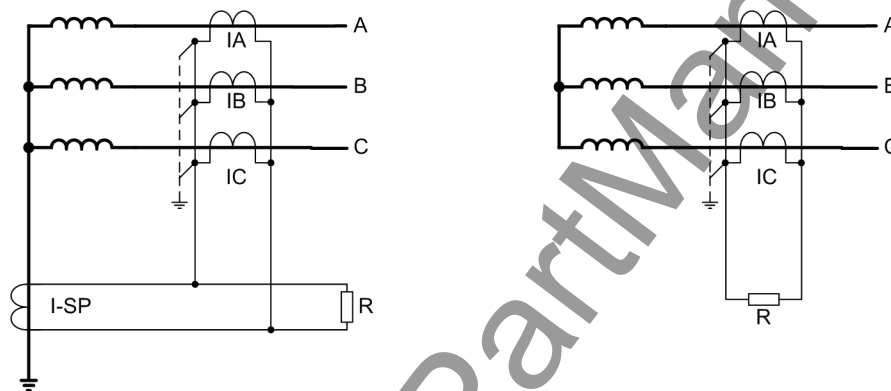

Figure 2-21 Ground fault protection according to the high-impedance principle

Function of the High-Impedance Principle

The high-impedance principle is explained on the basis of a grounded transformer winding.

No zero sequence current will flow during normal operation, i.e. the starpoint current is $I_{SP} = 0$ and the phase currents are $3 I_0 = I_A + I_B + I_C = 0$.

In case of an external ground fault (left in Figure 2-22), whose fault current is supplied via the grounded starpoint, the same current flows through the transformer starpoint and the phases. The corresponding secondary currents (all current transformers have the same transformation ratio) compensate each other; they are connected in series. Across resistor R only a small voltage is generated. It originates from the inner resistance of the transformers and the connecting cables of the transformers. Even if any current transformer experiences a partial saturation, it will become low-ohmic for the period of saturation and creates a low-ohmic shunt to the high-ohmic resistor R. Thus, the high resistance of the resistor also has a stabilizing effect (the so-called resistance stabilization).

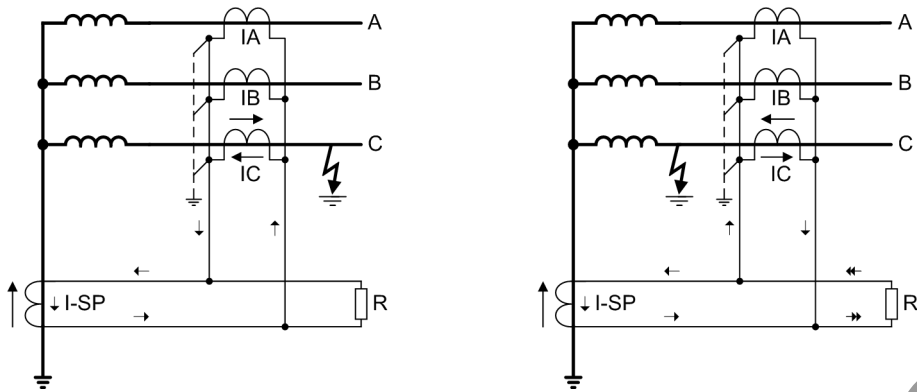

Figure 2-22 Principle of ground fault protection according to the high-impedance principle

When a ground fault occurs in the protected zone (Fig. 2-22 right), there is always a starpoint current I_{SP} . The grounding conditions in the rest of the network determine how strong a zero sequence current from the system is. A secondary current which is equal to the total fault current tries to pass through the resistor R. Since the latter is high-resistive, a high voltage emerges immediately. Therefore, the current transformers get saturated. The RMS voltage across the resistor approximately corresponds to the knee-point voltage of the current transformers.

Resistance R is dimensioned such that, even with the very lowest ground fault current to be detected, it generates a secondary voltage, which is equal to half the saturation voltage of current transformers (see also notes on "Dimensioning" in Subsection 2.4.4).

High-impedance Protection with 7SJ61

With 7SJ61 the sensitive measurement input I_{Ns} or alternatively the insensitive measurement input I_N is used for high-impedance protection. As this is a current input, the protection detects current through the resistor R instead of the voltage across the resistor R.

Figure 2-23 illustrates the connection scheme. The protection device is connected in series to resistor R and measures its current.

Varistor B limits the voltage when internal faults occur. High voltage peaks emerging with transformer saturation are cut by the varistor. At the same time, voltage is smoothed without reduction of the mean value.

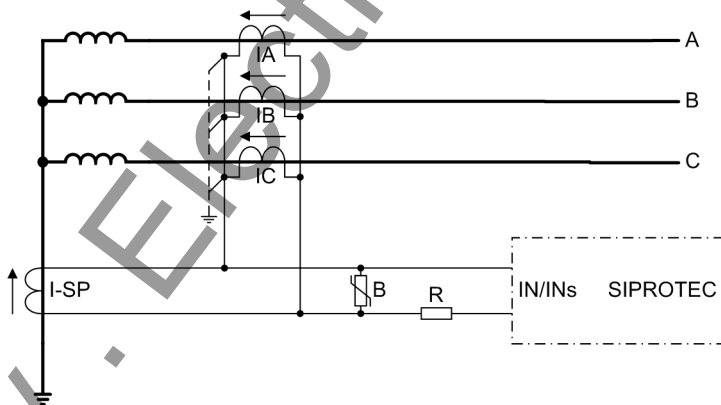

Figure 2-23 Connection diagram of the ground fault differential protection according to the high-impedance principle

For protection against overvoltages it is also important that the device is directly connected to the grounded side of the current transformers so that the high voltage at the resistor can be kept away from the device.

For generators, motors and shunt reactors high-impedance protection can be used analogously. All current transformers at the overvoltage side, the undervoltage side and the current transformer at the starpoint have to be connected in parallel when using auto-transformers.

In principle, this procedure can be applied to every protected object. When applied as busbar protection, for example, the device is connected to the parallel connection of all feeder current transformers via the resistor.

2.4.3 Tank Leakage Protection

Application Example

The tank leakage protection has the task to detect ground leakage — even high-ohmic — between a phase and the frame of a power transformer. The tank must be isolated from ground. A conductor links the tank to ground, and the current through this conductor is fed to a current input of the relay. When tank leakage occurs, a fault current (tank leakage current) will flow through the grounding conductor to ground. This tank leakage current is detected by the single-phase overcurrent protection as an overcurrent; an instantaneous or delayed trip command is issued in order to disconnect all sides of the transformer.

A high-sensitivity single-phase current input is used for tank leakage protection.

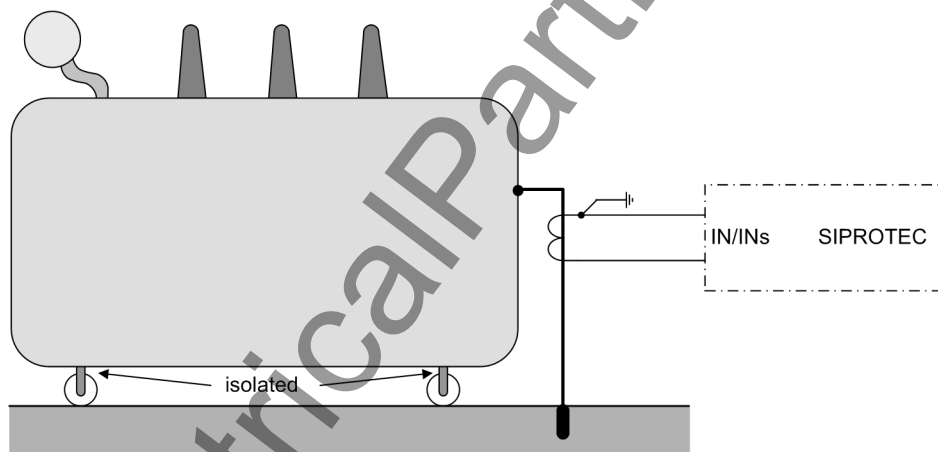

Figure 2-24 Principle of tank-leakage protection

2.4.4 Setting Notes

General

Single-phase time overcurrent protection can be set **ON** or **OFF** at address 2701 **50 1Ph**.

The settings are based on the particular application. The setting ranges depend on whether the current measuring input is a sensitive or a normal input transformer (see also „Ordering Information“ in Appendix A.1).

In case of a normal input transformer, set the pickup value for **50 1Ph-2 PICKUP** in address 2702, the pickup value for **50 1Ph-1 PICKUP** in address 2705. If only one element is required, set the one not required to ∞ .

In case of a sensitive input transformer, set the pickup value for **50 1Ph-2 PICKUP** in address 2703, the pickup value for **50 1Ph-1 PICKUP** in address 2706. If only one element is required, set the one not required to ∞ .

If you need a tripping time delay for the 50-2 elements, set it in address 2704 **50 1Ph-2 DELAY**, for the 50-1 element in address 2707 **50 1Ph-1 DELAY**. With setting 0 s no delay takes place.

The selected times are additional time delays and do not include the operating time (measuring time, etc.) of the elements. The delay can also be set to ∞ ; the corresponding element will then not trip after pickup, but the pickup is reported.

Special notes are given in the following for the use as high-impedance unit protection and tank leakage protection.

Application as High-impedance Protection

The application as high-impedance protection requires that starpoint current detection is possible in the system in addition to phase current detection (see example in Figure 2-23). Furthermore, a sensitive input transformer must be available at device input I_N/I_{NS} . In this case, only the pickup value for single-phase overcurrent protection is set at the 7SJ61 device for the current at input I_N/I_{NS} .

The entire function of high-impedance protection is, however, dependent on the interaction of current transformer characteristics, external resistor R and voltage across R. The following section gives information on this topic.

Current Transformer Data for High-impedance Protection

All current transformers must have an identical transformation ratio and nearly equal knee-point voltage. This is usually the case if they are of equal design and identical rated data. The knee-point voltage can be approximately calculated from the rated data of a CT as follows:

$$V_{KPV} = \left(R_I - \frac{P_{Nom}}{I_{Nom}^2} \right) \cdot n \cdot I_{Nom}$$

- V_{KPV} Knee-point voltage
- R_I Internal burden of the CT
- P_{Nom} Nominal power of the CT
- I_{Nom} Secondary nominal current of CT
- ALF Rated accuracy limit factor of the CT

The nominal current, nominal power and accuracy limit factor are normally stated on the rating plate of the current transformer, e.g.

Current transformer 800/5; 5P10; 30 VA

That means

$$\begin{aligned} I_{\text{Nom}} &= 5 \text{ A (from 800/5)} \\ \text{ALF} &= 10 \text{ (from 5P10)} \\ P_{\text{Nom}} &= 30 \text{ VA} \end{aligned}$$

The internal burden is often stated in the test report of the current transformer. If not, it can be derived from a DC measurement on the secondary winding.

Calculation Example:

CT 800/5; 5P10; 30 VA with $R_i = 0.3 \Omega$

$$V_{\text{KPV}} = \left(R_i - \frac{P_{\text{Nom}}}{I_{\text{Nom}}^2} \right) \cdot n \cdot I_{\text{Nom}} - \left(0.3 \Omega + \frac{30 \text{ VA}}{(5 \text{ A})^2} \right) \cdot 10 \cdot 5 \text{ A} = 75 \text{ V}$$

or

CT 800/1; 5P10; 30 VA with $R_i = 5 \Omega$

$$V_{\text{KPV}} = \left(R_i - \frac{P_{\text{Nom}}}{I_{\text{Nom}}^2} \right) \cdot n \cdot I_{\text{Nom}} - \left(5 \Omega + \frac{30 \text{ VA}}{(1 \text{ A})^2} \right) \cdot 10 \cdot 1 \text{ A} = 350 \text{ V}$$

Besides the CT data, the resistance of the longest connection lead between the CTs and the 7SJ61 device must be known.

Stability with High-impedance Protection

The stability condition is based on the following simplified assumption: If there is an external fault, **one** of the current transformers gets totally saturated. The other ones will continue transmitting their (partial) currents. In theory, this is the most unfavorable case. Since, in practice, it is also the saturated transformer which supplies current, an automatic safety margin is guaranteed.

Figure 2-25 shows a simplified equivalent circuit. CT1 and CT2 are assumed as ideal transformers with their inner resistances R_{i1} and R_{i2} . R_a are the resistances of the connecting cables between current transformers and resistor R. They are multiplied by 2 as they have a forward and a return line. R_{a2} is the resistance of the longest connecting cable.

CT1 transmits current I_1 . CT2 shall be saturated. Because of saturation the transformer represents a low-resistance shunt which is illustrated by a dashed short-circuit line.

$R \gg (2R_{a2} + R_{i2})$ is a further prerequisite.

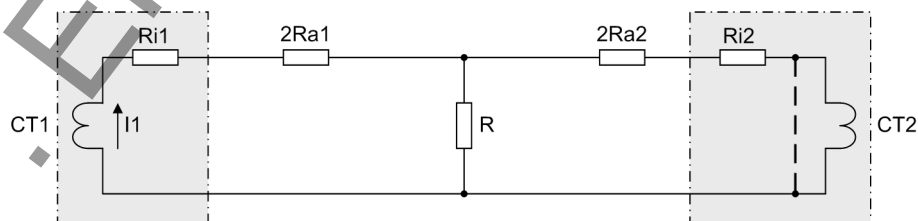

Figure 2-25 Simplified equivalent circuit of a circulating current system for high-impedance protection

The voltage across R is then

$$V_R = I_1 \cdot (2R_{a2} + R_{i2})$$

It is assumed that the pickup value of the 7SJ61 corresponds to half the knee-point voltage of the current transformers. In the balanced case results

$$V_R = V_{KPV} / 2$$

This results in a stability limit I_{SL} , i.e. the maximum through-fault current below which the scheme remains stable:

$$I_{SL} = \frac{V_{KPV}/2}{2 \cdot R_{a2} + R_{i2}}$$

Calculation Example:

For the 5 A CT as above with $V_{KPV} = 75$ V and $R_i = 0.3 \Omega$

longest CT connection lead 22 m (24.06 yd) with 4 mm² cross-section; this corresponds to $R_a = 0.1 \Omega$

$$I_{SL} = \frac{V_{KPV}/2}{2 \cdot R_{a2} + R_{i2}} = \frac{37.5 \text{ V}}{2 \cdot 0.1 \Omega + 0.3 \Omega} = 75 \text{ A}$$

that is 15 × rated current or 12 kA primary.

For the 1 A CT as above with $V_{KPV} = 350$ V and $R_i = 5 \Omega$

longest CT connection lead 107 m (117.02 yd) with 2.5 mm² cross-section, results in $R_a = 0.75 \Omega$

$$I_{SL} = \frac{V_{KPV}/2}{2 \cdot R_{a2} + R_{i2}} = \frac{175 \text{ V}}{2 \cdot 0.75 \Omega + 5 \Omega} = 27 \text{ A}$$

that is 27 × rated current or 21.6 kA primary.

Sensitivity with High-impedance Protection

The voltage present at the CT set is forwarded to the protective relay across a series resistor R as proportional current for evaluation. The following considerations are relevant for dimensioning the resistor:

As already mentioned, it is desired that the high-impedance protection should pick up at half the knee-point voltage of the CT's. The resistor R can be calculated on this basis.

Since the device measures the current flowing through the resistor, resistor and measuring input of the device must be connected in series. Since, furthermore, the resistance shall be high-resistance (condition: $R \gg 2R_{a2} + R_{i2}$, as mentioned above), the inherent resistance of the measuring input can be neglected. The resistance is then calculated from the pickup current I_{pu} and half the knee-point voltage:

$$R = \frac{V_{KPV}/2}{I_{pu}}$$

Calculation Example:

For the 5 A CT as above

desired pickup value $I_{pu} = 0.1$ A (equivalent to 16 A primary)

$$R = \frac{V_{KPV}^2}{I_{pu}^2} = \frac{75 \text{ V}^2}{0.1 \text{ A}^2} = 375 \Omega$$

For the 1 A CT as above

desired pickup value $I_{pu} = 0.05$ A (equivalent to 40 A primary)

$$R = \frac{V_{KPV}^2}{I_{pu}^2} = \frac{350 \text{ V}^2}{0.05 \text{ A}^2} = 3500 \Omega$$

The required short-term power of the resistor is derived from the knee-point voltage and the resistance:

$$P_R = \frac{V_{KPV}^2}{R} = \frac{(75 \text{ V})^2}{375 \Omega} = 15 \text{ W} \quad \text{for the 5 A CT example}$$

$$P_R = \frac{V_{KPV}^2}{R} = \frac{(350 \text{ V})^2}{3500 \Omega} = 35 \text{ W} \quad \text{for the 1 A CT example}$$

As this power only appears during ground faults for a short period of time, the rated power can be smaller by approx. factor 5.

Please bear in mind that when choosing a higher pickup value I_{pu} , the resistance must be decreased and, in doing so, power loss will increase significantly.

The varistor B (see following figure) must be dimensioned such that it remains high-resistive until reaching knee-point voltage, e.g.

approx. 100 V for 5 A CT,

approx. 500 V for 1 A CT.

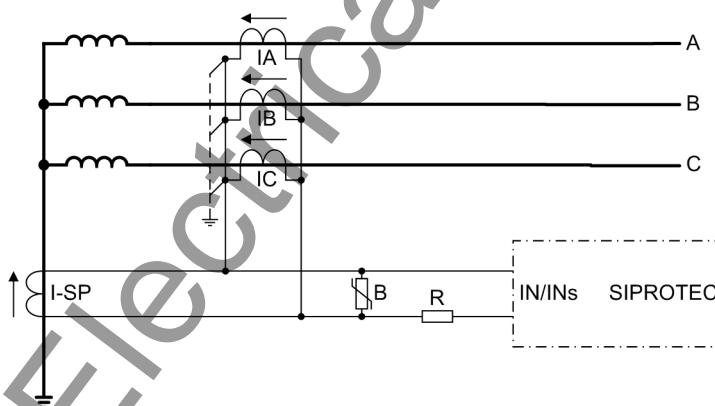

Figure 2-26 Connection diagram of the ground fault differential protection according to the high-impedance principle

Even with an unfavorable external circuit, the maximum voltage peaks should not exceed 2 kV for safety reasons.

If performance makes it necessary to switch several varistors in parallel, preference should be given to types with a flat characteristic to avoid asymmetrical loading. therefore recommend the following types from METROSIL:

600A/S1/S256 ($k = 450$, $\beta = 0.25$)

600A/S1/S1088 ($k = 900$, $\beta = 0.25$)

The pickup value (0.1 A or 0.05 A in the example) is set in address 2706 **50 1Ph-1 PICKUP** in the device. The 50-2 element is not required (address 2703 **50 1Ph-2 PICKUP** = ∞).

The trip command of the protection can be delayed via address 2707 **50 1Ph-1 DELAY**. Normally, such delay is set to **0**.

If a higher number of CTs is connected in parallel, e.g. as busbar protection with several feeders, the magnetizing currents of the transformers connected in parallel cannot be neglected anymore. In this case, the magnetizing currents at half the knee-point voltage (corresponds to the setting value) have to be summed up. These magnetizing currents reduce the current through the resistor R. Therefore the actual pickup value will be correspondingly higher.

Application as Tank Leakage Protection

The use as tank leakage protection requires that a sensitive input transformer is available at the device input I_N/I_{NS} . In this case, only the pickup value for single phase overcurrent protection is set at the 7SJ61 device for the current at input I_N/I_{NS} .

The tank leakage protection is a sensitive overcurrent protection which detects the leakage current between the isolated transformer tank and ground. Its sensitivity is set in address 2706 **50 1Ph-1 PICKUP**. The 50-2 element is not required (address 2703 **50 1Ph-2 PICKUP** = ∞).

The trip command of the element can be delayed in address 2707 **50 1Ph-1 DELAY**. It is normally set to **0**.



Note

In the following settings, addresses 2703 and 2706 are valid for a highly sensitive current measuring input independently of the nominal current.

2.4.5 Settings

The table indicates region-specific default settings. Column C (configuration) indicates the corresponding secondary nominal current of the current transformer.

Addr.	Parameter	C	Setting Options	Default Setting	Comments
2701	50 1Ph		OFF ON	OFF	50 1Ph
2702	50 1Ph-2 PICKUP	1A	0.05 .. 35.00 A; ∞	0.50 A	50 1Ph-2 Pickup
		5A	0.25 .. 175.00 A; ∞	2.50 A	
2703	50 1Ph-2 PICKUP		0.003 .. 1.500 A; ∞	0.300 A	50 1Ph-2 Pickup
2704	50 1Ph-2 DELAY		0.00 .. 60.00 sec; ∞	0.10 sec	50 1Ph-2 Time Delay
2705	50 1Ph-1 PICKUP	1A	0.05 .. 35.00 A; ∞	0.20 A	50 1Ph-1 Pickup
		5A	0.25 .. 175.00 A; ∞	1.00 A	
2706	50 1Ph-1 PICKUP		0.003 .. 1.500 A; ∞	0.100 A	50 1Ph-1 Pickup
2707	50 1Ph-1 DELAY		0.00 .. 60.00 sec; ∞	0.50 sec	50 1Ph-1 Time Delay

2.4.6 Information List

No.	Information	Type of Information	Comments
5951	>BLK 50 1Ph	SP	>BLOCK 50 1Ph
5952	>BLK 50 1Ph-1	SP	>BLOCK 50 1Ph-1
5953	>BLK 50 1Ph-2	SP	>BLOCK 50 1Ph-2
5961	50 1Ph OFF	OUT	50 1Ph is OFF
5962	50 1Ph BLOCKED	OUT	50 1Ph is BLOCKED
5963	50 1Ph ACTIVE	OUT	50 1Ph is ACTIVE
5966	50 1Ph-1 BLK	OUT	50 1Ph-1 is BLOCKED
5967	50 1Ph-2 BLK	OUT	50 1Ph-2 is BLOCKED
5971	50 1Ph Pickup	OUT	50 1Ph picked up
5972	50 1Ph TRIP	OUT	50 1Ph TRIP
5974	50 1Ph-1 PU	OUT	50 1Ph-1 picked up
5975	50 1Ph-1 TRIP	OUT	50 1Ph-1 TRIP
5977	50 1Ph-2 PU	OUT	50 1Ph-2 picked up
5979	50 1Ph-2 TRIP	OUT	50 1Ph-2 TRIP
5980	50 1Ph.I:	VI	50 1Ph: I at pick up

2.5 Negative Sequence Protection 46

Negative sequence protection detects unbalanced loads on the system.

Applications

- The application of unbalanced load protection to motors has a special significance. Unbalanced loads create counter-rotating fields in three-phase induction motors, which act on the rotor at double frequency. Eddy currents are induced at the rotor surface, and local overheating in rotor end zones and the slot wedge begins to take place. This especially goes for motors which are tripped via vacuum contactors with fuses connected in series. With single-phasing by fuse pickup the motor only generates small and pulsing moments such that it soon gets strained thermally assuming, however, that the driven machine requires the same amount of moments. In addition, with unbalanced supply voltage it is endangered by thermal overload. Due to the small negative sequence reactance even small voltage asymmetries lead to negative sequence currents.
- In addition, this protection function may be used to detect interruptions, short circuits and polarity problems with current transformers.
- It is also useful in detecting single-pole and two-pole faults with fault currents lower than the maximum load currents.

Prerequisites

The unbalanced load protection becomes effective when:

a minimum phase current is larger than $0.1 \times I_{Nom}$ and

all phase currents are smaller than $10 \times I_{Nom}$.

2.5.1 Definite Time Characteristic

The definite time characteristic consists of two elements. As soon as the first settable threshold 46-1 PICKUP is reached, a pickup message is output and time element 46-1 DELAY is started. When the second element 46-2 PICKUP is started, another message is output and time element 46-2 DELAY is initiated. Once either time delay elapses, a trip signal is initiated.

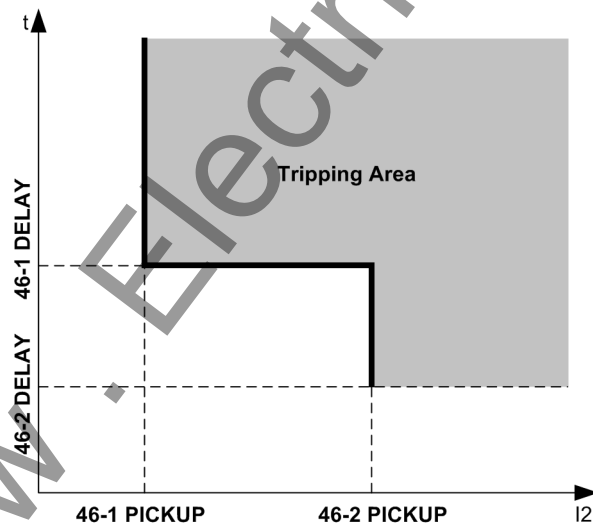

Figure 2-27 Definite time characteristic for negative sequence protection

Settable Dropout Times

Pickup stabilization for the definite-time tripping characteristic 46-1, 46-2 can be accomplished by means of settable dropout times. This facility is used in power systems with possible intermittent faults. Used together with electromechanical relays, it allows different dropout responses to be adjusted and time grading of digital and electromechanical relays to be implemented.

2.5.2 Inverse Time Characteristic 46-TOC

The inverse time element is dependent on the ordered device version. It operates with IEC or ANSI characteristic tripping curves. The curves and associated formulas are given in the Technical Data. When programming the inverse time characteristic also definite time elements 46-2 PICKUP and 46-1 PICKUP are available (see foregoing paragraph).

Pickup and Tripping

The negative sequence current I_2 is compared to the setting value **46-TOC PICKUP**. When the negative sequence current exceeds 1.1 times the setting value, a pickup annunciation is generated. The tripping time is calculated from the negative sequence current according to the characteristic selected. After expiration of the time period a tripping command is output. The characteristic curve is illustrated in the following figure.

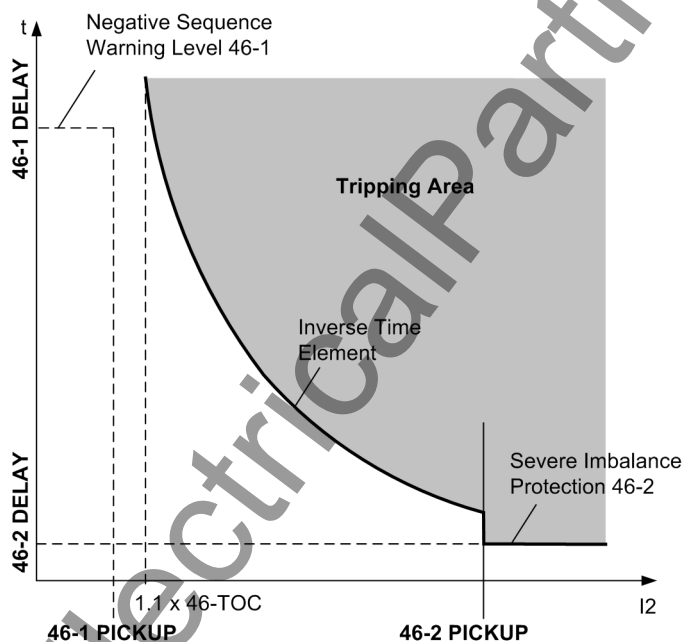

Figure 2-28 Inverse time characteristic for negative sequence protection

Dropout for IEC Curves

The element drops out when the negative sequence current decreases to approx. 95% of the pickup setting. The time delay resets immediately in anticipation of another pickup.

Dropout for ANSI Curves

When using an ANSI curve, select if dropout after pickup is instantaneous or with disk emulation. "Instantaneous" means that pickup drops out when the pickup value of approx. 95 % is undershot. For a new pickup the time delay starts at zero.

The disk emulation evokes a dropout process (timer counter is decrementing) which begins after de-energization. This process corresponds to the reset of a Ferraris-disk (explaining its denomination "disk emulation"). In case several faults occur in succession the "history" is taken into consideration due to the inertia of the Ferraris-disk and the time response is adapted. This ensures a proper simulation of the temperature rise of the protected object even for extremely fluctuating unbalanced load values. Reset begins as soon as 90 % of the setting value is undershot, in accordance with the dropout curve of the selected characteristic. In the range between the dropout value (95 % of the pickup value) and 90 % of the setting value, the incrementing and the decrementing process is in idle state.

Disk emulation offers advantages when the behavior of the negative sequence protection must be coordinated with other relays in the system based on electromagnetic measuring principles.

Logic

The following figure shows the logic diagram for the negative sequence protection function. The protection may be blocked via a binary input. This resets pickup and time elements and clears measured values.

When the negative sequence protection criteria are no longer satisfied (i.e. all phase currents below $0.1 \times I_{Nom}$ or at least one phase current is greater than $10 \times I_{Nom}$) all pickups issued by the negative sequence protection function are reset.

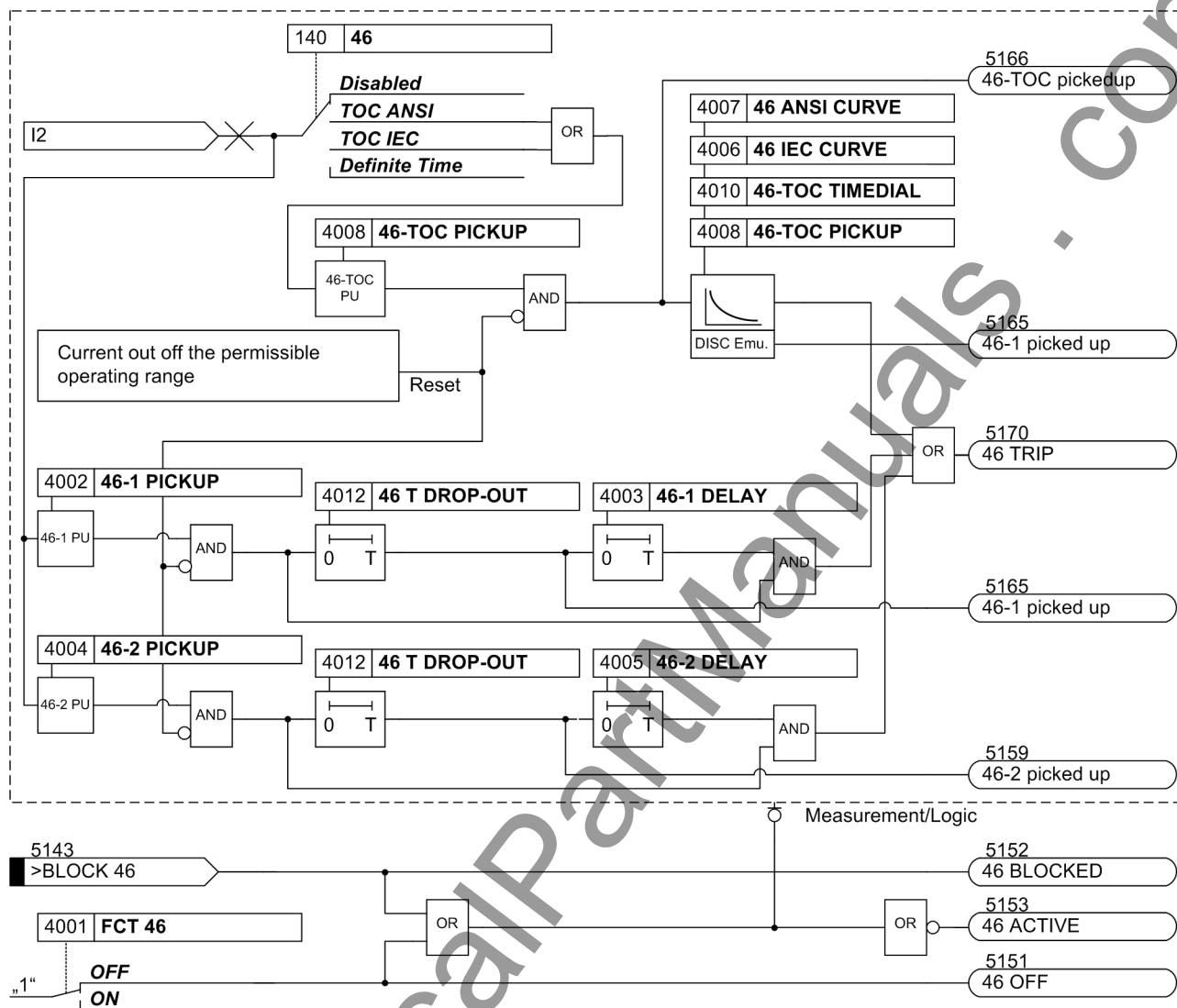

Figure 2-29 Logic diagram of the unbalanced load protection

The pickup of the definite time overcurrent protection can be stabilized by the configured dropout time 4012 **46 T DROP-OUT**. This time is started and maintains the pickup condition if the current falls below the threshold. Therefore, the function does not drop out at high speed. The trip command delay time continues running. After the dropout delay time has elapsed, the pickup is reported OFF and the trip delay time is reset unless the threshold has been exceeded again. If the threshold is exceeded again during the dropout delay time, the time is cancelled. The trip command delay time continues running. Should the threshold value be exceeded after its expiry, the trip command is issued immediately. If the threshold value is not exceeded at this time, there will be no reaction. If the threshold value is exceeded again after expiry of the trip-command delay time, while the dropout delay time is still running, tripping occurs immediately.

The configured dropout times do not influence the tripping times of the inverse time elements as these depend dynamically on the measured current value. For purposes of dropout coordination, disc emulation is used with electro-mechanical relays.

2.5.3 Setting Notes

General

The function type has been specified during configuration of the protection functions (Section 2.1.1.2, address 140 **46**). If only the definite time elements are desired, the address **46** should be set to **Definite Time**. Selecting **46 = TOC IEC** or **TOC ANSI** in address 140 will additionally make all parameters available that are relevant for the inverse time curves. If this function is not required, then **Disabled** is set.

The function can be turned **ON** or **OFF** in address 4001 **FCT 46**.

The default pickup settings and delay settings are generally sufficient for most applications. If data is available from the manufacturer regarding the allowable long-term load imbalance and the allowable load imbalance per unit of time, this data should be used preferentially. It is important to note that the manufacturer's data relate to the primary values of the machine, for example, the maximum permissible permanent inverse current is referred to the nominal machine current. For the setting values at the protection device, this information is converted to the secondary inverse current. The following applies

$$\text{Pickup Setting} \quad I_2 = \left(\frac{I_{2\text{perm prim}}}{I_{\text{NomMotor}}} \right) \cdot I_{\text{NomMotor}} \cdot \frac{I_{\text{CT sec}}}{I_{\text{CT prim}}}$$

with

- $I_{2\text{perm prim}}$ permissible thermal inverse current of the motor
- $I_{\text{Nom Motor}}$ Nominal Motor Current
- $I_{\text{CT sec}}$ Secondary Nominal Current of the Current Transformer
- $I_{\text{CT prim}}$ Primary nominal current of the current transformer

Definite Time Elements

The unbalanced load protection function comprises elements. Therefore, the upper element (address 4004 **46-2 PICKUP**) can be set to a short time delay (address 4005 **46-2 DELAY**) and the lower element (address 4002 **46-1 PICKUP**) can be set to a somewhat longer time delay (address 4003 **46-1 DELAY**). This allows the lower element to act, e.g. as an alarm, while the upper element will cut the inverse characteristic as soon as high inverse currents are present. If **46-2 PICKUP** is set to about 60%, tripping is always performed with the thermal characteristic. On the other hand, with more than 60 % of unbalanced load the user will assume a phase-to-phase fault. The delay time **46-2 DELAY** must be coordinated with the system grading for phase-to-phase faults. If power supply with current I is provided via just two phases, the following applies to the inverse current:

$$I_2 = \frac{1}{\sqrt{3}} \cdot I = 0.58 \cdot I$$

Examples:

Motor with the following data:

Nominal current	$I_{Nom\ Motor} = 545\ A$
Continuously permissible negative sequence current	$I_{2\ dd\ prim} / I_{Nom\ Motor} = 0.11\ continuous$
Briefly permissible negative sequence current	$I_{2\ long-term\ prim} / I_{Nom\ Motor} = 0.55\ for\ T\ max = 1\ s$
Current transformer	$I_{Nomprim} / I_{Nomsec} = 600\ A / 1\ A$
Setting value	46-1 Pickup = $0.11 \cdot 545\ A \cdot (1/600\ A) = 0.10\ A$
Setting value	46-2 Pickup = $0.55 \cdot 545\ A \cdot (1/600\ A) = 0.50\ A$

When protecting feeder or cable systems, unbalanced load protection may serve to identify low magnitude unsymmetrical faults below the pickup values of the directional and non-directional overcurrent elements.

Here, the following must be observed:

$$I_2 = \frac{1}{\sqrt{3}} \cdot I = 0.58 \cdot I$$

A phase-to-ground fault with current I corresponds to the following negative sequence current:

$$I_2 = \frac{1}{3} \cdot I = 0.33 \cdot I$$

On the other hand, with more than 60% of unbalanced load, a phase-to-phase fault can be assumed. The delay time **46-2 DELAY** must be coordinated with the system grading of phase-to-phase faults.

For a power transformer, unbalanced load protection may be used as sensitive protection for low magnitude phase-to-ground and phase-to-phase faults. In particular, this application is well suited for delta-wye transformers where low side phase-to-ground faults do not generate high side zero sequence currents (e.g. vector group Dy).

Since transformers transform symmetrical currents according to the transformation ratio "CTR", the relationship between negative sequence currents and total fault current for phase-to-phase faults and phase-to-ground faults are valid for the transformer as long as the turns ratio "CTR" is taken into consideration.

Consider a transformer with the following data:

Base Transformer Rating	$S_{NomT} = 16\ MVA$
Primary Nominal Voltage	$V_{Nom} = 110\ kV$
Secondary Nominal Voltage	$V_{Nom} = 20\ kV \quad (TR_V = 110/20)$
Vector Groups	Dy5
High Side CT	$100\ A / 1\ A \quad (CT_I = 100)$

The following fault currents may be detected at the low side:

If **46-1 PICKUP** on the high side of the devices is set to = 0.1, then a fault current of $I = 3 \cdot TR_V \cdot TR_I \cdot 46-1 \text{ PICKUP} = 3 \cdot 110/20 \cdot 100 \cdot 0.1 \text{ A} = 165 \text{ A}$ for single-phase faults and $\sqrt{3} \cdot TR_V \cdot TR_I \cdot 46-1 \text{ PICKUP} = 95 \text{ A}$ can be detected for two-phase faults at the low side. This corresponds to 36% and 20% of the transformer nominal current respectively. It is important to note that load current is not taken into account in this simplified example.

As it cannot be recognized reliably on which side the thus detected fault is located, the delay time **46-1 DELAY** must be coordinated with other downstream relays in the system.

Pickup Stabilization (Definite Time)

Pickup of the definite time elements can be stabilized by means of a configurable dropout time. This dropout time is set in 4012 **46 T DROP-OUT**.

IEC Curves (Inverse Time Tripping Curve)

The thermal behavior of a machine can be closely replicated due to negative sequence by means of an inverse time tripping curve. In address 4006 **46 IEC CURVE**, select out of three IEC curves provided by the device the curve which is most similar to the thermal unbalanced load curve provided by the manufacturer. The tripping curves of the protective relay, and the formulas on which they are based, are given in the Technical Data.

It must be noted that a safety factor of about 1.1 has already been included between the pickup value and the setting value when an inverse time characteristic is selected. This means that a pickup will only occur if an unbalanced load of about 1.1 times the setting value **46-TOC PICKUP** is present (address 4008). The dropout is performed as soon as the value falls below 95% of the pickup value.

The associated time multiplier is entered at address 4010, **46-TOC TIMEDIAL**.

The time multiplier can also be set to ∞ . After pickup the element will then not trip. Pickup, however, will be signaled. If the inverse time element is not required at all, address 140 **46** should be set to **Definite Time** during the configuration of protection functions (Section 2.1.1.2).

ANSI Curves (Inverse Time Tripping Curve)

Behavior of a machine due to negative sequence current can be closely replicated by means of an inverse time tripping curve. In address 4007 the **46 ANSI CURVE**, select out of four ANSI curves provided by the device the curve which is most similar to the thermal unbalanced load curve provided by the manufacturer. The tripping curves of the protective relay, and the formulas on which they are based, are given in the Technical Data.

It must be noted that a safety factor of about 1.1 has already been included between the pickup value and the setting value when an inverse time characteristic is selected. This means that a pickup will only occur if an unbalanced load of about 1.1 times the setting value is present. If **Disk Emulation** was selected at address 4011 **46-TOC RESET**, reset will occur in accordance with the reset curve as described in the Functional Description.

The unbalanced load value is set at address 4008 **46-TOC PICKUP**. The corresponding time multiplier is accessible via address 4009 **46-TOC TIMEDIAL**.

The time multiplier can also be set to ∞ . In this case, the element will not trip after pickup. However, pickup, will be signaled. If the inverse time element is not required at all, address 140 **46** should be set to **Definite Time** during configuration of the protection functions (Section 2.1.1.2).

2.5.4 Settings

Addresses which have an appended "A" can only be changed with DIGSI, under "Display Additional Settings".

The table indicates region-specific default settings. Column C (configuration) indicates the corresponding secondary nominal current of the current transformer.

Addr.	Parameter	C	Setting Options	Default Setting	Comments
4001	FCT 46		OFF ON	OFF	46 Negative Sequence Protection
4002	46-1 PICKUP	1A	0.10 .. 3.00 A	0.10 A	46-1 Pickup
		5A	0.50 .. 15.00 A	0.50 A	
4003	46-1 DELAY		0.00 .. 60.00 sec; ∞	1.50 sec	46-1 Time Delay
4004	46-2 PICKUP	1A	0.10 .. 3.00 A	0.50 A	46-2 Pickup
		5A	0.50 .. 15.00 A	2.50 A	
4005	46-2 DELAY		0.00 .. 60.00 sec; ∞	1.50 sec	46-2 Time Delay
4006	46 IEC CURVE		Normal Inverse Very Inverse Extremely Inv.	Extremely Inv.	46 IEC Curve
4007	46 ANSI CURVE		Extremely Inv. Inverse Moderately Inv. Very Inverse	Extremely Inv.	46 ANSI Curve
4008	46-TOC PICKUP	1A	0.10 .. 2.00 A	0.90 A	46-TOC Pickup
		5A	0.50 .. 10.00 A	4.50 A	
4009	46-TOC TIMEDIAL		0.50 .. 15.00 ; ∞	5.00	46-TOC Time Dial
4010	46-TOC TIMEDIAL		0.05 .. 3.20 sec; ∞	0.50 sec	46-TOC Time Dial
4011	46-TOC RESET		Instantaneous Disk Emulation	Instantaneous	46-TOC Drop Out
4012A	46 T DROP-OUT		0.00 .. 60.00 sec	0.00 sec	46 Drop-Out Time Delay

2.5.5 Information List

No.	Information	Type of Information	Comments
5143	>BLOCK 46	SP	>BLOCK 46
5151	46 OFF	OUT	46 switched OFF
5152	46 BLOCKED	OUT	46 is BLOCKED
5153	46 ACTIVE	OUT	46 is ACTIVE
5159	46-2 picked up	OUT	46-2 picked up
5165	46-1 picked up	OUT	46-1 picked up
5166	46-TOC pickedup	OUT	46-TOC picked up
5170	46 TRIP	OUT	46 TRIP
5171	46 Dsk pickedup	OUT	46 Disk emulation picked up

2.6 Motor Protection

For the protection of motors, devices 7SJ61 are provided with a motor starting protection function, a restart inhibit and a load jam protection. The starting protection function protects the motor from prolonged startup procedures thus supplementing the overload protection (see Section 2.7). The restart inhibit prevents restarting of the motor when this restart may cause the permissible thermal limits of the rotor to be exceeded. The load jam protection serves to protect the motor during sudden rotor blocking.

2.6.1 Motor Starting Protection 48

When devices 7SJ61 are used to protect a motor, the starting protection feature supplements the overload protection and protects the motor against prolonged starting operations (see Section 2.7).

2.6.1.1 Description

General

In particular, rotor-critical high-voltage motors can quickly be heated above their thermal limits when multiple starting attempts occur in a short period of time. If the durations of these starting attempts are lengthened e.g. by excessive voltage surges during motor starting, by excessive load moments, or by blocked rotor conditions, a trip signal will be initiated by the protective relay.

Motor starting is detected when a settable current threshold **I MOTOR START** is exceeded. Calculation of the tripping time is then initiated. It should be noted that this timer starts every time the motor is started. This is therefore a normal operating condition that is neither indicated in the fault log nor causes the creation of a fault record. Only when the locked rotor time has elapsed is the trip command issued.

The protection function consists of one definite time and one inverse time tripping element.

Inverse Time Overcurrent Element

The inverse time overcurrent element is designed to operate only when the rotor is not blocked. With a decreased startup current resulting from voltage dips when starting the motor, prolonged startup times are evaluated correctly and tripping with an appropriate time is enabled. The characteristic (see formula below) can be ideally adjusted to the condition of the motor by using different startup times depending on the cold or warm condition of the motor (see Figure 2-30).

The tripping time is calculated based on the following equation:

$$t_{TRIP} = \left(\frac{I_{STARTUP}}{I} \right)^2 \cdot t_{Max.STARTUP} \quad \text{where } I > I_{MOTOR START}$$

with

- t_{TRIP} Actual tripping time for flowing current I
- $t_{max STARTUP}$ Tripping time for nominal startup current $I_{STARTUP}$ (address 4103, **STARTUP TIME** or 4105, **STARTUP T WARM**)
- I Current actually flowing (measurement value)
- $I_{STARTUP}$ Nominal startup current of the motor (address 4102, **STARTUP CURRENT**)
- $I_{MOTOR START}$ Pickup value for recognition of motor startup (address 1107, **I MOTOR START**),

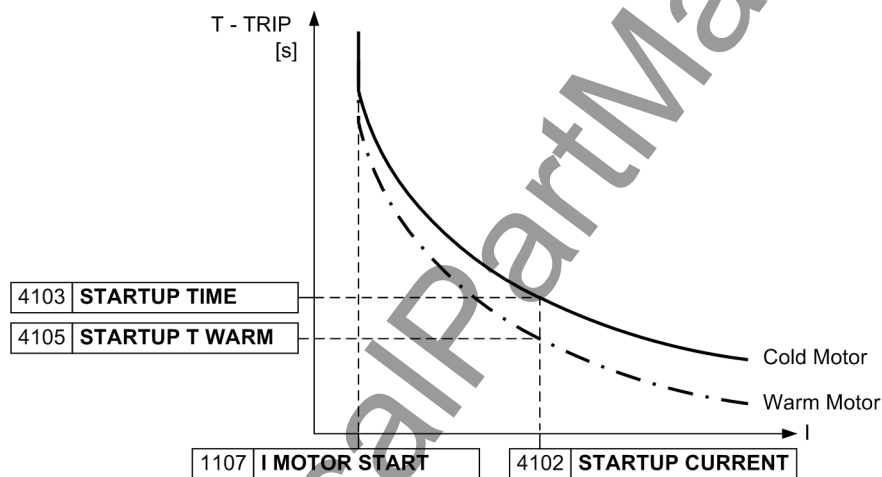

Figure 2-30 Inverse time tripping curve for motor starting current

Therefore, if the startup current I is smaller (larger) than the nominal current $I_{STARTUP}$ (parameter **STARTUP CURRENT**) as configured under address 4102, then the actual tripping time t_{TRIP} is prolonged (or shortened) accordingly (see Figure 2-30).

Definite Time Overcurrent Tripping Characteristic (Locked Rotor Time)

Tripping must be executed when the actual motor starting time exceeds the maximum allowable locked rotor time if the rotor is locked. The device can be informed about the locked rotor condition via the binary input („>Rotor locked“), e.g. from an external r.p.m. monitor. The motor startup condition is assumed when the current in any phase exceeds the current threshold **I MOTOR START**. At this instant, the timer LOCK ROTOR TIME is started.

The locked rotor delay time (**LOCK ROTOR TIME**) is linked to a binary input „>Rotor locked“ via an AND gate. If the binary input is picked up after the set locked rotor time has expired, immediate tripping will take place regardless of whether the locked rotor condition occurred before, during or after the timeout.

Logic

Motor starting protection may be switched on or off. In addition, motor starting protection may be blocked via a binary input which will reset timers and pickup annunciations. The following figure illustrates the logic of motor starting protection. A pickup does not create messages in the trip log buffer. Fault recording is not started until a trip command has been issued. When the function drops out, all timers are reset. The annunciations disappear and a trip log is terminated should it have been created.

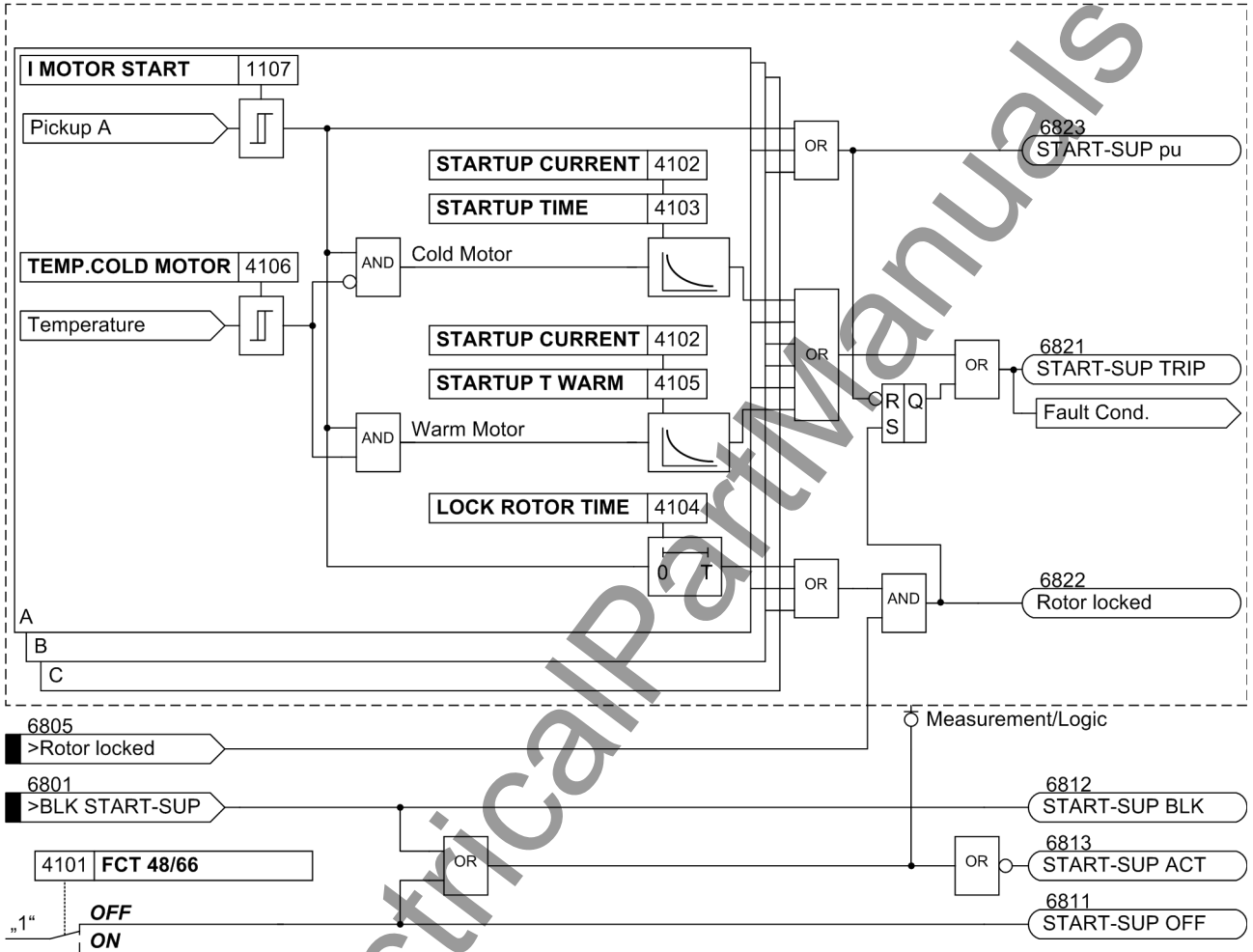

Figure 2-31 Logic diagram of the Motor Starting Protection

Switching of Startup Times

The motor manufacturer provides startup time curves for both cold and warm motor conditions (see Figure 2-30). The function Motor Starting Protection automatically performs a switching. The "warm motor" condition is derived from the thermal storage of the restart inhibit (see Section 2.6.2). Therefore, this function must be enabled. The condition for the switching is determined by the parameter 4106 **TEMP . COLD MOTOR**. If the motor temperature (actually the rotor temperature) exceeds the threshold value, then a switching from "cold motor" to "warm motor" takes place (see logic diagram 2-31). The threshold values can be derived from the permitted number of cold (n_{cold}) and warm (n_{warm}) motor startups. By means of the following formula an approximate limit value can be determined.

$$\Theta_{\text{limit}} = \frac{n_{\text{cold}} - n_{\text{warm}}}{n_{\text{cold}}} \cdot 100 \% \text{ MOTOR}$$

The setting value should always be lower than the limit value (see Setting Notes 2.6.1.2).

2.6.1.2 Setting Notes

General

Motor starting protection is only effective and accessible if address 141 **48 = Enabled** is set. If the function is not required **Disabled** is set. The function can be turned **ON** or **OFF** under address 4101 **48**.

Startup Parameter

The device is informed of the startup current values under normal conditions at address 4102 **STARTUP CURRENT**, the startup time at address 4103 **STARTUP TIME**. At all times this enables timely tripping if the value I^2t calculated in the protection device is exceeded.

If the startup time is longer than the permissible blocked rotor time, an external rpm-counter can initiate the definite-time tripping characteristic via binary input („>Rotor Locked“). A locked rotor leads to a loss of ventilation and therefore to a reduced thermal load capacity of the machine. For this reason, the motor starting time function is to issue a tripping command before reaching the thermal tripping characteristic valid for normal operation.

A current above the current threshold 1107 **I MOTOR START** is interpreted as motor startup. Consequently, this value must be chosen such that it is reliably attained by the actual starting current under any load or voltage conditions during motor startup, but not during a permissible short-time overload.

Example: Motor with the following data:

Rated Voltage	$V_{\text{Nom}} = 6600 \text{ V}$
Nominal current	$I_{\text{MOTNom}} = 126 \text{ A}$
Startup current (primary)	$I_{\text{STARTUPw}} = 624 \text{ A}$
Long-term current rating	$I_{\text{max}} = 135 \text{ A}$
Startup time (cold condition)	$T_{\text{TMax.STARTUPc}} = 15 \text{ s}$
Startup time (warm condition)	$T_{\text{TMax.STARTUPw}} = 8.5 \text{ s}$
Current transformer	$I_{\text{NomCTprim}} / I_{\text{NomCTsec}} = 200 \text{ A} / 1 \text{ A}$

The setting for address **STARTUP CURRENT** (I_{STARTUP}) as a secondary value is calculated as follows:

$$I_{\text{STARTUP sec}} = \frac{I_{\text{STARTUP}}}{I_{\text{Nom CT prim}}} \cdot I_{\text{Nom CT sec}} = \frac{624 \text{ A}}{200 \text{ A}} \cdot I_{\text{Nom CT sec}} = 3.12 \text{ A}$$

For reduced voltage, the startup current is also reduced almost linearly. At 80 % nominal voltage, the startup current in this example is reduced to $0.8 \cdot I_{\text{STARTUP}} = 2.5$.

The setting for detection of a motor startup must lie above the maximum load current and below the minimum start-up current. If no other influencing factors are present (peak loads), the value for motor startup **I MOTOR START** set at address 1107 may be an average value:

Based on the Long-Term Current Rating:

$$\frac{135 \text{ A}}{200 \text{ A}} \cdot I_{\text{Nom CT sec}} = 0.68 \text{ A}$$

$$I_{\text{STARTUP sec}} = \frac{2.5 \text{ A} + 0.68 \text{ A}}{2} \approx 1.6 \text{ A}$$

For ratios deviating from nominal conditions, the motor tripping time changes:

$$t_{\text{TRIP}} = \left(\frac{I_{\text{STARTUP}}}{I} \right)^2 \cdot T_{\text{Max.STARTUP}}$$

At 80% of nominal voltage (which corresponds to 80% of nominal starting current), the tripping time is:

$$t_{\text{TRIP}} = \left(\frac{624 \text{ A}}{0.8 \cdot 624 \text{ A}} \right)^2 \cdot 8.5 \text{ s} = 13.3 \text{ s}$$

After the time delay (4104 **LOCK ROTOR TIME**) has elapsed, the binary input becomes effective and generates a trip signal. If the locked rotor time is set just long enough that during normal startup the binary input „>Rot or Locked“ (FNo. 6805) is reliably reset during the delay time **LOCK ROTOR TIME**, faster tripping will be available during motor starting under locked rotor conditions.

2.6.2 Motor Restart Inhibit 66

The motor restart inhibit prevents restarting of the motor when this restart may cause the permissible thermal limits of the rotor to be exceeded.

Additionally, the function can trip directly if the rotor temperature exceeds the maximum admissible temperature (100%) (rotor overload).

2.6.2.1 Description

General

The rotor temperature of a motor generally remains well below its maximum admissible temperature during normal operation and also under increased load conditions. However, high startup currents required during motor startup increase the risk of the rotor being thermally damaged rather the stator, due to the short thermal constant of the rotor. To avoid that multiple starting attempts provoke tripping, a restart of the motor must be inhibited if it is apparent that the thermal limit of the rotor will be exceeded during this startup attempt. Therefore, the 7SJ61 relays feature the motor restart inhibit which outputs a blocking command until a new motor startup is permitted for the deactivated motor (restarting limit). The blocking signal must be configured to a binary output relay of the device whose contact is inserted in the motor starting circuit.

Determining the Rotor Overtemperature

Since the rotor current cannot be measured directly, the stator current must be used to generate a thermal replica of the rotor. The r.m.s. values of the currents are used for this. The rotor overtemperature Θ_R is calculated using the largest of these three phase currents. It is assumed that the thermal limit values for the rotor winding are based on the manufacturer's data regarding the nominal starting current, maximum permissible starting time, and the number of starts permitted from cold (n_{cold}) and warm (n_{warm}) conditions. From this data, the device performs the necessary calculations to establish the thermal replica of the rotor and issues a blocking signal until the thermal replica of the rotor decreases below the restarting limit at which startup is permitted again.

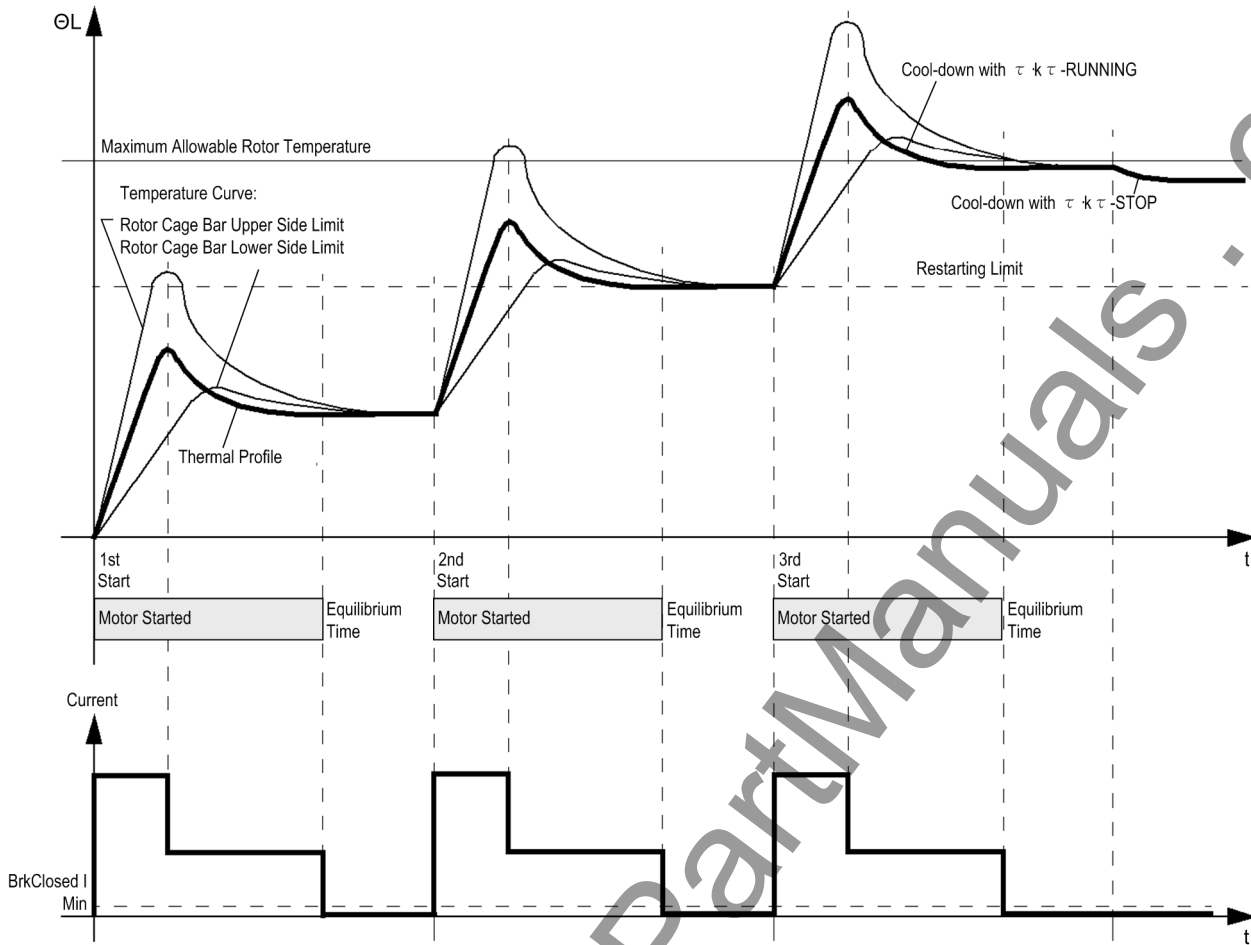

Figure 2-32 Temperature curve at the rotor and in the thermal replica during repeated start-up attempts

Although the heat distribution on the rotor bars may severely differ during motor starting, the different maximum temperatures in the the rotor are not pertinent for motor restart inhibit (see Figure 2-32). It is much more important to establish a thermal replica, after a complete motor start, that is appropriate for the protection of the motor's thermal condition. Figure 2-32 shows, as an example, the heating processes during repeated motor starts (three starts from cold operating condition), as well as the thermal replica in the protection relay.

Restart Threshold

If the rotor temperature has exceeded the restart threshold, the motor cannot be restarted. The blocking signal is not lifted unless the rotor temperature has fallen below the restarting limit, that is, when exactly one start becomes possible without exceeding the excessive rotor temperature limit. Based on the specified motor parameters the device calculates the normalized restarting limit Θ_{Restart} :

$$\Theta_{\text{Restart}} = \left(\frac{I_{\text{STARTUP}}}{I_{\text{MOTNom}} \cdot k_R} \right)^2 \cdot \left(1 - e^{-\frac{(n_{\text{cold}} - 1) \cdot T_{\text{start max}}}{\tau_R}} \right)$$

Where:

Θ_{Restart}	=	Temperature threshold below which restarting is possible
k_R	=	k-factor for the rotor, calculated internally
I_{STARTUP}	=	Startup current
I_{MOTNom}	=	Nominal motor current
$T_{\text{start max}}$	=	Maximum startup time
τ_R	=	Thermal time constant of the rotor, calculated internally
n_{cold}	=	Permissible number of startups in cold condition

The restarting limit Θ_{Restart} is displayed as operational measured value in the "thermal measured values".

Rotor Overload Detection

If the rotor temperature exceeds 100% of the maximum temperature calculated from the thermal rotor profile, there is a risk of motor damage. If this threshold value is exceeded, either tripping occurs or an overload message is issued. The desired reaction can be determined via parameter 4311 **ROTOR OVERLOAD**. If parameter is set to **OFF**, rotor overload will not be detected.

Restart Time

The motor manufacturer allows a maximum number of cold (n_{cold}) and warm (n_{warm}) startup attempts. Thereafter, another startup is not permitted. A certain time must have passed — restarting time T_{Restart} — to ensure that the rotor has cooled off (operational measured value 661).

Equilibrium Time

This thermal behavior is provided for in the protection as follows: Each time the motor is shut down, the timer starts (address 4304 **T Equal**). It takes into account the different thermal conditions of the motor parts at the moment of shutdown. During the equilibrium time, the thermal replica of the rotor is not updated. It is maintained constant to replicate the equilization process in the rotor. Then, the thermal replica with the corresponding time constant (rotor time constant x extension factor) cools down. During the equilibrium time the motor cannot be restarted. As soon as the temperature sinks below the restarting limit, the next restart attempt can be made.

Minimum Inhibit Time

Regardless of thermal replicas, some motor manufacturers require a minimum inhibit time after the maximum number of permissible startup attempts has been exceeded.

The total duration of the inhibit signal depends on which of the times $T_{\text{Min Inhibit}}$ or T_{Restart} is longer.

Total Time $T_{Reclose}$

The total waiting time $T_{Reclose}$ before the motor can be restarted is therefore composed of the equilibrium time, the time $T_{Restart}$ calculated from the thermal replica and the value that is needed to drop below the limit for re-starting. If the calculated temperature rise of the rotor is above the restarting limit when the motor is shut down, the minimum inhibit time will be started together with the equilibrium time.

Thus the total inhibit time $T_{Reclose}$ can become equal to the minimum inhibit time if it is longer than the sum of the two first mentioned times:

$$T_{Reclose} = T_{Equal} + T_{Restart} \quad \text{for } T_{Min\ Inhibit} < T_{Equal} + T_{Restart}$$

$$T_{Reclose} = T_{Min\ Inhibit} \quad \text{for } T_{Min\ Inhibit} \geq T_{Equal} + T_{Restart} \text{ if the calculated excessive temperature} > \text{re-starting limit}$$

The operational measured value $809 T_{Reclose}$ (visible in the thermal measured values) is the remaining time until the next restart is permissible. When the rotor excessive temperature is below the restarting limit and thus the next restarting attempt is permitted, the operational measured value for the waiting time has reached zero.

Extension of Cool Down Time Constants

In order to properly account for the reduced heat exchange when a self-ventilated motor is stopped, the cool down time constants can be increased relative to the time constants for a running machine with the factor **K τ at STOP** (address 4308). The criterion for the motor stop is the undershooting of a set current threshold **BkrClosed I MIN**. This understands that the motor idle current is greater than this threshold. The pickup threshold **BkrClosed I MIN** affects also the thermal overload protective function (see Section 2.7).

While the motor is running, the heating of the thermal replica is modeled with the time constant τ_R calculated from the motor ratings, and the cool down calculated with the time constant $\tau_R \cdot \mathbf{K\tau\ at\ RUNNING}$ (address 4309). In this way, the protection caters to the requirements in case of a slow cool down (slow temperature equilibrium).

For calculation of the restarting time $T_{Restart}$ the following applies:

$$T_{RESTART} = k_{\tau\ at\ STOP} \cdot \tau_R \cdot I_{Nom} \left[\frac{\Theta_{pre} \cdot n_{cold}}{n_{cold} - 1} \right] \quad \text{at Stop}$$

$$T_{RESTART} = k_{\tau\ at\ RUNNING} \cdot \tau_R \cdot I_{Nom} \left[\frac{\Theta_{pre} \cdot n_{cold}}{n_{cold} - 1} \right] \quad \text{at Running}$$

with

- $k_{\tau\ at\ STOP}$ Extension factor for the time constant = **K τ at STOP**, address 4308
- $k_{\tau\ at\ RUNNING}$ Extension factor for the time constant = **K τ at RUNNING**, address 4309
- Θ_{pre} thermal replica at the moment of motor shutdown (depending on operational condition)
- τ_R Rotor time constant, calculated internally

Behavior in Case of Power Supply Failure

Depending on the setting in address 235 **ATEX100** of Power System Data 1 (see Section 2.1.3.2) the value of the thermal replica is either reset to zero (**ATEX100 = NO**) if the power supply voltage fails, or cyclically buffered in a non-volatile memory (**ATEX100 = YES**) so that it is maintained in the event of auxiliary supply voltage failure. In the latter case, when power supply is restored, the thermal replica uses the stored value for calculation and matches it to the operating conditions. The first option is the default setting. For further details, see /5/.

Emergency Start

If, for emergency reasons, motor starting that will exceed the maximum allowable rotor temperature must take place, the motor restart inhibit signal can be removed via a binary input („>66 emer. start“), thus allowing a new starting attempt. The thermal rotor profile, however, continues to function and the maximum allowable rotor temperature will be exceeded. No motor shutdown will be initiated by the motor restart inhibit, but the calculated excessive temperature of the rotor can be observed for risk assessment.

Blocking

If the motor restart inhibit function is blocked via binary input „>BLOCK 66“ or switched off, the thermal replica of the rotor overtemperature, the equilibrium time **T Equal** and the minimum inhibit time **T MIN. INHIBIT** are reset. Thus any blocking signal that is present or upcoming is disregarded.

Via another binary input („>66 RM th.rep1.“) the thermal replica can be reset independently. This may be useful for testing and commissioning, and after a power supply voltage failure.

Logic

There is no pickup annunciation for the restart inhibit and no trip log is produced. The following figure shows the logic diagram for the restart inhibit.

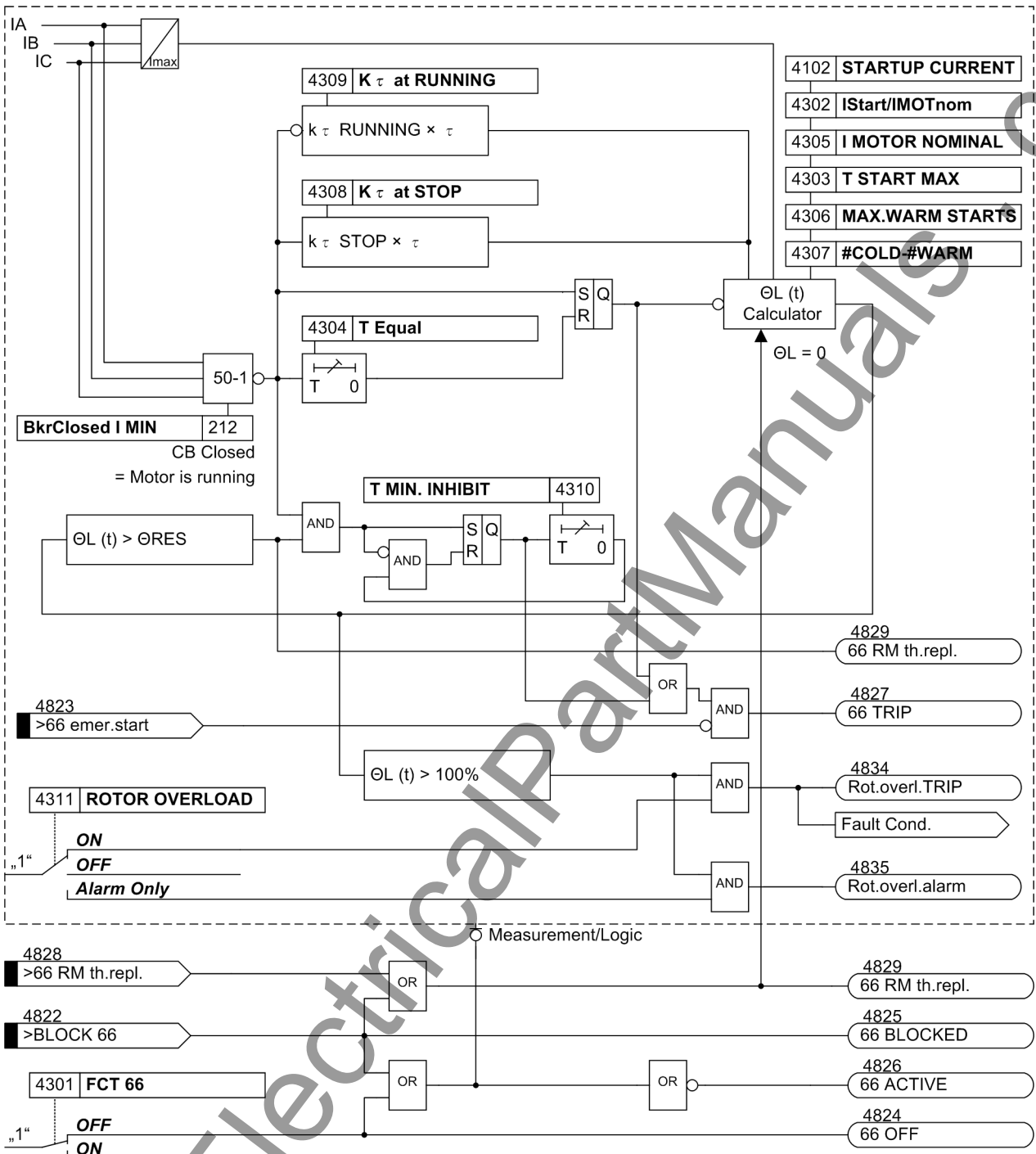

Figure 2-33 Logic diagram for the restart inhibit

2.6.2.2 Setting Notes

General

Restart inhibit is only effective and accessible if address 143 **48** is set to **Enabled**. If not required, this function is set to **Disabled**. The function can be turned **ON** or **OFF** under address 4301 **FCT 66**..



Note

When function settings of the motor restart inhibit are changed, the thermal replica of this function is reset.

The motor restart inhibit acts on the starting process of a motor that is shut down. A motor is considered shut down when its current consumption falls below the settable threshold 212 **BkrClosed I MIN**. Therefore, this threshold must be set lower than the motor idle current.

The motor restart inhibit concludes the condition „warm motor“ from the thermal replica of the restart inhibit. For this function, address 4301 **FCT 66** has to be enabled.

Additionally, the function can trip directly if the rotor temperature exceeds the maximum admissible temperature (100%). For this purpose address 4311 **ROTOR OVERLOAD** is set to **ON**. If only monitoring is desired, set to **Alarm Only**, otherwise to **OFF**.

Characteristic Values

Many of the variables needed to calculate the rotor temperature are supplied by the motor manufacturer. Among these variables are the starting current $I_{STARTUP}$, the nominal motor current $I_{MOT. NOM}$, the maximum allowable starting time **T START MAX** (address 4303), the number of allowable starts from cold conditions (n_{cold}), and the number of allowable starts from warm conditions (n_{warm}).

The starting current is entered at address 4302 **IStart/IMOTnom**, expressed as a multiple of nominal motor current. In contrast, the nominal motor current is entered as a secondary value, directly in amperes, at address 4305 **I MOTOR NOMINAL**. The number of warm starts allowed is entered at address 4306 (**MAX.WARM STARTS**) and the difference (**#COLD-#WARM**) between the number of allowable cold and warm starts is entered at address 4307.

For motors without separate ventilation, the reduced cooling at motor stop can be accounted for by entering the factor **K τ at STOP** at address 4308. As soon as the current no longer exceeds the setting value entered at address 212 **BkrClosed I MIN**, motor standstill is detected and the time constant is increased by the extension factor configured.

If no difference between the time constants is to be used (e.g. externally-ventilated motors), then the extension factor **K τ at STOP** should be set to 1.

The cooling with the motor running is influenced by the extension factor 4309 **K τ at RUNNING**. This factor considers that motor running under load and a stopped motor do not cool down at the same speed. It becomes effective as soon as the current exceeds the value set at address 212 **BkrClosed I MIN**. With **K τ at RUNNING** = 1 the heating and the cooling time constant are the same at operating conditions ($I > \text{BkrClosed I MIN}$).

Example: Motor with the following data:

Rated Voltage	$V_{\text{Nom}} = 6600 \text{ V}$
Nominal current	$I_{\text{Nom}} = 126 \text{ A}$
Startup current	$I_{\text{STARTUP}} = 624 \text{ A}$
Startup duration	$T_{\text{Start max.}} = 8.5 \text{ s}$
Permitted starts with cold motor	$n_{\text{cold}} = 3$
Permitted starts with warm motor	$n_{\text{warm}} = 2$
Current transformer	200 A / 1 A

The following settings are derived from these data:

$$I_{\text{STARTUP}} / I_{\text{MOTNom}} = \frac{624 \text{ A}}{126 \text{ A}} = 4.95$$

$$I_{\text{MOTNom}} = \frac{126 \text{ A}}{200 \text{ A}} = 0.62 \cdot I_{\text{NomCTsec}}$$

The following settings are made:

IStart / IMOTnom = 4.9

I MOTOR NOMINAL = 0.6 A

T START MAX = 8.5 s

MAX.WARM STARTS = 2

#COLD-#WARM = 1

For the rotor temperature equilibrium time, (address 4304) a setting time of approx. **T Equal** = 1 min has proven to be a good value. The value for the minimum inhibit time **T MIN. INHIBIT** depends on the motor manufacturer, or by the user's requirements. It must in any case be higher than 4304 **T Equal**. In this example, a value has been chosen that reflects the thermal replica (**T MIN. INHIBIT** = 6.0 min).

The motor manufacturer's, or the requirements also determine also the extension factor for the time constant during cool-down, especially with the motor stopped. Where no other specifications are made, the following settings are recommended: **K_τ at STOP = 5** and **K_τ at RUNNING = 2**.

For a proper functioning, it is also important that the CT values and the current threshold for distinction between stopped and running motor (address 212 **BkrClosed I MIN**, recommended setting $\approx 0.1 I_{\text{MOT.NOM}}$) have been set correctly. An overview of parameters and their default settings is generally given in the setting tables.

Temperature Behavior during Changing Operating States

For a better understanding of the above considerations several possible operating ranges in two different operating areas will be discussed in the following paragraph. Settings indicated above are to be used prevailing 3 cold and 2 warm startup attempts have resulted in the restart limit reaching 66.7%.

A) Below the thermal restarting limit:

1. A normal startup brings the machine into a temperature range below the thermal restarting limit and the machine is stopped. The stop launches the equilibrium time $4304 T_{Equal}$ and generates the message „66 TRIP“. The equilibrium time expires and the message „66 TRIP“ is cleared. During the time T_{Equal} the thermal replica remains "frozen" (see Figure 2-34, on the left).
2. A normal startup brings the machine into a temperature range below the thermal restarting limit, the machine is stopped and is started by an emergency startup without waiting for the equilibrium time to expire. The equilibrium time is reset, the thermal replica is released and „66 TRIP“ is reported as going (see Figure 2-34, to the right).

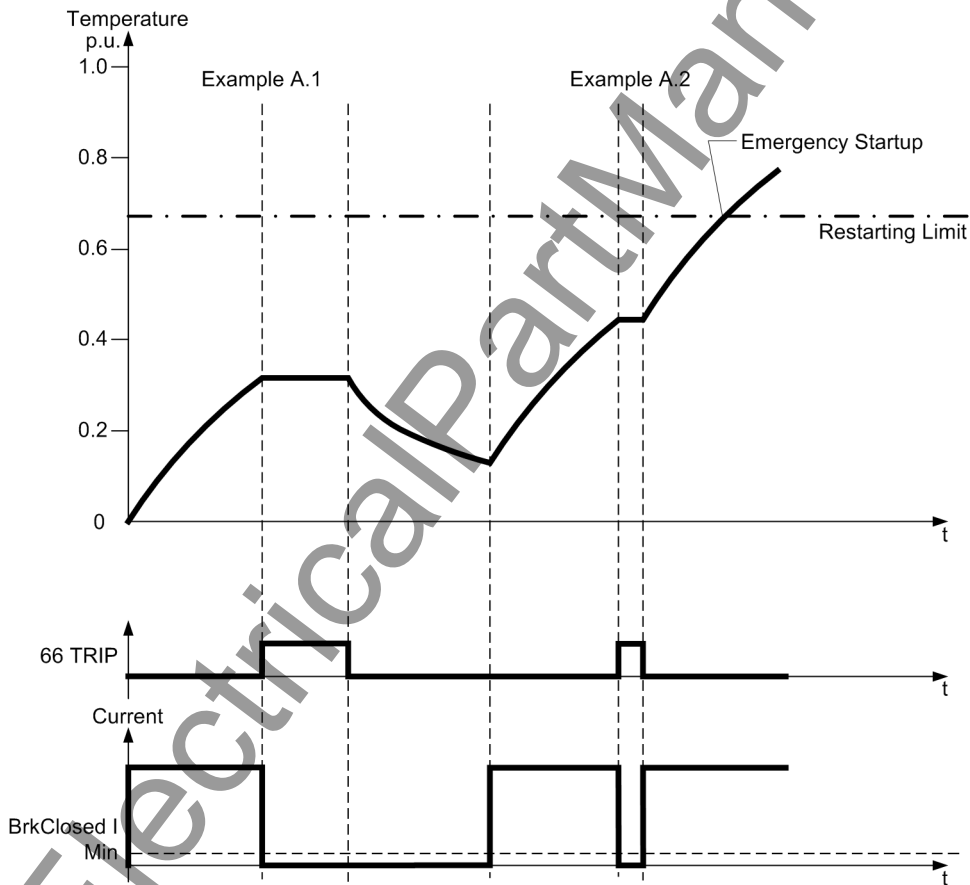

Figure 2-34 Startups according to examples A.1 and A.2

B) Above the thermal restarting limit:

1. A startup brings the machine from load operation into a temperature range far above the thermal restarting limit and the machine is stopped. The minimum inhibit time and the equilibrium time are started and „66 TRIP“ is reported. The temperature cool-down below the restarting limit takes longer than 4310 and **T MIN. INHIBIT** and 4304 **T Equal**, so that the time passing until the temperature falls below the temperature limit is the decisive factor for clearing the message „66 TRIP“. The thermal replica remains "frozen" while the equilibrium time expires (see Figure 2-35, to the left).
2. A startup brings the machine from load operation into a temperature range just above the thermal restarting limit and the machine is stopped. The minimum inhibit time and the equilibrium time are started and „66 TRIP“ is reported. Although the temperature soon falls below the restarting limit, the blocking „66 TRIP“ is preserved until the equilibrium time and the minimum inhibit time have expired (see Figure 2-35, to the right).

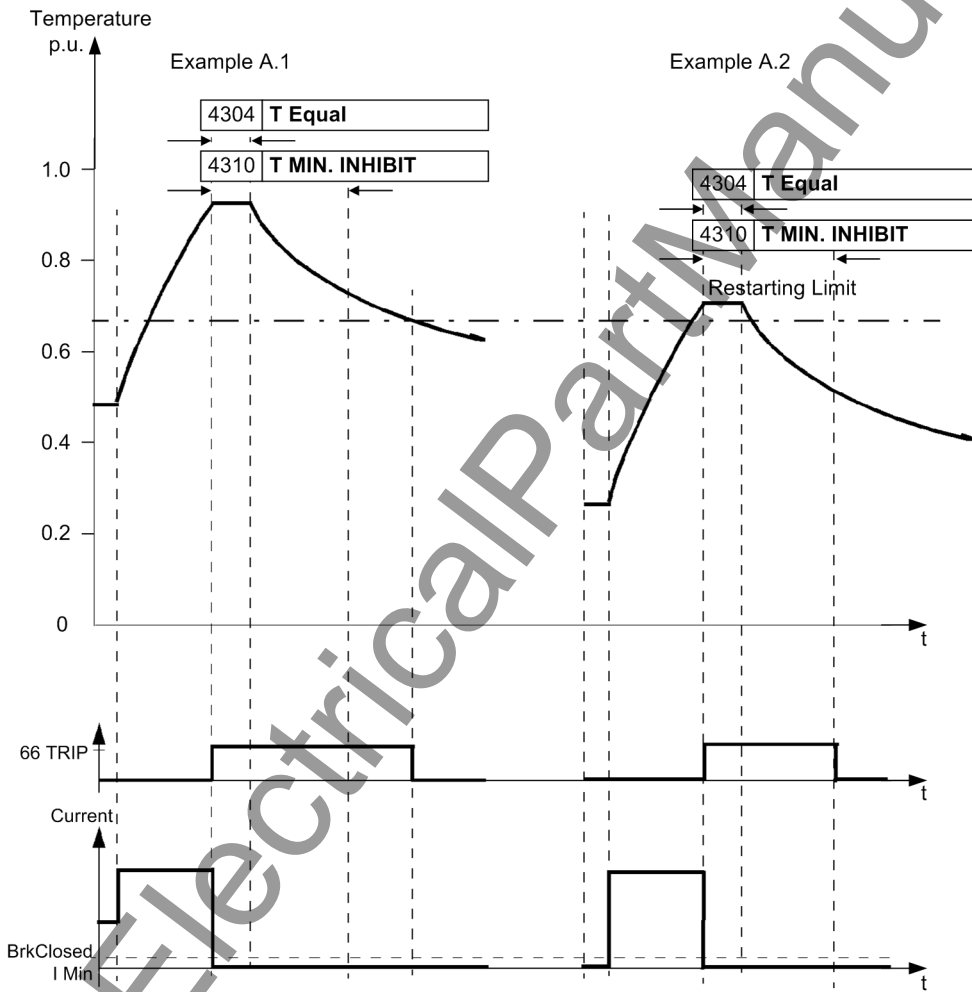

Figure 2-35 Starting up according to examples B.1 and B.2

2.6.3 Load Jam Protection

The load jam protection serves to protect the motor during sudden rotor blocking. Damage to drives, bearings and other mechanic motor components can be avoided or reduced by means of quick motor shutdown.

The blocking results in a current jump in the phases. This is detected by the function as a recognition criteria.

The thermal overload protection would of course also pickup as soon as the configured threshold values of the thermal replicas are exceeded. The load jam protection, however, is able to detect a locked rotor quicker, thus reducing possible damage to the motor and powered equipment.

2.6.3.1 Mode of Operation

Principle of Operation

Figure 2-36 illustrates the feature of an asynchronous cage motor. Nominal current is flowing at normal load. If the load is increased, the current flow also increases and the speed decreases. Above a certain load, however, the motor is no longer able to adjust the speed by increasing the torque. The motor comes to standstill in spite of an increase in current to a multiple of its nominal value (see Figure 2-37). Other types of induction motors have similar characteristics. Apart from the thermal heating of the motor, a locked rotor causes substantial mechanical strain on coils and bearings.

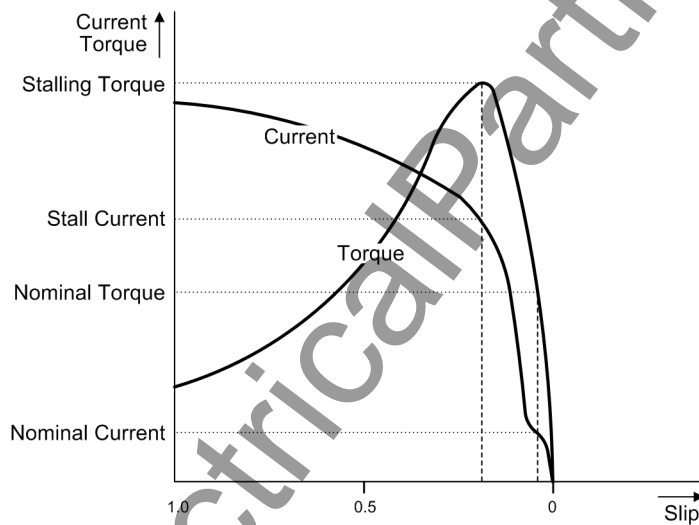

Figure 2-36 Typical characteristic of an asynchronous cage motor

Figure 2-37 illustrates an example of a locked rotor caused by mechanical overload. It should be noted that the current flow increases substantially as soon as the mechanical load reaches the stability limit.

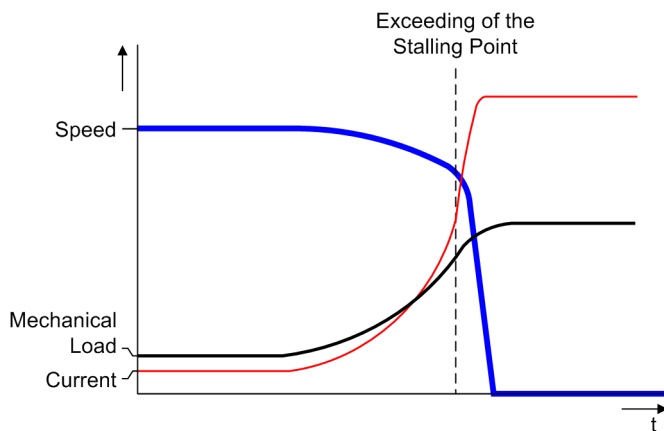

Figure 2-37 Example of the time characteristic for mechanical rotor blocking

Logic

A continuous comparison of the motor current with the configured threshold values of the protection function takes place for the purpose of detecting a locked rotor. Figure 2-38 shows the logic diagram. The threshold-value comparison is blocked during the motor startup phase, as the startup currents usually move in a size similar to the occurring currents when a rotor is locked.

The algorithm verifies the motor standstill according to currents and (if available) the message „>52 - a“. As soon as a current increase is applied after detection of the motor standstill, the load jam protection is temporarily blocked in order to avoid motor shutdown during the motor startup phase.

The motor is detected as being in standstill when none of the three phase currents exceeds the threshold set via address 212 **BkrClosed I MIN** and the binary signal „>52 - a“ is inactive. The „>52 - a“ signal is only taken into account if the binary input is allocated accordingly.

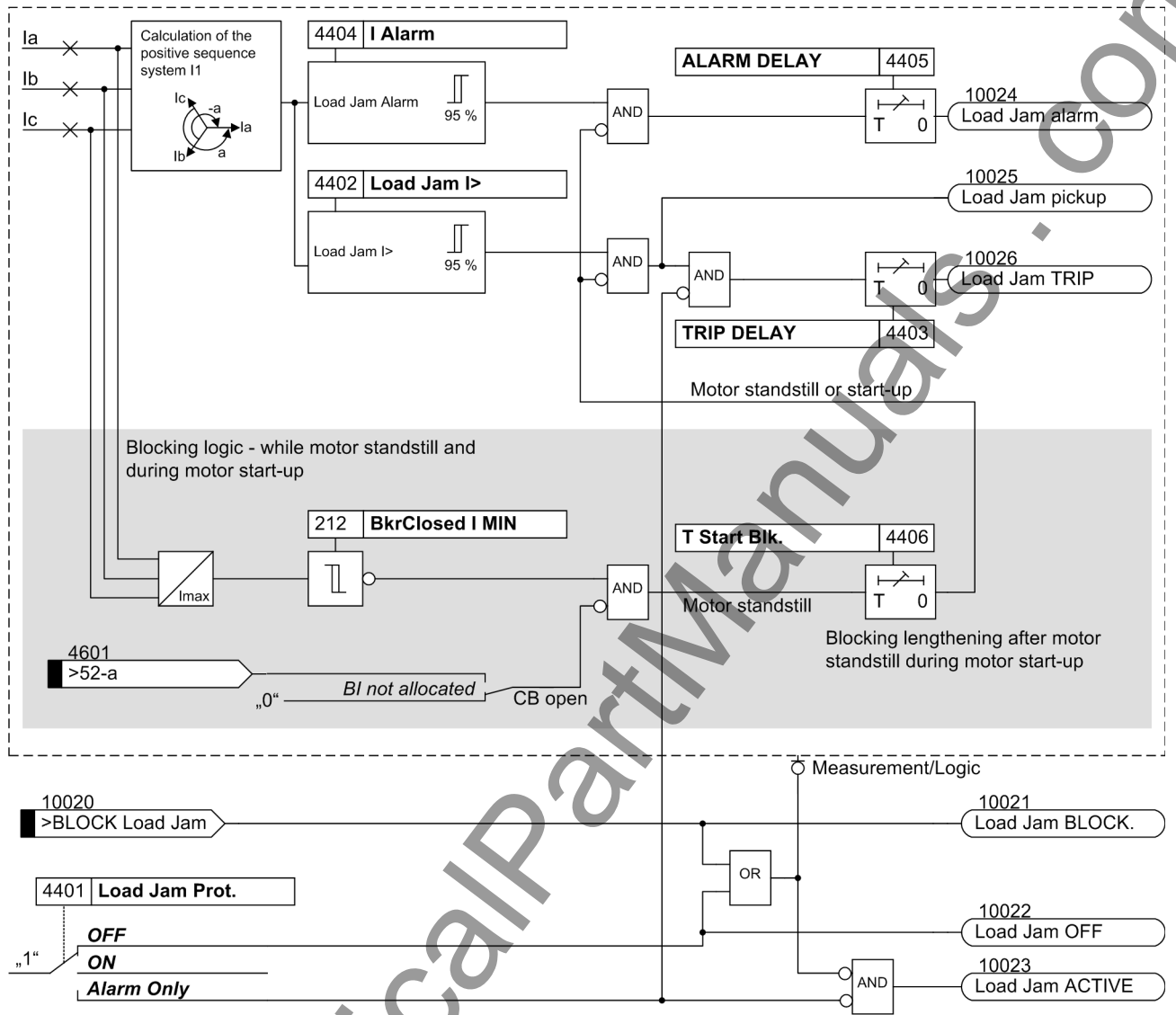

Figure 2-38 Logic diagram of the load jam protection

2.6.3.2 Setting Notes

Elements

A warning and a tripping element can be configured. The threshold value of the tripping element 4402 **Load Jam I** is usually configured below motor startup at double motor ampere rating. Warning element 4404 **I Alarm** is naturally set below the tripping element, to approx. 75% of the tripping element, with a longer delay time (parameter 4405 **ALARM DELAY**). If the warning element is not required, the pickup value can be set to its maximum value and the respective message from the buffers can be removed.

Motor Standstill and Motor Startup

Due to the threshold setting below the motor startup current, the load jam protection during motor startup must be blocked. Via parameters 212 **BkrClosed I MIN** the open circuit breaker is detected during current-flow measurement (motor standstill). In this condition the load change protection is blocked. After having closed the circuit breaker, the blocking is maintained during motor startup by the setting 4406 **T Start Blk.**. In order to avoid malfunctioning, the **T Start Blk.** is set to the double startup time.

Motor Protection Example

Figure 2-39 illustrates an example of a complete motor protection characteristic. Such characteristic usually consists of different protection elements, and each element is responsible for special motor malfunctions. These are:

- Thermal overload protection: to avoid overheating of the motor due to inadmissible load
- Load jam protection: to prevent overheating and mechanical damage due to a locked rotor
- Motor starting protection: protects the motor against prolonged startup procedures and the consequent thermal overload of the rotor
- Overcurrent and high-current elements: for motor shutdown due to electrical faults

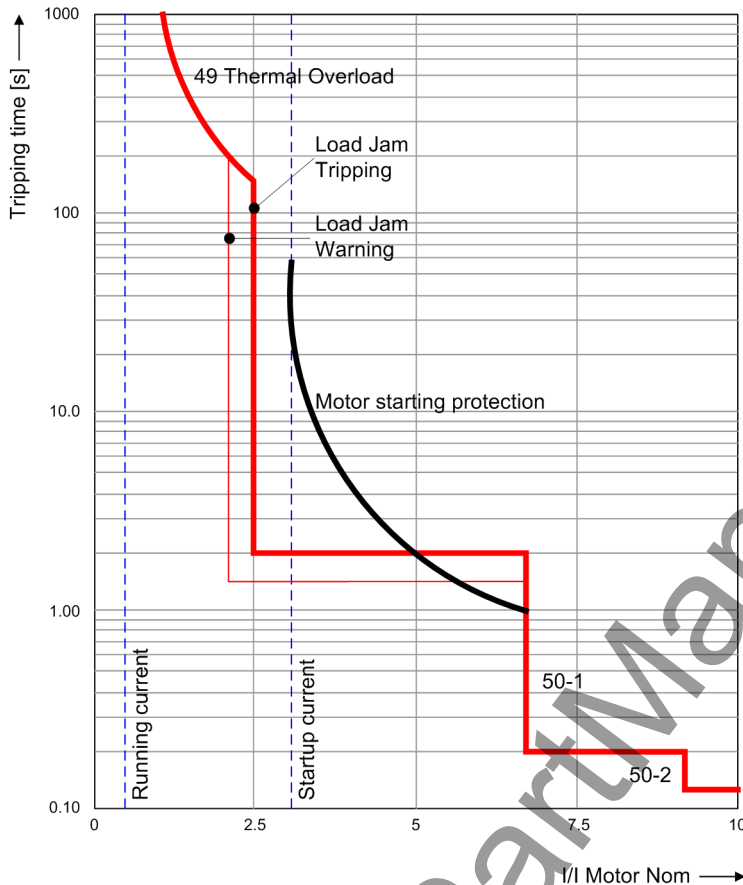

Figure 2-39 Example of a complete motor protection characteristic

Example:

Motor with the following data:

Nominal voltage	$V_{Nom} = 6600 \text{ V}$
Nominal current	$I_{Nom} = 126 \text{ A}$
Long-term current rating	$I_{max} = 135 \text{ A}$
Startup duration	$T_{startmax.} = 8.5 \text{ s}$
Current transformer	$I_{NomCTprim} / I_{NomCTsec} = 200 \text{ A} / 1 \text{ A}$

The setting for address 4402 **Load Jam I** as secondary value is calculated as follows:

$$\frac{2 \cdot I_{Nom}}{I_{NomCTprim}} \cdot I_{NomCTsec} = \frac{2 \cdot 126}{200} = 1.26 \text{ A}$$

The tripping delay time can remain at the default setting of 1 s. The warning threshold is set to 75% of the tripping element (4404 **I Alarm** = 0.95 A sec.).

The tripping delay time can remain at the default setting of 2 s.

In order to block the function during motor startup, the parameter 4406 **T Start Blk.** is set to double startup time (**T Start Blk.** = 2 · 8.5 s = 17 s).

2.6.4 Motorprotection (Motor Starting Protection 48, Motor Restart Inhibit 66, LoadJam)

2.6.4.1 Settings

The table indicates region-specific default settings. Column C (configuration) indicates the corresponding secondary nominal current of the current transformer.

Addr.	Parameter	C	Setting Options	Default Setting	Comments
4101	FCT 48/66		OFF ON	OFF	48 / 66 Motor (Startup Monitor/Counter)
4102	STARTUP CURRENT	1A	0.50 .. 16.00 A	5.00 A	Startup Current
		5A	2.50 .. 80.00 A	25.00 A	
4103	STARTUP TIME		1.0 .. 180.0 sec	10.0 sec	Startup Time
4104	LOCK ROTOR TIME		0.5 .. 180.0 sec; ∞	2.0 sec	Permissible Locked Rotor Time
4105	STARTUP T WARM		0.5 .. 180.0 sec; ∞	10.0 sec	Startup Time for warm motor
4106	TEMP.COLD MOTOR		0 .. 80 %; ∞	25 %	Temperature limit for cold motor
4301	FCT 66		OFF ON	OFF	66 Startup Counter for Motors
4302	IStart/IMOTnom		1.10 .. 10.00	4.90	I Start / I Motor nominal
4303	T START MAX		1 .. 320 sec	10 sec	Maximum Permissible Starting Time
4304	T Equal		0.0 .. 320.0 min	1.0 min	Temperature Equalization Time
4305	I MOTOR NOMINAL	1A	0.20 .. 1.20 A	1.00 A	Rated Motor Current
		5A	1.00 .. 6.00 A	5.00 A	
4306	MAX.WARM STARTS		1 .. 4	2	Maximum Number of Warm Starts
4307	#COLD-#WARM		1.. 2	1	Number of Cold Starts - Warm Starts
4308	K _τ at STOP		0.2 .. 100.0	5.0	Extension of Time Constant at Stop
4309	K _τ at RUNNING		0.2 .. 100.0	2.0	Extension of Time Constant at Running
4310	T MIN. INHIBIT		0.2 .. 120.0 min	6.0 min	Minimum Restart Inhibit Time
4311	ROTOR OVERLOAD		ON OFF Alarm Only	ON	Rotor Overload Protection
4401	Load Jam Prot.		OFF ON Alarm Only	OFF	Load Jam Protection

Addr.	Parameter	C	Setting Options	Default Setting	Comments
4402	Load Jam I>	1A	0.50 .. 12.00 A	2.00 A	Load Jam Tripping Threshold
		5A	2.50 .. 60.00 A	10.00 A	
4403	TRIP DELAY		0.00 .. 600.00 sec	1.00 sec	Load Jam Trip Delay
4404	I Alarm	1A	0.50 .. 12.00 A	1.80 A	Load Jam Alarm Threshold
		5A	2.50 .. 60.00 A	9.00 A	
4405	ALARM DELAY		0.00 .. 600.00 sec	1.00 sec	Load Jam Alarm Delay
4406	T Start Blk.		0.00 .. 600.00 sec	10.00 sec	Load Jam Blocking after motor start

2.6.4.2 Information List

No.	Information	Type of Information	Comments
4822	>BLOCK 66	SP	>BLOCK Motor Startup counter
4823	>66 emer.start	SP	>Emergency start
4824	66 OFF	OUT	66 Motor start protection OFF
4825	66 BLOCKED	OUT	66 Motor start protection BLOCKED
4826	66 ACTIVE	OUT	66 Motor start protection ACTIVE
4827	66 TRIP	OUT	66 Motor start protection TRIP
4828	>66 RM th.repl.	SP	>66 Reset thermal memory
4829	66 RM th.repl.	OUT	66 Reset thermal memory
4834	66 OVERL. TRIP	OUT	66 Rotor overload TRIP
4835	66 OVERL.ALARM	OUT	66 Rotor Overload Alarm
6801	>BLK START-SUP	SP	>BLOCK Startup Supervision
6805	>Rotor locked	SP	>Rotor locked
6811	START-SUP OFF	OUT	Startup supervision OFF
6812	START-SUP BLK	OUT	Startup supervision is BLOCKED
6813	START-SUP ACT	OUT	Startup supervision is ACTIVE
6821	START-SUP TRIP	OUT	Startup supervision TRIP
6822	Rotor locked	OUT	Rotor locked
6823	START-SUP pu	OUT	Startup supervision Pickup
10020	>BLOCK Jam Prot	SP	>BLOCK Load Jam Protection
10021	JAM PROT.BLOCK.	OUT	Load Jam Protection is BLOCKED
10022	JAM PROT.OFF	OUT	Load Jam Protection is OFF
10023	JAM PROT.ACTIVE	OUT	Load Jam Protection is ACTIVE
10024	Load Jam alarm	OUT	Load Jam Protection alarm
10025	Load Jam pickup	OUT	Load Jam Protection picked up
10026	Load Jam TRIP	OUT	Load Jam Protection TRIP

2.7 Thermal Overload Protection 49

The thermal overload protection is designed to prevent thermal overloads from damaging the protected equipment. The protection function represents a thermal replica of the equipment to be protected (overload protection with memory capability). Both the previous history of an overload and the heat loss to the environment are taken into account.

Applications

- In particular, the thermal overload protection allows the thermal status of motors, generators and transformers to be monitored.
- If an additional thermal input is available, the thermal replica may take the actual ambient or coolant temperature into account.

2.7.1 Description

Thermal Replica

The device calculates the overtemperature in accordance with a single-body thermal replica, based on the following differential equation:

$$\frac{d\Theta}{dt} + \frac{1}{\tau_{th}} \cdot \Theta = \frac{1}{\tau_{th}} \cdot \left(\left(\frac{I}{k \cdot I_{Nom\ Obj.}} \right)^2 + \Theta_u' \right)$$

with

Θ	Present overtemperature related to the final overtemperature at maximum allowed phase current $k \cdot I_{Nom\ Obj.}$
τ_{th}	Thermal time constant of the protected object's heating
I	Present true r.m.s value of phase current
k	k -factor indicating the maximum permissible constant phase current referred to the nominal current of the protected object
$I_{Nom\ Obj.}$	Nominal current of protected object

$$\Theta_u' = \frac{\Theta_u - 40^\circ\text{C}}{k^2 \cdot \Theta_{Nom}}$$

with

Θ_u	Measured ambient temperature or coolant temperature
Θ_{Nom}	Temperature at object nominal current

If the ambient or coolant temperature is not measured, a constant value of $\Theta_u = 40^\circ\text{C}$ is assumed so that $\Theta_u' = 0$.

The protection feature therefore represents a thermal replica of the equipment to be protected (overload protection with memory capability). Both the previous history of an overload and the heat loss to the environment are taken into account.

When the calculated overtemperature reaches the first settable threshold **49** \ominus **ALARM**, an alarm annunciation is issued, e.g. to allow time for the load reduction measures to take place. When the calculated overtemperature reaches the second threshold, the protected equipment may be disconnected from the system. The highest overtemperature calculated from the three phase currents is used as the criterion.

The maximum thermally-permissible continuous current I_{\max} is described as a multiple of the object nominal current $I_{\text{Nom Obj.}}$:

$$I_{\max} = k \cdot I_{\text{Nom Obj.}}$$

In addition to the k factor (parameter **49 K-FACTOR**), the **TIME CONSTANT** τ_{th} and the alarm temperature **49** \ominus **ALARM** (in percent of the trip temperature Θ_{TRIP}) must be specified.

Overload protection also features a current warning element (**I ALARM**) in addition to the temperature warning element. The current warning element may report an overload current prematurely, even if the calculated operating temperature has not yet attained the warning or tripping levels.

Coolant Temperature (Ambient Temperature)

The device can account for external temperatures. Depending on the type of application, this may be a coolant or ambient temperature. The temperature can be measured via a temperature detection unit (RTD-box). For this purpose, the required temperature detector is connected to detector input 1 of the first RTD-box (corresponds to RTD 1). If incorrect temperature values are measured or there are disturbances between the RTD-box and the device, an alarm will be issued and the standard temperature of $\Theta_u = 40^\circ\text{C}$ is used for calculation with the ambient temperature detection simply being ignored.

When detecting the coolant temperature, the maximum permissible current I_{\max} is influenced by the temperature difference of the coolant (in comparison with the standard value = 104°F or 40°C). If the ambient or coolant temperature is low, the protected object can support a higher current than it does when the temperature is high.

Extension of Time Constants

When using the device to protect motors, the varying thermal response at standstill or during rotation may be correctly evaluated. When running down or at standstill, a motor without external cooling loses heat more slowly, and a longer thermal time constant must be used for calculation. For a motor that is switched off, the 7SJ61 increases the time constant τ_{th} by a programmable factor (k_τ factor). The motor is considered to be off when the motor currents drop below a programmable minimum current setting **BkrClosed I MIN** (refer to "Current Flow Monitoring" in Section 2.1.3). For externally-cooled motors, cables and transformers, the **K τ -FACTOR = 1**.

Current Limiting

In order to ensure that overload protection, on occurrence of high fault currents (and with small time constants), does not result in extremely short tripping times thereby perhaps affecting time grading of the short circuit protection, the thermal replica is frozen (kept constant) as soon as the current exceeds the threshold value **1107 I MOTOR START**.

Blocking

The thermal memory may be reset via a binary input („>RES 49 Image“) and the current-related overtemperature value is thus reset to zero. The same is accomplished via the binary input („>BLOCK 49 O/L“); in this case the entire overload protection is blocked completely, including the current warning element.

When motors must be started for emergency reasons, temperatures above the maximum permissible overtemperatures can be allowed by blocking the tripping signal via a binary input („>EmergencyStart“). Since the thermal replica may have exceeded the tripping temperature after initiation and dropout of the binary input has taken place, the protection function features a programmable run-on time interval (**T EMERGENCY**) which is started when the binary input drops out and continues suppressing a trip signal. Tripping via the overload protection is suppressed until this time interval has elapsed. The binary input affects only the trip command. There is no effect on the trip log nor does the thermal replica reset.

Behavior in Case of Power Supply Failure

Depending on the setting in address 235 **ATEX100** of Power System Data 1 (see Section 2.1.3) the value of the thermal replica is either reset to zero (**ATEX100 = NO**) if the power supply voltage fails, or cyclically buffered in a non-volatile memory (**ATEX100 = YES**) so that it is maintained in the event of auxiliary supply voltage failure. In the latter case, the thermal replica uses the stored value for calculation and matches it to the operating conditions. The first option is the default setting (see /5).

The following figure shows the logic diagram for the overload protection function.

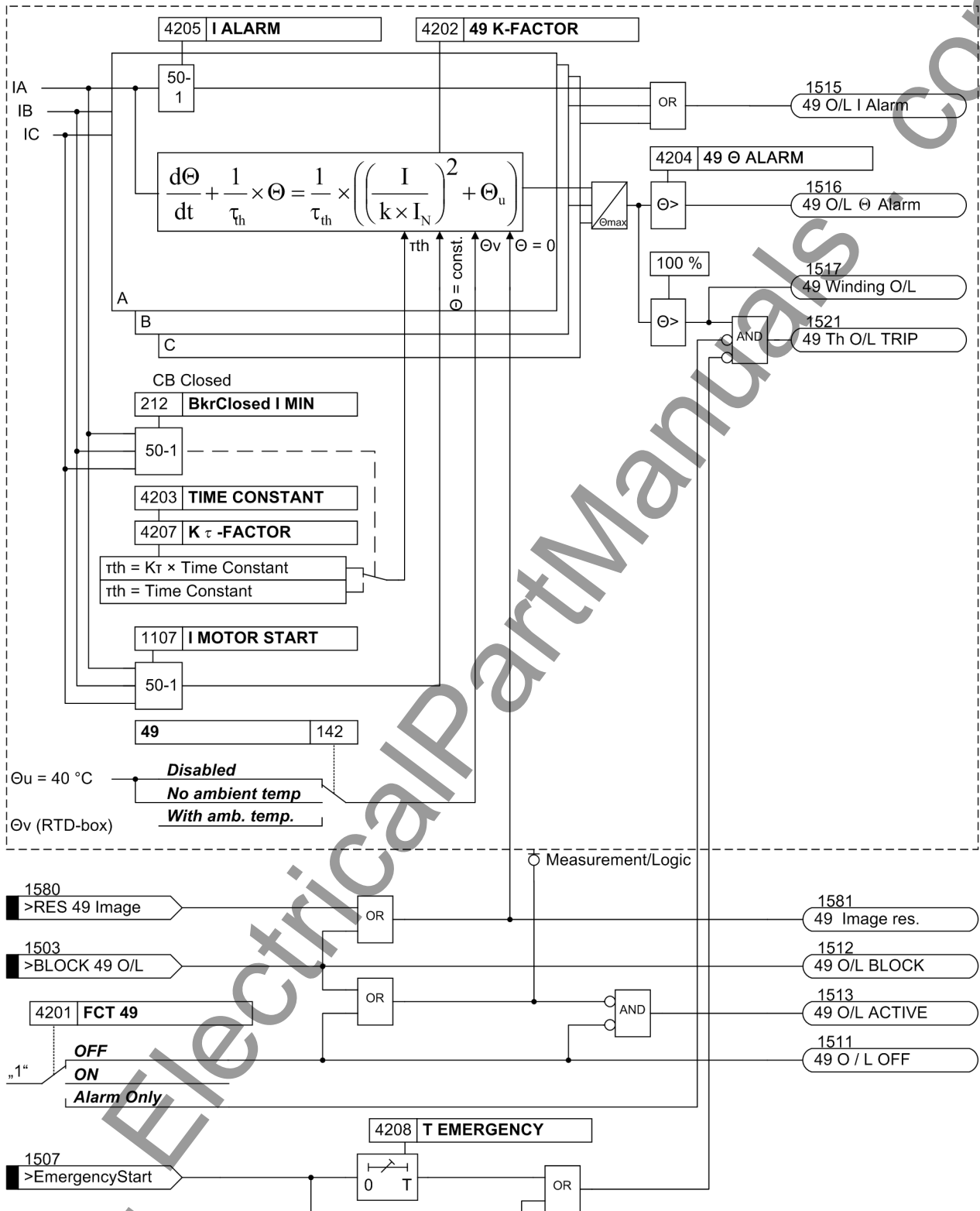

Figure 2-40 Logic diagram of the overload protection

2.7.2 Setting Notes

General

The overload protection is only in effect and accessible if address 142 **49** = **No ambient temp** or = **With amb. temp.** during configuration. If the function is not required **Disabled** is set.

Transformers and cable are prone to damage by overloads that last for an extended period of time. Overloads cannot and should not be detected by fault protection. Time overcurrent protection should be set high enough to only detect faults since these must be cleared in a short time. Short time delays, however, do neither allow measures to discharge overloaded equipment nor do they permit to take advantage of its (limited) overload capacity.

The protective relays 7SJ61 feature a thermal overload protective function with a thermal tripping curve which may be adapted to the overload tolerance of the equipment being protected (overload protection with memory capability).

Overload protection can be switched **ON** or **OFF** or set to **Alarm Only** at address 4201 **FCT 49**. If overload protection is **ON**, tripping, trip log and fault recording is possible.

When setting **Alarm Only** no trip command is given, no trip log is initiated and no spontaneous fault annunciation is shown on the display.



Note

Changing the function parameters resets the thermal replica. The thermal model is frozen (kept constant), as soon as the current exceeds the setting value 1107 **I MOTOR START**.

Overload Parameter k-factor

The overload protection is set in reference values. The nominal current $I_{Nom Obj}$ of the protected object (motor, transformer, cable) is used as the basic current for overload protection. By means of the thermal consistently permissible current I_{max} , a factor k_{prim} can be calculated:

$$k_{prim} = \frac{I_{max prim}}{I_{Nom Obj}}$$

The thermally-permissible continuous current for the equipment being protected is known from the manufacturers specifications. This function is normally not applicable to overhead lines since the current capability of overhead lines is generally not specified. For cables, the permissible continuous current is dependent on the cross-section, insulating material, design, and the cable routing, among other things. It may be taken from pertinent tables, or is specified by the cable manufacturer. If no specifications are available, a value of 1.1 times the nominal current rating may be assumed.

For the **49 K-FACTOR** to be set in the device the following applies (address 4202)

$$\text{Set Value K-FACTOR} \quad k = \frac{I_{\max \text{ prim}}}{I_{\text{Nom Obj.}}} \cdot \frac{I_{\text{Nom Obj.}}}{I_{\text{Nom CT prim}}}$$

with

$I_{\max \text{ prim}}$ Permissible thermal primary current of the motor

$I_{\text{Nom Obj.}}$ Nominal current of the protected object

$I_{\text{Nom CT prim}}$ Nominal primary CT current

Example: Motor and current transformer with the following data:

Permissible Continuous Current

$$I_{\max \text{ prim}} = 1.2 \cdot I_{\text{Nom Obj.}}$$

Nominal Motor Current

$$I_{\text{Nom Obj.}} = 1100 \text{ A}$$

Current Transformer

$$1200 \text{ A} / 1 \text{ A}$$

$$\text{Set Value K-FACTOR:} \quad 1.2 \cdot \frac{1100 \text{ A}}{1200 \text{ A}} = 1.1$$

Time Constant

The overload protection tracks overtemperature progression, employing a thermal differential equation whose steady state solution is an exponential function. The **TIME CONSTANT** τ_{th} (set at address 4203) is used in the calculation to determine the threshold of overtemperature and thus, the tripping temperature.

For cable protection, the heat-gain time constant τ is determined by cable specifications and by the cable environment. If no time-constant specification is available, it may be determined from the short-term load capability of the cable. The 1-sec current, i.e. the maximum current permissible for a one-second period of time, is often known or available from tables. Then, the time constant may be calculated with the formula:

$$\text{Set Value } \tau_{\text{th}} \text{ (min)} = \frac{1}{60} \cdot \left(\frac{I_{1 \text{ sec}}}{I_{\max \text{ prim}}} \right)^2$$

If the short-term load capability is given for an interval other than one second, the corresponding short-term current is used in the above formula instead of the 1-second current, and the result is multiplied by the given duration. For example, if the 0.5-second current rating is known:

$$\text{Set Value } \tau_{\text{th}} \text{ (min)} = \frac{0.5}{60} \cdot \left(\frac{I_{0.5 \text{ sec}}}{I_{\max \text{ prim}}} \right)^2$$

It is important to note, however, that the longer the effective duration, the less accurate the result.

Example: Cable and current transformer with the following data:

Permissible Continuous Current $I_{\max} = 500 \text{ A}$ at $\Theta_u = 40 \text{ °C}$

Maximum Current for 1 s $I_{1s} = 45 \cdot I_{\max} = 22.5 \text{ kA}$

Current Transformer 600 A / 1 A

Example: Cable and current transformer with the following data:

Thus results:

$$k = \frac{I_{\max}}{I_{\text{Nom CT prim}}} = \frac{500 \text{ A}}{600 \text{ A}} = 0.833$$

$$\tau_{\text{th}} = \frac{1}{60} \cdot \left(\frac{I_{1s}}{I_{\max}} \right)^2 \cdot \frac{1}{60} \cdot 45^2 = 33.75 \text{ min}$$

The settings are: **49 K-FACTOR = 0.83; TIME CONSTANT = 33.7 min**

Warning Elements

By setting the thermal warning element **49** \ominus **ALARM** (address 4204), a warning message can be issued before reaching the tripping temperature. Tripping can thus be avoided by initiating early load reduction measures. This warning element simultaneously represents the dropout level for the trip signal. Only when this threshold is undershot, will the tripping command be reset and the protected equipment can be switched on again.

The thermal element level is given in % of the tripping overtemperature.

A current warning level is also available (parameter 4205 **I ALARM**). The setting is in secondary amperes and should be equal to or slightly less than the permissible current $k \cdot I_{\text{N sec}}$. It can be used instead of the thermal warning element by setting the thermal warning element to 100 % thus virtually disabling it

Extension of the time constants

TIME CONSTANT set in address 4203 is valid for a running motor. When a motor without external cooling is running down or at standstill, the motor cools down more slowly. This behavior can be modeled by increasing the time constant by factor **K τ -FACTOR**, set at address 4207. Motor stop is detected if the current falls below the threshold value **BkrClosed I MIN** of the current flow monitoring (see side title "Current Flow Monitoring" in Subsection 2.1.3.2). This implies that the motor idle current is greater than this threshold. The pickup threshold **BkrClosed I MIN** affects also the restart inhibit for motors.

If no distinguishing of the time constants is necessary (e.g. externally-cooled motors, cables, lines, etc.) the **K τ -FACTOR** is set at 1 (default setting value).

Dropout Time after Emergency Starting

The dropout time to be entered at address 4208 **T EMERGENCY** must ensure that after an emergency startup and after dropout of the binary input „>EmergencyStart“ the trip command is blocked until the thermal replica is below the dropout threshold again.

Ambient or Coolant Temperature

The specifications made up to now are sufficient to model the overtemperature. The ambient or coolant temperature, however, can also be processed. This has to be communicated to the device as digitalized measured value via the interface. During configuration, parameter 142 **49** must be set to *With amb. temp.*

If the ambient temperature detection is used, the user must be aware that the **49 K-FACTOR** to be set refers to an ambient temperature of 104° F or 40° C, i.e. it corresponds to the maximum permissible current at a temperature of 104° F or 40° C.

Since all calculations are performed with standardized quantities, the ambient temperature must also be standardized. The temperature at nominal current is used as standardized quantity. If the nominal current deviates from the nominal CT current, the temperature must be adapted according to the formula following. In address 4209 or 4210 **49 TEMP. RISE I** the temperature adapted to the nominal transformer current is set. This setting value is used as standardization quantity for the ambient temperature input.

$$\Theta_{\text{Nom sec}} = \Theta_{\text{Nom Mach}} \cdot \left(\frac{I_{\text{Nom prim CT}}}{I_{\text{Nom Mach}}} \right)^2$$

with

Θ_{Nomsec} Machine temperatur at secondary nominal current = setting at the protection device (address 4209 or 4210)

$\Theta_{\text{Nom Mach}}$ Machine temperature at nominal machine current

$I_{\text{Nom CT prim}}$ Nominal primary CT current

$I_{\text{Nom Mach}}$ Nominal current of the machine

If the temperature input is used, the tripping times change if the coolant temperature deviates from the internal reference temperature of 104° F or 40° C. The following formula can be used to calculate the tripping time:

$$t = \tau_{\text{th}} \cdot \ln \frac{\left(\frac{I}{k \cdot I_{\text{Nom}}} \right)^2 + \frac{\Theta_v - 40^\circ \text{C}}{k^2 \cdot \Theta_{\text{Nom}}} \cdot \left[\left(\frac{I_{\text{pre}}}{k \cdot I_{\text{Nom}}} \right)^2 + \frac{\Theta_{V_{t=0}} - 40^\circ \text{C}}{k^2 \cdot \Theta_{\text{Nom}}} \right] \cdot \left(1 - e^{-\frac{t_{\text{pre}}}{\tau}} \right)}{\left(\frac{I}{k \cdot I_{\text{Nom}}} \right)^2 + \frac{\Theta_v - 40^\circ \text{C}}{k^2 \cdot \Theta_{\text{Nom}}} - 1}$$

with

τ_{th} **TIME CONSTANT** (address 4203)

k **49 K-FACTOR** (address 4202)

I_{Nom} Nominal device current in A

I Fault current through phase in A

I_{Pre} Prefault current

$\Theta_{V_{t=0}}$ Coolant temperature input in °C with t=0

Θ_{Nom} Temperature at nominal current I_{Nom} (address 4209 **49 TEMP. RISE I**)

Θ_v Coolant temperature input (scaling with address 4209 or 4210)

Example:

Machine: $I_{\text{Nom Mach}} = 483 \text{ A}$

$I_{\text{max Mach}} = 1.15 I_{\text{Nom}}$ at $\Theta_K = 40 \text{ }^\circ\text{C}$

$\Theta_{\text{Nom Mach}} = 93 \text{ }^\circ\text{C}$ Temperature at $I_{\text{Nom Mach}}$

$\tau_{\text{th}} = 600 \text{ s}$ (thermal time constant of the machine)

Current transformer: 500 A / 1 A

$$\text{K-FACTOR} = 1.15 \cdot \frac{483 \text{ A}}{500 \text{ A}} \approx 1.11 \quad (\text{to be set in address 4202})$$

$$\vartheta_{\text{Nom sec}} = 93 \text{ }^\circ\text{C} \cdot \left(\frac{500}{483}\right)^2 \approx 100 \text{ }^\circ\text{C} \quad (\text{to be set in address 4209 or 4210 49 TEMP. RISE I})$$

Motor Starting Recognition

The motor starting is detected when setting **I MOTOR START** at address 1107 is exceeded. Information on how to perform the configuration is given under "Recognition of Running Condition (only for motors)" in Subsection 2.1.3.2.

2.7.3 Settings

Addresses which have an appended "A" can only be changed with DIGSI, under "Display Additional Settings".

The table indicates region-specific default settings. Column C (configuration) indicates the corresponding secondary nominal current of the current transformer.

Addr.	Parameter	C	Setting Options	Default Setting	Comments
4201	FCT 49		OFF ON Alarm Only	OFF	49 Thermal overload protection
4202	49 K-FACTOR		0.10 .. 4.00	1.10	49 K-Factor
4203	TIME CONSTANT		1.0 .. 999.9 min	100.0 min	Time Constant
4204	49 Θ ALARM		50 .. 100 %	90 %	49 Thermal Alarm Stage
4205	I ALARM	1A	0.10 .. 4.00 A	1.00 A	Current Overload Alarm Setpoint
		5A	0.50 .. 20.00 A	5.00 A	
4207A	K τ -FACTOR		1.0 .. 10.0	1.0	K τ -FACTOR when motor stops
4208A	T EMERGENCY		10 .. 15000 sec	100 sec	Emergency time
4209	49 TEMP. RISE I		40 .. 200 °C	100 °C	49 Temperature rise at rated sec. curr.
4210	49 TEMP. RISE I		104 .. 392 °F	212 °F	49 Temperature rise at rated sec. curr.

2.7.4 Information List

No.	Information	Type of Information	Comments
1503	>BLOCK 49 O/L	SP	>BLOCK 49 Overload Protection
1507	>EmergencyStart	SP	>Emergency start of motors
1511	49 O / L OFF	OUT	49 Overload Protection is OFF
1512	49 O/L BLOCK	OUT	49 Overload Protection is BLOCKED
1513	49 O/L ACTIVE	OUT	49 Overload Protection is ACTIVE
1515	49 O/L I Alarm	OUT	49 Overload Current Alarm (I alarm)
1516	49 O/L Θ Alarm	OUT	49 Overload Alarm! Near Thermal Trip
1517	49 Winding O/L	OUT	49 Winding Overload
1521	49 Th O/L TRIP	OUT	49 Thermal Overload TRIP
1580	>RES 49 Image	SP	>49 Reset of Thermal Overload Image
1581	49 Image res.	OUT	49 Thermal Overload Image reset

2.8 Monitoring Functions

The device is equipped with extensive monitoring capabilities - both for hardware and software. In addition, the measured values are also constantly monitored for plausibility, therefore, the current transformer and voltage transformer circuits are largely integrated into the monitoring.

2.8.1 Measurement Supervision

2.8.1.1 General

The device monitoring extends from the measuring inputs to the binary outputs. Monitoring checks the hardware for malfunctions and impermissible conditions.

Hardware and software monitoring described in the following are enabled continuously. Settings (including the possibility to activate and deactivate the monitoring function) refer to monitoring of external transformers circuits.

2.8.1.2 Hardware Monitoring

Auxiliary and Reference Voltages

The processor voltage of 5 V DC is monitored by the hardware since the processor will no longer be functional if the voltage falls below the minimum value. In that case, the device is put out of operation. When the supply voltage returns, the processor system is restarted.

Failure of or switching off the supply voltage removes the device from operation and a message is immediately generated by a normally closed contact. Brief auxiliary voltage interruptions of less than 50 ms do not disturb the readiness of the device (for nominal auxiliary voltage > 110 VDC).

The processor monitors the offset and reference voltage of the ADC (analog-digital converter). The protection is suspended if the voltages deviate outside an allowable range, and lengthy deviations are reported.

Buffer Battery

The buffer battery, which ensures operation of the internal clock and storage of counters and messages if the auxiliary voltage fails, is periodically checked for charge status. If it is less than an allowed minimum voltage, then the „Fail Battery“ message is issued.

Memory Components

All working memories (RAMs) are checked during startup. If a malfunction occurs then, the starting sequence is interrupted and an LED blinks. During operation the memories are checked with the help of their checksum. For the program memory, the cross sum is formed cyclically and compared to the stored program cross sum.

For the settings memory, the cross sum is formed cyclically and compared to the cross sum that is freshly generated each time a setting process takes place.

If a fault occurs the processor system is restarted.

Scanning

Scanning and the synchronization between the internal buffer components are constantly monitored. If any deviations cannot be removed by renewed synchronization, then the processor system is restarted.

Measurement Value Acquisition – Currents

The monitoring of the device-internal measured-value acquisition of the currents can be effected via the current sum monitoring.

Up to four input currents are measured by the device. If the three phase currents and the ground current from the current transformer starpoint are connected with the device, the sum of the four digitized currents must be zero. This also applies in the event of a possible transformer saturation. For that reason – in order to eliminate pickup upon transformer saturation – this function is only available in a Holmgreen-connection (see also 2.1.3.2). Faults in the current circuits are recognized if

$$I_F = |i_A + i_B + i_C + i_N| > \Sigma \text{ I THRESHOLD} \cdot I_{Nom} + \Sigma \text{ I FACTOR} \cdot I_{max}$$

$\Sigma \text{ I THRESHOLD}$ 8106 and $\Sigma \text{ I FACTOR}$ 8107 are programmable settings. The component $\Sigma \text{ I FACTOR} \cdot I_{max}$ takes into account the permissible current proportional ratio errors of the input transformer which are particularly prevalent during large short-circuit currents (Figure 2-41). The dropout ratio is about 97%.

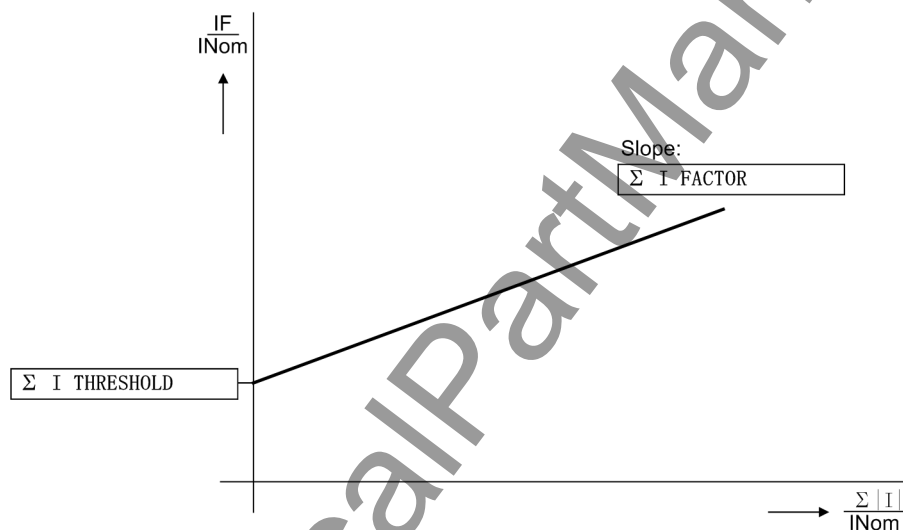

Figure 2-41 Current Sum Monitoring

An error in the current sum results in the message „Failure $\Sigma \text{ I}$ “ (No. 162) and blocking of the protection function. Furthermore, a fault log is initiated for a period of 100 ms.

The monitoring can be switched off.

The monitoring is available subject to the following conditions:

- The three phase currents are connected to the device (address 251 **A, B, C, (Gnd)**)
- The ground current of the current transformer starpoint is connected to the fourth current input (I_4) (Holmgreen-connection). This is communicated to the device in the **Power System Data 1** via address 280 **YES**.
- The fourth current input is normally designed for a I_4 -transformer. In case of a sensitive transformer type, this monitoring is not available.
- The settings **CT PRIMARY** (address 204) and **Ignd-CT PRIM** (address 217) must be the same.
- The settings **CT SECONDARY** (address 205) and **Ignd-CT SEC** (address 218) must be the same.

The following logic diagram illustrates the operational mode of the current sum monitoring.

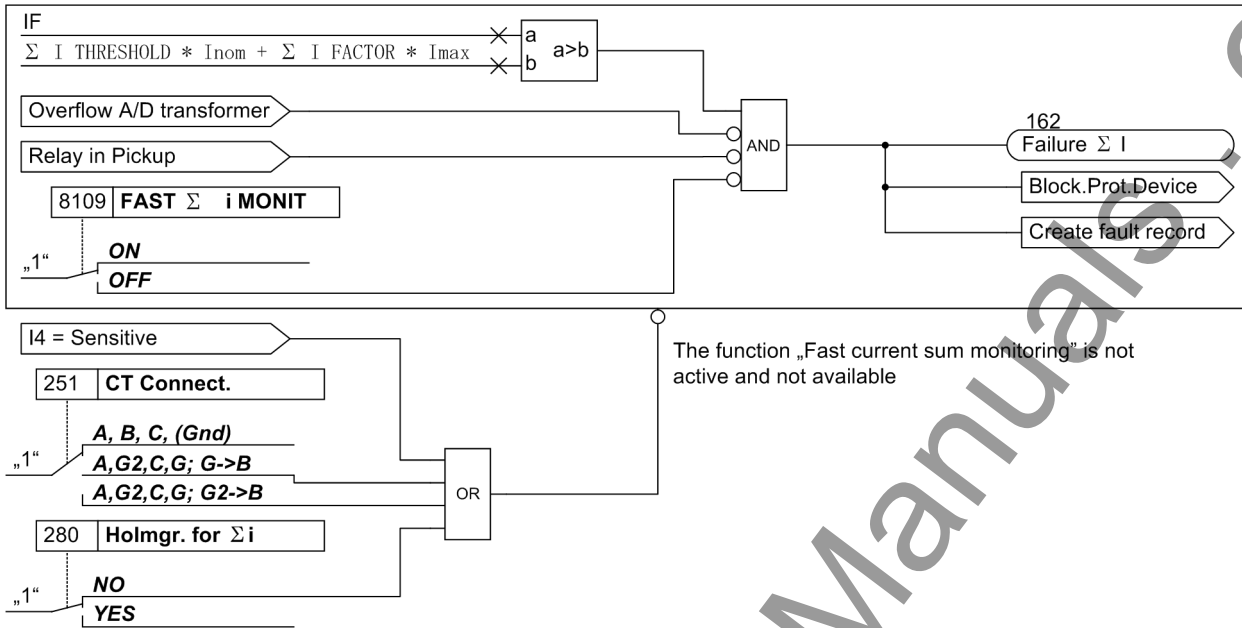

Figure 2-42 Logic Diagram of the fast current sum monitoring

AD Transformer Monitoring

The digitized sampled values are being monitored in respect of their plausibility. If the result is not plausible, message 181 „Error A/D- conv. “ is issued. The protection is blocked, thus preventing unwanted operation. Furthermore, a fault record is generated for recording of the internal fault.

2.8.1.3 Software Monitoring

Watchdog

For continuous monitoring of the program sequences, a time monitor is provided in the hardware (hardware watchdog) that expires upon failure of the processor or an internal program, and causes a complete restart of the processor system.

An additional software watchdog ensures that malfunctions during the processing of programs are discovered. This also initiates a restart of the processor system.

If such a malfunction is not cleared by the restart, an additional restart attempt is begun. After three unsuccessful restarts within a 30 second window of time, the device automatically removes itself from service and the red „Error“ LED lights up. The readiness relay drops out and indicates „device malfunction“ with its normally closed contact.

Offset Monitoring

This monitoring function checks all ring buffer data channels for corrupt offset replication of the analog/digital transformers and the analog input paths using offset filters. Any possible offset errors are detected using DC voltage filters and the associated samples are corrected up to a specific limit. If this limit is exceeded, an annunciation is issued (191 „Error Offset“) that is part of the warn group annunciation (annunciation 160). As increased offset values affect the reliability of measurements taken, we recommend to send the device to the OEM plant for corrective action if this annunciation continuously occurs.

2.8.1.4 Monitoring of the External Transformer Circuits

Interruptions or short-circuits in the secondary circuits of the current and voltage transformers, as well as faults in the connections (important for commissioning), are detected and reported by the device. The measured quantities are cyclically checked in the background for this purpose, as long as no system fault is present.

Current Symmetry

During normal system operation, a certain symmetry among the input currents is expected. The monitoring of the measured values in the device checks this balance. The smallest phase current is compared to the largest phase current. Asymmetry is detected if $|I_{min}| / |I_{max}| < \text{BAL. FACTOR I}$ as long as $I_{max} / I_{Nom} > \text{BALANCE I LIMIT} / I_{Nom}$.

Thereby I_{max} is the largest of the three phase currents and I_{min} the smallest. The symmetry factor **BAL. FACTOR I** (address 8105) represents the allowable asymmetry of the phase currents while the limit value 8105 (address 8104) is the lower limit of the operating range of this monitoring (see Figure 2-43). Both parameters can be set. The dropout ratio is about 97%.

This malfunction is reported as „Fail I balance“.

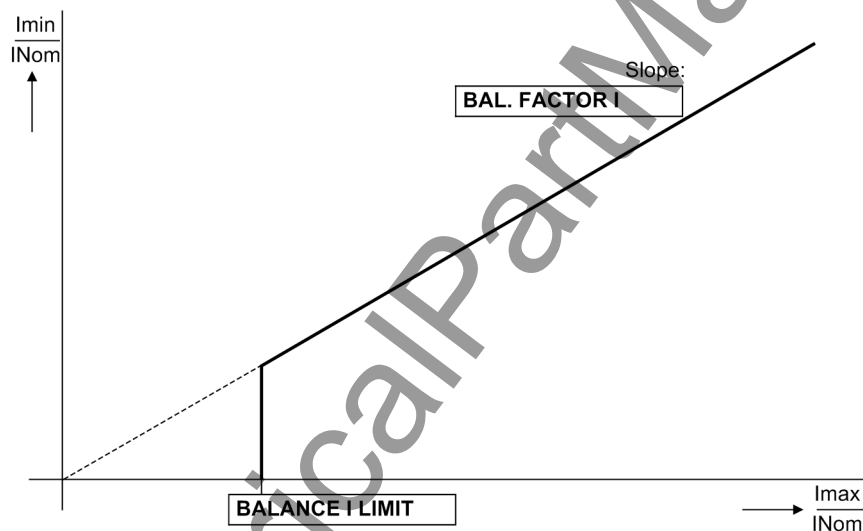

Figure 2-43 Current symmetry monitoring

Phase Sequence

To detect swapped phase connections in the current input circuits, the direction of rotation of the phase currents is checked. Therefore the sequence of the zero crossings of the currents (having the same sign) is checked.

The default setting assumes a positive phase sequence.

Currents: I_A leads I_B leads I_C

Supervision of current rotation requires a maximum current of

$$|I_A|, |I_B|, |I_C| > 0,5 I_{Nom}$$

For abnormal phase sequence, the message „Fail Ph. Seq. I“ is issued.

For applications in which an opposite phase sequence is expected, the protective relay should be adjusted via a binary input or the respective parameter **PHASE SEQ.** (address 209). If the phase sequence is changed in the device, phases B and C internal to the relay are reversed, and the positive and negative sequence currents are thereby exchanged (see also Section 2.15.2). The phase-related messages, malfunction values, and measured values are not affected by this.

2.8.1.5 Setting Notes

Measured Value Monitoring

The sensitivity of measured value monitor can be modified. Default values are set at the factory, which are sufficient in most cases. If an extremely high operational unbalance of the currents is to be expected in the specific application, or if during operation monitoring functions are operated sporadically, the relevant parameters should be set less sensitive.

Address 8104 **BALANCE I LIMIT** determines the limit current, above which the current symmetry monitor is effective. Address 8105 **BAL. FACTOR I** is the associated symmetry factor; that is, the slope of the symmetry characteristic curve.

Address 8106 **I THRESHOLD** determines the limit current, above which the current sum monitor is activated (absolute portion, only relative to I_{Nom}). The relative portion (relative to the maximum conductor current) for activating the current sum monitor is set at address 8107 **I FACTOR**.



Note

Current sum monitoring can operate properly only when the residual current of the protected line is fed to the fourth current input (I_N) of the relay (see **Power System Data 1**). Furthermore, the fourth current input (I_N) may not be sensitive.



Note

The connections of the ground paths and their adaption factors were set when configuring the general Power System Data. These settings must be correct for the measured values monitoring to function properly.

Measured value monitoring can be turned **ON** or **OFF** at address 8101 **MEASURE. SUPERV.**

2.8.1.6 Settings

The table indicates region-specific default settings. Column C (configuration) indicates the corresponding secondary nominal current of the current transformer.

Addr.	Parameter	C	Setting Options	Default Setting	Comments
8101	MEASURE. SUPERV		OFF ON	ON	Measurement Supervision
8104	BALANCE I LIMIT	1A	0.10 .. 1.00 A	0.50 A	Current Threshold for Balance Monitoring
		5A	0.50 .. 5.00 A	2.50 A	
8105	BAL. FACTOR I		0.10 .. 0.90	0.50	Balance Factor for Current Monitor
8106	Σ I THRESHOLD	1A	0.05 .. 2.00 A; ∞	0.10 A	Summated Current Monitoring Threshold
		5A	0.25 .. 10.00 A; ∞	0.50 A	
8107	Σ I FACTOR		0.00 .. 0.95	0.10	Summated Current Monitoring Factor
8109	FAST Σ i MONIT		OFF ON	ON	Fast Summated Current Monitoring

2.8.1.7 Information List

No.	Information	Type of Information	Comments
161	Fail I Superv.	OUT	Failure: General Current Supervision
162	Failure Σ I	OUT	Failure: Current Summation
163	Fail I balance	OUT	Failure: Current Balance
175	Fail Ph. Seq. I	OUT	Failure: Phase Sequence Current
197	MeasSup OFF	OUT	Measurement Supervision is switched OFF

2.8.2 Trip Circuit Supervision 74TC

Devices 7SJ61 are equipped with an integrated trip circuit supervision. Depending on the number of available binary inputs (not connected to a common potential), supervision with one or two binary inputs can be selected. If the allocation of the required binary inputs does not match the selected supervision type, then a message to this effect is generated („74TC ProgFail“).

Applications

- When using two binary inputs, malfunctions in the trip circuit can be detected under all circuit breaker conditions.
- When only one binary input is used, malfunctions in the circuit breaker itself cannot be detected.

Prerequisites

A requirement for the use of trip circuit supervision is that the control voltage for the circuit breaker is at least twice the voltage drop across the binary input ($V_{ct} > 2 \cdot V_{BImin}$).

Since at least 19 V are needed for the binary input, the supervision can only be used with a system control voltage of over 38 V.

2.8.2.1 Description

Supervision with Two Binary Inputs

When using two binary inputs, these are connected according to Figure 2-44, parallel to the associated trip contact on one side, and parallel to the circuit breaker auxiliary contacts on the other.

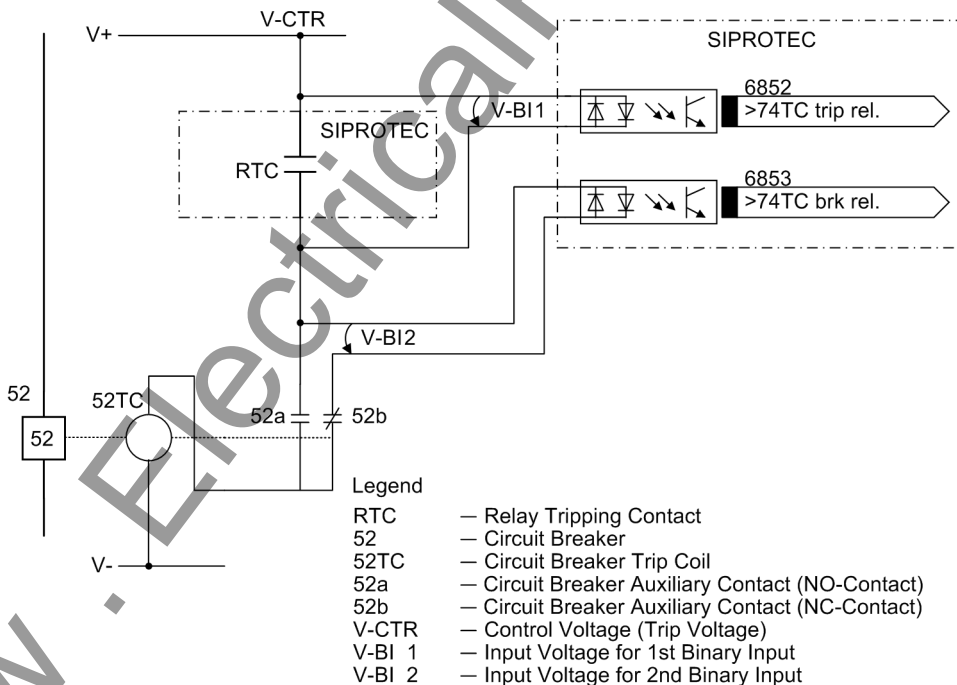

Figure 2-44 Principle of the trip circuit supervision with two binary inputs

Supervision with two binary inputs not only detects interruptions in the trip circuit and loss of control voltage, it also supervises the response of the circuit breaker using the position of the circuit breaker auxiliary contacts.

Depending on the conditions of the trip contact and the circuit breaker, the binary inputs are activated (logical condition "H" in Table 2-5), or not activated (logical condition "L").

In healthy trip circuits the condition that both binary inputs are not actuated ("L") is only possible during a short transition period (trip contact is closed but the circuit breaker has not yet opened). A continuous state of this condition is only possible when the trip circuit has been interrupted, a short-circuit exists in the trip circuit, a loss of battery voltage occurs, or malfunctions occur with the circuit breaker mechanism. Therefore, it is used as supervision criterion.

Table 2-5 Condition table for binary inputs, depending on RTC and CB position

No.	Trip contact	Circuit breaker	52a Contact	52b Contact	BI 1	BI 2
1	Open	Closed	Closed	Open	H	L
2	Open	Open	Open	Closed	H	H
3	Closed	Closed	Closed	Open	L	L
4	Closed	Open	Open	Closed	L	H

The conditions of the two binary inputs are checked periodically. A check takes place about every 600 ms. If three consecutive conditional checks detect an abnormality (after 1.8 s), an annunciation is reported (see Figure 2-45). The repeated measurements determine the delay of the alarm message and avoid that an alarm is output during short transition periods. After the malfunction in the trip circuit is cleared, the fault annunciation is reset automatically after the same time period.

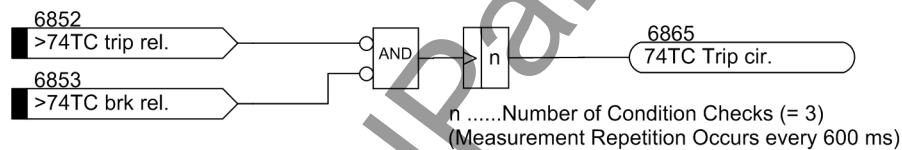

Figure 2-45 Logic diagram of the trip circuit supervision with two binary inputs

Supervision with One Binary Input

The binary input is connected according to the following figure in parallel with the associated trip contact of the protection relay. The circuit breaker auxiliary contact is bridged with a bypass resistor R.

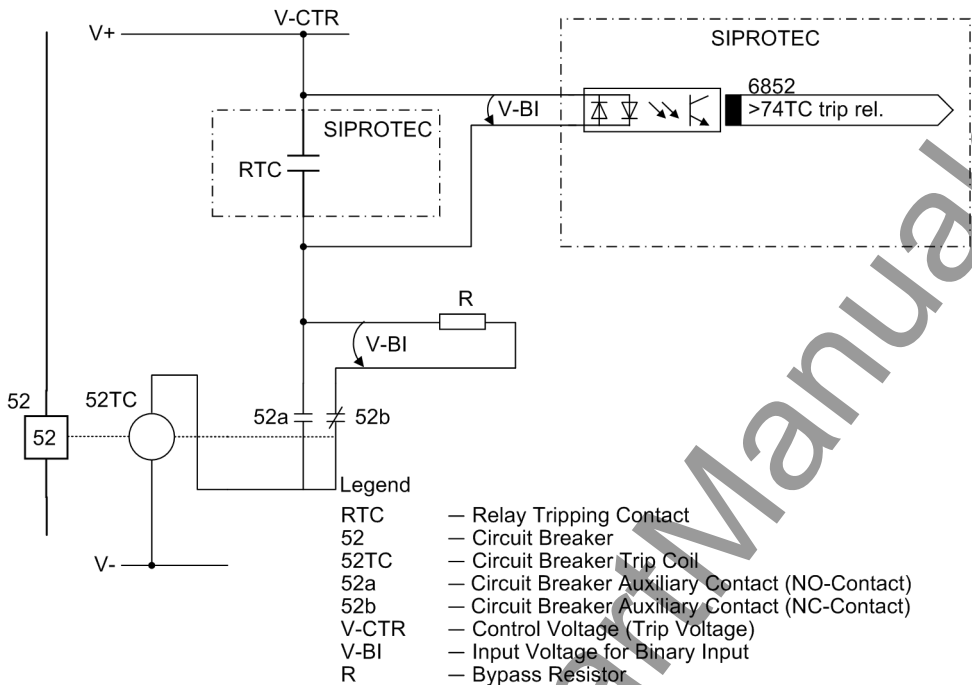

Figure 2-46 Trip circuit supervision with one binary input

During normal operation, the binary input is activated (logical condition "H") when the trip contact is open and the trip circuit is intact, because the monitoring circuit is closed by either the 52a circuit breaker auxiliary contact (if the circuit breaker is closed) or through the bypass resistor R by the 52b circuit breaker auxiliary contact. Only as long as the trip contact is closed, the binary input is short circuited and thereby deactivated (logical condition "L").

If the binary input is continuously deactivated during operation, this leads to the conclusion that there is an interruption in the trip circuit or loss of control voltage.

As the trip circuit supervision does not operate during system faults, the closed trip contact does not lead to a fault message. If, however, tripping contacts from other devices operate in parallel with the trip circuit, then the fault message must be delayed (see also Figure 2-47). The delay time can be set via parameter **8202 Alarm Delay**. A message is only released after expiry of this time. After clearance of the fault in the trip circuit, the fault message is automatically reset.

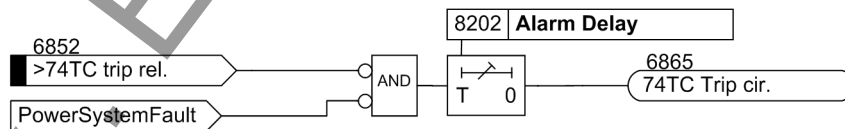

Figure 2-47 Logic diagram of trip circuit supervision with one binary input

The following figure shows the logic diagram for the message that can be generated by the trip circuit monitor, depending on the control settings and binary inputs.

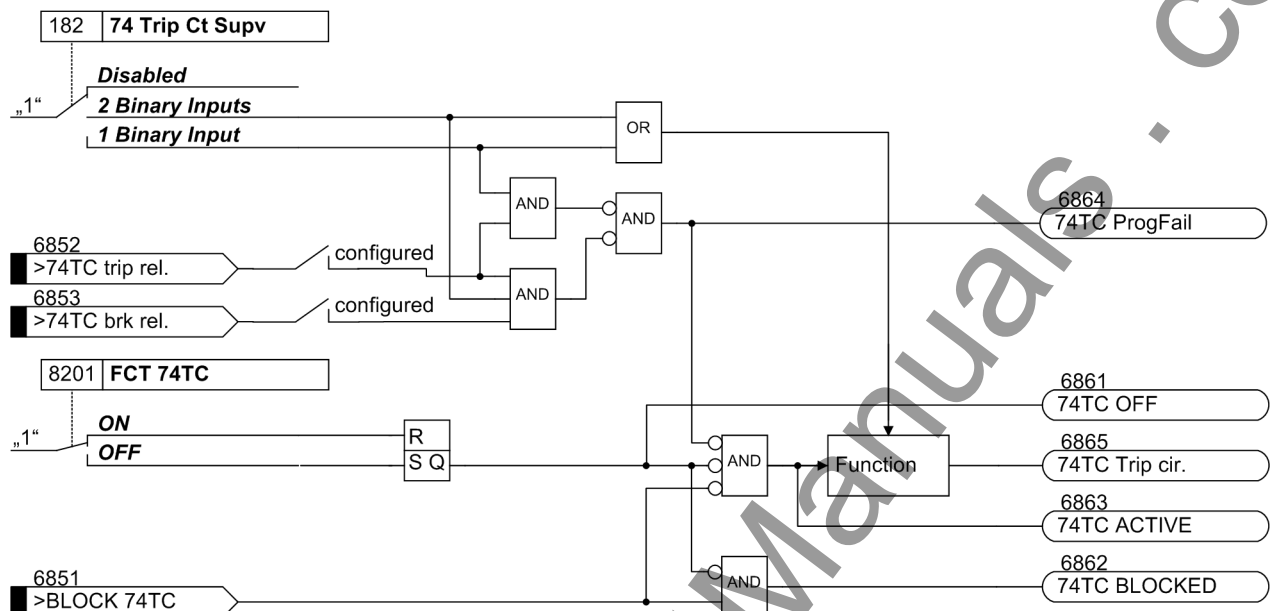

Figure 2-48 Message logic for trip circuit supervision

2.8.2.2 Setting Notes

General

The function is only effective and accessible if address 182 (Section 2.1.1.2) was set to either **2 Binary Inputs** or **1 Binary Input** during configuration, the appropriate number of binary inputs has been configured accordingly for this purpose and the function **FCT 74TC** is **ON** at address 8201. If the allocation of the required binary inputs does not match the selected supervision type, a message to this effect is generated („74TC ProgFail“). If the trip circuit monitor is not to be used at all, then **Disabled** is set at address 182.

In order to ensure that the longest possible duration of a trip command can be reliably bridged, and an indication is generated in case of an actual fault in the trip circuit, the indication regarding a trip circuit interruption is delayed. The time delay is set under address 8202 **Alarm Delay**.

Supervision with One Binary Input

Note: When using only one binary input (BI) for the trip circuit monitor, malfunctions, such as interruption of the trip circuit or loss of battery voltage are detected in general, but trip circuit failures while a trip command is active cannot be detected. Therefore, the measurement must take place over a period of time that bridges the longest possible duration of a closed trip contact. This is ensured by the fixed number of measurement repetitions and the time between the state checks.

When using only one binary input, a resistor R is inserted into the circuit on the system side, instead of the missing second binary input. Through appropriate sizing of the resistor and depending on the system conditions, a lower control voltage is mostly sufficient.

Information for dimensioning resistor R is given in the Chapter "Installation and Commissioning" under Configuration Notes in the Section "Trip Circuit Supervision".

2.8.2.3 Settings

Addr.	Parameter	Setting Options	Default Setting	Comments
8201	FCT 74TC	ON OFF	ON	74TC TRIP Circuit Supervision
8202	Alarm Delay	1 .. 30 sec	2 sec	Delay Time for alarm

2.8.2.4 Information List

No.	Information	Type of Information	Comments
6851	>BLOCK 74TC	SP	>BLOCK 74TC
6852	>74TC trip rel.	SP	>74TC Trip circuit superv.: trip relay
6853	>74TC brk rel.	SP	>74TC Trip circuit superv.: bkr relay
6861	74TC OFF	OUT	74TC Trip circuit supervision OFF
6862	74TC BLOCKED	OUT	74TC Trip circuit supervision is BLOCKED
6863	74TC ACTIVE	OUT	74TC Trip circuit supervision is ACTIVE
6864	74TC ProgFail	OUT	74TC blocked. Bin. input is not set
6865	74TC Trip cir.	OUT	74TC Failure Trip Circuit

2.8.3 Malfunction Responses of the Monitoring Functions

In the following malfunction responses of monitoring equipment are clearly listed.

2.8.3.1 Description

Malfunction Responses

Depending on the type of malfunction discovered, an annunciation is sent, a restart of the processor system is initiated, or the device is taken out of service. After three unsuccessful restart attempts, the device is taken out of service. The operational readiness NC contact operates to indicate the device is malfunctioning. Also, the red LED "ERROR" lights up on the front cover, if the internal auxiliary voltage is present, and the green "RUN" LED goes out. If the internal auxiliary voltage fails, all LEDs are dark. Table 2-6 provides a summary of the monitoring functions and the malfunction responses of the relay.

Table 2-6 Summary of malfunction responses by the protection relay

Monitoring	Possible Causes	Malfunction Response	Message (No.)	Output
Auxiliary supply voltage loss	External (aux. voltage), internal (converter)	Device shutdown	All LEDs dark	DOK ⁽²⁾ drops out
Internal supply voltages	Internal (power supply)	Device shutdown	LED "ERROR"	DOK ⁽²⁾ drops out
Back-up battery	Internal (battery)	Message	„Fail Battery“ (177)	
Hardware watchdog	Internal (processor failure)	Device shutdown	LED "ERROR"	DOK ⁽²⁾ drops out
Software watchdog	Internal (processor failure)	Restart attempt ¹⁾	LED "ERROR"	DOK ⁽²⁾ drops out
Working memory	Internal (hardware)	Relay aborts restart, device shutdown	LED flashes	DOK ⁽²⁾ drops out
Program memory	Internal (hardware)	During startup	LED "ERROR"	DOK ⁽²⁾ drops out
		During operation: Restart attempt ¹⁾	LED "ERROR"	
Settings	Internal (hardware)	Restart attempt ¹⁾	LED "ERROR"	DOK ⁽²⁾ drops out
Scanning frequency	Internal (hardware)	Device shutdown	LED "ERROR"	DOK ⁽²⁾ drops out
Measured value acquisition	External (hardware)	Blocking by the protection function	„Error A/D-conv.“ (181), LED "ERROR"	DOK ⁽²⁾ drops out
Error in the I/O-board	Internal (hardware)	Device shutdown	„I/O-Board error“ (178), LED "ERROR"	DOK ⁽²⁾ drops out
Module error	Internal (hardware)	Device shutdown	„Error Board 1“ to „Error Board 7“ (178 to 189), LED "ERROR"	DOK ⁽²⁾ drops out
Internal auxiliary voltage 5 V	Internal (hardware)	Device shutdown	„Error 5V“ (144), LED "ERROR"	DOK ⁽²⁾ drops out
0 V-Monitoring	Internal (hardware)	Device shutdown	„Error 0V“ (145), LED "ERROR"	DOK ⁽²⁾ drops out
Internal auxiliary voltage -5 V	Internal (hardware)	Device shutdown	„Error -5V“ (146), LED "ERROR"	DOK ⁽²⁾ drops out
Offset Monitoring	Internal (Hardware)	Device shutdown	„Error Offset“ (191)	DOK ⁽²⁾ drops out
Internal supply voltages	Internal (hardware)	Device shutdown	„Error PwrSupply“ (147), LED "ERROR"	DOK ⁽²⁾ drops out
Current sum	Internal (measured value acquisition)	Message	„Failure ΣI “ (162)	As allocated
Current symmetry	External (power system or current transformer)	Message	„Fail I balance“ (163)	As allocated
Current rotation	External (power system or connection)	Message	„Fail Ph. Seq. I“ (175)	As allocated
Trip circuit monitoring	External (trip circuit or control voltage)	Message	„74TC Trip cir.“ (6865)	As allocated
Calibration data fault	Internal (Hardware)	Message	„Alarm NO calibr“ (193)	As allocated

¹⁾ After three unsuccessful restarts, the device is taken out of service.

²⁾ DOK = "Device Okay" = Ready for service relay drops off, protection and control functions are blocked.

Group Alarms

Certain messages of the monitoring functions are already combined to group alarms. A listing of the group alarms and their composition is given in the Appendix A.10. In this case, it must be noted that message 160 „Alarm Sum Event“ is only issued when the measured value monitoring functions (8101 **MEASURE.SUPERV**) are activated.

2.9 Ground Fault Protection 50N(s), 51N(s)

Depending on the variant, the fourth current input of the multi-functional protection relays 7SJ61 is equipped either with a sensitive input transformer or a standard transformer for 1/5 A.

In the first case, the protective function is designed for ground fault detection in isolated or compensated systems due to its high sensitivity. It is not really suited for ground fault detection with large ground currents since the linear range is transcended at about 1.5 A at the sensitive ground fault detection relay terminals.

If the relay is equipped with standard transformers for 1/5 A, also large currents can be detected correctly.

Applications

- Sensitive ground fault detection may be used in isolated or compensated systems to detect ground faults.
- In solidly or low-resistance grounded systems, sensitive ground fault detection is used to detect high impedance ground faults.
- This function can also be used as supplementary ground fault protection.

2.9.1 Current Elements 50Ns, 51Ns

The current elements for ground faults operate with the magnitudes of the ground current. They only make sense where the magnitude of the ground current can be used to specify the ground fault. This may be the case on grounded systems (solid or low-resistance) or on electrical machines which are directly connected to the busbar of an isolated power system, when in case of a network ground fault the machine supplies only a negligible ground fault current across the measurement location, which must be situated between the machine terminals and the network, whereas in case of a machine ground fault the higher ground fault current produced by the total network is available. Ground current protection is mostly used as backup protection for high resistance ground faults in solid or low resistance grounded systems when main fault protection does not pickup.

For ground fault detection, a two-step current/time characteristic can be set. Analogously to the time overcurrent protection, the high-set current element is designated as **50Ns-2 PICKUP** and **50Ns-2 DELAY** and is provided with a definite time characteristic. The overcurrent element may be operated with either a definite time delay (**50Ns-1 PICKUP** and **50Ns-1 DELAY**) or with a user-defined characteristic (**51Ns PICKUP** and **51Ns TIME DIAL**). Additionally, a current element with logarithmic inverse characteristic or logarithmic inverse characteristic with knee point is implemented. The characteristics of these current elements can be configured.

Settable Dropout Times

The pickup can be stabilized for ground fault protection with definite time curve by a settable dropout time. This facility is used in power systems with intermittent faults. Used together with electromechanical relays, it allows different dropout responses to be adjusted and time grading of digital and electromechanical relays to be implemented.

2.9.2 Logic

The following figure illustrates a state logic of the sensitive ground fault protection. The ground fault detection can be turned *ON* or (address 3101). When ground fault protection is *ON*, tripping is possible. The entire function may be blocked via binary input. Switching off or blocking means the measurement logic shown in Figure 2-50 is deactivated. Therefore, time delays and pickup messages are reset.

All elements can be blocked individually via binary inputs. In this case, pickups are still reported but tripping is prevented because the time stages are blocked.

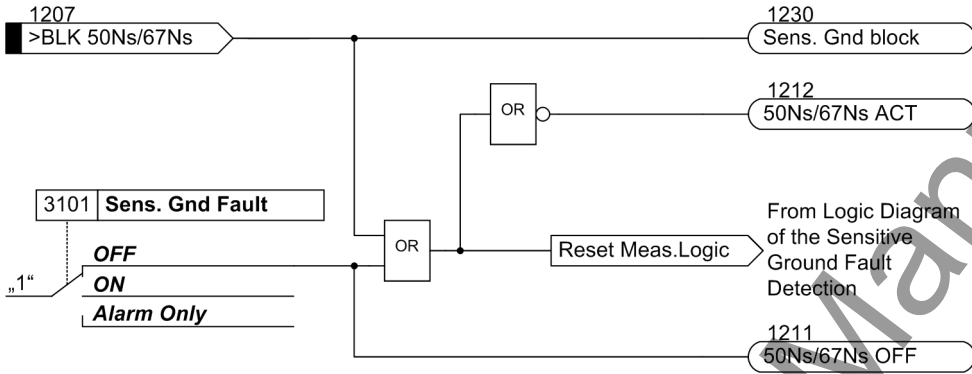

Figure 2-49 Activation of the sensitive ground current protection

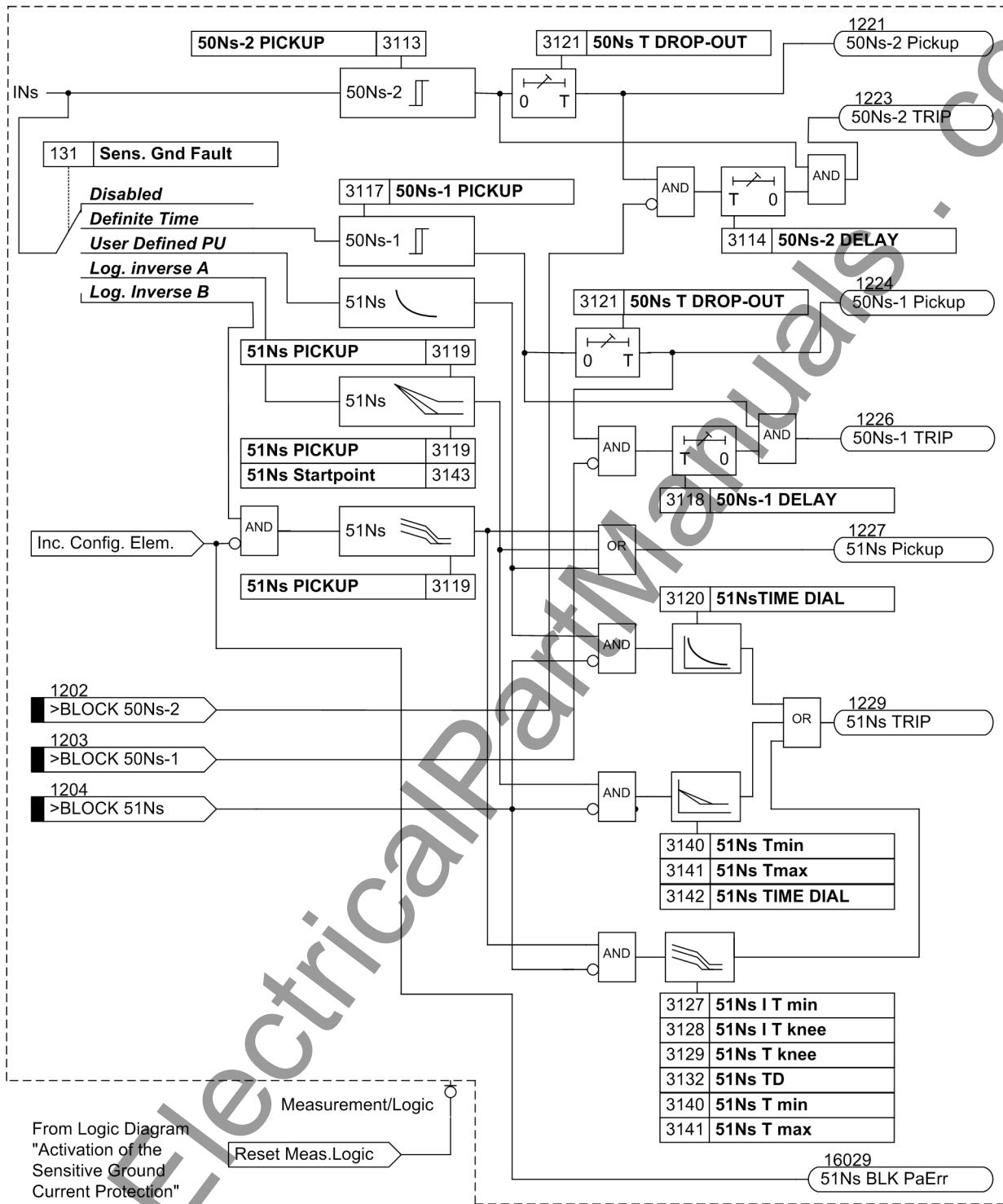

Figure 2-50 Logic diagram of the sensitive ground fault protection

The pickup of the definite time overcurrent protection can be stabilized by the configurable dropout time 3121 **50Ns T DROP-OUT**. This time is started and maintains the pickup condition if the current falls below the threshold. Therefore, the function does not drop out at high speed. The trip command delay time continues running. After the dropout delay time has elapsed, the pickup is reported OFF and the trip delay time is reset unless the threshold has been exceeded again. If the threshold is exceeded again during the dropout delay time, the time is cancelled. The trip command delay time continues running. If the threshold value is exceeded after its expiry, the trip command is issued immediately. If the threshold value is not exceeded at this time, there is no reaction. If the threshold value is exceeded again after expiry of the trip-command delay time, while the dropout delay time is still running, tripping occurs immediately.

2.9.3 Setting Notes

General Settings

The operating mode of the protective function is configured at address 131 **Sens. Gnd Fault** (see Section 2.1.1). If address **Sens. Gnd Fault = Definite Time**, then only the settings for the definite-time elements are available. If the setting is **Sens. Gnd Fault = Log. inverse A**, a logarithmic inverse characteristic is available. If the setting is **Sens. Gnd Fault = Log. Inverse B**, a logarithmic inverse characteristic with knee point is active. Alternatively, user-defined characteristic can be used when setting **Sens. Gnd Fault = User Defined PU**. The superimposed high-set element 50Ns-2 is available in all these cases. If the function is not required, **Disabled** is set.

Sensitive ground fault detection may be switched **ON** or **OFF** or to **Alarm Only** in address 3101 **Sens. Gnd Fault**. If sensitive ground fault protection is switched **ON**, both tripping and message reporting is possible.

A two-stage current/time characteristic may be set at addresses 3113 through 3120. These elements operate with the ground current magnitude. They only make sense where the magnitude of the ground current can be used to specify the ground fault. This may be the case on grounded systems (solid or low-resistance) or on electrical machines which are directly connected to the busbar of an ungrounded power system, when in case of a network ground fault the machine supplies only a negligible ground fault current across the measurement location, which must be situated between the machine terminals and the network, whereas in case of a machine ground fault the total ground fault current produced by the total network is available.

50Ns-2 Element (Definite Time)

Similar to the time overcurrent protection function the high set element is named **50Ns-2 PICKUP** (address 3113). It is delayed with **50Ns-2 DELAY** (address 3114) and may be set to generate a message or to trip. The latter is only possible if address 3101 **Sens. Gnd Fault** is set to **ON**.

50Ns-1 Element (Definite Time)

The definite tripping characteristic 50Ns-1 is set with addresses 3117 and 3118 (address 131 **Sens. Gnd Fault = Definite Time**).

Pickup Stabilization (Definite Time)

Pickup of the definite time elements can be stabilized by means of a configurable dropout time. This dropout time is set in 3121 **50Ns T DROP-OUT**.

51Ns Element (Inverse Time)

The inverse tripping characteristic 51N-TOC is set with addresses 3119 and 3120 (address 131 **Sens. Gnd Fault = User Defined PU**).

Logarithmic Inverse characteristic (Inverse Time)

The logarithmic inverse characteristic (see Figure 2-51) is set in parameters 3119 **51Ns PICKUP**, 3141 **51Ns Tmax**, 3140 **51Ns Tmin**, 3142 **51Ns TIME DIAL** and 3143 **51Ns Startpoint**. **51Ns Tmin** and **51Ns Tmax** define the tripping time range. The slope of the curve is defined by 3142 **51Ns TIME DIAL**. **51Ns PICKUP** is the reference value for all current values with **51Ns Startpoint** representing the beginning of the curve, i.e. the lower operating range on the current axis (referred to **51Ns PICKUP**). This factor is preset to the value 1.1, analogously to the other inverse time curves. This factor can also be set to 1.0 since in logarithmic inverse curves the tripping time on a current value, which is identical to the specified pickup threshold, does not go towards infinity, but has a finite time value.

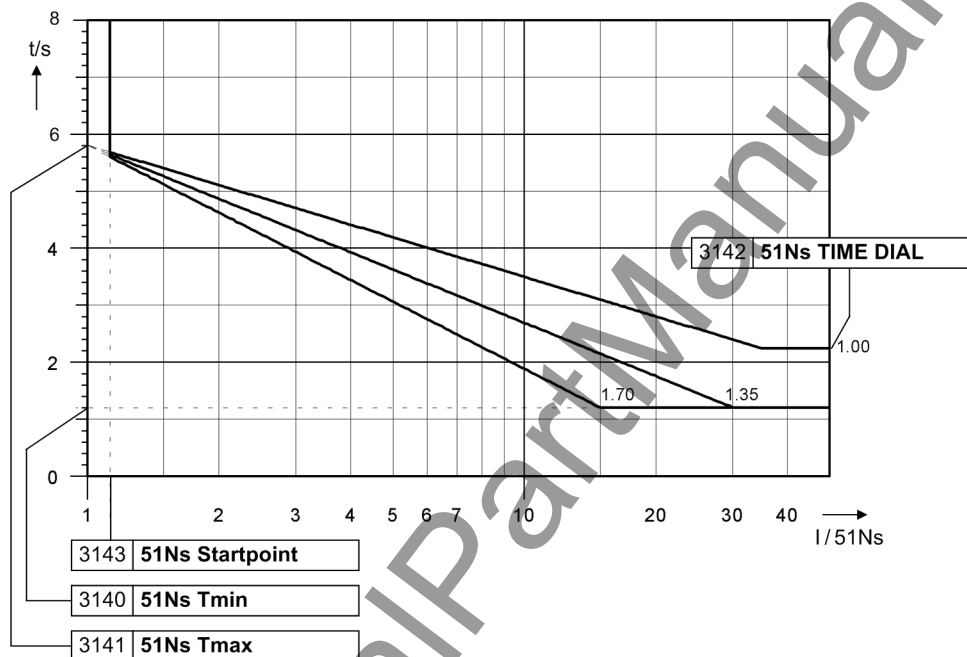

Figure 2-51 Trip time characteristics of inverse time ground fault protection with logarithmic inverse characteristic

Logarithmic inverse $t = 51Ns \text{ MAX. TIME DIAL} - 51Ns \text{ TIME DIAL} \cdot \ln(I/51Ns \text{ PICKUP})$

Note: For $I/51Ns \text{ PICKUP} > 35$ the time applies for $I/51Ns \text{ PICKUP} = 35$

Logarithmic Inverse characteristic with Knee Point (inverse time)

The logarithmic inverse curve with knee point (see figure 2-52) is set with the parameters 3119 **51Ns PICKUP**, 3127 **51Ns I T min**, 3128 **51Ns I T knee**, 3132 **51Ns TD**, 3140 **51Ns T min** and 3141 **51Ns T max**. **51Ns T min** and **51Ns T max** determine the tripping time range with **51Ns T max** of the current threshold **51Ns PICKUP** and **51Ns T min** of the current threshold **51Ns I T min** assigned. When configuring the knee point time **51Ns T knee**, the tripping time is determined at transition of the two curve sections with different slopes. The point of transition is defined by the current threshold **51Ns I T knee**. **51Ns PICKUP** represents the minimum pickup limit for the ground fault pickup current of the overcurrent element. After a maximum secondary current of 1.4 A has been reached, the tripping time assumes a constant value. Parameter **51Ns TD** serves as a time multiplier for multiplication of the tripping time.

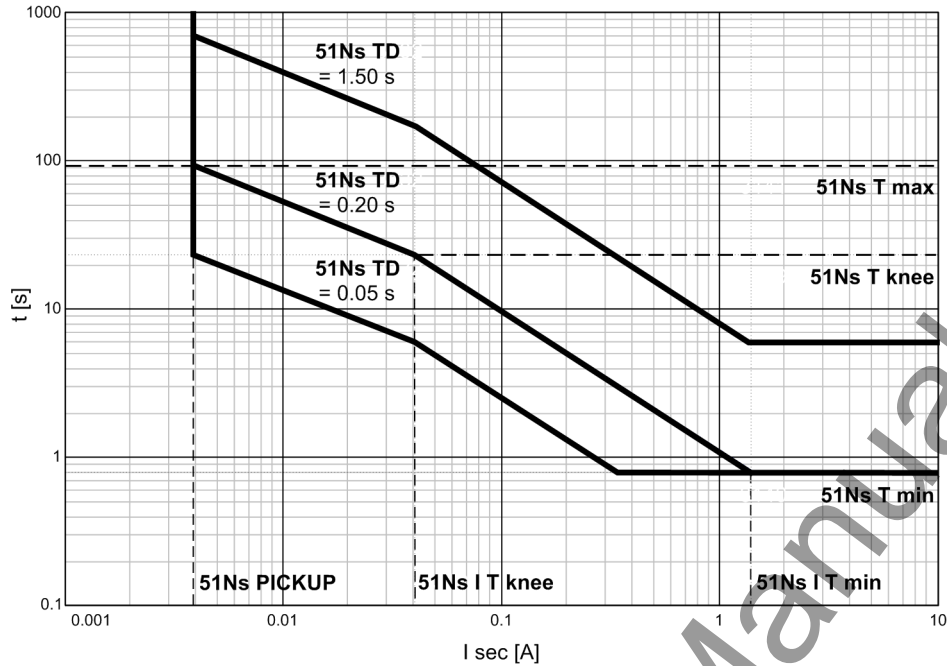

Figure 2-52 Trip-time characteristics of the inverse-time ground fault protection 51Ns with logarithmic inverse characteristic with knee point (example for 51Ns = 0.004 A)

User Defined characteristics (Inverse Time)

If a user-defined characteristic is configured at address 131, **Sens. Gnd Fault User Defined PU**, it should be noted that there is a safety factor of 1.1 between pickup and setting value - as is standard for inverse curves. This means that pickup will only be initiated when current of 1.1 times the setting value flows.

Entry of the value pair (current and time) is a multiple of the settings at addresses 3119 **51Ns PICKUP** and 3120 **51Ns TIME DIAL**. Therefore, it is recommended that these addresses are initially set to 1.00 for simplicity. Once the curve is entered, the settings at addresses 3119 and/or 3120 may be modified if necessary.

The default setting of current values is ∞ . They are, therefore, not enabled — and no pickup or tripping of these protective functions will occur.

Up to 20 pairs of values (current and time) may be entered at address 3131 **M.of PU TD**. The device then approximates the characteristic, using linear interpolation.

The following must be observed:

- The value pairs should be entered in increasing sequence. Fewer than 20 pairs is also sufficient. In most cases, about 10 pairs is sufficient to define the characteristic accurately. A value pair which will not be used has to be made invalid by entering "∞" for the threshold! The user must ensure the value pairs produce a clear and constant characteristic.

The current values entered should be those from Table 2-3, along with the matching times. Deviating values MofPU (multiples of PU-values) are rounded. This, however, will not be indicated.

Currents less than the smallest current value entered will not lead to an extension of the tripping time. The pickup curve (see Figure 2-52) continues, from the smallest current point parallel to the current axis.

Currents greater than the highest current value entered will not lead to a reduction of the tripping time. The pickup curve (see Figure 2-53) continues, from the largest current point parallel to the current axis.

Table 2-7 Preferential values of standardized currents for user-defined tripping curves

MofPU = 1 to 1.94		MofPU = 2 to 4.75		MofPU = 5 to 7.75		MofPU = 8 to 20	
1.00	1.50	2.00	3.50	5.00	6.50	8.00	15.00
1.06	1.56	2.25	3.75	5.25	6.75	9.00	16.00
1.13	1.63	2.50	4.00	5.50	7.00	10.00	17.00
1.19	1.69	2.75	4.25	5.75	7.25	11.00	18.00
1.25	1.75	3.00	4.50	6.00	7.50	12.00	19.00
1.31	1.81	3.25	4.75	6.25	7.75	13.00	20.00
1.38	1.88					14.00	
1.44	1.94						

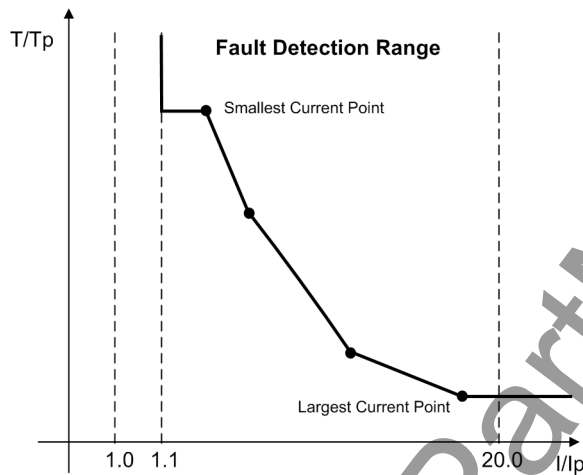

Figure 2-53 Use of a user-defined characteristic

Note Regarding Settings List for Sensitive Ground Fault Detection

In devices with sensitive ground fault input, which is independent of the nominal current rating of the device, settings may in general also be entered as primary values under consideration of the current transformer ratio. However, problems related to the resolution of the pickup currents can occur when very small settings and small nominal primary currents are given. The user is therefore encouraged to enter settings for the sensitive ground fault detection in secondary values.

2.9.4 Settings

Addresses which have an appended "A" can only be changed with DIGSI, under "Display Additional Settings".

The table indicates region-specific default settings. Column C (configuration) indicates the corresponding secondary nominal current of the current transformer.

Addr.	Parameter	C	Setting Options	Default Setting	Comments
3101	Sens. Gnd Fault		OFF ON	OFF	(Sensitive) Ground Fault
3113	50Ns-2 PICKUP		0.001 .. 1.500 A	0.300 A	50Ns-2 Pickup
3113	50Ns-2 PICKUP	1A	0.05 .. 35.00 A	10.00 A	50Ns-2 Pickup
		5A	0.25 .. 175.00 A	50.00 A	
3114	50Ns-2 DELAY		0.00 .. 320.00 sec; ∞	1.00 sec	50Ns-2 Time Delay
3117	50Ns-1 PICKUP		0.001 .. 1.500 A	0.100 A	50Ns-1 Pickup
3117	50Ns-1 PICKUP	1A	0.05 .. 35.00 A	2.00 A	50Ns-1 Pickup
		5A	0.25 .. 175.00 A	10.00 A	
3118	50Ns-1 DELAY		0.00 .. 320.00 sec; ∞	2.00 sec	50Ns-1 Time delay
3119	51Ns PICKUP		0.001 .. 1.400 A	0.100 A	51Ns Pickup
3119	51Ns PICKUP		0.003 .. 0.500 A	0.004 A	51Ns Pickup
3119	51Ns PICKUP	1A	0.05 .. 4.00 A	1.00 A	51Ns Pickup
		5A	0.25 .. 20.00 A	5.00 A	
3120	51NsTIME DIAL		0.10 .. 4.00 sec; ∞	1.00 sec	51Ns Time Dial
3121A	50Ns T DROP-OUT		0.00 .. 60.00 sec	0.00 sec	50Ns Drop-Out Time Delay
3127	51Ns I T min		0.003 .. 1.400 A	1.333 A	51Ns Current at const. Time Delay T min
3127	51Ns I T min	1A	0.05 .. 20.00 A	15.00 A	51Ns Current at const. Time Delay T min
		5A	0.25 .. 100.00 A	75.00 A	
3128	51Ns I T knee		0.003 .. 0.650 A	0.040 A	51Ns Current at Knee Point
3128	51Ns I T knee	1A	0.05 .. 17.00 A	5.00 A	51Ns Current at Knee Point
		5A	0.25 .. 85.00 A	25.00 A	
3129	51Ns T knee		0.20 .. 100.00 sec	23.60 sec	51Ns Time Delay at Knee Point
3131	M.of PU TD		1.00 .. 20.00 MofPU; ∞ 0.01 .. 999.00 TD		Multiples of PU Time-Dial
3132	51Ns TD		0.05 .. 1.50	0.20	51Ns Time Dial
3140	51Ns Tmin		0.00 .. 30.00 sec	1.20 sec	51Ns Minimum Time Delay
3140	51Ns T min		0.10 .. 30.00 sec	0.80 sec	51Ns Minimum Time Delay
3141	51Ns Tmax		0.00 .. 30.00 sec	5.80 sec	51Ns Maximum Time Delay

Addr.	Parameter	C	Setting Options	Default Setting	Comments
3141	51Ns T max		0.50 .. 200.00 sec	93.00 sec	51Ns Maximum Time Delay (at 51Ns PU)
3142	51Ns TIME DIAL		0.05 .. 15.00 sec; ∞	1.35 sec	51Ns Time Dial
3143	51Ns Startpoint		1.0 .. 4.0	1.1	51Ns Start Point of Inverse Charac.

2.9.5 Information List

No.	Information	Type of Information	Comments
1202	>BLOCK 50Ns-2	SP	>BLOCK 50Ns-2
1203	>BLOCK 50Ns-1	SP	>BLOCK 50Ns-1
1204	>BLOCK 51Ns	SP	>BLOCK 51Ns
1207	>BLK 50Ns/67Ns	SP	>BLOCK 50Ns/67Ns
1211	50Ns/67Ns OFF	OUT	50Ns/67Ns is OFF
1212	50Ns/67Ns ACT	OUT	50Ns/67Ns is ACTIVE
1221	50Ns-2 Pickup	OUT	50Ns-2 Pickup
1223	50Ns-2 TRIP	OUT	50Ns-2 TRIP
1224	50Ns-1 Pickup	OUT	50Ns-1 Pickup
1226	50Ns-1 TRIP	OUT	50Ns-1 TRIP
1227	51Ns Pickup	OUT	51Ns picked up
1229	51Ns TRIP	OUT	51Ns TRIP
1230	Sens. Gnd block	OUT	Sensitive ground fault detection BLOCKED
16029	51Ns BLK PaErr	OUT	Sens.gnd.flt. 51Ns BLOCKED Setting Error

2.10 Intermittent Ground Fault Protection

A typical characteristic of intermittent ground faults is that they often disappear automatically to strike again after some time. They can last between a few milliseconds and several seconds. This is why such faults are not detected at all or not selectively by the ordinary time overcurrent protection. If pulse durations are extremely short, not all protection devices in a short-circuit path may pick up; selective tripping is thus not ensured.

Due to the time delay of the overcurrent protection function such faults are too short to initiate shutdown of the faulted cable. Only when they have become permanent such ground faults can be removed selectively by the short-circuit protection.

But such intermittent ground faults already bear the risk of causing thermal damage to equipment. This is why devices 7SJ61 feature a protective function that is able to detect such intermittent ground faults and accumulates their duration. If the sum reaches a configurable value within a certain time, the limit of the thermal load capacity has been reached. If the ground faults are distributed over a long period of time or if the ground fault goes off and does not re-ignite after some time, the equipment under load is expected to cool down. Tripping is not necessary in this case.

Applications

- Protection from intermittent ground faults which occur, e.g. in cables due to poor insulation or water ingress in cable joints.

2.10.1 Description

Acquisition of Measured Quantities

The intermittent ground fault can either be detected via the ordinary ground current input (I_N), the sensitive ground current input (I_{NS}), or it is calculated from the sum of the three phase currents ($3 I_0$). Unlike the overcurrent protection which uses the fundamental wave, the intermittent ground fault protection creates the r.m.s. value of this current and compares it to a settable threshold **Iie>**. This method accounts for higher order harmonics contents (up to 400 Hz) and for the direct component since both factors contribute to the thermal load.

Pickup/Tripping

If the pickup threshold value **Iie>** is exceeded, the pickup message („IIE Fault det“, see Figure 2-54) is issued. The pickups are also counted; as soon as the counter content has reached the value of parameter **Nos.det.**, the message „Intermitt.EF“ is issued. A stabilized pickup is obtained by prolonging the pickup message „IIE Fault det“ by a settable time **T-det.ext.**. This stabilization is especially important for the coordination with existing static or electromechanical overcurrent relays.

The duration of the stabilized pickups „IIE stab.Flt“ is summated with an integrator **T-sum det.**. If the accumulated pickup time reaches a settable threshold value, a corresponding message is generated („IEF Tsum exp.“). Tripping takes place, however, only while a ground fault is present (message „IEF Trip“). The trip command is maintained during the entire minimum tripping time specified for the device, even if the ground fault is of short duration. After completion of the tripping command all memories are reset and the protection resumes normal condition.

The (much longer) resetting time **T-reset** (message „IEF Tres run.“) is launched simultaneously with **T-sum det.** when a ground fault occurs. Unlike **T-sum det.**, each new ground fault resets this time to its initial value and it expires anew. If **T-reset** expires and no new ground fault is recorded during that time, all memories are reset and the protection resumes normal position. **T-reset** thus determines the time during which the next ground fault must occur to be processed yet as intermittent ground fault in connection with the previous fault. A ground fault that occurs later will be considered a new fault event.

The message „IIE Fault det“ will be entered in the fault log and reported to the system interface only until the message „Intermitt.EF“ is issued. This prevents a burst of messages. If the message is allocated to an LED or a relay, this limitation does not apply. This is accomplished by doubling the message (message numbers 6924, 6926).

Interaction with the Automatic Reclosure Function

Automatic reclosure is not an effective measure against intermittent ground faults as the function only trips after repeated detection of a fault or after expiration of the summation monitoring time **T-sum det.** and besides this, its basic design is to prevent thermal overload. For these reasons, the intermittent ground fault protection is not implemented as starting feature of the automatic reclosing function.

Interaction with Breaker Failure Protection

A pickup that is present when the time delay **TRIP-Timer** has expired is interpreted by the breaker failure protection as a criterion for a tripping failure. Since permanent pickup is not ensured after a tripping command by the intermittent ground fault protection, cooperation with the breaker failure protection is not sensible. Therefore, this function is not activated by the intermittent ground fault protection.

Logic Diagram

The following figure shows the logic diagram for the intermittent ground fault protection function.

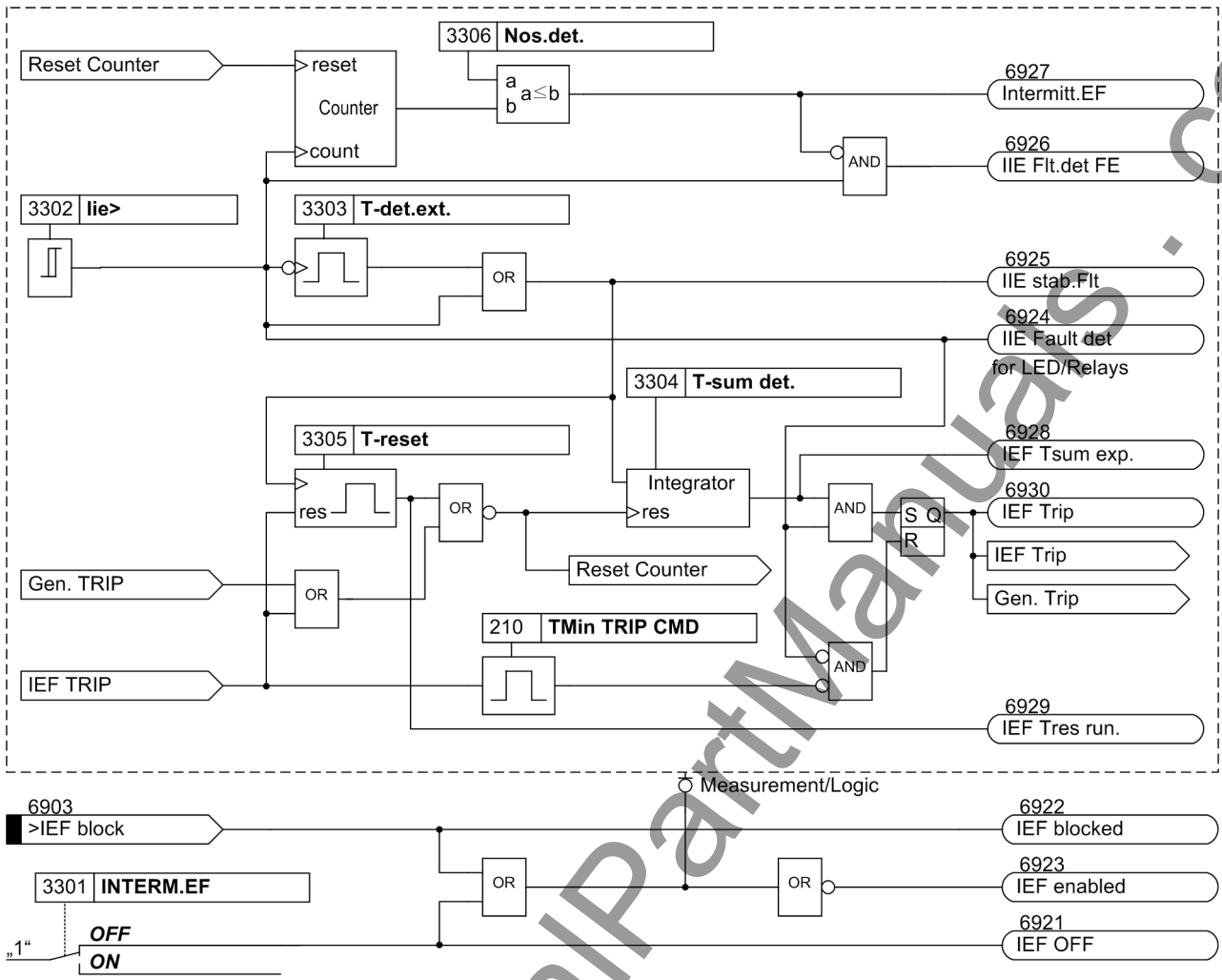

Figure 2-54 Logic diagram of the intermittent ground fault protection – principle

Fault Logging

A fault event and thus fault logging is initiated when the non-stabilized IiE element picks up for the first time. A message „IIE Fault det“ is produced. The message „IIE Fault det“ is issued and entered in the fault log (and reported to the system interface) so often until the number of pickups „IIE Fault det“ has reached the value set for parameter **Nos.det.**. When this happens, the message „Intermitt.EF“ is issued and „IIE Fault det“ is blocked for the fault log and the system interface. This method accounts for the fact that the IiE element may also pick up for a normal short-circuit. In this case the pickup does not launch the alarm „Intermitt.EF“.

Intermittent ground faults may cause other time overcurrent stages to pick up (e.g. 50-1, 50N-1, 50Ns-1) and produce a burst of messages. To avoid overflow of the fault log such messages are not entered anymore in the fault log after detection of an intermittent ground fault (message „Intermitt.EF“) unless they cause a tripping command. If an intermittent ground fault has been detected, the following pickup messages of the time overcurrent protection will still be reported without restraint (see table 2-8):

Table 2-8 Unrestricted messages

FNo.	Message	Explanation
1800	„50-2 picked up“	50-2 picked up
7551	„50-1 InRushPU“	50-1 InRush picked up
7552	„50N-1 InRushPU“	50N-1 InRush picked up
7553	„51 InRushPU“	51 InRush picked up
7554	„51N InRushPU“	51N InRush picked up
7565	„Ia InRush PU“	50/51 phase A InRush picked up
7566	„Ib InRush PU“	50/51 phase B InRush picked up
7567	„Ic InRush PU“	50/51 phase C InRush picked up
7564	„Gnd InRush PU“	Ground InRush picked up

Table 2-9 shows all messages subject to a restraint mechanism avoiding a message burst during an intermittent ground fault:

Table 2-9 Buffered messages

FNo.	Message	Explanation
1761	„50(N)/51(N) PU“	50(N)/51(N) O/C PICKUP
1762	„50/51 Ph A PU“	50/51 phase A picked up
1763	„50/51 Ph B PU“	50/51 phase B picked up
1764	„50/51 Ph C PU“	50/51 phase C picked up
1810	„50-1 picked up“	50-1 picked up
1820	„51 picked up“	51 picked up
1765	„50N/51NPickedup“	50N/51N picked up
1831	„50N-2 picked up“	50N-2 picked up
1834	„50N-1 picked up“	50N-1 picked up
1837	„51N picked up“	51-N picked up
5159	„46-2 picked up“	46-2 picked up
5165	„46-1 picked up“	46-1 picked up
5166	„46-TOC pickedup“	46-TOC picked up
1221	„50Ns-2 Pickup“	50Ns-2 picked up
1224	„50Ns-1 Pickup“	50Ns-1 picked up
1227	„51Ns Pickup“	50Ns picked up
6823	„START-SUP pu“	Startup supervision Pickup

Before they are entered in the fault log (event buffer) and transmitted to the system interface or CFC, the messages of table 2-9 are buffered (starting with the first pickup message received after „Intermitt.EF“ was signalled). The buffering does not apply for signalling to relays and LEDs as it is required by time-graded protection systems for reverse interlocking. The intermediate buffer can store a maximum of two status changes (the most recent ones) for each message.

Buffered messages are signalled to the fault log, CFC and to the system interface with the original time flag only when a TRIP command is initiated by a protective function other than the intermittent ground fault protection. This ascertains that a pickup, although delayed, is always signalled in association with each TRIP command.

All pickup messages, which usually do not occur during an intermittent ground fault, are not affected by this mechanism. This includes the pickup and TRIP commands of the following protective functions:

- Breaker failure protection,
- Thermal Overload Protection.

The pickup signals of these functions will still be logged immediately. A TRIP command of one of these protective functions will cause the buffered messages to be cleared since no connection exists between tripping function and buffered message.

A fault event is cleared when the time **T-reset** has expired or the TRIP command „IEF Trip“ has been terminated.

Terminating a fault event for the intermittent ground fault protection thus is a special case. It is the time **T-reset** that keeps the fault event opened and not the pickup.

2.10.2 Setting Notes

General

The protection function for intermittent ground faults can only take effect and is only accessible if the current to be evaluated (133, **INTERM.EF** or *with Ignd*) was configured in address *with 310 with Ignd, sens..* If not required, this function is set to **Disabled**.

The function can be turned **ON** or **OFF** under address 3301 **INTERM.EF**.

The pickup threshold (r.m.s. value) is set in address 3302 **Iie>**. A rather sensitive setting is possible to respond also to short ground faults since the pickup time shortens as the current in excess of the setting increases. The setting range depends on the selection of the current to be evaluated at address 133 **INTERM.EF**.

The pickup time can be prolonged at address 3303 **T-det.ext..** This pickup stabilization is especially important for the coordination with existing analog or electromechanical overcurrent relays. The time **T-det.ext.** can also be disabled (**T-det.ext.** = 0).

The stabilized pickup starts the counter **T-sum det..** This counter is stopped but not reset when the picked up function drops out. Based on the last counter content the counter resumes counting when the stabilized function picks up next. This sum of individual pickup times, which are to initiate tripping, is set at address 3304 **T-sum det..** It represents one of the four selectivity criteria (pickup value **Iie>**, detection extension time **T-det.ext.**, counter **T-sum det.** and reset time **T-reset**) for coordinating the relays on adjacent feeders and is comparable to the time grading of the time overcurrent protection. The relay in the radial network which is closest to the intermittent fault and picks up, will have the shortest summation time **T-sum det..**

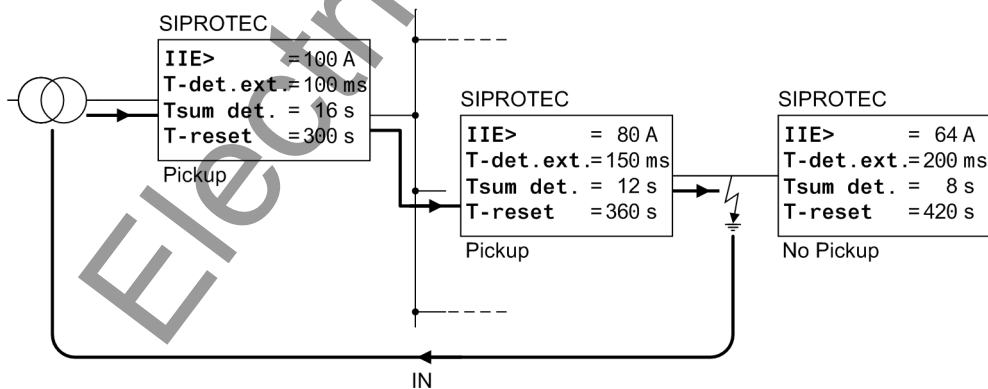

Figure 2-55 Example of selectivity criteria of the intermittent ground fault protection

The reset time, after which the summation is reset in healthy operation and the protection resumes normal status, is configured to **T-reset** at address 3305.

Address 3306 **Nos.det.** specifies the number of pickups after which a ground fault is considered intermittent.

2.10.3 Settings

The table indicates region-specific default settings. Column C (configuration) indicates the corresponding secondary nominal current of the current transformer.

Addr.	Parameter	C	Setting Options	Default Setting	Comments
3301	INTERM.EF		OFF ON	OFF	Intermittent earth fault protection
3302	lie>	1A	0.05 .. 35.00 A	1.00 A	Pick-up value of interm. E/F stage
		5A	0.25 .. 175.00 A	5.00 A	
3302	lie>	1A	0.05 .. 35.00 A	1.00 A	Pick-up value of interm. E/F stage
		5A	0.25 .. 175.00 A	5.00 A	
3302	lie>		0.005 .. 1.500 A	1.000 A	Pick-up value of interm. E/F stage
3303	T-det.ext.		0.00 .. 10.00 sec	0.10 sec	Detection extension time
3304	T-sum det.		0.00 .. 100.00 sec	20.00 sec	Sum of detection times
3305	T-reset		1 .. 600 sec	300 sec	Reset time
3306	Nos.det.		2 .. 10	3	No. of det. for start of int. E/F prot

2.10.4 Information List

No.	Information	Type of Information	Comments
6903	>IEF block	SP	>block interm. E/F prot.
6921	IEF OFF	OUT	Interm. E/F prot. is switched off
6922	IEF blocked	OUT	Interm. E/F prot. is blocked
6923	IEF enabled	OUT	Interm. E/F prot. is active
6924	IIE Fault det	OUT	Interm. E/F detection stage lie>
6925	IIE stab.Flt	OUT	Interm. E/F stab detection
6926	IIE Flt.det FE	OUT	Interm.E/F det.stage lie> f.Flt. ev.Prot
6927	Intermitt.EF	OUT	Interm. E/F detected
6928	IEF Tsum exp.	OUT	Counter of det. times elapsed
6929	IEF Tres run.	OUT	Interm. E/F: reset time running
6930	IEF Trip	OUT	Interm. E/F: trip
6931	lie/In=	VI	Max RMS current value of fault =
6932	Nos.IIE=	VI	No. of detections by stage lie>=

2.11 Automatic Reclosing System 79

From experience, about 85 % of insulation faults associated with overhead lines are arc short circuits which are temporary in nature and disappear when protection takes effect. This means that the line can be connected again. The reconnection is accomplished after a dead time via the automatic reclosing system.

If the fault still exists after automatic reclosure (arc has not disappeared, there is a metallic fault), then the protective elements will re-trip the circuit breaker. In some systems several reclosing attempts are performed.

Applications

- The automatic reclosure system integrated in the 7SJ61 can also be controlled by an external protection device (e.g. backup protection). For this application, an output contact from the tripping relay must be wired to a binary input of the 7SJ61 relay.
- It is also possible to allow the relay 7SJ61 to work in conjunction with an external reclosing device.
- Since the automatic reclosing function is not applied when the 7SJ61 is used to protect generators, motors, transformers, cables and reactors etc., it should be disabled for this application.

2.11.1 Program Execution

The 7SJ61 is equipped with an integrated three-pole, single-shot and multi-shot automatic reclosure (AR). Figure 2-56 shows an example of a timing diagram for a successful second reclosure.

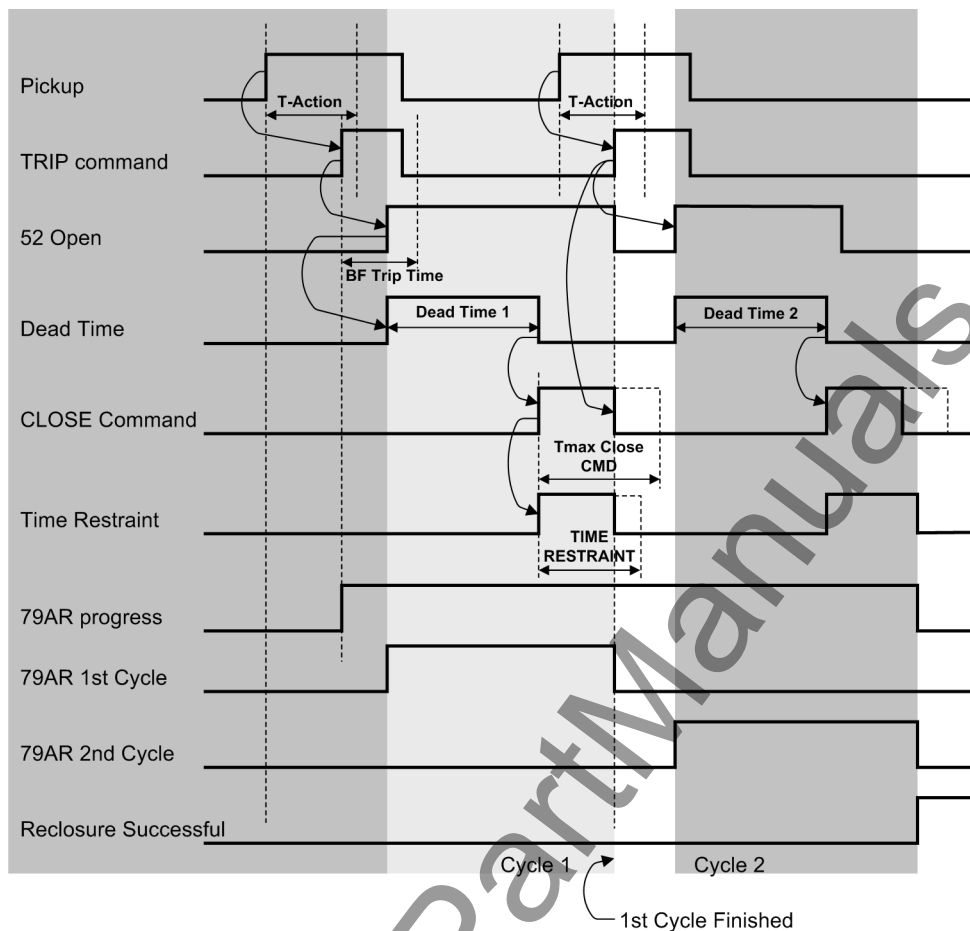

Figure 2-56 Timing diagram showing two reclosing shots, first cycle unsuccessful, second cycle successful

The following figure shows an example of a timing diagram showing for two unsuccessful reclosing shots, with no additional reclosing of the circuit breaker.

The number of reclose commands initiated by the automatic reclosure function are counted. A statistical counter is available for this purpose for the first and all subsequent reclosing commands.

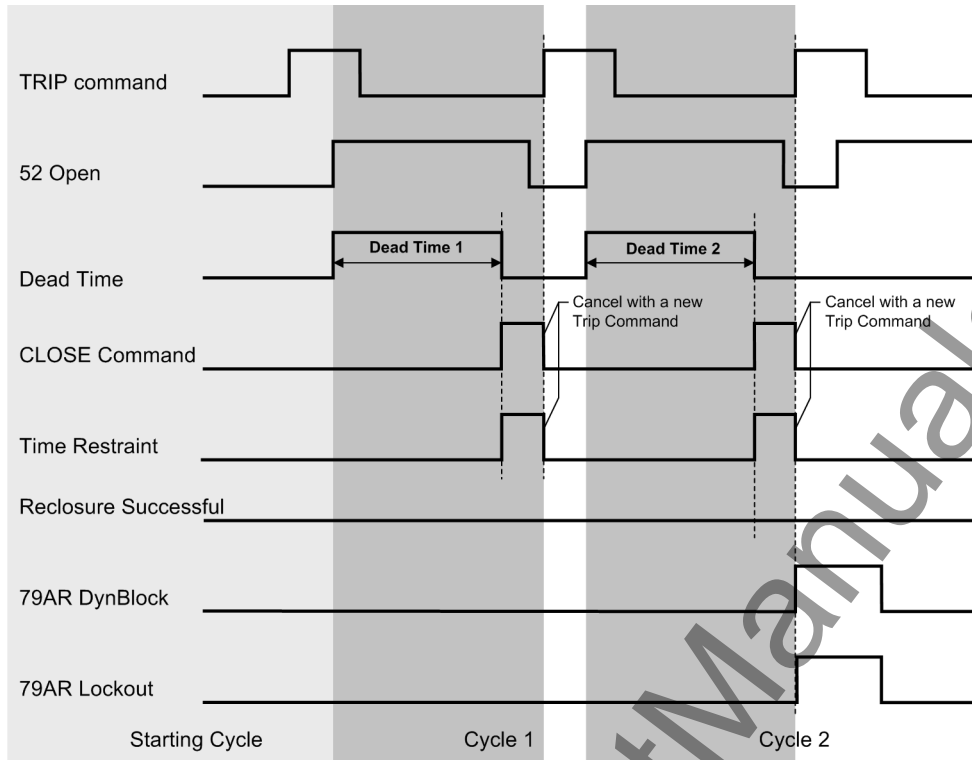

Figure 2-57 Timing diagram showing two unsuccessful reclosing shots

Initiation

Initiation of the automatic reclosing function can be caused by internal protective functions or externally using a binary input. The automatic reclosing system can be programmed such that any of the elements of Table 2-10 can initiate (**Starts 79**), not initiate (**No influence**), or block reclosing (**Stops 79**):

Table 2-10 Initiating automatic reclosure

Start Time Overcurrent Protection	Start Other
50-1	SENS. GROUND FLT (50Ns, 51Ns)
50N-1	46
50-2	BINARY INPUT
50N-2	
50-3	
50N-3	
51	
51N	

On initiation, the automatic reclosure function is informed that a trip command was issued and the respective reclosing program is now being executed.

The binary input messages 2715 „>Start 79 Gnd“ and 2716 „>Start 79 Ph“ for starting an automatic reclosure program can also be activated via CFC (fast PLC task processing). Automatic reclosure can thus be initiated via any messages (e.g. protective pickup) if address 7164 **BINARY INPUT** is set to **Starts 79**.

Action Time

The action time (address 7117) monitors the time between a device pickup and the trip command of a protective function configured as starter. The action time is launched when pickup of any function is detected, which is set as source of the automatic reclosure program. Protection functions which are set to **Alarm Only** or which in principle should not start a reclosing program do not trigger the action time.

If a protective function configured as starter initiates a trip command during the action time, the automatic reclosure program is started. Trip commands of a protective function configured as starter occurring in the time between expiration of the action time and dropout of the device pickup cause the dynamic blocking of the automatic reclosing program. Trip commands of protective functions which are not configured as starter do not affect the action time.

If the automatic reclosure program interacts with an external protection device, the general device pickup for starting the operating time is communicated to the automatic reclosing program via binary input 2711 „>79 Start“.

Delay of Dead Time Start

After start of the auto-reclose function, the dead time start can be delayed by pickup of the binary input message 2754 „>79 DT St.De1ay“. The dead time is not initiated as long as the binary input is active. Start occurs only on cleared binary input. The delay of the dead time start can be monitored via parameter 7118 **T DEAD DELAY**. If the time elapses and the binary input is still active, the **Automatic Reclosing System 79** changes to the status of the dynamic blocking via (2785 „79 DynB1ock“). The maximum time delay of the dead time start is logged by message 2753 „79 DT delay ex.“.

Reclosing Programs

Depending on the type of fault, two different reclosing programs can be used. Here the following applies:

- The single phase fault (**ground** fault) reclosing program applies if all fault protection functions that initiate automatic reclosure detected a phase-to-ground fault. The following conditions must apply: only one phase, only one phase and ground or only ground have picked up. This program can also be started via a binary input.
- The multiple phase fault (**phase** fault) reclosing program applies to all other cases. That is, when elements associated with two or more phases pick up, with or without the pickup of ground elements, such as negative sequence elements. This program can be started via a binary input as well.

The reclosure program evaluates only elements during pick up as elements dropping out may corrupt the result if they drop out at different times when opening the circuit breaker. Therefore, the ground fault reclosure program is executed only when the elements associated with one particular phase pick up until the circuit breaker is opened; all others conditions will initiate the phase fault program.

For each of the programs, up to 9 reclosing attempts can be separately programmed. The first four reclosing attempts can be set differently for each of the two reclosing programs. The fifth and preceding automatic reclosures will correspond to the fourth dead time.

Reclosing Before Selectivity

For the automatic reclosure sequence to be successful, faults on any part of the line must be cleared from the feeding line end(s) within the same – shortest possible – time. Usually, therefore, an instantaneous protection element is set to operate before an automatic reclosure. Fast fault termination has thus priority over selectivity aspects as the reclosing action aims at maintaining normal system operation. For this purpose all protective functions which can initiate the automatic reclosure function are set in such manner that they may trip instantaneously or with a very small time delay before auto-reclosure.

With the final reclosing attempt, i.e. when no automatic reclosing is expected, protection is to trip with delay according to the grading coordination chart of the system, since selectivity has priority. For details see also information at margin heading "Interaction with the Automatic Reclosing Function" which can be found with the

setting notes of the overcurrent protection functions and the functional description of the intermittent ground fault protection.

Single-shot Reclosing

When a trip signal is programmed to initiate the auto-reclosure, the appropriate automatic reclosing program will be executed. Once the circuit breaker has opened, a dead time interval in accordance with the type of fault is started (see also margin heading "Reclosing Programs"). Once the dead time interval has elapsed, a closing signal is issued to reclose the circuit breaker. A blocking time interval **TIME RESTRAINT** is started at the same time. Within this restraint time it is checked whether the automatic reclosure was performed successfully. If a new fault occurs before the restraint time elapses, the automatic reclosing system is dynamically blocked causing the final tripping of the circuit breaker. The dead time can be set individually for each of the two reclosing programs.

Criteria for opening the circuit breaker may either be the auxiliary contacts of the circuit breaker or the dropout of the general device pickup if auxiliary contacts are not configured.

If the fault is cleared (successful reclosing attempt), the blocking time expires and automatic reclosing is reset in anticipation of a future fault. The fault is terminated.

If the fault has not been cleared (unsuccessful reclosing attempt), then a final trip signal is initiated by one or more protective elements.

Multi-shot Reclosing

7SJ61 permits up to 9 reclosings. The number can be set differently for the phase fault reclosing program and the ground fault reclosing program.

The first reclose cycle is, in principle, the same as the single-shot auto-reclosing. If the first reclosing attempt is unsuccessful, this does not result in a final trip, but in a reset of the restraint time interval and start of the next reclose cycle with the next dead time. This can be repeated until the set number of reclosing attempts for the corresponding reclose program has been reached.

The dead time intervals preceding the first four reclosing attempts can be set differently for each of the two reclosing programs. The dead time intervals preceding the fifth reclosing attempts will be equal to the dead time interval that precedes the fourth reclosing attempt.

If one of the reclosing attempts is successful, i.e. the fault disappeared after reclosure, the restraint time expires and the automatic reclosing system is reset. The fault is cleared.

If none of the reclosing attempts is successful, then a final circuit breaker trip (according to the grading coordination chart) will take place after the last allowable reclosing attempt has been performed by the protection function. All reclosing attempts were unsuccessful.

After the final circuit breaker tripping, the automatic reclosing system is dynamically blocked (see below).

Blocking Time

The function of the blocking time has already been described under section "Single-/Multi-Shot Reclosing". The blocking time can be prolonged if the following conditions have been fulfilled.

The time 211 **TMax CLOSE CMD** defines the maximum time during which a close command can apply. If a new trip command occurs before this time has run out, the close command will be aborted. If the time **TMax CLOSE CMD** is set longer than the restraint time **TIME RESTRAINT**, the restraint time will be extended to the remaining close command duration after expiry!

A pickup from a protection function that is set to initiate the automatic reclosing system will also lead to an extension of the blocking time should it occur during this time!

2.11.2 Blocking

Static Blocking

Static blocking means that the automatic reclosing system is not ready to initiate reclosing, and cannot initiate reclosing as long as the blocking signal is present. A corresponding message „79 is NOT ready“ (FNo. 2784) is generated. The static blocking signal is also used internally to block the protection elements that are only supposed to work when reclosing is enabled (see also side title "Reclosing Before Selectivity" further above).

The automatic reclosing system is statically blocked if:

- The signal „>BLOCK 79“ FNo.2703) is present at a binary input, as long as the automatic reclosing system is not initiated (associated message: „>BLOCK 79“),
- The signal „>CB Ready“ (FNo. 2730) indicates that the circuit breaker disappears via the binary input, if the automatic reclosing system is not initiated (associated message: „>CB Ready“),
- The number of allowable reclosing attempts set for both reclosing programs is zero (associated message: „79 no cycle“),
- No protective functions (parameters 7150 to 7163) or binary inputs are set to initiate the automatic reclosing system (associated message: „79 no starter“),
- The circuit breaker position is reported as being "open" and no trip command applies (associated message: „79 BLK: CB open“). This presumes that 7SJ61 is informed of the circuit breaker position via the auxiliary contacts of the circuit breaker.

Dynamic Blocking

Dynamic blocking of the automatic reclosing program occurs in those cases where the reclosing program is active and one of the conditions for blocking is fulfilled. The dynamic blocking is signaled by the message „79 DynBlock“. The dynamic blocking is associated with the configurable blocking time **SAFETY 79 ready**. This blocking time is usually started by a blocking condition that has been fulfilled. After the blocking time has elapsed, the device checks whether or not the blocking condition can be reset. If the blocking condition is still present or if a new blocking condition is fulfilled, the blocking time is restarted. If, however, the blocking condition no longer holds after the blocking time has elapsed, the dynamic blocking will be reset.

Dynamic blocking is initiated if:

- The maximum number of reclosure attempts has been achieved. If a trip command now occurs within the dynamic blocking time, the automatic reclosure program will be blocked dynamically, (indicated by „79 Max. No. Cyc“).
- The protection function has detected a three-phase fault and the device is programmed not to reclose after three-phase faults, (indicated by „79 BLK:3ph p.u.“).
- if the maximum waiting period **T DEAD DELAY** for the delay of the dead time initiation by binary inputs expires without binary input „>79 DT St.DeLay“ having been disabled during this time period.
- The action time has elapsed without a TRIP command being issued. Each TRIP command that occurs after the action time has expired and before the picked-up element drops out, will initiate the dynamic blocking (indicated by „79 Tact expired“).
- A protective function trips which is to block the automatic reclosure function (as configured). This applies irrespective of the status of the automatic reclosure system (started / not started) if a TRIP command of a blocking element occurs (indicated by „79 BLK by trip“).
- The circuit breaker failure function is initiated.
- The circuit breaker does not trip within the configured time **T-Start MONITOR** after a trip command was issued, thus leading to the assumption that the circuit breaker has failed. (The breaker failure monitoring is primarily intended for commissioning purposes. Commissioning safety checks are often conducted with the circuit breaker disconnected. The breaker failure monitoring prevents unexpected reclosing after the circuit breaker has been reconnected, indicated by „79 T-Start Exp“).

- The circuit breaker is not ready after the breaker monitoring time has elapsed, provided that the circuit breaker check has been activated (address 7113 **CHECK CB?** = *Chk each cycle*, indicated by „79 T-CBreadyExp“).
- The circuit breaker is not ready after maximum extension of the dead time **Max. DEAD EXT..** The monitoring of the circuit breaker status and the synchrocheck may cause undesired extension of the dead time. To prevent the automatic reclosure system from assuming an undefined state, the extension of the dead time is monitored. The extension time is started when the regular dead time has elapsed. When it has elapsed, the automatic reclosure function is blocked dynamically and the lock-out time launched. The automatic reclosure system resumes normal state when the lock-out time has elapsed and new blocking conditions do not apply (indicated by „79 TdeadMax Exp“).
- Manual closing has been detected (externally) and parameter **BLOCK MC Dur.** (T = 0) was set such that the automatic reclosing system responds to manual closing,
- Via a correspondingly masked binary input (FNo. 2703 „BLOCK 79“). If the blocking takes place while the automatic recloser is in normal state, the latter will be blocked statically („79 is NOT ready“). The blocking is terminated immediately when the binary input has been cleared and the automatic reclosure function resumes normal state. If the automatic reclosure function is already running when the blocking arrives, the dynamic blocking takes effect („79 DynBlock“). In this case the activation of the binary input starts the dynamic blocking time **SAFETY 79 ready**. Upon its expiration the device checks if the binary input is still activated. If this is the case, the automatic reclosure program changes from dynamic blocking to static blocking. If the binary input is no longer active when the time has elapsed and if no new blocking conditions apply, the automatic reclosure system resumes normal state.

2.11.3 Status Recognition and Monitoring of the Circuit Breaker

Circuit Breaker Status

The detection of the actual circuit breaker status is necessary for the correct functionality of the auto reclose function. The breaker status is detected by the circuit breaker auxiliary contacts and is communicated to the device via binary inputs 4602 „>52 - b“ and 4601 „>52 - a“ .

Here the following applies:

- If binary input 4601 „>52 - a“ and binary input 4602 „>52 - b“ are used, the automatic reclosure function can detect whether the circuit breaker is open, closed or in intermediate position. If both auxiliary contacts detect that the circuit breaker is open, the dead time is started. If the circuit breaker is open or in intermediate position without a trip command being present, the automatic reclosure function is blocked dynamically if it is already running. If the automatic reclosure system is in normal state, it will be blocked statically. When checking whether a trip command applies, all trip commands of the device are taken into account irrespective of whether the function acts as starting or blocking element on behalf of the automatic reclosure program.
- If binary input 4601 „>52 - a“ alone is allocated, the circuit breaker is considered open while the binary input is not active. If the binary input becomes inactive while no trip command of (any) function applies, the automatic reclosure system will be blocked. The blocking will be of static nature if the automatic reclosure system is in normal state at this time. If the automatic reclosing system is already running, the blocking will be a dynamic one. The dead time is started if the binary input becomes inactive following the trip command of a starting element 4601 „>52 - a“ = inactive). An intermediate position of the circuit breaker cannot be detected for this type of allocation.

- If binary input 4602 „>52 - b“ alone is allocated, the circuit breaker is considered open while the binary input is active. If the binary input becomes active while no trip command of (any) function applies, the automatic reclosure system will be blocked dynamically provided it is already running. Otherwise the blocking will be a static one. The dead time is started if the binary input becomes active following the trip command of a starting element. An intermediate position of the circuit breaker cannot be detected for this type of allocation.
- If neither binary input 4602 „>52 - b“ nor 4601 „>52 - a“ are allocated, the automatic reclosure program cannot detect the position of the circuit breaker. In this case, the automatic reclosure system will be controlled exclusively via pickups and trip commands. Monitoring for "52-b without TRIP" and starting the dead time in dependence of the circuit breaker feedback is not possible in this case.

Circuit Breaker Monitoring

The time needed by the circuit breaker to perform a complete reclose cycle can be monitored by the 7SJ61. Breaker failure is detected:

A precondition for a reclosing attempt, following a trip command initiated by a protective relay element and subsequent initiation of the automatic reclosing function, is that the circuit breaker is ready for at least one TRIP-CLOSE-TRIP cycle. The readiness of the circuit breaker is monitored by the device using a binary input „>CB Ready“. In the case where this signal from the breaker is not available, the circuit breaker monitoring feature should be disabled, otherwise reclosing attempts will remain blocked.

- Especially when multiple reclosing attempts are programmed, it is a good idea to monitor the circuit breaker condition not only prior to the first but also to each reclosing attempt. A reclosing attempt will be blocked until the binary input indicates that the circuit breaker is ready to complete another CLOSE-TRIP cycle.
- The time needed by the circuit-breaker to regain the ready state can be monitored by the 7SJ61. The monitoring time **CB TIME OUT** expires for as long as the circuit breaker does not indicate that it is ready via binary input „>CB Ready“ (FNo. 2730). Meaning that as the binary input „>CB Ready“ is cleared, the monitoring time **CB TIME OUT** is started. If the binary input returns before the monitoring time has elapsed, the monitoring time will be cancelled and the reclosure process is continued. If the monitoring time runs longer than the dead time, the dead time will be extended accordingly. If the monitoring time elapses before the circuit breaker signals its readiness, the automatic reclosure function will be blocked dynamically.

Interaction with the synchronism check may cause the dead time to extend inadmissibly. To prevent the automatic reclosure function from remaining in an undefined state, dead time extension is monitored. The maximum extension of the dead time can be set at **Max. DEAD EXT.**. The monitoring time **Max. DEAD EXT.** is started when the regular dead time has elapsed. If the synchronism check responds before the time has elapsed, the monitoring time will be stopped and the close command generated. If the time expires before the synchronism check reacts, the automatic reclosure function will be blocked dynamically.

Please make sure that the above mentioned time is not shorter than the monitoring time **CB TIME OUT**.

The time 7114 **T-Start MONITOR** serves for monitoring the response of the automatic reclosure function to a breaker failure. It is activated by a trip command arriving before or during a reclosing operation and marks the time that passes between tripping and opening of the circuit breaker. If the time elapses, the device assumes a breaker failure and the automatic reclosure function is blocked dynamically. If parameter **T-Start MONITOR** is set to ∞ , the start monitoring is disabled.

2.11.4 Controlling Protection Elements

Depending on the reclosing cycle it is possible to control elements of the directional and non-directional overcurrent protection by means of the automatic reclosure system (Protective Elements Control). There are three mechanisms:

1. Time overcurrent elements may trip instantaneously depending on the automatic reclosure cycle ($T = 0$), they may remain unaffected by the auto reclosing function AR ($T = T$) or may be blocked ($T = \infty$). For further information see side title "Cyclic Control".
2. The automatic reclosing states "Auto Reclosing ready" and "Auto Reclosing not ready" can activate or deactivate the dynamic cold load pickup function. This function is designed to influence overcurrent stages (see also Section 2.11.6 and Section 2.3) regarding thresholds and tripping time delays.
3. The time overcurrent protection parameter 1X14A 50(N)-2 ACTIVE or 1X16A 50(N)-3 ACTIVE defines whether the elements 50(N)-2 or 50(N)-3 are to operate always or only with "79M Auto Reclosing ready"(see Section 2.2).

Cyclic Control

Control of the time overcurrent protection elements takes effect by releasing the cycle marked by the corresponding parameter. The cycle zone release is indicated by the messages „79 1.CycZoneRe1“ to „79 4.CycZoneRe1“. If the automatic reclosure system is in normal state, the settings for the starting cycle apply. These settings always take effect when the automatic reclosure system assumes normal state.

The settings are released for each following cycle when issuing the close command and starting the blocking time. Following a successful reclosure (blocking time expired) or after returning from the blocking, the auto-reclose function goes into normal state. Control of the protection is again assumed by the parameters for the starting cycle.

The following figure illustrates the control of the protection elements 50-2 and 50N-2.

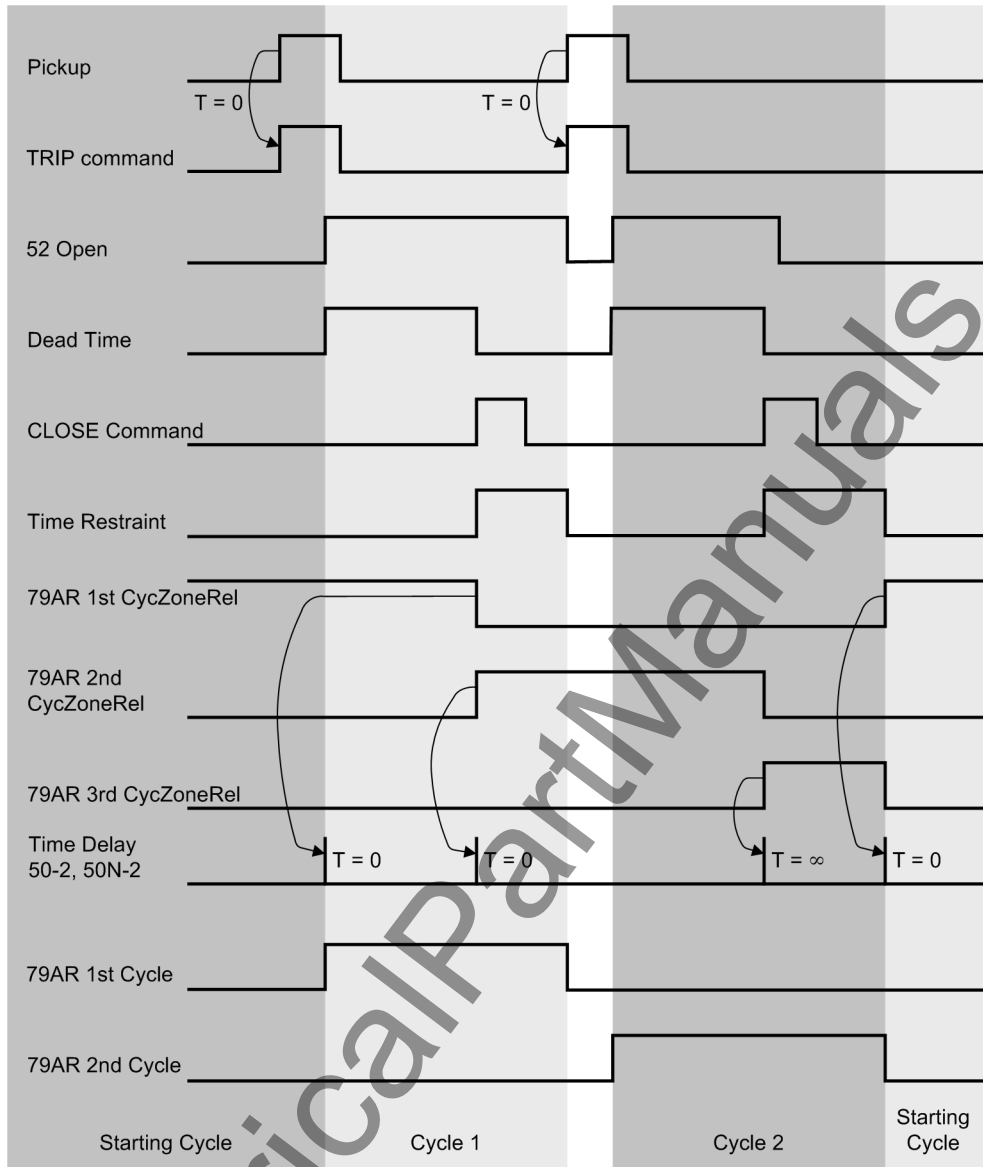

Figure 2-58 Control of protection elements for two-fold, successful auto-reclosure

Example:

Before the first reclosing, faults are to be eliminated quickly applying elements 50-2 or 50N-2. Fast fault termination thus has priority over selectivity aspects as the reclosing action aims at maintaining normal system operation. If the fault prevails, a second tripping is to take place instantaneously and subsequently, a second reclosing.

After the second reclosing, however, elements 50-2 or 50N-2 are to be blocked so the fault can be eliminated by applying elements 50-1 or 50N-1 according to the grading coordination chart of the system giving priority to selectivity concerns.

Addresses 7202 **bef. 1.Cy:50-2**, 7214 **bef. 2.Cy:50-2**, 7203 **bef. 1.Cy:50N-2** and 7215 **bef. 2.Cy:50N-2** are set to **instant**. $T=0$ to enable the elements after the first reclosing. Addresses 7226 **bef. 3.Cy:50-2** and 7227 **bef. 3.Cy:50N-2**, however, are set to **blocked** $T=\infty$, to ensure that elements 50-2 and 50N-2 are blocked when the second reclosing applies. The back-up elements, e.g. 50-1 and 50N-1, must obviously not be blocked (addresses 7200, 7201, 7212, 7213, 7224 and 7225).

The blocking applies only after reclosure in accordance with the set address. Hence, it is possible to specify again other conditions for a third reclosure.

The blocking conditions are also valid for the zone sequence coordination, provided it is available and activated (address 7140, see also margin heading "Zone Sequencing").

2.11.5 Zone Sequencing (not available for models 7SJ6***-**A**-)

It is the task of the zone sequence coordination to harmonize the automatic reclosure function of this device with that of another device that forms part of the same power system. It is a complementary function to the automatic reclosure program and allows, for example, to perform group reclosing operations in radial systems. In case of multiple reclosures, groups may also be in nested arrangement and further high-voltage fuses can be overgraded or undergraded.

Zone sequencing functions by means of blocking certain protection functions depending on the reclosing cycle. This is implemented by the protection elements control (see margin heading "Controlling Protection Elements").

As a special feature, changing from one reclosing cycle to the next is possible without trip command only via pickup/dropout of 50-1 or 50N-1.

The following figure shows an example of a group reclosure at feeder 3. It is assumed that reclosure is performed twice.

With fault F1 on feeder 5, protection devices in the infeed and on feeder 3 pick up. The time delay of the 50-2 element at protecting feeder 3 is set in such a way that the feeder 3 circuit breaker will clear the fault before the fuse at feeder 5 is damaged. If the fault is cleared, all functions are reset after the restraint time has expired and the fault is terminated. The fuse has therefore also been protected.

If the fault continues to exist, a second reclosing cycle is performed in the same way.

High speed element 50-2 is now being blocked at relay protecting Feeder 3. If the fault still remains, only the 50-1 element continues to be active in Feeder 3 which, however, **overgrades** the fuse with a time delay of 0.4 s. After the fuse operated to clear the fault, the series-connected devices drop out. If the fuse fails to clear the fault, then the 50-1 element protecting Feeder 3 will operate as backup protection.

The 50-2 element at the busbar relay is set with a delay of 0.4 seconds, since it supposed to trip the 50-2 elements and the fuses as well. For the second reclosing, the 50-2 element also has to be blocked to give preference to the feeder relay (50-1 element with 0.4 s). For this purpose, the device has to "know" that two reclosing attempts have already been performed.

In this device, zone sequence coordination must be switched off: When pickup of 50-1 or 50N-1 drops out, zone sequence coordination provokes that the reclosing attempts are counted as well. If the fault still persists after the second reclosure, the 50-1 element, which is set to 0.9 seconds, would serve as backup protection.

For the busbar fault F2, the 50-2 element at the bus would have cleared the fault in 0.4 seconds. Zone sequencing enables the user to set a relatively short time period for the 50-2 elements. The 50-2 element is only used as backup protection. If zone sequencing is not applied, the 50-1 element is to be used only with its relatively long time period (0.9 s).

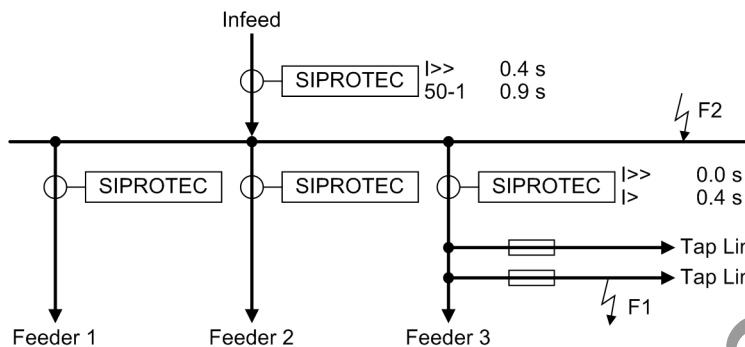

Figure 2-59 Zone sequencing with a fault occurring at Tap Line #5 and the busbar

2.11.6 Setting Notes

General Settings

The internal automatic reclosure system will only be effective and accessible if address 171 79 **Auto Recl.** is set **Enabled** during configuration. If not required, this function is set to **Disabled**. The function can be turned **ON** or **OFF** under address 7101 **FCT 79**.

If no automatic reclosures are performed on the feeder for which the 7SJ61 is used (e.g. cables, transformers, motors, etc.), the automatic reclosure function is disabled by configuration. The automatic reclosure function is then completely disabled, i.e. the automatic reclosure function is not processed in the 7SJ61. No messages exist for this purpose and binary inputs for the automatic reclosure function are ignored. All parameters of block 71 are inaccessible and of no significance.

Blocking Duration for Manual-CLOSE Detection

Parameter 7103 **BLOCK MC Dur.** defines the reaction of the automatic reclosure function when a manual closing signal is detected. The parameter can be set to specify how long the auto reclose function will be blocked dynamically in case of an external manual close-command being detected via binary input (356 „>Manual Close“). If the setting is 0, the automatic reclosure system will not respond to a manual close-signal.

Restraint Time and Dynamic Blocking

The blocking time **TIME RESTRAINT** (address 7105) defines the time that must elapse, after a successful reclosing attempt, before the automatic reclosing function is reset. If a protective function configured for initiation of the auto-reclosure function provokes a new trip before this time elapses, the next reclosing cycle is started in case of multiple reclosures. If no further reclosure is allowed, the last reclosure will be classed as unsuccessful.

In general, a few seconds are sufficient. In areas with frequent thunderstorms or storms, a shorter blocking time may be necessary to avoid feeder lockout due to sequential lightning strikes or flashovers.

A longer restraint time should be chosen if there is no possibility to monitor the circuit breaker (see below) during multiple reclosing (e.g. because of missing auxiliary contacts and information on the circuit breaker ready status). In this case, the restraint time should be longer than the time required for the circuit breaker mechanism to be ready.

If a dynamic blocking of the automatic reclosing system was initiated, then reclosing functions remain blocked until the cause of the blocking has been cleared. The functional description gives further information on this topic, see marginal heading "Dynamic Blocking". The dynamic blocking is associated with the configurable blocking time **SAFETY 79 ready**. Dynamic blocking time is usually started by a blocking condition that has picked up.

Circuit Breaker Monitoring

Reclosing after a fault tripping presupposes that the circuit breaker is ready for at least one TRIP-CLOSE-TRIP cycle at the time when the reclosing function is initiated (i.e. at the beginning of a trip command):

The readiness of the circuit breaker is monitored by the device using a binary input „>CB Ready“ (FNo. 2730).

- It is possible to check the status of the circuit breaker before each reclosure or to disable this option (address 7113, **CHECK CB?**):

CHECK CB? = No check, deactivates the circuit breaker check,

CHECK CB? = Chk each cycle, to verify the circuit breaker status before each reclosing command.

Checking the status of the circuit breaker is usually recommended. Should the breaker not provide such a signal, you can disable the circuit breaker check at address 7113 **CHECK CB? (No check)**, as otherwise auto-reclosure would be impossible.

The status monitoring time **CB TIME OUT** can be configured at address 7115 if the circuit breaker check was enabled at address 7113. This time is set slightly higher than the maximum recovery time of the circuit breaker following reclosure. If the circuit breaker is not ready after the time has expired, reclosing is omitted and dynamic blocking is initiated. Automatic reclosure thus is blocked.

Time **Max. DEAD EXT.** serves for monitoring the dead time extension. The extension can be initiated by the circuit breaker monitoring time **CB TIME OUT** and by an external synchronism check.

The monitoring time **Max. DEAD EXT.** is started after the configured dead time has elapsed.

This time must not be shorter than **CB TIME OUT**. When using the monitoring time **CB TIME OUT**, the time **Max. DEAD EXT.** should be set to a value \geq **CB TIME OUT**.

If the auto-reclose system is operated with a synchronization function (internal or external), **Max. DEAD EXT.** assures that the auto-reclose system does not remain in undefined state when the synchronism check fails to check back.

If the synchronization is used as synchronism check (for synchronous systems), the monitoring time may be configured quite short, e.g. to some seconds. In this case the synchronizing function merely checks the synchronism of the power systems. If synchronism prevails it switches in instantaneously, otherwise it will not.

If external synchronization is used for synchronous/asynchronous networks, the monitoring time must grant sufficient time for determining the time for switching in. This depends on the frequency slip of the two subnetworks. A monitoring time of 100 s should be sufficient to account for most applications for asynchronous networks.

Generally, the monitoring time should be longer than the maximum duration of the synchronization process (parameter 6x12).

The breaker failure monitoring time 7114 **T-Start MONITOR** determines the time between tripping (closing the trip contact) and opening the circuit breaker (checkback of the CB auxiliary contacts or disappearing device pickup if no auxiliary contacts are allocated). This time is started each time a tripping operation takes place. When time has elapsed, the device assumes breaker failure and blocks the auto-reclose system dynamically.

Action Time

The action time monitors the time between pickup of the device and trip command of a protective function configured as starter while the automatic reclosing system is ready but not yet running. A trip command issued by a protective function configured as starter occurring within the action time will start the automatic reclosing function. If this time differs from the setting value of **T-ACTION** (address 7117), the automatic reclosing system will be blocked dynamically. The trip time of inverse tripping characteristics is considerably determined by the fault location or fault resistance. The action time prevents reclosing in case of far remote or high-resistance faults with long tripping time. Trip commands of protective functions which are not configured as starter do not affect the action time.

Delay of Dead Time Start

The dead time start can be delayed by pickup of the binary input message 2754 „>79 DT St.Delay“. The maximum time for this can be parameterized under 7118 **T DEAD DELAY**. The binary input message must be deactivated again within this time in order to start the dead time. The exact sequence is described in the functional description at margin heading "Delay of Dead Time Start".

Number of Reclosing Attempts

The number of reclosing attempts can be set separately for the "phase program" (address 7136 # **OF RECL. PH**) and "ground program" (address 7135 # **OF RECL. GND**). The exact definition of the programs is described in the functional description at margin heading "Reclosing Programs".

Close Command: Direct or via Control

Address 7137 **Cmd.via control** can be set to either generate directly the close command via the automatic reclosing function (setting **Cmd.via control = none**) or have the closing initiated by the control function.

If the automatic reclosing system is to be close via the control function, the Manual Close command has to be suppressed during an automatic reclose command. The example in the section 2.2.10 of a MANUAL CLOSE for commands via the integrated control function has to be extended in this case (see Figure 2-60). The messages 2878 „79 L-N Sequence“ and 2879 „79 L-L Sequence“ indicate that the AR has been started and wants to carry out a reclosure after the dead time. The annunciations set the flipflop and suspend the manual signal until the AR has finished the reclosure attempts. The flipflop is reset via the OR-combination of the annunciations 2784 „79 is NOT ready“, 2785 „79 DynBlock“ and 2862 „79 Successful“. Manual closing is initiated if a CLOSE command comes from the control function.

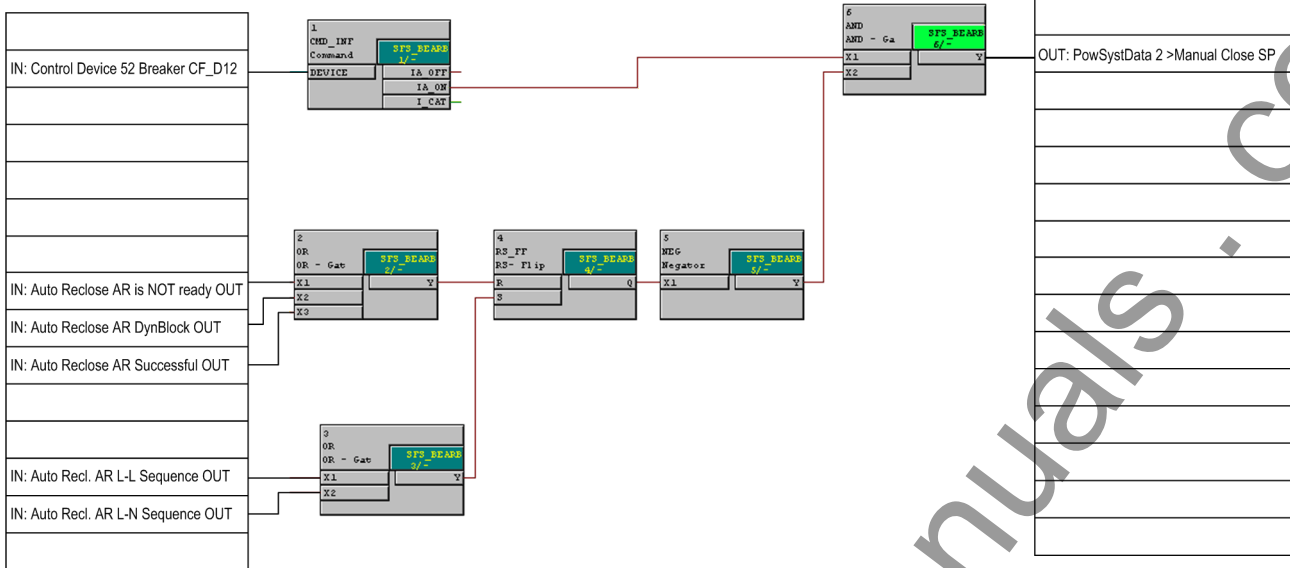

Figure 2-60 CFC logic for Manual Close with automatic reclosing via control

The selection list for parameter 7137 is created dynamically depending on the allocated switchgear components. If one of the switchgear components is selected, usually the circuit breaker „52Breaker“, reclosure is accomplished via control. In this case, the automatic reclosure function does not create a close command but issues a close request. It is forwarded to the control which then takes over the switching. Thus, the properties defined for the switchgear component such as interlocking and command times apply. Hence, it is possible that the close command will not be carried out due to an applying interlocking condition.

If this behavior is not desired, the auto-reclose function can also generate the close command „79 Close“ directly which must be allocated to the associated contact. The CFC Chart as in Figure 2-60 is not needed in this case.

Auto-Reclosing with External Synchrocheck

Parameter 7139 **External SYNC** can be set to determine that the auto-reclose function operates with external synchrocheck. External synchronization is possible if the parameter is set to **YES** and 7SJ61 is linked to the external synchrocheck via the message 2865 „79 Sync . Request“ and the binary input „>Sync . release“.

Initiation and Blocking of Automatic Reclosure by Protective Elements (configuration)

At addresses 7150 to 7167, reclosing can be initiated or blocked for various types of protection functions. They constitute the interconnection between protection elements and auto-reclose function. Each address designates a protection function together with its ANSI synonym, e.g. **50-2** for the high-set element of the non-directional time overcurrent protection (address 7152).

The setting options have the following meaning:

- **Starts 79** The protective element initiates the automatic reclosure via its trip command;
 - No influence** the protective element does not start the automatic reclosure, it may however be initiated by other functions;
 - Stops 79** the protective element blocks the automatic reclosure, it cannot be started by other functions; a dynamic blocking is initiated.

Dead Times (1st AR)

Addresses 7127 and 7128 are used to determine the duration of the dead times of the 1st cycle. The time defined by this parameter is started when the circuit breaker opens (if auxiliary contacts are allocated) or when the pickup drops out following the trip command of a starter. Dead time before first auto-reclosure for reclosing program "Phase" is set in address 7127 **DEADTIME 1: PH**, for reclosing program "ground" in address 7128 **DEADTIME 1: G**. The exact definition of the programs is described in the functional description at margin heading "Reclosing Programs". The length of the dead time should relate to the type of application. With longer lines they should be long enough to make sure that the fault arc disappears and that the air surrounding it is de-ionized and auto-reclosure can successfully take place (usually 0.9 s to 1.5 s). For lines supplied by more than one side, mostly system stability has priority. Since the de-energized line cannot transfer synchronizing energy, only short dead times are allowed. Standard values are 0.3 s to 0.6 s. In radial systems longer dead times are allowed.

Cyclic Control of Protective Functions via Automatic Reclosure

Addresses 7200 to 7205 as well as 7248 and 7249 allow cyclic control of the various protection functions by the automatic reclosing function. Thus protective elements can be blocked selectively, made to operate instantaneously or according to the configured delay times. The following options are available:

The following options are available:

- **Set value $T=T$** The protective element is delayed as configured i.e., the auto-reclose function does not effect this element;
- **instant. $T=0$** The protective element becomes instantaneous if the auto-reclose function is ready to perform the mentioned cycle;
- **blocked $T=\infty$** The protective element is blocked if the auto-reclose function reaches the cycle defined in the parameter.

Dead Times (2nd to 4th AR)

If more than one reclosing cycle was set, you can now configure the individual reclosing settings for the 2nd to 4th cycle. The same options are available as for the first cycle.

For the 2nd cycle:

Address 7129	DEADTIME 2: PH	Dead time for the 2nd reclosing attempt "Phase"
Address 7130	DEADTIME 2: G	Dead time for the 2nd reclosing attempt "Ground"
Addresses 7212 to 7217		allow cyclic control of the various protective functions by the 2nd reclosing attempt

For the 3rd cycle:

Address 7131	DEADTIME 3: PH	Dead time for the 3rd reclosing attempt "Phase"
Address 7132	DEADTIME 3: G	Dead time for the 3rd reclosing attempt "Ground"
Addresses 7224 to 7229		allow cyclic control of the various protective functions by the 3rd reclosing attempt

For the 4th cycle:

Address 7133	DEADTIME 4: PH	Dead time for the 4th reclosing attempt "Phase"
Address 7134	DEADTIME 4: G	Dead time for the 4th reclosing attempt "Ground"
Addresses 7236 to 7241		allow cyclic control of the various protective functions by the 4th reclosing attempt

Fifth to Ninth Reclosing Attempt

If more than four cycles are configured, the dead times set for the fourth cycle also apply to the fifth through to ninth cycle.

Blocking Three-Phase Faults

Regardless of which reclosing program is executed, automatic reclosing can be blocked for trips following three-phase faults (address 7165 **3Po1.PICKUP BLK**). The pickup of all three phases for a specific overcurrent element is the criterion required.

Blocking of Automatic Rreclosure via Internal Control

The auto-reclose function can be blocked, if control commands are issued via the integrated control function of the device. The information must be routed via CFC (interlocking task-level) using the CMD_Information function block (see the following figure).

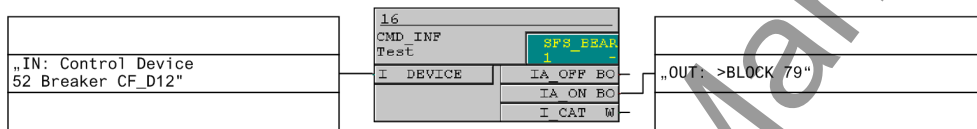

Figure 2-61 Blocking of the automatic reclose function using the internal control function

Zone Sequencing

Not available for models 7SJ61-**A**-**

At address 7140 **ZONE SEQ.COORD.**, the zone sequencing feature can be turned **ON** or **OFF**.

If multiple reclosures are performed and the zone sequencing function is deactivated, only those reclosing cycles are counted which the device has conducted after a trip command. With the zone sequencing function switched on, an additional sequence counter also counts such auto-reclosures which (in radial systems) are carried out by relays connected on load side. This presupposes that the pickup of the 50-1/50N-1 elements drops out without a trip command being issued by a protective function initiating the auto-reclose function. The parameters at addresses 7200 through 7241 (see paragraph below at "Initiation and Blocking of Reclosing by Protective Functions" and "Controlling Overcurrent Protection Stages via Cold Load Pickup") can thus be set to determine which protective elements are active or blocked during what dead time cycles (for multiple reclosing attempts carried out by relays on the load side).

In the example shown in Figure "Zone sequencing with a fault occurring at Tap Line 5 and the busbar" (see Figure) in the functional description, the zone sequencing was applied in the bus relay. Furthermore, as from the second auto-reclosure the 50-2 elements (also applicable to the 50-3 elements) must be blocked, i.e. address 7214 **bef. 2.Cy:50-2** must be set to **blocked T=∞**. The zone sequencing of the feeder relays is switched off but the 50-2 elements must also be blocked after the second reclosing attempt. Moreover, it must be ensured that the 50-2 elements start the automatic reclosing function: Set address 7152 **50-2** to **Starts 79**.

Controlling Overcurrent Protection Stages via Cold Load Pickup

The cold load pickup function is another possibility to control the protection behavior via the automatic reclosing system (see also Section 2.3). This function contains the parameter 1702 **Start Condition** It determines the starting conditions for the increased pickup values of current and time of the cold load pickup to apply for overcurrent protection.

If address 1702 **Start Condition = 79 ready**, the overcurrent protection always employs the increased setting values if the automatic reclosing system is ready. The auto-reclosure function provides the signal **79 ready** for controlling the cold load pickup. The signal **79 ready** is always active if the auto-reclosing system is available, active, unblocked and ready for another cycle. Control via the cold load pickup function is not AR-cycle-related.

Since control via cold load pickup and cyclic control via auto-reclosing system can run simultaneously, the overcurrent protection must coordinate the input values of the two interfaces. In this context the cyclic auto-reclosing control has the priority and thus overwrites the release of the cold load pickup function.

If the protective elements are controlled via the automatic reclosing function, changing the control variables (e.g. by blocking) has no effect on elements that are already running. The elements in question are continued.

Note Regarding Settings List for Automatic Reclosing Function

The setting options of address 7137 **Cmd.via control** are generated dynamically according to the current configuration.

2.11.7 Settings

Addr.	Parameter	Setting Options	Default Setting	Comments
7101	FCT 79	OFF ON	OFF	79 Auto-Reclose Function
7103	BLOCK MC Dur.	0.50 .. 320.00 sec; 0	1.00 sec	AR blocking duration after manual close
7105	TIME RESTRAINT	0.50 .. 320.00 sec	3.00 sec	79 Auto Reclosing reset time
7108	SAFETY 79 ready	0.01 .. 320.00 sec	0.50 sec	Safety Time until 79 is ready
7113	CHECK CB?	No check Chk each cycle	No check	Check circuit breaker before AR?
7114	T-Start MONITOR	0.01 .. 320.00 sec; ∞	0.50 sec	AR start-signal monitoring time
7115	CB TIME OUT	0.10 .. 320.00 sec	3.00 sec	Circuit Breaker (CB) Supervision Time
7116	Max. DEAD EXT.	0.50 .. 1800.00 sec; ∞	100.00 sec	Maximum dead time extension
7117	T-ACTION	0.01 .. 320.00 sec; ∞	∞ sec	Action time
7118	T DEAD DELAY	0.0 .. 1800.0 sec; ∞	1.0 sec	Maximum Time Delay of Dead-Time Start
7127	DEADTIME 1: PH	0.01 .. 320.00 sec	0.50 sec	Dead Time 1: Phase Fault
7128	DEADTIME 1: G	0.01 .. 320.00 sec	0.50 sec	Dead Time 1: Ground Fault
7129	DEADTIME 2: PH	0.01 .. 320.00 sec	0.50 sec	Dead Time 2: Phase Fault
7130	DEADTIME 2: G	0.01 .. 320.00 sec	0.50 sec	Dead Time 2: Ground Fault
7131	DEADTIME 3: PH	0.01 .. 320.00 sec	0.50 sec	Dead Time 3: Phase Fault
7132	DEADTIME 3: G	0.01 .. 320.00 sec	0.50 sec	Dead Time 3: Ground Fault
7133	DEADTIME 4: PH	0.01 .. 320.00 sec	0.50 sec	Dead Time 4: Phase Fault
7134	DEADTIME 4: G	0.01 .. 320.00 sec	0.50 sec	Dead Time 4: Ground Fault
7135	# OF RECL. GND	0 .. 9	1	Number of Reclosing Cycles Ground
7136	# OF RECL. PH	0 .. 9	1	Number of Reclosing Cycles Phase
7137	Cmd.via control	(Setting options depend on configuration)	None	Close command via control device
7139	External SYNC	YES NO	NO	External 25 synchronisation
7140	ZONE SEQ.COORD.	OFF ON	OFF	ZSC - Zone sequence coordination
7150	50-1	No influence Starts 79 Stops 79	No influence	50-1
7151	50N-1	No influence Starts 79 Stops 79	No influence	50N-1
7152	50-2	No influence Starts 79 Stops 79	No influence	50-2

Addr.	Parameter	Setting Options	Default Setting	Comments
7153	50N-2	No influence Starts 79 Stops 79	No influence	50N-2
7154	51	No influence Starts 79 Stops 79	No influence	51
7155	51N	No influence Starts 79 Stops 79	No influence	51N
7162	sens Ground Fit	No influence Starts 79 Stops 79	No influence	(Sensitive) Ground Fault
7163	46	No influence Starts 79 Stops 79	No influence	46
7164	BINARY INPUT	No influence Starts 79 Stops 79	No influence	Binary Input
7165	3Pol.PICKUP BLK	YES NO	NO	3 Pole Pickup blocks 79
7166	50-3	No influence Starts 79 Stops 79	No influence	50-3
7167	50N-3	No influence Starts 79 Stops 79	No influence	50N-3
7200	bef.1.Cy:50-1	Set value T=T instant. T=0 blocked T= ∞	Set value T=T	before 1. Cycle: 50-1
7201	bef.1.Cy:50N-1	Set value T=T instant. T=0 blocked T= ∞	Set value T=T	before 1. Cycle: 50N-1
7202	bef.1.Cy:50-2	Set value T=T instant. T=0 blocked T= ∞	Set value T=T	before 1. Cycle: 50-2
7203	bef.1.Cy:50N-2	Set value T=T instant. T=0 blocked T= ∞	Set value T=T	before 1. Cycle: 50N-2
7204	bef.1.Cy:51	Set value T=T instant. T=0 blocked T= ∞	Set value T=T	before 1. Cycle: 51
7205	bef.1.Cy:51N	Set value T=T instant. T=0 blocked T= ∞	Set value T=T	before 1. Cycle: 51N
7212	bef.2.Cy:50-1	Set value T=T instant. T=0 blocked T= ∞	Set value T=T	before 2. Cycle: 50-1
7213	bef.2.Cy:50N-1	Set value T=T instant. T=0 blocked T= ∞	Set value T=T	before 2. Cycle: 50N-1

Addr.	Parameter	Setting Options	Default Setting	Comments
7214	bef.2.Cy:50-2	Set value T=T instant. T=0 blocked T= ∞	Set value T=T	before 2. Cycle: 50-2
7215	bef.2.Cy:50N-2	Set value T=T instant. T=0 blocked T= ∞	Set value T=T	before 2. Cycle: 50N-2
7216	bef.2.Cy:51	Set value T=T instant. T=0 blocked T= ∞	Set value T=T	before 2. Cycle: 51
7217	bef.2.Cy:51N	Set value T=T instant. T=0 blocked T= ∞	Set value T=T	before 2. Cycle: 51N
7224	bef.3.Cy:50-1	Set value T=T instant. T=0 blocked T= ∞	Set value T=T	before 3. Cycle: 50-1
7225	bef.3.Cy:50N-1	Set value T=T instant. T=0 blocked T= ∞	Set value T=T	before 3. Cycle: 50N-1
7226	bef.3.Cy:50-2	Set value T=T instant. T=0 blocked T= ∞	Set value T=T	before 3. Cycle: 50-2
7227	bef.3.Cy:50N-2	Set value T=T instant. T=0 blocked T= ∞	Set value T=T	before 3. Cycle: 50N-2
7228	bef.3.Cy:51	Set value T=T instant. T=0 blocked T= ∞	Set value T=T	before 3. Cycle: 51
7229	bef.3.Cy:51N	Set value T=T instant. T=0 blocked T= ∞	Set value T=T	before 3. Cycle: 51N
7236	bef.4.Cy:50-1	Set value T=T instant. T=0 blocked T= ∞	Set value T=T	before 4. Cycle: 50-1
7237	bef.4.Cy:50N-1	Set value T=T instant. T=0 blocked T= ∞	Set value T=T	before 4. Cycle: 50N-1
7238	bef.4.Cy:50-2	Set value T=T instant. T=0 blocked T= ∞	Set value T=T	before 4. Cycle: 50-2
7239	bef.4.Cy:50N-2	Set value T=T instant. T=0 blocked T= ∞	Set value T=T	before 4. Cycle: 50N-2
7240	bef.4.Cy:51	Set value T=T instant. T=0 blocked T= ∞	Set value T=T	before 4. Cycle: 51
7241	bef.4.Cy:51N	Set value T=T instant. T=0 blocked T= ∞	Set value T=T	before 4. Cycle: 51N

Addr.	Parameter	Setting Options	Default Setting	Comments
7248	bef.1.Cy:50-3	Set value T=T instant. T=0 blocked T= ∞	Set value T=T	before 1. Cycle: 50-3
7249	bef.1.Cy:50N-3	Set value T=T instant. T=0 blocked T= ∞	Set value T=T	before 1. Cycle: 50N-3
7250	bef.2.Cy:50-3	Set value T=T instant. T=0 blocked T= ∞	Set value T=T	before 2. Cycle: 50-3
7251	bef.2.Cy:50N-3	Set value T=T instant. T=0 blocked T= ∞	Set value T=T	before 2. Cycle: 50N-3
7252	bef.3.Cy:50-3	Set value T=T instant. T=0 blocked T= ∞	Set value T=T	before 3. Cycle: 50-3
7253	bef.3.Cy:50N-3	Set value T=T instant. T=0 blocked T= ∞	Set value T=T	before 3. Cycle: 50N-3
7254	bef.4.Cy:50-3	Set value T=T instant. T=0 blocked T= ∞	Set value T=T	before 4. Cycle: 50-3
7255	bef.4.Cy:50N-3	Set value T=T instant. T=0 blocked T= ∞	Set value T=T	before 4. Cycle: 50N-3

2.11.8 Information List

No.	Information	Type of Information	Comments
127	79 ON/OFF	IntSP	79 ON/OFF (via system port)
2701	>79 ON	SP	>79 ON
2702	>79 OFF	SP	>79 OFF
2703	>BLOCK 79	SP	>BLOCK 79
2711	>79 Start	SP	>79 External start of internal A/R
2715	>Start 79 Gnd	SP	>Start 79 Ground program
2716	>Start 79 Ph	SP	>Start 79 Phase program
2722	>ZSC ON	SP	>Switch zone sequence coordination ON
2723	>ZSC OFF	SP	>Switch zone sequence coordination OFF
2730	>CB Ready	SP	>Circuit breaker READY for reclosing
2731	>Sync.release	SP	>79: Sync. release from ext. sync.-check
2753	79 DT delay ex.	OUT	79: Max. Dead Time Start Delay expired
2754	>79 DT St.Delay	SP	>79: Dead Time Start Delay
2781	79 OFF	OUT	79 Auto recloser is switched OFF
2782	79 ON	IntSP	79 Auto recloser is switched ON
2784	79 is NOT ready	OUT	79 Auto recloser is NOT ready
2785	79 DynBlock	OUT	79 - Auto-reclose is dynamically BLOCKED
2788	79 T-CBreadyExp	OUT	79: CB ready monitoring window expired

No.	Information	Type of Information	Comments
2801	79 in progress	OUT	79 - in progress
2808	79 BLK: CB open	OUT	79: CB open with no trip
2809	79 T-Start Exp	OUT	79: Start-signal monitoring time expired
2810	79 TdeadMax Exp	OUT	79: Maximum dead time expired
2823	79 no starter	OUT	79: no starter configured
2824	79 no cycle	OUT	79: no cycle configured
2827	79 BLK by trip	OUT	79: blocking due to trip
2828	79 BLK:3ph p.u.	OUT	79: blocking due to 3-phase pickup
2829	79 Tact expired	OUT	79: action time expired before trip
2830	79 Max. No. Cyc	OUT	79: max. no. of cycles exceeded
2844	79 1stCyc. run.	OUT	79 1st cycle running
2845	79 2ndCyc. run.	OUT	79 2nd cycle running
2846	79 3rdCyc. run.	OUT	79 3rd cycle running
2847	79 4thCyc. run.	OUT	79 4th or higher cycle running
2851	79 Close	OUT	79 - Close command
2862	79 Successful	OUT	79 - cycle successful
2863	79 Lockout	OUT	79 - Lockout
2865	79 Sync.Request	OUT	79: Synchro-check request
2878	79 L-N Sequence	OUT	79-A/R single phase reclosing sequence
2879	79 L-L Sequence	OUT	79-A/R multi-phase reclosing sequence
2883	ZSC active	OUT	Zone Sequencing is active
2884	ZSC ON	OUT	Zone sequence coordination switched ON
2885	ZSC OFF	OUT	Zone sequence coordination switched OFF
2889	79 1.CycZoneRel	OUT	79 1st cycle zone extension release
2890	79 2.CycZoneRel	OUT	79 2nd cycle zone extension release
2891	79 3.CycZoneRel	OUT	79 3rd cycle zone extension release
2892	79 4.CycZoneRel	OUT	79 4th cycle zone extension release
2899	79 CloseRequest	OUT	79: Close request to Control Function

2.12 Breaker Failure Protection 50BF

The breaker failure protection function monitors proper switchoff of the relevant circuit breaker.

2.12.1 Description

General

If after a programmable time delay, the circuit breaker has not opened, breaker failure protection issues a trip signal via a superordinate circuit breaker (see example in the figure below).

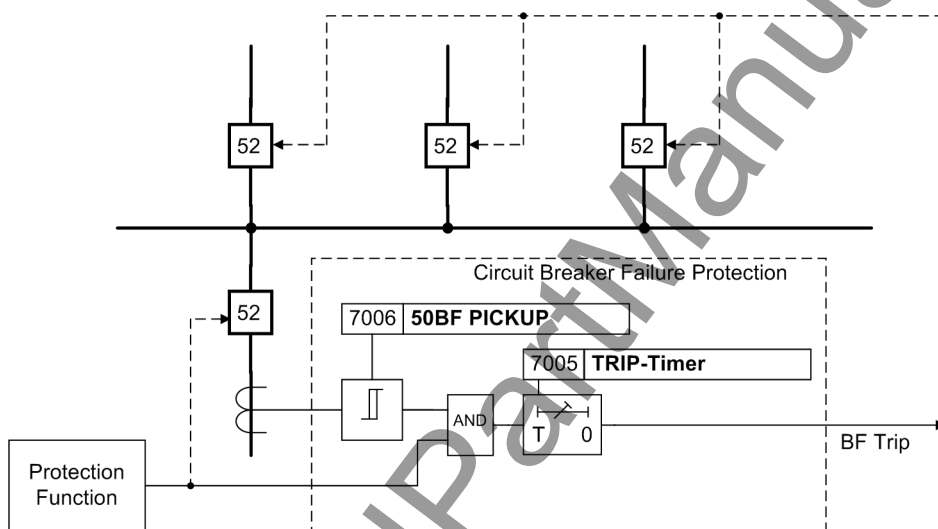

Figure 2-62 Function principle of the breaker failure protection

Initiation

The breaker failure protection function can be initiated by two different sources:

- Trip signals of internal protective functions of the 7SJ61,
- external trip signals via binary inputs („>50BF ext SRC“).

For each of the two sources, a unique pickup message is generated, a unique time delay is initiated, and a unique trip signal is generated. The setting values of current threshold and delay time apply to both sources.

Criteria

There are two criteria for breaker failure detection:

- Check whether the current flow has effectively disappeared after a tripping command was issued,
- Evaluate the circuit breaker's auxiliary contacts.

The criteria used to determine if the circuit breaker has operated is selectable and should depend on the protective function that initiated the breaker failure function. On tripping without fault current, the current below the threshold **50BF PICKUP** is not a reliable indication of the proper functioning of the circuit breaker. In such cases, pickup exclusively depends on the auxiliary contact criterion. In protection functions based on the measurement of currents (including all short-circuit protection functions), the current flow is a preferential criterion, i.e. it is given priority, as opposed to the auxiliary contacts. If current flows above the set threshold or thresholds (**enabled w/ 3I0>**) are detected, the breaker failure protection trips even if the auxiliary criterion indicates „Breaker Open“.

Monitoring of the Current Flow

Address 170 **50BF** can be set in such a way that either the current criterion can already be met by a single phase current (setting **Enabled**) or that another current is taken into consideration in order to check the plausibility (setting **enabled w/ 3I0>**), see Figure 2-63.

The currents are filtered through numerical filters to evaluate the fundamental harmonic. They are monitored and compared to the set limit value. Besides the three phase currents, two further current thresholds are provided in order to allow a plausibility check. For purposes of the plausibility check, a configuration of a separate threshold value can be applied accordingly. (see Figure 2-63).

The ground current I_N ($3 \cdot I_0$) is preferably used as plausibility current. Via the parameters 613 you decide whether the measured (**I_{gnd} (measured)**) or the calculated (**3I0 (calcul.)**) values are to be used. In case of system faults not involving ground currents, no increased ground currents/residual currents are flowing, and therefore the calculated triple negative sequence current $3 \cdot I_2$ or a second phase current is used as plausibility current.

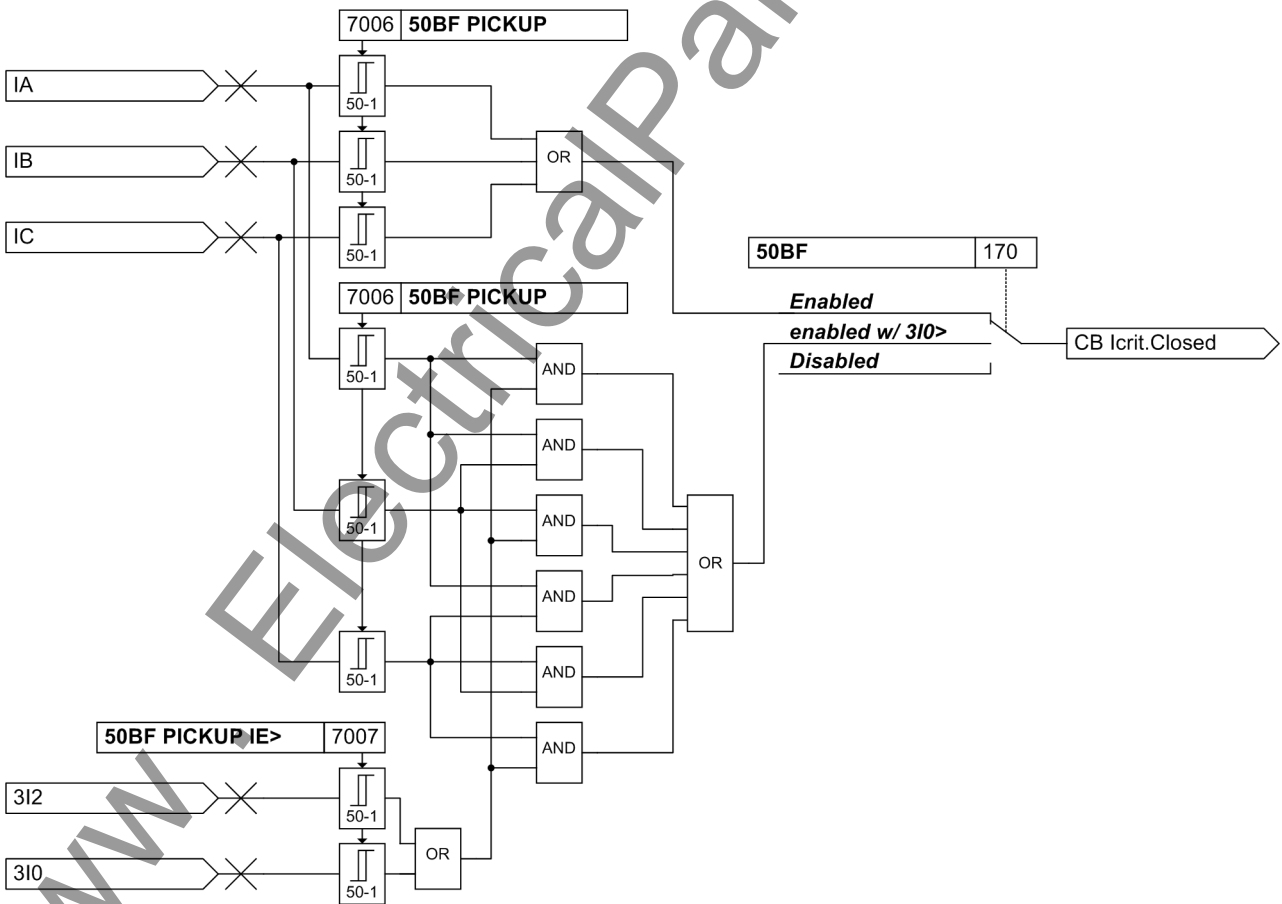

Figure 2-63 Monitoring of the current flow

Monitoring of the Circuit Breaker Auxiliary Contacts

Evaluation of the circuit breaker's auxiliary contacts depends on the type of contacts, and how they are connected to the binary inputs:

- the auxiliary contacts for circuit breaker "open" (4602 „>52 - b“) and "closed" (4601 „>52 - a“) are configured,
- only the auxiliary contact for circuit breaker "open" is configured(4602 „>52 - b“),
- only the auxiliary contact for circuit breaker "closed" is configured(4601 „>52 - a“),
- none of the two auxiliary contacts is configured.

Feedback information of the auxiliary status of the circuit breaker is evaluated, depending on the allocation of binary inputs and auxiliary contacts. After a trip command has been issued it is the aim to detect — if possible — by means of the feedback of the circuit breaker's auxiliary contacts whether the breaker is open or in intermediate position. If valid, this information can be used for a proper initiation of the breaker failure protection function.

The logic diagram illustrates the monitoring of the circuit breaker's auxiliary contacts.

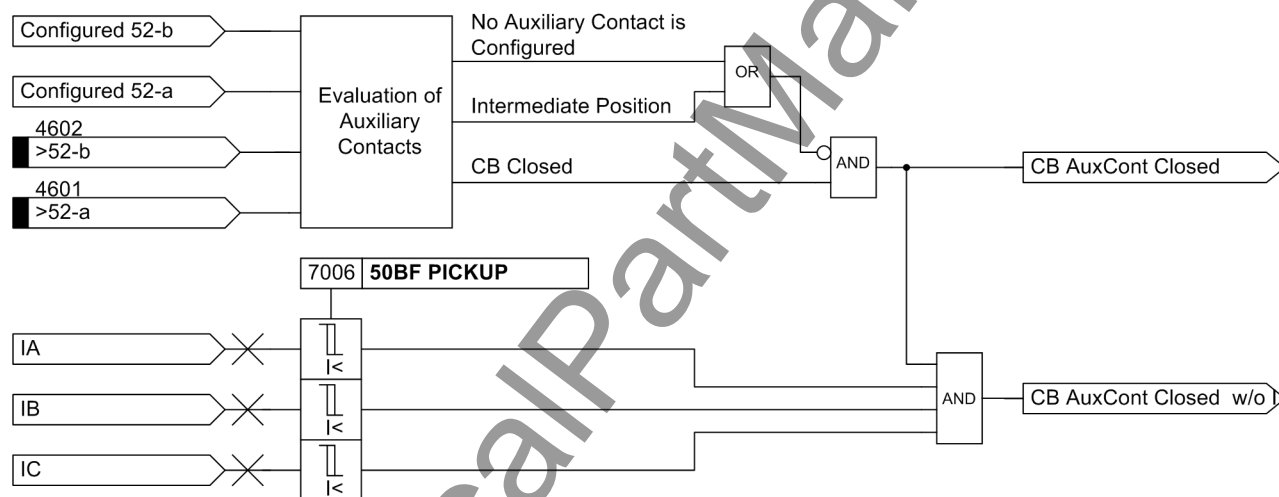

Figure 2-64 Logic diagram for breaker failure protection, monitoring of the circuit-breaker auxiliary contacts

Logic

If breaker failure protection is initiated, an alarm message is generated and a settable delay time is started. If once the time delay has elapsed, criteria for a pickup are still met, a trip signal is issued to a superordinate circuit breaker. Therefore, the trip signal issued by the circuit breaker failure protection is configured to one of the output relays.

If the criteria that led to the pickup are no longer met when the time delay has elapsed, such pickup thus drops out and no trip signal is issued by the breaker failure protection function.

To protect against nuisance tripping due to excessive contact bounce, a stabilization of the binary inputs for external trip signals takes place. This external signal must be present during the entire period of the delay time, otherwise the timer is reset and no trip signal is issued.

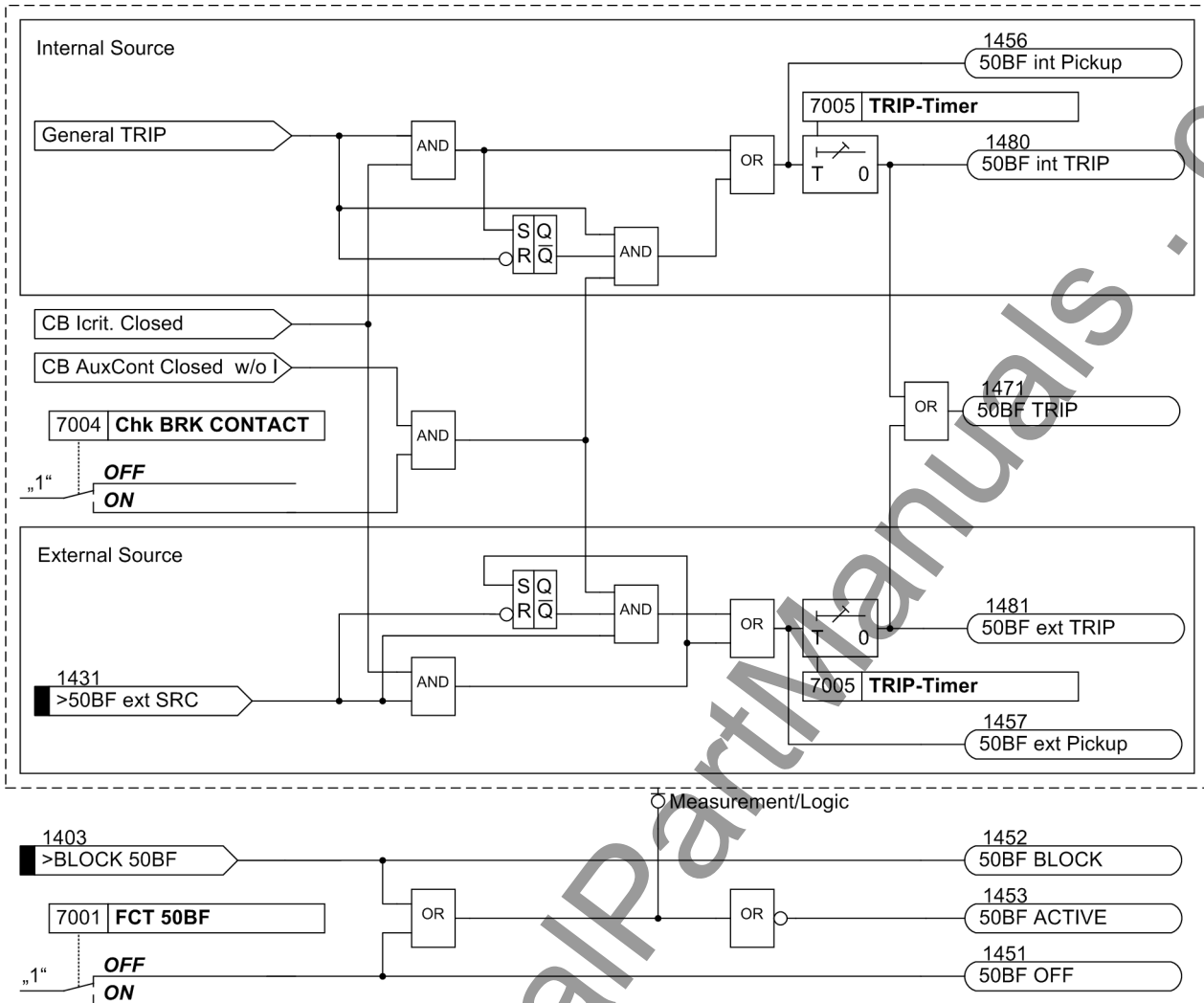

Figure 2-65 Logic diagram of the breaker failure protection

2.12.2 Setting Notes

General

Breaker failure protection is only effective and accessible if address 170 **50BF** is set to **Enabled** or **enabled w/ 3IO>**. Setting **Enabled** considers the three phase currents for total current monitoring. Setting **enabled w/ 3IO>** additionally evaluates the ground current or the negative sequence system when only one phase current occurs.

If this function is not required, then **Disabled** is set. The function can be set to **ON** or **OFF** under address 7001 **FCT 50BF**.

Criteria

Address 7004 **Chk BRK CONTACT** establishes whether or not a breaker auxiliary contact is used, via a binary input, as one of the criteria for pickup. If this address is set to **ON**, then the current criterion and/or the auxiliary contact criterion apply. This setting must be selected if the circuit-breaker failure protection is started by functions which do not always have a certain criterion for detection of an open circuit breaker.

Time Delay

The time delay is entered at address 7005 **TRIP - Timer**. This setting should be based on the maximum circuit breaker operating time plus the dropout time of the current flow monitoring element plus a safety margin which takes into consideration the tolerance of the time delay. Figure 2-66 illustrates the time sequences.

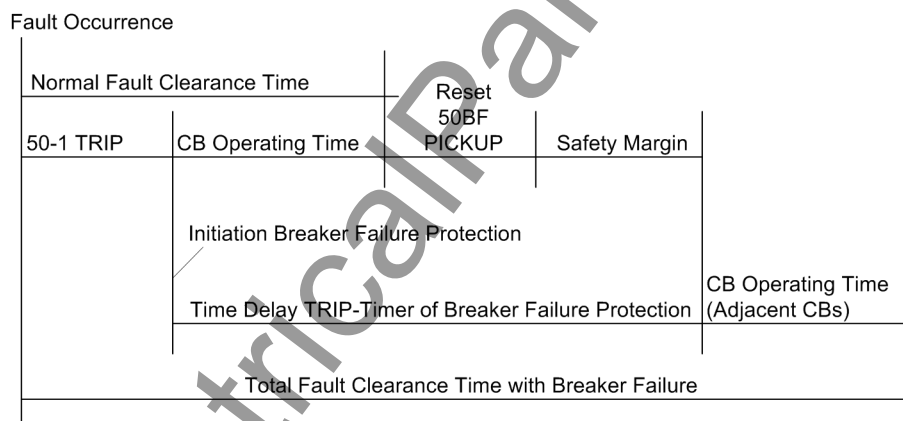

Figure 2-66 Time sequence example for normal clearance of a fault, and with circuit breaker failure

Pickup Values

The pickup value of the current flow monitoring is set under address 7006 **50BF PICKUP**, and the pickup value of the ground current monitoring under address 7007 **50BF PICKUP IE>**. The threshold values must be set at a level below the minimum fault current for which the total current monitoring must operate. A setting of 10% below the minimum fault current for which breaker failure protection must operate is recommended. The pickup value should not be set too low since otherwise there is a risk that transients in the current transformer secondary circuit may lead to extended dropout times if extremely high currents are switched off.

2.12.3 Settings

The table indicates region-specific default settings. Column C (configuration) indicates the corresponding secondary nominal current of the current transformer.

Addr.	Parameter	C	Setting Options	Default Setting	Comments
7001	FCT 50BF		OFF ON	OFF	50BF Breaker Failure Protection
7004	Chk BRK CONTACT		OFF ON	OFF	Check Breaker contacts
7005	TRIP-Timer		0.06 .. 60.00 sec; ∞	0.25 sec	TRIP-Timer
7006	50BF PICKUP	1A	0.05 .. 20.00 A	0.10 A	50BF Pickup current threshold
		5A	0.25 .. 100.00 A	0.50 A	
7007	50BF PICKUP IE>	1A	0.05 .. 20.00 A	0.10 A	50BF Pickup earth current threshold
		5A	0.25 .. 100.00 A	0.50 A	

2.12.4 Information List

No.	Information	Type of Information	Comments
1403	>BLOCK 50BF	SP	>BLOCK 50BF
1431	>50BF ext SRC	SP	>50BF initiated externally
1451	50BF OFF	OUT	50BF is switched OFF
1452	50BF BLOCK	OUT	50BF is BLOCKED
1453	50BF ACTIVE	OUT	50BF is ACTIVE
1456	50BF int Pickup	OUT	50BF (internal) PICKUP
1457	50BF ext Pickup	OUT	50BF (external) PICKUP
1471	50BF TRIP	OUT	50BF TRIP
1480	50BF int TRIP	OUT	50BF (internal) TRIP
1481	50BF ext TRIP	OUT	50BF (external) TRIP

2.13 Flexible Protection Functions

The flexible protection function is a generally valid protection function, which application depends on the configuration of different protection principles. A maximum of 20 flexible protection functions can be created. Each function can be applied as an independent protection function, as an additional protection element of an already existing protection function or as a universal logic, e.g. for monitoring tasks.

2.13.1 Function Description

General

The function is a combination of a standard protection logic and a characteristic (measured quantity or derived quantity) that is adjustable via parameters. The characteristics indicated in Table 2-11 and the derived protection functions are available.

Table 2-11 Possible Protection Functions

Characteristic Group	Characteristic / Measured Quantity		Protective Function	ANSI No.	Mode of Operation	
					3-phase	1-phase
Current	I	RMS value of fundamental component	Time overcurrent protection	50, 50G	X	X
	I_{rms}	True RMS (r.m.s. value)	Time overcurrent protection Overload protection	50, 50G	X	X
	$3I_0$	Zero sequence system	Time overcurrent protection, ground	50N	X	
	I1	Positive-sequence component			X	
	I2	Negative-sequence component	Negative sequence protection	46	X	
	I2/I1	Positive/negative sequence component ratio	-		X	
Binary input	-	Binary input	External trip commands		without phase reference	

The maximum 20 configurable protection functions operate independently of each other. The following description concerns one function; it can be applied accordingly to all other flexible functions. The logic diagram in Figure 2-67 illustrates the description.

Function Control

The function can be switched **ON** or **OFF**. The state **Alarm Only** can also be enabled. In this state the pickup will not result in a fault and the trip command delay time is not started. Tripping is thus not possible.

If changes of Power System Data 1 are effected after configuration of the flexible functions, it may be possible that the sequence of the functions is not configured correctly. This is indicated by message (Fno. „\$00 inval. set“). This function is not active in this case and the configuration of the function must be adjusted.

Blocking Functions

The function can be blocked via binary input (FNo. 235.2110 „>BLOCK \$00“) via local operating terminal („Control“ -> „Tagging“ -> „Set“). Blocking will reset the function's entire measurement logic as well as all running times and indications. Blocking via the local operating terminal may be useful if the function is in a status of permanent pickup which does not allow the function to be reset.

Mode of Operation, Measured Quantity, Measurement Method

The flexible function can be tailored to assume a specific protective function for a concrete application in parameters **OPERRAT. MODE**, **MEAS. QUANTITY**, **MEAS. METHOD** and **PICKUP WITH**. Parameter **OPERRAT. MODE** can be set to specify whether the function works **3-phase**, **1-phase** or **no reference**, i.e. without a fixed phase reference. The three-phase method evaluates all three phases in parallel. This implies that threshold evaluation, pickup indications and trip time delay are accomplished selectively for each phase and parallel to each other. This may be for example the typical operating principle of a three-phase time overcurrent protection. When operating single-phase, the function employs either a phase's measured quantity, which must be stated explicitly, (e.g. evaluating only the current in phase **I_b**) or the measured ground current **I_n**. If external trip commands are used, the operating principle is without (fixed) phase reference. Additional parameters can be set to specify the used **MEAS. QUANTITY** and the **MEAS. METHOD**. The **MEAS. METHOD** determines whether the function uses the r.m.s. value of the fundamental component or the normal r.m.s. value (true RMS) that evaluates also harmonics. Parameter **PICKUP WITH** moreover specifies whether the function picks up on exceeding the threshold (>-element) or on falling below the threshold (<-element).

Characteristic Curve

The characteristic curve of the function is always „independent“, i.e. the delay time is not influenced by the measured value.

Functional Logic

Figure 2-67 shows the logic diagram for a three-phase operating function. In case of a single-phase operating method or without phase reference, phase-selectivity and thus the phase-specific messages are omitted.

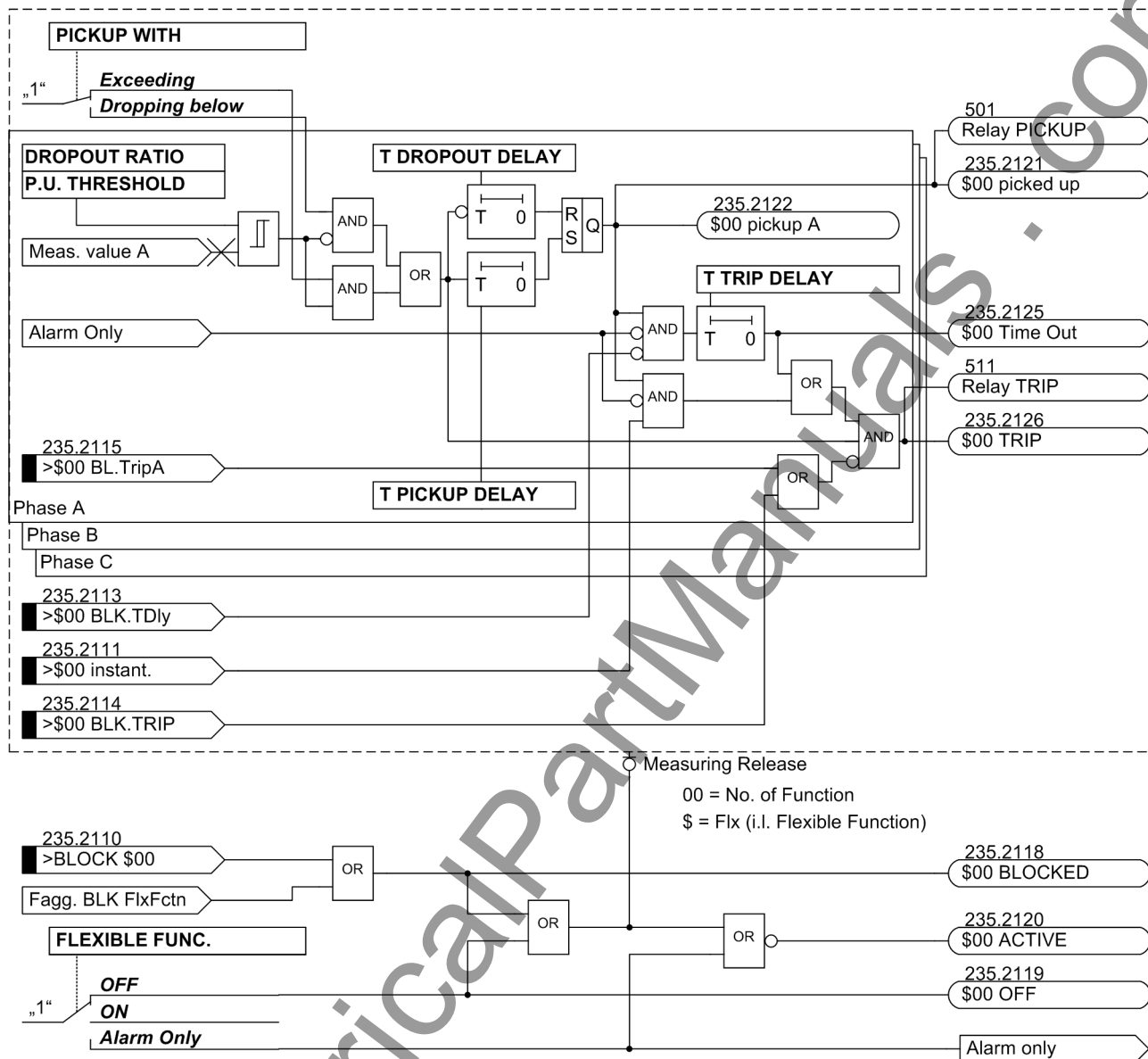

Figure 2-67 Logic diagram of flexible protection functions

Depending on the configuration, the set threshold value is monitored with regard to exceeding or undershooting. On exceeding the threshold value (>-element), the configured trigger delay time is started. On expiry of this delay time and continuous exceeding of the threshold values, the picked-up phase (e.g. Fno. 235.2122 „\$00 pickup A“) as well as the triggered function (Fno. 235.2121 „\$00 picked up“) are reported. If the trigger delay time is set to zero, pickup occurs together with the recognition of exceeded threshold values. If this function is enabled, the trip command delay time as well as fault recording is started on pickup. If the setting is set to "Message only", this does not occur. If the threshold values continue to be exceeded after expiry of the trip command delay time, the trip command is generated. 235.2126 „\$00 TRIP“). Time expiry is reported via (Fno. 235.2125 „\$00 Time Out“). Expiry of the trip command delay time can be blocked via binary input (Fno. 235.2113 „>\$00 BLK. TDly“). As long as the binary input is active, the time is not started, hence tripping cannot occur. On dropout of the binary input and continuous pickup, the time is started. Expiry of the delay time can be bypassed by activating the binary input (Fno. 235.2111 „>\$00 instant.“). If pickup continues and the binary input is activated, tripping will occur immediately. Sending of the trip command can be blocked via the binary inputs (Fno. 235.2115 „>\$00 BL. TripA“) and (Fno. 235.2114 „>\$00 BLK. TRIP“). The phase-selective trip-command blocking is required for interaction with the inrush restraint (see „Interaction with

other Functions“). The dropout ratio of the function can be configured. Should undershooting of the set dropout value occur after pickup (>-element), then the dropout delay time is started. Pickup is further maintained during this time and a started trip command delay time continues to run. Should the trip command delay time expire while the dropout delay time is still running, a trip command will occur only be generated if the threshold value is exceeded at this time. Only upon expiry of the dropout delay time, the pickup drops out. If the time is configured to zero, the dropout occurs immediately upon undershooting of the threshold value.

Direct Coupling

The direct coupling is not explicitly shown in the logic diagram as the functionality is analogous. When the binary input to the direct coupling (Fno. 235.2112 „>\$00 Dir. TRIP“) is activated, this is treated like an exceeding of the threshold value, i.e. the pickup delay time is started upon activation. If it is set to zero, the pickup is reported immediately and the trip command delay time is started. The logic functions as illustrated in Figure 2-67.

Interaction with other Functions

The flexible protection functions interact with different other functions, e.g.

- with the Circuit-breaker Failure Protection:

The circuit-breaker failure protection is automatically started if the function generates a trip command. However, tripping only occurs if the current criterion is fulfilled at that time, i.e. the set minimum current threshold 7006 **50BF PICKUP** is exceeded.

- With the Automatic Reclosure Function (AR):

Initiation of the AR cannot occur directly. For interaction with the AR, the trip command of the flexible function must be linked via CFC with binary input Fno. 2716 „>Start 79 Ph“ or Fno. 2715 „>Start 79 Gnd“. If operating time is used, the pickup of the flexible function must be linked additionally with the binary input Fno. 2711 „>79 Start“.

- With the Inrush Restraint:

A direct interaction with the inrush restraint is not possible. If a flexible function is supposed to be blocked by the inrush restraint, this blocking must be carried out via CFC. For a phase-selective operation method, the flexible function makes provision for three binary inputs for a phase-selective trip-command blocking (Fno. 235.2115 to 235.2117). These must be linked with the phase-selective messages for recognition of the inrush currents (Fno. 1840 to 1842). If a cross-blocking is to be implemented, the phase-selective inrush messages are logical OR must be linked to the binary input for blocking the trip-command function (Fno. 235.2114 „>\$00 BLK. TRIP“). It is further important to note that the flexible function must be delayed by at least 20 ms so that the inrush restraint can pickup safely before the flexible function.

- With the Overall Device Logic:

The pickup message of the flexible function is included in the general fault detection, and tripping in the general trip (see Chapter 2.16). All functionalities linked to the general fault detection and general trip therefore also apply to the flexible function.

The trip commands by the flexible protection function are maintained after reset of the pickup for at least the configured minimum trip-command duration 210 T TRIPCOM MIN.

2.13.2 Setting Notes

The setting of the functional scope determines the number of flexible protection functions to be used (see Chapter 2.1.1). If a flexible function in the functional scope is disabled (by removing the checkmark), this will result in losing all settings and configurations of this function or its settings will be reset to their default settings.

Introduction

In the DIGSI setting dialog „General“, parameter **FLEXIBLE FUNC.** can be set to **OFF**, **ON** or **Alarm Only**. If the function is enabled in operational mode **Alarm Only**, no faults are recorded, no „Effective“-indication is generated, no trip command issued and neither will the circuit-breaker protection be affected. Therefore, this operational mode is preferred when a flexible function is not required to operate as a protection function. Furthermore, the **OPERRAT. MODE** can be configured:

3-phase – functions evaluate the three-phase measuring system, i.e. all three phases are processed simultaneously. A typical example is the three-phase operating time overcurrent protection.

Single-phase – functions evaluate only the individual measuring value. This can be an individual phase value (e.g. I_B) or a ground variable (I_G).

The setting **no reference** allows to use external trip commands.

Measured Quantity

In the setting dialog „Measured Variable“ the measured variables to be evaluated by the flexible protection functions can be selected, which may be a calculated or a directly measured variable. The setting options that can be selected here are dependant on the mode of measured-value processing as predefined in parameter **OPERRAT. MODE** (see the following table).

Table 2-12 Parameter “Operating Mode” and “Measured Quantity”

Parameter OPERRAT. MODE Setting	Parameter MEAS. QUANTITY Setting Options
Single-phase, Three-phase	Current
Without Reference	Binary Input

Measurement Procedures

The measurement procedures shown in the tables below can be configured. The dependencies of the available measurement procedures of configurable modes of operation are also indicated.

Table 2-13 Parameters in the Setting Dialog "Measurement Procedure", Mode of Operation 3-phase

Mode of Operation		Notes
Three-phase	Parameter MEAS. METHOD Setting Options	
	Fundamental Harmonic	Only the fundamental harmonic is evaluated, higher harmonics are suppressed. This is the standard measurement procedure of the protection functions.
	True RMS	The "true" RMS value is determined, i.e. higher harmonics are evaluated. This procedure is applied, for example, if an overload protection element must be realized on the basis of a current measurement, as the higher harmonics contribute to thermal heating.
	Positive Sequence System, Negative Sequence System, Zero Sequence System	In order to realize certain applications, the positive sequence system or negative sequence system can be configured as measurement procedure. Example: - I2 (tripping monitoring system) Via the selection zero-sequence system, additional zero-sequence current functions can be realized that operate independent of the ground variable IN, which is measured directly via transformers.
	Ratio I2/I1	The ratio negative/positive sequence current is evaluated

Table 2-14 Parameters in the Setting Dialog "Measurement Procedure", Mode of Operation 1-phase

Mode of Operation		Notes
Single-phase	Parameters MEAS. METHOD Setting Options	
	Fundamental Harmonic	Only the fundamental harmonic is evaluated, higher harmonics are suppressed. This is the standard measurement procedure of the protection functions.
	True RMS	The „True“ RMS value is determined, i.e. higher harmonics are evaluated. This procedure is applied, for example, if an overload protection element must be realized on the basis of a current measurement, as the higher harmonics contribute to thermal heating.
	Parameters CURRENT Setting Options	
	IA IB IC IN INS IN2	It is determined which current-measuring channel must be evaluated by the function. Depending on the device version, either IN (normal-sensitive ground current input) or INS (sensitive ground current input) and IN2 (second ground current connected to the device) can be selected.

Via parameter **PICKUP WITH** it is determined whether the function must be triggered on exceeding or under-shooting of the set threshold value.

Settings

The pickup thresholds, delay times and dropout ratios of the flexible protection function are set in the „Settings“ dialog box in DIGSI.

The pickup threshold of the function is configured via parameter **P . U . THRESHOLD**. The OFF-command delay time is set via parameter **T TRIP DELAY**. Both setting values must be selected according to the required application.

The pickup can be delayed via parameter **T PICKUP DELAY**. This parameter is usually set to zero (default setting) in protection applications, because a protection function should pick up as quickly as possible. A setting deviating from zero may be appropriate if a trip log is not desired to be started upon each short-term exceeding of the pickup threshold, for example, with power protection or when a function is not used as a protection, but as a monitoring function.

The dropout of pickup can be delayed via parameter **T DROPOUT DELAY**. This setting is also set to zero by default (standard setting) A setting deviating from zero may be required if the device is utilized together with electro-magnetic devices with considerably longer dropout ratios than the digital protection device (see Chapter 2.2 for more information). When utilizing the dropout time delay, it is recommended to set it to a shorter time than the OFF-command delay time in order to avoid both times to "face".

The dropout ratio of the function can be selected in parameter **DROPOUT RATIO**. The standard dropout ratio of protection functions is 0.95 (default setting). If the symmetrical current components are used, a dropout ratio of at least 0.9 should be set. If the dropout ratio is decreased, it would be sensible to test the pickup of the function regarding possible "chatter".

Renaming Messages, Checking Configurations

After parameterization of a flexible function, the following steps should be noted:

- Open matrix in DIGSI
- Rename the neutral message texts in accordance with the application.
- Check configurations on contacts and in operation and fault buffer, or set them according to the requirements.

2.13.3 Settings

Addresses which have an appended "A" can only be changed with DIGSI, under "Display Additional Settings"

Addr.	Parameter	Setting Options	Default Setting	Comments
0	FLEXIBLE FUNC.	OFF ON Alarm Only	OFF	Flexible Function
0	OPERRAT. MODE	3-phase 1-phase no reference	3-phase	Mode of Operation
0	MEAS. QUANTITY	Please select Current Binary Input	Please select	Selection of Measured Quantity
0	MEAS. METHOD	Fundamental True RMS Positive seq. Negative seq. Zero sequence Ratio I2/I1	Fundamental	Selection of Measurement Method
0	PICKUP WITH	Exceeding Dropping below	Exceeding	Pickup with
0	CURRENT	Ia Ib Ic In In sensitive In2	Ia	Current
0	P.U. THRESHOLD	Pickup Threshold		
0	P.U. THRESHOLD	Pickup Threshold		
0	P.U. THRESHOLD	0.001 .. 1.500 A	0.100 A	Pickup Threshold
0	P.U. THRESHOLD	15 .. 100 %	20 %	Pickup Threshold
0	T TRIP DELAY	0.00 .. 3600.00 sec	1.00 sec	Trip Time Delay
0	T PICKUP DELAY	0.00 .. 60.00 sec	0.00 sec	Pickup Time Delay
0A	T DROPOUT DELAY	0.00 .. 60.00 sec	0.00 sec	Dropout Time Delay
0A	DROPOUT RATIO	0.70 .. 0.99	0.95	Dropout Ratio
0A	DROPOUT RATIO	1.01 .. 3.00	1.05	Dropout Ratio

2.13.4 Information List

No.	Information	Type of Information	Comments
235.2110	>BLOCK \$00	SP	>BLOCK Function \$00
235.2111	>\$00 instant.	SP	>Function \$00 instantaneous TRIP
235.2112	>\$00 Dir.TRIP	SP	>Function \$00 Direct TRIP
235.2113	>\$00 BLK.TDly	SP	>Function \$00 BLOCK TRIP Time Delay
235.2114	>\$00 BLK.TRIP	SP	>Function \$00 BLOCK TRIP
235.2115	>\$00 BL.TripA	SP	>Function \$00 BLOCK TRIP Phase A
235.2116	>\$00 BL.TripB	SP	>Function \$00 BLOCK TRIP Phase B
235.2117	>\$00 BL.TripC	SP	>Function \$00 BLOCK TRIP Phase C
235.2118	\$00 BLOCKED	OUT	Function \$00 is BLOCKED
235.2119	\$00 OFF	OUT	Function \$00 is switched OFF
235.2120	\$00 ACTIVE	OUT	Function \$00 is ACTIVE
235.2121	\$00 picked up	OUT	Function \$00 picked up
235.2122	\$00 pickup A	OUT	Function \$00 Pickup Phase A
235.2123	\$00 pickup B	OUT	Function \$00 Pickup Phase B
235.2124	\$00 pickup C	OUT	Function \$00 Pickup Phase C
235.2125	\$00 Time Out	OUT	Function \$00 TRIP Delay Time Out
235.2126	\$00 TRIP	OUT	Function \$00 TRIP
236.2127	BLK. Flex.Fct.	IntSP	BLOCK Flexible Function
235.2128	\$00 inval.set	OUT	Function \$00 has invalid settings

2.14 Temperature Detection via RTD Boxes

Up to two temperature detection units (RTD-boxes) with 12 measuring sensors in total can be applied for temperature detection and are recognized by the protection device.

Applications

- In particular the RTDs enable the thermal status of motors, generators and transformers to be monitored. Rotating machines are additionally monitored for a violation of the bearing temperature thresholds. The temperatures are measured in different locations of the protected object by employing temperature sensors (RTD = Resistance Temperature Detector) and are transmitted to the device via one or two 7XV566 RTD-boxes.

2.14.1 Description

RTD-box 7XV56

The RTD-box 7XV566 is an external device mounted on a standard DIN rail. It features 6 temperature detectors and one RS485 interface for communication with the protection device. The RTD-box detects the coolant temperature of each measuring point from the resistance value of the temperature detectors (Pt 100, Ni 100 or Ni 120) connected via two- or three-wires and converts it to a numerical value. The numerical values are made available at a serial port.

Communication with the Protection Device

The protection device can employ with up to 2 RTD-boxes via its service port (port C).

Therefore, up to 12 temperature measuring points are available in this way. For greater distances to the protection device the communication via fiber optic cables is recommended. Alternative communication structures are shown in Appendix A.3.

Processing Temperatures

The transmitted raw temperature data is converted to a temperature in degrees Celsius or Fahrenheit. The conversion depends on the temperature sensor used.

For each temperature detector two threshold decisions can be performed which are available for further processing. The user can make the corresponding allocations in the configuration matrix.

Each temperature input issues an alarm in case of a short-circuit or an interruption of the sensor circuit or if a sensor is configured but not assigned. Additionally, a group annunciation is generated via all 6 temperature inputs of an RTD-box (14101 „Fail: RTD“). In case of a communication fault, an alarm of the entire RTD-box is issued (264 „Fail: RTD-Box 1“ or 267 „Fail: RTD-Box 2“).

The following figure shows the logic diagram for temperature processing.

The manual supplied with the RTD-box contains a connection diagram and dimensioned drawing.

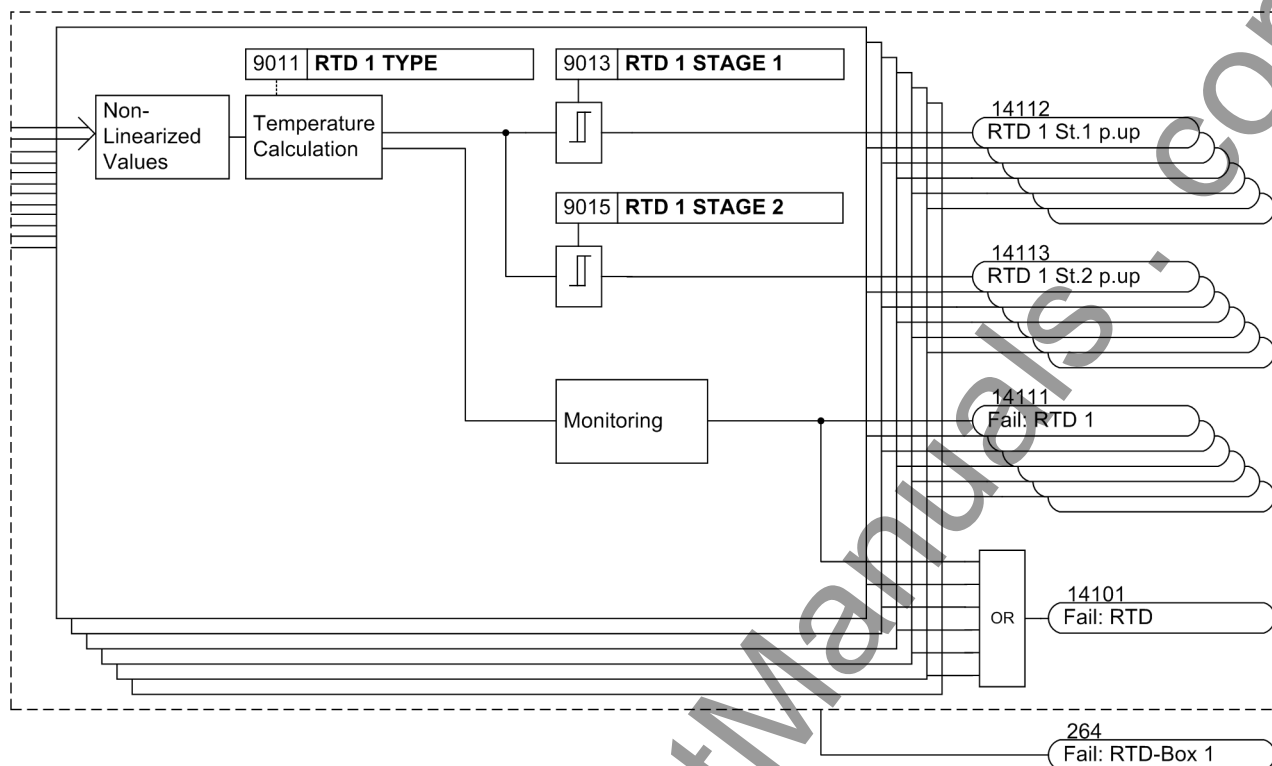

Figure 2-68 Logic diagram of the temperature processing for RTD-box 1

2.14.2 Setting Notes

General

Temperature detection is only effective and accessible if this protective function was allocated to an interface during configuration (Sub-section 2.1.1). At address 190 **RTD-BOX INPUT** the RTD-box(es) is allocated to the interface at which it will be operated (e.g. port C). The number of sensor inputs and the communication mode were set at address 191 **RTD CONNECTION**. The temperature unit (°C or °F) was set in the Power System Data 1 at address 276 **TEMP. UNIT**.

If the RTD-boxes are operated in half-duplex mode, the flow control (CTS) must be selected by means of a plug-in jumper (see Section 3.1.2 in Chapter „Mounting and Commissioning“) „/CTS enabled by /RTS“.

Device Settings

The settings are the same for each input and are here shown at the example of measuring input 1.

Set the type of temperature detector for RTD 1 (temperature sensor for measuring point 1) at address 9011 **RTD 1 TYPE**. You can choose between , *Ni 120* Ω and *Ni 100* Ω. If no temperature detector is available for RTD 1, set **RTD 1 TYPE** = *Not connected*. This parameter can only be changed in DIGSI under „Display Additional Settings“.

Address 9012 **RTD 1 LOCATION** informs the device about the mounting location of RTD 1. You can choose between *Oil*, *Ambient*, *Winding*, *Bearing* and *Other*. The selection is not evaluated in the device but only serves the purpose of providing information about the medium in which the temperature measurement is carried out. This parameter can only be changed in DIGSI under „Display Additional Settings“.

You can also set an alarm temperature and a tripping temperature. Depending on the temperature unit selected in the Power System Data (Section 2.1.1.2 in address 276 **TEMP. UNIT**), the alarm temperature can be expressed in degrees Celsius (°C) (address 9013 **RTD 1 STAGE 1**) or degrees Fahrenheit (°F) (address 9014 **RTD 1 STAGE 1**). The tripping temperature is set to degrees Celsius (°C) in address 9015 **RTD 1 STAGE 2** or to degrees Fahrenheit (°F) at address 9016 **RTD 1 STAGE 2**.

The settings for all temperature detectors connected are made accordingly.

RTD-box Settings

If temperature detectors are used with two-wire connection, the line resistance (for short-circuited temperature detector) must be measured and adjusted. For this purpose, select mode 6 in the RTD-box and enter the resistance value for the corresponding temperature detector (range 0 to 50.6 Ω). If a 3-wire connection is used, no further settings are required to this end.

A baudrate of 9600 bits/s ensures communication. Parity is even. The factory setting of the bus number 0. Modifications at the RTD-box can be made in mode 7. The following convention applies:

Table 2-15 Setting the bus address at the RTD-box

Mode	Number of RTD-boxes	Address
simplex	1	0
half duplex	1	1
half duplex	2	1st RTD box: 1
		2nd RTD box: 2

Further information is provided in the operating manual of the RTD-box.

Processing Measured Values and Messages

The RTD-box is visible in DIGSI as part of the 7SJ61 protection devices, i.e. messages and measured values appear in the configuration matrix similar to those of the internal functions, and can be configured and processed in the same way. Messages and measured values can thus be forwarded to the integrated user-defined logic (CFC) and interconnected as desired. Pickup signals „RTD x St. 1 p.up“ and „RTD x St. 2 p.up“, however, are neither included in the group alarms 501 „Relay PICKUP“ and 511 „Relay TRIP“ nor do they trigger a trip log.

If it is desired that a message should appear in the event log, a cross must be entered in the intersecting box of column/row.

2.14.3 Settings

Addresses which have an appended "A" can only be changed with DIGSI, under "Display Additional Settings".

Addr.	Parameter	Setting Options	Default Setting	Comments
9011A	RTD 1 TYPE	Not connected Pt 100 Ω Ni 120 Ω Ni 100 Ω	Pt 100 Ω	RTD 1: Type
9012A	RTD 1 LOCATION	Oil Ambient Winding Bearing Other	Oil	RTD 1: Location
9013	RTD 1 STAGE 1	-50 .. 250 $^{\circ}\text{C}$; ∞	100 $^{\circ}\text{C}$	RTD 1: Temperature Stage 1 Pickup
9014	RTD 1 STAGE 1	-58 .. 482 $^{\circ}\text{F}$; ∞	212 $^{\circ}\text{F}$	RTD 1: Temperature Stage 1 Pickup
9015	RTD 1 STAGE 2	-50 .. 250 $^{\circ}\text{C}$; ∞	120 $^{\circ}\text{C}$	RTD 1: Temperature Stage 2 Pickup
9016	RTD 1 STAGE 2	-58 .. 482 $^{\circ}\text{F}$; ∞	248 $^{\circ}\text{F}$	RTD 1: Temperature Stage 2 Pickup
9021A	RTD 2 TYPE	Not connected Pt 100 Ω Ni 120 Ω Ni 100 Ω	Not connected	RTD 2: Type
9022A	RTD 2 LOCATION	Oil Ambient Winding Bearing Other	Other	RTD 2: Location
9023	RTD 2 STAGE 1	-50 .. 250 $^{\circ}\text{C}$; ∞	100 $^{\circ}\text{C}$	RTD 2: Temperature Stage 1 Pickup
9024	RTD 2 STAGE 1	-58 .. 482 $^{\circ}\text{F}$; ∞	212 $^{\circ}\text{F}$	RTD 2: Temperature Stage 1 Pickup
9025	RTD 2 STAGE 2	-50 .. 250 $^{\circ}\text{C}$; ∞	120 $^{\circ}\text{C}$	RTD 2: Temperature Stage 2 Pickup
9026	RTD 2 STAGE 2	-58 .. 482 $^{\circ}\text{F}$; ∞	248 $^{\circ}\text{F}$	RTD 2: Temperature Stage 2 Pickup
9031A	RTD 3 TYPE	Not connected Pt 100 Ω Ni 120 Ω Ni 100 Ω	Not connected	RTD 3: Type
9032A	RTD 3 LOCATION	Oil Ambient Winding Bearing Other	Other	RTD 3: Location
9033	RTD 3 STAGE 1	-50 .. 250 $^{\circ}\text{C}$; ∞	100 $^{\circ}\text{C}$	RTD 3: Temperature Stage 1 Pickup

Addr.	Parameter	Setting Options	Default Setting	Comments
9034	RTD 3 STAGE 1	-58 .. 482 °F; ∞	212 °F	RTD 3: Temperature Stage 1 Pickup
9035	RTD 3 STAGE 2	-50 .. 250 °C; ∞	120 °C	RTD 3: Temperature Stage 2 Pickup
9036	RTD 3 STAGE 2	-58 .. 482 °F; ∞	248 °F	RTD 3: Temperature Stage 2 Pickup
9041A	RTD 4 TYPE	Not connected Pt 100 Ω Ni 120 Ω Ni 100 Ω	Not connected	RTD 4: Type
9042A	RTD 4 LOCATION	Oil Ambient Winding Bearing Other	Other	RTD 4: Location
9043	RTD 4 STAGE 1	-50 .. 250 °C; ∞	100 °C	RTD 4: Temperature Stage 1 Pickup
9044	RTD 4 STAGE 1	-58 .. 482 °F; ∞	212 °F	RTD 4: Temperature Stage 1 Pickup
9045	RTD 4 STAGE 2	-50 .. 250 °C; ∞	120 °C	RTD 4: Temperature Stage 2 Pickup
9046	RTD 4 STAGE 2	-58 .. 482 °F; ∞	248 °F	RTD 4: Temperature Stage 2 Pickup
9051A	RTD 5 TYPE	Not connected Pt 100 Ω Ni 120 Ω Ni 100 Ω	Not connected	RTD 5: Type
9052A	RTD 5 LOCATION	Oil Ambient Winding Bearing Other	Other	RTD 5: Location
9053	RTD 5 STAGE 1	-50 .. 250 °C; ∞	100 °C	RTD 5: Temperature Stage 1 Pickup
9054	RTD 5 STAGE 1	-58 .. 482 °F; ∞	212 °F	RTD 5: Temperature Stage 1 Pickup
9055	RTD 5 STAGE 2	-50 .. 250 °C; ∞	120 °C	RTD 5: Temperature Stage 2 Pickup
9056	RTD 5 STAGE 2	-58 .. 482 °F; ∞	248 °F	RTD 5: Temperature Stage 2 Pickup
9061A	RTD 6 TYPE	Not connected Pt 100 Ω Ni 120 Ω Ni 100 Ω	Not connected	RTD 6: Type
9062A	RTD 6 LOCATION	Oil Ambient Winding Bearing Other	Other	RTD 6: Location

Addr.	Parameter	Setting Options	Default Setting	Comments
9063	RTD 6 STAGE 1	-50 .. 250 °C; ∞	100 °C	RTD 6: Temperature Stage 1 Pickup
9064	RTD 6 STAGE 1	-58 .. 482 °F; ∞	212 °F	RTD 6: Temperature Stage 1 Pickup
9065	RTD 6 STAGE 2	-50 .. 250 °C; ∞	120 °C	RTD 6: Temperature Stage 2 Pickup
9066	RTD 6 STAGE 2	-58 .. 482 °F; ∞	248 °F	RTD 6: Temperature Stage 2 Pickup
9071A	RTD 7 TYPE	Not connected Pt 100 Ω Ni 120 Ω Ni 100 Ω	Not connected	RTD 7: Type
9072A	RTD 7 LOCATION	Oil Ambient Winding Bearing Other	Other	RTD 7: Location
9073	RTD 7 STAGE 1	-50 .. 250 °C; ∞	100 °C	RTD 7: Temperature Stage 1 Pickup
9074	RTD 7 STAGE 1	-58 .. 482 °F; ∞	212 °F	RTD 7: Temperature Stage 1 Pickup
9075	RTD 7 STAGE 2	-50 .. 250 °C; ∞	120 °C	RTD 7: Temperature Stage 2 Pickup
9076	RTD 7 STAGE 2	-58 .. 482 °F; ∞	248 °F	RTD 7: Temperature Stage 2 Pickup
9081A	RTD 8 TYPE	Not connected Pt 100 Ω Ni 120 Ω Ni 100 Ω	Not connected	RTD 8: Type
9082A	RTD 8 LOCATION	Oil Ambient Winding Bearing Other	Other	RTD 8: Location
9083	RTD 8 STAGE 1	-50 .. 250 °C; ∞	100 °C	RTD 8: Temperature Stage 1 Pickup
9084	RTD 8 STAGE 1	-58 .. 482 °F; ∞	212 °F	RTD 8: Temperature Stage 1 Pickup
9085	RTD 8 STAGE 2	-50 .. 250 °C; ∞	120 °C	RTD 8: Temperature Stage 2 Pickup
9086	RTD 8 STAGE 2	-58 .. 482 °F; ∞	248 °F	RTD 8: Temperature Stage 2 Pickup
9091A	RTD 9 TYPE	Not connected Pt 100 Ω Ni 120 Ω Ni 100 Ω	Not connected	RTD 9: Type

Addr.	Parameter	Setting Options	Default Setting	Comments
9092A	RTD 9 LOCATION	Oil Ambient Winding Bearing Other	Other	RTD 9: Location
9093	RTD 9 STAGE 1	-50 .. 250 °C; ∞	100 °C	RTD 9: Temperature Stage 1 Pickup
9094	RTD 9 STAGE 1	-58 .. 482 °F; ∞	212 °F	RTD 9: Temperature Stage 1 Pickup
9095	RTD 9 STAGE 2	-50 .. 250 °C; ∞	120 °C	RTD 9: Temperature Stage 2 Pickup
9096	RTD 9 STAGE 2	-58 .. 482 °F; ∞	248 °F	RTD 9: Temperature Stage 2 Pickup
9101A	RTD10 TYPE	Not connected Pt 100 Ω Ni 120 Ω Ni 100 Ω	Not connected	RTD10: Type
9102A	RTD10 LOCATION	Oil Ambient Winding Bearing Other	Other	RTD10: Location
9103	RTD10 STAGE 1	-50 .. 250 °C; ∞	100 °C	RTD10: Temperature Stage 1 Pickup
9104	RTD10 STAGE 1	-58 .. 482 °F; ∞	212 °F	RTD10: Temperature Stage 1 Pickup
9105	RTD10 STAGE 2	-50 .. 250 °C; ∞	120 °C	RTD10: Temperature Stage 2 Pickup
9106	RTD10 STAGE 2	-58 .. 482 °F; ∞	248 °F	RTD10: Temperature Stage 2 Pickup
9111A	RTD11 TYPE	Not connected Pt 100 Ω Ni 120 Ω Ni 100 Ω	Not connected	RTD11: Type
9112A	RTD11 LOCATION	Oil Ambient Winding Bearing Other	Other	RTD11: Location
9113	RTD11 STAGE 1	-50 .. 250 °C; ∞	100 °C	RTD11: Temperature Stage 1 Pickup
9114	RTD11 STAGE 1	-58 .. 482 °F; ∞	212 °F	RTD11: Temperature Stage 1 Pickup
9115	RTD11 STAGE 2	-50 .. 250 °C; ∞	120 °C	RTD11: Temperature Stage 2 Pickup
9116	RTD11 STAGE 2	-58 .. 482 °F; ∞	248 °F	RTD11: Temperature Stage 2 Pickup

Addr.	Parameter	Setting Options	Default Setting	Comments
9121A	RTD12 TYPE	Not connected Pt 100 Ω Ni 120 Ω Ni 100 Ω	Not connected	RTD12: Type
9122A	RTD12 LOCATION	Oil Ambient Winding Bearing Other	Other	RTD12: Location
9123	RTD12 STAGE 1	-50 .. 250 °C; ∞	100 °C	RTD12: Temperature Stage 1 Pickup
9124	RTD12 STAGE 1	-58 .. 482 °F; ∞	212 °F	RTD12: Temperature Stage 1 Pickup
9125	RTD12 STAGE 2	-50 .. 250 °C; ∞	120 °C	RTD12: Temperature Stage 2 Pickup
9126	RTD12 STAGE 2	-58 .. 482 °F; ∞	248 °F	RTD12: Temperature Stage 2 Pickup

2.14.4 Information List

No.	Information	Type of Information	Comments
264	Fail: RTD-Box 1	OUT	Failure: RTD-Box 1
267	Fail: RTD-Box 2	OUT	Failure: RTD-Box 2
14101	Fail: RTD	OUT	Fail: RTD (broken wire/shorted)
14111	Fail: RTD 1	OUT	Fail: RTD 1 (broken wire/shorted)
14112	RTD 1 St.1 p.up	OUT	RTD 1 Temperature stage 1 picked up
14113	RTD 1 St.2 p.up	OUT	RTD 1 Temperature stage 2 picked up
14121	Fail: RTD 2	OUT	Fail: RTD 2 (broken wire/shorted)
14122	RTD 2 St.1 p.up	OUT	RTD 2 Temperature stage 1 picked up
14123	RTD 2 St.2 p.up	OUT	RTD 2 Temperature stage 2 picked up
14131	Fail: RTD 3	OUT	Fail: RTD 3 (broken wire/shorted)
14132	RTD 3 St.1 p.up	OUT	RTD 3 Temperature stage 1 picked up
14133	RTD 3 St.2 p.up	OUT	RTD 3 Temperature stage 2 picked up
14141	Fail: RTD 4	OUT	Fail: RTD 4 (broken wire/shorted)
14142	RTD 4 St.1 p.up	OUT	RTD 4 Temperature stage 1 picked up
14143	RTD 4 St.2 p.up	OUT	RTD 4 Temperature stage 2 picked up
14151	Fail: RTD 5	OUT	Fail: RTD 5 (broken wire/shorted)
14152	RTD 5 St.1 p.up	OUT	RTD 5 Temperature stage 1 picked up
14153	RTD 5 St.2 p.up	OUT	RTD 5 Temperature stage 2 picked up
14161	Fail: RTD 6	OUT	Fail: RTD 6 (broken wire/shorted)
14162	RTD 6 St.1 p.up	OUT	RTD 6 Temperature stage 1 picked up
14163	RTD 6 St.2 p.up	OUT	RTD 6 Temperature stage 2 picked up
14171	Fail: RTD 7	OUT	Fail: RTD 7 (broken wire/shorted)
14172	RTD 7 St.1 p.up	OUT	RTD 7 Temperature stage 1 picked up
14173	RTD 7 St.2 p.up	OUT	RTD 7 Temperature stage 2 picked up
14181	Fail: RTD 8	OUT	Fail: RTD 8 (broken wire/shorted)
14182	RTD 8 St.1 p.up	OUT	RTD 8 Temperature stage 1 picked up
14183	RTD 8 St.2 p.up	OUT	RTD 8 Temperature stage 2 picked up
14191	Fail: RTD 9	OUT	Fail: RTD 9 (broken wire/shorted)
14192	RTD 9 St.1 p.up	OUT	RTD 9 Temperature stage 1 picked up
14193	RTD 9 St.2 p.up	OUT	RTD 9 Temperature stage 2 picked up
14201	Fail: RTD10	OUT	Fail: RTD10 (broken wire/shorted)
14202	RTD10 St.1 p.up	OUT	RTD10 Temperature stage 1 picked up
14203	RTD10 St.2 p.up	OUT	RTD10 Temperature stage 2 picked up
14211	Fail: RTD11	OUT	Fail: RTD11 (broken wire/shorted)
14212	RTD11 St.1 p.up	OUT	RTD11 Temperature stage 1 picked up
14213	RTD11 St.2 p.up	OUT	RTD11 Temperature stage 2 picked up
14221	Fail: RTD12	OUT	Fail: RTD12 (broken wire/shorted)
14222	RTD12 St.1 p.up	OUT	RTD12 Temperature stage 1 picked up
14223	RTD12 St.2 p.up	OUT	RTD12 Temperature stage 2 picked up

2.15 Phase Rotation

A phase rotation function via binary input and parameter is implemented in 7SJ61 devices.

Applications

- Phase rotation ensures that all protective and monitoring functions operate correctly even with anti-clockwise rotation, without the need for two phases to be reversed.

2.15.1 Description

General

Various functions of the 7SJ61 device only function correctly if the phase rotation of the currents is known, e.g. unbalanced load protection and some measurement quantity monitoring functions.

If an "acb" phase rotation is normal, the appropriate setting is made during configuration of the Power System Data.

If the phase rotation can change during operation (e.g. the direction of a motor must be routinely changed), then a changeover signal at the routed binary input for this purpose is sufficient to inform the protective relay of the phase rotation reversal.

Logic

Phase rotation is permanently established at address 209 **PHASE SEQ.** (Power System Data). Via the exclusive-OR gate the binary input „>Reverse Rot.“ inverts the sense of the phase rotation applied with setting.

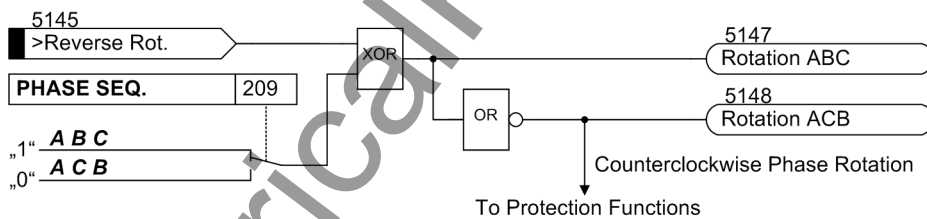

Figure 2-69 Message logic of the phase rotation reversal

Influence on Protective and Monitoring Functions

The swapping of phases directly impacts the calculation of positive and negative sequence quantities, as well as phase-to-phase voltages via the subtraction of one phase-to-ground voltage from another and vice versa. Therefore, this function is vital so that phase detection messages, fault values, and operating measurement values are not correct. As stated before, this function influences the negative protection function and some of the monitoring functions that issue messages if the required and calculated phase rotations do not match.

2.15.2 Setting Notes

Setting the Function Parameter

The normal phase sequence is set at 209 (see Section 2.1.3). If, on the system side, phase rotation is reversed temporarily, then this is communicated to the protective device using the binary input „>Reverse Rot.“ (5145).

2.16 Function Logic

The function logic coordinates the execution of protection and auxiliary functions, it processes the resulting decisions and information received from the system. This includes in particular:

- Fault Detection / Pickup Logic
- Processing Tripping Logic

2.16.1 Pickup Logic of the Entire Device

General Device Pickup

The pickup signals for all protection functions in the device are connected via an OR logic and lead to the general device pickup. It is initiated by the first function to pick up and drop out when the last function drops out. As a consequence, the following message is reported: 501 „Relay PICKUP“.

The general pickup is a prerequisite for a number of internal and external consequential functions. The following are among the internal functions controlled by general device pickup:

- Start of a trip log: From general device pickup to general device dropout, all fault messages are entered in the trip log.
- Initialization of Oscillographic Records: The storage and maintenance of oscillographic values can also be made dependent on the general device pickup.

Exception: Apart from the settings **ON** or **OFF**, some protection functions can also be set to **Alarm Only**. With setting **Alarm Only** no trip command is given, no trip log is created, fault recording is not initiated and no spontaneous fault annunciations are shown on the display.

External functions may be controlled via an output contact. Examples are:

- Automatic reclosing devices,
- Starting of additional devices, or similar.

2.16.2 Tripping Logic of the Entire Device

General Tripping

The trip signals for all protective functions are connected by OR and generate the message 511 „Relay TRIP“.

This message can be configured to an LED or binary output, just as the individual tripping messages can.

Terminating the Trip Signal

Once the trip command is output by the protection function, it is recorded as message „Relay TRIP“ (see figure 2-70). At the same time, the minimum trip command duration **TMin TRIP CMD** is started. This ensures that the command is transmitted to the circuit breaker for a sufficient amount of time, even if the function which issued the trip signal drops out quickly. The trip commands can be terminated first when the last protection function has dropped out (no function is in pickup mode) AND the minimum trip signal duration has expired.

Finally, it is possible to latch the trip signal until it is manually reset (lockout function). This allows the circuit-breaker to be locked against reclosing until the cause of the fault has been clarified and the lockout has been manually reset. The reset takes place either by pressing the LED reset key or by activating an appropriately allocated binary input („>Reset LED“). A precondition, of course, is that the circuit-breaker close coil – as usual – remains blocked as long as the trip signal is present, and that the trip coil current is interrupted by the auxiliary contact of the circuit breaker.

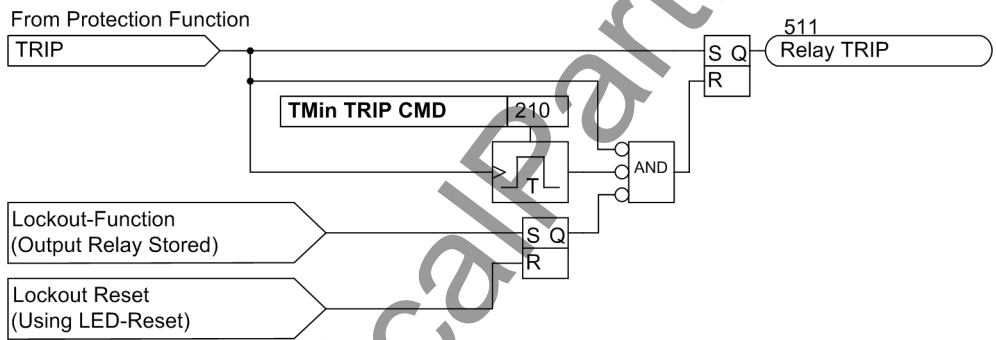

Figure 2-70 Terminating the Trip Signal

2.16.3 Setting Notes

Trip Signal Duration

The minimum trip command duration **TMin TRIP CMD** was described already in Section 2.1.3. This setting applies to all protective functions that initiate tripping.

2.17 Auxiliary Functions

The auxiliary functions of the 7SJ61 relay include:

- Message Processing
- Measurements (including acquisition of minimum and maximum values)
- Setting of Limit Values for Measured Values and Statistic Values
- Commissioning Tools

2.17.1 Message Processing

After the occurrence of a system fault, data regarding the response of the protective relay and the measured values are saved for future analysis. For this reason the device is designed to perform message processing.

Applications

- LED Display and Binary Outputs (Output Relays)
- Information via Display Field or Personal Computer
- Information to a Control Center

Prerequisites

The SIPROTEC 4 System Description provides a detailed description of the configuration procedure (see /1/).

2.17.1.1 LED Displays and Binary Outputs (Output Relays)

Important events and conditions are displayed, using LEDs at the front panel of the relay. The device furthermore has output relays for remote indication. All LEDs and binary outputs indicating specific messages can be freely configured. The relay is delivered with a default setting. The Appendix of this manual deals in detail with the delivery status and the allocation options.

The output relays and the LEDs may be operated in a latched or unlatched mode (each may be individually set).

The latched conditions are protected against loss of the auxiliary voltage. They are reset:

- On site by pressing the LED key on the relay,
- Remotely using a binary input configured for that purpose,
- Using one of the serial interfaces,
- Automatically at the beginning of a new pickup.

State indication messages should not be latched. Also, they cannot be reset until the criterion to be reported has reset. This applies to messages from monitoring functions, or similar.

A green LED displays operational readiness of the relay ("RUN"), and cannot be reset. It goes out if the self-check feature of the microprocessor recognizes an abnormal occurrence, or if the auxiliary voltage is lost.

When auxiliary voltage is present, but the relay has an internal malfunction, then the red LED ("ERROR") lights up and the processor blocks the relay.

2.17.1.2 Information on the Integrated Display (LCD) or Personal Computer

Events and conditions can be read out on the display at the front cover of the relay. Using the front PC interface or the rear service interface, a personal computer can be connected, to which the information can be sent.

The relay is equipped with several event buffers, for operational messages, circuit breaker statistics, etc., which are protected against loss of the auxiliary voltage by a buffer battery. These messages can be displayed on the LCD at any time by selection via the keypad or transferred to a personal computer via the serial service or PC interface. Readout of messages during operation is described in detail in the SIPROTEC 4 System Description.

Classification of Messages

The messages are categorized as follows:

- Operational messages (event log); messages generated while the device is operating: Information regarding the status of device functions, measured data, power system data, control command logs etc.
- Fault messages (trip log): messages from the last 8 network faults that were processed by the device.
- Ground fault messages (when the device has sensitive ground fault detection).
- Messages of "statistics"; they include a counter for the trip commands initiated by the device, maybe reclose commands as well as values of interrupted currents and accumulated fault currents.

A complete list of all message and output functions that can be generated by the device with the maximum functional scope can be found in the appendix. All functions are associated with an information number (FNo). There is also an indication of where each message can be sent to. If functions are not present in a not fully equipped version of the device, or are configured to **Disabled**, then the associated indications cannot appear.

Operational Messages (Buffer: Event Log)

The operational messages contain information that the device generates during operation and about operational conditions. Up to 200 operational messages are recorded in chronological order in the device. New messages are appended at the end of the list. If the memory is used up, then the oldest message is scrolled out of the list by a new message.

Fault Messages (Buffer: Trip Log)

After a fault on the system, for example, important information about the progression of the fault can be retrieved, such as the pickup of a protective element or the initiation of a trip signal. The start of the fault is time stamped with the absolute time of the internal system clock. The progress of the disturbance is output with a relative time referred to the instant of fault detection, so that the duration of the fault until tripping and up to reset of the trip command can be ascertained. The resolution of the time information is 1 ms

Spontaneous Messages From the Device Front

After occurrence of a fault, the most important fault data appear in the display automatically after a general pickup of the device, without further operating actions. They are displayed in the sequence shown in Figure 2-71.

50-1 PICKUP		Protective Function that Picked up First;
50-1 TRIP		Protective Function that Tripped Last;
T - Pickup	= 320 ms	Run. time from general device PU to gen. dev. drop out; (Mes.No.245)
T - TRIP	= 197 ms	Running time from general device pickup to first general device trip command; (Mes.No.246)

Figure 2-71 Display of spontaneous annunciations in the 4-line display of the device

Retrievable Messages

The messages for the last eight network faults can be retrieved and read out. The definition of a network fault is such that the time period from fault detection up to final clearing of the disturbance is considered to be one network fault. If auto-reclosing occurs, then the network fault ends after the last reclosing shot, which means after a successful reclosing or lockout. Therefore the entire clearing process, including all reclosing shots, occupies only one trip log buffer. Within a network fault, several fault messages can occur (from the first pickup of a protective function to the last dropout of a protective function). Without auto-reclosing each fault event represents a network fault.

In total 600 indications can be recorded. Oldest data are erased for newest data when the buffer is full.

General Interrogation

The general interrogation which can be retrieved via DIGSI enables the current status of the SIPROTEC 4 device to be read out. All messages requiring general interrogation are displayed with their present value.

Spontaneous Messages

The spontaneous messages displayed using DIGSI reflect the present status of incoming information. Each new incoming message appears immediately, i.e. the user does not have to wait for an update or initiate one.

2.17.1.3 Information to a Substation Control Center

If the device has a serial system interface, stored information may additionally be transferred via this interface to a centralized control and storage device. Transmission is possible via different transmission protocols.

2.17.2 Statistics

The number of trips initiated by the 7SJ61, the number of close commands initiated by the AR and the operating hours under load are counted. An additional counter allows the number of hours to be determined in which the circuit breaker is positioned in the „open“ condition. Further statistical data can be gained to optimize the intervals for circuit breaker maintenance.

Furthermore, if the device is utilized as motor protection, statistical values regarding the operation of the motor as well as the last 5 motor startups are available.

The counter and memory levels are secured against loss of auxiliary voltage.

During the first start of the protection device the statistical values are pre-defined to zero.

2.17.2.1 Description

Number of Trips

In order to count the number of trips of 7SJ61, the 7SJ61 relay has to be informed of the position of the circuit breaker auxiliary contacts via binary inputs. Hereby, it is necessary that the internal pulse counter is allocated in the matrix to a binary input that is controlled by the circuit breaker OPEN position. The pulse count value "Number of TRIPs CB" can be found in the "Statistics" group if the option "Measured and Metered Values Only" was enabled in the configuration matrix.

Number of Automatic Reclosing Commands

The number of reclosing commands initiated by the automatic reclosing function is summed up in separate counters for the 1st and ≥ 2 nd cycle.

Operating Hours

The operating hours under load are also stored (= the current value in at least one phase is greater than the limit value **BkrClosed I MIN** set under address 212).

Hours Meter "CB open"

A meter can be realized as a CFC application if it adds up the number of hours in state „Circuit Breaker open“ similarly to the operating hours meter. The universal hours meter is linked to a respective binary input and counts if the binary input is active. Alternatively, the undershooting of the parameter value 212 **BkrClosed I MIN** may be used as a criterion for starting the meter. The meter can be set or reset. A CFC application example for such meter is available on the Internet (SIPROTEC Download Area).

2.17.2.2 Circuit Breaker Maintenance

General

The procedures aiding in CB maintenance allow maintenance intervals of the CB poles to be carried out when their actual degree of wear makes it necessary. Saving on maintenance and servicing costs is one of the main benefits this functionality offers.

The universal CB maintenance accumulates the tripping currents of the trips initiated by the protective functions and comprises the four following autonomous subfunctions:

- Summation tripping current (ΣI -procedure)
- Summation of tripping powers (ΣI^x -procedure)
- Two-point procedure for calculating the remaining lifetime (2P-procedure)
- Sum of all Squared Fault Current Integral (I^2t -procedure);

Measured value acquisition and preparation operates phase-selectively for all four subfunctions. The three results are each evaluated using a threshold which is specific for each procedure (see Figure 2-72).

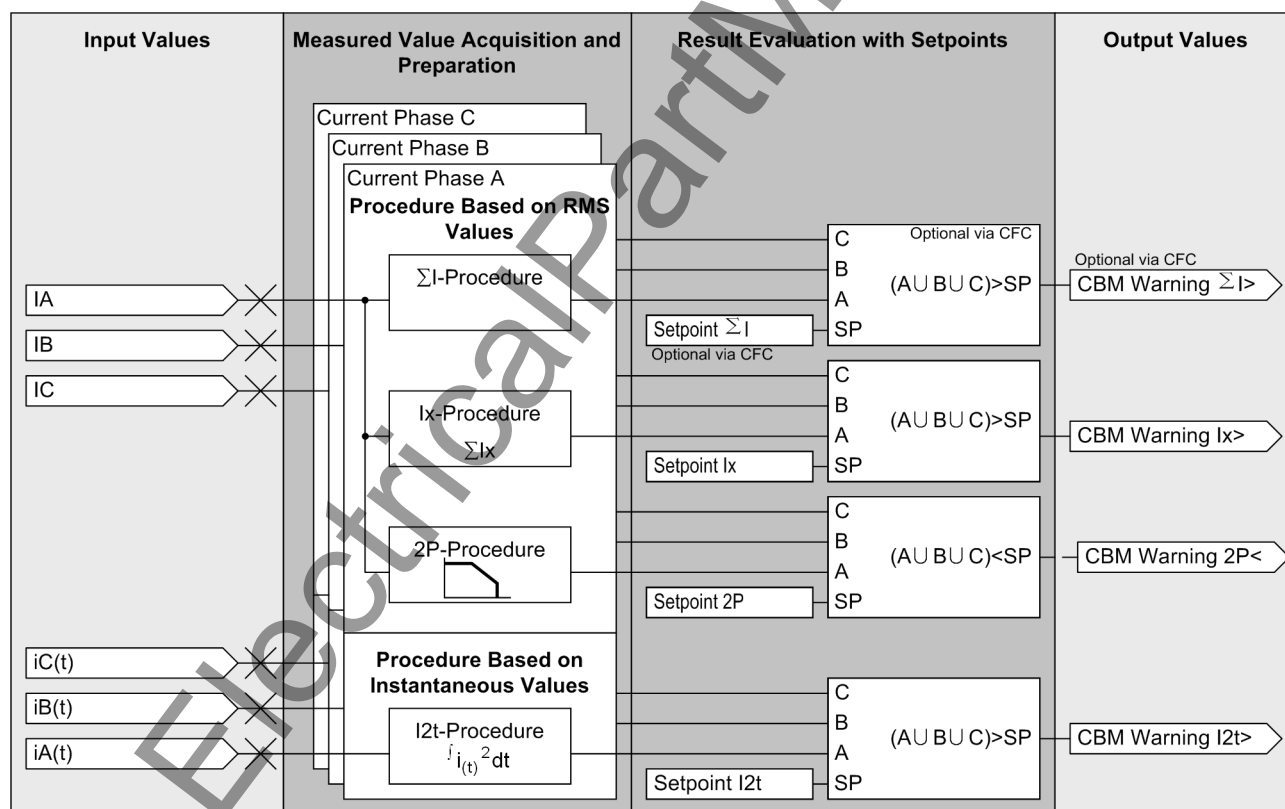

Figure 2-72 Diagram of CB maintenance procedures

The ΣI procedure is always present and active as a basic functionality. However, the other procedures (ΣI^x , 2P and I^2t) can be selected via a common configuration parameter.

As the load on the switch depends on the current amplitude and duration of the actual switching action, including arc deletion, determination of the start and end criteria is of great importance. The procedures ΣI^2 , 2P and I^2t make use of the same criteria for that purpose. The logic of the start and end criterion is illustrated in Figure 2-73.

The start criterion is fulfilled by an internal protective tripping initiated by the group indication "device TRIP". Trips initiated via the internal control function are taken into consideration for the circuit breaker maintenance if the respective command is indicated via the parameter 265 **Cmd.via control**. An externally initiated trip command can be taken into consideration if the message „>52 Wear start“ is sent simultaneously via a binary input. The edge of the sent message „>52 - a“ can also be used as a further criterion as this signals that the mechanism of the circuit breaker is put in motion in order to separate the contacts.

As soon as the start criterion has been fulfilled, the parameterized opening time of the circuit breaker is started. The time of commencement of separation of the circuit breaker contacts is thus determined. The end of the trip procedure, including arc deletion is determined via another given parameter (CB tripping time) supplied by the manufacturer of the circuit breaker.

In order to prevent an incorrect calculation procedure in case of circuit breaker failure, the current criterion 212 **BkrClosed I MIN** verifies whether the current actually returned to zero after two additional cycles. When the phase-selective logic release is fulfilled by the current criterion, the calculation and evaluation methods of the respective procedures are initiated. After these have been completed, the end criterion of the circuit breaker maintenance is fulfilled and ready for a new initiation.

Please note that CB maintenance will be blocked if parameter settings are made incorrectly. This condition is indicated by the message „52 WearSet.fail“, „52WL.blk n PErr“ or „52WL.blk I PErr“ (see Section 2.1.6.2, „Power System Data 2“). The latter two indications can only take effect if the 2P-procedure was configured.

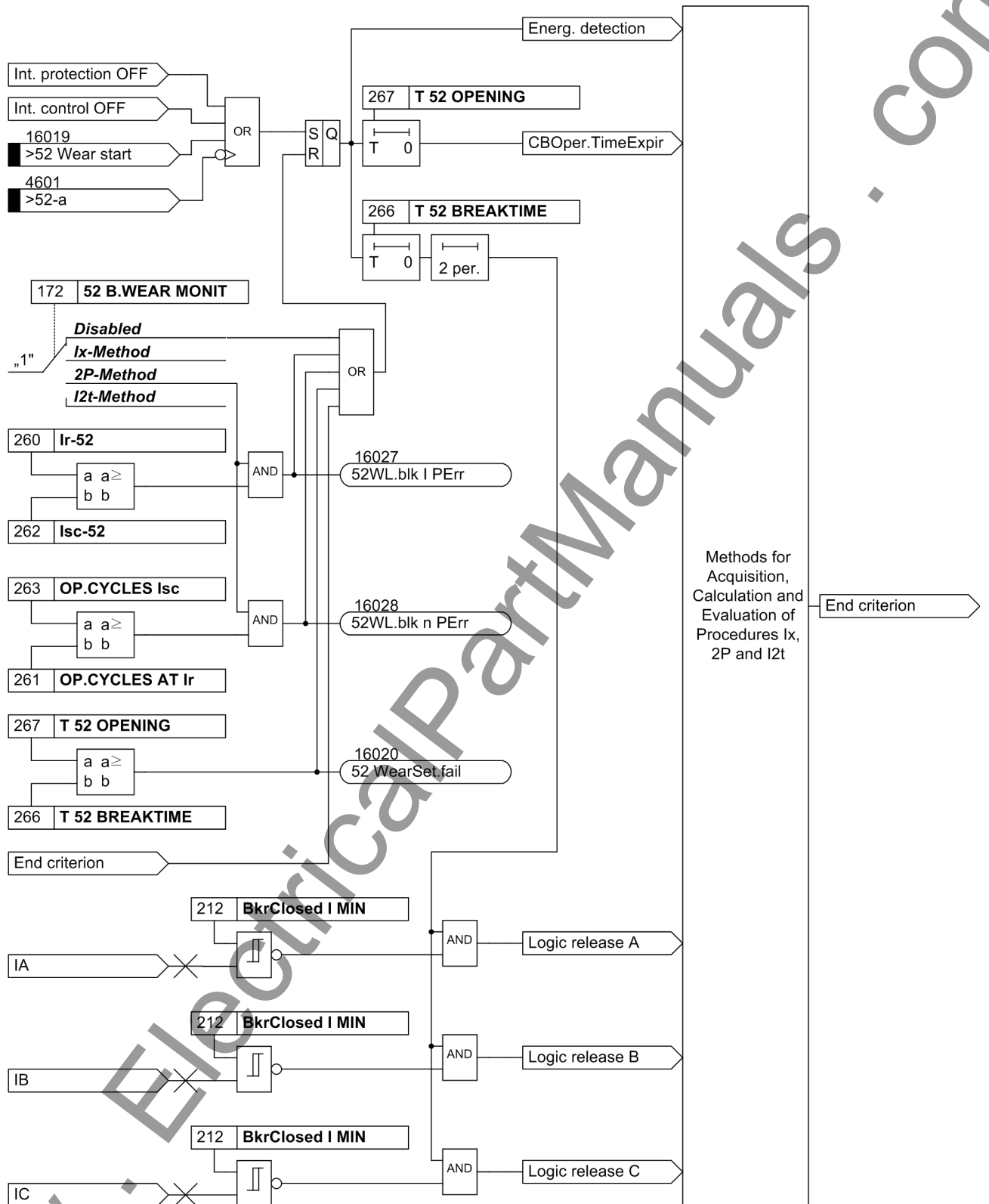

Figure 2-73 Logic of the start and end criterion

Σ I-Procedure

Being a basic function, the Σ I-procedure is unaffected by the configuration and does not require any procedure-specific settings. All tripping currents occurring $1\frac{1}{2}$ periods after a protective trip, are summed up for each phase. These tripping currents are r.m.s. values of the fundamental harmonic.

The interrupted current in each pole is determined for each trip signal. The interrupted fault current is indicated in the fault messages and is added up with previously stored fault current values in the statistic-counters. Measured values are indicated in primary terms.

The Σ I method does not feature integrated threshold evaluation. But using CFC it is possible to implement a threshold, which logically combines and evaluates the three summation currents via an OR operation. Once the summation current exceeds the threshold, a corresponding message will be triggered.

Σ I^x Procedure

While the Σ I-procedure is always enabled and active, use of the Σ I^x-procedure depends on the CB maintenance configuration. This procedure operates analogously to the Σ I-procedure. The differences relate to the involution of the tripping currents and their reference to the exponentiated rated operating current of the CB. Due to the reference to I_r^x , the result is an approximation to the number of make-break operations specified by the CB manufacturer. The displayed values can be interpreted as the number of trips at rated operational current of the CB. They are displayed in the statistics values without unit and with two decimal places.

The tripping currents used for calculation are a result of the rms values of the fundamental harmonic, which is recalculated each cycle.

If the start criterion is satisfied (as described in Section „General“), the r.m.s. values, which are relevant after expiration of the opening time, are checked for each phase as to whether they comply with the current criterion. If one of the values does not satisfy the criterion, its predecessor will be used instead for calculation. If no r.m.s. value satisfies the criterion up to the predecessor of the starting point, which is marked by the start criterion, a trip has taken place which only affects the mechanical lifetime of the breaker and is consequently not detected by this procedure.

If the current criterion grants the logic release after the opening time has elapsed, the recent primary tripping currents (I_b) are involuted and related to the exponentiated rated operating current of the CB. These values are then added to the existing statistic values of the Σ I^x-procedure. Subsequently, threshold comparison is started using threshold „ ΣI^x “ as well as the output of the new related summation tripping current powers. If one of the new statistic values lies above the threshold, the message „Threshold ΣI^x “ is generated.

2P-Procedure

The application of the two-point procedure for the calculation of the remaining lifespan depends on the CMD configuration. The data supplied by the CB manufacturer is transformed in such manner that, by means of measuring the fault currents, a concrete statement can be made with regard to the still possible operating cycles. The CB manufacturer's double-log operating cycle diagrams form the basis of the measured fault currents at the time of contact separation. Determination of the fault currents is effected in accordance with the method as described in the above section of the Σ I^x-procedure.

The three results of the calculated remaining lifetime are represented as statistic value. The results represent the number of still possible trips, if the tripping takes place when the current reaches the rated operational current. They are displayed without unit and without decimals.

As with the other procedures, a threshold logically combines the three „remaining lifetime results“ via an OR operation and evaluates them. It forms the „lower threshold“, since the remaining lifetime is decremented with each trip by the corresponding number of operating cycles. If one of the three phase values drops below the threshold, a corresponding message will be triggered.

A double-logarithmic diagram provided by the CB manufacturer illustrates the relationship of operating cycles and tripping current (see example in Figure 2-74). This diagram allows the number of yet possible trips to be determined (for tripping with equal tripping current). According to the example, approximately 1000 trips can yet be carried out at a tripping current of 10 kA. The characteristic is determined by two vertices and their connecting line. Point P1 is determined by the number of permitted operating cycles at rated operating current I_r , point P2 by the maximum number of operating cycles at rated fault tripping current I_{sc} . The associated four values can be configured.

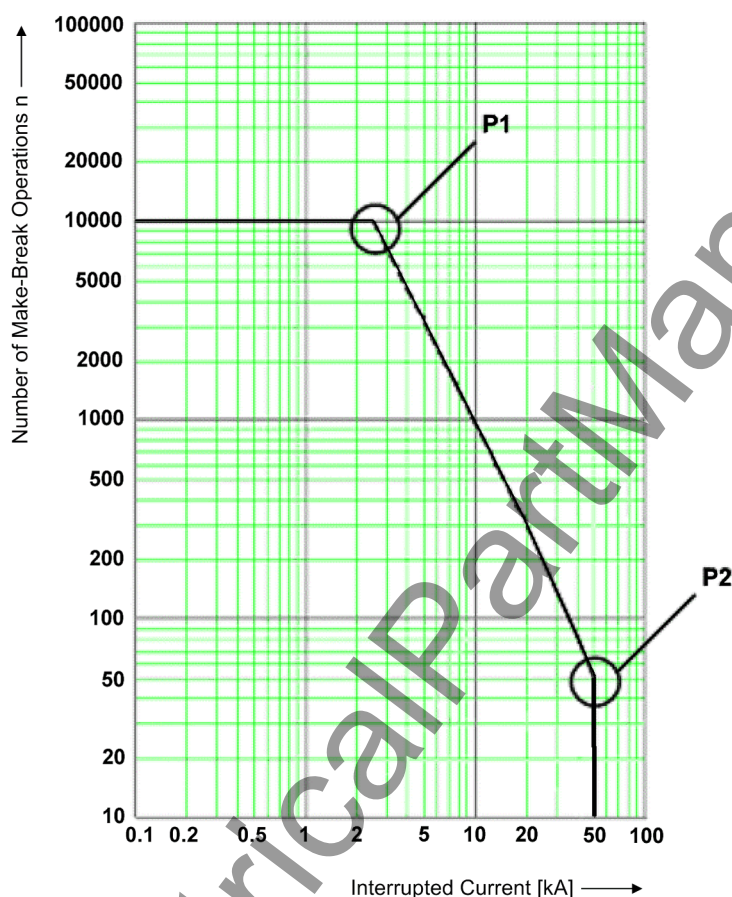

Figure 2-74 Diagram of operating cycles for the 2P procedure

As Figure 2-74 illustrates a double-log diagram, the straight line between P1 and P2 can be expressed by the following exponential function:

$$n = b \cdot I_b^m$$

where n is the number of operating cycles, b the operating cycles at $I_b = 1A$, I_b the tripping current, and m the directional coefficient.

The general line equation for the double-logarithmic representation can be derived from the exponential function and leads to the coefficients b and m .



Note

Since a directional coefficient of $m < -4$ is technically irrelevant, but could theoretically be the result of incorrect settings, it is limited to -4. If a coefficient is smaller than -4, the exponential function in the operating cycles diagram is deactivated. The maximum number of operating cycles with I_{sc} (263 **OP.CYCLES I_{sc}**) is used instead as the calculation result for the current number of operating cycles, see Figure 2-75.

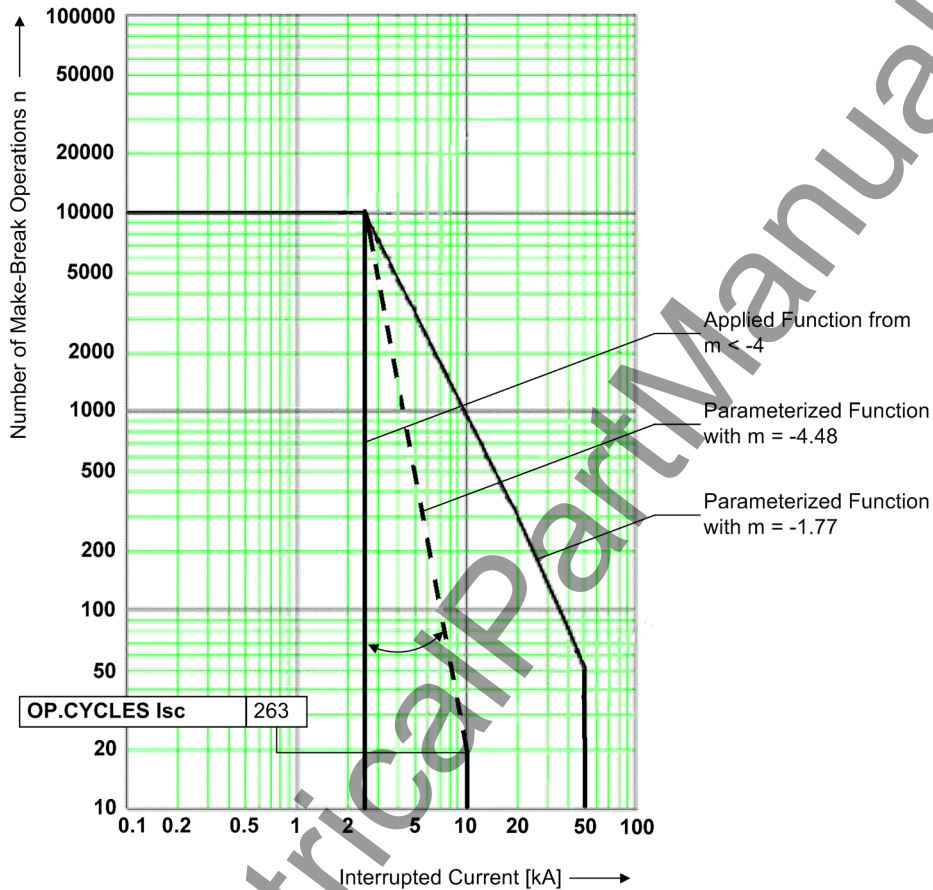

Figure 2-75 Value limitation of directional coefficient

If the current criterion described in the Section „General“ grants the phase-selective logic release, the present number of operating cycles is calculated based on the tripping currents determined when the CB operating time on tripping has elapsed. They are set off against the remaining lifetime allowing the present statistic values to be displayed and the evaluation to be started using the specified threshold. If one of the new values lies above the threshold, the message „Thresh . R . Endu . <“ is generated.

Three additional phase-selective statistic values are provided to determine the portion of purely mechanical trips among the results of the remaining lifetime (e.g. for phase A: „mechan . TRIP A=“). They act as counters which count only the trips whose tripping currents are below the value of the current criterion.

I²t-Procedure

During the I²t-procedure the squared fault current integral occurring per trip is added up phase-selectively. The integral is derived from the squared instantaneous values of the currents occurring during arc time of the circuit breaker. This results in:

$$T \text{ CB arc} = (\text{parameter } 266 \text{ T } 52 \text{ BREAKTIME}) - (\text{parameter } 267 \text{ T } 52 \text{ OPENING}).$$

The three sums of the calculated integrals are represented as statistic values referred to the squared device nominal current (I_{nom}^2). As with the other procedures, a threshold logically combines the three sums via an OR operation and evaluates them.

The calculated squared tripping current integrals are added to the existing statistic values. Subsequently, threshold comparison is started using threshold „ $\Sigma I^2 t >$ “, and the new statistic values are output. If one of the values lies above the threshold, the message „Thresh. $\Sigma I^2 t >$ “ is generated.

Commissioning

Usually, no measures are required for commissioning. However, should the protection device be exchanged (e.g. old circuit breaker and a new protection device), the initial values of the respective limit or statistical values must be determined via the switching statistics of the respective circuit breaker.

2.17.2.3 Motor Statistics

General

There are two different types of statistical motor data:

- Operational information and
- startup information.

The statistical operational information contains the

- total number of motor startups
- total number of the motor operating hours (including startup conditions)
- total number of motor shutdown hours

For every motor startup

- the duration
- the startup current

Motor Operation Information

The motor operation statistic is newly calculated in a 600 ms cycle. In the statistics buffer, its image is decreased to a resolution of one hour.

Motor Startup Information

The motor startup current is displayed as a primary value. The measurement of this statistical value is initiated upon energization of the motor. This is recognized as soon as the threshold value of the circuit breaker position detection (parameter 212 **BkrClosed I MIN**) is exceeded in at least one phase. A requirement for this is that all three phase currents were previously below the configured threshold value.

The end of the startup time measurement is triggered as soon as the largest of the three phase currents undershoots the startup current as set in parameter 1107 **I MOTOR START** for at least 300 ms.

If the motor startup current (parameter 1107 **I MOTOR START**) is not exceeded after energization detection or if the current falls below the motor startup current within 500 ms after energization detection, then this is not considered being a motor startup. No statistic is created.

2.17.2.4 Setting Notes

Reading/Setting/Resetting Counters

The SIPROTEC 4 System Description provides a description of how to read out the statistical counters via the device front panel or DIGSI. Setting or resetting of these statistical counters takes place under the menu item **MESSAGES** → **STATISTICS** by overwriting the counter values displayed.

Circuit Breaker Maintenance

Under address 172 **52 B.WEAR MONIT** one of the alternatives ΣI^x procedure, 2P procedure, I^2t procedure or **Disabled** can be set. All parameters relevant to this function are available at parameter block **P.System Data 1** (see Section 2.1.3).

The following setting values are important input values the subfunctions require in order to operate correctly:

The **CB Tripping Time** is a characteristic value provided by the manufacturer. It covers the entire tripping process from the trip command (applying auxiliary power to the trip element of the circuit breaker) up to arc extinction in all poles. The time is set at address 266 **T 52 BREAKTIME**.

The **CB Operating Time T 52 OPENING** is equally a characteristic value of the circuit breaker. It covers the time span between the trip command (applying auxiliary power to the trip element of the circuit breaker) and separation of CB contacts in all poles. It is entered at address 267 **T 52 OPENING**.

The following diagram illustrates the relationship between these CB times.

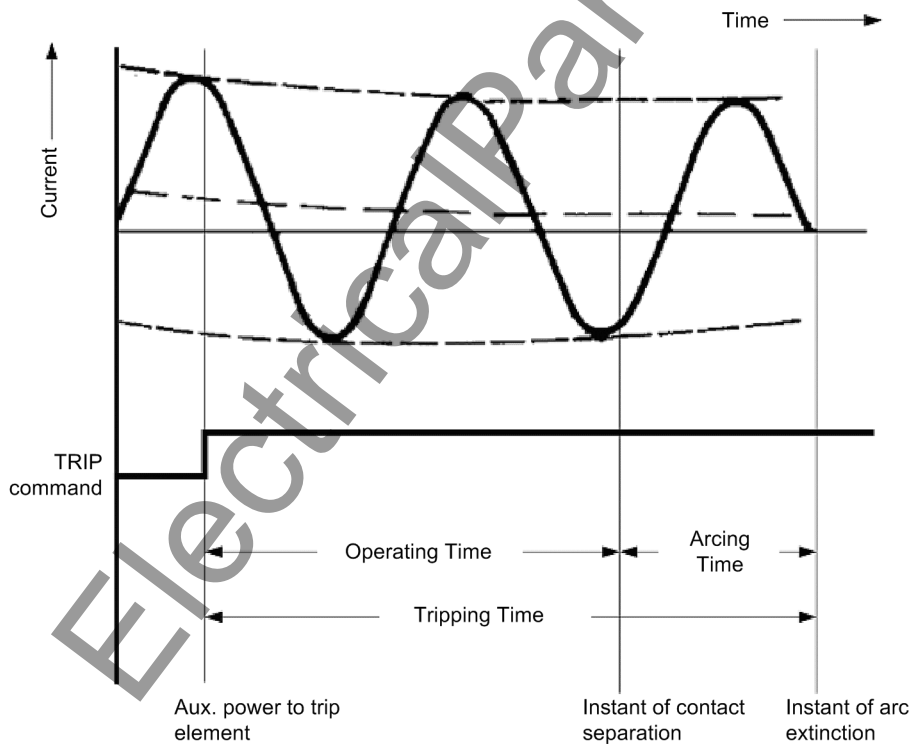

Figure 2-76 Illustration of the CB times

Current flow monitoring 212 **BkrClosed I MIN**, which some protective functions rely upon to detect a closed CB, is used as the current zero criterion. It should be set with respect to the actually used device functions (see also margin heading „Current Flow Monitoring (CB)“ in Section 2.1.3.2.

ΣI Procedure

Being the basic function of summation current formation, the ΣI -procedure is always active and does not require any additional settings. This is irrespective of the configuration in address 172 **52 B.WEAR MONIT**. This method does not offer integrated threshold evaluation. The latter could, however, be implemented using CFC.

ΣI^x Procedure

Parameter 172 **52 B.WEAR MONIT** can be set to activate the ΣI^x procedure. In order to facilitate evaluating the sum of all tripping current powers, the values are referred to the involuted CB rated operational current. This value is indicated in the CB data at address 260 **Ir-52** in the **P.System Data 1** and can be set as primary value. This reference allows the threshold of the ΣI^x procedure to correspond to the maximum number of make-break operations. For a circuit breaker, whose contacts have not yet been worn, the maximum number of make-break operations can be entered directly as threshold. The exponent for the involution of the rated operational current and of the tripping currents is set at address 264 **Ix EXPONENT**. To meet different customer requirements, this exponent **264Ix EXPONENT** can be increased from **1.0** (default setting = **2.0**) to **3.0**.

For the procedure to operate correctly, the time response of the circuit breaker must be specified in parameters 266 **T 52 BREAKTIME** and 267 **T 52 OPENING**.

The summated values can be interpreted as the number of tripping operations at rated operational current of the CB. They are displayed in the statistical values without unit and with two decimal places.

2P-Procedure

Parameter 172 **52 B.WEAR MONIT** can be set to activate the 2P procedure. An operating cycles diagram (see sample diagram in the functional description of the 2P procedure), provided by the manufacturer, shows the relationship of make-break operations and tripping current. The two vertices of this characteristic in a double logarithmic scale are decisive for the setting of addresses 260 to 263:

Point P1 is determined by the number of permitted make-break operations (parameter 261 **OP.CYCLES AT Ir**) for rated operational current I_r (parameter 260 **Ir-52**)

Point P2 is determined by the maximum number of make-break operations (parameter 263 **OP.CYCLES Isc**) for rated fault tripping current I_{sc} (parameter 262 **Isc-52**).

For the procedure to operate correctly, the time response of the circuit breaker must be specified in parameters 266 **T 52 BREAKTIME** and 267 **T 52 OPENING**.

I^2t -Procedure

The I^2t -procedure is activated via configuration parameter 172 **52 B.WEAR MONIT**. The square fault current integrals are referred to the squared device nominal current. For purposes of determining the arc time, the device must be informed of the CB tripping time **T 52 BREAKTIME** as well as the CB opening time **T 52 OPENING** of the circuit breaker. For recognition of the last zero crossing (arc deletion) of the currents after tripping, the „Current-zero“ Criterion is required.

2.17.2.5 Information List

No.	Information	Type of Information	Comments
-	#of TRIPs=	PMV	Number of TRIPs=
409	>BLOCK Op Count	SP	>BLOCK Op Counter
1020	Op.Hours=	VI	Counter of operating hours
1021	$\Sigma I_a =$	VI	Accumulation of interrupted current Ph A
1022	$\Sigma I_b =$	VI	Accumulation of interrupted current Ph B
1023	$\Sigma I_c =$	VI	Accumulation of interrupted current Ph C
2896	79 #Close1./3p=	VI	No. of 1st AR-cycle CLOSE commands,3pole
2898	79 #Close2./3p=	VI	No. of higher AR-cycle CLOSE commands,3p
10027	StartDuration1	VI	Startup Duration 1
10028	StartupCurrent1	VI	Startup Current 1
10030	Nr.of Mot.Start	VI	Total Number of Motor Starts
10031	Motor Run.Time	VI	Total Motor Running Time
10032	Motor Stop.Time	VI	Total Motor Stopped Time
10033	Perc.Run.Time	VI	Motor Percent Running Time
10037	StartDuration2	VI	Startup Duration 2
10038	StartupCurrent2	VI	Startup Current 2
10040	StartDuration3	VI	Startup Duration 3
10041	StartupCurrent3	VI	Startup Current 3
10043	StartDuration4	VI	Startup Duration 4
10044	StartupCurrent4	VI	Startup Current 4
10046	StartDuration5	VI	Startup Duration 5
10047	StartupCurrent5	VI	Startup Current 5
16001	$\Sigma I^x A=$	VI	Sum Current Exponentiation Ph A to I^x
16002	$\Sigma I^x B=$	VI	Sum Current Exponentiation Ph B to I^x
16003	$\Sigma I^x C=$	VI	Sum Current Exponentiation Ph C to I^x
16006	Resid.Endu. A=	VI	Residual Endurance Phase A
16007	Resid.Endu. B=	VI	Residual Endurance Phase B
16008	Resid.Endu. C=	VI	Residual Endurance Phase C
16011	mechan.TRIP A=	VI	Number of mechanical Trips Phase A
16012	mechan.TRIP B=	VI	Number of mechanical Trips Phase B
16013	mechan.TRIP C=	VI	Number of mechanical Trips Phase C
16014	$\Sigma I^2t A=$	VI	Sum Squared Current Integral Phase A
16015	$\Sigma I^2t B=$	VI	Sum Squared Current Integral Phase B
16016	$\Sigma I^2t C=$	VI	Sum Squared Current Integral Phase C

2.17.3 Measurement

A series of measured values and the values derived from them are constantly available for call up on site, or for data transfer.

Applications

- Information on the actual status of the system
- Conversion of secondary values to primary values and percentages

Prerequisites

Except for secondary values, the device is able to indicate the primary values and percentages of the measured values.

A precondition for correctly displaying the primary and percentage values is complete and correct entry of the nominal values for the transformers and the protected equipment as well as current transformer ratios in the ground path when configuring the device. The following table shows the formulas which are the basis for the conversion from secondary values into primary values and percentages.

2.17.3.1 Display of Measured Values

Table 2-16 Conversion formulae between secondary values and primary/percentage values

Measured Values	Secondary	Primary	%
$I_A, I_B, I_C,$ I_1, I_2	I_{sec}	$\frac{IN-CT PRIM}{IN-CT SEC} \cdot I_{sec}$	$\frac{I_{prim}}{FullScaleCurr.}$
$I_N = 3 \cdot I_0$ (calculated)	$I_{N sec}$	$\frac{IN CT PRIM}{IN CT SEC} \cdot I_{N sec}$	$\frac{I_{Nprim}}{FullScaleCurr.}$
$I_N =$ measured value of I_N input	$I_{N sec}$	$\frac{IN CT PRIM}{IN CT SEC} \cdot I_{N sec}$	$\frac{I_{Nprim}}{FullScaleCurr.}$
I_{Ns}	$I_{Ns sec.}$	$\frac{IN CT PRIM}{IN CT SEC} \cdot I_{Ns sec}$	$\frac{I_{Ns prim}}{FullScaleCurr.}$

Table 2-17 Legend for the conversion formulae

Parameters	Address	Parameter	Address
CT PRIMARY	204	Ignd-CT PRIM	217
CT SECONDARY	205	Ignd-CT SEC	218
		FullScaleCurr.	1102

Depending on the type of device ordered and the device connections, some of the operating measured values listed below may not be available. The ground current I_N is either measured directly or calculated from the conductor currents.

$$I_N = \frac{3 \cdot I_0}{I_{\text{gnd-CT}} / (CT)}$$

with $3I_0 = (I_A + I_B + I_C)$
 $I_{\text{gnd-CT}} = \text{setting 0217 or 0218}$
 $CT = \text{setting 0204 or 0205}$

In addition, the following may be available:

- $\Theta/\Theta_{\text{Trip}}$ **thermal measured value** of overload protection value for stator in % of the trip initiating overtemperature
- $\Theta/\Theta_{\text{LTrip}}$ **thermal measured value** of restart inhibit (rotor winding)
- Θ_{Restart} **restarting limit** of restart inhibit
- T_{Reclose} **total time**, before the motor can be restarted
- $\Theta_{\text{RTD 1}}$ to $\Theta_{\text{RTD 12}}$ **temperature values** at the RTD-boxes.

The operational measured values are also calculated during a running fault. The values are updated in intervals of > 0.3 s and < 1 s.

2.17.3.2 Transfer of Measured Values

Measured values can be transferred via the interfaces to a central control and storage unit.

The measuring range in which these values are transmitted depend on the protocol and, if necessary, additional settings.

Protocol	Transmittable measuring range, format
IEC 60870-5-103	0 to 240 % of the measured value.
IEC 61850	The primary operational measured values are transmitted. The measured values as well as their unit format are set out in detail in manual PIXIT 7SJ. The measured values are transmitted in „Float“ format. The transmitted measuring range is not limited and corresponds to the operational measurement.
PROFIBUS, Modbus, DNP 3.0	The unit format of the measured values on the device side is at first automatically generated by means of the selected nominal current value within the system data. The current unit format can be determined in DIGSI or at the device via Menu Operational Values. The user can select via DIGSI which operational measured values (primary, secondary or percentage) must be transmitted. The measured values are always transmitted as 16-bit values including sign (range ± 32768). The user can define the scaling of the operational measured value to be transmitted. This will result in the respective transmittable measuring range. For further details, please refer to the descriptions and protocol profiles.

2.17.3.3 Information List

No.	Information	Type of Information	Comments
601	Ia =	MV	Ia
602	Ib =	MV	Ib
603	Ic =	MV	Ic
604	In =	MV	In
605	I1 =	MV	I1 (positive sequence)
606	I2 =	MV	I2 (negative sequence)
661	⊖ REST. =	MV	Threshold of Restart Inhibit
805	⊖ Rotor	MV	Temperature of Rotor
807	⊖/⊖trip	MV	Thermal Overload
809	T reclose=	MV	Time until release of reclose-blocking
830	INs =	MV	INs Sensitive Ground Fault Current
831	3I0 =	MV	3I0 (zero sequence)
1068	⊖ RTD 1 =	MV	Temperature of RTD 1
1069	⊖ RTD 2 =	MV	Temperature of RTD 2
1070	⊖ RTD 3 =	MV	Temperature of RTD 3
1071	⊖ RTD 4 =	MV	Temperature of RTD 4
1072	⊖ RTD 5 =	MV	Temperature of RTD 5
1073	⊖ RTD 6 =	MV	Temperature of RTD 6
1074	⊖ RTD 7 =	MV	Temperature of RTD 7
1075	⊖ RTD 8 =	MV	Temperature of RTD 8
1076	⊖ RTD 9 =	MV	Temperature of RTD 9
1077	⊖ RTD10 =	MV	Temperature of RTD10
1078	⊖ RTD11 =	MV	Temperature of RTD11
1079	⊖ RTD12 =	MV	Temperature of RTD12
16032	In2 =	MV	In2

2.17.4 Average Measurements

The long-term averages are calculated and output by the 7SJ61.

2.17.4.1 Description

Long-Term Averages

The long-term averages of the three phase currents I_x , and the positive sequence components I_1 for the three phase currents are calculated within a set period of time and indicated in primary values.

For the long-term average values mentioned above, the length of the time window for averaging and the frequency with which it is updated can be set.

2.17.4.2 Setting Notes

Average Calculation

The selection of the time period for measured value averaging is set with parameter 8301 **DMD Interval** in the corresponding setting group from A to D under **MEASUREMENT**. The first number specifies the averaging time window in minutes while the second number gives the frequency of updates within the time window. **15 Min., 3 Subs**, for example, means: Time average is generated for all measured values with a window of 15 minutes. The output is updated every $15/3 = 5$ minutes.

With address 8302 **DMD Sync. Time**, the starting time for the averaging window set under address 8301 is determined. This setting specifies if the window should start on the hour (**On The Hour**) or 15 minutes later (**15 After Hour**) or 30 minutes / 45 minutes after the hour (**30 After Hour**, **45 After Hour**).

If the settings for averaging are changed, then the measured values stored in the buffer are deleted, and new results for the average calculation are only available after the set time period has passed.

2.17.4.3 Settings

Addr.	Parameter	Setting Options	Default Setting	Comments
8301	DMD Interval	15 Min., 1 Sub 15 Min., 3 Subs 15 Min., 15 Subs 30 Min., 1 Sub 60 Min., 1 Sub 60 Min., 10 Subs 5 Min., 5 Subs	60 Min., 1 Sub	Demand Calculation Intervals
8302	DMD Sync. Time	On The Hour 15 After Hour 30 After Hour 45 After Hour	On The Hour	Demand Synchronization Time

2.17.4.4 Information List

No.	Information	Type of Information	Comments
833	I1 dmd=	MV	I1 (positive sequence) Demand
963	Ia dmd=	MV	I A demand
964	Ib dmd=	MV	I B demand
965	Ic dmd=	MV	I C demand

2.17.5 Min/Max Measurement Setup

Minimum and maximum values are calculated by the 7SJ61. Time and date of the last update of the values can also be read out.

2.17.5.1 Description

Minimum and Maximum Values

The minimum and maximum values of the three phase currents I_A , I_B , I_C , the positive sequence components I_1 and the thermal measured value of overload protection Θ/Θ_{Trip} are calculated as primary values including the date and time they were last updated.

The minimum and maximum values of the long-term mean values listed in the previous section are also calculated.

The min/max values can be reset via binary inputs, via DIGSI or via the integrated control panel at any time. In addition, the reset can also take place cyclically, beginning with a pre-selected point in time.

2.17.5.2 Setting Notes

Minimum and Maximum Values

The tracking of minimum and maximum values can be reset automatically at a programmable point in time. To select this feature, address 8311 **MinMax cycRESET** should be set to **YES**. The point in time when reset is to take place (the minute of the day in which reset will take place) is set at address 8312 **MiMa RESET TIME**. The reset cycle in days is entered at address 8313 **MiMa RESETCYCLE**, and the beginning date of the cyclical process, from the time of the setting procedure (in days), is entered at address 8314 **MinMaxRES.START**.

2.17.5.3 Settings

Addr.	Parameter	Setting Options	Default Setting	Comments
8311	MinMax cycRESET	NO YES	YES	Automatic Cyclic Reset Function
8312	MiMa RESET TIME	0 .. 1439 min	0 min	MinMax Reset Timer
8313	MiMa RESETCYCLE	1 .. 365 Days	7 Days	MinMax Reset Cycle Period
8314	MinMaxRES.START	1 .. 365 Days	1 Days	MinMax Start Reset Cycle in

2.17.5.4 Information List

No.	Information	Type of Information	Comments
-	ResMinMax	IntSP_Ev	Reset Minimum and Maximum counter
395	>I MinMax Reset	SP	>I MIN/MAX Buffer Reset
396	>I1 MiMaReset	SP	>I1 MIN/MAX Buffer Reset
403	>Idmd MiMaReset	SP	>Idmd MIN/MAX Buffer Reset
412	> Θ MiMa Reset	SP	>Theta MIN/MAX Buffer Reset
837	IAdmdMin	MVT	I A Demand Minimum
838	IAdmdMax	MVT	I A Demand Maximum
839	IBdmdMin	MVT	I B Demand Minimum
840	IBdmdMax	MVT	I B Demand Maximum
841	ICdmdMin	MVT	I C Demand Minimum
842	ICdmdMax	MVT	I C Demand Maximum
843	I1dmdMin	MVT	I1 (positive sequence) Demand Minimum
844	I1dmdMax	MVT	I1 (positive sequence) Demand Maximum
851	Ia Min=	MVT	Ia Min
852	Ia Max=	MVT	Ia Max
853	Ib Min=	MVT	Ib Min
854	Ib Max=	MVT	Ib Max
855	Ic Min=	MVT	Ic Min
856	Ic Max=	MVT	Ic Max
857	I1 Min=	MVT	I1 (positive sequence) Minimum
858	I1 Max=	MVT	I1 (positive sequence) Maximum
1058	Θ/Θ TrpMax=	MVT	Overload Meter Max
1059	Θ/Θ TrpMin=	MVT	Overload Meter Min

2.17.6 Set Points for Measured Values

SIPROTEC devices facilitate the setting of limit values for any measured or metered values. Should any of these setpoints be reached, exceeded or undershot during operation, the device issues a warning which is indicated in the form of an operational message. This message can be configured to LEDs and/or binary outputs, transferred via the ports and interconnected in DIGSI CFC. In addition you can use DIGSI CFC to configure set points for further measured and metered values and allocate these via the DIGSI device matrix. In contrast to the actual protection functions the limit value monitoring function operates in the background; therefore it may not pick up if measured values are changed spontaneously in the event of a fault and if protection functions are picked up. As a message is only issued upon multiple exceeding of the limit values, such limit value monitoring does not react as fast as the trip signals of protection functions.

Applications

- This monitoring program works with multiple measurement repetitions and lower priority than the protection functions. For that reason, in the event of a fault it may not respond to fast measured value changes before protection functions are started and tripped. This monitoring program is not suitable for blocking protection functions.

2.17.6.1 Description

Limit Value Monitoring

Ex works, the following individual limit value levels are configured:

- IAdmd>: Exceeding a preset maximum average value in Phase A.
- IBdmd>: Exceeding a preset maximum average value in Phase B.
- ICdmd>: Exceeding a preset maximum average value in Phase C.
- I1dmd>: Exceeding a preset maximum average positive sequence current.
- IL<: Falling below a preset current in any phase.

2.17.6.2 Setting Notes

Setpoints for Measured Values

Setting is performed in the DIGSI Configuration Matrix under **Settings, Masking I/O (Configuration Matrix)**. Set the filter "Measured and Metered Values Only" and select the configuration group "Setpoints (LV)". Here, default settings may be changed or new setpoints defined.

Settings must be applied in percent and usually refer to nominal values of the device.

2.17.6.3 Information List

No.	Information	Type of Information	Comments
-	I Admd>	LV	I A dmd>
-	I Bdmd>	LV	I B dmd>
-	I Cdmd>	LV	I C dmd>
-	I1dmd>	LV	I1dmd>
-	37-1	LV	37-1 under current
273	SP. I A dmd>	OUT	Set Point Phase A dmd>
274	SP. I B dmd>	OUT	Set Point Phase B dmd>
275	SP. I C dmd>	OUT	Set Point Phase C dmd>
276	SP. I1dmd>	OUT	Set Point positive sequence I1dmd>
284	SP. 37-1 alarm	OUT	Set Point 37-1 Undercurrent alarm

2.17.7 Set Points for Statistic

2.17.7.1 Description

For the statistical counters, limit values may be entered and a message is generated as soon as they are reached. The message can be allocated to both output relays and LEDs.

2.17.7.2 Setting Notes

Setpoints for statistics counters

Setpoints for the statistic counter are entered in the DIGSI® menu item **Annunciation** → **Statistic** into the submenu **Setpoints for Statistic**. Double-click to display the corresponding contents in another window. By overwriting the previous value you can change the settings (please refer to the SIPROTEC® 4 System Description).

2.17.7.3 Information List

No.	Information	Type of Information	Comments
-	OpHour>	LV	Operating hours greater than
272	SP. Op Hours>	OUT	Set Point Operating Hours
16004	$\Sigma I^x >$	LV	Threshold Sum Current Exponentiation
16005	Threshold $\Sigma I^x >$	OUT	Threshold Sum Curr. Exponent. exceeded
16009	Resid.Endu. <	LV	Lower Threshold of CB Residual Endurance
16010	Thresh.R.Endu.<	OUT	Dropped below Threshold CB Res.Endurance
16017	$\Sigma I^2 t >$	LV	Threshold Sum Squared Current Integral
16018	Thresh. $\Sigma I^2 t >$	OUT	Threshold Sum Squa. Curr. Int. exceeded

2.17.8 Commissioning Aids

Device data sent to a central or master computer system during test mode or commissioning can be influenced. There are tools for testing the system interface and the binary inputs and outputs of the device.

Applications

- Test Mode
- Commissioning

Prerequisites

The following applies to the utilization of the commissioning aids as described below:

The device must be equipped with an interface.

The device has to be connected to a control center.

2.17.8.1 Description

Test Messages to the SCADA Interface during Test Operation

If the device is connected to a central or main computer system via the SCADA interface, then the information that is transmitted can be influenced.

Depending on the type of protocol, all messages and measured values transferred to the central control system can be identified with an added message "test operation"-bit while the device is being tested on site (test mode). This identification prevents the messages from being incorrectly interpreted as resulting from an actual power system disturbance or event. As another option, all messages and measured values normally transferred via the system interface can be blocked during the testing ("block data transmission").

Data transmission block can be accomplished by controlling binary inputs, by using the operating panel on the device, or with a PC and DIGSI via the operator interface.

The SIPROTEC 4 System Manual describes in detail how to activate and deactivate test mode and blocked data transmission.

Checking the System Interface

If the device features a system interface and uses it to communicate with the control center, the DIGSI device operation can be used to test if messages are transmitted correctly.

A dialog box shows the display texts of all messages which were allocated to the system interface in the configuration matrix. In another column of the dialog box you can specify a value for the messages you intend to test (e.g. ON/OFF). After having entered password no. 6 (for hardware test menus) a message can be generated. The corresponding message is issued and can be read out either from the event log of the SIPROTEC 4 device or from the substation control system.

The procedure is described in detail in Chapter "Mounting and Commissioning".

Checking the Binary Inputs and Outputs

The binary inputs, outputs, and LEDs of a SIPROTEC 4 device can be individually and precisely controlled in DIGSI. This feature can be used, for example, to verify control wiring from the device to substation equipment (operational checks), during start-up.

A dialog box shows all binary inputs and outputs as well as LEDs of the device with their present status. The operating equipment, commands, or messages that are configured (masked) to the hardware components are also displayed. After having entered password no. 6 (for hardware test menus), it is possible to switch to the opposite status in another column of the dialog box. Thus, you can energize every single output relay to check the wiring between protected device and the system without having to create the alarm allocated to it.

The procedure is described in detail in Chapter "Mounting and Commissioning".

Creating Oscillographic Recordings for Tests

During commissioning, energization sequences should be carried out to check the stability of the protection also during closing operations. Oscillographic event recordings contain the maximum information on the behavior of the protection.

Along with the capability of storing fault recordings via pickup of the protection function, the 7SJ61 also has the capability of capturing the same data when commands are given to the device via the service program DIGSI, the serial interface, or a binary input. For the latter, event „>Trig.Wave.Cap.“ must be allocated to a binary input. Triggering for the oscillographic recording then occurs, for instance, via the binary input when the protection object is energized.

An oscillographic recording that is triggered externally (that is, without a protective element pickup) are processed by the device as a normal oscillographic record. For each oscillographic record a fault record is created which is given its individual number to ensure that assignment can be made properly. However, these oscillographic recordings are not displayed in the fault log buffer in the display as they are no network fault events.

The procedure is described in detail in Chapter "Mounting and Commissioning".

2.17.9 Web Monitor

The Web Monitor facilitates the display of parameters, data and measuring values for SIPROTEC 4 devices during installation or during operation. It uses Internet technology for this purpose. The display is effected by means of a Web browser, e.g. the Internet Explorer.

The SIPROTEC Web Monitor provides a variety of comprehensive device functions, other available functions are device-specific. For the 7SJ61 a phase diagram is implemented as specific function. Apart from general information regarding installation, this manual provides a description of specific functions of the SIPROTEC Web Monitor for 7SJ61 only. The general functions are described in the Help file of the DIGSI-CD (as from DIGSI V4.60).

Prerequisites

The Web Monitor runs on the operator PC and requires only standard software. The following software programs / operating systems must be installed:

Operating system: Microsoft Windows XP, Microsoft Windows 2000, Microsoft Windows NT, Microsoft Windows ME, Microsoft Windows 98

Internet browser: Netscape Communicator Version 4.7, Netscape Communicator as from Version 6.x or Microsoft Internet Explorer as from Version 5.0. Java must be installed and activated.

Long-distance data transmission network: The required software component is included in Microsoft Windows XP, Microsoft Windows 2000, Microsoft Windows NT and Windows 98. This component is only required if the device is connected via a serial interface.

Network adapter: The required software component is included in Microsoft Windows XP, Microsoft Windows 2000, Microsoft Windows NT and Windows 98. This component is only required if the device is connected via a serial interface (possible for devices with EN 100 interface).

2.17.9.1 General

During the commissioning phase, the device configuration created in the devices must be verified and their functions be checked. The Web Monitor provides support during the basic and clear determination and displaying of important measuring values.

Discrepancies in the wiring or the configuration can be quickly found and solved.

To run the Web Monitor, a link from the operator PC to the protection device via its front and rear operator interface (service interface) is necessary. This can be done directly via the 9-pole DIGSI cable by means of an existing long-distance data connection. Remote access via a modem is also possible. An Internet browser must be installed on the operator PC (see paragraph on system requirements). DIGSI 4 is usually also installed on the operator PC.

Please note that it must be ensured that DIGSI 4 and the Web Monitor do not use the same operator interface at the same time. A simultaneous serial access would lead to data collisions. This means that either DIGSI 4 OR the Web-Monitor can use a device interface. Before the Web Monitor is started, DIGSI 4 must be exited or at least the settings and allocations in DIGSI 4 must have been finalized. It is possible to simultaneously operate DIGSI 4 at the front operator interface via a COM port of the operator PC and the Web Monitor at the rear operating interface via another COM port of the operating PC.

The Web Monitor consists of HTML pages and the Java-Applets contained therein, which are stored in the 7SJ61 SIPROTEC 4 device in EEPROM. It forms an integral part of the SIPROTEC 4 device firmware and therefore does not need to be installed separately. All that needs to be created on the operator PC is a long-distance data transmission network used for selection and communication. After the link has been successfully established through the data transmission network, the browser is started and the TCP-IP address of the protection device is entered. The server address of the device, which is its homepage address, is transmitted to the browser and displayed as an HTML page. This TCP-IP address is set at the front and service interface using DIGSI 4, or directly on the device using the integrated operator interface.

**Note**

It is only possible to monitor this process. Control of the process through the data transmission link is only possible after a control feature has been set up and established. A parameter can be modified either directly on the device or with DIGSI 4 in such manner that the device control feature contained in the Web Monitor also permits the input of numerical values. Thereafter, the Web Monitor parameters can be modified which are normally set only directly on the device, because passwords can now be entered from the keyboard.

2.17.9.2 Functions

Basic Functionality

Basic functionality means the functions that are generally available, i.e. not device-dependent.

These comprise:

- Device Control
- Messages
- Fault Records
- Measurement Overview
- Diagnostics
- Device File System
- CFC

A description of these functions is provided in the Online Help of DIGSI as from Version V4.60.

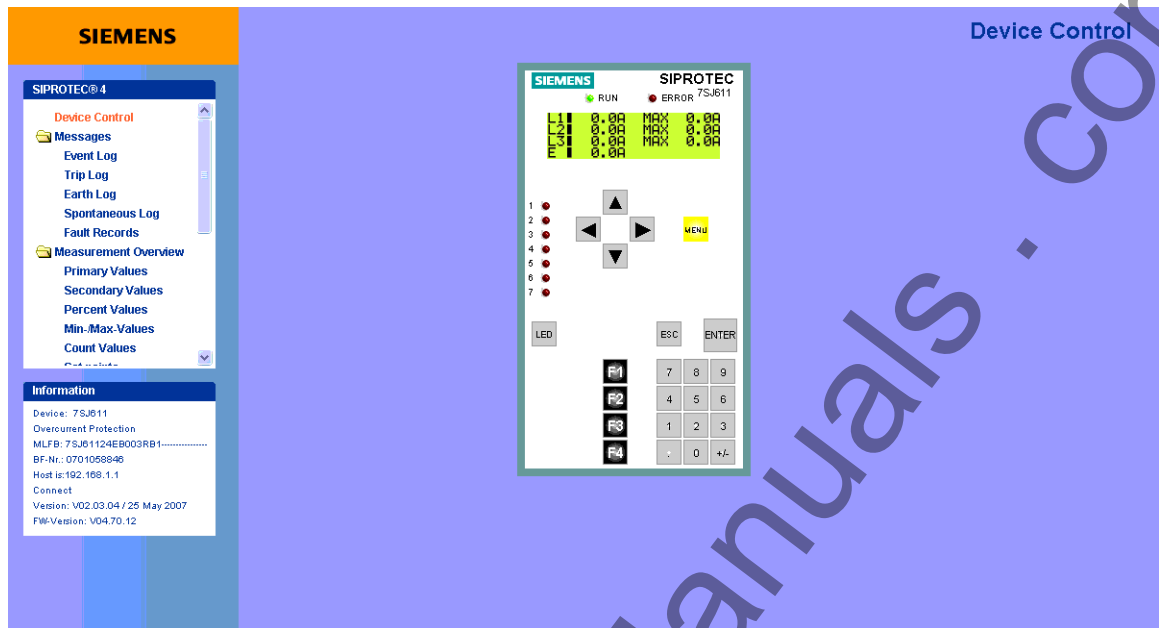

Figure 2-77 Web Monitor - Default display

The above figure of the device operation view shows a device connected through the data transmission link with its control (keyboard) and display elements (display, LEDs, inscriptions). The device can be operated with the keys shown in the display in the same way as with the sealed keypad on the device.

It is recommended to block the control via the Web Monitor. This can also be achieved by setting "Read Only"-access for the interface via which the Web browser accesses the device. This parameter can be accessed in DIGSI via "Interfaces - Operator Interface on Device" (for access via serial interface) or via "Interfaces - Ethernet on Device" (for access via the Ethernet interface, see the following figure).

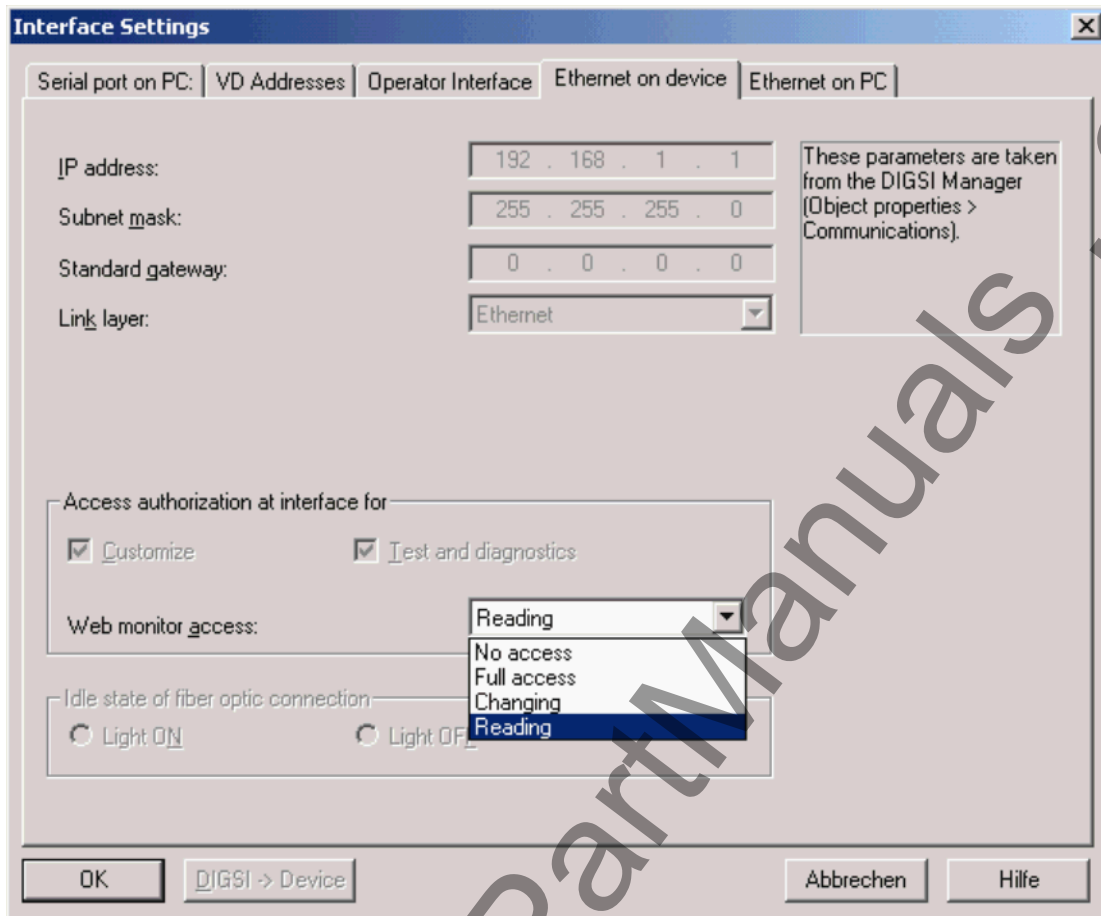

Figure 2-78 Setting the Web Monitor authorization for acces via Ethernet interface

As an example for the basic functionality, the figure below shows messages of the event log of the device in the form of a list. These messages are displayed with their short text stored in the device.

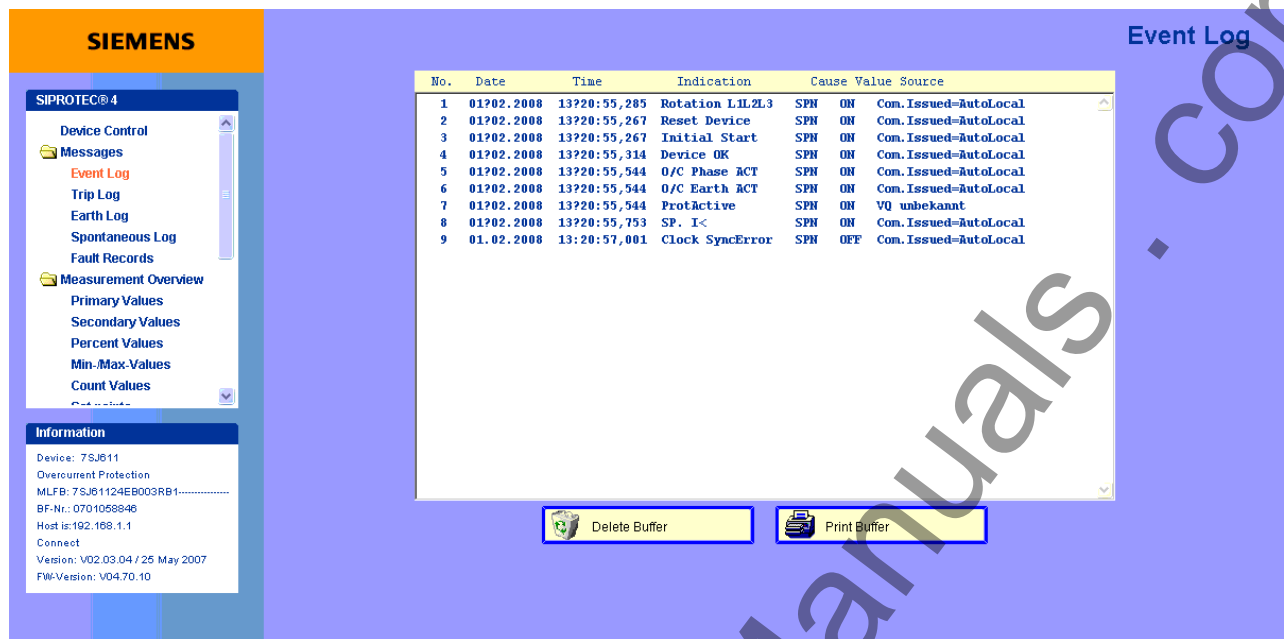

Figure 2-79 Web Monitor — examples for operational messages

2.17.9.3 Operating Modes

The Web Monitor works in the following operating modes between the operator PC and the SIPROTEC 4 device:

Direct Serial Connection

Direct connection of the front operator interface or the rear service interface of the device with the serial interface of the operator PC. For this link the 9-pin cable must be used that is supplied as an accessory with DIGSI.

Optional Connection via Modem

Serial connection of the rear service interface of the device with a modem in the system. This connection can be electrically implemented via RS232 (over short distance) or via fiber optics. The connection to the system modem is established from the office or from any other system using a switched line. DIGSI-Remote can also be carried out using this connection. Thus, parameters of a remote device can also be changed during the installation.

Operation with Star Coupler

Connection of the rear service interface of the device via a direct optical connection to a star coupler. Connection of the operator PC's serial interface to a star coupler. In this way several devices can be operated within the system; the existing installation can be used for central operation of protection devices.

Operation via Ethernet

Connection via an Ethernet interface. This type of connection requires an EN100 communication module inside the device and a connection of that module to a local network.

For more information of the basic functionality, the installation and the operating system-specific configuration, please refer to the Web-Monitor online help provided on the DIGSI CD.

Access Regulations for Web Monitor

The access rights for the Web Monitor are assigned with DIGSI via the **Interfaces** entry. It is recommended to assign the **Read only** authority there; it is then not possible to delete the event list via the Web Monitor nor to issue a command or to reset a stored LED. If the **Full access** is assigned, all these operating actions are also possible via the Web Monitor.



Note

No access has no effect yet, i.e. the user also has full access in this case. See Figure 2-78 on that.

2.17.9.4 Display Example

With the help of the Web Monitor, a clear representation of the most important measurement data of the device can be achieved. The measurement values can be called via the navigation bar. A list with the desired information appears (see Figure 2-80).

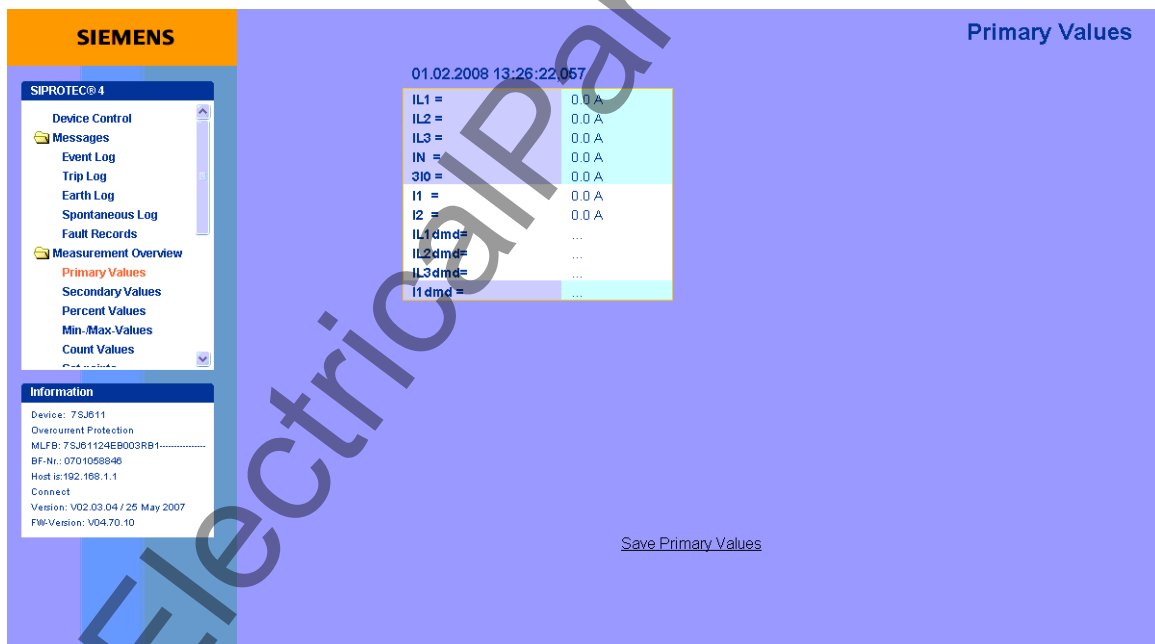

Figure 2-80 Web Monitor — examples for measured variables

The currents and their phase angles derived from the primary and secondary measured values are graphically displayed as phasor diagrams (see Figure 2-81). In addition to phasor diagrams of the measured values, the numerical values as well as frequency and device address are indicated.

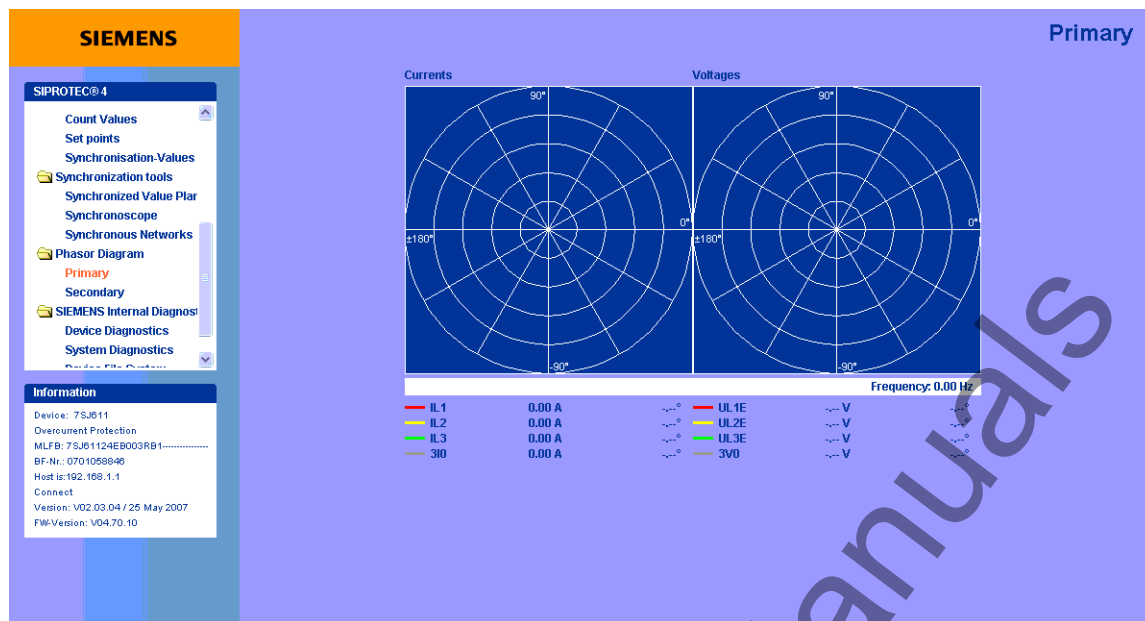

Figure 2-81 Web-Monitor — example of phasor diagram of the primary measured values

The following types of messages can be retrieved and displayed with the Web Monitor.

- Operational messages (buffer: event log),
- Fault messages (buffer: trip log),
- Ground fault messages,
- Spontaneous messages.

You can print these lists with the „Print event buffer“ button.

2.17.9.5 Setting Notes

The parameters for the Web Monitor can be set separately via the device menu (Setup/Options/IP Configuration) or via DIGSI for the front operator interface and for the rear service interface. These are IP addresses related to the interface via which communication with the PC and the Web monitor is to be performed.

The IP addresses apply to SIPROTEC for the following operations via the

- front operator interface: 192.168.1.1
- rear service interface: 192.168.2.1

If the device has an EN100 module, operation via the system interface is also possible. In this case, the IP address is automatically drawn from the system or individually assigned via the station configurator.

Ensure that the 12-digit IP address valid for the browser is set correctly via DIGSI or the device display in the format `***.***.***.***`.

2.18 Breaker Control

A control command process is integrated in the SIPROTEC 4 device 7SJ61 to coordinate the operation of circuit breakers and other equipment in the power system.

Control commands can originate from four command sources:

- Local operation using the keypad of the device (except for variant without operator panel)
- Operation using DIGSI
- Remote operation via network control center or substation controller (e.g. SICAM)
- Automatic functions (e.g., using a binary input)

Switchgear with single and multiple busbars are supported. The number of switchgear devices to be controlled is, basically, limited by the number of binary inputs and outputs present. High security against inadvertent device operations can be ensured if interlocking checks are enabled. A standard set of optional interlocking checks is provided for each command issued to circuit breakers/switchgear.

2.18.1 Control Device

Switchgear can be controlled via the device operator panel, via the operating port using a personal computer and via the serial port with a link to the substation control equipment.

Applications

- Switchgears with single and double busbars

Prerequisites

The number of switchgear devices to be controlled is limited by the

- binary inputs present
- binary outputs present

2.18.1.1 Description

Operation Using the Integrated Operator Panel

Using the navigation keys ▲, ▼, ◀, ▶, the control menu can be accessed and the switching device to be operated can be selected. After having entered a password, a new window is displayed in which multiple control actions (e.g. close, open, cancel) are available and can be selected using the ▼ and ▲ keys. Thereafter, a query appears for security reasons. After the security check has been completed, the ENTER key must be pressed again to carry out the command. If this release does not occur within one minute, the process is aborted. Cancellation via the Esc key is possible at any time before the control command is issued.

Operation using DIGSI

Switchgear devices can be controlled via the operator control interface with a PC using the DIGSI operating program. The procedure to do so is described in the SIPROTEC 4 System Description (Control of Switchgear).

Operation Using the System Interface

Control of switching devices can be performed via the serial system interface and a connection to the switch-gear control and protection system. It is therefore required to ensure that the required peripherals physically exist in the device and in the power system. Furthermore, certain settings for the serial interface in the device need to be carried out (see SIPROTEC 4 System Description).

2.18.1.2 Information List

No.	Information	Type of Information	Comments
-	52Breaker	CF_D12	52 Breaker
-	52Breaker	DP	52 Breaker
-	Disc.Swit.	CF_D2	Disconnect Switch
-	Disc.Swit.	DP	Disconnect Switch
-	GndSwit.	CF_D2	Ground Switch
-	GndSwit.	DP	Ground Switch
-	52 Open	IntSP	Interlocking: 52 Open
-	52 Close	IntSP	Interlocking: 52 Close
-	Disc.Open	IntSP	Interlocking: Disconnect switch Open
-	Disc.Close	IntSP	Interlocking: Disconnect switch Close
-	GndSw Open	IntSP	Interlocking: Ground switch Open
-	GndSw Cl.	IntSP	Interlocking: Ground switch Close
-	UnlockDT	IntSP	Unlock data transmission via BI
-	Q2 Op/Cl	CF_D2	Q2 Open/Close
-	Q2 Op/Cl	DP	Q2 Open/Close
-	Q9 Op/Cl	CF_D2	Q9 Open/Close
-	Q9 Op/Cl	DP	Q9 Open/Close
-	Fan ON/OFF	CF_D2	Fan ON/OFF
-	Fan ON/OFF	DP	Fan ON/OFF
31000	Q0 OpCnt=	VI	Q0 operationcounter=
31001	Q1 OpCnt=	VI	Q1 operationcounter=
31002	Q2 OpCnt=	VI	Q2 operationcounter=
31008	Q8 OpCnt=	VI	Q8 operationcounter=
31009	Q9 OpCnt=	VI	Q9 operationcounter=

2.18.2 Types of Commands

In conjunction with the power system control several command types can be distinguished for the device:

2.18.2.1 Description

Commands to the System

These are all commands that are directly output to the switchgear to change their process state:

- Switching commands for the control of circuit breakers (not synchronized), disconnectors and ground electrode,
- Step Commands, e.g. raising and lowering transformer LTCs
- Setpoint commands with configurable time settings, e.g. to control Petersen coils

Internal / Pseudo Commands

They do not directly operate binary outputs. They serve to initiate internal functions, simulate changes of state or to acknowledge changes of state.

- Manual overriding commands to manually update information on process-dependent objects such as indications and switching states, e.g. if the communication with the process is interrupted. Manually overridden objects are flagged as such in the information status and can be displayed accordingly.
- Tagging commands (for "Setting") for internal object information values, e.g. deleting / presetting switching authority (remote vs. local), parameter set changeovers, data transmission blockage and metered values.
- Acknowledgment and resetting commands for setting and resetting internal buffers or data states.
- Information status command to set/reset the additional "information status" of a process object, such as:
 - Input blocking
 - Output Blocking

2.18.3 Command Sequence

Safety mechanisms in the command sequence ensure that a command can only be released after a thorough check of preset criteria has been successfully concluded. Standard Interlocking checks are provided for each individual control command. Additionally, user-defined interlocking conditions can be programmed separately for each command. The actual execution of the command is also monitored afterwards. The overall command task procedure is described in brief in the following list:

2.18.3.1 Description

Check Sequence

Please observe the following:

- Command Entry, e.g. using the keypad on the local user interface of the device
 - Check Password → Access Rights
 - Check Switching Mode (interlocking activated/deactivated) → Selection of Deactivated interlocking Recognition.
- User configurable interlocking checks
 - Switching Authority
 - Device Position Check (set vs. actual comparison)
 - Interlocking, Zone Controlled (logic using CFC)
 - System Interlocking (centrally, using SCADA system or substation controller)
 - Double Operation (interlocking against parallel switching operation)
 - Protection Blocking (blocking of switching operations by protective functions).
- Fixed Command Checks
 - Internal Process Time (software watch dog which checks the time for processing the control action between initiation of the control and final close of the relay contact)
 - Setting Modification in Process (if setting modification is in process, commands are denied or delayed)
 - Operating equipment enabled as output (if an operating equipment component was configured, but not configured to a binary input, the command is denied)
 - Output Block (if an output block has been programmed for the circuit breaker, and is active at the moment the command is processed, then the command is denied)
 - Board Hardware Error
 - Command in Progress (only one command can be processed at a time for one operating equipment, object-related Double Operation Block)
 - 1-of-n-check (for schemes with multiple assignments, such as relays contact sharing a common terminal a check is made if a command is already active for this set of output relays).

Monitoring the Command Execution

The following is monitored:

- Interruption of a command because of a Cancel Command
- Runtime Monitor (feedback message monitoring time)

2.18.4 System Interlocking

System interlocking is executed by the user-defined logic (CFC).

2.18.4.1 Description

System interlocking checks in a SICAM/SIPROTEC 4 system are usually categorized as follows:

- System interlocking relies on the system data base in the substation or central control system.
- Bay interlocking relies on the object data base (feedbacks) of the bay unit.
- Cross-bay interlocking via GOOSE messages directly between bay units and protection relays (with IEC61850: GOOSE information exchange will be accomplished via EN100-module)

The extent of the interlocking checks is determined by the configuration of the relay. For more information on GOOSE, please refer to the SIPROTEC 4 System Description /1/.

Switching objects that require system interlocking in a central control system are assigned to a specific parameter inside the bay unit (via configuration matrix).

For all commands, operation with interlocking (normal mode) or without interlocking (Interlocking OFF) can be selected:

- for local commands, by reconfiguration via password prompt,
- for automatic commands, via command processing by CFC using non-interlocking detection,
- for local / remote commands, using an additional interlocking disable command, via Profibus.

Interlocked / Non-interlocked Switching

The configurable command checks in the SIPROTEC 4 devices are also called "standard interlocking". These checks can be activated via DIGSI (interlocked switching/tagging) or deactivated (non-interlocked).

Deactivated interlock switching means that the configured interlocking conditions are not checked in the relay.

Interlocked switching means that all configured interlocking conditions are checked within the command processing. If a condition is not fulfilled, the command will be rejected by a message with a minus added to it (e.g. "CO-"), immediately followed by a message.

The following table shows the possible types of commands in a switching device and their corresponding messages. For the device the messages designated with *) are displayed in the event logs, for DIGSI they appear in spontaneous messages.

Type of Command	Control	Cause	Message
Control issued	Switching	CO	CO+/-
Manual tagging (positive / negative)	Manual tagging	MT	MT+/-
Information state command, Input blocking	Input blocking	ST	ST+/- *)
Output Blocking	Output blocking	ST	ST+/- *)
Cancel command	Cancel	CA	CA+/-

The "plus" appearing in the message is a confirmation of the command execution. The command execution was positive as expected. The minus sign means a negative confirmation, the command was rejected. Possible command feedbacks and their causes are dealt with in the SIPROTEC 4 System Description. The following figure shows operational indications relating to command execution and operation response information for successful switching of the circuit breaker.

The check of interlockings can be programmed separately for all switching devices and tags that were set with a tagging command. Other internal control actions, such as manual entry or cancel are not tested, i.e. carried out independent of the interlocking.

EVENT LOG	
19.06.01	11:52:05,625
Q0	CO+ Close
19.06.01	11:52:06,134
Q0	FB+ Close

Figure 2-82 Example of an operational annunciation for switching circuit breaker 52 (Q0)

Standard Interlocking (fixed programming)

The standard interlockings contain the following fixed programmed tests for each switching device, which can be individually enabled or disabled using parameters:

- **Device Status Check (set = actual):** The switching command is rejected, and an error indication is displayed if the circuit breaker is already in the set position. If this check is enabled, then it works whether interlocking, e.g. zone controlled, is activated or deactivated.
- **System Interlocking:** To check system interlocking, a local command is transmitted to the central unit with Switching Authority = LOCAL. A switching device that is subject to system interlocking cannot be switched by DIGSI.
- **Zone Controlled/Bay Interlocking:** Logic links in the device which were created via CFC are interrogated and considered during interlocked switching.
- **Blocked by Protection:** A CLOSE-command is rejected as soon as one of the protective elements in the relay picks up. The OPEN-command, in contrast, can always be executed. Please be aware, activation of thermal overload protection elements or sensitive ground fault detection can create and maintain a fault condition status, and can therefore block CLOSE commands. If the interlocking is removed, consider that, on the other hand, the restart inhibit for motors will not automatically reject a CLOSE command to the motor. Restarting would then have to be interlocked in some other way. One method would be to use a specific interlocking in the CFC logic.
- **Double Operation Block:** Parallel switching operations are interlocked; while one switching operation is being processed a second one can be executed.
- **Switching Authority LOCAL:** A switching command of the local control (command with command source LOCAL) is only allowed if a LOCAL control is allowed at the device (by configuration).
- **Switching Authority DIGSI:** Switching commands that are issued locally or remotely via DIGSI (command with command source DIGSI) are only allowed if remote control is admissible for the device (by configuration). If a DIGSI PC connects to the device, it deposits here its virtual device (VD) number. Only commands with this VD (when Switching Authority = REMOTE) will be accepted by the device. Remote switching commands will be rejected.
- **Switching Authority REMOTE:** A switching control command (command with source of command REMOTE) is only allowed if REMOTE control is admissible at the device (by configuration).

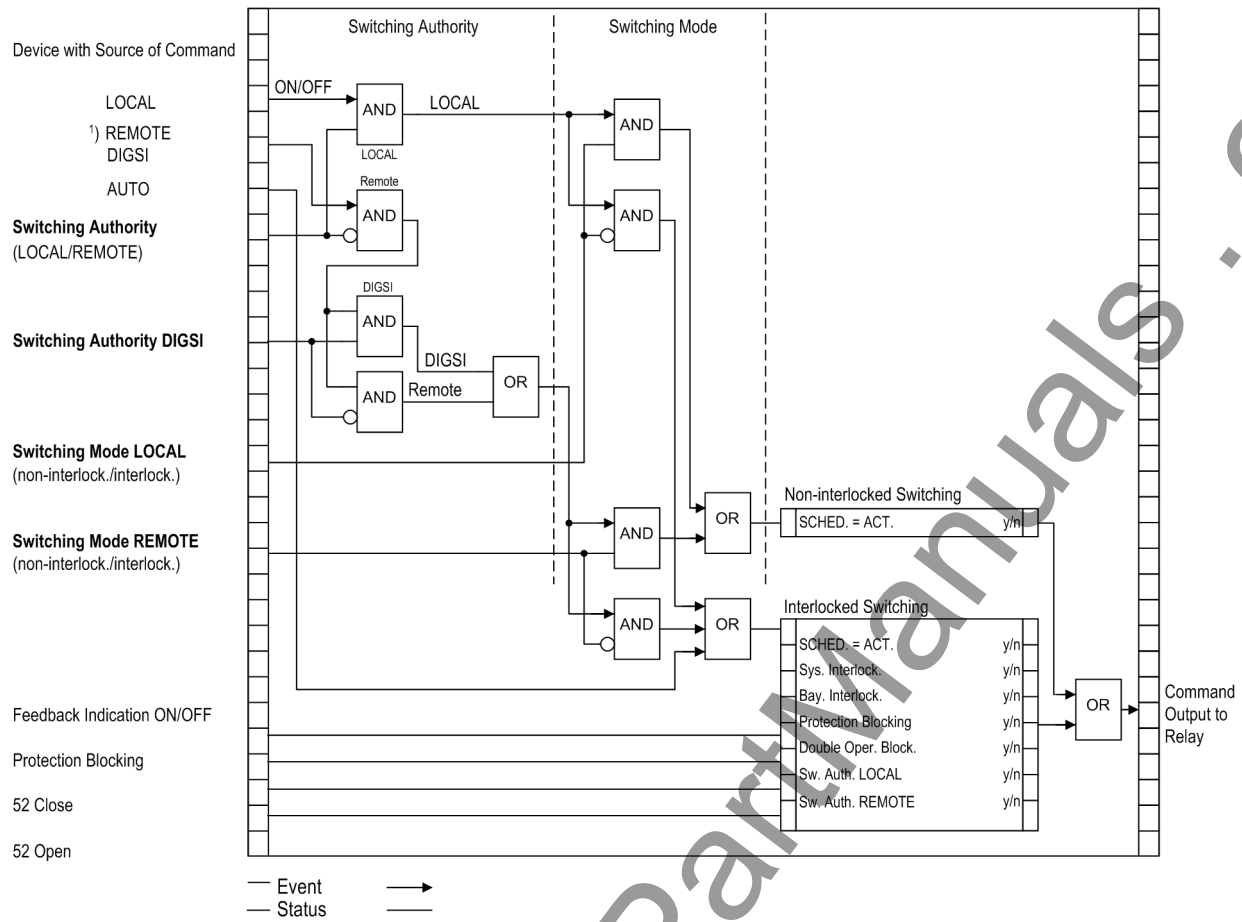

1) Source REMOTE also includes SAS.
 (LOCAL Command using substation controller
 REMOTE Command using remote source such as SCADA through controller.)

Figure 2-83 Standard interlockings

The following figure shows the configuration of the interlocking conditions using DIGSI.

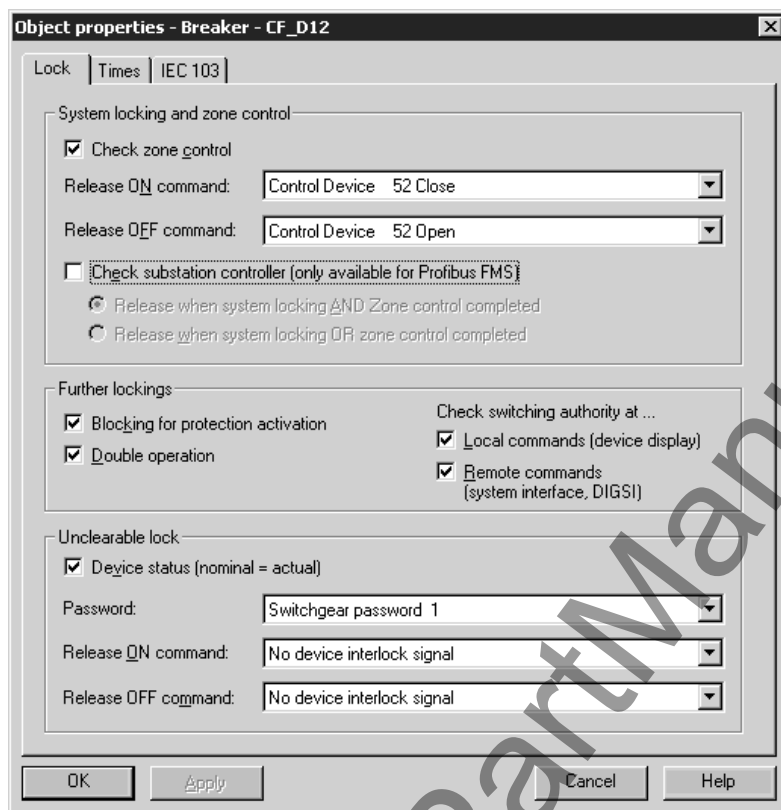

Figure 2-84 DIGSI dialog box for setting the interlocking conditions

The configured interlocking causes appear on the device display. They are marked by letters explained in the following table.

Table 2-18 Command types and corresponding messages

Interlocking Commands	Abbrev.	Message
Switching authority	L	L
System interlocking	S	S
Zone controlled	Z	Z
SET= ACTUAL (switch direction check)	P	P
Protection blockage	B	O

The following figure shows all interlocking conditions (which usually appear in the display of the device) for three switchgear items with the relevant abbreviations explained in the previous table. All parameterized interlocking conditions are indicated.

Interlocking	01/03
Q0 Close/Open S - Z P B	
Q1 Close/Open S - Z P B	
Q8 Close/Open S - Z P B	

Figure 2-85 Example of configured interlocking conditions

Enabling Logic via CFC

For the bay interlocking an enabling logic can be structured using the CFC. Via specific release conditions the information „released“ or „bay interlocked“ are available (e.g. object „52 Close“ and „52 Open“ with the data values ON / OFF).

Switching Authority

The interlocking condition "Switching Authority" serves to determine the switching authorization. It enables the user to select the authorized command source. The following switching authority zones are defined in the following priority sequence:

- LOCAL
- DIGSI
- REMOTE

The object "Switching Authority" serves to interlock or enable LOCAL control, but not REMOTE or DIGSI commands. For the 7SJ61 the switching authority can be changed between "REMOTE" and "LOCAL" in the operator panel after having entered the password or by means of CFC also via binary input and function key.

The "Switching authority DIGSI" is used for interlocking and allows commands to be initiated using DIGSI. Commands are allowed for both remote and a local DIGSI connection. When a (local or remote) DIGSI PC logs on to the device, it enters its Virtual Device Number (VD). The device only accepts commands having that VD (with switching authority = OFF or REMOTE). When the DIGSI PC logs off, the VD is cancelled.

Commands are checked for their source and the device settings, and compared to the information set in the objects "Switching authority" and "Switching authority DIGSI".

Configuration

Switching authority available	y/n (create appropriate object)
Switching authority DIGSI available:	y/n (create appropriate object)
Specific Device (e.g. switching device)	Switching authority LOCAL (check for Local status): y/n
Specific Device (e.g. switching device)	”Switching authority REMOTE (check for LOCAL, REMOTE, or DIGSI commands): y/n

Table 2-19 Interlocking logic

Current Switching Authority Status	Switching Authority DIGSI	Command issued from SC ³⁾ =Local	Command issued from SC=LOCAL or REMOTE	Command issued from SC=DIGSI
LOCAL (ON)	not logged on	not allocated	Interlocked ²⁾ - "interlocked, since control LOCAL"	Interlocked - "DIGSI not logged on"
LOCAL (ON)	logged on	not allocated	Interlocked ²⁾ - "interlocked, since control LOCAL"	Interlocked ²⁾ - "interlocked, since control LOCAL"
REMOTE (OFF)	not logged on	Interlocked ¹⁾ - "interlocked, since control REMOTE"	not allocated	Interlocked - "DIGSI not logged on"
REMOTE (OFF)	logged on	Interlocked ¹⁾ - "interlocked, because of DIGSI control"	Interlocked ²⁾ - "inter-locked, because of DIGSI control"	not allocated

¹⁾ also "allowed" for: "Switching Authority LOCAL (check for Local status): is not marked

²⁾ also "allowed" for: "Switching authority REMOTE (check for LOCAL, REMOTE, or DIGSI commands): is not marked

³⁾ SC = Source of command

SC = Auto:

Commands that are derived internally (command processing in the CFC) are not subject to switching authority and are therefore always "enabled".

Switching Mode

The switching mode determines whether selected interlocking conditions will be activated or deactivated at the time of the switching operation.

The following switching modes (local) are defined:

- Local commands (SC=LOCAL)
 - interlocked (normal), or
 - non-interlocked (de-interlocked) switching.

For the 7SJ61 the switching authority can be changed between "Interlocked" and "Non-interlocked" in the operator panel by password or by means of CFC also via binary input and function key.

The following switching modes (remote) are defined:

- For remote or DIGSI commands (SC = LOCAL, REMOTE, or DIGSI)
 - interlocked, or
 - non-interlocked switching. Here, deactivation of interlocking is accomplished via a separate command.
 - For commands from CFC (SC = Auto), please observe the notes in the CFC manual (component: BOOL to command).

Zone Controlled / Field Interlocking

Zone controlled / Field interlockings (e.g. via CFC) includes the verification that predetermined switchgear position conditions are satisfied to prevent switching errors (e.g. disconnecter vs. ground switch, ground switch only if no voltage applied) as well as verification of the state of other mechanical interlocking in the switchgear bay (e.g. High Voltage compartment doors open against CB closing).

Interlocking conditions can be programmed separately for device control CLOSE and/or OPEN.

The enable information with the data "switching device is interlocked (OFF/NV/FLT) or enabled (ON)" can be set up,

- directly, using a single point or double point indication, key-switch, or internal indication (marking), or
- by means of a control logic via CFC.

When a switching command is initiated, the actual status is scanned cyclically. The assignment is done via "Release object CLOSE/OPEN command".

System Interlocking

Substation Controller (System interlocking) involves switchgear conditions of other bays evaluated by a central control system.

Double Activation Blockage

Parallel switching operations are interlocked. As soon as the command has arrived all command objects subject to the interlocking are checked to know whether a command is being processed. While the command is being executed, interlocking is enabled for other commands.

Blocking by Protection

Protection functions then block switching operations. Protective elements are configured, separately for each switching component, to block specific switching commands sent in CLOSE and TRIP direction.

When enabled, "Block CLOSE commands" blocks CLOSE commands, whereas "Block TRIP commands" blocks TRIP signals. Switching operations in progress will immediately be aborted by the pickup of a protective element.

Device Status Check (set = actual)

For switching commands, a check takes place whether the selected switching device is already in the set/desired position (set/actual comparison). This means, if a circuit breaker is already in the CLOSED position and an attempt is made to issue a closing command, the command will be refused, with the operating message "set condition equals actual condition". If the circuit breaker/switchgear device is in the intermediate position, then this check is not performed.

Bypassing Interlocking

Bypassing configured interlocks at the time of the switching action happens device-internal via interlocking recognition in the command job or globally via so-called switching modes.

- SC=LOCAL
 - The 7SJ61 allows the switching modes "interlocked" or "non-interlocked" to be selected in the operator panel after password entry.
- REMOTE and DIGSI
 - Commands issued by SICAM or DIGSI are unlocked via a global switching mode REMOTE. A separate request must be sent for the unlocking. The unlocking applies only for one switching operation and for command caused by the same source.
 - Job order: command to object "Switching mode REMOTE", ON
 - Job order: switching command to "switching device"
- Derived commands via CFC (automatic command, SC=Auto):
 - Behaviour configured in the CFC block ("BOOL to command").

2.18.5 Command Logging

During the processing of the commands, independent of the further message routing and processing, command and process feedback information are sent to the message processing centre. These messages contain information on the cause. With the corresponding allocation (configuration) these messages are entered in the event list, thus serving as a report.

Prerequisites

A listing of possible operating messages and their meaning as well as the command types needed for tripping and closing of the switchgear or for raising and lowering of transformer taps are described in the SIPROTEC 4 System Description.

2.18.5.1 Description

Acknowledgement of Commands to the Device Front

All messages with the source of command LOCAL are transformed into a corresponding response and shown in the display of the device.

Acknowledgement of Commands to Local / Remote / Digsi

The acknowledgement of messages with source of command Local/ Remote/DIGSI are sent back to the initiating point independent of the routing (configuration on the serial digital interface).

The acknowledgement of commands is therefore not executed by a response indication as it is done with the local command but by ordinary command and feedback information recording.

Monitoring of Feedback Information

The processing of commands monitors the command execution and timing of feedback information for all commands. At the same time the command is sent, the monitoring time is started (monitoring of the command execution). This time controls whether the device achieves the required final result within the monitoring time. The monitoring time is stopped as soon as the feedback information arrives. If no feedback information arrives, a response „Timeout command monitoring time“ appears and the process is terminated.

Commands and information feedback are also recorded in the event list. Normally the execution of a command is terminated as soon as the feedback information (**FB+**) of the relevant switchgear arrives or, in case of commands without process feedback information, the command output resets and a message is output.

The "plus" sign appearing in a feedback information confirms that the command was successful. The command was as expected, in other words positive. The "minus" is a negative confirmation and means that the command was not executed as expected.

Command Output and Switching Relays

The command types needed for tripping and closing of the switchgear or for raising and lowering of transformer taps are described under configuration in /1/.

Mounting and Commissioning

3

This chapter is intended for experienced commissioning staff. He must be familiar with the commissioning of protection and control systems, the management of power systems and the safety rules and regulations. Hardware adjustments to the power system data might be necessary. The primary tests require the protected object (line, transformer, etc.) to carry load.

3.1	Mounting and Connections	258
3.2	Checking Connections	285
3.3	Commissioning	290
3.4	Final Preparation of the Device	303

3.1 Mounting and Connections

General



WARNING!

Warning of improper transport, storage, installation or assembly of the device.

Failure to observe these precautions can result in death, personal injury, or serious material damage. ♦

Trouble-free and safe use of this device depends on proper transport, storage, installation, and assembly of the device according to the warnings in this device manual.

Of particular importance are the general installation and safety regulations for work in a high-voltage environment (for example, ANSI, IEC, EN, DIN, or other national and international regulations). These regulations must be observed.

3.1.1 Configuration Information

Prerequisites

For installation and connections the following requirements and conditions must be met:

The rated device data has been checked as recommended in the SIPROTEC® 4 System Description. Their compliance with the power system data has been verified.

General Diagrams

General diagrams for 7SJ61 are shown in Appendix A.2. Connection examples for current transformer circuits are provided in A.3.

Binary Inputs and Outputs

The configuration options of the binary in- and outputs, i.e. the procedure for the individual adaptation to the plant conditions, are described in the SIPROTEC 4 System Description. The connections to the plant are dependent on this configuration. The presettings of the device are listed in Appendix A.5. Please also check that the labelling strips on the front panel correspond to the configured message functions.

Setting Group Change

If binary inputs are used to switch setting groups, please observe the following:

- Two binary inputs must be dedicated to the purpose of changing setting groups when four groups are to be switched. One binary input must be set for „>Set Group Bit0“, the other input for „>Set Group Bit1“. If either of these input functions is not assigned, then it is considered as not controlled.
- For the control of 2 setting groups one binary input is sufficient, namely „>Set Group Bit0“, since the non-assigned binary input „>Set Group Bit1“ is then regarded as not connected.
- The control signals must be permanently active so that the selected setting group is and remains active.

The following table shows the allocation of the binary inputs to the setting groups A to D and a simplified connection diagram for the two binary inputs is illustrated in the following figure. The figure illustrates an example in which both Set Group Bits 0 and 1 are configured to be controlled (actuated) when the associated binary input is energized (high).

Where:

no = not energized or not connected
yes = energized

Table 3-1 Changing setting groups using binary inputs

Binary Input		Active Group
>Set Group Bit 0	>Set Group Bit 1	
No	No	Group A
Yes	No	Group B
No	Yes	Group C
Yes	Yes	Group D

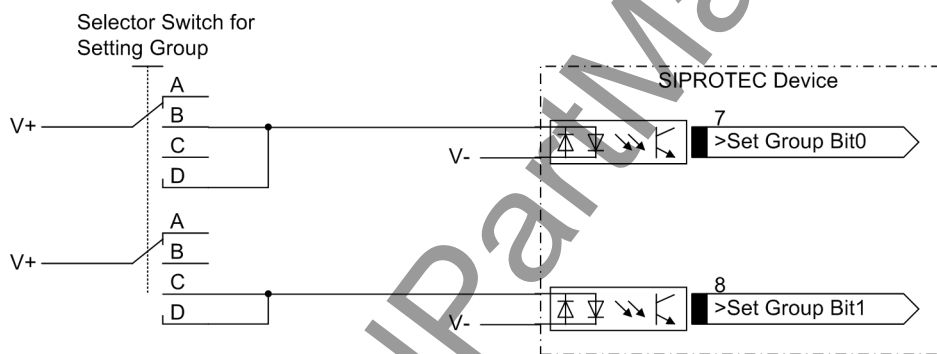

Figure 3-1 Connection diagram (example) for setting group switching using binary inputs

Trip Circuit Supervision

Please note that two binary inputs or one binary input and one bypass resistor R must be connected in series. The pick-up threshold of the binary inputs must therefore stay substantially below half the rated control DC voltage.

If two binary inputs are used for the trip circuit supervision, these binary inputs must be volt-free i.o.w. not be commoned with each other or with another binary input.

If one binary input is used, a bypass resistor R must be used (see following figure). The resistor R is inserted into the circuit of the 52b circuit breaker auxiliary contact to facilitate the detection of a malfunction also when the 52a circuit breaker auxiliary contact is open and the trip contact has dropped out. The value of this resistor must be such that in the circuit breaker open condition (therefore 52a is open and 52b is closed), the circuit breaker trip coil (52TC) is no longer energized and binary input (BI1) is still energized if the command relay contact is open.

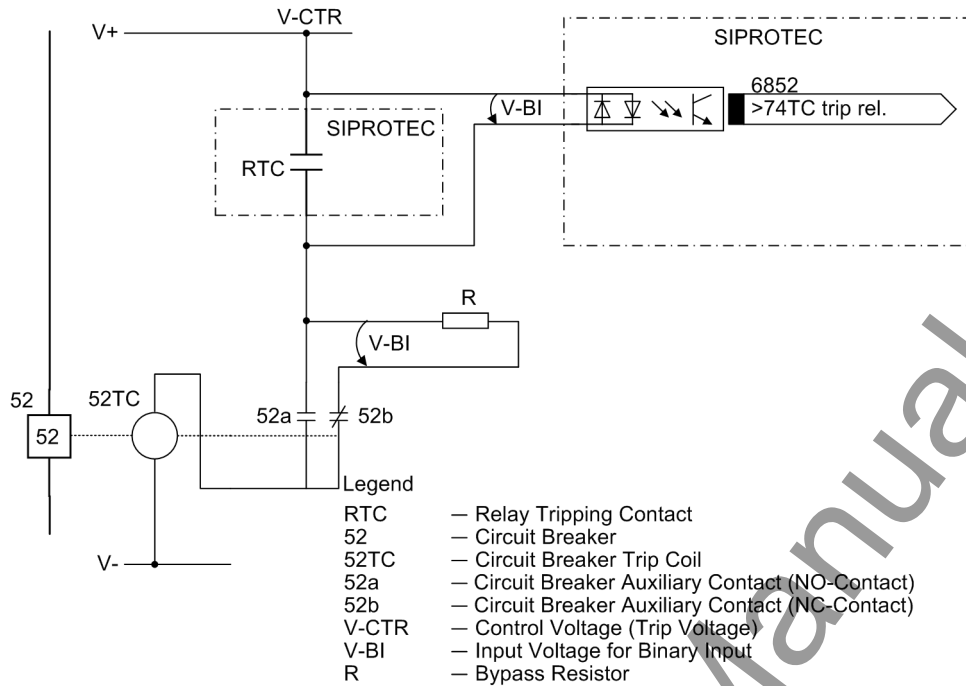

Figure 3-2 Trip circuit supervision with one binary input

This results in an upper limit for the resistance dimension, R_{max} , and a lower limit R_{min} , from which the optimal value of the arithmetic mean R should be selected:

$$R = \frac{R_{max} + R_{min}}{2}$$

In order that the minimum voltage for controlling the binary input is ensured, R_{max} is derived as:

$$R_{max} = \left(\frac{V_{CTR} - V_{BI \min}}{I_{BI \text{ (High)}}} \right) - R_{TC}$$

So the circuit breaker trip coil does not remain energized in the above case, R_{min} is derived as:

$$R_{min} = R_{TC} \cdot \left(\frac{V_{CTR} - V_{TC \text{ (LOW)}}}{V_{TC \text{ (LOW)}}} \right)$$

$I_{BI (HIGH)}$	Constant current with activated BI (= 1.8 mA)
$V_{BI min}$	minimum control voltage for BI (= 19 V for delivery setting for nominal voltage of 24/48/60/125 V; 88 V for delivery setting for nominal voltage of 110/125/220/250 V)
V_{CTR}	Control Voltage for Trip Circuit
R_{CBTC}	DC resistance of circuit breaker trip coil
$V_{CBTC (LOW)}$	Maximum voltage on the circuit breaker trip coil that does not lead to tripping

If the calculation results in $R_{max} < R_{min}$, the calculation must be repeated, with the next lowest switching threshold $V_{BI min}$, and this threshold must be implemented in the relay using plug-in jumpers (see Section „Hardware Modifications“).

For the power consumption of the resistance:

$$P_R = I^2 \cdot R = \left(\frac{V_{CTR}}{R + R_{CBTC}} \right)^2 \cdot R$$

Example:

$I_{BI (HIGH)}$	1.8 mA (SIPROTEC 4 7SJ61)
$V_{BI min}$	19 V for delivery setting for nominal voltage of 24/48/60/125 V (device 7SJ61) 88 V for delivery setting for nominal voltage of 110/125/220/250 V (device 7SJ61)
V_{CTR}	110 V (system / release circuit)
R_{CBTC}	500 Ω (from system / trip circuit)
$V_{CBTC (LOW)}$	2 V (system / release circuit)

$$R_{max} = \left(\frac{110 \text{ V} - 19 \text{ V}}{1.8 \text{ mA}} \right) - 500 \Omega = 50.1 \text{ k}\Omega$$

$$R_{min} = 500 \Omega \cdot \frac{110 \text{ V} - 2 \text{ V}}{2 \text{ V}} = 27 \text{ k}\Omega$$

$$R = \frac{R_{max} + R_{min}}{2} = 38.6 \text{ k}\Omega$$

The closest standard value of 39 kΩ is selected; the power is:

$$P_R = \left(\frac{110 \text{ V}}{39 \text{ k}\Omega + 0.5 \text{ k}\Omega} \right)^2 \cdot 39 \text{ k}\Omega \geq 0.3 \text{ W}$$

3.1.2 Hardware Modifications

3.1.2.1 General

Hardware modifications concerning, for instance, nominal currents, the control voltage for binary inputs or termination of serial interfaces might be necessary. Follow the procedure described in this section, whenever hardware modifications are done.

Auxiliary Voltage

There are different power supply voltage ranges for the auxiliary voltage (refer to the Ordering Information in Appendix A.1). The power supplies of the variants for DC 60/110/125 V and DC 110/125/220 V, AC 115/230 V are largely interchangeable by modifying the position of the jumpers. The assignment of these jumpers to the nominal voltage ranges and their spatial arrangement on the PCB are described in the following Sections. Location and ratings of the miniature fuse and the buffer battery are also shown. When the relays are delivered, these jumpers are set according to the name-plate sticker. Generally, they need not be altered.

Nominal Currents

The input transformers of the devices are set to a nominal current of 1 A or 5 A with jumpers. Jumpers are set according to the name-plate sticker. The assignment of the plug-in jumpers to the nominal current and the spatial arrangement of the jumpers are described in the following sections.

Jumpers X61, X62 and X63 must be set for the same nominal current, i.e. there must be one jumper for each input transformer, and the common jumper X60.

With standard 1/5 A-jumpers jumper X64 for the ground path is set to 1 A or 5 A irrespective of other jumper positions and depending on the ordered variant.

With models equipped with a sensitive ground fault current input (input transformer T4) of setting range 0.001 to 1.500 A there is no jumper X64.

Note



If nominal current ratings are changed by way of exception, then the new ratings must be registered via the parameters 205 **CT SECONDARY**/218 **I_{gnd}-CT SEC** in the Power System Data (see Section 2.1.3.2).

Control Voltage for Binary Inputs

When the device is delivered from the factory, the binary inputs are set to operate with a voltage that corresponds to the rated DC voltage of the power supply. In general, to optimize the operation of the inputs, the pickup voltage of the inputs should be set to most closely match the actual control voltage being used.

A jumper position is changed to adjust the pickup voltage of a binary input. The assignment of the plug-in jumpers to the contact type and the spatial arrangement of the jumpers are described in the following sections.



Note

If binary inputs are used for trip circuit monitoring, please note that two binary inputs (or one binary input and one replacement resistor) must be connected in series. The switching threshold must lie significantly below half the nominal voltage.

Contact Mode for Binary Outputs

Input/output boards can have relays that are equipped with changeover contacts. Therefore it is necessary to rearrange a jumper. To which relays of which boards this applies is described in the following sections.

Replacing Interfaces

Only serial interfaces of devices for panel and cubicle flush mounting are replaceable. Which interfaces can be exchanged, and how this is done, is described in the following section under the margin heading "Exchanging Interface Modules".

Termination of Bus-capable Interfaces

If the device is equipped with a serial RS485 interface or Profibus, they must be terminated with resistors at the last device on the bus to ensure reliable data transmission. For this purpose, terminating resistors are provided on the PCB of the CPU processor module and on the RS485 or PROFIBUS interface module which can be connected via jumpers. Here, only one option can be used. The physical arrangement of the jumpers on the PCB of the corresponding processor board CPU is described in the following sections under margin heading „Processor Board CPU“. The arrangement of the jumpers on the interface modules is described under margin heading „RS485/RS232“ and „Profibus Interface (FMS/DP) DNP3.0/Modbus“. Both jumpers must always be plugged identically.

The terminating resistors are disabled on delivery.

Spare Parts

Spare parts can be the buffer battery that provides for storage of the data in the battery-buffered RAM when the supply voltage fails, and the miniature fuse of the internal power supply. Their physical arrangement is shown in the figures of the processor boards. The ratings of the fuse are printed on the board next to the fuse. When exchanging the fuse, please observe the hints given in the SIPROTEC 4 System Description under "Maintenance" and "Corrective Action / Repairs".

3.1.2.2 Disassembly

Work on the Printed Circuit Boards

**Note**

Before carrying out the following steps, make sure that the device is not operative.

**Caution!****Caution when changing jumper settings that affect nominal values of the device**

As a consequence, the ordering number (MLFB) and the ratings that are stated on the nameplate do no longer match the actual device properties.

If such changes are necessary, the changes should be clearly and fully noted on the device. Self adhesive stickers are available that can be used as replacement nameplates.

To perform work on the printed circuit boards, such as checking or moving switching elements or exchanging modules, proceed as follows:

- Prepare working area: Provide a grounded mat for protecting components subject to damage from electrostatic discharges (ESD). The following equipment is required:
 - screwdriver with a 5 to 6 mm wide tip,
 - 1 Phillips screwdriver,
 - 5 mm socket or nut driver.
 - Unfasten the screw-posts of the D-subminiature connector on the back panel at location "A". This activity is not necessary if the device is designed for surface mounting.
 - If, besides the interface at location "A", there are further interfaces at location "B" and/or "C", also remove the screws located diagonally to the interfaces. This is not necessary if the device is designed for surface mounting.
 - Remove the four or six caps on the front cover and loosen the screws that become accessible.
 - Carefully take off the front cover.
-

Work on the Plug Connectors

**Caution!****Mind electrostatic discharges**

Non-observance can result in minor personal injury or material damage.

When working on plug connectors, electrostatic discharges must be avoided by previously touching a grounded metal part.

Do not plug or withdraw interface connections under power!

Here, the following must be observed:

- Disconnect the ribbon cable between the front cover and the A-CPU board (No. 1 in the following figure) on the front cover side. Press the top latch of the plug connector up and the bottom latch down so that the plug connector of the ribbon cable is pressed out.
- Disconnect the ribbon cables between the A-CPU unit (No. 1) and the input/output printed circuit board A-I/O (No. 2).
- Remove the boards and set them on the grounded mat to protect them from ESD damage. In the case of the device variant for panel surface mounting, please be aware of the fact that a certain amount of force is required to remove the A-CPU board due to the existing plug connector.
- Check the jumpers according to Figures 3-4 to and the following information, and as the case may be change or remove them.

Board Arrangement

The arrangement of the printed circuit boards (PCBs) can be seen in the following figure.

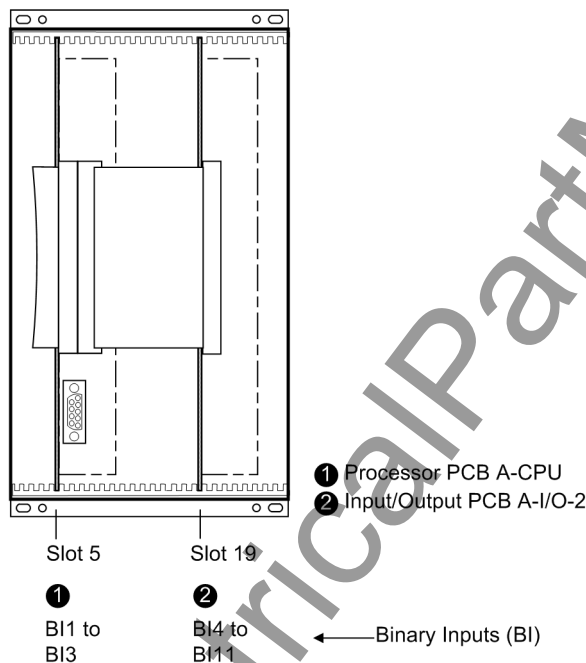

Figure 3-3 Front view of 7SJ61 after removal of the front cover (simplified and scaled down)

3.1.2.3 Switch elements on the PCBs

Three different releases of the A-CPU board are available. They are shown in the following figures. The location of the miniature fuse (F1) and of the buffer battery (G1) are also shown in the following figures.

Processor Board A-CPU for 7SJ61.../DD

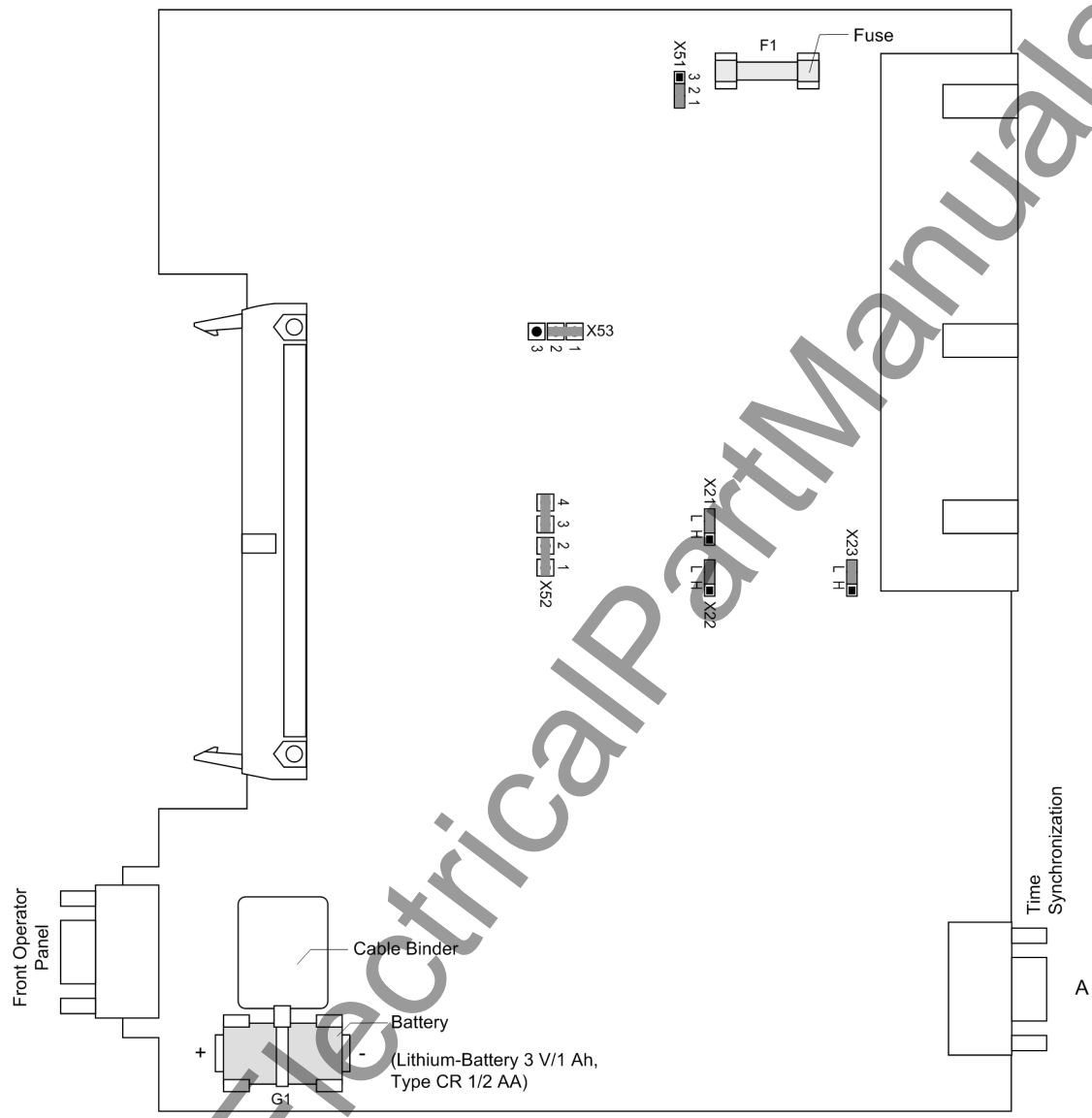

Figure 3-4 Processor printed circuit board A-CPU for devices up to release .../DD with jumpers settings required for the board configuration

The provided nominal voltage of the integrated power supply is checked according to Table 3-2, the selected control voltages of the binary inputs BI1 to BI7 according to Table 3-3.

Power Supply

Table 3-2 Jumper settings for the nominal voltage of the integrated **power supply** on the processor board A-CPU to 7SJ61.../DD

Jumper	Rated Voltage			
	60 to 125 VDC	110 to 250 VDC 115 VAC	24/48 VDC	230 VAC
X51	1-2	2-3	Jumpers X51 to X53 are not used	
X52	1-2 and 3-4	2-3		
X53	1-2	2-3		
	interchangeable		cannot be changed	

Pickup Voltages of BI1 to BI3

Table 3-3 Jumper settings for the **pickup voltages** of the binary inputs BI1 to BI3 on the processor board A-CPU to 7SJ61.../DD

Binary Inputs	Jumper	19 VDC Pickup ¹⁾	88 VDC Pickup ²⁾
BI1	X21	L	H
BI2	X22	L	H
BI3	X23	L	H

¹⁾ Factory settings for devices with rated supply voltage DC 24 to 125 V

²⁾ Factory settings for devices with power supply voltages of 110 VDC to 220 VDC and 115/230 VAC

Processor Board A-CPU for 7SJ61.../EE

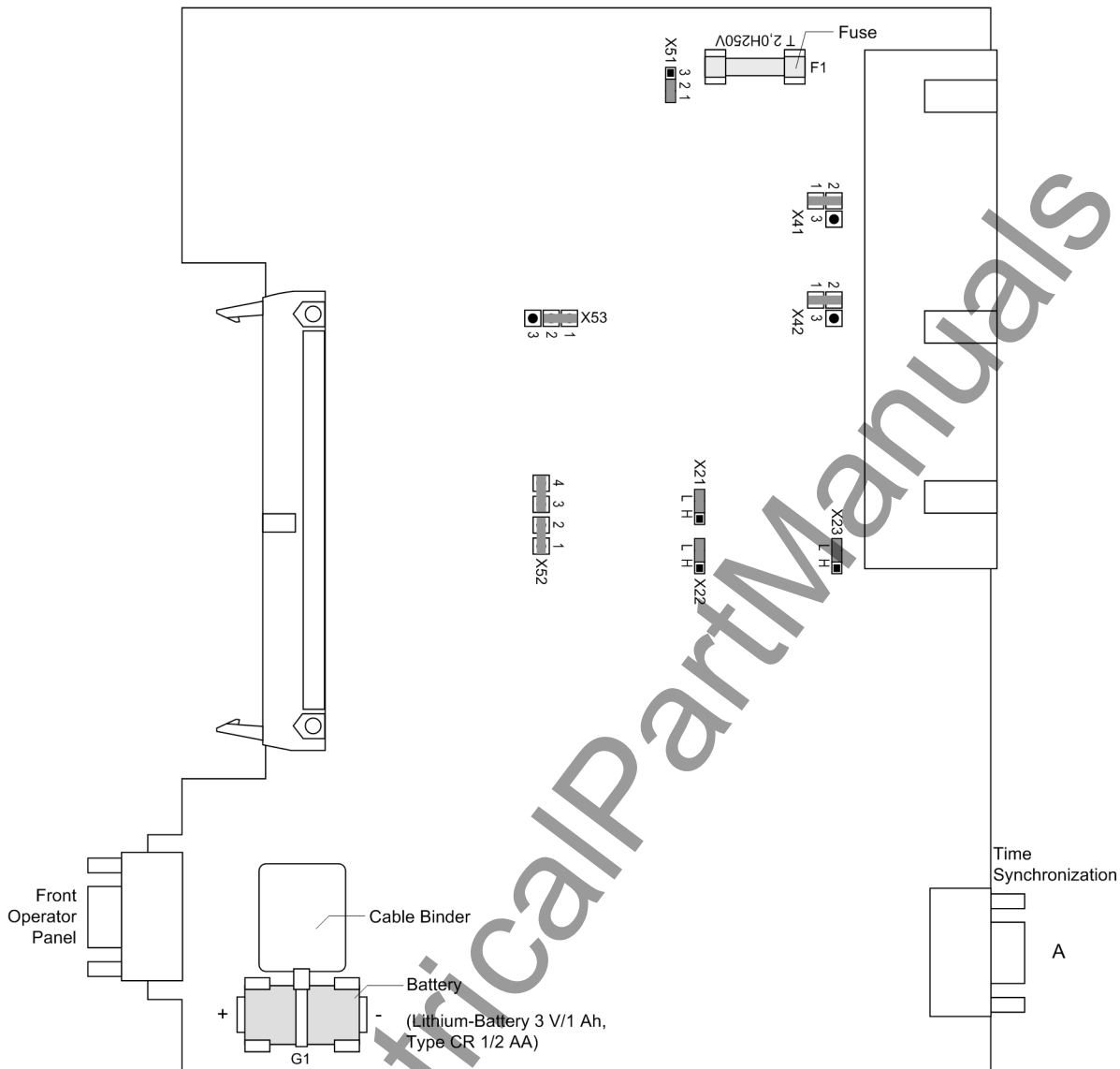

Figure 3-5 Processor printed circuit board A-CPU for devices releases .. /EE and higher with jumpers settings required for the module configuration (up to firmware V4.6)

The preset nominal voltage of the integrated power supply is checked according to Table 3-7, the pickup voltages of the binary inputs BI1 to BI3 are checked according to Table 3-8, and the contact mode of the binary outputs (BO1 and BO2) is checked according to Table 3-6.

Power Supply

Table 3-4 Jumper settings for the nominal voltage of the integrated **power supply** on the processor board A-CPU to 7SJ61.../EE

Jumper	Nominal Voltage		
	24/48 VDC	60 to 125 VDC	110 to 250 VDC 115 to 230 VAC
X51	Not used	1-2	2-3
X52	Not used	1-2 and 3-4	2-3
X53	Not used	1-2	2-3
	cannot be changed	interchangeable	

Pickup voltages of BI1 to BI3

Table 3-5 Jumper settings for the **pickup voltages** of the binary inputs BI1 to BI3 on the processor printed circuit board A-CPU for 7SJ61.../EE

Binary Inputs	Jumper	19 VDC Pickup ¹⁾	88 VDC Pickup ²⁾
BI1	X21	L	H
BI2	X22	L	H
BI3	X23	L	H

¹⁾ Factory settings for devices with rated supply voltage DC 24 to 125 V

²⁾ Factory settings for devices with power supply voltages of 110 VDC to 220 VDC and 115/230 VAC

Contact Mode for Binary Outputs BO1 and BO2

Table 3-6 Jumper settings for the **contact mode** of the relays BO1 and BO2 on the processor printed circuit board A-CPU for 7SJ61.../EE

for	Jumper	Open in quiescent state (NO)	Closed in quiescent state (NC)	Presetting
BO1	X41	1-2	2-3	1-2
BO2	X42	1-2	2-3	1-2

Processor Board A-CPU for 7SJ61.../FF

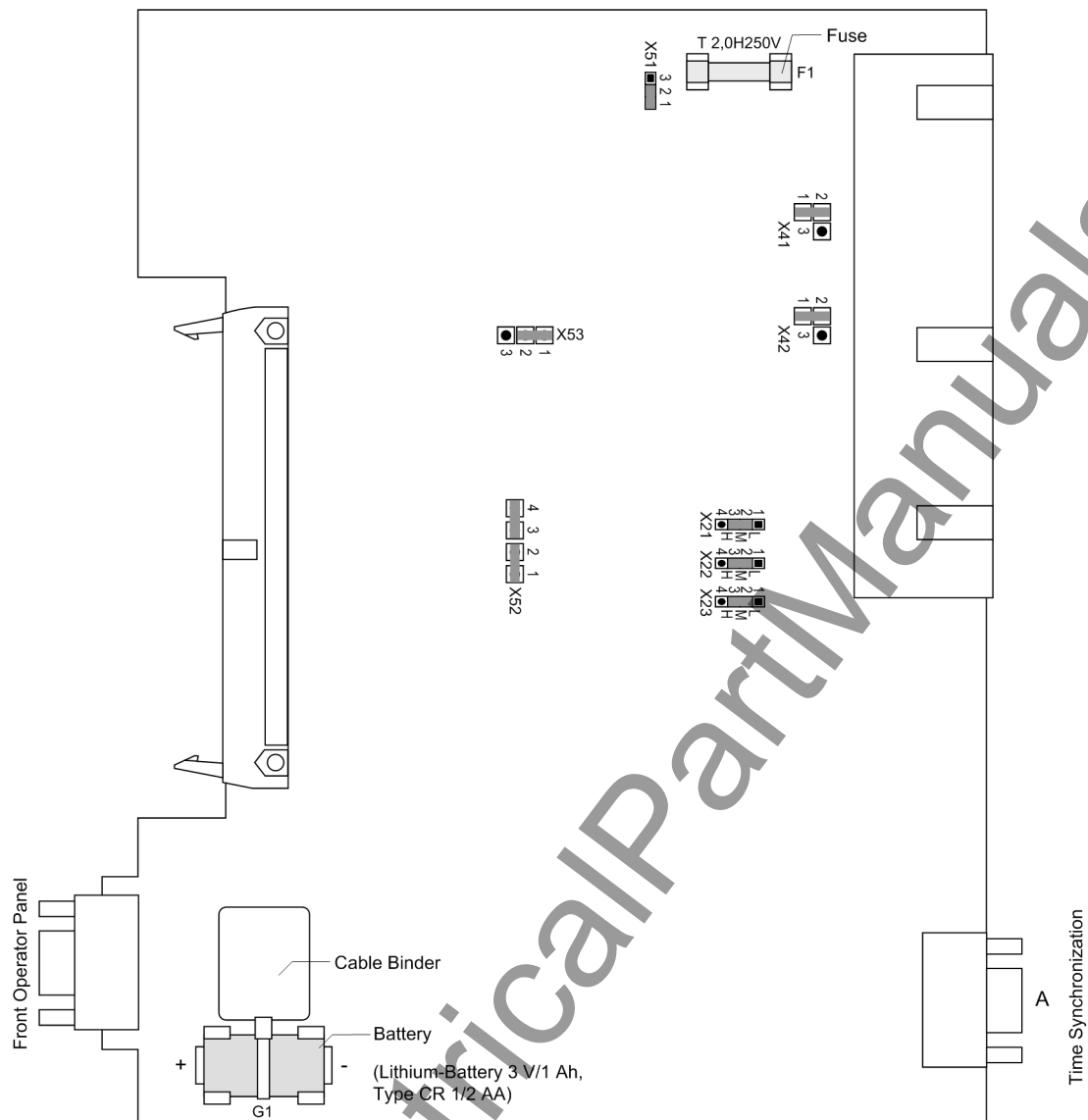

Figure 3-6 Processor printed circuit board A-CPU for devices releases .../FF and higher with jumpers settings required for the module configuration (as from firmware V4.7)

Power Supply

Table 3-7 Jumper settings for the nominal voltage of the integrated **power supply** on the processor board A–CPU as from 7SJ61.../FF

Jumper	Rated Voltage		
	24/48 VDC	60 to 125 VDC	110 to 250 VDC, 115 to 230 VAC
X51	not used	1-2	2-3
X52	not used	1-2 and 3-4	2-3
X53	not used	1-2	2-3
	not changeable	interchangeable	

Pickup voltages of BI1 to BI3

Table 3-8 Jumper settings for the **pickup voltages** of the binary inputs BI1 to BI3 on the processor board A–CPU as from 7SJ61.../FF

Binary Inputs	Jumper	19 VDC Pickup ¹⁾	88 VDC Pickup ²⁾	176 V threshold
BI1	X21	L	M	H
BI2	X22	L	M	H
BI3	X23	L	M	H

¹⁾ Factory settings for devices with rated supply voltage DC 24 to 125 V

²⁾ Factory settings for devices with power supply voltages of 110 VDC to 220 VDC and 115/230 VAC

Contact Mode for Binary Outputs BO1 and BO2

Table 3-9 Jumper settings for the **contact mode** of relays BO1 and BO2 on the processor board A–CPU as from 7SJ61.../FF

for	Jumper	Open in quiescent state (NO)	Closed in quiescent state (NC)	Presetting
BO1	X41	1-2	2-3	1-2
BO2	X42	1-2	2-3	1-2

Input/Output Board A-I/O-2 for 7SJ61.../EE

The layout of the printed circuit board for the input/output board A-I/O-2 is illustrated in the following Figure. The set nominal currents of the current input transformers and the selected operating voltage of binary inputs BI4 to BI11 are checked.

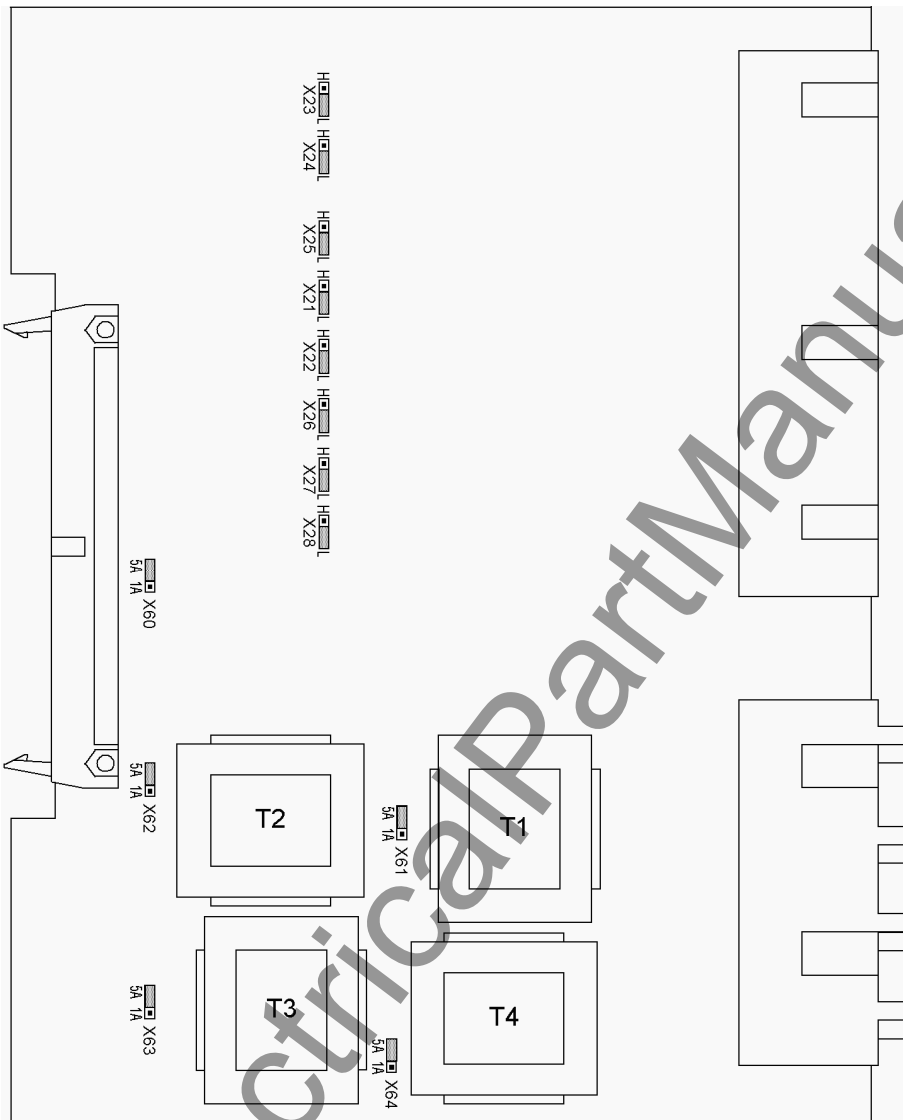

Figure 3-7 Input/output module A-I/O-2 for devices (releases .../EE and higher) with representation of the jumper settings required for the board configuration

The jumpers X60 to X63 must all be set to the same rated current, i.e. one jumper (X61 to X63) for each input transformer and in addition the common jumper X60. The jumper X64 determines the rated current for the input I_N and may thus have a setting that deviates from that of the phase currents. In models with sensitive ground fault current input there is no jumper X64.

Jumpers X21 to X28 do not exist in device versions 7SJ610*.

Pickup voltage of BI4 to BI11

Table 3-10 Jumper settings for **pickup voltages** of binary inputs BI4 to BI11 on the input/output board A-I/O-2 up to 7SJ61.../EE

Binary Inputs	Jumper	19 VDC Pickup ¹⁾	88 VDC Pickup ²⁾
BI4	X21	L	H
BI5	X22	L	H
BI6	X23	L	H
BI7	X24	L	H
BI8	X25	L	H
BI9	X26	L	H
BI10	X27	L	H
BI11	X28	L	H

¹⁾ Factory settings for devices with rated supply voltage DC 24 to 125 V

²⁾ Factory settings for devices with power supply voltages of 110 VDC to 220 VDC and 115/230 VAC

Input/Output Board A-I/O-2 for 7SJ61.../FF

The layout of the printed circuit board for the input/output board A-I/O-2 is illustrated in the following figure. The set nominal currents of the current input transformers and the selected operating voltage of binary inputs BI4 to BI11 are checked.

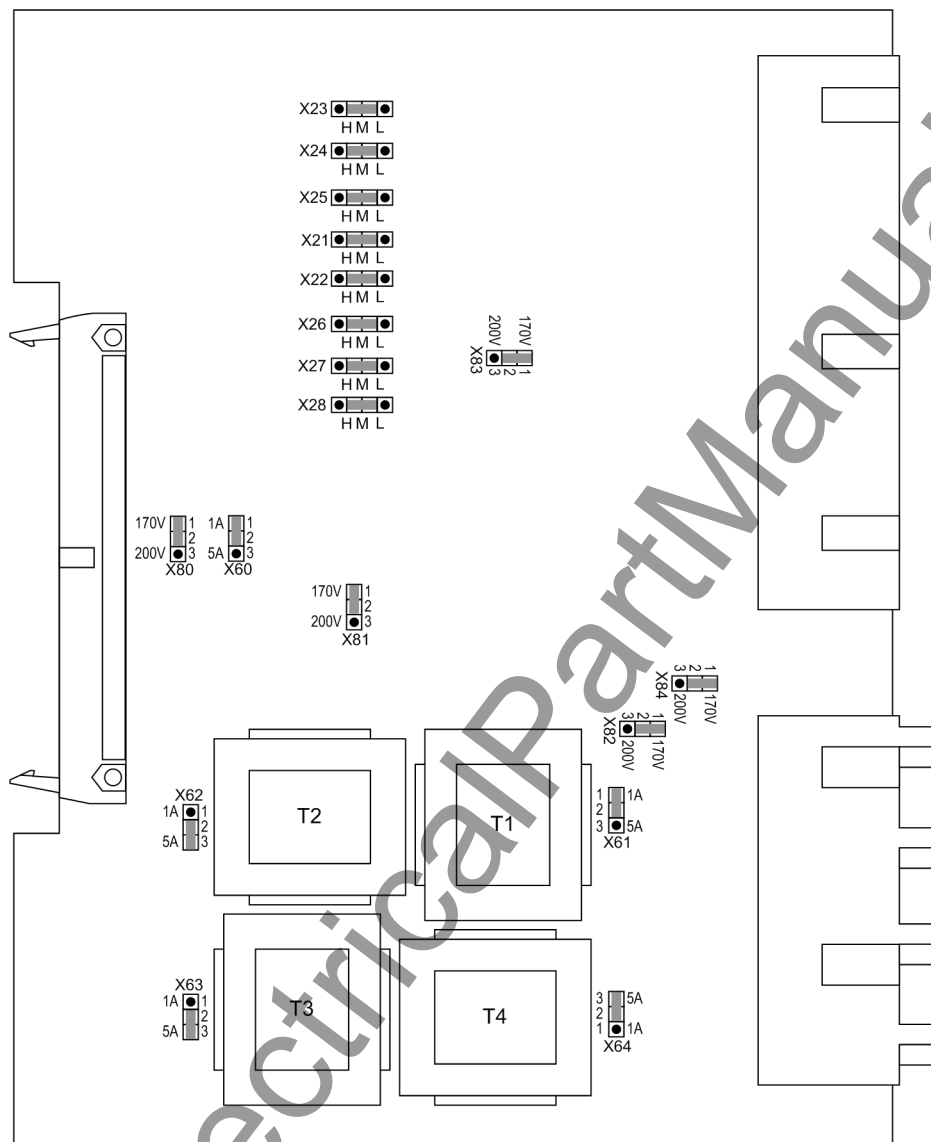

Figure 3-8 Input/output module A-I/O-2 for devices (releases .../FF and higher) with representation of the jumper settings required for the board configuration

The jumpers X60 to X63 must all be set to the same rated current, i.e. one jumper (X61 to X63) for each input transformer and in addition the common jumper X60. The jumper X64 determines the rated current for the input I_N and may thus have a setting that deviates from that of the phase currents. In models with sensitive ground fault current input there is no jumper X64.

Jumpers X80 to X85 are irrelevant for 7SJ61 devices.

Jumpers X21 to X28 do not exist in device versions 7SJ610*.-.

Pickup Voltage of BI4 to BI11

Table 3-11 Jumper settings for **pickup voltages** of binary inputs BI4 to BI11 on the input/output board A-I/O-2 as from 7SJ61.../FF

Binary Inputs	Jumper	19 VDC Pickup ¹⁾	88 VDC Pickup ²⁾	176 V threshold
BI4	X21	L	M	H
BI5	X22	L	M	H
BI6	X23	L	M	H
BI7	X24	L	M	H
BI8	X25	L	M	H
BI9	X26	L	M	H
BI10	X27	L	M	H
BI11	X28	L	M	H

¹⁾ Factory settings for devices with rated supply voltage DC 24 to 125 V

²⁾ Factory settings for devices with power supply voltages of 110 VDC to 220 VDC and 115/230 VAC

3.1.2.4 Interface Modules

Exchanging Interface Modules

The following Figure shows the processor printed circuit board CPU and arrangement of the modules.

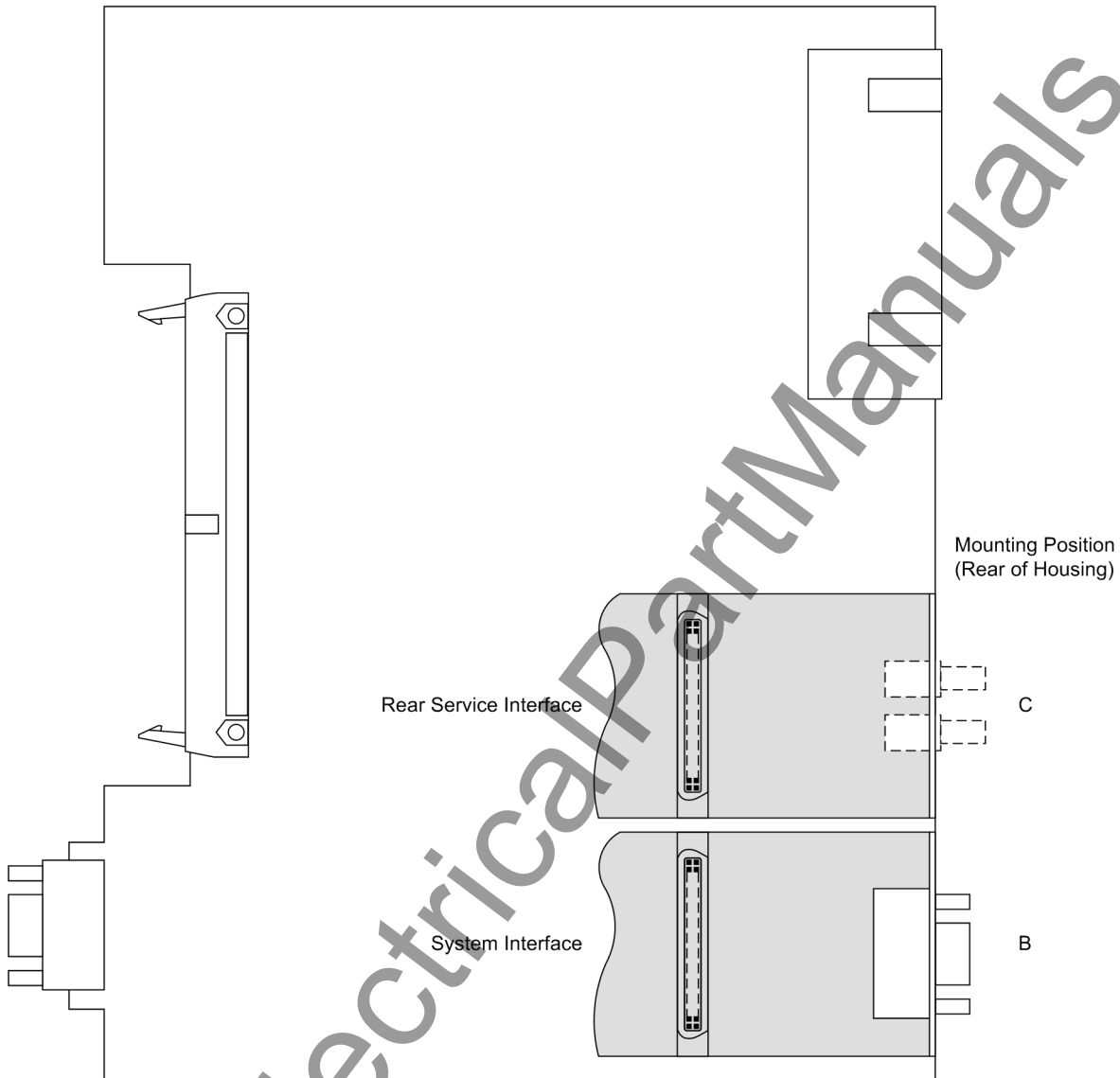

Figure 3-9 Processor printed circuit board CPU with interface modules

The interface modules are located on the processor printed circuit boards CPU (No.1 in Figure 3-3).

Please note the following:

- The interface modules can only be exchanged in devices designed for panel and cubicle mounting. Devices in surface-mounted housings with two-tier terminals have to be retrofitted at our factory.
- Use only interface modules that can be ordered in our facilities via the order key, see also Appendix A.1.
- You may have to ensure the termination of the ports featuring bus capability according to the margin heading "Termination".

Table 3-12 Exchangeable interface modules

Interface	Mounting Location / Port	Exchange Module
System Interface		IEC 60870-5-103 RS232
		IEC 60870-5-103 RS485
		IEC 60870-5-103 redundant RS485
		FO 820 nm
		Provide FM R
		Profibus FMS double ring
		Profibus FMS single ring
		Profibus DP RS485
		Profibus DP double ring
		Modbus RS485
		Modbus 820 nm
		DNP 3.0 RS 485
		DNP 3.0 820 nm
		IEC 61850 Ethernet electrical
IEC 61850 Ethernet optical		
DIGSI /Modem Interface/RTD-box	C	RS232
		RS485
		FO 820 nm

The order numbers of the exchange modules can be found in the Appendix in Section A.1, Accessories.

RS232 interface

Interface RS232 can be modified into interface RS485 and vice versa (see Figures 3-10 and 3-11).

Figure 3-9 shows the printed circuit board of A-CPU and the interface modules.

The following figure shows the location of the jumpers of interface RS232 on the interface module.

Devices in surface mounting housing with fiber optics connection have their fiber optics module housed in the console housing. The fiber optics module is controlled via a RS232 interface module at the associated CPU interface slot. For this application type the jumpers X12 and X13 on the RS232 module are plugged in position 2-3.

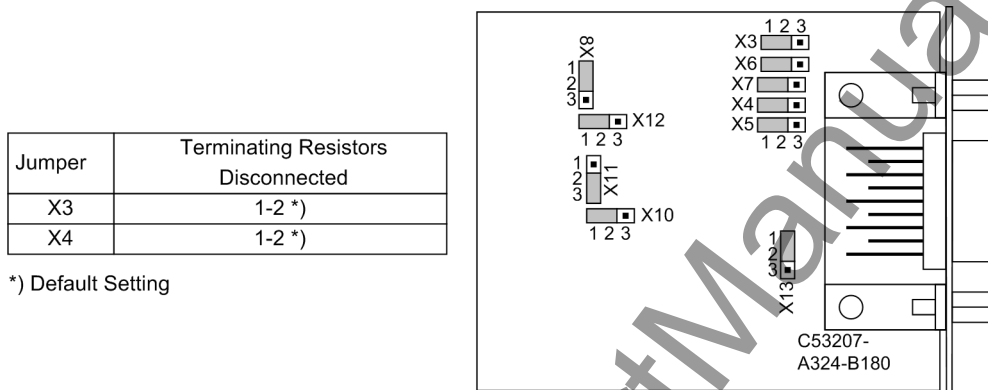

Figure 3-10 Location of the jumpers for configuration of RS232

Terminating resistors are not required. They are permanently disconnected.

Jumper X11 enables the **flow control (CTS)** feature which is important for modem communication.

Table 3-13 Jumper setting for **CTS (Clear to Send)** on the interface module

Jumper	/CTS from interface RS232	/CTS controlled by /RTS
X11	1-2	2-3 ¹⁾

1) Default setting

Jumper setting 2-3: The modem connection is usually established with star coupler or fiber optic converter. Therefore the modem control signals according to RS232 Standard DIN 66020 are not available. The modem signals are not required since the connection to the SIPROTEC 4 devices is always operated in the half-duplex mode. Please use the connection cable with order number 7XV5100-4.

Jumper setting 2-3 is equally required when using the RTD boxes in half-duplex operation.

Jumper setting 1-2: This setting makes the modem signals available, i.e. for a direct RS232 connection between the SIPROTEC 4 device and the modem this setting can be selected optionally. We recommend to use a standard RS232 modem connection cable (converter 9-pin to 25-pin).

Note

For a direct connection to DIGSI with interface RS232, jumper X11 must be plugged in position 2-3.

RS485 Interface

The following figure shows the location of the jumpers of interface RS485 on the interface module.

Interface RS485 can be modified to interface RS232 and vice versa, according to Figure 3-10.

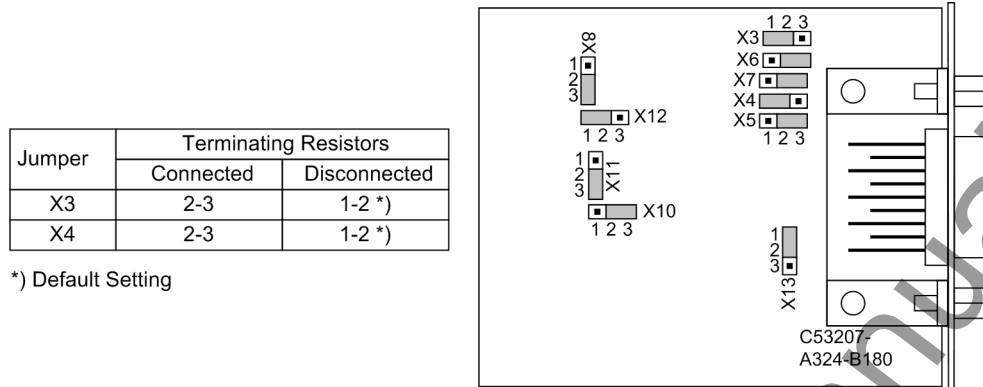

Figure 3-11 Position of terminating resistors and the plug-in jumpers for configuration of the RS485 interface

Profibus (FMS/DP), DNP 3.0/Modbus

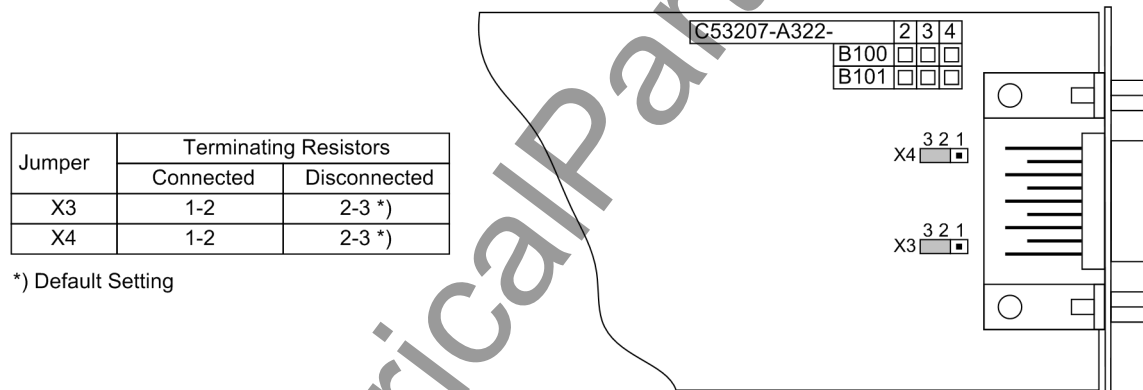

Figure 3-12 Position of the plug-in jumpers for the configuration of the terminating resistors at the Profibus (FMS and DP), DNP 3.0 and Modbus interfaces.

IEC 61850 Ethernet (EN100)

The interface module does not feature any jumpers. Its use does not require any hardware adaptations.

IEC 60870-5-103 redundant

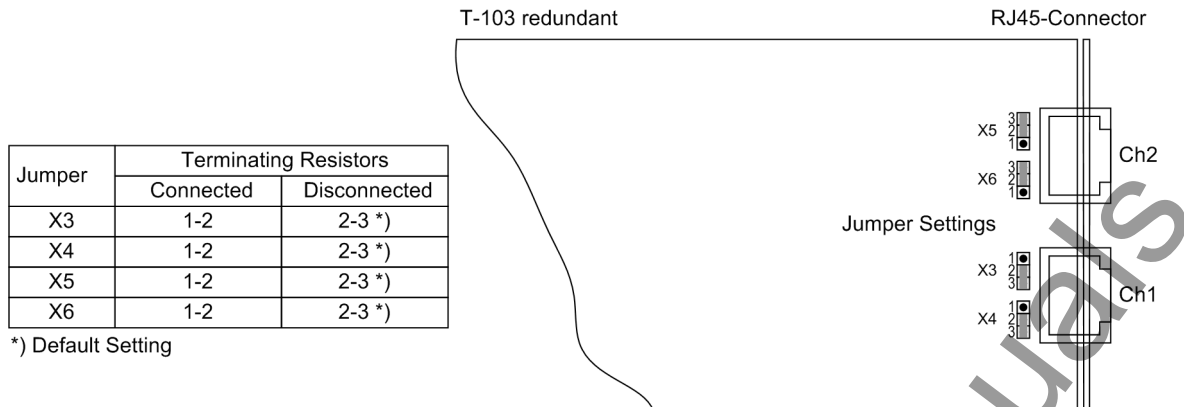

Figure 3-13 Location of the jumpers for configuration of the terminating resistors

Termination

Busbar capable interfaces always require a termination at the last device to the bus, i.e. terminating resistors must be connected. On the 7SJ61 device, this applies to variants with RS485 or PROFIBUS interfaces.

The terminating resistors are located on the RS485 or Profibus interface module mounted on the processor input/output board CPU (serial no. 1 in Figure 3-3).

With default setting the jumpers are set such that the terminating resistors are disconnected. Both jumpers of a board must always be plugged in the same way.

The terminating resistors can also be connected externally (e.g. to the connection module), see Figure 3-14. In this case, the terminating resistors located on the RS485 or Profibus interface module or directly on the PCB of the processor module CPU must be switched OFF.

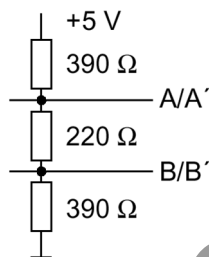

Figure 3-14 Termination of the RS485 interface (external)

3.1.2.5 Reassembly

The device is assembled in the following steps:

- Carefully insert the boards into the case. The mounting locations are shown in figure 3-3. For the model of the device designed for surface mounting, use the metal lever to insert the processor circuit board A-CPU. The installation is easier with the lever.
- First, plug the plug connector of the ribbon cable onto the input/output board I/O and then onto the A-CPU processor board. Do not bend any connector pins! Do not use force!
- Insert the plug connector of the ribbon cable between the processor board A-CPU and the front cover in the socket on the front cover.
- Press the latches of the plug connectors together.
- Replace the front cover and secure to the housing with the screws.
- Mount the covers again.
- Re-fasten the interfaces on the rear of the device housing. This activity is not necessary if the device is designed for surface mounting.

3.1.3 Installation

3.1.3.1 Panel Flush Mounting

For installation proceed as follows:

- Remove the 4 covers on the corners of the front plate. Thus, 4 elongated holes are revealed in the mounting bracket and can be accessed.
- Insert the device into the panel cut-out and fasten it with four screws. For dimensions refer to Section 4.22.
- Replace the 4 covers.
- Connect the ground on the rear plate of the device to the protective ground of the panel. Using at least one M4 screw. The cross-sectional area of the ground wire must be equal to the cross-sectional area of any other control conductor connected to the device. The cross-section of the ground wire must be at least 2.5 mm².
- Connections are realized via the plug terminals or screw terminals on the rear side of the device according to the circuit diagram. When using forked lugs for direct connections or screw terminal, the screws, before having inserted the lugs and wires, must be tightened in such a way that the screw heads are even with the terminal block. A ring lug must be centered in the connection chamber, in such a way that the screw thread fits in the hole of the lug. The SIPROTEC® System Description provides information regarding wire size, lugs, bending radii, etc. which must be observed.

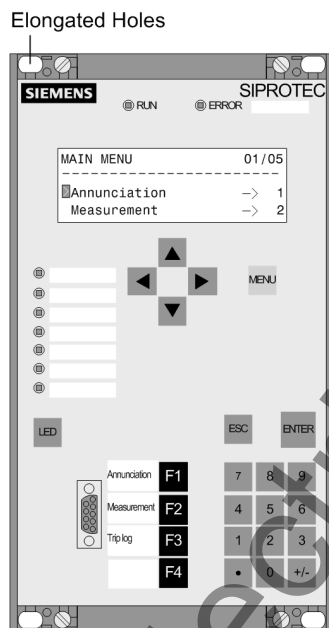

Figure 3-15 Panel flush mounting of a 7SJ61

3.1.3.2 Rack Mounting and Cubicle Mounting

To install the device in a frame or cubicle, two mounting brackets are required. The ordering codes are stated in Appendix, Section A.1

- Screw on loosely the two mounting brackets in the rack or cabinet, each with four screws.
- Remove the 4 covers on the corners of the front plate. Thus, 4 elongated holes are revealed in the mounting bracket and can be accessed.
- Tighten the unit with 4 screws at the angle brackets.
- Replace the 4 covers.
- Tighten fast the eight screws of the angle brackets in the rack or cabinet.
- Connect the ground on the rear plate of the device to the protective ground of the rack. Use at least one M4 screw for the device ground. The cross section of the wire must be equal to the maximum connection cross section area but be at least 2.5 mm².
- Connections are realized via the plug terminals or screw terminals on the rear side of the device according to the circuit diagram. When using forked lugs for direct connections or screw terminal, the screws, before having inserted the lugs and wires, must be tightened in such a way that the screw heads are even with the terminal block. A ring lug must be centered in the connection chamber, in such a way that the screw thread fits in the hole of the lug. The SIPROTEC® 4 System Description has pertinent information regarding wire size, lugs, bending radii, etc.

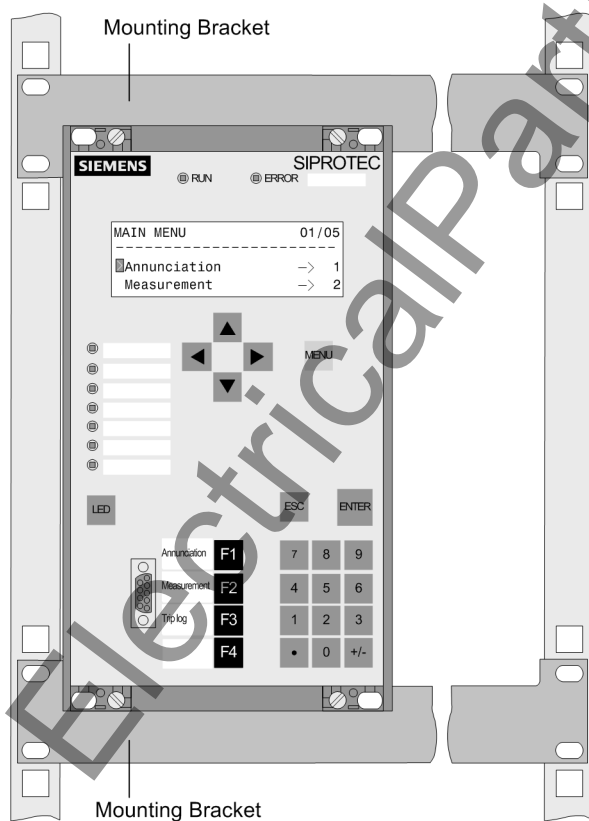

Figure 3-16 Installing a device in a rack or cubicle (housing size 1/3)

3.1.3.3 Panel Flush Mounting

For installation proceed as follows:

- Secure the device to the panel with four screws. For dimensions see the Technical Data, Section 4.22.
- Connect the robust low-ohmic protective ground or station ground to the grounding terminal on the rear plate of the device. The cross-sectional area of the cable used must correspond to the maximum connected cross-section, but must be at least 2.5 mm².
- Alternatively, fasten the said ground to the grounding surface on the side with at least one M4 screw.
- Connections according to the circuit diagram via screw terminals, connections for optical fiber cable and electrical communication modules via the housings. The SIPROTEC 4 System Description provides information regarding maximum wire size, torque, bending radius and cable relief and must be observed.

3.2 Checking Connections

3.2.1 Checking Data Connections of Serial Interfaces

Pin Assignments

The following tables illustrate the pin assignments of the various serial device interfaces, of the time synchronization interface and of the Ethernet interface. The position of the connections can be seen in the following figure.

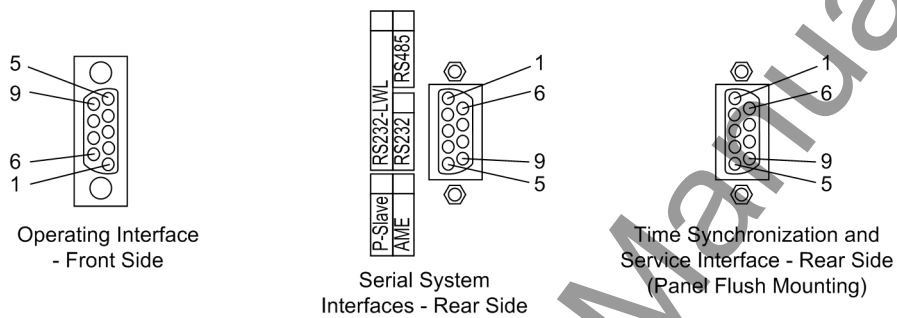

Figure 3-17 9-pin D-subminiature female connectors

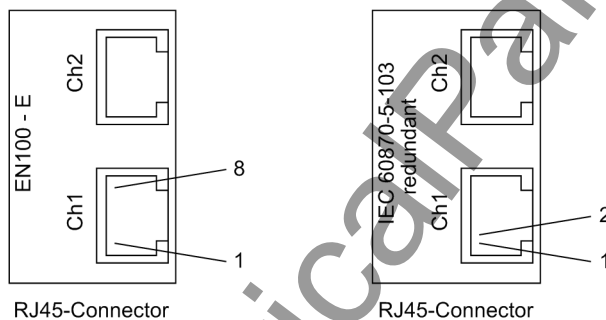

Figure 3-18 RJ45 sockets

Operator Interface

When the recommended communication cable is used (refer to the Appendix for the ordering number), correct connection between the SIPROTEC 4 device and the PC or laptop is automatically ensured.

Service Interface

Check the data connection if the service interface (Port C) is used to communicate with the device via fixed wiring or a modem. If the service port is used as input for one or two RTD boxes, verify the interconnection according to one of the connection examples given in Appendix A.3.

System Interface

When a serial interface of the device is connected to a control center, the data connection must be checked. A visual check of the assignment of the transmit and receive channels is important. With RS232 and fiber optic interfaces, each connection is dedicated to one transmission direction. For that reason the data output of one device must be connected to the data input of the other device and vice versa.

With data cables, the connections are designated according to DIN 66020 and ISO 2110:

- TxD = Data output
- RxD = Data input
- $\overline{\text{RTS}}$ = Request to send
- CTS = Clear to send
- GND = Signal/Chassis Ground

The cable shield is to be grounded at **both ends**. For extremely EMC-prone environments, the GND may be connected via a separate individually shielded wire pair to improve immunity to interference.

Table 3-14 Connector Assignment at the Various Interfaces

Pin-Nr.	RS232	RS485	Profibus FMS Slave, RS485	Modbus RS485	EN 100 elektr. RJ45	IEC 60870-5-103 redundant RS485 (RJ45)
			Profibus DP Slave, RS485	DNP 3.0 RS485		
1	Shield (with shield ends electrically connected)				Tx+	B/B' (RxD/TxD-P)
2	RxD	-	-	-	Tx-	A/A' (RxD/TxD-N)
3	TxD	A/A' (RxD/TxD-N)	B/B' (RxD/TxD-P)	A	Rx+	
4	-	-	CNTR-A (TTL)	RTS (TTL Pegel)	-	
5	GND	C/C' (GND)	C/C' (GND)	GND1	-	
6	-	-	+5 V (max. load < 100 mA)	VCC1	Rx-	
7	RTS	- ¹⁾	-	-	-	
8	CTS	B/B' (RxD/TxD-P)	A/A' (RxD/TxD-N)	B	-	
9	-	-	-	-	not prived	

¹⁾ Pin 7 also carries the RTS signal with RS232 level when operated as RS485 interface. Pin 7 must therefore not be connected.

Termination

The RS485 interface is capable of half-duplex service with the signal A/A' and B/B' with a common relative potential C/C' (GND). Verify that only the last device on the bus has the terminating resistors connected, and that the other devices on the bus do not. The jumpers for the terminating resistors are located on the interface module RS485 (see Figure 3-10) or Profibus RS485 (see Figure 3-12). The terminating resistors can also be connected externally (e.g. to the connection module, as illustrated in Figure 3-14). In this case, the terminating resistors located on the module must be disconnected.

If the bus is extended, make sure again that only the last device on the bus has the terminating resistors switched-in, and that all other devices on the bus do not.

Time Synchronization Interface

It is optionally possible to process 5 V-, 12 V- or 24 V- time synchronization signals, provided that they are carried to the inputs named in the following table.

Table 3-15 D-SUB socket assignment of the time synchronization interface

Pin No.	Description	Signal Meaning
1	P24_TSIG	Input 24 V
2	P5_TSIG	Input 5 V
3	M_TSIG	Return Line
4	– ¹⁾	– ¹⁾
5	SHIELD	Shield Potential
6	–	–
7	P12_TSIG	Input 12 V
8	P_TSYNC ¹⁾	Input 24 V ¹⁾
9	SHIELD	Shield Potential

¹⁾ assigned, but not used

Fiber-optic Cables



WARNING!

Laser Radiation!

Do not look directly into the fiber-optic elements!

Signals transmitted via optical fibers are unaffected by interference. The fibers guarantee electrical isolation between the connections. Transmit and receive connections are represented by symbols.

The standard setting of the character idle state for the optical fiber interface is „Light off“. If the character idle state is to be changed, use the operating program DIGSI as described in the SIPROTEC 4 System Description.

RTD-Box (Resistance Temperature Detector)

If one or two 7XV566 temperature meters are connected, check their connections to the port (port C).

Verify also the termination: The terminating resistors must be connected to 7SJ61 (see margin heading „Termination“).

For further information refer to the operating manual of 7XV5662-xAD. Check the transmission settings at the temperature meter. Besides the baud rate and the parity the bus number is also important.

For connection of RTD-box(es) proceed as follows:

- For connection of **1** RTD box 7XV5662-xAD: Bus number = **0** (to be set on 7XV5662-xAD).
- For the connection of **2** RTD boxes 7XV5662-xAD: bus number = **1** for the 1st RTD box (to be set on 7XV5662-xAD for RTD 1 to 6), bus number = **2** for the 2nd RTD box (to be set on 7XV5662-xAD for RTD 7 to 12).

Please observe that detector input 1 (RTD1) of the first RTD-box is assigned for ambient or coolant temperature of the overload protection.

3.2.2 Checking System Connections



WARNING!

Warning of dangerous voltages

Non-observance of the following measures can result in death, personal injury or substantial property damage.

Therefore, only qualified people who are familiar with and adhere to the safety procedures and precautionary measures should perform the inspection steps.



Caution!

Take care when operating the device without a battery on a battery charger.

Non-observance of the following measures can lead to unusually high voltages and consequently, the destruction of the device.

Do not operate the device on a battery charger without a connected battery. (For limit values see also Technical Data, Section 4.1).

Before the device is energized for the first time, it should be in the final operating environment for at least 2 hours to equalize the temperature, to minimize humidity and to avoid condensation. Connections are checked with the device at its final location. The plant must first be switched off and grounded.

Proceed as follows in order to check the system connections:

- Protective switches (e.g. test switches, fuses, or miniature circuit breakers) for the power supply must be opened.
- Check the continuity of all current transformer connections against the system and connection diagrams:
 - Are the current transformers grounded properly?
 - Are the polarities of the current transformers the same?
 - Is the phase relationship of the current transformers correct?
 - Is the polarity for current input I_4 correct (if used)?
- If check switches are used for secondary testing of the device, their functions also must be checked, in particular that in the "check" setting the current transducer secondary lines are automatically shorted.
- The short-circuit feature of the current circuits of the device are to be checked. This may be performed with an ohmmeter or other test equipment for checking continuity. Make sure that terminal continuity is not wrongly simulated in reverse direction via current transformers or their short-circuiters.
 - Remove the front panel of the device
 - Remove the ribbon cable connected to the I/O board with the measured current inputs (on the front side it is the right printed circuit board in Figure 3-3). Then remove the printed circuit board so that there is no longer any contact with the plug-in terminal of the housing.
 - At the terminals of the device, check continuity for each pair of terminals that receives current from the CTs.
 - Firmly re-insert the I/O board. Carefully connect the ribbon cable. Do not bend any connector pins! Do not use force!
 - At the terminals of the device, again check continuity for each pair of terminals that receives current from the CTs.
 - Attach the front panel and tighten the screws.

- Connect an ammeter in the supply circuit of the power supply. A range of about 2.5 A to 5 A for the meter is appropriate.
- Switch on m.c.b. for auxiliary voltage (supply protection), check the voltage level and, if applicable, the polarity of the voltage at the device terminals or at the connection modules.
- The current consumption should correspond to the power input in neutral position of the device. The measured steady state current should be insignificant. Transient movement of the ammeter merely indicates the charging current of capacitors.
- Remove the voltage from the power supply by opening the supply circuit of the power supply.
- Disconnect the measuring test equipment; restore the normal power supply connections.
- Check the trip and close circuits to the power system circuit breakers.
- Verify that the control wiring to and from other devices is correct.
- Check the signalling connections.
- Remove the voltage from the power supply by closing the supply circuit of the power supply.

3.3 Commissioning



WARNING!

Warning of dangerous voltages when operating an electrical device

Non-observance of the following measures can result in death, personal injury or substantial property damage.

Only qualified people shall work on and around this device. They must be thoroughly familiar with all warnings and safety notices in this instruction manual as well as with the applicable safety steps, safety regulations, and precautionary measures.

Before making any connections, the device must be grounded at the protective conductor terminal.

Hazardous voltages can exist in all switchgear components connected to the power supply and to measurement and test circuits.

Hazardous voltages can be present in the device even after the power supply voltage has been removed (capacitors can still be charged).

After switching off the auxiliary voltage, wait a minimum of 10 seconds before reconnecting this voltage so that steady conditions can be established.

The limit values given in Technical Data (Chapter 4) must not be exceeded, neither during testing nor during commissioning.

When testing the device with secondary test equipment, make sure that no other measurement quantities are connected and that the trip and close circuits to the circuit breakers and other primary switches are disconnected from the device.



DANGER!

Hazardous voltages during interruptions in secondary circuits of current transformers

Non-observance of the following measure will result in death, severe personal injury or substantial property damage.

Short-circuit the current transformer secondary circuits before current connections to the device are opened.

Switching operations have to be carried out during commissioning. A prerequisite for the prescribed tests is that these switching operations can be executed without danger. They are accordingly not intended for operational checks.



WARNING!

Warning of dangers evolving from improper primary tests

Non-observance of the following measures can result in death, personal injury or substantial property damage.

Primary tests are only allowed to be carried out by qualified personnel, who are familiar with the commissioning of protection systems, the operation of the plant and the safety rules and regulations (switching, grounding, etc.).

3.3.1 Test Mode and Transmission Block

Activation and Deactivation

If the device is connected to a central or main computer system via the SCADA interface, then the information that is transmitted can be influenced. This is only possible with some of the protocols available (see Table „Protocol-dependent functions“ in the Appendix A.6).

If the **test mode** is switched on, the messages sent by a SIPROTEC 4 device to the main system has an additional test bit. This bit allows the messages to be recognized as not resulting from actual faults. Furthermore, it can be determined by activating the **transmission block** that no annunciations are transmitted via the system interface during test mode.

The SIPROTEC 4 System Manual describes in detail how to activate and deactivate the test mode and blocked data transmission. Please note that when DIGSI is being used for device editing, the program must be in the **online** operating mode for the test features to be used.

3.3.2 Testing the System Interface

Prefacing Remarks

If the device features a system interface and this is used to communicate with the control center, the DIGSI device operation can be used to test if messages are transmitted correctly. This test option should however definitely not be used while the device is in „real“ operation.



DANGER!

Danger evolving from operating the equipment (e.g. circuit breakers, disconnectors) by means of the test function

Non-observance of the following measure will result in death, severe personal injury or substantial property damage.

Equipment used to allow switching such as circuit breakers or disconnectors is to be checked only during commissioning. Do not under any circumstances check them by means of the test function during real operation by transmitting or receiving messages via the system interface.



Note

After termination of the system interface test the device will reboot. Thereby, all annunciation buffers are erased. If required, these buffers should be extracted with DIGSI prior to the test.

The interface test is carried out using DIGSI in the Online operating mode:

- Open the **Online** directory by double-clicking; the operating functions for the device appear.
- Click on **Test**; the function selection appears in the right half of the screen.
- Double-click **Generate Indications** in the list view. The **Generate Indications** dialog box opens (see following figure).

Structure of the Test Dialog Box

In the column **Indication** the display texts of all indications are displayed which were allocated to the system interface in the matrix. In the column **SETPOINT Status** the user has to define the value for the messages to be tested. Depending on annunciation type, several input fields are offered (e.g. message „ON“ / message „OFF“). By clicking on one of the fields you can select the desired value from the pull-down menu.

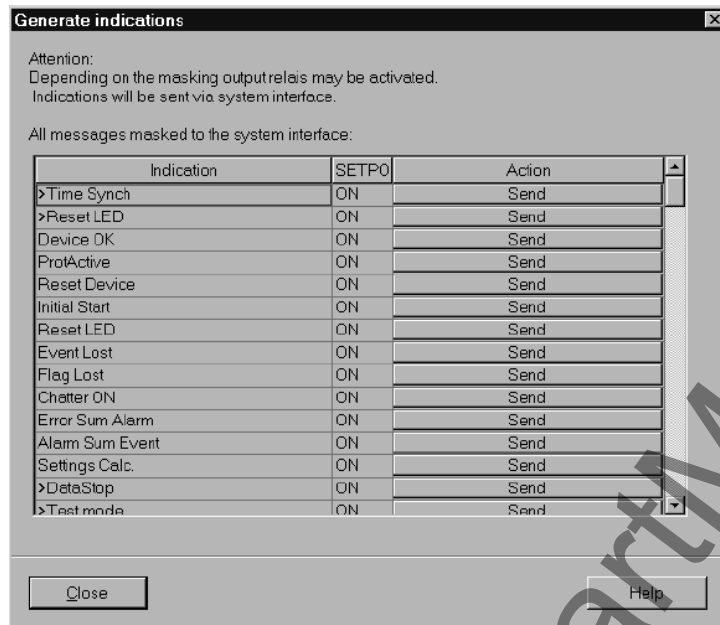

Figure 3-19 System interface test with the dialog box: Creating messages - example

Changing the Operating State

When clicking one of the buttons in the column **Action** for the first time, you will be prompted for the password no. 6 (for hardware test menus). After correct entry of the password, individual annunciations can be initiated. To do so, click on the button **Send** on the corresponding line. The corresponding message is issued and can be read out either from the event log of the SIPROTEC 4 device or from the substation control system.

As long as the window is open, further tests can be performed.

Test in Message Direction

For all information that is transmitted to the central station, test the options in the list which appears in **SETPOINT Status**:

- Make sure that each checking process is carried out carefully without causing any danger (see above and refer to DANGER!)
- Click on Send in the function to be tested and check whether the transmitted information reaches the central station and shows the desired reaction. Data which are normally linked via binary inputs (first character „>“) are likewise indicated to the central power system with this procedure. The function of the binary inputs itself is tested separately.

Exiting the Test Mode

To end the System Interface Test, click on **Close**. The device is briefly out of service while the start-up routine is executed. The dialog box closes.

Test in Command Direction

The information transmitted in command direction must be indicated by the central station. Check whether the reaction is correct.

3.3.3 Checking the Status of Binary Inputs and Outputs

Prefacing Remarks

The binary inputs, outputs, and LEDs of a SIPROTEC 4 device can be individually and precisely controlled in DIGSI. This feature is used to verify control wiring from the device to plant equipment (operational checks) during commissioning. This test option should however definitely not be used while the device is in „real“ operation.



DANGER!

Danger evolving from operating the equipment (e.g. circuit breakers, disconnectors) by means of the test function

Non-observance of the following measure will result in death, severe personal injury or substantial property damage.

Equipment used to allow switching such as circuit breakers or disconnectors is to be checked only during commissioning. Do not under any circumstances check them by means of the test function during real operation by transmitting or receiving messages via the system interface.



Note

After finishing the hardware tests, the device will reboot. Thereby, all annunciation buffers are erased. If required, these buffers should be read out with DIGSI and saved prior to the test.

The hardware test can be carried out using DIGSI in the Online operating mode:

- Open the **Online** directory by double-clicking; the operating functions for the device appear.
- Click on **Test**; the function selection appears in the right half of the screen.
- Double-click in the list view on **Hardware Test**. The dialog box of the same name opens (see the following figure).

Structure of the Test Dialog Box

The dialog box is classified into three groups: **BI** for binary inputs, **REL** for output relays, and **LED** for light-emitting diodes. On the left of each of these groups is an accordingly labelled button. By double-clicking a button, information regarding the associated group can be shown or hidden.

In the column **Status** the present (physical) state of the hardware component is displayed. Indication is made by symbols. The physical actual states of the binary inputs and outputs are indicated by an open or closed switch symbol, the LEDs by a dark or illuminated LED symbol.

The opposite state of each element is displayed in the column **Scheduled**. The display is made in plain text.

The right-most column indicates the commands or messages that are configured (masked) to the hardware components.

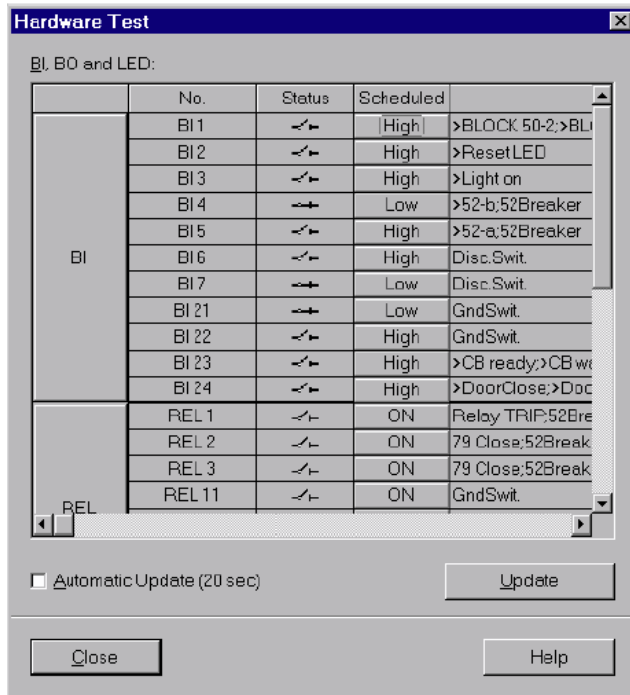

Figure 3-20 Test of the binary inputs/outputs — example

Changing the Operating State

To change the status of a hardware component, click on the associated button in the **Scheduled** column.

Password No. 6 (if activated during configuration) will be requested before the first hardware modification is allowed. After entry of the correct password a status change will be executed. Further status changes remain possible while the dialog box is open.

Test of the Output Relays

Each individual output relay can be energized allowing to check the wiring between the output relay of the 7SJ61 and the system, without having to generate the message that is assigned to the relay. As soon as the first status change for any one of the output relays is initiated, all output relays are separated from the internal device functions, and can only be operated by the hardware test function. This for example means that a switching command coming from a protection function or a control command from the operator panel to an output relay cannot be executed.

Proceed as follows in order to check the output relay :

- Ensure that the switching of the output relay can be executed without danger (see above under DANGER!).
- Each output relay must be tested via the corresponding **Scheduled**-cell in the dialog box.
- Finish the testing (see margin title below „Exiting the Test Mode“), so that during further testings no unwanted switchings are initiated.

Test of the Binary Inputs

To test the wiring between the plant and the binary inputs of the 7SJ61 the condition in the plant which initiates the binary input must be generated and the response of the device checked.

To do so, the dialog box **Hardware Test** must be opened again to view the physical state of the binary inputs. The password is not yet required.

Proceed as follows in order to check the binary inputs:

- Activate each of function in the system which causes a binary input to pick up.
- Check the reaction in the **Status** column of the dialog box. To do this, the dialog box must be updated. The options may be found below under the margin heading „Updating the Display“
- Finish the testing (see margin heading below „Exiting the Test Mode“).

If ,however, the effect of a binary input must be checked without carrying out any switching in the plant, it is possible to trigger individual binary inputs with the hardware test function. As soon as the first state change of any binary input is triggered and the password No. 6 has been entered, all binary inputs are separated from the plant and can only be activated via the hardware test function.

Test of the LEDs

The LEDs may be tested in a similar manner to the other input/output components. As soon as the first state change of any LED has been triggered, all LEDs are separated from the internal device functionality and can only be controlled via the hardware test function. This means e.g. that no LED is illuminated anymore by a protection function or by pressing the LED reset button.

Updating the Display

As the **Hardware Test** dialog opens, the operating states of the hardware components which are current at this time are read in and displayed.

An update is made:

- for each hardware component, if a command to change the condition is successfully performed,
- for all hardware components if the **Update** button is clicked,
- for all hardware components with cyclical updating (cycle time is 20 seconds) if the **Automatic Update (20sec)** field is marked.

Exiting the Test Mode

To end the hardware test, click on **Close**. The dialog box is closed. The device becomes unavailable for a brief start-up period immediately after this. Then all hardware components are returned to the operating conditions determined by the plant settings.

3.3.4 Tests for Circuit Breaker Failure Protection

General

If the device provides a breaker failure protection and if this is used, the integration of this protection function in the system must be tested under practical conditions.

Due to the variety of application options and the available system configurations, it is not possible to make a detailed description of the necessary tests. It is important to observe local conditions and protection and system drawings.

Before starting the circuit breaker tests it is recommended to isolate the circuit breaker of the tested feeder at both ends, i.e. line isolators and busbar isolators should be open so that the breaker can be operated without risk.

Caution!



Also for tests on the local circuit breaker of the feeder a trip command to the surrounding circuit breakers can be issued for the busbar.

Non-observance of the following measure can result in minor personal injury or property damage.

Therefore, primarily it is recommended to interrupt the tripping commands to the adjacent (busbar) breakers, e.g. by interrupting the corresponding pickup voltages.

Before the breaker is finally closed for normal operation, the trip command of the feeder protection routed to the circuit breaker must be disconnected so that the trip command can only be initiated by the breaker failure protection.

Although the following lists do not claim to be complete, they may also contain points which are to be ignored in the current application.

Auxiliary Contacts of the CB

The circuit breaker auxiliary contact(s) form an essential part of the breaker failure protection system in case they have been connected to the device. Make sure the correct assignment has been checked.

External Initiation Conditions

If the breaker failure protection can be started by external protection devices, the external start conditions must be checked.

In order for the breaker failure protection to be started, a current must flow at least via the monitored phase. This may be a secondary injected current.

- Start by trip command of the external protection: binary input functions „>50BF ext SRC“ (FNo 1431) (in spontaneous or fault annunciations).
- After every start, the message „50BF ext Pickup“ (FNo 1457) must appear in the spontaneous or fault annunciations.
- After time expiration **TRIP - Timer** (address 7005) tripping command of the circuit breaker failure protection.

Switch off test current.

If start is possible without current flow:

- Closing the circuit breaker to be monitored to both sides with the disconnecter switches open.
- Start by trip command of the external protection: Binary input functions „>50BF ext SRC“ (FNo 1431) (in spontaneous or fault annunciations).
- After every start, the message „50BF ext Pickup“ (FNo 1457) must appear in the spontaneous or fault annunciations.
- After time expiration **TRIP - Timer** (address 7005) tripping command of the circuit breaker failure protection.

Open the circuit breaker again.

Busbar Tripping

For testing the distribution of the trip commands in the substation in the case of breaker failures it is important to check that the trip commands to the adjacent circuit breakers is correct.

The adjacent circuit breakers are those of all feeders which must be tripped in order to ensure interruption of the fault current should the local breaker fail. These are therefore the circuit breakers of all feeders which feed the busbar or busbar section to which the feeder with the fault is connected.

A general detailed test guide cannot be specified because the layout of the adjacent circuit breakers largely depends on the system topology.

In particular with multiple busbars, the trip distribution logic for the adjacent circuit breakers must be checked. Here it should be checked for every busbar section that all circuit breakers which are connected to the same busbar section as the feeder circuit breaker under observation are tripped, and no other breakers.

Termination

All temporary measures taken for testing must be undone, e.g. especially switching states, interrupted trip commands, changes to setting values or individually switched off protection functions.

3.3.5 Testing User-Defined Functions

CFC Logic

The device has a vast capability for allowing functions to be defined by the user, especially with the CFC logic. Any special function or logic added to the device must be checked.

Of course, general test procedures cannot be given. Configuration of these functions and the target conditions must be actually known beforehand and tested. Possible interlocking conditions of switching devices (circuit breakers, disconnectors, ground switch) are of particular importance. They must be observed and tested.

3.3.6 Current and Phase Rotation Testing

≥ 10 % of Load Current

The connections of the current and voltage transformers are tested using primary quantities. Secondary load current of at least 10 % of the nominal current of the device is necessary. The line is energized and will remain in this state during the measurements.

With proper connections of the measuring circuits, none of the measured-values supervision elements in the device should pick up. If an element detects a problem, the causes which provoked it may be viewed in the Event Log.

If current sum errors are found, check the matching factors.

Messages from the symmetry monitoring could occur because there actually are asymmetrical conditions in the network. If these asymmetrical conditions are normal service conditions, the corresponding monitoring functions should be made less sensitive.

Values

The currents can be seen in the display field at the front of the device or a PC via the operator interface. They can be compared to the quantities measured by an independent source, as primary and secondary quantities.

If the measured values are not plausible, the connection must be checked and corrected after the line has been isolated and the current transformer circuits have been short-circuited. The measurements must then be repeated.

Phase Rotation

The phase rotation must correspond to the configured phase rotation, in general a clockwise phase rotation. If the system has an anti-clockwise phase rotation, this must have been considered when the power system data was set (address 209 **PHASE SEQ.**). If the phase rotation is incorrect, the alarm (FNo) is generated. The measured value phase allocation must be checked and corrected, if required, after the line has been isolated and current transformers have been short-circuited. The measurement must then be repeated.

3.3.7 Test for High Impedance Protection

Polarity of Transformers

When the device is used for high-impedance protection, the current at I_N or I_{NS} is equivalent to the fault current in the protected object. It is essential in this case that all current transformers feeding the resistor whose current is measured at $I_{N(S)}$ have the same polarity. The test currents used for this are through currents. Each CT must be included in a measurement. The current at $I_{N(S)}$ may never exceed half the pickup value of the single-phase time overcurrent protection.

3.3.8 Testing the Reverse Interlocking Scheme

(only if used)

Testing reverse interlocking is available if at least one of the binary inputs available is configured for this purpose (e.g. presetting of binary input BI1 „>BLOCK 50-2“ and „>BLOCK 50N-2“ to open circuit system). Tests can be performed with phase currents or ground current. For ground current the corresponding ground current settings apply.

Please note that the blocking function can either be configured for the pickup current connected (open circuit system) or the pickup current missing (closed circuit system). For open circuit system the following tests are to be proceeded:

The feeder protection relays of all associated feeders must be in operation. At the beginning no auxiliary voltage is fed to the reverse interlocking system.

A test current higher than the pickup values of **50-2 PICKUP** and **50-1 PICKUP** or **51 PICKUP** is set. As a result of the missing blocking signal, the protection function trips after (short) time delay **50-2 DELAY**.

Caution!



Tests with currents that exceed more than 4 times the nominal device current cause an overload of the input circuits.

Perform test only for a short time (see Technical Data, Section 4.1). Afterwards the device has to cool off !

The direct voltage for reverse interlocking is now switched on to the line. The precedent test is repeated, the result will be the same.

Subsequently, at each of the protection devices of the feeders, a pickup is simulated. Meanwhile, another fault is simulated for the protection function of the infeed, as described before. Tripping is performed within time **50-1 DELAY** (longer time period) (with definite time overcurrent protection) or according to characteristic (with inverse time overcurrent protection).

These tests also check the proper functioning of the wiring for reverse interlocking.

3.3.9 Checking the Temperature Measurement via RTD-Box

After the termination of the RS485 port and the setting of the bus address have been verified according to Section 3.2, the measured temperature values and thresholds can be checked.

If temperature sensors are used with 2-phase connection you must first determine the line resistance for the temperature detector being short-circuited. Select mode 6 at the RTD-Box and enter the resistance value you have determined for the corresponding sensor (range: 0 to 50.6 Ω).

When using the preset 3-phase connection for the temperature detectors no further entry must be made.

For checking the measured temperature values, the temperature detectors are replaced by adjustable resistors (e.g. precision resistance decade) and the correct assignment of the resistance value and the displayed temperature for 2 or 3 temperature values from the following table are verified.

Table 3-16 Assignment of the resistance value and the temperature of the sensors

Temperature in °C	Temperature in °F	Ni 100 DIN 43760	Ni 120 DIN 34760	Pt 100 IEC 60751
-50	-58	74.255	89.106	80.3062819
-40	-40	79.1311726	94.9574071	84.270652
-30	-22	84.1457706	100.974925	88.2216568
-20	-4	89.2964487	107.155738	92.1598984
-10	14	94.581528	113.497834	96.085879
0	32	100	120	100
10	50	105.551528	126.661834	103.902525
20	68	111.236449	133.483738	107.7935
30	86	117.055771	140.466925	111.672925
40	104	123.011173	147.613407	115.5408
50	122	129.105	154.926	119.397125
60	140	135.340259	162.408311	123.2419
70	158	141.720613	170.064735	127.075125
80	176	148.250369	177.900442	130.8968
90	194	154.934473	185.921368	134.706925
100	212	161.7785	194.1342	138.5055
110	230	168.788637	202.546364	142.292525
120	248	175.971673	211.166007	146.068
130	266	183.334982	220.001979	149.831925
140	284	190.88651	229.063812	153.5843
150	302	198.63475	238.3617	157.325125
160	320	206.58873	247.906476	161.0544
170	338	214.757989	257.709587	164.772125
180	356	223.152552	267.783063	168.4783
190	374	231.782912	278.139495	172.172925
200	392	240.66	288.792	175.856
210	410	249.79516	299.754192	179.527525
220	428	259.200121	311.040145	183.1875
230	446	268.886968	322.664362	186.835925
240	464	278.868111	334.641733	190.4728
250	482	289.15625	346.9875	194.098125

Temperature thresholds that are configured in the protection device can be checked by slowly approaching the resistance value.

3.3.10 Trip/Close Tests for the Configured Operating Devices

Control by Local Command

If the configured operating devices were not switched sufficiently in the hardware test already described, all configured switching devices must be switched on and off from the device via the integrated control element. The feedback information of the circuit breaker position injected via binary inputs is read out at the device and compared with the actual breaker position.

The switching procedure is described in the SIPROTEC 4 System Description. The switching authority must be set according to the command source used. The switching mode can be selected from interlocked and non-interlocked switching. Please note that non-interlocked switching can be a safety hazard.

Control by Protective Functions

For OPEN-commands sent to the circuit breaker please take into consideration that if the internal or external automatic reclosure function is used a TRIP-CLOSE test cycle is initiated.



DANGER!

A test cycle successfully started by the automatic reclosure function can lead to the closing of the circuit breaker !

Non-observance of the following statement will result in death, severe personal injury or substantial property damage.

Be fully aware that OPEN-commands sent to the circuit breaker can result in a trip-close-trip event of the circuit breaker by an external reclosing device.

Control from a Remote Control Center

If the device is connected to a remote substation via a system interface, the corresponding switching tests may also be checked from the substation. Please also take into consideration that the switching authority is set in correspondence with the source of commands used.

3.3.11 Creating Oscillographic Recordings for Tests

General

In order to be able to test the stability of the protection during switchon procedures also, switchon trials can also be carried out at the end. Oscillographic records obtain the maximum information about the behaviour of the protection.

Requirements

To be able to trip an oscillographic recording, parameter **Osc Fault Rec.** must be configured to **Enabled** in the **Functional Scope**. Apart from the capability of storing fault recordings via pickup of the protection function, the 7SJ61 also has the capability of initiating a measured value recording via the operator program DIGSI, the serial interface or binary input. In the latter case, the information „>Trig.Wave.Cap.“ must be allocated to a binary input. Triggering for the oscillographic recording then occurs, for instance, via the binary input when the protection object is energized.

Those that are externally triggered (that is, without a protective element pickup) are processed by the device as a normal oscillographic record. For each oscillographic record a fault record is created which is given its individual number to ensure that assignment can be made properly. However, these recordings are not displayed in the fault indication buffer, as they are not fault events.

Triggering Oscillographic Recording

To trigger test measurement recording with DIGSI, click on **Test** in the left part of the window. Double click the entry **Test Wave Form** in the list of the window.

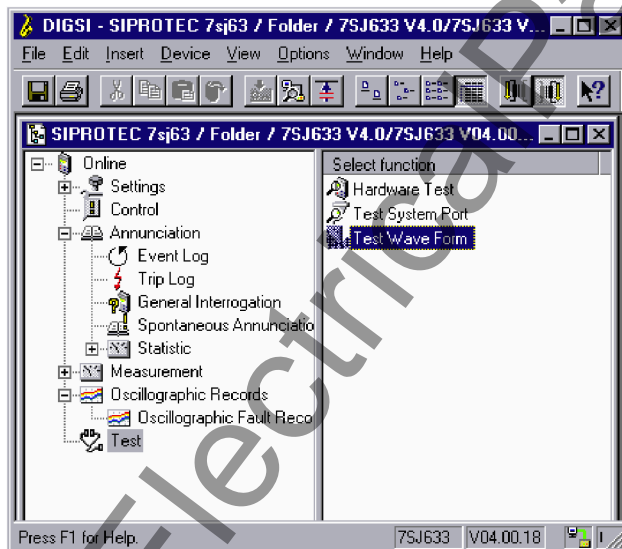

Figure 3-21 Triggering oscillographic recording with DIGSI®

Oscillographic recording is started immediately. During recording, a report is given in the left part of the status bar. Bar segments additionally indicate the progress of the procedure.

The SIGRA or the Comtrade Viewer program is required to view and analyse the oscillographic data.

3.4 Final Preparation of the Device

Firmly tighten all screws. Tighten all terminal screws, including those that are not used.

Caution!



Inadmissible Tightening Torques

Non-observance of the following measure can result in minor personal injury or property damage.

The tightening torques must not be exceeded as the threads and terminal chambers may otherwise be damaged!

The settings should be checked again, if they were changed during the tests. Check if all protection, control and auxiliary functions to be found with the configuration parameters are set correctly (Section 2.1.1, Functional Scope) and all desired functions are set to **ON**. Keep a copy of all setting values on a PC.

Check the internal clock of the device. If necessary, set or synchronize the clock if it is not automatically synchronized. For assistance, refer to the SIPROTEC 4 System Description.

The annunciation buffers are deleted under **MAIN MENU** → **Annunciations** → **Set/Reset**, so that future information will only apply to actual events and states (see also SIPROTEC 4 System Description). The counters in the switching statistics should be reset to the values that were existing prior to the testing (see also SIPROTEC 4 System Description).

Reset the counter of the operational measured values (e.g. operation counter, if available) under **MAIN MENU** → **Measured Values** → **Reset** (also see SIPROTEC 4 System Description).

Press the Esc key (several times if necessary), to return to the default display. The default display appears in the display box (e.g. the display of operational measured values).

Clear the LEDs on the front panel of the device by pressing the LED key, so that they show only real events and states in the future. In this context, also output relays probably memorized are reset. Pressing the LED key also serves as a test for the LEDs on the front panel because they should all light when the button is pushed. Any LEDs that are lit after the clearing attempt are displaying actual conditions.

The green „RUN“ LED must light up, whereas the red „ERROR“ must not light up.

Close the protective switches. If test switches are available, then these must be in the operating position.

The device is now ready for operation.



www.ElectricalPartManuals.com

Technical Data

This chapter provides the technical data of the device SIPROTEC 7SJ61 and its individual functions, including the limit values that may not be exceeded under any circumstances. The electrical and functional data for the maximum functional scope are followed by the mechanical specifications with dimensioned drawings.

4.1	General Device Data	306
4.2	Definite-Time Overcurrent Protection 50(N)	318
4.3	Inverse-Time Overcurrent Protection 51(N)	320
4.4	Inrush Restraint	331
4.5	DynamiC Cold Load Pickup	332
4.6	Single-phase Overcurrent Protection	333
4.7	Negative Sequence Protection 46-1, 46-2	334
4.8	Negative Sequence Protection 46-TOC	335
4.9	Motor Starting Protection 48	341
4.10	Motor Restart Inhibit 66	342
4.11	Load Jam Protection	343
4.12	Thermal Overload Protection 49	344
4.13	Ground Fault Protection 50N(s), 51N(s)	346
4.14	Intermittent Ground Fault Protection	350
4.15	Automatic Reclosing System 79	351
4.16	Breaker Failure Protection 50BF	352
4.17	Flexible Protection Functions	353
4.18	Temperature Detection via RTD Boxes	355
4.19	User-defined Functions (CFC)	356
4.20	Additional Functions	361
4.21	Breaker Control	365
4.22	Dimensions	366

4.1 General Device Data

4.1.1 Analog Inputs

Current Inputs

Nominal Frequency	f_{Nom}	50 Hz or 60 Hz	(adjustable)
Nominal Current	I_{Nom}	1 A or 5 A	
Ground Current, Sensitive	I_{Ns}	\leq linear range 1.6 A ¹⁾	
Burden per Phase and Ground Path - at $I_{Nom} = 1$ A - at $I_{Nom} = 5$ A - for sensitive ground fault detection at 1 A		Approx. 0.05 VA Approx. 0.3 VA Approx. 0.05 VA	
Current overload capability - Thermal (rms) - Dynamic (peak value)		100· I_{Nom} for 1 s 30· I_{Nom} for 10 s 4· I_{Nom} continuous 250· I_{Nom} (half-cycle)	
Current overload capability for high-sensitivity input I_{Ns} ¹⁾			
- Thermal (rms) - Dynamic (peak value)		300 A for 1 s 100 A for 10 s 15 A continuous 750 A (half-cycle)	

¹⁾ only in models with input for sensitive ground fault detection (see ordering data in Appendix A.1)

4.1.2 Auxiliary Voltage

DC Voltage

Voltage Supply via Integrated Converter		
Rated auxiliary DC V_{Aux}	24/48 VDC	60/110/125 VDC
Permissible Voltage Ranges	19 to 58 VDC	48 to 150 VDC
Rated auxiliary DC V_{Aux}	110/125/220/250 VDC	
Permissible Voltage Ranges	88 to 300 VDC	
Permissible AC ripple voltage, Peak to Peak, IEC 60 255-11	15 % of the auxiliary voltage	
Power Input	Quiescent	Approx. 3 W
	Energized	Approx. 7 W
Bridging Time for Failure/Short Circuit, IEC 60255-11 (in not energized operation)	\geq 50 ms at $V \geq 110$ VDC	
	\geq 20 ms at $V \geq 24$ VDC	

Alternating Voltage

Voltage supply using integrated converter		
Rated auxiliary AC V_{Aux}	115 VAC	230 VAC
Permissible Voltage Ranges	92 to 132 VAC	184 to 265 VAC
Power consumption, quiescent	Approx. 3 VA	Approx. 3 VA
Power consumption, energized	Approx. 7 VA	Approx. 7 VA
Bridging time for failure/short circuit (in not energized operation)	≥ 200 ms	

4.1.3 Binary Inputs and Outputs

Binary Inputs

Variant	Quantity	
7SJ610*–	3 (configurable)	
7SJ611*–	8 (configurable)	
7SJ612*–	11 (configurable)	
Rated Voltage Range	24 VDC to 250 VDC, bipolar	
Current Consumption (independent of the control voltage)	Approx. 1.8 mA	
Pickup time	Approx. 4 ms	
Switching Thresholds	Switching Thresholds, adjustable voltage range with jumpers	
For Nominal Voltages	24/48/60/110/125 VDC	V high ≥ 19 VDC V low ≤ 10 VDC
For Nominal Voltages	110/125/220/250 VDC	V high ≥ 88 VDC V low ≤ 44 VDC
for nominal voltages (only for modules with 3 switching thresholds)	220/250 VDC and 115/230 VAC	V high ≤ 176 VDC V low ≤ 88 VDC
Maximum admissible voltage	300 VDC	
Impulse Filter on Input	220 nF Coupling Capacitor at 220 V with recovery time > 60 ms	

Output Relays

Output Relay for Commands/Annunciations, Alarm Relay *)		
Number and Information	According to the Order Variant (allocatable); Values in (): up to release .../DD	
Order variant	NO contact	NO/NC, switch selectable
7SJ610*–	2 (4)	3 (1)
7SJ611*–	6 (8)	3 (1)
7SJ612*–	4 (6)	3 (1)
Switching capability CLOSE	1000 W/VA	
Switching capability TRIP	30 VA 40 W resistive 25 W at L/R ≤ 50 ms	
Switching voltage	250 VDC / 250 VAC	
Admissible current per contact (continuous)	5 A	
Adm. current per contact (close and hold)	30 A for 0.5 s (NO contact)	
Total Current on common path	5 A continuous, 30 A for 0.5 s	
AC Load (it has to be taken into consideration for the dimensions of external circuits)		
Value of the ANSI capacitor: 4,70 · 10 ⁻⁹ F ± 20%	Frequency	Impedance
	50 Hz	6,77 · 10 ⁵ Ω ± 20%
	60 Hz	5,64 · 10 ⁵ Ω ± 20%
*) UL-listed with the following nominal values:		
	120 VAC	Pilot duty, B
	240 VAC	Pilot duty, B
	240 VAC	5 A General Purpose
	24 VDC	5 A General Purpose
	48 VDC	0.8 A General Purpose
	240 VDC	0.1 A General Purpose
	120 VAC	1/6 hp (4.4 FLA ¹⁾)
	240 VAC	1/2 hp (4.9 FLA ¹⁾)

1) FLA = "Full Load Ampere"

4.1.4 Communication Interfaces

Operating Interface

Connection	Front side, non-isolated, RS232, 9-pin DSUB port for connecting a personal computer
Operation	With DIGSI
Transmission Speed	min. 4,800 baud; max. 115,200 baud; Factory setting: 115,200 baud; Parity: 8E1
Maximum Distance of Transmission	49.2 feet (15 m)

Service / Modem Interface

	Connection	Isolated interface for data transfer
	Operation	With DIGSI
	Transmission Speed	min. 4,800 baud, max. 115,200 baud; Factory Setting 38.400 Bd
RS232/RS485		RS232/RS485 according to the order variant
	Connection for panel flush mounting housing	Rear panel, mounting location "C2", 9-pin D-subminiature female connector
	Connection for panel surface mounting housing	In the housing at the case bottom; Shielded data cable
	Test voltage	500 V; 50 Hz
RS232		
	Bridgeable distance	49.2 feet (15 m)
RS485		
	Bridgeable distance	3,280 feet (1000 m)
Fiber optic cable (FO)		
	FO connector type	ST connector
	Connection for panel flush mounting housing	Rear panel, mounting location "C"
	For panel surface mounting housing	In console housing at case bottom
	Optical wavelength	$\lambda = 820 \text{ NM}$
	Laser Class 1 according to EN 60825-1/-2	Using glass fiber 50/125 μm or using glass fiber 62.5/125 μm
	Admissible optical signal attenuation	Max. 8 dB, with glass fiber 62.5/125 μm
	Bridgeable distance	Max. 0.93 miles (1.5 km)
Character idle state	Configurable; factory setting "Light off"	

System Interface

IEC 60870-5-103 single	isolated interface for data transfer to a master terminal	
	RS232/RS485/FO according to the ordering variant	
RS232	Connection for flush-mounted casing	rear panel, mounting location „B“, 9-pole D-SUB miniature female connector
	Connection for surface-mounted casing	at the housing mounted case on the case bottom
	Test Voltage	500 VAC
	Transmission Speed	min. 1,200 Bd, max. 115,200 Bd; Factory setting 9,600 Bd
	Maximum Distance of Transmission	49.2 feet (15 m)
RS485	Connection for flush-mounted casing	rear panel, mounting location „B“, 9-pole D-SUB miniature female connector
	Connection for surface-mounted casing	at the housing mounted case on the case bottom
	Test Voltage	500 VAC
	Transmission Speed	min. 1,200 Bd, max. 115,200 Bd; Factory setting 9,600 Bd
	Maximum Distance of Transmission	max. 0.62 miles (1 km)
Fiber Optical Link (FO)	FO connector type	ST connector
	Connection for flush-mounted casing	Rear panel, mounting location „B“
	Connection for surface-mounted casing	at the housing mounted case on the case bottom
	Optical Wavelength	$\lambda = 820 \text{ nm}$
	Laser Class 1 according to	using glass fiber 50/12 μm or using glass fiber 62.5/125 μm
	Permissible Optical Link Signal Attenuation	max. 8 dB, with glass fiber 62.5/125 μm
	Transmission Speed	min. 1,200 Bd, max. 115,200 Bd; Factory setting 9,600 Bd
	Maximum Distance of Transmission	max. 0.93 miles (1.5 km)
	Character Idle State	Configurable: factory setting „Light off“
IEC 60870-5-103 redundant RS485	isolated interface for redundant data transfer to a master terminal	
	Connection for flush-mounted casing	rear panel, mounting location „B“, RJ45 sub-miniature connector
	Connection for surface-mounted casing	not available
	Test Voltage	500 V; 50 Hz
	Transmission Speed	min. 2,400 Bd, max. 57,600 Bd; Factory setting 19,200 Bd
	Bridgeable distance	max. 1 km

Profibus RS485 (FMS and DP)	Connection for flush-mounted casing	Rear panel, mounting location „B“ 9-pin D-SUB miniature connector
	Connection for surface-mounted casing	at the housing mounted case on the case bottom
	Test Voltage	500 VAC
	Transmission Speed	up to 1.5 MBd
	Maximum Distance of Transmission	3,280 ft or 1,000 m at ≤ 93.75 kBd 500 m or 1,640 ft at ≤ 187.5 kBd 200 m or 330 ft at ≤ 1.5 MBd
Profibus FO (FMS and DP)	FO connector type	ST connector Single ring / double ring according to the order for FMS; for DP only double ring available
	Connection for flush-mounted casing	Rear panel, mounting location „B“
	Connection for surface-mounted casing	in console housing on the case bottom via RS485 and external RS485/optical converter
	Transmission Speed	up to 1.5 MBd
	recommended:	> 500 kBd with normal casing $\leq 57\ 600$ Bd at detached operator panel
	Optical Wavelength	$\lambda = 820$ nm
	Laser Class 1 according to	using glass fiber 50/125 μm or using glass fiber 62.5/125 μm
	Permissible Optical Link Signal Attenuation	max. 8 dB, with glass fiber 62.5/125 μm
	Maximum Distance of Transmission	max. 0.93 miles (1.5 km)
DNP3.0 / MODBUS RS485	Connection for flush-mounted casing	Rear panel, mounting location „B“, 9-pin D-SUB miniature connector
	Connection for surface-mounted casing	at the housing mounted case on the case bottom
	Test Voltage	500 VAC
	Transmission Speed	up to 19,200 Bd
	Maximum Distance of Transmission	max. 0.62 miles (1 km)
DNP3.0 / MODBUS Fiber Optical Link	FO connector type	ST-Connector Receiver/Transmitter
	Connection for flush-mounted casing	Rear panel, mounting location „B“
	Connection for surface-mounted casing	not available
	Transmission Speed	up to 19,200 Bd
	Optical Wavelength	$\lambda = 820$ nm
	Laser Class 1 according to	using glass fiber 50/125 μm or using glass fiber 62.5/125 μm
	Permissible Optical Link Signal Attenuation	max. 8 dB, with glass fiber 62.5/125 μm
	Maximum Distance of Transmission	max. 0.93 miles (1.5 km)

Ethernet electrical (EN 100) for IEC61850 and DIGSI	Connection for flush-mounted casing	rear panel, mounting location „B“ 2 x RJ45 socket contact 100BaseT acc. to IEEE802.3
	Connection for surface-mounted casing	in console housing at case bottom
	Test voltage (reg. socket)	500 V; 50 Hz
	Transmission speed	100 MBit/s
	Bridgeable distance	65.62 feet (20 m)
Ethernet optical (EN100) for IEC61850 and DIGSI	Connection for Flush-mounted case	rear panel, mounting location "B", ST-connector 100BaseT acc. to IEEE802.3
	Connection for Surface-mounted case	(not available)
	Transmission Speed	100 MBit/s
	Optical wavelength	1300 nm
	bridgeable distance	max. 0.93 miles (1.5 km)

Time Synchronization Interface

Time Synchronization	DCF 77 / IRIG B Signal (Telegram Format IRIG-B000)
Connection for flush-mounted case	Rear panel, mounting location „A“ 9-pin D-subminiature female connector
Connection for surface mounting housing	at the double-deck terminal on the case bottom
Signal Nominal Voltages	selectable 5 V, 12 V or 24 V
Test Voltage	500 V; 50 Hz

Signal Levels and Burdens			
	Nominal Signal Voltage		
	5 V	12 V	24 V
V_{IHigh}	6.0 V	15.8 V	31 V
V_{ILow}	1.0 V at $I_{ILow} = 0.25$ mA	1.4 V at $I_{ILow} = 0.25$ mA	1.9 V at $I_{ILow} = 0.25$ mA
I_{IHigh}	4.5 mA to 9.4 mA	4.5 mA to 9.3 mA	4.5 mA to 8.7 mA
R_1	890 at $V_1 = 4$ V	1930 at $V_1 = 8.7$ V	3780 at $V_1 = 17$ V
	640 at $V_1 = 6$ V	1700 at $V_1 = 15.8$ V	3560 at $V_1 = 31$ V

4.1.5 Electrical Tests

Standards

Standards:	IEC 60255 (product standards) ANSI/IEEE Std C37.90.0/1/2 UL 508 DIN 57435 Part 303 for more standards see also individual functions
------------	---

Insulation Test

Standards:	IEC 60255-5 and IEC 60870-2-1
High Voltage Test (routine test) All circuits except power supply, Binary Inputs, Communication Interface and Time Synchronization Interfaces	2.5 kV (rms), 50 Hz
High voltage test (routine test). Auxiliary voltage and binary inputs	3.5 kV–
High Voltage Test (routine test). Only Isolated Communication and Time Synchronization Interfaces	500 V (rms), 50 Hz
Impulse Voltage Test (type test). All Circuits Except Communication and Time Synchronization Interfaces, Class III	5 kV (peak value); 1.2/50 μ s; 0.5 J; 3 positive and 3 negative impulses at intervals of 1 s

EMC Tests for Immunity (Type Tests)

Standards:	IEC 60255-6 and -22 (product standards), EN 50082-2 (Generic standard) DIN 57435 Part 303	
High Frequency Test IEC 60255-22-1, Class III and VDE 0435 Part 303, Class III	2.5 kV (Peak); 1 MHz; $\tau = 15 \mu$ s; 400 surges per s; test duration 2 s; $R_i = 200 \Omega$	
Electrostatic Discharge IEC 60255-22-2, Class IV and IEC 61000-4-2, Class IV	8 kV contact discharge; 15 kV air discharge, both polarities; 150 pF; $R_i = 330 \Omega$	
Irradiation with HF field, pulse modulated IEC 60255-22-3 (report), Class III	10 V/m; 27 MHz to 500 MHz	
Irradiation with HF field, amplitude-modulated IEC 61000-4-3, Class III	10 V/m; 80 MHz to 1000 MHz; 80 % AM; 1 kHz	
Irradiation with HF field, pulse-modulated IEC 61000-4-3/ENV 50204, Class III	10 V/m; 900 MHz: repetition frequency 200 Hz: duty cycle of 50 %	
Fast Transient Disturbance Variables / Burst IEC 60255-22-4 and IEC 61000-4-4, Class IV	4 kV; 5/50 ns; 5 kHz; burst length = 15 ms; repetition rate 300 ms; both polarities: $R_i = 50 \Omega$; test duration 1 min	
High Energy Surge Voltages (SURGE), IEC 61000-4-5 Installation Class 3	Impulse: 1.2/50 μ s	
	Auxiliary voltage	common mode: 2 kV; 12 Ω ; 9 μ F diff. mode: 1 kV; 2 Ω ; 18 μ F
	Measuring Inputs, Binary Inputs and Relay Outputs:	common mode: 2 kV; 42 Ω ; 0.5 μ F diff. mode: 1 kV; 42 Ω ; 0.5 μ F
HF on lines, amplitude-modulated IEC 61000-4-6, Class III	10 V; 150 kHz to 80 MHz; 80 % AM; 1 kHz	
Power System Frequency Magnetic Field IEC 61000-4-8; class IV IEC 60255-6	30 A/m continuous; 300 A/m for 3 s; 50 Hz 0.5 mT; 50 Hz	

Oscillatory Surge Withstand Capability IEEE Std C37.90.1	2.5 kV (peak value); 1 MHz; $\tau = 15 \mu\text{s}$; 400 surges per s; Test Duration 2 s; $R_i = 200 \Omega$
Fast Transient Surge Withstand Cap. IEEE Std C37.90.1	4 kV; 5/50 ns; repetition rate 300 ms; both polarities; Test Duration 1 min; $R_i = 50 \Omega$
Radiated Electromagnetic Interference IEEE Std C37.90.2	35 V/m; 25 MHz to 1000 MHz
Damped Oscillations IEC 60694, IEC 61000-4-12	2.5 kV (Peak Value), polarity alternating 100 kHz, 1 MHz, 10 MHz and 50 MHz, $R_i = 200 \Omega$

EMC Tests For Noise Emission (Type Test)

Standard:	EN 50081-* (technical generic standard)
Radio noise voltage to lines, only auxiliary voltage IEC-CISPR 22	150 kHz to 30 MHz Limit Class B
Interference field strength IEC-CISPR 22	30 MHz to 1000 MHz Limit Class B
Harmonic Currents on the Network Lead at 230 VAC IEC 61000-3-2	Device is to be assigned Class D (applies only for devices with > 50 VA power consumption)
Voltage fluctuations and flicker on the network in- coming feeder at 230 VAC IEC 61000-3-3	Limits are observed

4.1.6 Mechanical Stress Tests

Vibration and Shock Stress during Stationary Operation

Standards:	IEC 60255-21 and IEC 60068
Oscillation IEC 60255-21-1, Class II; IEC 60068-2-6	Sinusoidal 10 Hz to 60 Hz: ± 0.075 mm Amplitude; 60 Hz to 150 Hz: 1 g acceleration frequency sweep rate 1 Octave/min 20 cycles in 3 orthog- onal axes.
Shock IEC 60255-21-2, Class I; IEC 60068-2-27	Semi-sinusoidal 5 g acceleration, duration 11 ms, each 3 shocks (in both directions of the 3 axes)
Seismic Vibration IEC 60255-21-3, Class I; IEC 60068-3-3	Sinusoidal 1 Hz to 8 Hz: ± 3.5 mm amplitude (horizontal vectors) 1 Hz to 8 Hz: ± 1.5 mm Amplitude (vertical axis) 8 Hz to 35 Hz: 1 g acceleration (horizontal axis) 8 Hz to 35 Hz: 0.5 g acceleration (vertical axis) frequency sweep rate 1 octave/min, 1 cycle in 3 orthogonal axes

Vibration and Shock Stress during Transport

Standards:	IEC 60255-21 and IEC 60068
Oscillation IEC 60255-21-1, Class II; IEC 60068-2-6	Sinusoidal 5 Hz to 8 Hz: ± 7.5 mm amplitude; 8 Hz to 150 Hz: 2 g acceleration frequency sweep 1 octave/min 20 cycles in 3 orthogonal axes
Shock IEC 60255-21-2, Class I; IEC 60068-2-27	Semi-sinusoidal 15 g acceleration, duration 11 ms, each 3 shocks (in both directions of the 3 axes)
Continuous Shock IEC 60255-21-2, Class I; IEC 60068-2-29	Semi-sinusoidal 10 g acceleration, duration 16 ms, each 1000 shocks (in both directions of the 3 axes)

4.1.7 Climatic Stress Tests

Temperatures¹⁾

Standards:	IEC 60255-6
Type test (acc. IEC 60068-2-1 and -2, Test Bd, for 16 h)	-13°F to +185° F or -25° C to +85° C
Admissible temporary operating temperature (tested for 96 h)	-4° F to +158 °F or -20° C to +70° C (legibility of display may be restricted from +131° F or +55° C)
Recommended for permanent operation (according to IEC 60255-6)	+23° F to +131° F or -5° C to +55° C
Limit Temperatures for Storage	-13° F to +131° F or -25° C to +55° C
Limit Temperatures during Transport	-13° F to 158° F or -25° C to +70° C
STORE AND TRANSPORT OF THE DEVICE WITH FACTORY PACKAGING!	
¹⁾ UL-certified according to Standard 508 (Industrial Control Equipment):	
Limit Temperatures for Normal Operation (i.e. output relays not energized)	-4° F to +158° F or -20° C to +70° C
Limit temperatures under maximum load (max. cont. admissible input and output values)	+23° F to +131° F or -5° C to +55° C

Humidity

Permissible humidity	Mean value per year ≤ 75 % relative humidity; on 56 days of the year up to 93 % relative humidity; condensation must be avoided!
Siemens recommends that all devices be installed such that they are not exposed to direct sunlight, nor subject to large fluctuations in temperature that may cause condensation to occur.	

4.1.8 Service Conditions

<p>The device is designed for installation in normal relay rooms and plants, so that electromagnetic compatibility (EMC) is ensured if installation is done properly.</p> <p>In addition, the following is recommended:</p> <ul style="list-style-type: none"> • All contacts and relays that operate in the same cubicle, cabinet, or relay panel as the numerical protective device should, as a rule, be equipped with suitable surge suppression components. • For substations with operating voltages of 100 kV and above, all external cables should be shielded with a conductive shield grounded at both ends. For substations with lower operating voltages, no special measures are normally required. • Do not withdraw or insert individual modules or boards while the protective device is energized. In withdrawn condition, some components are electrostatically endangered; during handling the ESD standards (for Electrostatic Sensitive Devices) must be observed. They are not endangered when inserted into the case.

4.1.9 Certifications

UL listing		UL recognition	
7SJ61**_*B***_****	Models with threaded terminals	7SJ61**_*D***_****	Models with plug-in terminals
7SJ61**_*E***_****			

4.1.10 Design

Housing	7XP20
Dimensions	See dimensional drawings, Section 4.22
Weight (mass) approx.	
— Housing for panel surface mounting	9.9 lb or 4.5 kg
— Housing for panel surface mounting	8.8 lb or 4.0 kg

Protection class acc. to IEC 60529		
For surface mounting housing equipment	IP 51	
In flush mounted housing		
	Front	IP 51
	Rear	IP 50
For personal protection	IP 2x with cover cap	
UL conditions	"For use on a Flat Surface of a Type 1 Enclosure"	

4.2 Definite-Time Overcurrent Protection 50(N)

Operating Modes

Three-phase	Standard
Two-phase	Phases A and C

Measuring Technique

All elements	First harmonic, rms value (true rms)
50-3, 50N-3	Instantaneous values

Setting Ranges / Increments

Pickup current phases	for $I_{Nom} = 1$ A	0.10 A to 35.00 A or ∞ (disabled)	Increments 0.01 A
	for $I_{Nom} = 5$ A	0.50 A to 175.00 A or ∞ (disabled)	
Pickup currents ground	for $I_{Nom} = 1$ A	0.05 A to 35.00 A or ∞ (disabled)	Increments 0.01 A
	for $I_{Nom} = 5$ A	0.25 A to 175.00 A or ∞ (disabled)	
Delay times T		0.00 s to 60.00 s or ∞ (disabled)	Increments 0.01 s
Dropout delay times 50 T DROP-OUT, 50N T DROP-OUT		0.00 s to 60.00 s	Increments 0.01 s

Times

Pickup times (without inrush restraint, with restraint add 10 ms)	
First harmonic, rms value	
- for 2 x setting value	approx. 30 ms
- for 10 x setting value	Approx. 20 ms
Instantaneous value	
- for 2 x setting value	approx. 16 ms
- for 10 x setting value	approx. 16 ms
Dropout Times	
First harmonic, rms value	approx. 30 ms
Instantaneous value	approx. 40 ms

Dropout Ratio

Dropout ratio for	
- first harmonic, rms value	approx. 0,95 for $I/I_{Nom} \geq 0.3$
- instantaneous value	approx. 0,90 for $I/I_{Nom} \geq 0.3$

Tolerances

Pickup currents	2 % of setting value or 10 mA at $I_{Nom} = 1 \text{ A}$ or 50 mA at $I_{Nom} = 5 \text{ A}$
Delay times T	1 % or 10 ms

Influencing Variables for Pickup and Dropout

Power supply direct voltage in range $0.8 \leq V_{PS}/V_{PSNom} \leq 1.15$	1 %
Temperature in range $23.00 \text{ °F} (-5 \text{ °C}) \leq \Theta_{amb} \leq 131.00 \text{ °F} (55 \text{ °C})$	0.5 %/10 K
Frequency in range $0.95 \leq f/f_{Nom} \leq 1.05$	1 %
Harmonics - up to 10 % 3rd harmonic - up to 10 % 5th harmonic	1 % 1 %
Transient overreaction during fundamental harmonic measuring procedure for $t > 100 \text{ ms}$ (with full displacement)	<5 %

4.3 Inverse-Time Overcurrent Protection 51(N)

Operating Modes

Three-phase	Standard
Two-phase	Phases A and C

Measuring Technique

All elements	First harmonic, rms value (true rms)
--------------	--------------------------------------

Setting Ranges / Increments

Pickup current 51 (phases)	for $I_{Nom} = 1$ A	0.10 A to 4.00 A	Increments 0.01 A
	for $I_{Nom} = 5$ A	0.50 A to 20.00 A	
Pickup current 51N (ground)	for $I_{Nom} = 1$ A	0.05 A to 4.00 A	Increments 0.01 A
	for $I_{Nom} = 5$ A	0.25 A to 20.00 A	
Time multiplier T for I_p, I_{Ep} for IEC characteristics		0.05 s to 3.20 s or ∞ (disabled)	Increments 0.01 s
Time multiplier T for I_p, I_{Ep} for ANSI characteristics		0.50 s to 15.00 s or ∞ (disabled)	Increments 0.01 s

Trip Time Curves acc. to IEC

Acc. to IEC 60255-3 or BS 142, Section 3.5.2 (see also Figure 4-1 and 4-2)	
NORMAL INVERSE (Type A)	$t = \frac{0.14}{(I/I_p)^{0.02} - 1} \cdot T_p \text{ [s]}$
VERY INVERSE (Type B)	$t = \frac{13.5}{(I/I_p)^1 - 1} \cdot T_p \text{ [s]}$
EXTREMELY INV. (Type C)	$t = \frac{80}{(I/I_p)^2 - 1} \cdot T_p \text{ [s]}$
LONG INVERSE (Type B)	$t = \frac{120}{(I/I_p)^1 - 1} \cdot T_p \text{ [s]}$
For All Characteristics t trip time in seconds T_p setting value of the time multiplier I fault current I_p setting value of the pickup current	
The tripping times for $I/I_p \geq 20$ are identical with those for $I/I_p = 20$.	
For zero-sequence current read $3I_{0p}$ instead of I_p and $T_{3I_{0p}}$ instead of T_p ; for ground fault read I_{Ep} instead of I_p and T_{IEp} instead of T_p	
Pickup Threshold	approx. $1.10 \cdot I_p$

Dropout Time Characteristics with Disk Emulation acc. to IEC

Ass. to IEC 60255-3 or BS 142, Section 3.5.2 (see also Figures 4-1 and 4-2)	
INVERSE (Type A)	$t_{Reset} = \frac{9.7}{1 - (I/I_p)^2} \cdot T_p$ [s]
VERY INV. (Type B)	$t_{Reset} = \frac{43.2}{1 - (I/I_p)^2} \cdot T_p$ [s]
EXTREMELY INV. (Type C)	$t_{Reset} = \frac{58.2}{1 - (I/I_p)^2} \cdot T_p$ [s]
LONG INVERSE (Type B)	$t_{Reset} = \frac{80}{1 - (I/I_p)^2} \cdot T_p$ [s]
Where: t_{Reset} Reset Time T_p Setting Value of the Time Multiplier I Fault Current I_p Setting Value of the Pickup Current	
The dropout time curves apply to $(I/I_p) \leq 0.90$	
For zero-sequence current read $3I_0$ instead of I_p and T_{3I_0p} instead of T_p ; for ground fault read I_{Ep} instead of I_p and T_{IEp} instead of T_p	

Dropout Setting

IEC without Disk Emulation	approx. $1.05 \cdot$ setting value I_p for $I_p/I_N \geq 0.3$, this corresponds to approx. $0.95 \cdot$ pickup value
IEC with Disk Emulation	approx. $0.90 \cdot$ set value I_p

Tolerances

Pickup/dropout thresholds I_p, I_{Ep}	2% of setting value or 10 mA for $I_{Nom} = 1$ A, or 50 mA for $I_{Nom} = 5$ A
Pickup time for $2 \leq I/I_p \leq 20$	5 % of reference (calculated) value + 2 % current tolerance, respectively 30 ms
Dropout time for $I/I_p \leq 0.90$	5 % of reference (calculated) value + 2 % current tolerance, respectively 30 ms

Influencing Variables for Pickup and Dropout

Power supply direct voltage in range $0.8 \leq V_{PS}/V_{PSNom} \leq 1.15$	1 %
Temperature in range $23.00 \text{ °F } (-5 \text{ °C}) \leq \Theta_{amb} \leq 131.00 \text{ °F } (55 \text{ °C})$	0.5 %/10 K
Frequency in range $0.95 \leq f/f_{Nom} \leq 1.05$	1 %
Harmonics - up to 10 % 3rd harmonic - up to 10 % 5th harmonic	1 % 1 %
Transient overreaction during fundamental harmonic measuring procedure for $\tau > 100$ ms (with full displacement)	<5 %

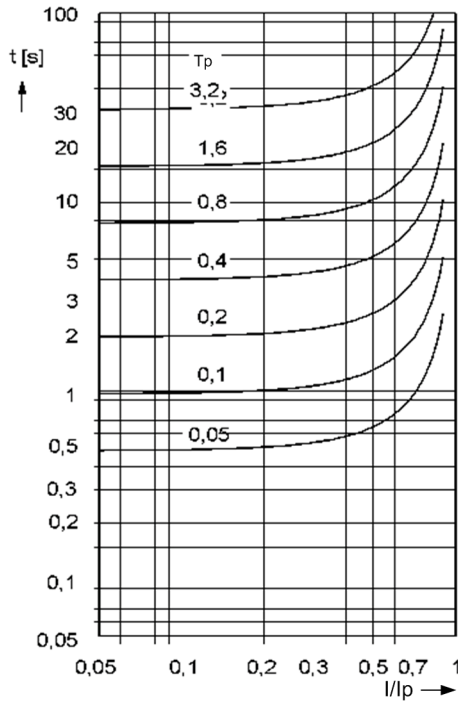

Dropout normal inverse: $t = \frac{9.7}{1 - (I/I_p)^2} \cdot T_p$ [s]
Type A

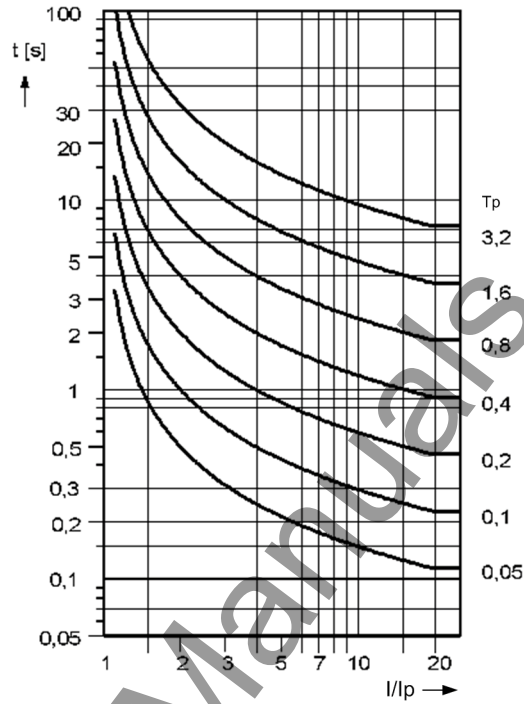

Normal Inverse: $t = \frac{0.14}{(I/I_p)^{0.02} - 1} \cdot T_p$ [s]
Type A

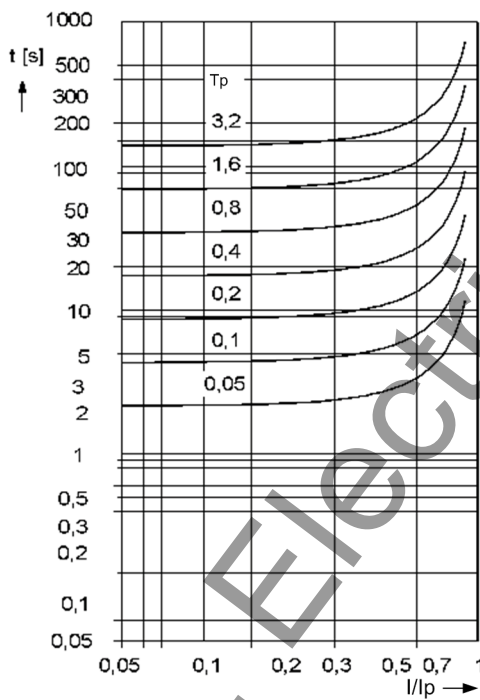

Reset Very Inverse: $t = \frac{43.2}{1 - (I/I_p)^2} \cdot T_p$ [s]
Type B

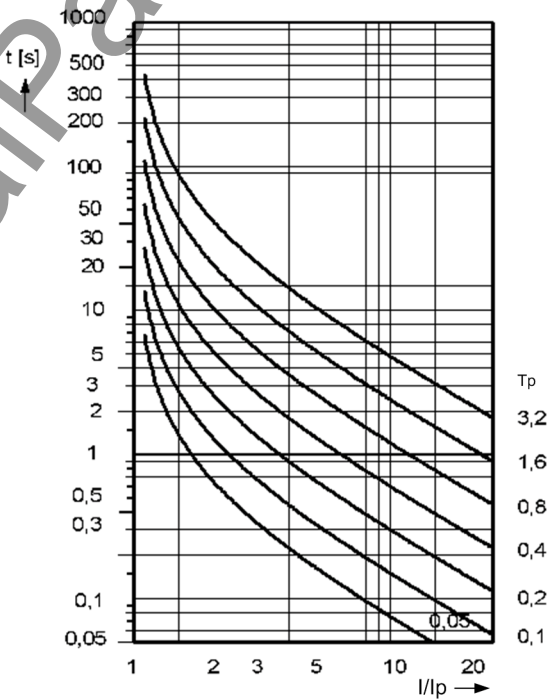

VERY INVERSE: $t = \frac{13.5}{(I/I_p)^1 - 1} \cdot T_p$ [s]
Type B

Figure 4-1 Dropout time and trip time curves of the inverse time overcurrent protection, acc. to IEC

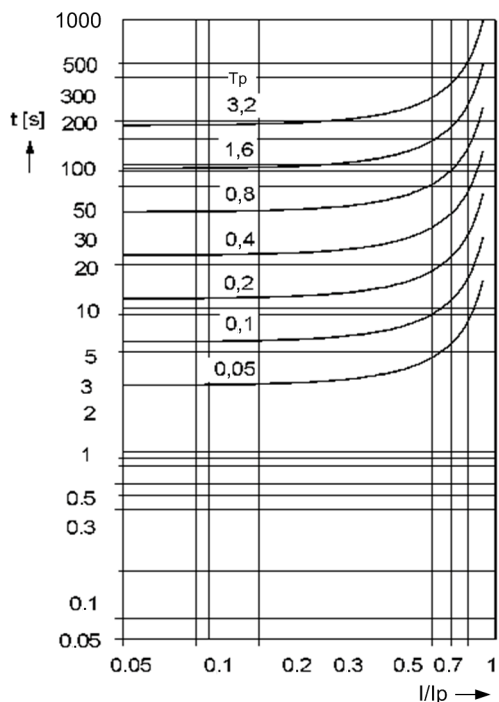

Reset Extremely Inverse:
Type C

$$t = \frac{58.2}{1 - (I/I_p)^2} \cdot T_p \text{ [s]}$$

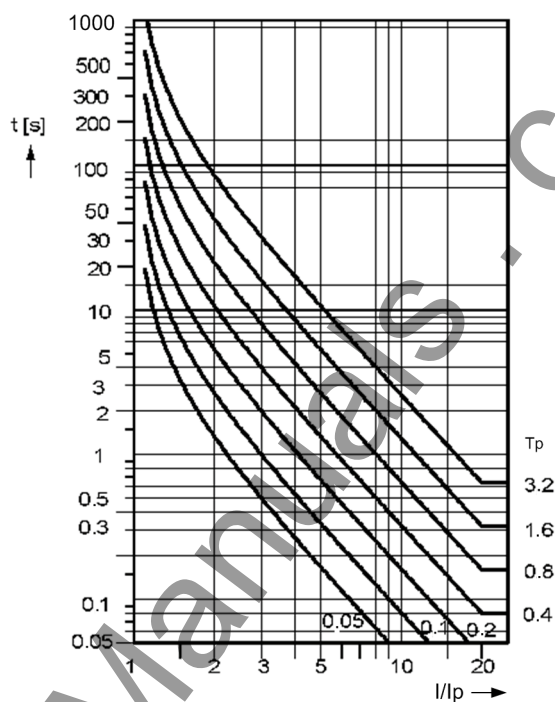

Extremely Inverse:
Type C

$$t = \frac{80}{(I/I_p)^2 - 1} \cdot T_p \text{ [s]}$$

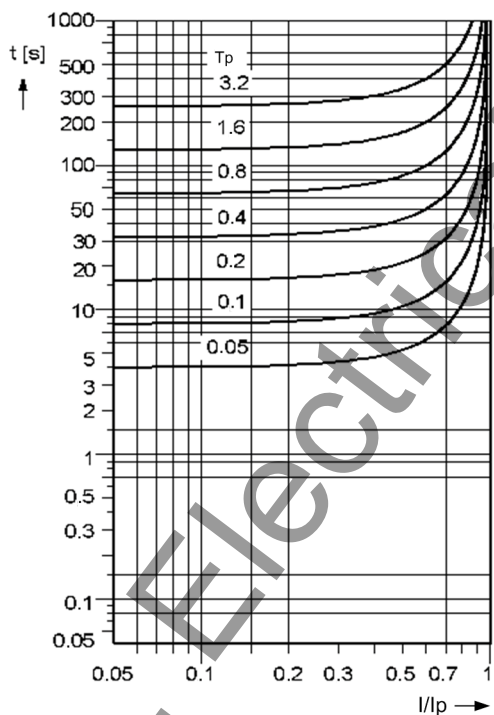

Reset long inverse:
Type B

$$t = \frac{80}{1 - (I/I_p)^2} \cdot T_p \text{ [s]}$$

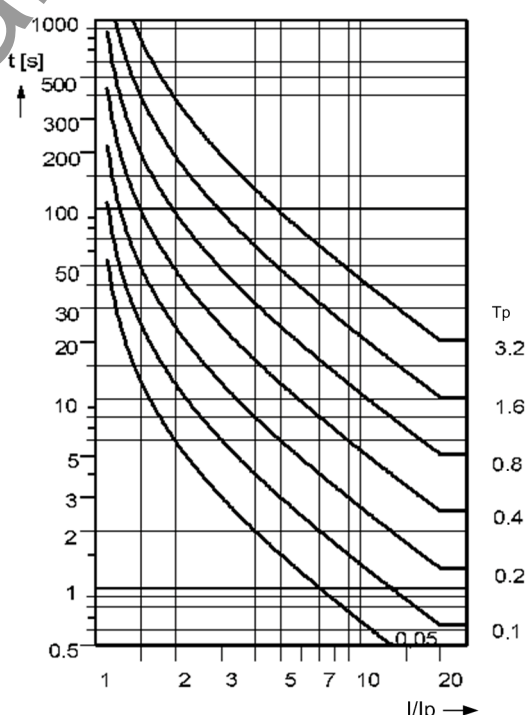

Long time Inverse:
Type B

$$t = \frac{120}{(I/I_p)^1 - 1} \cdot T_p \text{ [s]}$$

Figure 4-2 Dropout time and trip time curves of the inverse time overcurrent protection, acc. to IEC

Trip Time Curves acc. to ANSI

Acc. to ANSI/IEEE (see also Figures 4-3 to 4-6)	
INVERSE	$t = \left(\frac{8.9341}{(I/I_p)^{2.0938}} + 0.17966 \right) \cdot D \quad [s]$
SHORT INVERSE	$t = \left(\frac{0.2663}{(I/I_p)^{1.2969}} + 0.03393 \right) \cdot D \quad [s]$
LONG INVERSE	$t = \left(\frac{5.6143}{(I/I_p) - 1} + 2.18592 \right) \cdot D \quad [s]$
MODERATELY INV.	$t = \left(\frac{0.0103}{(I/I_p)^{0.02} - 1} + 0.0228 \right) \cdot D \quad [s]$
VERY INVERSE	$t = \left(\frac{3.922}{(I/I_p)^2 - 1} + 0.0982 \right) \cdot D \quad [s]$
EXTREMELY INV.	$t = \left(\frac{5.64}{(I/I_p)^2 - 1} + 0.02434 \right) \cdot D \quad [s]$
DEFINITE INV.	$t = \left(\frac{0.4797}{(I/I_p)^{1.5625} - 1} + 0.21359 \right) \cdot D \quad [s]$
Where: t Trip Time D Setting Value of the Time Multiplier I Fault Current I _p Setting Value of the Pickup Current	
The tripping times for I/I _p ≥ 20 are identical with those for I/I _p = 20.	
For zero-sequence current read 3I _{0p} instead of I _p and T _{3I_{0p}} instead of T _p ; for ground fault read I _{Ep} instead of I _p and T _{I_{Ep}} instead of T _p	
Pickup Threshold	approx. 1.10 · I _p

Dropout Time Characteristics with Disk Emulation acc. to ANSI/IEEE

Acc. to ANSI/IEEE (see also Figures 4-3 to 4-6)	
INVERSE	$t_{Reset} = \left(\frac{8.8}{1 - (I/I_p)^{2.0938}} \right) \cdot D \quad [s]$
SHORT INVERSE	$t_{Reset} = \left(\frac{0.831}{1 - (I/I_p)^{1.2969}} \right) \cdot D \quad [s]$
LONG INVERSE	$t_{Reset} = \left(\frac{12.9}{1 - (I/I_p)^1} \right) \cdot D \quad [s]$
MODERATELY INV.	$t_{Reset} = \left(\frac{0.97}{1 - (I/I_p)^2} \right) \cdot D \quad [s]$
VERY INVERSE	$t_{Reset} = \left(\frac{4.32}{1 - (I/I_p)^2} \right) \cdot D \quad [s]$
EXTREMELY INV.	$t_{Reset} = \left(\frac{5.82}{1 - (I/I_p)^2} \right) \cdot D \quad [s]$
DEFINITE INV.	$t_{Reset} = \left(\frac{1.03940}{1 - (I/I_p)^{1.5625}} \right) \cdot D \quad [s]$
Where: t_{Reset} Reset time D Setting value of the multiplier I Fault Current I_p Setting value of the pickup current	
for $0.5 < (I/I_p) \leq 0.90$	
The dropout time curves apply to $(I/I_p) \leq 0.90$	
For zero-sequence current read $3I_{0p}$ instead of I_p and $T_{3I_{0p}}$ instead of T_p ; for ground fault read I_{Ep} instead of I_p and T_{IEp} instead of T_p	

Dropout Setting

IEC without Disk Emulation	approx. $1.05 \cdot$ setting value I_p for $I_p/I_N \geq 0.3$; this corresponds to approx. $0.95 \cdot$ pickup value
ANSI with Disk Emulation	approx. $0.90 \cdot$ set value I_p

Tolerances

Pickup/dropout thresholds I_p, I_{Ep}	2% of setting value or 10 mA for $I_{Nom} = 1$ A, or 50 mA for $I_{Nom} = 5$ A
Pickup time for $2 \leq I/I_p \leq 20$	5 % of reference (calculated) value + 2 % current tolerance, respectively 30 ms
Dropout time for $I/I_p \leq 0.90$	5 % of reference (setpoint) value + 2 % or 30 ms

Influencing Variables for Pickup and Dropout

Power supply direct voltage in range $0.8 \leq V_{PS}/V_{PSNom} \leq 1.15$	1 %
Temperature in range $23.00 \text{ °F } (-5 \text{ °C}) \leq \Theta_{amb} \leq 131.00 \text{ °F } (55 \text{ °C})$	0.5 %/10 K
Frequency in range $0.95 \leq f/f_{Nom} \leq 1.05$	1 %
Harmonics - up to 10 % 3rd harmonic - up to 10 % 5th harmonic	1% 1%
Transient overreaction during fundamental harmonic measuring procedure for $\tau > 100$ ms (with full displacement)	<5 %

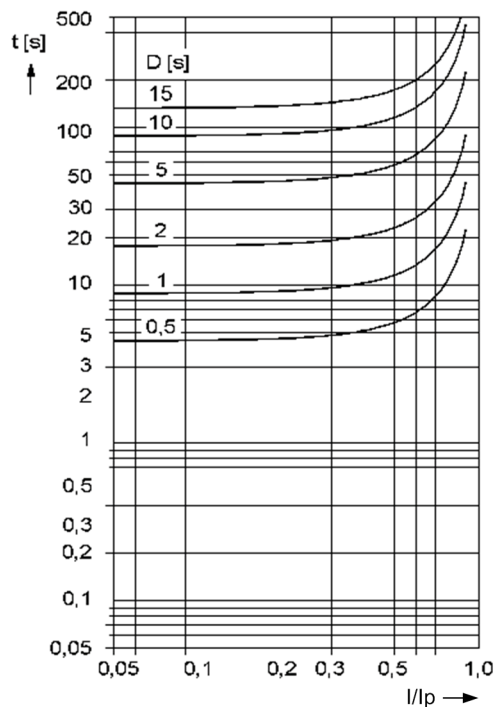

RESET INVERSE

$$t = \frac{8.8}{1 - (I/I_p)^{2.0938}} \cdot D \text{ [s]}$$

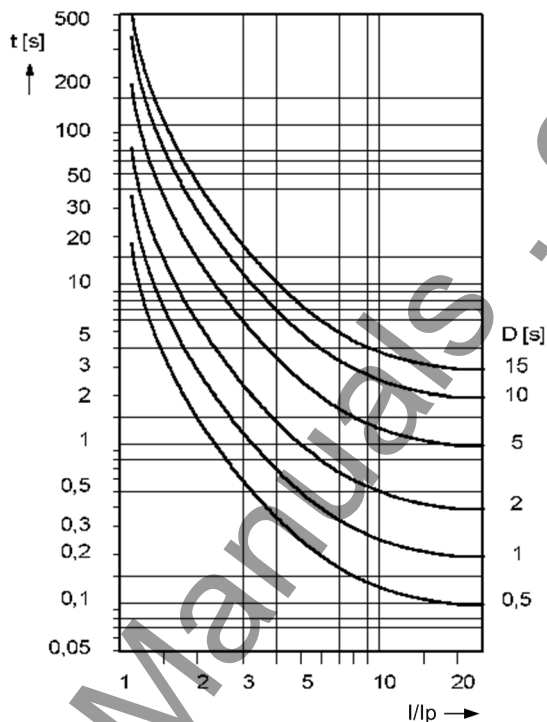

INVERSE

$$t = \left(\frac{8.9341}{(I/I_p)^{2.0938} - 1} + 0.17966 \right) \cdot D \text{ [s]}$$

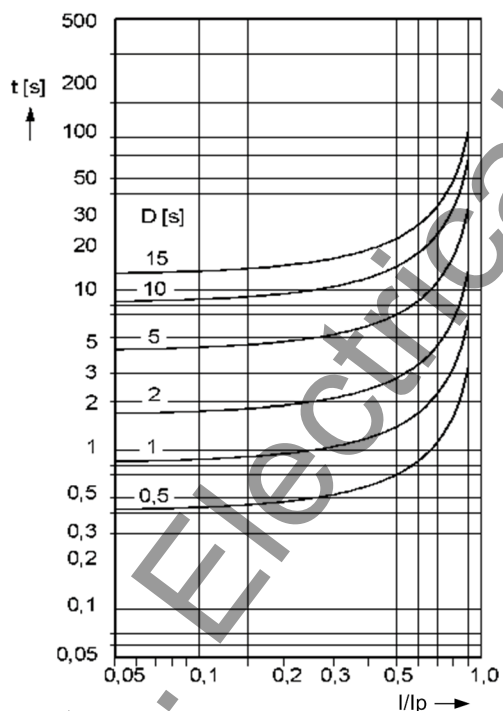

RESET SHORT INVERSE

$$t = \frac{0.831}{1 - (I/I_p)^{1.2969}} \cdot D \text{ [s]}$$

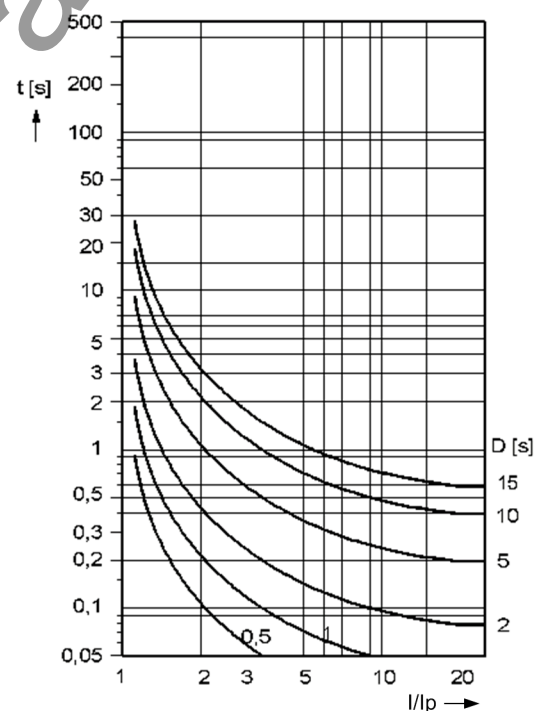

SHORT INVERSE

$$t = \left(\frac{0.2663}{(I/I_p)^{1.2969} - 1} + 0.03393 \right) \cdot D \text{ [s]}$$

Figure 4-3 Dropout time and trip time curves of the inverse time overcurrent protection, acc. to ANSI/IEEE

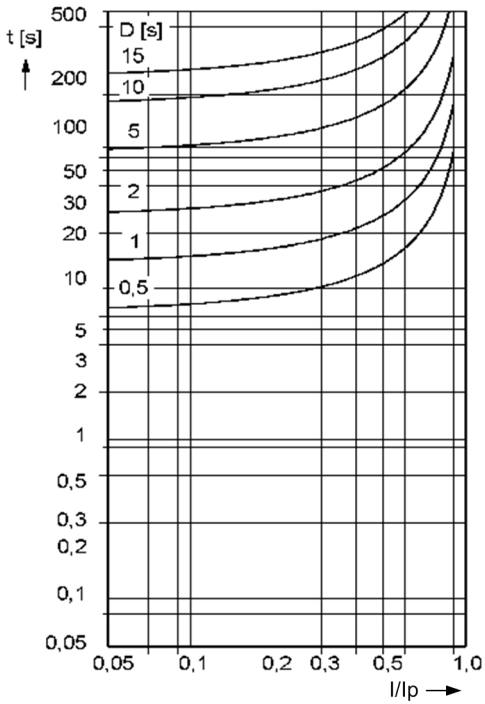

RESET LONG INVERSE $t = \left(\frac{12.9}{1 - (I/I_p)^1} \right) \cdot D \text{ [s]}$

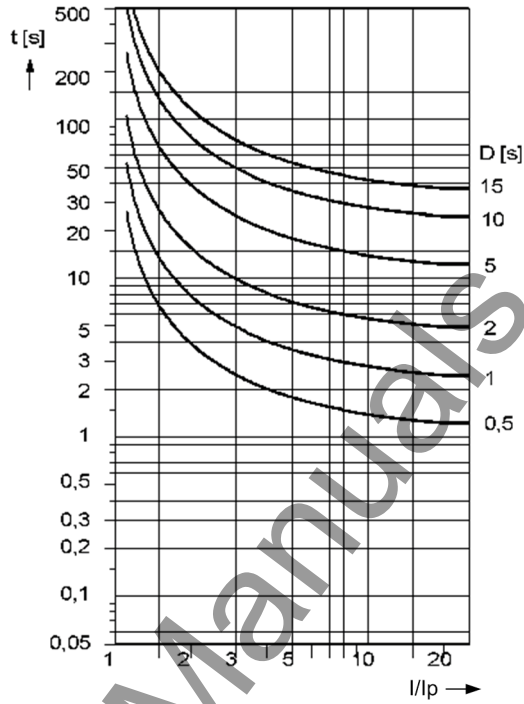

LONG INVERSE $t = \left(\frac{5.6143}{(I/I_p)^1 - 1} + 2.18592 \right) \cdot D \text{ [s]}$

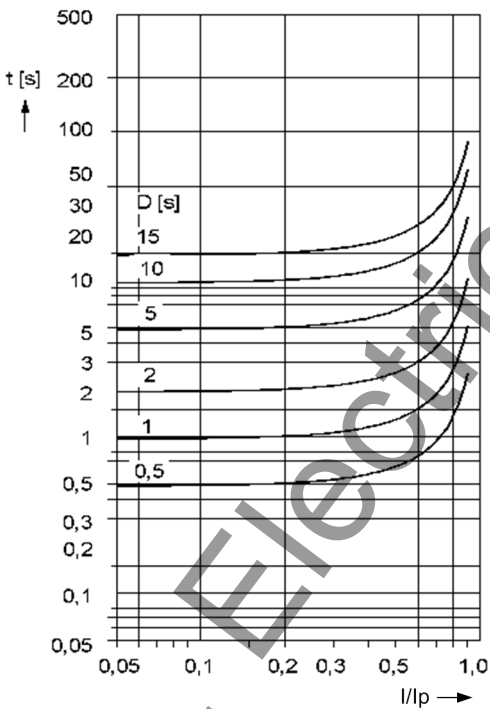

RESET MODERATELY INVERSE $t = \left(\frac{0.97}{1 - (I/I_p)^2} \right) \cdot D \text{ [s]}$

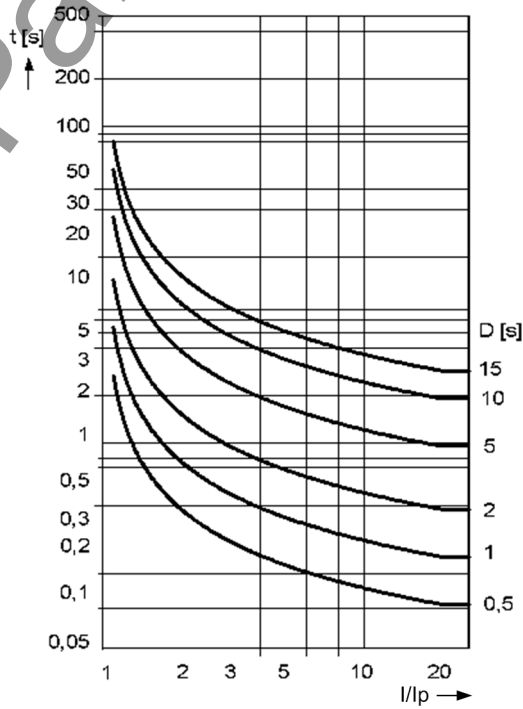

MODERATELY INVERSE $t = \left(\frac{0.0103}{(I/I_p)^{0.02} - 1} + 0.0228 \right) \cdot D \text{ [s]}$

Figure 4-4 Dropout time and trip time curves of the inverse time overcurrent protection, acc. to ANSI/IEEE

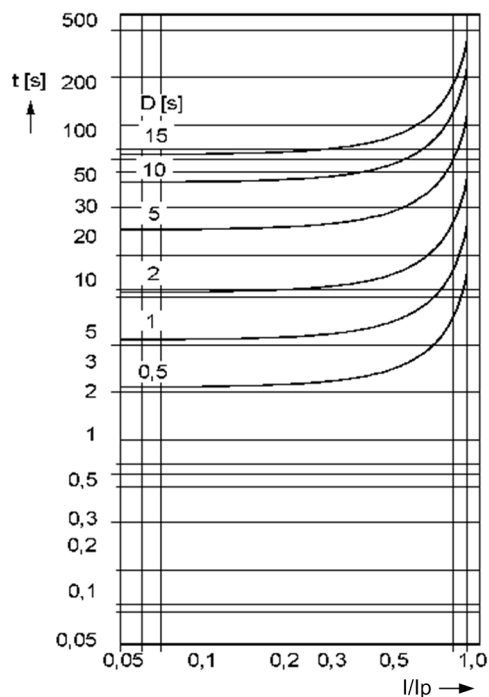

RESET VERY INVERSE $t = \left(\frac{4.32}{1 - (I/I_p)^2} \right) \cdot D \text{ [s]}$

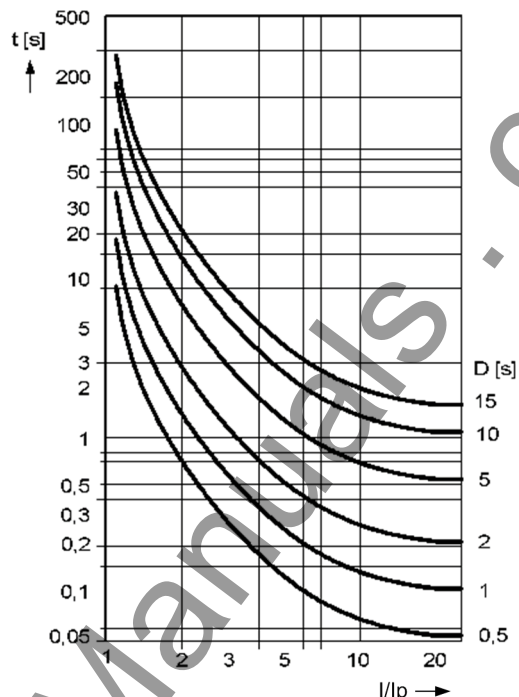

VERY INVERSE: $t = \left(\frac{3.922}{(I/I_p)^2 - 1} + 0.0982 \right) \cdot D \text{ [s]}$

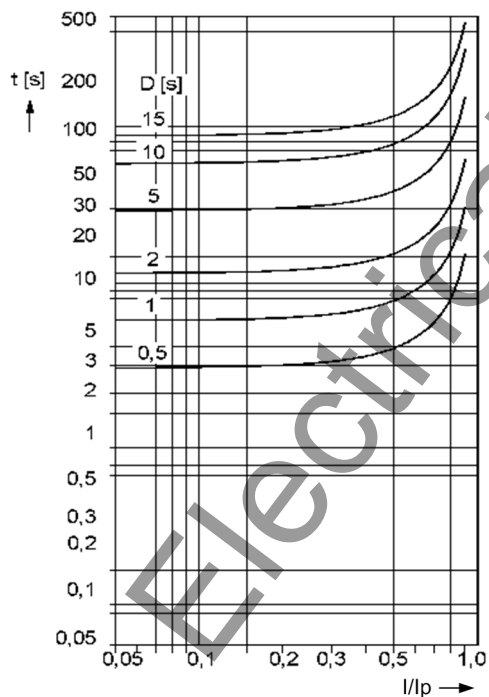

RESET EXTREMELY INVERSE $t = \left(\frac{5.82}{1 - (I/I_p)^2} \right) \cdot D \text{ [s]}$

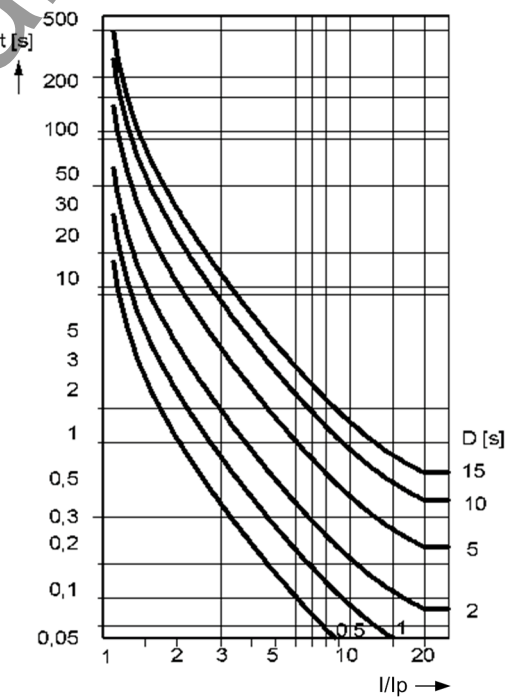

EXTREMELY INVERSE $t = \left(\frac{5.64}{(I/I_p)^2 - 1} + 0.02434 \right) \cdot D \text{ [s]}$

Figure 4-5 Dropout time and trip time curves of the inverse time overcurrent protection, acc. to ANSI/IEEE

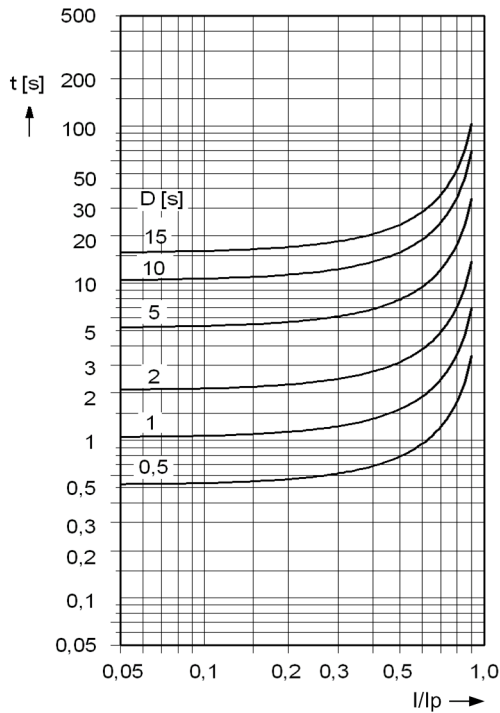

RESET DEFINITE INVERSE

$$t = \left(\frac{1.0394}{1 - (I/I_p)^{1.5625}} \right) \cdot D \text{ [s]}$$

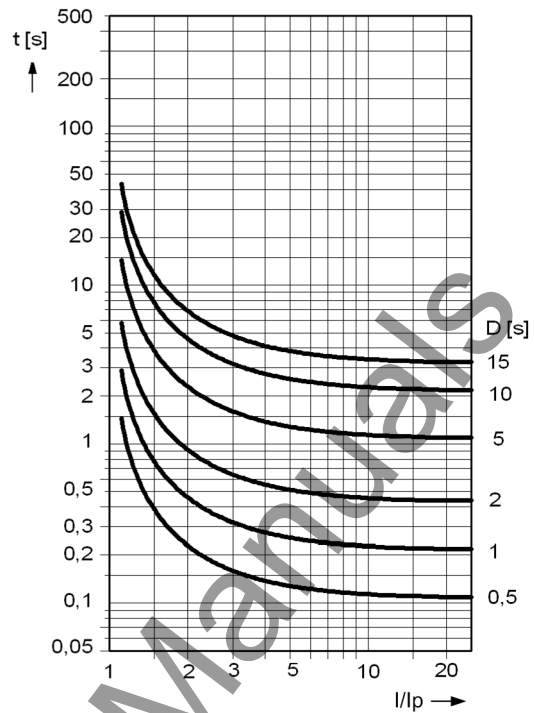

DEFINITE INVERSE

$$t = \left(\frac{0.4797}{(I/I_p)^{1.5625} - 1} + 0.21359 \right) \cdot D \text{ [s]}$$

Note:
For earth fault read IEP instead of I_p and DIEp instead of D_{Ip} .

Figure 4-6 Dropout time and trip time curve of the inverse time overcurrent protection, acc. to ANSI/IEEE

4.4 Inrush Restraint

Controlled Functions

Time Overcurrent Elements	50-1, 50N-1, 51, 51N
---------------------------	----------------------

Setting Ranges / Increments

Stabilization factor I_{2f}/I	10 % to 45 %	Increments 1 %
---------------------------------	--------------	----------------

Functional Limits

Lower Function Limit Phases	for $I_{Nom} = 1$ A	at least one phase current (50 Hz and 100 Hz) ≥ 25 mA
	for $I_{Nom} = 5$ A	at least one phase current (50 Hz and 100 Hz) ≥ 125 mA
Lower Function Limit ground	for $I_{Nom} = 1$ A	Ground current (50 Hz and 100 Hz) ≥ 25 mA
	for $I_{Nom} = 5$ A	Ground current (50 Hz and 100 Hz) ≥ 125 mA
Upper Function Limit, configurable	for $I_{Nom} = 1$ A	0.30 A to 25.00 A (increments 0.01 A)
	for $I_{Nom} = 5$ A	1.50 A to 125.00 A (increments 0.01 A)

Crossblock

Crossblock I_A, I_B, I_C	ON/OFF
----------------------------	--------

4.5 Dynamic Cold Load Pickup

Timed Changeover of Settings

Controlled Elements	Time overcurrent protection elements (separate phase and ground settings)
Initiation Criteria	Current Criterion BkrClosed I MIN
	Interrogation on the circuit breaker position
	Automatic reclosing function ready
	Binary Input
Timing	3 Time Delays ($T_{CB\ Open}$, T_{Active} , T_{Stop})
Current Control	Current threshold "BkrClosed I MIN" (reset on current falling below threshold: monitoring with timer)

Setting Ranges / Increments

Current Control „BkrClosed I MIN“	for $I_{Nom} = 1\ A$	0.04 A to 1.00 A	Increments 0.01 A
	for $I_{Nom} = 5\ A$	0.20 A to 5.00 A	
Time Until Changeover To Dynamic Settings $T_{CB\ OPEN}$		0 s to 21600 s (= 6 h)	Increments 1 s
Period Dynamic Settings are Effective After a Reclosure T_{Active}		1 s to 21600 s (= 6 h)	Increments 1 s
Fast Reset Time T_{Stop}		1 s to 600 s (= 10 min) or ∞ (fast reset inactive)	Increments 1 s
Dynamic Settings of Pickup Currents and Time Delays or Time Multipliers		Adjustable within the same ranges and with the same increments as the directional and non-directional time overcurrent protection	

4.6 Single-phase Overcurrent Protection

Current Elements

High-set current elements	50-2	0.05 A to 35.00 A ¹⁾ 0.003 A to 1.500 A ²⁾ or ∞ (element disabled)	Increments 0.01 A Increments 0.001 A
	T ₅₀₋₂	0.00 s to 60.00 s or ∞ (no trip)	Increments 0.01 s
Definite-Time Current Element	50-1	0.05 A to 35.00 A ¹⁾ 0.003 A to 1.500 A ²⁾ or ∞ (element disabled)	Increments 0.01 A Increments 0.001 A
	T ₅₀₋₁	0.00 s to 60.00 s or ∞ (no trip)	Increments 0.01 s
<p>The set times are pure delay times. ¹⁾ Secondary values for I_{Nom} = 1 A; with I_{Nom} = 5 A multiply currents by 5 ²⁾ Secondary values for „sensitive“ measuring input, independent of nominal device current</p>			

Operating Times

Pickup/Dropout Times		
Frequency Pickup Time	50 Hz	60 Hz
minimum	14 ms	13 ms
maximum	≤ 35 ms	≤ 35 ms
Dropout time approx.	25 ms	22 ms

Dropout Ratios

Current Elements	approx. 0.95 for I/I _{Nom} ≥ 0.5
------------------	---

Tolerances

Currents	3 % of setting value or 1 % of nominal current at I _{Nom} = 1 A or 5 A 5 % of setting value or 3 % of nominal current at I _{Nom} = 0.1 A
Times	1 % of setting value or 10 ms

Influencing Variables for Pickup Values

Power supply direct voltage in range $0.8 \leq V_{PS}/V_{PSNom} \leq 1.15$	1 %
Temperature in range 23.00 °F (-5 °C) ≤ Θ_{amb} ≤ 131.00 °F (55 °C)	0.5 %/10 K
Frequency in range $0.95 \leq f/f_{Nom} \leq 1.05$	1 %
Harmonics	
- up to 10 % 3rd harmonic	1 %
- up to 10 % 5th harmonic	1 %

4.7 Negative Sequence Protection 46-1, 46-2

Setting Ranges / Increments

Unbalanced load tripping element 46-1,46-2	for $I_{Nom} = 1 \text{ A}$	0.10 A to 3.00 A or ∞ (disabled)	Increments 0.01 A
	for $I_{Nom} = 5 \text{ A}$	0.50 A to 15.00 A or ∞ (disabled)	
Delay Times 46-1, 46-2		0.00 s to 60.00 s or ∞ (disabled)	Increments 0.01 s
Dropout Delay Times 46 T DROP-OUT		0.00 s to 60.00 s	Increments 0.01 s

Functional Limit

Functional Limit	for $I_{Nom} = 1 \text{ A}$	all phase currents $\leq 10 \text{ A}$
	for $I_{Nom} = 5 \text{ A}$	all phase currents $\leq 50 \text{ A}$

Times

Pickup Times	Approx. 35 ms
Dropout Times	Approx. 35 ms

Dropout Ratio

Characteristic 46-1, 46-2	Approx. 0.95 for $I_2/I_{Nom} \geq 0.3$
---------------------------	---

Tolerances

Pickup values 46-1, 46-2	3 % of set value or 10 mA for $I_{Nom} = 1 \text{ A}$ or 50 mA for $I_{Nom} = 5 \text{ A}$
Time Delays	1 % or 10 ms

Influencing Variables for Pickup Values

Power supply direct voltage in range $0.8 \leq V_{PS}/V_{PSNom} \leq 1.15$	1 %
Temperature in range $23.00 \text{ }^\circ\text{F} (-5 \text{ }^\circ\text{C}) \leq \Theta_{amb} \leq 131.00 \text{ }^\circ\text{F} (55 \text{ }^\circ\text{C})$	0.5 %/10 K
Frequency in range $0.95 \leq f/f_{Nom} \leq 1.05$	1 %
Harmonics	
- up to 10 % 3rd harmonic	1 %
- up to 10 % 5th harmonic	1 %
Transient overreaction for $\tau > 100 \text{ ms}$ (with full displacement)	<5 %

4.8 Negative Sequence Protection 46-TOC

Setting Ranges / Increments

Pickup value 46-TOC (I_{2p})	for $I_{Nom} = 1$ A	0.10 A to 2.00 A	Increments 0.01 A
	for $I_{Nom} = 5$ A	0.50 A to 10.00 A	
Time Multiplier T_{I2p} (IEC)		0.05 s to 3.20 s or ∞ (disabled)	Increments 0.01 s
Time Multiplier D_{I2p} (ANSI)		0.50 s to 15.00 s or ∞ (disabled)	Increments 0.01 s

Functional Limit

Functional Limit	for $I_{Nom} = 1$ A	all phase currents ≤ 10 A
	for $I_{Nom} = 5$ A	all phase currents ≤ 50 A

Trip Time Curves acc. to IEC

See also Figure 4-7	
INVERSE	$t_{TRIP} = \frac{0.14}{(I_2/I_{2p})^{0.02} - 1} \cdot T_{I2p} \quad [s]$
VERY INVERSE	$t_{TRIP} = \frac{13.5}{(I_2/I_{2p})^1 - 1} \cdot T_{I2p} \quad [s]$
EXTREMELY INV.	$t_{TRIP} = \frac{80}{(I_2/I_{2p})^2 - 1} \cdot T_{I2p} \quad [s]$
Where: t_{TRIP} Trip Time T_{I2p} Setting Value of the Time Multiplier I_2 Negative Sequence Current I_{2p} Setting Value of the Pickup Current	
The trip times for $I_2/I_{2p} \geq 20$ are identical to those for $I_2/I_{2p} = 20$.	
Pickup Threshold	Approx. $1.10 \cdot I_{2p}$

Trip Time Curves acc. to ANSI

It can be selected one of the represented trip time characteristic curves in the figures 4-8 and 4-9 each on the right side of the figure.

INVERSE	$t_{TRIP} = \left(\frac{8.9341}{(I_2/I_{2p})^{2.0938} - 1} + 0.17966 \right) \cdot D_{I2p} \quad [s]$
MODERATELY INVERSE	$t_{TRIP} = \left(\frac{0.0103}{(I_2/I_{2p})^{0.02} - 1} + 0.0228 \right) \cdot D_{I2p} \quad [s]$
VERY INVERSE	$t_{TRIP} = \left(\frac{3.922}{(I_2/I_{2p})^2 - 1} + 0.0982 \right) \cdot D_{I2p} \quad [s]$
EXTREMELY INV.	$t_{TRIP} = \left(\frac{5.64}{(I_2/I_{2p})^2 - 1} + 0.02434 \right) \cdot D_{I2p} \quad [s]$

Where:
 t_{TRIP} Trip Time
 D_{I2p} Setting Value of the Time Multiplier
 I_2 Negative Sequence Currents
 I_{2p} Setting Value of the Pickup Current

The trip times for $I_2/I_{2p} \geq 20$ are identical to those for $I_2/I_{2p} = 20$.

Pickup Threshold	Approx. $1.10 \cdot I_{2p}$
------------------	-----------------------------

Tolerances

Pickup Threshold I_{2p}	3 % of setting value or 10 mA for $I_{Nom} = 1$ A or 50 mA with $I_{Nom} = 5$ A
Time for $2 \leq I/I_{2p} \leq 20$	5 % of reference (calculated) value + 2 % current tolerance, respectively 30 ms

Dropout Time Curves with Disk Emulation acc. to ANSI

Representation of the possible dropout time curves, see figure 4-8 and 4-9 each on the left side of the figure

INVERSE	$t_{Reset} = \left(\frac{8.8}{1 - (I_2/I_{2p})^{2.0938}} \right) \cdot D_{I2p} \quad [s]$
MODERATELY INV.	$t_{Reset} = \left(\frac{0.97}{1 - (I_2/I_{2p})^2} \right) \cdot D_{I2p} \quad [s]$
VERY INVERSE	$t_{Reset} = \left(\frac{4.32}{1 - (I_2/I_{2p})^2} \right) \cdot D_{I2p} \quad [s]$
EXTREMELY INV.	$t_{Reset} = \left(\frac{5.82}{1 - (I_2/I_{2p})^2} \right) \cdot D_{I2p} \quad [s]$

Where:
 t_{Reset} Reset Time
 D_{I2p} Setting Value of the Time Multiplier
 I_2 Negative Sequence Current
 I_{2p} Setting Value of the Pickup Current

The dropout time constants apply to $(I_2/I_{2p}) \leq 0.90$

Dropout Value

IEC and ANSI (without Disk Emulation)	Approx. $1.05 \cdot I_{2p}$ setting value, which is approx. $0.95 \cdot$ pickup threshold I_2
ANSI with Disk Emulation	Approx. $0.90 \cdot I_{2p}$ setting value

Tolerances

Pickup threshold I_{2p}	2 % of set value or 10 mA for $I_{Nom} = 1$ A or 50 mA for $I_{Nom} = 5$ A
Time for $I_2/I_{2p} \leq 0.90$	5 % of reference (calculated) value + 2 % current tolerance, respectively 30 ms

Influencing Variables for Pickup Values

Power supply direct voltage in range $0.8 \leq V_{PS}/V_{PSNom} \leq 1.15$	1 %
Temperature in range $23.00 \text{ °F } (-5 \text{ °C}) \leq \Theta_{amb} \leq 131.00 \text{ °F } (55 \text{ °C})$	0.5 %/10 K
Frequency in range $0.95 \leq f/f_{Nom} \leq 1.05$	1 %
Harmonics - up to 10 % 3rd harmonic - up to 10 % 5th harmonic	1 % 1 %
Transient overreaction for $\tau > 100$ ms (with full displacement)	<5 %

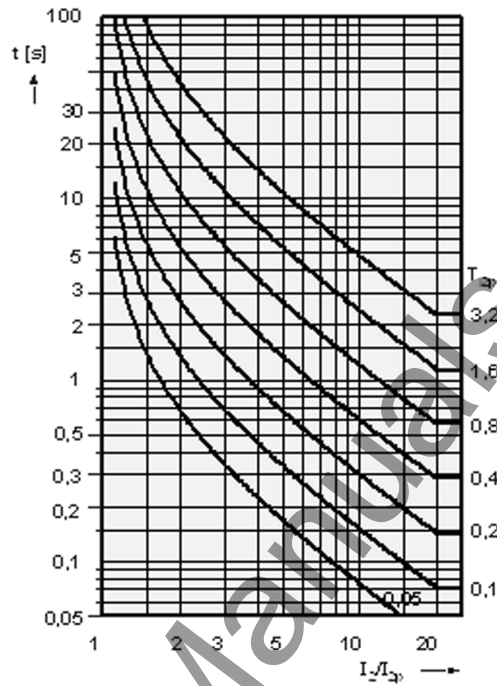
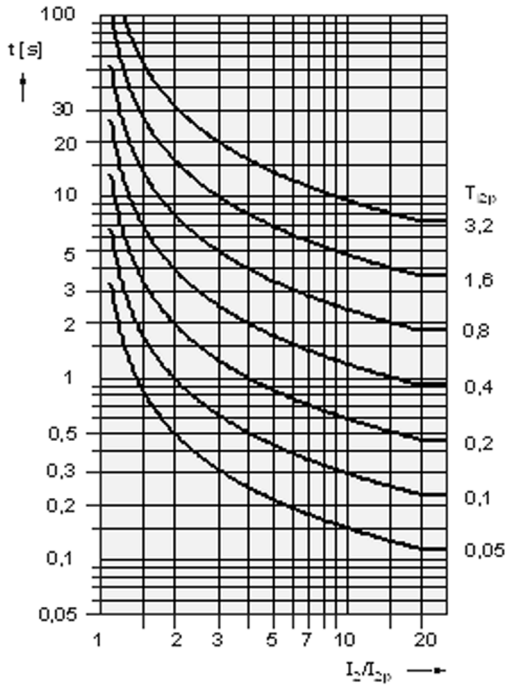

IEC INVERSE:
$$t = \frac{0.14}{(I_2/I_{2p})^{0.02} - 1} \cdot T_{I2p} \text{ [s]}$$

IEC VERY INVERSE:
$$t = \frac{13.5}{(I_2/I_{2p})^1 - 1} \cdot T_{I2p} \text{ [s]}$$

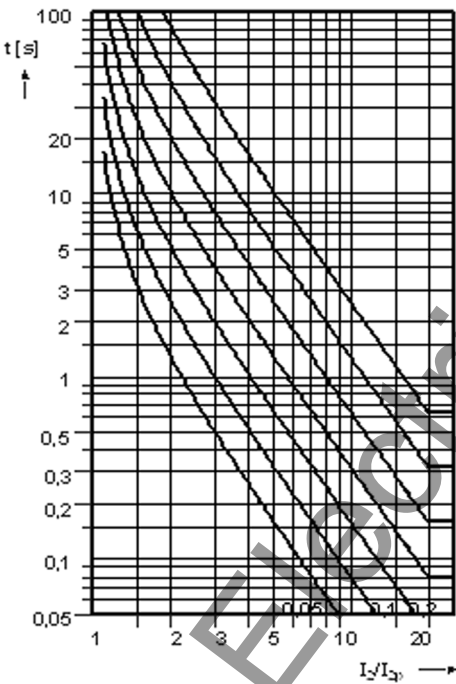

IEC EXTREMELY INVERSE:
$$t = \frac{80}{(I_2/I_{2p})^2 - 1} \cdot T_{I2p} \text{ [s]}$$

- t Tripping Time
- T_{I2p} Setting Value of the Time Factor
- I_2 Inverse current
- I_{2p} Pickup current of unbalanced load protection

Figure 4-7 Trip time characteristics of the inverse time negative sequence element 46-TOC, acc. to IEC

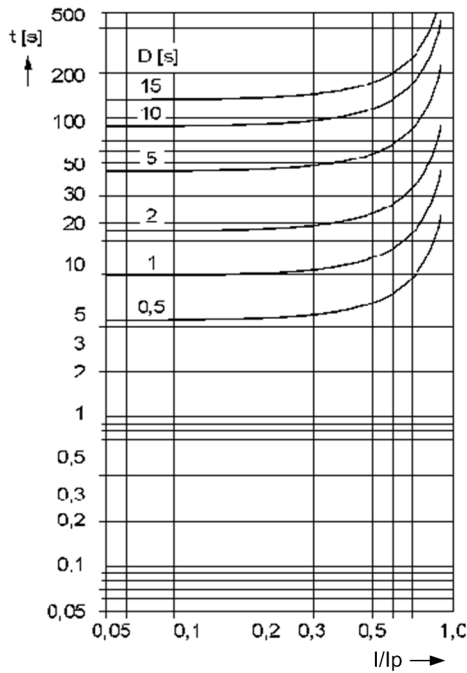

RESET INVERSE

$$t = \left(\frac{8.8}{1 - (I_2/I_{2p})^{2.0938}} \right) \cdot D \text{ [s]}$$

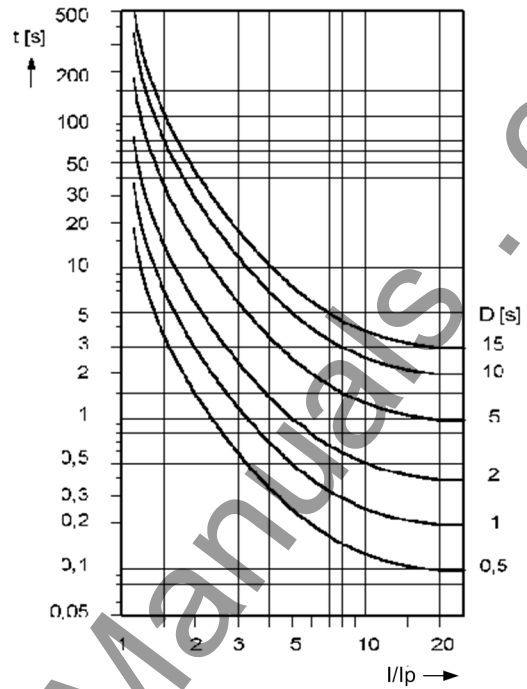

INVERSE

$$t = \left(\frac{8.9341}{(I_2/I_{2p})^{2.0938} - 1} + 0.17966 \right) \cdot D \text{ [s]}$$

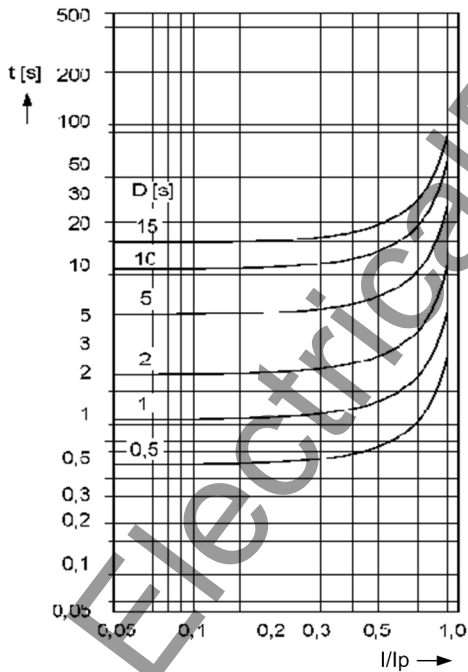

RESET MODERATELY
INVERSE

$$t = \left(\frac{0.97}{1 - (I_2/I_{2p})^2} \right) \cdot D \text{ [s]}$$

MODERATELY INVERSE

$$t = \left(\frac{0.0103}{(I_2/I_{2p})^{0.02} - 1} + 0.0228 \right) \cdot D \text{ [s]}$$

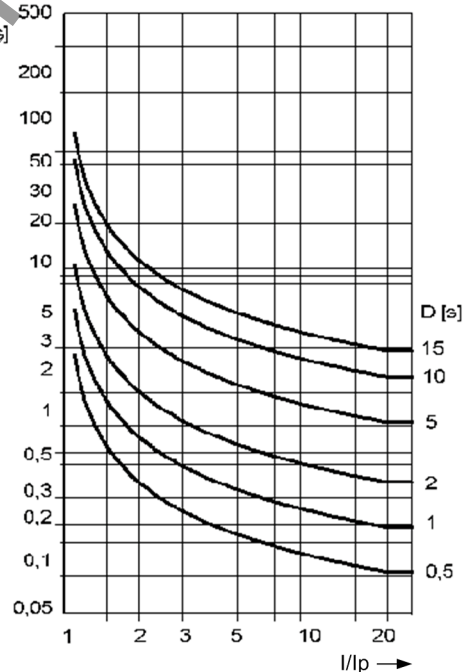
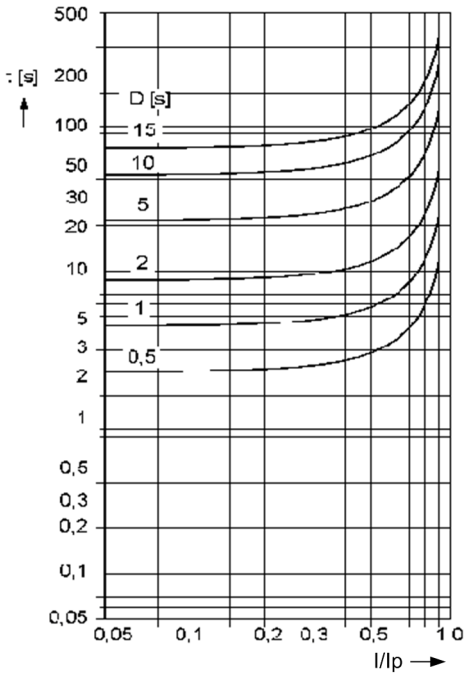
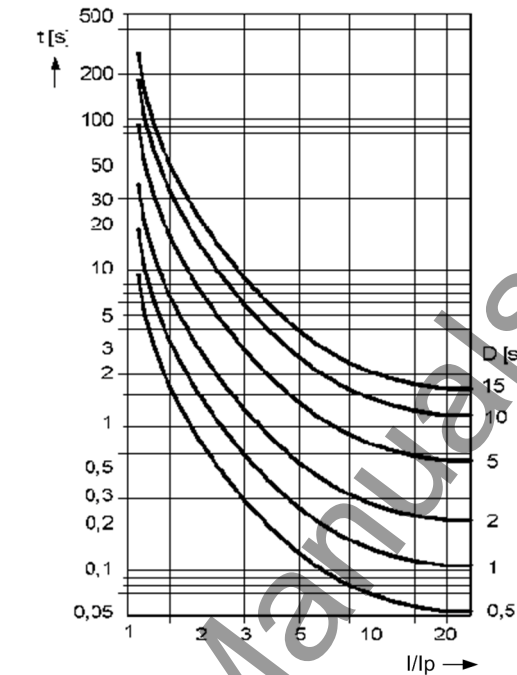

Figure 4-8 Dropout time and trip time characteristics of the inverse time unbalanced load stage, acc. to ANSI



RESET VERY INVERSE

$$t = \left(\frac{4.32}{1 - (I_2/I_{2p})^2} \right) \cdot D \text{ [s]}$$



VERY INVERSE:

$$t = \left(\frac{3.922}{(I_2/I_{2p})^2 - 1} + 0.0982 \right) \cdot D \text{ [s]}$$

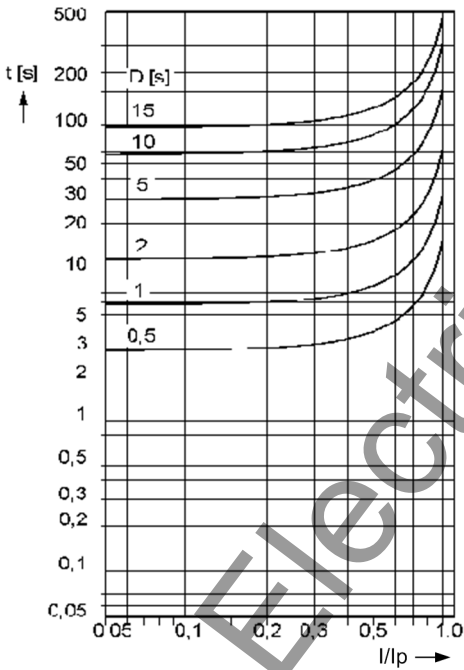

RESET EXTREMELY INVERSE

$$t = \left(\frac{5.82}{1 - (I_2/I_{2p})^2} \right) \cdot D \text{ [s]}$$

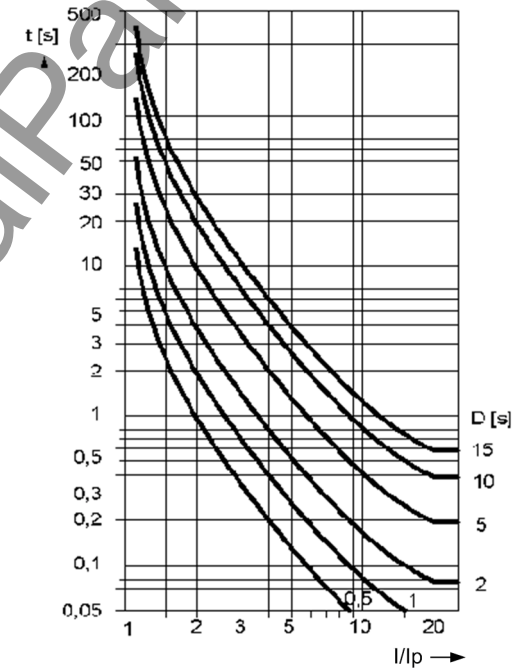

EXTREMELY INVERSE

$$t = \left(\frac{5.64}{(I_2/I_{2p})^2 - 1} + 0.02434 \right) \cdot D \text{ [s]}$$

Figure 4-9 Dropout time and trip time characteristics of the inverse time unbalanced load stage, acc. to ANSI

4.9 Motor Starting Protection 48

Setting Ranges / Increments

Startup current of the motor $I_{STARTUP}$	for $I_{Nom} = 1\text{ A}$	0.50 A to 16.00 A	Increment 0.01 A
	for $I_{Nom} = 5\text{ A}$	2.50 A to 80.00 A	
Pickup threshold $I_{MOTOR\ START}$	for $I_{Nom} = 1\text{ A}$	0.40 A to 10.0 A	Increment 0.01 A
	for $I_{Nom} = 5\text{ A}$	2.00 A to 50.00 A	
Permissible startup time $T_{Max.STARTUP}$		1.0 s to 180.0 s	Increments 0.1 s
Permissible locked rotor time $T_{LOCKED\ ROTOR}$		0.5 s to 120.0 s or ∞ (disabled)	Increments 0.1 s
Maximum startup time with warm motor $T_{Max.STARTUP\ W}$		0.5 s to 180.0 s or ∞ (disabled)	Increments 0.1 s
Maximum startup time with cold motor $T_{Max.STARTUP\ C}$		0 % to 80 % or ∞ (disabled)	Increments 1 %

Trip Curve

Trip time characteristics for $I > I_{MOTOR\ START}$	$t_{TRIP} = \left(\frac{I_{STARTUP}}{I_{rms}} \right)^2 \cdot T_{Max.STARTUP}$
Where:	$I_{STARTUP}$: Motor starting current setting. I : Actual current flowing. $I_{MOTOR\ START}$: Pickup threshold setting, used to detect motor startup. t_{TRIP} : Trip time in seconds. $T_{Max.STARTUP}$: Tripping time for nominal startup current

Dropout Ratio

Dropout ratio	Approx. 0.95
---------------	--------------

Tolerances

Pickup Threshold	2 % of set value or 10 mA for $I_{Nom} = 1\text{ A}$ or 50 mA for $I_{Nom} = 5\text{ A}$
Time Delay	5 % or 30 ms

Influencing Variables

Power supply direct voltage in range $0.8 \leq V_{PS}/V_{PSNom} \leq 1.15$	1 %
Temperature in range $23.00\text{ °F} (-5\text{ °C}) \leq \theta_{amb} \leq 131.00\text{ °F} (55\text{ °C})$	0.5 %/10 K
Frequency in range $f_{Nom} \pm 5\text{ Hz}$	1 %
Harmonics	
- up to 10 % 3rd harmonic	1 %
- up to 10 % 5th harmonic	1 %

4.10 Motor Restart Inhibit 66

Setting Ranges / Increments

Motor starting current relative to nominal motor current $I_{Start}/I_{Motor\ Nom.}$	1.1 to 10.0	Increment 0.1
Nominal motor current $I_{Motor\ Nom.}$	for $I_{Nom} = 1\ A$	0.20 A to 1.20 A
	for $I_{Nom} = 5\ A$	1.00 A to 6.00 A
Max. permissible starting time $T_{START\ max.}$	3 s to 320 s	Increments 1 s
Equilibrium time T_{Equal}	0.0 min to 320.0 min	Increments 0.1 min
Minimum inhibit time $T_{MIN.\ INHIBIT\ TIME}$	0.2 min to 120.0 min	Increments 0.1 min
Maximum permissible number of warm startups n_{WARM}	1 to 4	Increment 1
Difference between cold and warm startups $n_{COLD} - n_{WARM}$	1 to 2	Increment 1
Extension of Time Constant at stop $k_{\tau\ at\ STOP}$	0.2 to 100.0	Increment 0.1
Extension of Time constant at running $k_{\tau\ at\ RUNNING}$	0.2 to 100.0	Increment 0.1

Restart Threshold

$\Theta_{Restart} = \left(\frac{I_{STARTUP}}{I_{MOTNom} \cdot k_R} \right)^2 \cdot \left(1 - e^{-\frac{(n_{cold} - 1) \cdot T_{start\ max}}{\tau_R}} \right)$	
Where:	$\Theta_{RESTART}$ = Temperature limit below which restarting is possible k_R = k-factor for the rotor $I_{STARTUP}$ = Startup current I_{MotNom} = Motor nominal current $T_{start\ max}$ = Max. startup time τ_R = Thermal rotor time constant n_{cold} = Max. number of cold starts

Influencing Variables

Power supply direct voltage in range $0.8 \leq V_{PS}/V_{PSNom} \leq 1.15$	1 %
Temperature in range $23.00\ ^\circ F (-5\ ^\circ C) \leq \Theta_{amb} \leq 131.00\ ^\circ F (55\ ^\circ C)$	0.5 %/10 K
Frequency in range $f_{Nom} \pm 5\ Hz$	1 %
Frequency outside range $f_{Nom} \pm 5\ Hz$	Increased Tolerances

4.11 Load Jam Protection

Setting Ranges / Increments

Tripping threshold	for $I_{Nom} = 1 \text{ A}$	0.50 A to 12.00 A	Increments 0.01 A
	for $I_{Nom} = 5 \text{ A}$	2.50 A to 60.00 A	
Alarm threshold	for $I_{Nom} = 1 \text{ A}$	0.50 A to 12.00 A	Increments 0.01 A
	for $I_{Nom} = 5 \text{ A}$	2.50 A to 60.00 A	
Trip delay		0.00 s to 600.00 s	Increments 0.01 s
Message delay		0.00 s to 600.00 s	Increments 0.01 s
Blocking duration after motor start		0.00 s to 600.00 s	Increments 0.01 s

Timers

Pickup time	approx. 55 ms
Dropout time	approx. 30 ms

Dropout ratio

Dropout ratio tripping stage	approx. 0.95
Dropout ratio warning stage	approx. 0.95

Tolerances

Pickup threshold	for $I_{Nom} = 1 \text{ A}$	2 % of setting value or 10 mA
	for $I_{Nom} = 5 \text{ A}$	2 % of setting value or 50 mA
Time delay		1 % or 10 ms

Influencing Variables

Power supply direct voltage in range $0.8 \leq V_{PS}/V_{PSNom} \leq 1.15$	1 %
Temperature in range $23.00 \text{ °F} (-5 \text{ °C}) \leq \theta_{amb} \leq 131.00 \text{ °F} (55 \text{ °C})$	0.5 %/10 K
Frequency in range $f_{Nom} \pm 5 \text{ Hz}$	1 %
Harmonics	
- up to 10 % 3rd harmonic	1 %
- up to 10 % 5th harmonic	1 %

4.12 Thermal Overload Protection 49

Setting Ranges / Increments

K-Factor per IEC 60255-8	0.10 to 4.00	Increments 0.01
Time Constant τ_{th}	1.0 min to 999.9 min	Increments 0.1 min
Thermal Alarm $\Theta_{Alarm}/\Theta_{Trip}$	50% to 100% of the trip excessive temperature	Increments 1 %
Current Overload I_{Alarm}	for $I_{Nom} = 1 A$	0.10 A to 4.00 A
	for $I_{Nom} = 5 A$	0.50 A to 20.00 A
Extension $k\tau$ Factor when Machine Stopped	1.0 to 10.0 relative to the time constant for the machine running	Increments 0.1
Emergency Time $T_{Emergency}$	10 s to 15000 s	Increments 1 s
Nominal Overtemperature (for I_{Nom})	40 °C to 200 °C = -13 °F to +185 °F	Increments 1 °C

Trip Characteristic

<p>Trip Characteristic Curve for $(I/k \cdot I_{Nom}) \leq 8$</p> $t = \tau_{th} \cdot \ln \frac{\left(\frac{I}{k \cdot I_{Nom}}\right)^2 - \left(\frac{I_{pre}}{k \cdot I_{Nom}}\right)}{\left(\frac{I}{k \cdot I_{Nom}}\right)^2 - 1}$ <p>Where:</p> <ul style="list-style-type: none"> t Trip Time in minutes τ_{th} Heating-up Time Constant I Actual Load Current I_{pre} Preload Current k Setting Factor per IEC 60255-8 I_{Nom} Nominal Current of the Protected Object
--

Dropout Ratios

Θ/Θ_{Trip}	Drops out with Θ_{Alarm}
Θ/Θ_{Alarm}	Approx. 0.99
I/I_{Alarm}	Approx. 0.97

Tolerances

Referring to $k \cdot I_{Nom}$	2 % or 10 mA for $I_{Nom} = 1 A$, or 50 mA for $I_{Nom} = 5 A$, 2 % class according to IEC 60255-8
Referring to Trip Time	3 % or 1 s for $I/(k \cdot I_{Nom}) > 1.25$; 3 % class according to IEC 60255-8

Influencing Variables Referring to $k \cdot I_{Nom}$

Power supply direct voltage in range $0.8 \leq V_{PS}/V_{PSNom} \leq 1.15$	1 %
Temperature in range of $23.00 \text{ °F } (-5 \text{ °C}) \leq \Theta_{amb} \leq 131.00 \text{ °F } (55 \text{ °C})$	0.5 %/10 K
Frequency in range $f_N \pm 5 \text{ Hz}$	1 %
Frequency out of Range $f_{Nom} \pm 5 \text{ Hz}$	Increased Tolerances

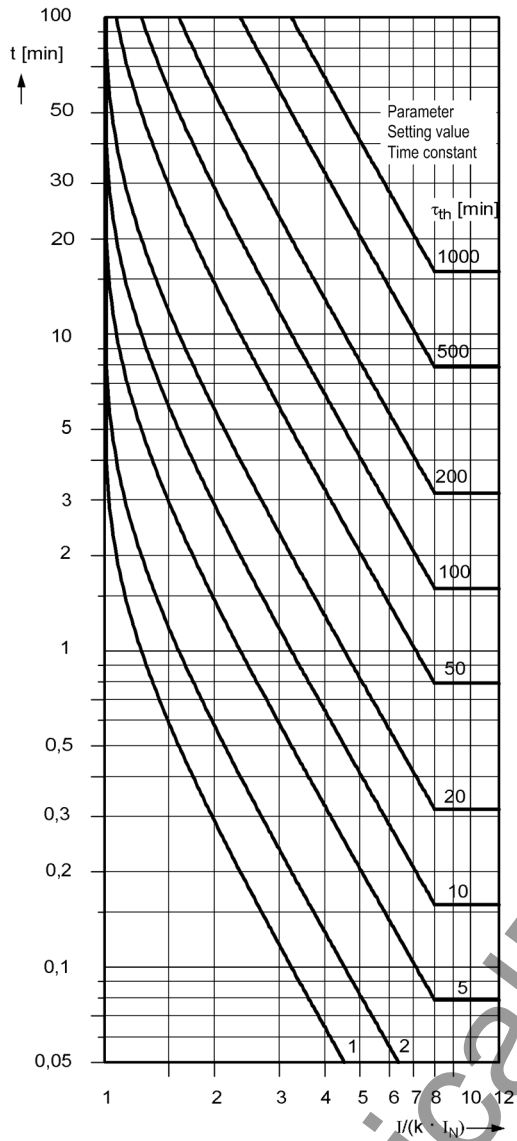

without pre-load:

$$t = \tau_{th} \cdot \ln \frac{\left(\frac{I}{k \cdot I_N}\right)^2}{\left(\frac{I}{k \cdot I_N}\right)^2 - 1} \text{ [min]}$$

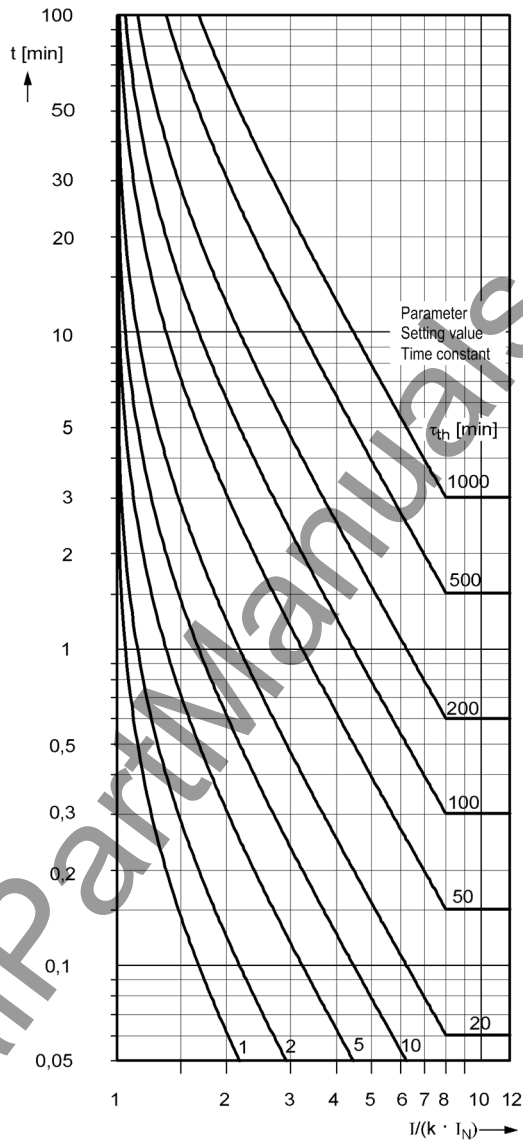

with 90 % pre-load:

$$t = \tau_{th} \cdot \ln \frac{\left(\frac{I}{k \cdot I_N}\right)^2 - \left(\frac{\Theta}{\Theta_{OFF}}\right)}{\left(\frac{I}{k \cdot I_N}\right)^2 - 1} \text{ [min]}$$

Figure 4-10 Trip time curves for the thermal overload protection (49)

4.13 Ground Fault Protection 50N(s), 51N(s)

Ground Fault Pickup for All Types of Ground Faults (Definite Time Curve)

Pickup current 50Ns-2 for sensitive transformer for normal 1-A transformer for normal 5-A transformer	0.001 A to 1.500 A 0.05 A to 35.00 A 0.25 A to 175.00 A	Increments 0.001 A Increments 0.01 A Increments 0.05 A
Delay Time T_{50N-2}	0.00 s to 320.00 s or ∞ (disabled)	Increments 0.01 s
Pickup current 50Ns-1 for sensitive transformer for normal 1-A transformer for normal 5-A transformer	0.001 A to 1.500 A 0.05 A to 35.00 A 0.25 A to 175.00 A	Increments 0.001 A Increments 0.01 A Increments 0.05 A
Delay Time T_{50N-1}	0.00 s to 320.00 s or ∞ (disabled)	Increments 0.01 s
Dropout delay time 50Ns T DROP-OUT	0.00 s to 60.00 s	Increments 0.01 s
Operating Time	≤ 50 ms	
Dropout ratio	Approx. 0.95 for 50Ns-1 > 50 mA	
Measurement Tolerance	2 % of setting value or 1 mA	
Operating Time Tolerance	1 % of setting value or 20 ms	

Ground Fault Pickup for All Types of Ground Faults (Inverse Time Characteristic)

User-defined Curve (defined by a maximum of 20 value pairs of current and time delay)		
Pickup Current 51Ns for sensitive transformer for normal 1-A transformer for normal 5-A transformer	0.001 A to 1.400 A 0.05 A to 4.00 A 0.25 A to 20.00 A	Increments 0.001 A Increments 0.01 A Increments 0.05 A
Time multiplier T_{51Ns}	0.10 s to 4.00 s or ∞ (disabled)	Increments 0.01 s
Pickup Threshold	Approx. $1.10 \cdot I_{51Ns}$	
Dropout ratio	Approx. $1.05 \cdot I_{51Ns}$ for $I_{51Ns} > 50$ mA	
Measurement Tolerance	2 % of setting value or 1 mA	
Operating Time Tolerance in Linear Range	7 % of reference value for $2 \leq I/I_{51Ns} \leq 20 + 2$ % current tolerance, or 70 ms	

Ground Fault Pickup for All Types of Ground Faults (Inverse Time Characteristic Logarithmic inverse)

Pickup Current 50Ns For sensitive transformer For normal 1-A transformer For normal 5-A transformer	0.001 A to 1.400 A 0.05 A to 4.00 A 0.25 A to 20.00 A	Increments 0.001 A Increments 0.01 A Increments 0.05 A
Starting current factor 51Ns Startpoint	1.0 to 4.0	Increments 0.1
Time factor 51Ns TIME DIAL	0.05 s to 15.00 s; ∞	Increments 0.01 s
Maximum time 51Ns Tmax	0.00 s to 30.00 s	Increments 0.01 s
Minimum time 51Ns Tmin	0.00 s to 30.00 s	Increments 0.01 s
Characteristics	see Figure 2-51	
Tolerances Times	inv.	5 % \pm 15 ms for $2 \leq I/I_{51Ns} \leq 20$ and 51Ns TIME DIAL ≥ 1 s
	def.	1 % of setting value or 10 ms

Ground Fault Pickup for All Types of Ground Faults (Inverse Time Characteristic Logarithmic Inverse with Knee Point)

Pickup Current 50Ns for sensitive transformer for normal 1-A transformer for normal 5-A transformer	0.003 A to 0.500 A 0.05 A to 4.00 A 0.25 A to 20.00 A	Increments 0.001 A Increments 0.01 A Increments 0.05 A
Minimum time 51Ns T min	0.10 s to 30.00 s	Increments 0.01 s
Pickup current 51Ns I T min for sensitive transformer for normal 1-A transformer for normal 5-A transformer	0.003 A to 1.400 A 0.05 A to 20.00 A 0.25 A to 100.00 A	Increments 0.001 A Increments 0.01 A Increments 0.05 A
Knee-point time 51Ns T knee	0.20 s to 100.00 s	Increments 0.01 s
Pickup current 51Ns I T knee for sensitive transformer for normal 1-A transformer for normal 5-A transformer	0.003 A to 0.650 A 0.05 A to 17.00 A 0.25 A to 85.00 A	Increments 0.001 A Increments 0.01 A Increments 0.05 A
Maximum time 51Ns T max	0.00 s to 30.00 s	Increments 0.01 s
Time factor 51Ns TD	0.05 s to 1.50 s	Increments 0.01 s
Characteristics	see Figure 2-52	
Tolerances	inv.	5 % ± 15 ms
Times	def.	1 % of setting value or 10 ms

Influencing Variables

Power Supply DC Voltage in Range $0.8 \leq V_{PS}/V_{PSNom} \leq 1.15$	1 %
Temperature in Range $23.00\text{ °F } (-5\text{ °C}) \leq \theta_{amb} \leq 131.00\text{ °F } (55\text{ °C})$	0.5 %/10 K
Frequency in range $f_{Nom} \pm 5\text{ Hz}$	1 %
Harmonics	
- Up to 10 % 3rd harmonic	1 %
- Up to 10 % 5th harmonic	1 %
Note: When using the sensitive transformer, the linear range of the measuring input for the sensitive ground fault detection is from 0.001 A to 1.6 A. The function is however still preserved for greater currents.	

Logarithmic Inverse Trip Time Characteristics

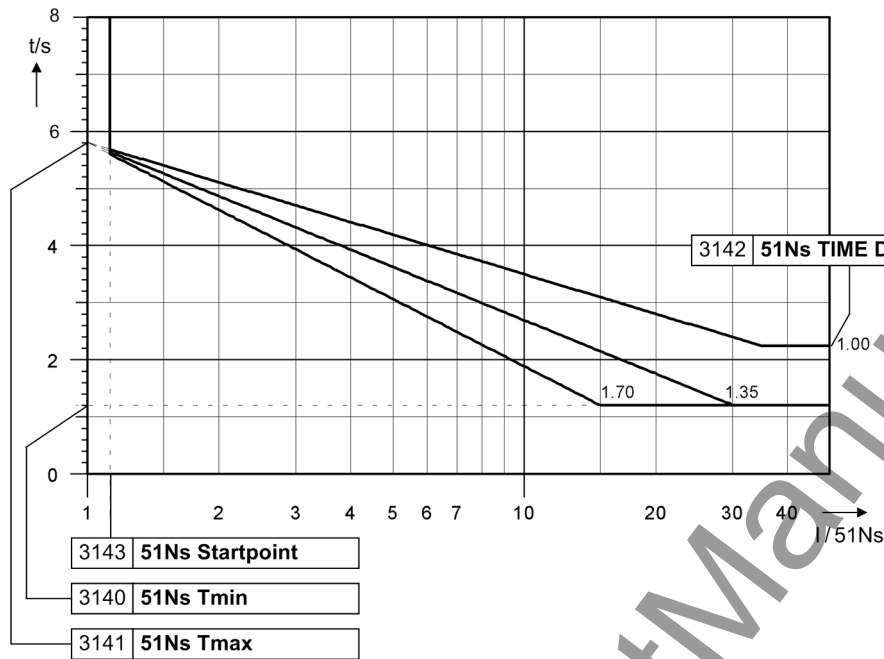

Figure 4-11 Trip time characteristics of inverse time ground fault protection with logarithmic inverse characteristic

Logarithmic inverse $t = 51Ns \text{ MAX. TIME DIAL} - 51Ns \text{ TIME DIAL} \cdot \ln(I/51Ns \text{ PICKUP})$

Note: For $I/51Ns \text{ PICKUP} > 35$ the time applies for $I/51Ns \text{ PICKUP} = 35$

Logarithmic Inverse Trip Time characteristic with knee point

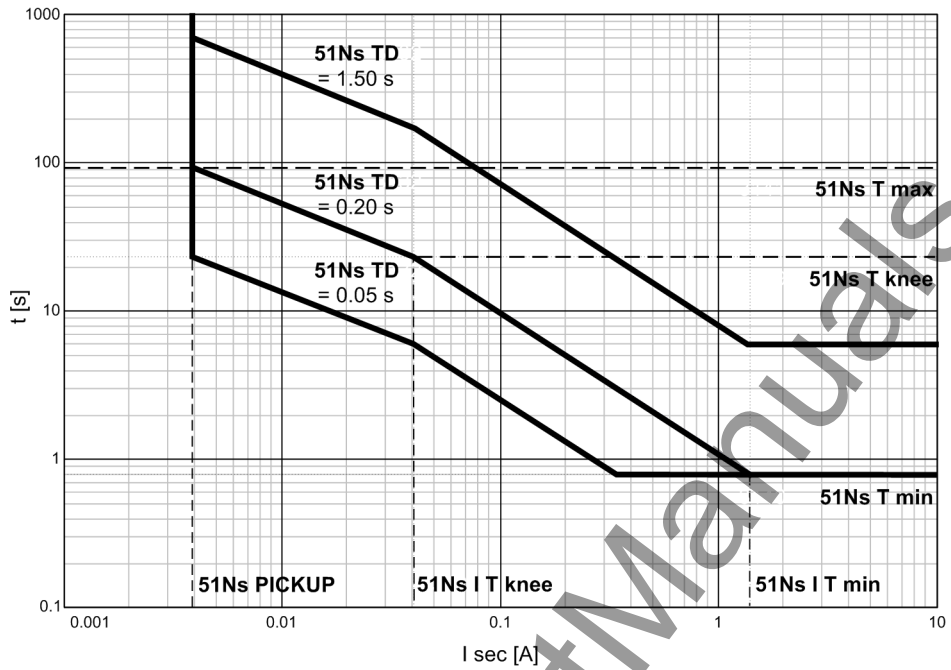

Figure 4-12 Trip-time characteristics of the inverse-time ground fault protection 51Ns with logarithmic inverse characteristic with knee point (example for 51Ns = 0.004 A)

4.14 Intermittent Ground Fault Protection

Setting Ranges / Increments

Pickup Threshold with IN	for $I_{Nom} = 1\text{ A}$	0.05 A to 35.00 A	Increments 0.01 A
	for $I_{Nom} = 5\text{ A}$	0.25 A to 175.00 A	Increments 0.01 A
with 3I0	for $I_{Nom} = 1\text{ A}$	0.05 A to 35.00 A	Increments 0.01 A
	for $I_{Nom} = 5\text{ A}$	0.25 A to 175.00 A	Increments 0.01 A
with INs		0.005 A to 1.500 A	Increments 0.001 A
Pickup extension time T_v		0.00 s to 10.00 s	Increments 0.01 s
Ground Fault Accumulation Time T_{sum}		0.00 s to 100.00 s	Increments 0.01 s
Reset Time for Accumulation T_{res}		1 s to 600 s	Increments 1 s
Number of Pickups for Intermittent Ground Fault		2 to 10	Increments 1

Times

Pickup Times	Approx. 30 ms
– Current = 1.25 x Pickup Value	Approx. 22 ms
– for $\geq 2 \cdot$ Pickup Value	Approx. 22 ms
Dropout Time (without extension time)	Approx. 22 ms

Tolerances

Pickup threshold I	3 % of set value or 10 mA for $I_{Nom} = 1\text{ A}$ or 50 mA for $I_{Nom} = 5\text{ A}$
Times T_v, T_{sum}, T_{res}	1 % of setting value or 10 ms

Influencing Variables

Power supply direct voltage in range $0.8 \leq V_{PS}/V_{PSNom} \leq 1.15$	<1 %
Temperature in range $-5\text{ °C} \leq \theta_{amb} \leq 55\text{ °C}$	<0.5 %/ K
Frequency in range $0.95 \leq f/f_{Nom} \leq 1.05$	<5% relating to the set time

4.15 Automatic Reclosing System 79

Number of Reclosures	0 to 9 (segregated into phase and ground settings) Cycles 1 to 4 can be adjusted individually	
The following Protective Functions initiate the AR 79 (no 79 start / 79 start / 79 blocked)	50-3, 50-2, 50-1, 51, 50N-3, 50N-2, 50N-1, 51N, Sensitive Ground Fault Protection, 46, Binary Inputs	
Blocking of 79 by	Pickup of protective elements for which 79 blocking is set (see above)	
	Three phase pickup (optional)	
	Binary Input	
	Last TRIP command after the reclosing cycles is complete (unsuccessful reclosing)	
	CLOSE Command of the breaker failure protection	
	Opening the circuit breaker without 79	
	External CLOSE Command	
Dead Time T_{Dead} (separate for phase and ground and individual for shots 1 to 4)	0.01 s to 320.00 s	Increments 0.01 s
	Using binary input with time monitoring	
Extension of Dead Time	Using binary input with time monitoring	
Blocking Duration for Manual-CLOSE Detection $T_{Blk Manual Close}$	0.50 s to 320.00 s or ∞	Increments 0.01 s
Blocking Duration after Manual Close $T_{Blocking Time}$	0.50 s to 320.00 s	Increments 0.01 s
Blocking Duration after Dynamic Blocking $T_{Blk Dyn}$	0.01 s to 320.00 s	Increments 0.01 s
Start Signal Monitoring Time $T_{Start Monitor}$	0.01 s to 320.00 s or ∞	Increments 0.01 s
Circuit Breaker Monitoring Time $T_{CB Monitor}$	0.10 s to 320.00 s	Increments 0.01 s
Maximum Dead Time Extension $T_{Dead Exten}$	0.50 s to 320.00 s or ∞	Increments 0.01 s
Start delay of dead time	Using binary input with time monitoring	
Max. start delay of dead time $T_{Dead delay}$	0.0 s to 1800.0 s or ∞	Increments 1.0 s
Operating time T_{Operat}	0.01 s to 320.00 s or ∞	Increments 0.01 s
The following protection functions can be influenced by the automatic reclosing function individually for the cycles 1 to 4 (setting value $T=T$ / instantaneous $T=0$ / blocked $T=infinite$):	50-3, 50-2, 50-1, 51, 50N-3, 50N-2, 50N-1, 51N	
Additional Functions	Lockout (Final Trip) Circuit breaker monitoring using breaker auxiliary contacts	

4.16 Breaker Failure Protection 50BF

Setting Ranges / Increments

Pickup threshold 50-1 BF	for $I_{Nom} = 1 \text{ A}$	0.05 A to 20.00 A	Increment 0.01 A
	for $I_{Nom} = 5 \text{ A}$	0.25 A to 100.00 A	Increment 0.01 A
Pickup threshold 50N-1 BF	for $I_{Nom} = 1 \text{ A}$	0.05 A to 20.00 A	Increment 0.01 A
	for $I_{Nom} = 5 \text{ A}$	0.25 A to 100.00 A	Increment 0.01 A
Delay time 50 BF trip timer		0.06 s to 60.00 s or ∞	Increments 0.01 s

Times

Pickup Times – On Internal Start – For external Start	included in time delay included in time delay
Dropout Time	Approx. 25 ms ¹⁾

Tolerances

Pickup thresholds 50-1 BF, 50N-1 BF	2 % of setting value; or 10 mA for $I_{Nom} = 1 \text{ A}$ or 50 mA for $I_{Nom} = 5 \text{ A}$
Time Delay TRIP-Timer	1 % or 20 ms

Influencing Variables for Pickup Values

Power supply direct voltage in range $0.8 \leq V_{PS}/V_{PSNom} \leq 1.15$	1 %
Temperature in range $23.00 \text{ °F} (-5 \text{ °C}) \leq \theta_{amb} \leq 131.00 \text{ °F} (55 \text{ °C})$	0.5 %/10 K
Frequency in range $f_{Nom} \pm 5 \text{ Hz}$	1 %
Harmonics - up to 10 % 3rd harmonic - up to 10 % 5th harmonic	1 % 1 %

¹⁾ A further delay for the current may be caused by compensation in the CT secondary circuit.

4.17 Flexible Protection Functions

Measured Quantities / Modes of Operation

Three-phase	$I, I_N, I_{Ns}, 3I_0, I_1, I_2$
Single-phase	I, I_N, I_{Ns}
Without fixed phase reference	Binary Input
Measuring procedure for I	Fundamental Harmonic True RMS (Effective Value) Positive Sequence System, Negative Sequence System,
Pickup on	Exceeding threshold or falling below threshold

Setting Ranges / Increments

Pickup thresholds:			
Current $I, I_1, I_2, 3I_0, I_N$	for $I_{Nom} = 1 \text{ A}$	0.05 to 35.00 A	Increments 0.01 A
	for $I_{Nom} = 5 \text{ A}$	0.25 to 175.00 A	
Relationship I_2/I_1		15% to 100%	Increments 1%
Sensitive ground current I_{GG}		0.001 to 1.500 A	Increments 0.001 A
Pickup delay (standard)		0.00 to 60.00 s	Increments 0.01 s
Pickup delay for I_2/I_1		0.00 to 28800.00 s	Increments 0.01 s
Command delay time		0.00 to 3600.00 s	Increments 0.01 s
Dropout delay		0.00 to 60.00 s	Increments 0.01 s

Times

Pickup times:	
Current (phase quantities) for 2 x setting value for 10 x setting value	Approx. 30 ms Approx. 20 ms
Current (symmetrical components) for 2 x setting value for 10 x setting value	Approx. 40 ms Approx. 30 ms
Binary Input	Approx. 20 ms
Dropout times:	
Current (phase quantities)	< 20 ms
Current (symmetrical components)	< 30 ms
Binary Input	< 10 ms

Tolerances

Pickup thresholds:		
Current	for $I_{Nom} = 1 \text{ A}$	1% of setting value or 10 mA
	for $I_{Nom} = 5 \text{ A}$	1% of setting value or 50 mA
Current (symmetrical components)	for $I_{Nom} = 1 \text{ A}$	2% of setting value or 20 mA
	for $I_{Nom} = 5 \text{ A}$	2% of setting value or 100 mA
Current I_2/I_1		2% of setting value
Times		1% of set value or 10 ms

Influencing Variables for Pickup Values

Power supply direct voltage in range $0.8 \leq V_{PS}/V_{PSNom} \leq 1.15$	1 %
Temperature in range $23.00 \text{ °F} (-5 \text{ °C}) \leq \Theta_{amb} \leq 131.00 \text{ °F} (55 \text{ °C})$	0.5 %/10 K
Frequency in range $f_{Nom} \pm 5 \text{ Hz}$	1 %
Harmonics	
- up to 10 % 3rd harmonic	1 %
- up to 10 % 5th harmonic	1 %

4.18 Temperature Detection via RTD Boxes

Temperature Detectors

Connectable RTD-boxes	1 or 2
Number of temperature detectors per RTD-box	Max. 6
Measuring method	Pt 100 Ω or Ni 100 Ω or Ni 120 Ω selectable 2 or 3 phase connection
Mounting identification	„Oil“ or „Ambient“ or „Stator“ or „Bearing“ or „Other“

Operational Measured Values

Number of measuring points	Maximal of 12 temperature measuring points
Temperature Unit	$^{\circ}\text{C}$ or $^{\circ}\text{F}$, adjustable
Measuring Range	<ul style="list-style-type: none"> – for Pt 100 $-199\text{ }^{\circ}\text{C}$ to $800\text{ }^{\circ}\text{C}$ ($-326\text{ }^{\circ}\text{F}$ to $1472\text{ }^{\circ}\text{F}$) – for Ni 100 $-54\text{ }^{\circ}\text{C}$ to $278\text{ }^{\circ}\text{C}$ ($-65\text{ }^{\circ}\text{F}$ to $532\text{ }^{\circ}\text{F}$) – for Ni 120 $-52\text{ }^{\circ}\text{C}$ to $263\text{ }^{\circ}\text{C}$ ($-62\text{ }^{\circ}\text{F}$ to $505\text{ }^{\circ}\text{F}$)
Resolution	$1\text{ }^{\circ}\text{C}$ or $1\text{ }^{\circ}\text{F}$
Tolerance	$\pm 0.5\%$ of measured value ± 1 digit

Thresholds for Indications

for each measuring point		
Stage 1	<ul style="list-style-type: none"> $-50\text{ }^{\circ}\text{C}$ to $250\text{ }^{\circ}\text{C}$ $-58\text{ }^{\circ}\text{F}$ to $482\text{ }^{\circ}\text{F}$ or ∞ (no message) 	<ul style="list-style-type: none"> (increment $1\text{ }^{\circ}\text{C}$) (increment $1\text{ }^{\circ}\text{F}$)
Stage 2	<ul style="list-style-type: none"> $-50\text{ }^{\circ}\text{C}$ to $250\text{ }^{\circ}\text{C}$ $-58\text{ }^{\circ}\text{F}$ to $482\text{ }^{\circ}\text{F}$ or ∞ (no message) 	<ul style="list-style-type: none"> (increment $1\text{ }^{\circ}\text{C}$) (increment $1\text{ }^{\circ}\text{F}$)

4.19 User-defined Functions (CFC)

Function Modules and Possible Assignments to Task Levels

Function Module	Explanation	Task Level			
		MW_ BEARB	PLC1_ BEARB	PLC_ BEARB	SFS_ BEARB
ABSVALUE	Magnitude Calculation	X	—	—	—
ADD	Addition	X	X	X	X
ALARM	Alarm clock	X	X	X	X
AND	AND - Gate	X	X	X	X
FLASH	Blink block	X	X	X	X
BOOL_TO_CO	Boolean to Control (conversion)	—	X	X	—
BOOL_TO_DI	Boolean to Double Point (conversion)	—	X	X	X
BOOL_TO_IC	Bool to Internal SI, Conversion	—	X	X	X
BUILD_DI	Create Double Point Annunciation	—	X	X	X
CMD_CANCEL	Command cancelled	X	X	X	X
CMD_CHAIN	Switching Sequence	—	X	X	—
CMD_INF	Command Information	—	—	—	X
COMPARE	Metered value comparison	X	X	X	X
CONNECT	Connection	—	X	X	X
COUNTER	Counter	X	X	X	X
DI_GET_STATUS	Decode double point indication	X	X	X	X
DI_SET_STATUS	Generate double point indication with status	X	X	X	X
D_FF	D- Flipflop	—	X	X	X
D_FF_MEMO	Status Memory for Restart	X	X	X	X
DI_TO_BOOL	Double Point to Boolean (conversion)	—	X	X	X
DINT_TO_REAL	Adaptor	X	X	X	X
DIST_DECODE	Conversion double point indication with status to four single indications with status	X	X	X	X
DIV	Division	X	X	X	X
DM_DECODE	Decode Double Point	X	X	X	X
DYN_OR	Dynamic OR	X	X	X	X
INT_TO_REAL	Conversion	X	X	X	X
LIVE_ZERO	Live-zero, non-linear Curve	X	—	—	—
LONG_TIMER	Timer (max.1193h)	X	X	X	X
LOOP	Feedback Loop	X	X	—	X
LOWER_SETPOINT	Lower Limit	X	—	—	—

Function Module	Explanation	Task Level			
		MW_ BEARB	PLC1_ BEARB	PLC_ BEARB	SFS_ BEARB
MUL	Multiplication	X	X	X	X
MV_GET_STATUS	Decode status of a value	X	X	X	X
MV_SET_STATUS	Set status of a value	X	X	X	X
NAND	NAND - Gate	X	X	X	X
NEG	Negator	X	X	X	X
NOR	NOR - Gate	X	X	X	X
OR	OR - Gate	X	X	X	X
REAL_TO_DINT	Adaptor	X	X	X	X
REAL_TO_INT	Conversion	X	X	X	X
REAL_TO_UINT	Conversion	X	X	X	X
RISE_DETECT	Rise detector	X	X	X	X
RS_FF	RS- Flipflop	—	X	X	X
RS_FF_MEMO	RS- Flipflop with state memory	—	X	X	X
SQUARE_ROOT	Root Extractor	X	X	X	X
SR_FF	SR- Flipflop	—	X	X	X
SR_FF_MEMO	SR- Flipflop with state memory	—	X	X	X
ST_AND	AND gate with status	X	X	X	X
ST_NOT	Inverter with status	X	X	X	X
ST_OR	OR gate with status	X	X	X	X
SUB	Substraction	X	X	X	X
TIMER	Timer	—	X	X	—
TIMER_SHORT	Simple timer	—	X	X	—
UINT_TO_REAL	Conversion	X	X	X	X
UPPER_SETPOINT	Upper Limit	X	—	—	—
X_OR	XOR - Gate	X	X	X	X
ZERO_POINT	Zero Supression	X	—	—	—

General Limits

Description	Limit	Comments
Maximum number of all CFC charts considering all task levels	32	When the limit is exceeded, the device rejects the parameter set displaying an error message, restores the last valid parameter set and uses it for restarting.
Maximum number of all CFC charts considering one task level	16	When the limit is exceeded, an error message is output by the device. Consequently, the device is put into monitoring mode. The red ERROR-LED lights up.
Maximum number of all CFC inputs considering all charts	400	When the limit is exceeded, an error message is output by the device. Consequently, the device starts monitoring. The red ERROR-LED lights up.
Maximum number of reset-resistant flipflops D_FF_MEMO	350	When the limit is exceeded, an error message is output by the device. Consequently, the device starts monitoring. The red ERROR-LED lights up.

Device-specific Limits

Description	Limit	Comments
Maximum number of synchronous changes of chart inputs per task level	165	When the limit is exceeded, an error message is output by the device. Consequently, the device starts monitoring. The red ERROR-LED lights up.
Maximum number of chart outputs per task level	150	

Additional Limits

Additional limits ¹⁾ for the following CFC blocks:		
Run-Time Level	Maximum Number of Modules in the Task Levels	
	TIMER ^{2) 3)}	TIMER_SHORT ^{2) 3)}
MW_BEARB	—	—
PLC1_BEARB	15	30
PLC_BEARB		
SFS_BEARB	—	—

- 1) When the limit is exceeded, an error message is output by the device. Consequently, the device starts monitoring. The red ERROR-LED lights up.
- 2) The following condition applies for the maximum number of timers: $(2 \cdot \text{number of TIMER} + \text{number of TIMER_SHORT}) < 30$. TIMER and TIMER_SHORT hence share the available timer resources within the frame of this inequation. The limit does not apply to the LONG_TIMER.
- 3) The time values for the blocks TIMER and TIMER_SHORT must not be selected shorter than the time resolution of the device, as the blocks will not then start with the starting pulse.

Maximum Number of TICKS in the Task Levels

Run-Time Level	Limit in TICKS ¹⁾
MW_BEARB (Measured Value Processing)	10000
PLC1_BEARB (Slow PLC processing)	4000
PLC_BEARB (Fast PLC Processing)	400
SFS_BEARB (Interlocking)	10000

- 1) When the sum of TICKS of all blocks exceeds the limits before-mentioned, an error message is output by CFC.

Processing Times in TICKS Required by the Individual Elements

Individual Element		Number of TICKS
Block, basic requirement		5
Each input more than 3 inputs for generic modules		1
Connection to an input signal		6
Connection to an output signal		7
Additional for each chart		1
Arithmetic	ABS_VALUE	5
	ADD	26
	SUB	26
	MUL	26
	DIV	54
	SQUARE_ROOT	83
	Basic logic	AND
CONNECT		4
DYN_OR		6
NAND		5
NEG		4
NOR		5
OR		5
RISE_DETECT		4
X_OR		5
Information status	SI_GET_STATUS	5
	CV_GET_STATUS	5
	DI_GET_STATUS	5
	MV_GET_STATUS	5
	SI_SET_STATUS	5
	DI_SET_STATUS	5
	MV_SET_STATUS	5
	ST_AND	5
	ST_OR	5
	ST_NOT	5
	Memory	D_FF
D_FF_MEMO		6
RS_FF		4
RS_FF_MEMO		4
SR_FF		4
SR_FF_MEMO		4
Control commands		BOOL_TO_CO
	BOOL_TO_IC	5
	CMD_INF	4
	CMD_CHAIN	34
	CMD_CANCEL	3
	LOOP	8

	Individual Element	Number of TICKS
Type converter	BOOL_TO_DI	5
	BUILD_DI	5
	DI_TO_BOOL	5
	DM_DECODE	8
	DINT_TO_REAL	5
	DIST_DECODE	8
	UINT_TO_REAL	5
	REAL_TO_DINT	10
	REAL_TO_UINT	10
Comparison	COMPARE	12
	LOWER_SETPOINT	5
	UPPER_SETPOINT	5
	LIVE_ZERO	5
	ZERO_POINT	5
Metered value	COUNTER	6
Time and clock pulse	TIMER	5
	TIMER_LONG	5
	TIMER_SHORT	8
	ALARM	21
	FLASH	11

Configurable in Matrix

In addition to the defined preassignments, indications and measured values can be freely configured to buffers, preconfigurations can be removed.

4.20 Additional Functions

Operational Measured Values

Currents $I_A; I_B; I_C$ Positive sequence component I_1 Negative sequence component I_2 I_N or $3I_0$	in A (kA) primary and in A secondary or in % I_{Nom}
Range Tolerance ¹⁾	10 % to 200 % I_{Nom} 1 % of measured value or 0.5 % I_{Nom}
Temperature Overload Protection Θ / Θ_{Trip}	in %.
Range Tolerance ¹⁾	0 % to 400 % 5% class accuracy per IEC 60255-8
Temperature Restart Inhibit $\Theta_L / \Theta_{L Trip}$	in %.
Range Tolerance ¹⁾	0 % to 400 % 5% class accuracy per IEC 60255-8
Restart Threshold $\Theta_{Restart} / \Theta_{L Trip}$	in %.
Reclose time $T_{Reclose}$	in min
RMS Current Value of Sensitive Ground Fault Detection I_{Ns}	in A (kA) primary and in mA secondary
Range Tolerance ¹⁾	0 mA to 1600 mA 2 % of measured value or 1 mA
RTD-Box	See section „RTD-Boxes for Temperature Detection“

¹⁾ At nominal frequency

Long-Term Averages

Time Window	5, 15, 30 or 60 minutes
Frequency of Updates	Adjustable
Long-Term Averages $I_{Admd}; I_{Bdmd}; I_{Cdmd}; I_{1dmd}$	in A; kA

Min / Max Report

Report of Measured Values	With date and time
Reset automatic	Time of day adjustable (in minutes, 0 to 1439 min) Time frame and starting time adjustable (in days, 1 to 365 days, and ∞)
Manual Reset	Using binary input Using keypad Using communication
Min/Max Values	$I_A; I_B; I_C;$ I_1 (positive sequence component)
Min/Max Values of the Overload Protection	Θ / Θ_{Trip}
Min/Max Values of Averages	$I_{Admd}; I_{Bdmd}; I_{Cdmd};$ I_{1dmd} (positive sequence component);

Local Measured Values Monitoring

Current Asymmetry	$I_{max}/I_{min} > \text{balance factor, for } I > I_{balance \text{ limit}}$
Total current, quick monitoring function with protection blockage	$ i_A + i_B + i_C + k_I \cdot i_E > \text{limit value}$
Current Phase Sequence	Clockwise (ABC) / counter-clockwise (ACB)
Limit Value Monitorings	$I_A > \text{limit value } I_{Admd}>$ $I_B > \text{limit value } I_{Bdmd}>$ $I_C > \text{limit value } I_{Cdmd}>$ $I_1 > \text{limit value } I_{1dmd}>$ $I_L < \text{limit value } I_{L<}$

Fault Event Recording

Recording of indications of the last 8 power system faults
--

Time Allocation

Resolution for Event Log (Operational Annunciations)	1 ms
Resolution for Trip Log (Fault Annunciations)	1 ms
Maximum Time Deviation (Internal Clock)	0.01 %
Battery	Lithium battery 3 V/1 Ah, type CR 1/2 AA Message „Battery Fault“ for insufficient battery charge

Fault Recording

maximum of 8 fault records saved; memory maintained by buffer battery in case of loss of power supply	
Recording Time	Total 20 s Pre-event and post-event recording and memory time adjustable
Probing	16 samples (instantaneous values) per cycle

Statistics

Saved Number of Trips	Up to 9 digits
Number of Automatic Reclosing Commands (segregated according to 1st and \geq 2nd cycle)	Up to 9 digits
Accumulated Interrupted Current (segregated according to pole)	Up to 4 digits

Motor Statistics

Total number of motor startups	0 to 9999	Resolution 1
Total operating time	0 to 99999 h	Resolution 1 h
Total down-time	0 to 99999 h	Resolution 1 h
Ratio operating time / down-time	0 to 100 %	Resolution 0.1 %
Motor startup data: – Startup time – Startup current (primary)	of the last 5 startups 0.30 s to 9999.99 s 0 A to 1000 kA	Resolution 10 ms Resolution 1 A

Operating Hours Counter

Display Range	Up to 7 digits
Criterion	Overshoot of an adjustable current threshold (element 50-1, BkrClosed I MIN)

Circuit Breaker Maintenance

Calculation methods	on true r.m.s value basis: ΣI , ΣI^x , 2P; on instantaneous value basis: I^2t
Acquisition/conditioning of measured values	phase-selective
Evaluation	one threshold per subfunction
Number of saved statistic values	up to 13 digits

Trip Circuit Monitoring

With one or two binary inputs.

Commissioning Aids

<ul style="list-style-type: none"> - Phase rotation field check - Operational measured values - Circuit breaker test by means of control function - Creation of a test measurement report

Clock

Time Synchronization	DCF 77/IRIG B-Signal (telegram format IRIG-B000) Binary Input Communication	
Operating Modes for Time Tracking		
No.	Operating Mode	Explanations
1	Internal	Internal synchronization using RTC (presetting)
2	IEC 60870-5-103	External synchronization using system interface (IEC 60870-5-103)
3	PROFIBUS FMS	External synchronization using PROFIBUS interface
4	Time signal IRIG B	External synchronization using IRIG B
5	Time signal DCF77	External synchronization using DCF 77
6	Time signal Sync. Box	External synchronization via the time signal SIMEAS-Synch.Box
7	Pulse via binary input	External synchronization with pulse via binary input
8	Field bus (DNP, Modbus)	External synchronization using field bus
9	NTP (IEC 61850)	External synchronization using system interface (IEC 61850)

Group Switchover of the Function Parameters

Number of Available Setting Groups	4 (parameter group A, B, C and D)
Switchover Performed	Using the keypad DIGSI using the front PC port with protocol via system (SCADA) interface Binary Input

IEC 61850 GOOSE (inter-relay communication)

The GOOSE communication service of IEC 61850 is qualified for switchgear interlocking. The runtime of GOOSE messages with the protection relay picked up depends on the number of connected IEC 61850 clients.

As from version V4.6 of the devices, applications with protective functions have to be checked with regard to their required runtime. In individual cases, the manufacturer has to be consulted with regard to the requirements to ensure that the application functions safely.

4.21 Breaker Control

Number of Controlled Switching Devices	Depends on the number of binary inputs and outputs available
Interlocking	Freely programmable interlocking
Messages	Feedback messages; closed, open, intermediate position
Control Commands	Single command / double command
Switching Command to Circuit Breaker	1-, 1½ - and 2-pole
Programmable Logic Controller	PLC logic, graphic input tool
Local Control	Control via menu control assignment of function keys
Remote Control	Using Communication Interfaces Using a substation automation and control system (e.g. SICAM) Using DIGSI (e.g. via Modem)

4.22 Dimensions

4.22.1 Panel Flush and Cubicle Mounting (Housing Size $\frac{1}{3}$)

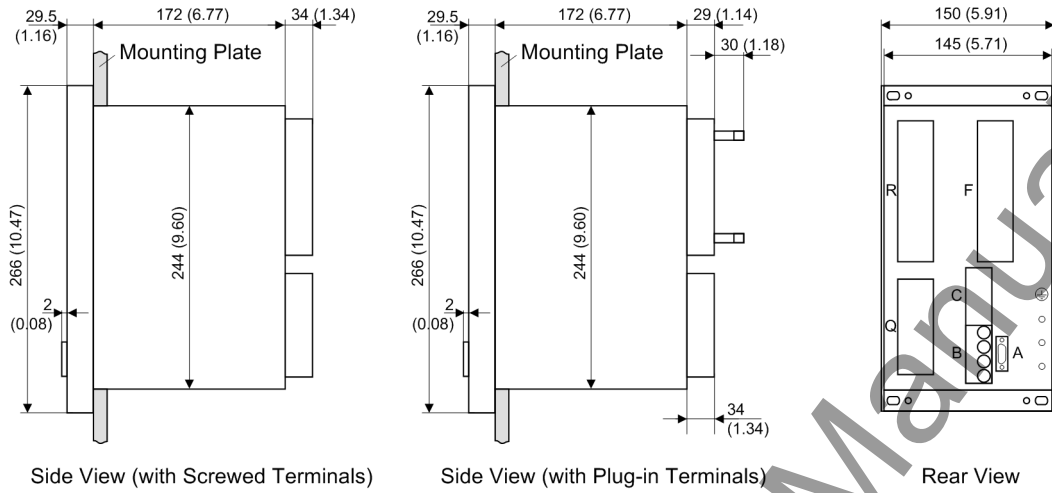

Side View (with Screwed Terminals)

Side View (with Plug-in Terminals)

Rear View

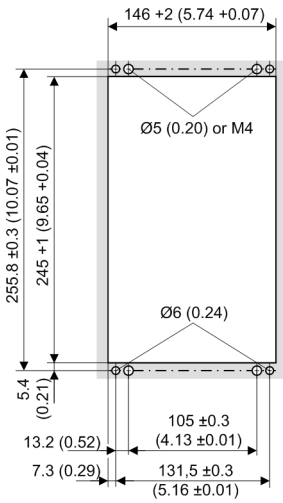

Panel Cut-Out

Dimensions in mm Values
 in Brackets in inches

Figure 4-13 Dimensional drawing of a 7SJ61 for panel flush and cubicle mounting (housing size $\frac{1}{3}$)

4.22.2 Panel Surface Mounting (Housing Size 1/3)

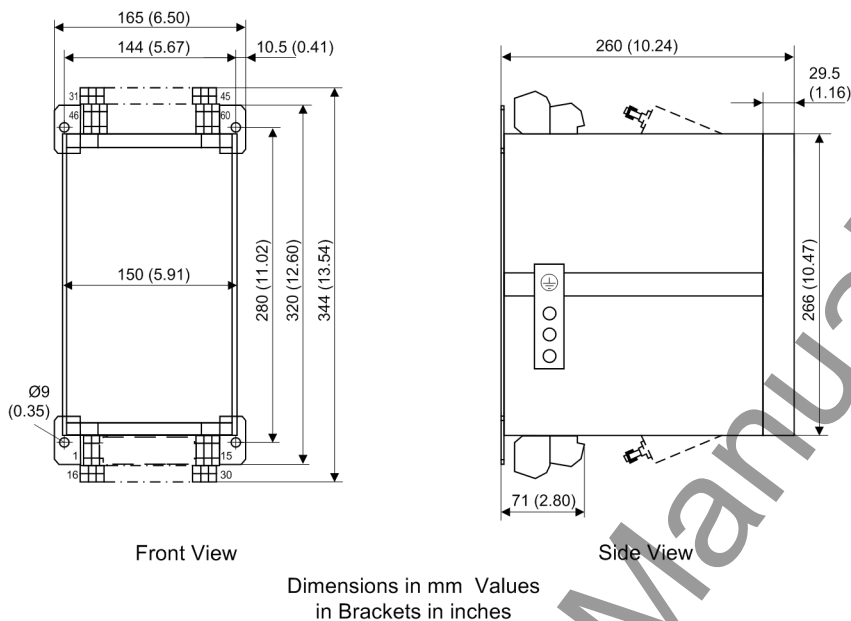

Figure 4-14 Dimensional drawing of a 7SJ61 for panel flush mounting (housing size 1/3)

4.22.3 Varistor

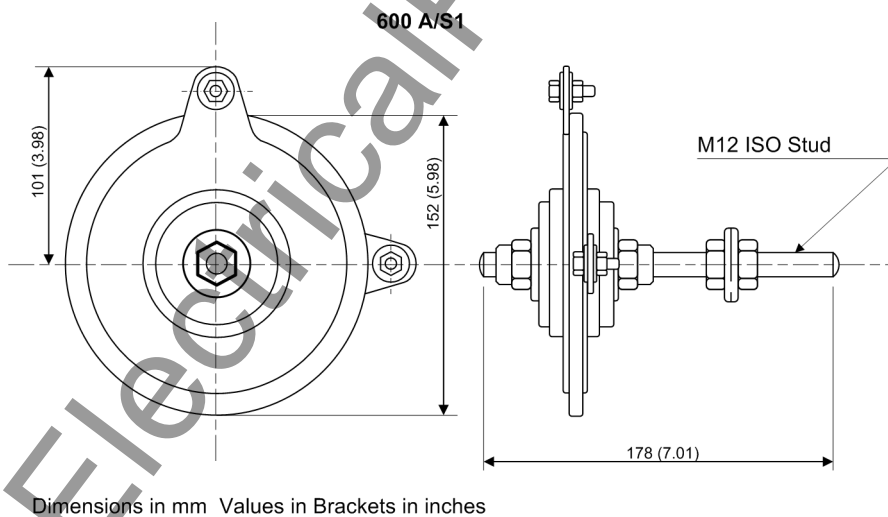

Figure 4-15 Dimensional drawing of the varistor for voltage limiting in high-impedance differential protection

www.ElectricalPartManuals.com

Appendix

www.ElectricalPartManuals.com
A

This appendix is primarily a reference for the experienced user. This section provides ordering information for the models of this device. Connection diagrams indicating the terminal connections of the models of this device are included. Following the general diagrams are diagrams that show the proper connections of the devices to primary equipment in many typical power system configurations. Tables with all settings and all information available in this device equipped with all options are provided. Default settings are also given.

A.1	Ordering Information and Accessories	370
A.2	Terminal Assignments	376
A.3	Connection Examples	385
A.4	Current Transformer Requirements	391
A.5	Default Settings	394
A.6	Protocol-dependent Functions	399
A.7	Functional Scope	400
A.8	Settings	402
A.9	Information List	415
A.10	Group Alarms	433
A.11	Measured Values	434

A.1 Ordering Information and Accessories

A.1.1 Ordering Information

A.1.1.1 7SJ61 V4.7

Multi-Functional Protection with Control	6	7	8	9	10	11	12	13	14	15	16	Supplementary			
	7	S	J	6	1	<input type="text"/>	<input type="text"/>	-	<input type="text"/>	<input type="text"/>	<input type="text"/>	<input type="text"/>	+	<input type="text"/>	<input type="text"/>

Number of Binary Inputs and Outputs	Position 6
3 Binary Inputs, 4 Binary Outputs, 1 Live Status Contact	0
8 Binary Inputs, 8 Binary Outputs, 1 Live Status Contact	1
11 Binary Inputs, 6 Binary Outputs, 1 Live Status Contact	2

Nominal current	Position 7
$I_{ph} = 1\text{ A}$, $I_N = 1\text{ A}$ (min. = 0.05 A); 15th position only with A	1
$I_{ph} = 1\text{ A}$, $I_N = \text{sensitive}$ (min. = 0.001 A); 15th position only with B	2
$I_{ph} = 5\text{ A}$, $I_N = 5\text{ A}$ (min. = 0.25 A); 15th position only with A	5
$I_{ph} = 5\text{ A}$, $I_N = \text{sensitive}$ (min. = 0.001 A); 15th position only with B	6
$I_{ph} = 5\text{ A}$, $I_N = 1\text{ A}$ (min. = 0.05 A); 15th position only with A	7

Auxiliary Voltage (Power Supply, Pickup Threshold of Binary Inputs)	Position 8
24 to 48 VDC, Binary Input Threshold 19 VDC	2
60 to 125 VDC, Binary Input Threshold 19 VDC	4
110 to 250 VDC, 115 to 230 VAC, Binary Input Threshold 88 VDC	5

Construction	Position 9
Surface-mounting case for panel, 2 tier terminals top/bottom	B
Flush mounting case, plug-in terminals (2/3-pole connector)	D
Flush mounting case, screw-type terminals (direct connection / ring lugs)	E

Region-specific default / language settings and function versions	Position 10
Region DE, 50 Hz, IEC, German Language (Language can be changed)	A
Region World, 50/60 Hz, IEC/ANSI, Language English (Language can be changed)	B
Region US, 60/50 Hz, ANSI, Language American English (Language can be changed)	C
Region FR, 50/60 Hz, IEC/ANSI, Language French (Language can be changed)	D
Region World, 50/60 Hz, IEC/ANSI, Language Spanish (Language can be changed)	E
Region IT, 50/60 Hz, IEC/ANSI, Language Italian (Language can be changed)	F

System Interface (Rear Side, Port B)	Position 11
No system interface	0
IEC-Protocol, electrical RS232	1
IEC-Protocol, electrical RS485	2
IEC Protocol, Optical, 820 nm, ST Connector	3
Profibus FMS Slave, electrical RS485	4
Profibus FMS Slave, Optical, Single Ring, ST-Connector ¹⁾	5 ¹⁾
Profibus FMS Slave, Optical, Double Ring, ST-Connector ¹⁾	6 ¹⁾
For further interface options see Additional Information in the following	9

Additional information to further system interfaces (Rear Side, Port B)	Supplementary
PROFIBUS DP Slave, RS 485	+ L O A
Profibus DP Slave, 820 nm, Optical Double Ring, ST-Connector ¹⁾	+ L O B ¹⁾
Modbus RS 485	+ L O D
Modbus, 820 nm, Optical, ST-Connector ²⁾	+ L O E ²⁾
DNP3.0, RS 485	+ L O G
DNP3.0, 820 nm, Optical, ST-Connector ²⁾	+ L O H ²⁾
IEC 60870-5-103 Protocol, redundant RS485 ²⁾	+ L O P ²⁾
IEC 61850, Ethernet electrical, double, RJ45-connector (EN 100)	+ L O R
IEC 61850, Ethernet optical, double, ST-connector (EN 100) ²⁾	+ L O S ²⁾

- ¹⁾ Cannot be delivered in connection with 9th digit = "B". If the optical interface is required you must order the following: 11th digit = 4 (RS 485) and in addition, the associated converter
- ²⁾ Cannot be delivered in connection with 9th digit = "B".

Converter	Order No.	Use
SIEMENS OLM ¹⁾	6GK1502-2CB10	For single ring
SIEMENS OLM ¹⁾	6GK1502-3CB10	For double ring

- ¹⁾ The converter requires an operating voltage of 24 V DC. If the available operating voltage is > 24 V DC the additional power supply 7XV5810-0BA00 is required.

DIGSI/Modem Interface (Rear Side, Port C)	Position 12
No DIGSI interface at rear side	0
DIGSI/Modem, electrical RS232	1
DIGSI/Modem/RTD-Box ¹⁾ , electrical RS485	2
DIGSI/Modem/RDS box ¹⁾ , optical 820 nm, ST-connector ²⁾	3

- ¹⁾ RTD-box 7XV5662-*AD10
- ²⁾ If you want to run the RTD-Box at an optical interface, you need also the RS485-FO-converter 7XV5650-0*A00.

Measuring/Fault Recording		Position 13
With fault recording		1
With fault recording, average values, min/max values		3

Functions			Position 14 and 15
Description	ANSI No.	Description	F A
Basic Elements (included in all versions)	—	Control	
	50/51	Time overcurrent protection phase 50-1, 50-2, 50-3, 51, reverse interlocking	
	50N/51N	Ground fault protection ground 50N-1, 50N-2, 50N-3, 51-N	
	50N/51N	Insensitive time overcurrent protection ground via SGFD function; 50Ns-1, 50Ns-2, 51Ns ¹⁾	
	50/50N	Flexible protection functions (parameters from current): additive overcurrent time protection elements 50-4	
	49	Overload protection (with 2 time constants)	
	46	Negative Sequence Protection 46-1, 46-2, 46-TOC	
	37	Undercurrent monitoring	
	50BF	Breaker Failure Protection	
	74TC	Trip Circuit Monitoring	
	—	Cold-load pickup (dynamic setting changes) 50C-1, 50C-2, 50NC-1, 50NC-2, 51NC	
	—	Inrush restraint	
	86	Lock out	
IEF	—	Intermittent ground fault	P A
	50Ns/51Ns 87N	Sensitive ground fault detection High-impedance ground fault differential protection	F B ²⁾
IEF	50Ns/51Ns — 87N	Sens. ground fault detection Intermittent ground fault High-impedance ground fault differential protection	P B ²⁾
motor IEF	50Ns/51Ns — 87N 48/14 66/86 51M	Sens. ground fault detection Intermittent ground fault High-impedance ground fault differential protection Motor starting supervision, locked rotor Restart inhibit Load jam detection in motors, motor statistics	R B ²⁾
motor	50Ns/51Ns 87N 48/14 66/86 51M	Sens. ground fault detection High-impedance ground fault differential protection Motor starting supervision, locked rotor Restart inhibit Load jam detection in motors, motor statistics	H B ²⁾
motor	48/14 66/86 51M	Motor starting supervision, locked rotor Restart inhibit Load jam detection in motors, motor statistics	H A

IEF = Intermittent ground (earth) fault protection

¹⁾ only for non-sensitive ground current transformer if 7th digit = 1, 5, 7²⁾ for isolated/compensated networks, only for sensitive ground current transformer if 7th digit = 2, 6.

Automatic Reclosing (79)			Position 16
		Without 79	0
	79	With 79	1

Special model	Supplementary
with ATEX 100 approval (for the protection of explosion-protected motors of protection type increased safety "e")	+Z X 9 9

A.1.2 Accessories

Exchangeable interface modules

Name	Order No.
RS232	C53207-A351-D641-1
RS485	C53207-A351-D642-1
FO 820 nm	C53207-A351-D643-1
Profibus FMS RS485	C53207-A351-D603-1
Profibus FMS double ring	C53207-A351-D606-1
Profibus FMS single ring	C53207-A351-D609-1
Profibus DP RS485	C53207-A351-D611-1
Profibus DP double ring	C53207-A351-D613-1
Modbus RS485	C53207-A351-D621-1
Modbus 820 nm	C53207-A351-D623-1
DNP 3.0 RS 485	C53207-A351-D631-1
DNP 3.0 820 nm	C53207-A351-D633-1
Ethernet electrical (EN 100)	C53207-A351-D675-2
Ethernet optical (EN 100)	C53207-A351-D676-1
IEC 60870-5-103 Protocol, redundant RS485	C53207-A351-D644-1

RTD-Box (Resistance Temperature Detector)

Name	Order No.
RTD-box, Vaux = 24 to 60 V AC/DC	7XV5662-2AD10-0000
RTD-box, Vaux = 90 to 240 V AC/DC	7XV5662-5AD10-0000

RS485/Fiber Optic Converter

RS485/Fiber Optic Converter	Order No.
820 nm; FC-Connector	7XV5650-0AA00
820 nm, with ST-Connector	7XV5650-0BA00

Terminal Block Covering Caps

Covering cap for terminal block type	Order No.
18-pin voltage terminal, 12-pin current terminal	C73334-A1-C31-1
12-terminal voltage, 8-terminal current block	C73334-A1-C32-1

Short Circuit Links

Short circuit links for terminal type	Order No.
Voltage terminal, 18-terminal, or 12-terminal	C73334-A1-C34-1
Current terminal, 12-terminal, or 8-terminal	C73334-A1-C33-1

Female Plugs

Connector Type	Order No.
2-pin	C73334-A1-C35-1
3-pin	C73334-A1-C36-1

Mounting Rail for 19"-Racks

Name	Order No.
Angle Strip (Mounting Rail)	C73165-A63-C200-4

Battery

Lithium battery 3 V/1 Ah, type CR 1/2 AA	Order No.
VARTA	6127 101 501

Interface Cable

Interface cable between PC or SIPROTEC device	Order No.
Cable with 9-pin male/female connections	7XV5100-4

Varistor

Voltage-limiting resistor for high-impedance differential protection

Name	Order number
125 Veff, 600 A, 1S/S256	C53207-A401-D76-1
240 Veff, 600 A, 1S/S1088	C53207-A401-D77-1

RS485 Adapter Cable

Name	Order Number
Y-adapter cable for devices with RS485 interface and sub-D connector on 2x RJ45 sub-miniature connector for a RS485 bus setup with patch cables. 2-core twisted, shielded, length 0.3 m; 1x sub-D pin 9-pole on 2x RJ45 sub-miniature connector 8-pole	7XV5103-2BA00

IEC 60870-5-103 redundant, RS485 adapter cable

Name	Order Number
Y-adapter cable for devices with redundant IEC 60870-5-103 RS485 interface and RJ45 connector on 2x RJ45 sub-miniature connector for a RS485 bus setup with patch cables. 2-core twisted, shielded, length 0.3 m; 1x RJ45 pin 8-pole on 2x RJ45 sub-miniature connector 8-pole	7XV5103-2CA00

RS485 Bus connector for RJ45

Name	Order Number
RS485 bus connector with internal resistance 220 Ω between pin 1 and pin 2; 1x RJ45 pin connector 8-pole	7XV5103-5BA00

A.2 Terminal Assignments

A.2.1 Housing for Panel Flush and Cubicle Mounting

7SJ610*-*D/E

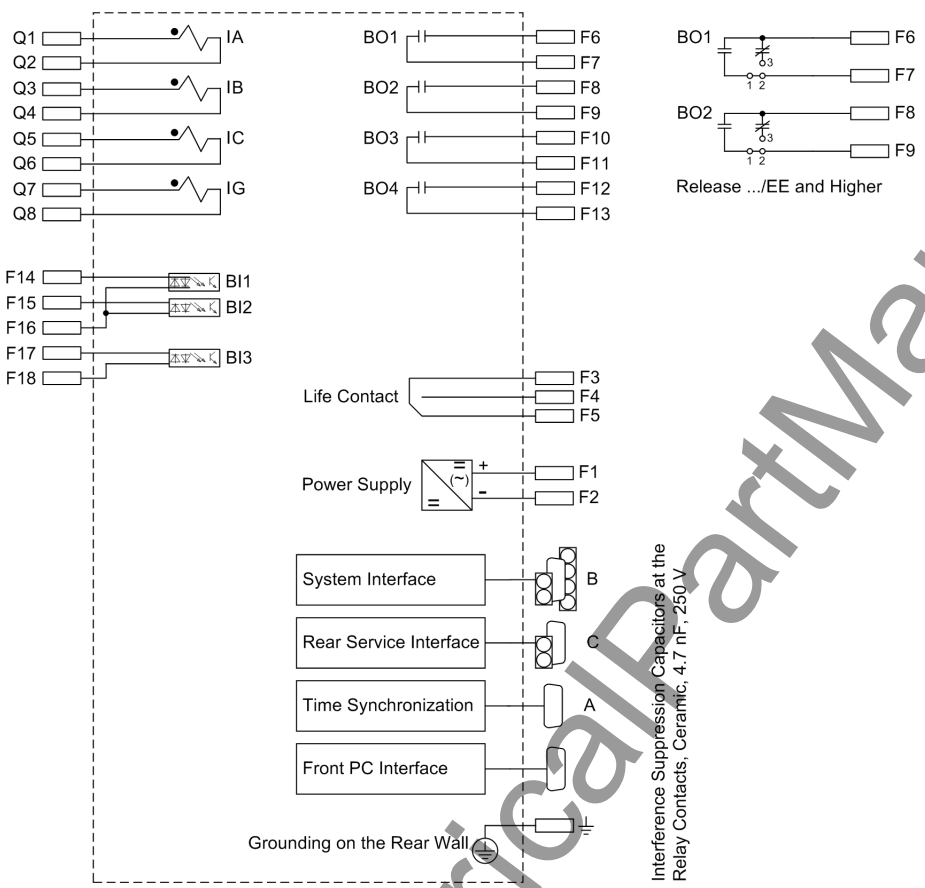

Figure A-1 Connection diagram for 7SJ610*-*D/E (panel flush mounted or cubicle mounted)

7SJ611*-*D/E

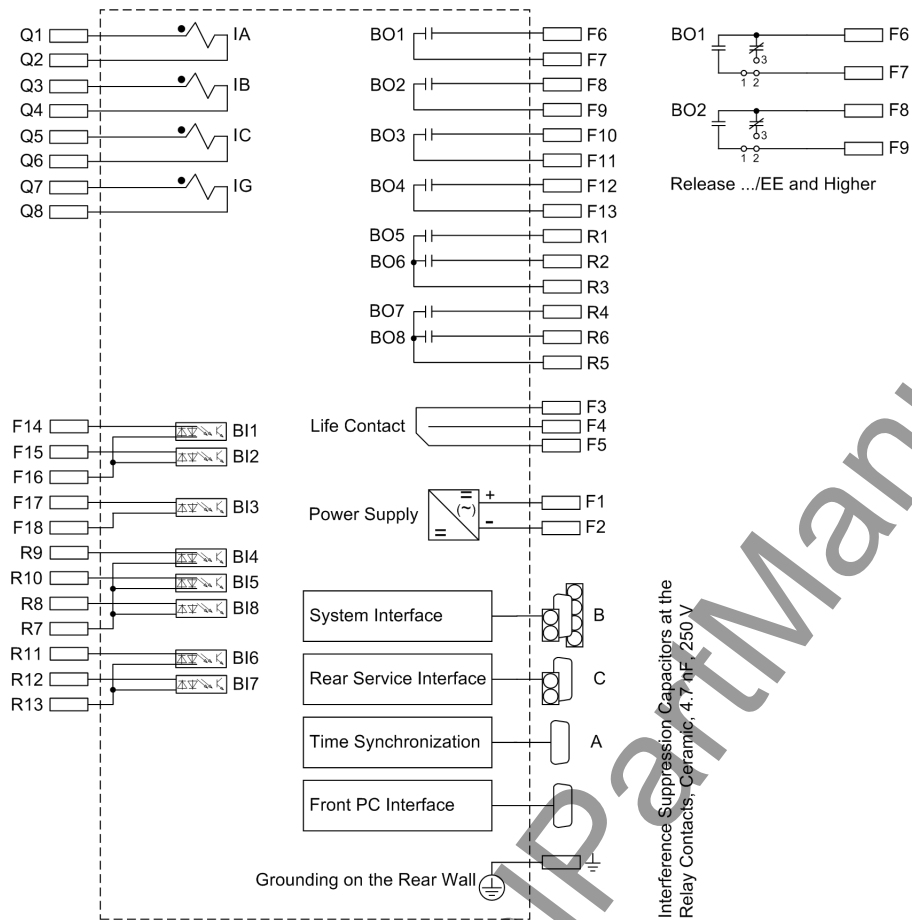

Figure A-2 Connection diagram for 7SJ611*-*D/E (panel flush mounted or cubicle mounted)

7SJ612*-*D/E

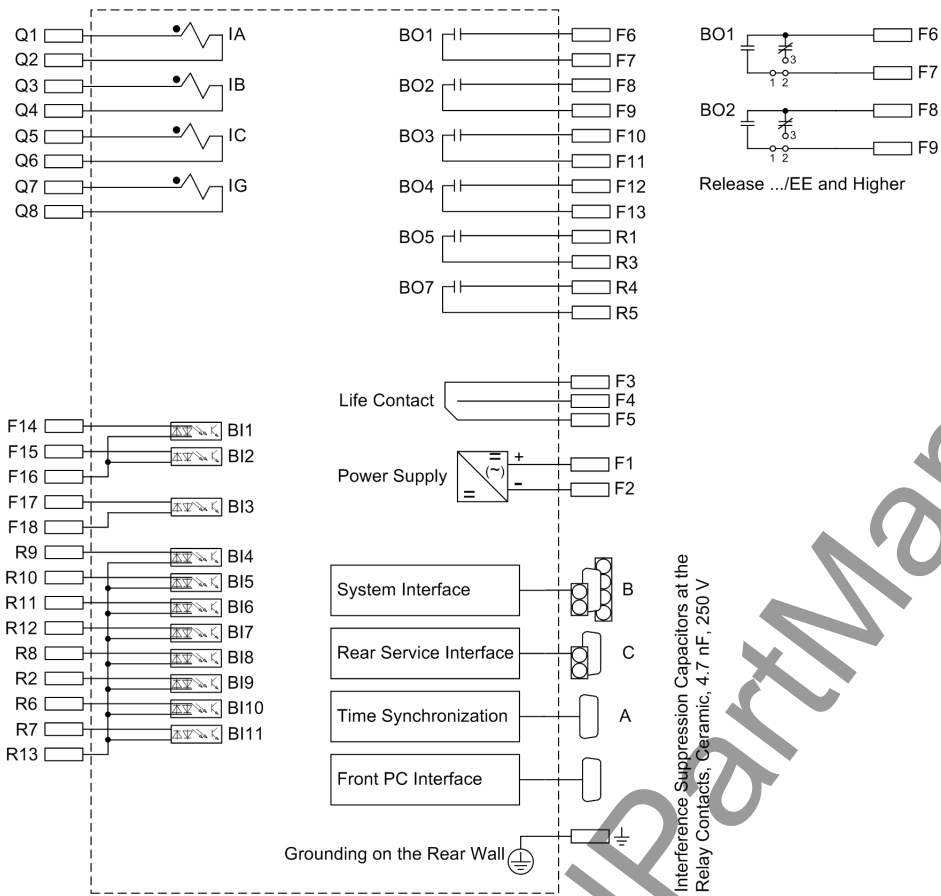

Figure A-3 Connection diagram for 7SJ612*-*D/E (panel flush mounted or cubicle mounted)

Double commands cannot be directly allocated to BO5 / BO7. If these outputs are used for issuing a double command, it has to be divided into two single commands via CFC.

A.2.2 Housing for Panel Surface Mounting

7SJ610*-*B

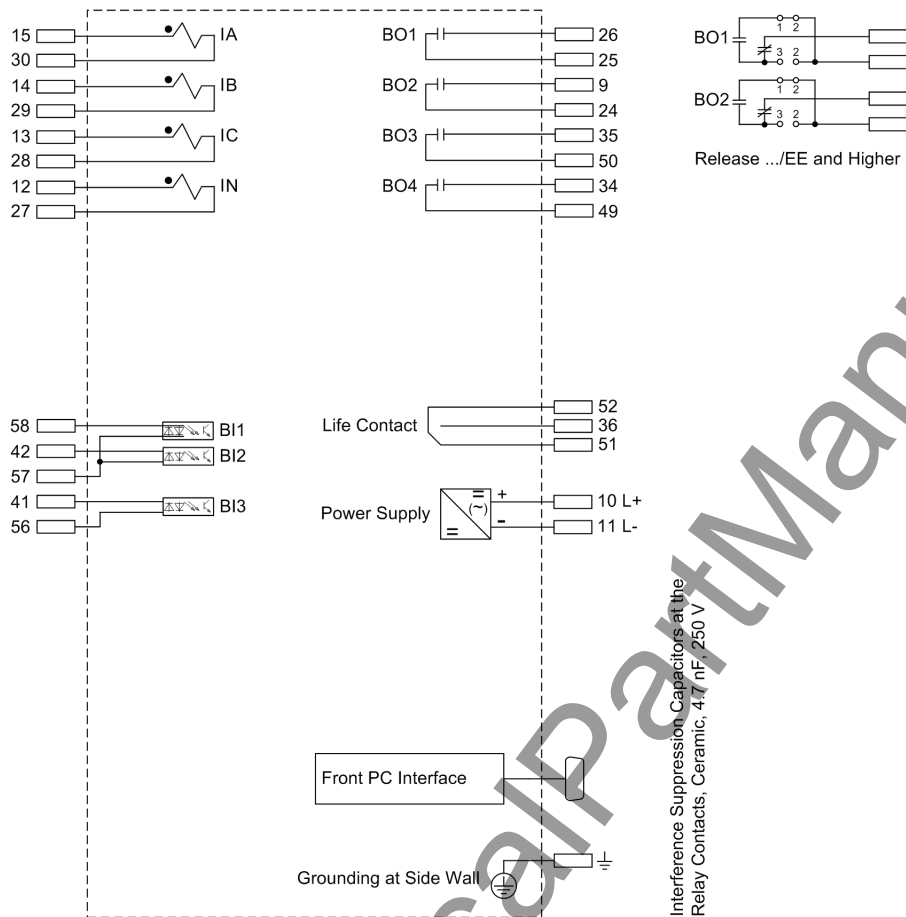

Figure A-4 Connection diagram for 7SJ610*-*B (panel surface mounted)

7SJ611*-*B

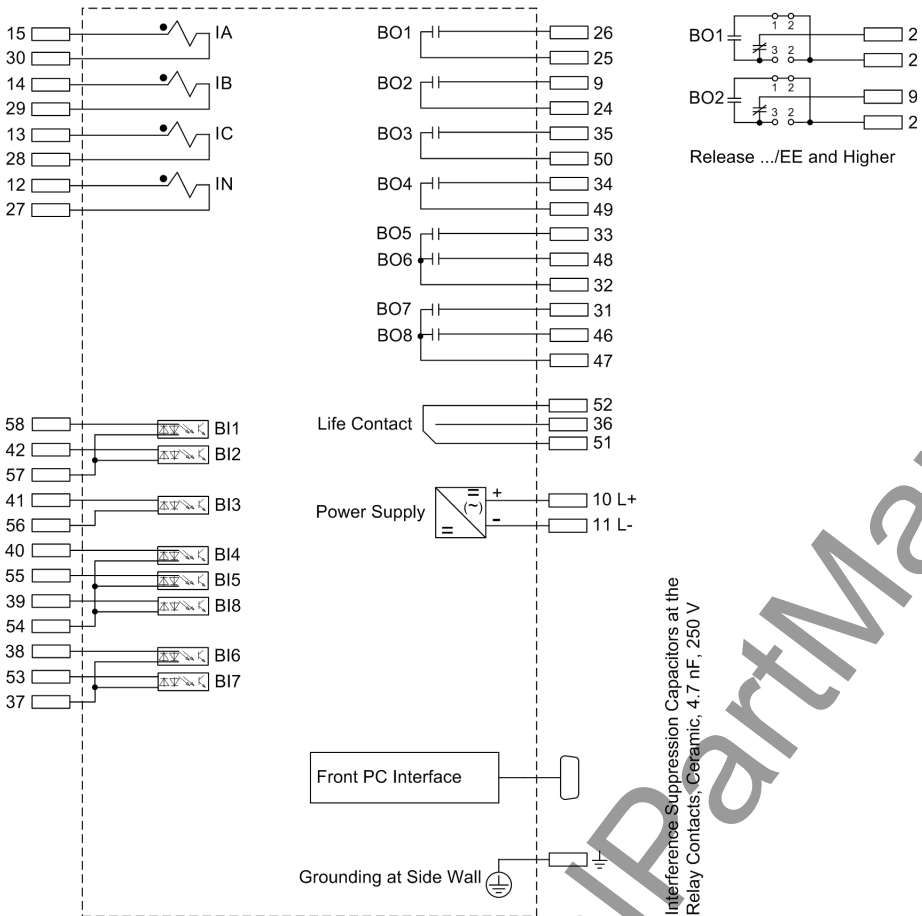

Figure A-5 Connection diagram for 7SJ611*-*B (panel surface mounted)

Interference Suppression Capacitors at the Relay Contacts, Ceramic, 4.7 nF, 250 V

7SJ612*-*B

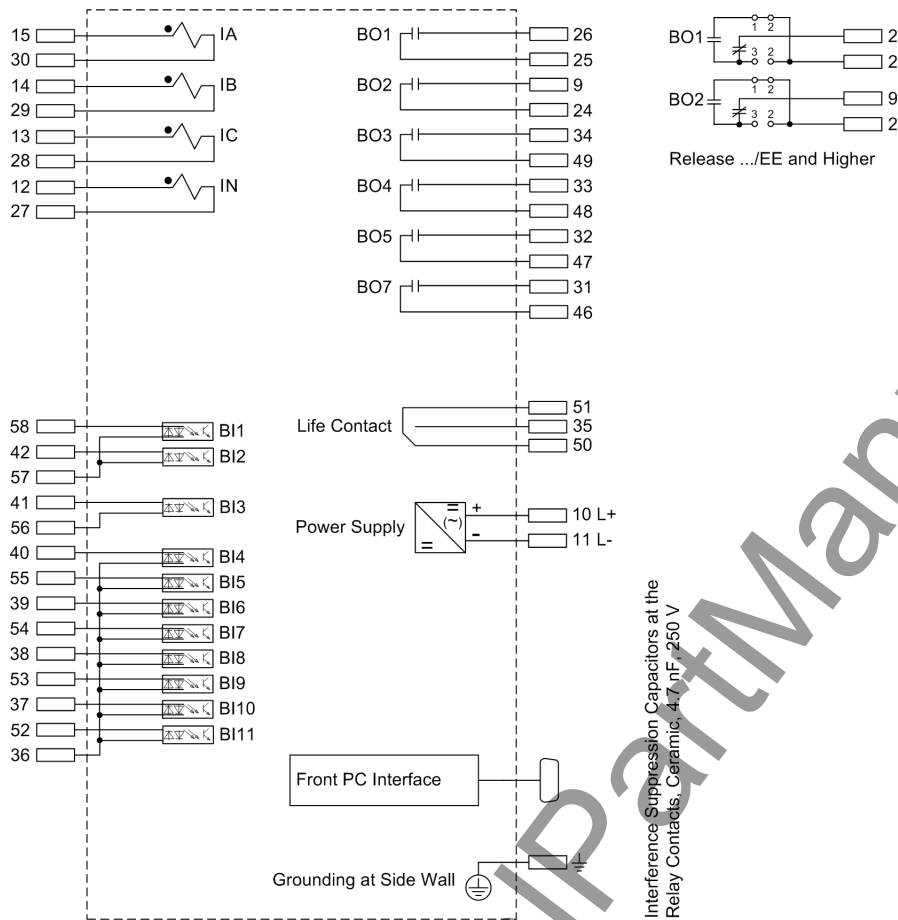

Figure A-6 Connection diagram for 7SJ612*-*B (panel surface mounted)

Double commands cannot be directly allocated to BO5 / BO7. If these outputs are used for issuing a double command, it has to be divided into two single commands via CFC.

A.2.3 Terminal Assignment on Housing for Panel Surface Mounting

7SJ610/1/2*-*B (up to release /CC)

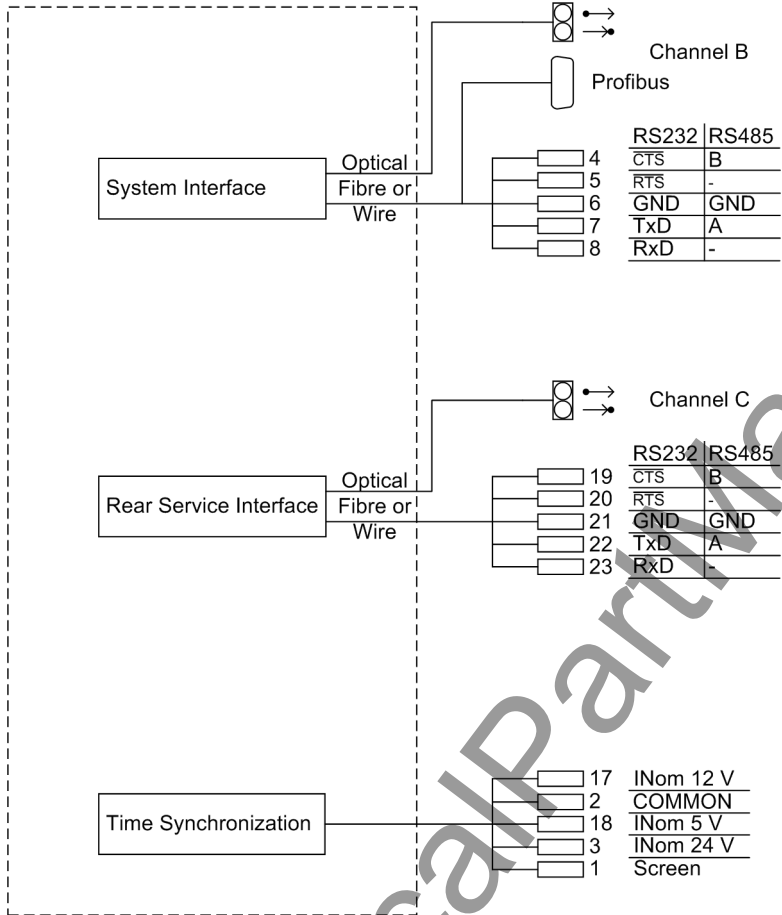

Figure A-7 Connection diagram for 7SJ610/1/2*-*B up to release ... /CC (panel surface mounted)

7SJ610/1/2*-*B (up to release /DD)

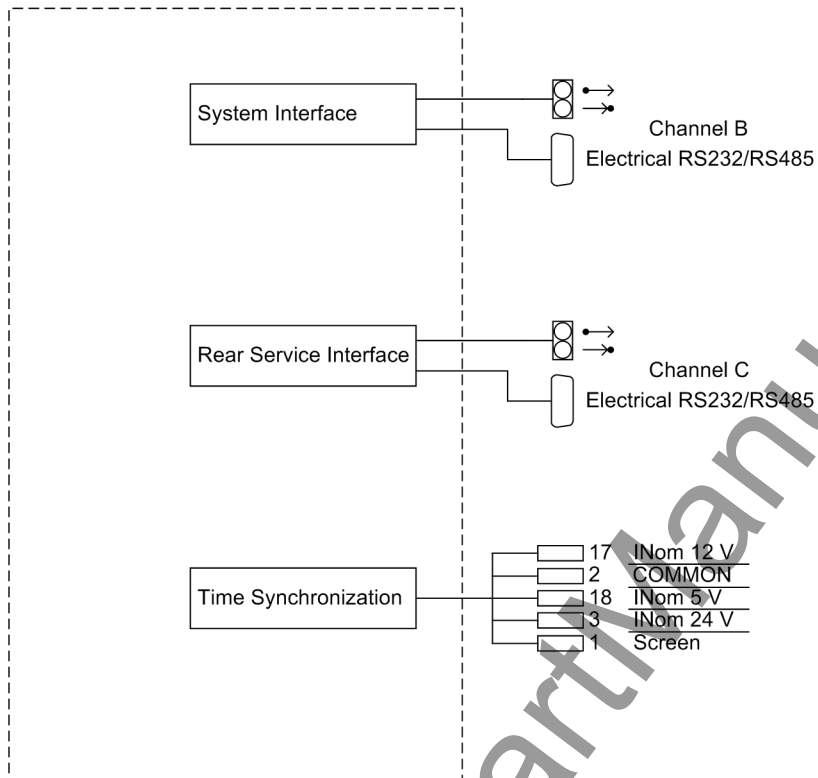

Figure A-8 Connection diagram for 7SJ610/1/2*-*B, release ... /DD and higher (panel surface mounted)

A.2.4 Connector Assignment

On the Interfaces

	RS232	RS485	Profibus FMS Slave, RS485 Profibus DP Slave, RS485	Modbus, RS485 DNP3.0, RS485	Ethernet RS232	IEC 60870-5-103 redundant RS485 (RJ45)
1	Shield (electrically connected with shield end)				Tx+	B/B' (RxD/TxD-P)
2	RxD	—	—	—	Tx-	A/A' (RxD/TxD-N)
3	TxD	A/A' (RxD/TxD-N)	B/B' (RxD/TxD-P)	A	Rx+	—
4	—	—	CNTR-A (TTL)	RTS (TTL level)	—	—
5	GND	C/C' (GND)	C/C' (GND)	GND1	—	—
6	—	—	+5 V (max. load <100 mA)	VCC1	Rx-	—
7	RTS	—*)	—	—	—	—
8	CTS	B/B' (RxD/TxD-P)	A/A' (RxD/TxD-N)	B	—	—
9	—	—	—	—	—	—

*) Pin 7 also carries the RTS signal with RS232 level when operated as RS485 interface.
Pin 7 must therefore not be connected!

On the Time Synchronization Interface

Pin no.	Designation	Signal Meaning
1	P24_TSIG	Input 24 V
2	P5_TSIG	Input 5 V
3	M_TSIG	Return Line
4	—*)	—*)
5	Screen	Screen Potential
6	—	—
7	P12_TSIG	Input 12 V
8	P_TSYNC*)	Input 24 V*)
9	Screen	Screen Potential

*) assigned, but not available

A.3 Connection Examples

A.3.1 Connection Examples for Current Transformers, all Devices

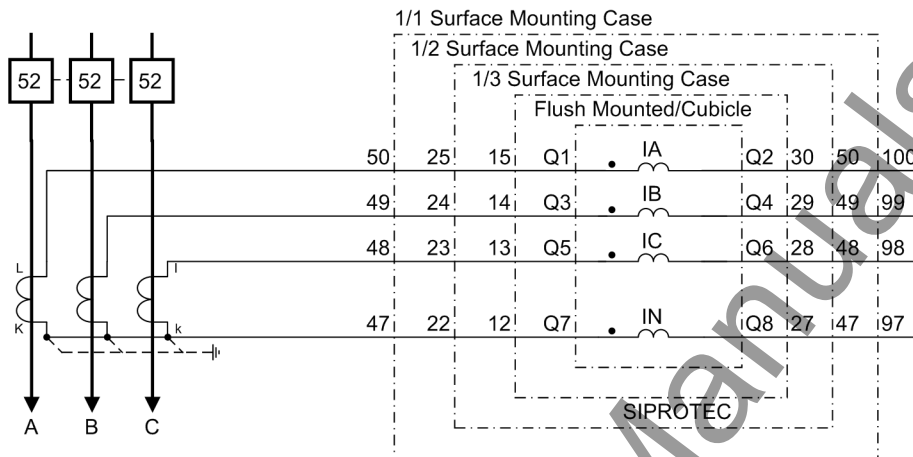

Figure A-9 Current connections to three current transformers with a starpoint connection for ground current (residual $3I_0$ neutral current), normal circuit layout

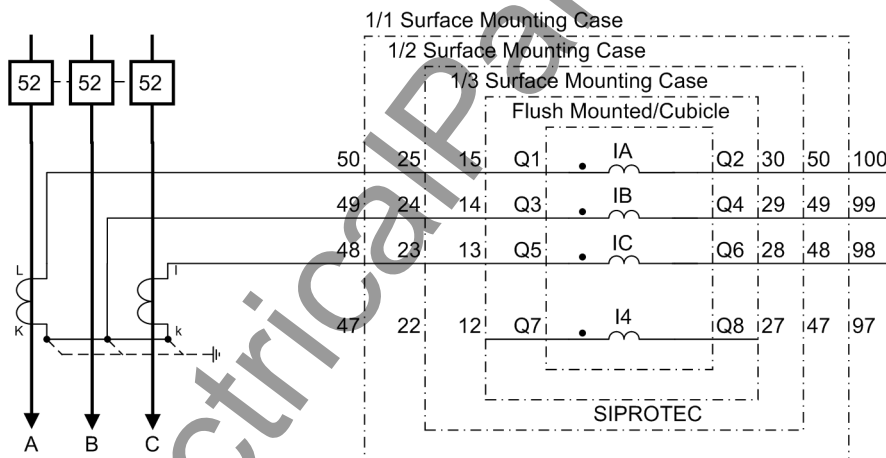

Figure A-10 Current connections to two current transformers - only for ungrounded or compensated networks

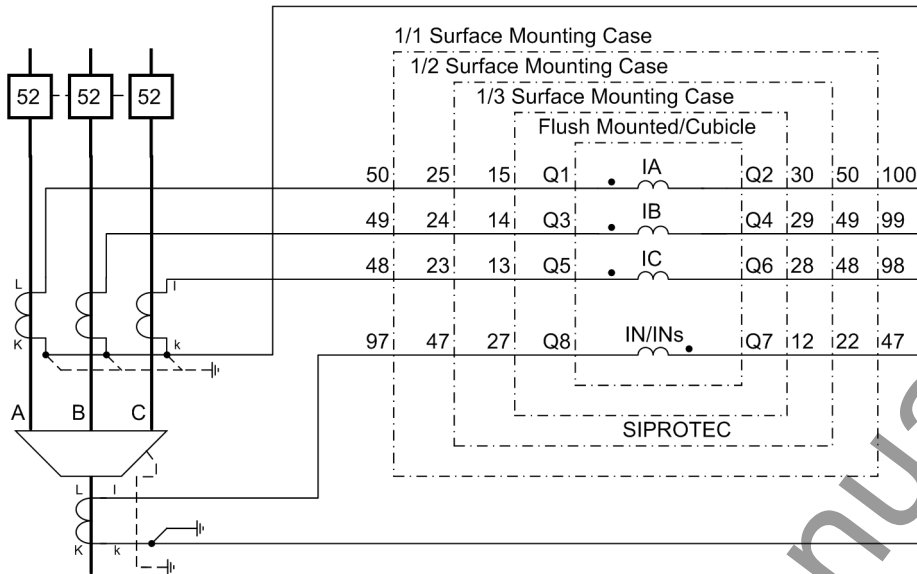

Figure A-11 Current connections to three current transformers, ground current from additional summation CT, normal circuit layout

Important! Grounding of the cable shield must be effected at the cable's side

For busbar-side grounding of the current transformer, the current polarity of the device is changed via address 0201. This also reverses the polarity of current input IN/INs. When using a cable-type current transformer, the connection of k and l at Q8 and Q7 must be changed.

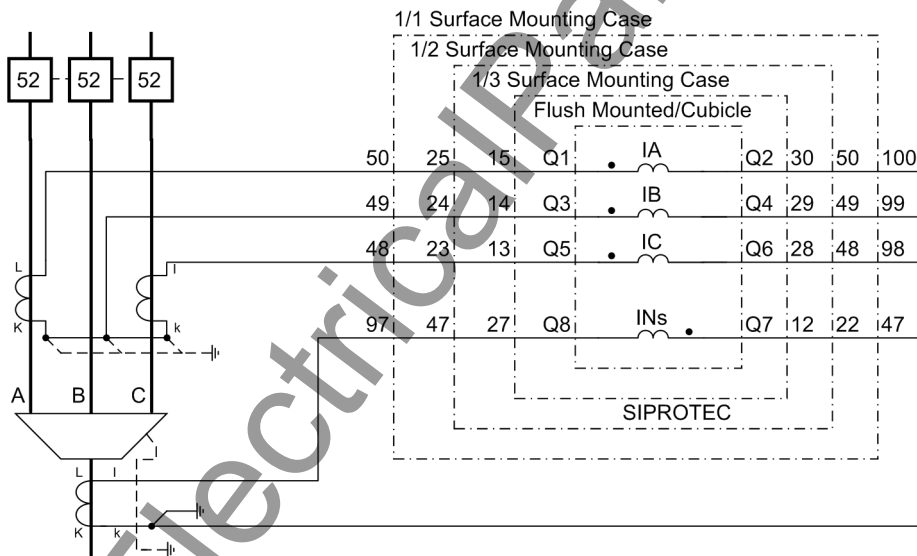

Figure A-12 Current connections to two current transformers, ground current of additional toroidal transformer for sensitive ground fault detection.

Important! Grounding of the cable shield must be effected at the cable's side

For busbar-side grounding of the current transformer, the current polarity of the device is changed via address 0201. This also reverses the polarity of current input INs. When using a cable-type current transformer, the connection of k and l at Q8 and Q7 must be changed.

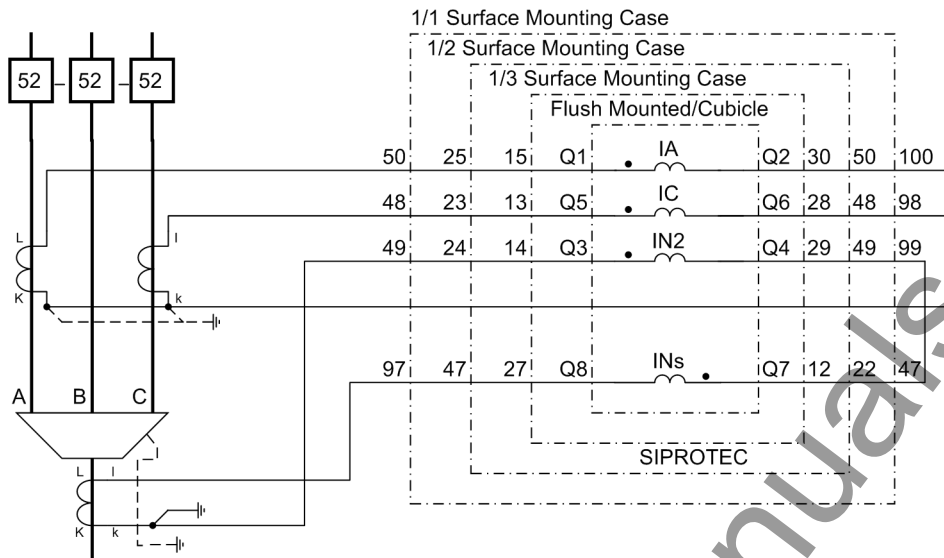

Figure A-13 Current transformer connections to two phase-current transformers and a ground-current transformer; the ground current is taken via the highly sensitive and sensitive ground input.

Important! Grounding of the cable shield must be effected at the cable's side

For busbar-side grounding of the current transformer, the current polarity of the device is changed via address 0201. This also reverses the polarity of current input INs. When using a cable-type current transformer, the connection of k and I at Q8 and Q7 must be changed.

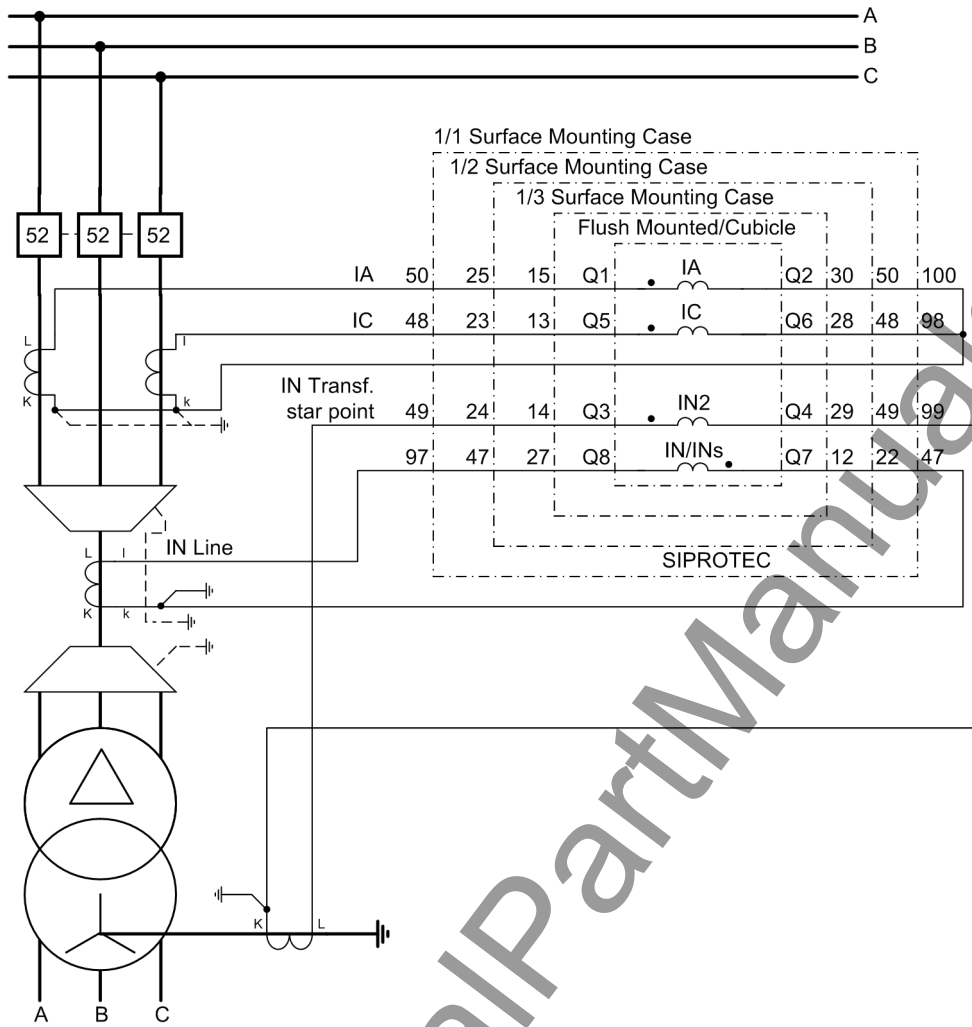

Figure A-14 Current transformer connections to two phase currents and two ground currents;
IN/INs – ground current of the line, IG2 – ground current of the transformer starpoint

Important! Grounding of the cable shield must be effected at the cable's side

For busbar-side grounding of the current transformer, the current polarity of the device is changed via address 0201. This also reverses the polarity of current input IN/INs. When using a cable-type current transformer, the connection of k and l at Q8 and Q7 must be changed.

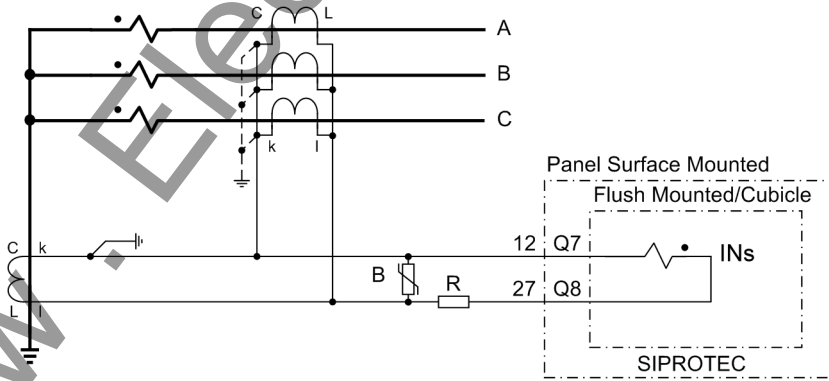

Figure A-15 High-impedance differential protection for a grounded transformer winding (showing the partial connection for the high-impedance differential protection)

A.3.2 Connection Examples for RTD-Box, all Devices

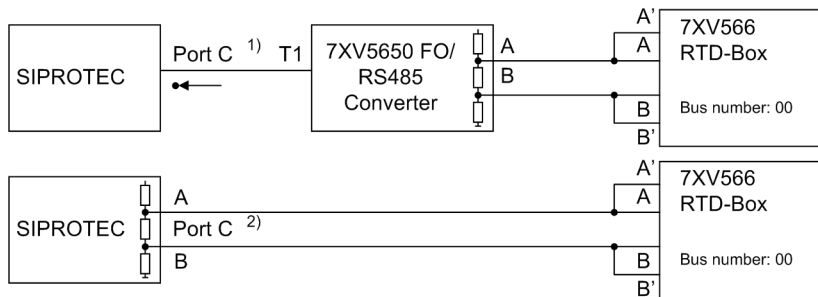

Figure A-16 Simplex operation with one RTD-Box, above: optical design (1 FO); below: design with RS 485

- 1) for 7SJ64 port D
- 2) for 7SJ64 optionally port C or port D

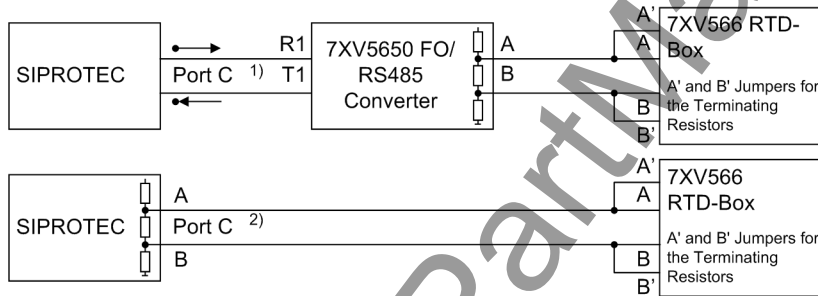

Figure A-17 Half-duplex operation with one RTD-Box, above: optical design (2 FOs); below: design with RS 485

- 1) for 7SJ64 port D
- 2) for 7SJ64 optionally port C or port D

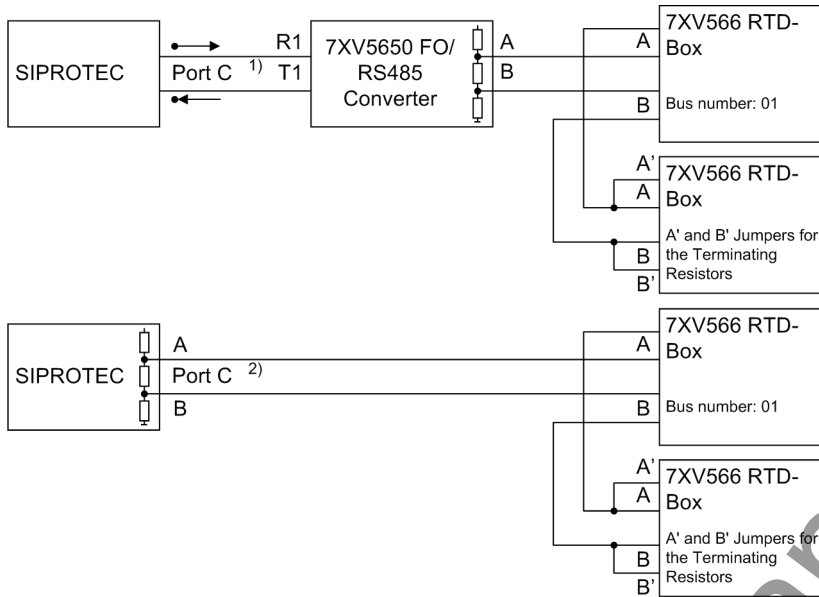

Figure A-18 Half-duplex operation with two RTD-Boxes, above: optical design (2 FOs); below: design with RS 485

1) for 7SJ64 port D
2) for 7SJ64 optionally port C or port D

A.4 Current Transformer Requirements

The requirements for phase current transformers are usually determined by the overcurrent time protection, particularly by the high-current element settings. Besides, there is a minimum requirement based on experience.

The recommendations are given according to the standard IEC 60044-1.

The standards IEC 60044-6, BS 3938 and ANSI/IEEE C 57.13 are referred to for converting the requirement into the knee-point voltage and other transformer classes.

A.4.1 Accuracy limiting factors

Effective and Rated Accuracy Limiting Factor

Required minimum effective accuracy limiting factor	$K_{ALF} = \frac{50 \cdot 2_{PU}}{I_{pNom}}$	
	but at least 20	
	with	
	K_{ALF}	Minimum effective accuracy limiting factor
	$50 \cdot 2_{PU}$	Primary pickup value of the high-current element
	I_{pNom}	Primary nominal transformer current
Resulting rated accuracy limiting factor	$K_{ALF} = \frac{R_{BC} + R_{Ct}}{R_{BN} + R_{Ct}} \cdot K_{ALF}$	
	with	
	K_{ALF}	Rated accuracy limiting factor
	R_{BC}	Connected burden resistance (device and cables)
	R_{BN}	Nominal burden resistance
	R_{Ct}	Transformer internal burden resistance

Calculation example according to IEC 60044-1

$I_{sNom} = 1 \text{ A}$ $K_{ALF} = 20$ $R_{BC} = 0.6 \Omega$ (device and cables) $R_{Ct} = 3 \Omega$ $R_{BN} = 5 \Omega$ (5 VA)	$K_{ALF} = \frac{0.6 + 3}{5 + 3} \cdot 20 = 9$ K_{ALF} set to 10, so that: 5P10, 5 VA
with	
I_{sNom} = secondary transformer nominal current	

A.4.2 Class conversion

Table A-1 Conversion into other classes

British Standard BS 3938	$V_k = \frac{(R_{Ct} + R_{BN}) \cdot I_{sNom} \cdot K_{ALF}}{1,3}$	
ANSI/IEEE C 57.13, class C	$V_{stmax} = 20 \cdot I_{sNom} \cdot R_{BN} \cdot \frac{K_{ALF}}{20}$ $I_{sNom} = 5 \text{ A (typical value)}$	
IEC 60044-6 (transient response), class TPS	$V_{al} = K \cdot k_{SSC} \cdot (R_{Ct} + R_{BN}) \cdot I_{sNom}$ $K \approx 1$ $K_{SSC} \approx K_{ALF}$	
Classes TPX, TPY, TPZ	Calculation See Chapter A.4.1 Accuracy limiting factors with: $K_{SSC} \approx n$ T_P depending on power system and specified closing sequence	
	with	
	V_k	Knee-point voltage
	R_{Ct}	Internal burden resistance
	R_{BN}	Nominal burden resistance
	I_{sNom}	secondary nominal transformer current
	K_{ALF}	Rated accuracy limiting factor
	$V_{s.t.max}$	sec. terminal volt. at $20 I_{pNom}$
	V_{al}	sec. magnetization limit voltage
	K	Dimensioning factor
	K_{SSC}	Factor symmetr. Rated fault current
	T_P	Primary time constant

A.4.3 Cable core balance current transformer

General

The requirements to the cable core balance current transformer are determined by the function „sensitive ground fault detection“.

The recommendations are given according to the standard IEC 60044-1.

Requirements

Transformation ratio, typical It may be necessary to select a different transformation ratio to suit the specific power system and thus the amount of the maximum ground fault current.	60 / 1
Accuracy limiting factor	FS = 10
Minimum power	1.2 VA
Maximum connected load – For secondary current threshold values ≥ 20 mA – For secondary current threshold values < 20 mA	≤ 1.2 VA ($\leq 1.2 \Omega$) ≤ 0.4 VA ($\leq 0.4 \Omega$)

Class accuracy

Table A-2 Minimum required class accuracy depending on neutral grounding and function operating principle

Neutral	isolated	compensated	high-resistance grounded
	Class 3	Class 1	Class 3

For extremely small ground fault currents it may become necessary to correct the angle at the device (see function description of „sensitive ground fault detection“).

A.5 Default Settings

When the device leaves the factory, a large number of LED indications, binary inputs and outputs as well as function keys are already preset. They are summarised in the following table.

A.5.1 LEDs

Table A-3 Preset LED displays

LEDs	Default function	Function No.	Description
LED1	Relay TRIP	511	Relay GENERAL TRIP command
LED2	50/51 Ph A PU	1762	50/51 Phase A picked up
LED3	50/51 Ph B PU	1763	50/51 Phase B picked up
LED4	50/51 Ph C PU	1764	50/51 Phase C picked up
LED5	50N/51NPickedup	1765	50N/51N picked up
LED6	Failure Σ I	162	Failure: Current Summation
	Fail I balance	163	Failure: Current Balance
	Fail Ph. Seq. I	175	Failure: Phase Sequence Current
LED7	Not configured	1	No Function configured

A.5.2 Binary Input

Table A-4 Binary input presettings for all devices and ordering variants

Binary Input	Default function	Function No.	Description
BI1	>BLOCK 50-2	1721	>BLOCK 50-2
	>BLOCK 50N-2	1724	>BLOCK 50N-2
BI2	>Reset LED	5	>Reset LED
BI3	>Light on		>Back Light on

Table A-5 Further binary input presettings for 7SJ611*- and 7SJ612*-

Binary Input	Default function	Function No.	Description
BI4	>52-b	4602	>52-b contact (OPEN, if bkr is closed)
	52Breaker		52 Breaker
BI5	>52-a	4601	>52-a contact (OPEN, if bkr is open)
	52Breaker		52 Breaker

A.5.3 Binary Output

Table A-6 Output Relay Presettings for All Devices and Ordering Variants

Binary Output	Default function	Function No.	Description
BO1	Relay TRIP 52Breaker	511	Relay GENERAL TRIP command 52 Breaker
BO2	52Breaker 79 Close	2851	52 Breaker 79 - Close command
BO3	52Breaker 79 Close	2851	52 Breaker 79 - Close command
BO4	Failure Σ I Fail I balance Fail Ph. Seq. I	162 163 175	Failure: Current Summation Failure: Current Balance Failure: Phase Sequence Current

Table A-7 Further Output Relay Presettings for 7SJ611**- , 7SJ612**-

Binary Output	Default function	Function No.	Description
BO7	Relay PICKUP	501	Relay PICKUP

A.5.4 Function Keys

Table A-8 Applies to All Devices and Ordered Variants

Function Keys	Default function
F1	Display of operational indications
F2	Display of the primary operational measured values
F3	Display of the last fault event recording
F4	Not preassigned

A.5.5 Default Display

In devices with 4-line displays and depending on the device version, a number of predefined measured value pages are available. The start page of the default display appearing after startup of the device can be selected in the device data via parameter 640 **Start image DD**.

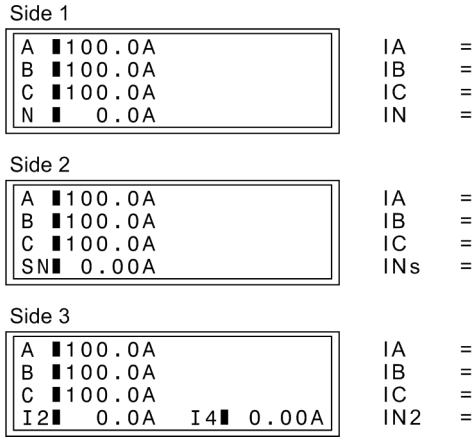

INs / IN =

Figure A-19 Default display of 7SJ61 for models without extended measured values (13th digit of MLFB = 1)

Page 3 of the default display can only be used if for the current connection (parameter 251 **CT Connect.**) one of the two special connection types (**A, G2, C, G; G->B** or **A, G2, C, G; G2->B**) was selected (see description of **Power System Data 1**).

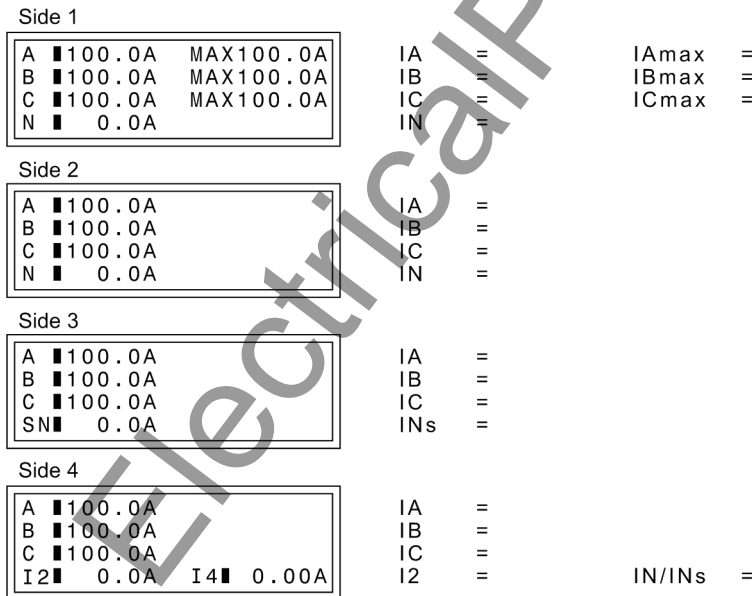

IN/INs =

Figure A-20 Default display of 7SJ61 for models with extended measured values (13th digit of MLFB = 3)

Page 4 of the default display can only be used if for the current connection (parameter 251 **CT Connect.**) one of the two special connection types (**A, G2, C, G; G->B** or **A, G2, C, G; G2->B**) were selected (see description of **Power System Data 1**).

Spontaneous Fault Indication

The spontaneous annunciations serve to display the most important data about a fault. They appear automatically in the display after general interrogation of the device, in the sequence shown in the following figure.

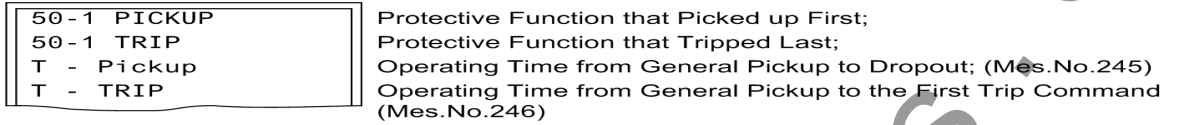

Figure A-21 Display of spontaneous messages in the HMI

A.5.6 Pre-defined CFC Charts

Some CFC Charts are already supplied with the SIPROTEC device.

Device and System Logic

The NEGATOR block assigns the input signal "DataStop" directly to an output. This is not directly possible without the interconnection of this block.

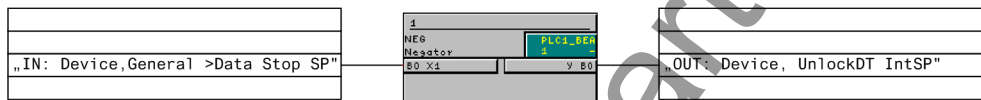

Figure A-22 Logical Link between Input and Output

Set points MV

Using modules on the running sequence "measured value processing", a low current monitor for the three phase currents is implemented. The output message is set high as soon as one of the three phase currents falls below the set threshold:

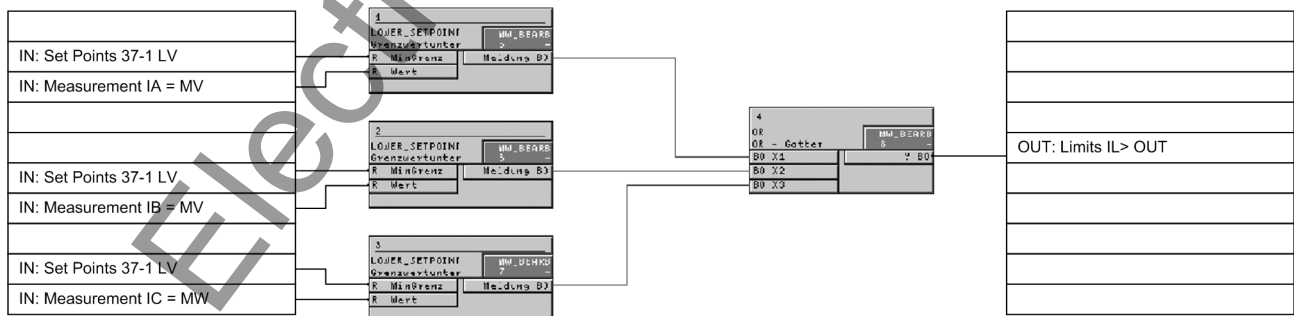

Figure A-23 Undercurrent monitoring

Using modules on the running sequence "measured value processing", an additional overcurrent monitor is implemented.

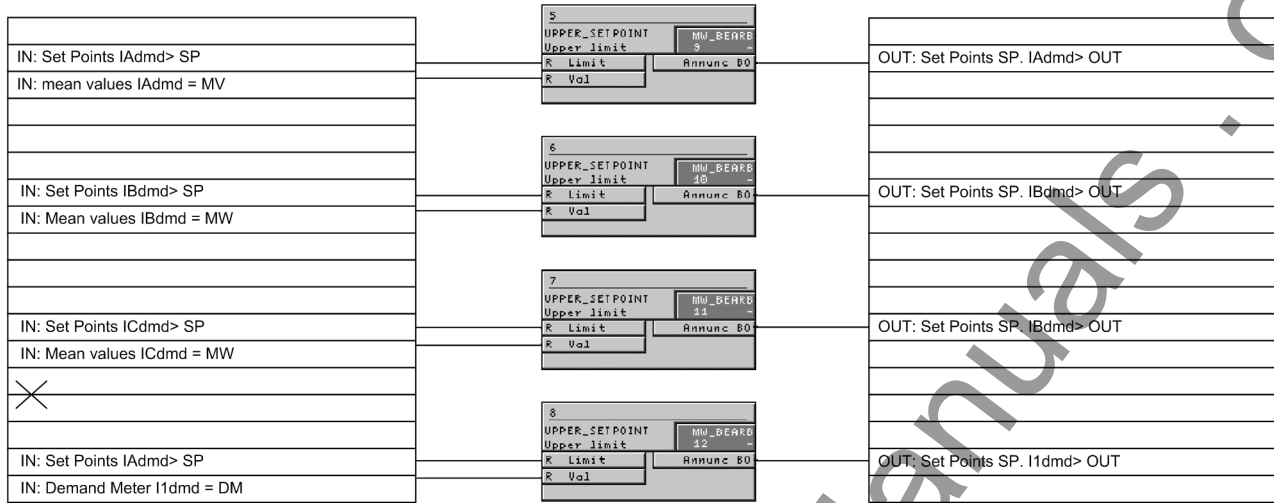

Figure A-24 Overcurrent monitoring

A.6 Protocol-dependent Functions

Protocol → Function ↓	IEC 60870-5-103, single	IEC 60870-5-103, redundant	IEC 61850 Ethernet (EN 100)	PROFIBUS DP	PROFIBUS FMS	DNP3.0 Modbus ASCII/RTU	Additional service interface (optional)
Operational Measured Values	Yes	Yes	Yes	Yes	Yes	Yes	Yes
Metered values	Yes	Yes	Yes	Yes	Yes	Yes	Yes
Fault Recording	Yes	Yes	Yes	No. Only via additional service interface	Yes	No. Only via additional service interface	Yes
Remote relay setting	No. Only via additional service interface	Yes	Yes	No. Only via additional service interface	Yes	No. Only via additional service interface	Yes
User-defined messages and switching objects	Yes	Yes	Yes	Yes	Yes	Yes	Yes
Time Synchronization	Yes	Yes	Yes	Yes	Yes	Yes	—
Messages with time stamp	Yes	Yes	Yes	Yes	Yes	Yes	Yes
Commissioning aids							
Measured value indication blocking	Yes	Yes	Yes	No	Yes	No	Yes
Creating test messages	Yes	Yes	Yes	No	Yes	No	Yes
Physical mode							
Physical mode	Asynchronous	Asynchronous	Synchronous	Asynchronous	Asynchronous	Asynchronous	—
Transmission Mode	cyclically/Event	cyclically/Event	cyclically/Event	Cyclically	cyclically/Event	cyclically/Event ^(DNP) Cyclically ^(Modbus)	—
Baud rate	1200 to 115200	2400 to 57600	Up to 100 MBaud	Up to 1.5 MBaud	Up to 1.5 MBaud	2400 to 19200	4800 to 115200
Type	– RS232 – RS485 – Fiber-optic cables	– RS485	Ethernet TP	– RS485 – Fiber-optic cables (double ring)	– RS485 – Fiber-optic cables (single ring, double ring)	– RS485 – Fiber-optic cables	– RS232 – RS485 – Fiber-optic cables

A.7 Functional Scope

Addr.	Parameter	Setting Options	Default Setting	Comments
103	Grp Chge OPTION	Disabled Enabled	Disabled	Setting Group Change Option
104	OSC. FAULT REC.	Disabled Enabled	Enabled	Oscillographic Fault Records
112	Charac. Phase	Disabled Definite Time TOC IEC TOC ANSI User Defined PU User def. Reset	Definite Time	50/51
113	Charac. Ground	Disabled Definite Time TOC IEC TOC ANSI User Defined PU User def. Reset	Definite Time	50N/51N
117	Coldload Pickup	Disabled Enabled	Disabled	Cold Load Pickup
122	InrushRestraint	Disabled Enabled	Disabled	2nd Harmonic Inrush Restraint
127	50 1Ph	Disabled Enabled	Disabled	50 1Ph
131	Sens. Gnd Fault	Disabled Definite Time User Defined PU Log. inverse A Log. Inverse B	Disabled	(sensitive) Ground fault
133	INTERM.EF	Disabled with Ignd with 3I0 with Ignd,sens.	Disabled	Intermittent earth fault protection
140	46	Disabled TOC ANSI TOC IEC Definite Time	Disabled	46 Negative Sequence Protection
141	48	Disabled Enabled	Disabled	48 Startup Supervision of Motors
142	49	Disabled No ambient temp With amb. temp.	Disabled	49 Thermal Overload Protection
143	66 #of Starts	Disabled Enabled	Disabled	66 Startup Counter for Motors
144	LOAD JAM PROT.	Disabled Enabled	Disabled	Load Jam Protection
170	50BF	Disabled Enabled enabled w/ 3I0>	Disabled	50BF Breaker Failure Protection
171	79 Auto Recl.	Disabled Enabled	Disabled	79 Auto-Reclose Function

Addr.	Parameter	Setting Options	Default Setting	Comments
172	52 B.WEAR MONIT	Disabled I _x -Method 2P-Method I _{2t} -Method	Disabled	52 Breaker Wear Monitoring
182	74 Trip Ct Supv	Disabled 2 Binary Inputs 1 Binary Input	Disabled	74TC Trip Circuit Supervision
190	RTD-BOX INPUT	Disabled Port C	Disabled	External Temperature Input
191	RTD CONNECTION	6 RTD simplex 6 RTD HDX 12 RTD HDX	6 RTD simplex	Ext. Temperature Input Connection Type
	FLEXIBLE FUNC. 1...20	Flex. Function 01 Flex. Function 02 Flex. Function 03 Flex. Function 04 Flex. Function 05 Flex. Function 06 Flex. Function 07 Flex. Function 08 Flex. Function 09 Flex. Function 10 Flex. Function 11 Flex. Function 12 Flex. Function 13 Flex. Function 14 Flex. Function 15 Flex. Function 16 Flex. Function 17 Flex. Function 18 Flex. Function 19 Flex. Function 20	Please select	Flexible Functions

A.8 Settings

Addresses which have an appended "A" can only be changed with DIGSI, under "Display Additional Settings".

The table indicates region-specific default settings. Column C (configuration) indicates the corresponding secondary nominal current of the current transformer.

Addr.	Parameter	Function	C	Setting Options	Default Setting	Comments
0	FLEXIBLE FUNC.	Flx		OFF ON Alarm Only	OFF	Flexible Function
0	OPERRAT. MODE	Flx		3-phase 1-phase no reference	3-phase	Mode of Operation
0	MEAS. QUANTITY	Flx		Please select Current Binary Input	Please select	Selection of Measured Quantity
0	MEAS. METHOD	Flx		Fundamental True RMS Positive seq. Negative seq. Zero sequence Ratio I2/I1	Fundamental	Selection of Measurement Method
0	PICKUP WITH	Flx		Exceeding Dropping below	Exceeding	Pickup with
0	CURRENT	Flx		Ia Ib Ic In In sensitive In2	Ia	Current
0	P.U. THRESHOLD	Flx	Pick up Threshold			
0	P.U. THRESHOLD	Flx	Pick up Threshold			
0	P.U. THRESHOLD	Flx		0.001 .. 1.500 A	0.100 A	Pickup Threshold
0	P.U. THRESHOLD	Flx		15 .. 100 %	20 %	Pickup Threshold
0	T TRIP DELAY	Flx		0.00 .. 3600.00 sec	1.00 sec	Trip Time Delay
0	T PICKUP DELAY	Flx		0.00 .. 60.00 sec	0.00 sec	Pickup Time Delay
0A	T DROPOUT DELAY	Flx		0.00 .. 60.00 sec	0.00 sec	Dropout Time Delay
0A	DROPOUT RATIO	Flx		0.70 .. 0.99	0.95	Dropout Ratio
0A	DROPOUT RATIO	Flx		1.01 .. 3.00	1.05	Dropout Ratio
201	CT Starpoint	P.System Data 1		towards Line towards Busbar	towards Line	CT Starpoint
204	CT PRIMARY	P.System Data 1		10 .. 50000 A	100 A	CT Rated Primary Current
205	CT SECONDARY	P.System Data 1		1A 5A	1A	CT Rated Secondary Current
209	PHASE SEQ.	P.System Data 1		A B C A C B	A B C	Phase Sequence
210A	TMin TRIP CMD	P.System Data 1		0.01 .. 32.00 sec	0.15 sec	Minimum TRIP Command Duration
211A	TMax CLOSE CMD	P.System Data 1		0.01 .. 32.00 sec	1.00 sec	Maximum Close Command Duration
212	BkrClosed I MIN	P.System Data 1	1A 5A	0.04 .. 1.00 A 0.20 .. 5.00 A	0.04 A 0.20 A	Closed Breaker Min. Current Threshold
214	Rated Frequency	P.System Data 1		50 Hz 60 Hz	50 Hz	Rated Frequency
217	Ignd-CT PRIM	P.System Data 1		1 .. 50000 A	60 A	Ignd-CT rated primary current
218	Ignd-CT SEC	P.System Data 1		1A 5A	1A	Ignd-CT rated secondary current

Addr.	Parameter	Function	C	Setting Options	Default Setting	Comments
235A	ATEX100	P.System Data 1		NO YES	NO	Storage of th. Replicas w/o Power Supply
238	Ignd2-CT PRIM	P.System Data 1		1 .. 50000 A	60 A	Ignd2-CT rated primary c. (conn. to I2)
250A	50/51 2-ph prot	P.System Data 1		ON OFF	OFF	50, 51 Time Overcurrent with 2ph. prot.
251A	CT Connect.	P.System Data 1		A, B, C, (Gnd) A,G2,C,G; G->B A,G2,C,G; G2->B	A, B, C, (Gnd)	CT Connection
260	Ir-52	P.System Data 1		10 .. 50000 A	125 A	Rated Normal Current (52 Breaker)
261	OP.CYCLES AT Ir	P.System Data 1		100 .. 1000000	10000	Switching Cycles at Rated Normal Current
262	Isc-52	P.System Data 1		10 .. 100000 A	25000 A	Rated Short-Circuit Breaking Current
263	OP.CYCLES Isc	P.System Data 1		1 .. 1000	50	Switch. Cycles at Rated Short-Cir. Curr.
264	Ix EXPONENT	P.System Data 1		1.0 .. 3.0	2.0	Exponent for the Ix-Method
265	Cmd.via control	P.System Data 1		(Setting options depend on configuration)	None	52 B.Wear: Open Cmd. via Control Device
266	T 52 BREAKTIME	P.System Data 1		1 .. 600 ms	80 ms	Breaktime (52 Breaker)
267	T 52 OPENING	P.System Data 1		1 .. 500 ms	65 ms	Opening Time (52 Breaker)
276	TEMP. UNIT	P.System Data 1		Celsius Fahrenheit	Celsius	Unit of temperature measurement
280	Holmgr. for Σi	P.System Data 1		NO YES	NO	Holmgreen-conn. (for fast sum-i-monit.)
302	CHANGE	Change Group		Group A Group B Group C Group D Binary Input Protocol	Group A	Change to Another Setting Group
401	WAVEFORMTRIGGER	Osc. Fault Rec.		Save w. Pickup Save w. TRIP Start w. TRIP	Save w. Pickup	Waveform Capture
402	WAVEFORM DATA	Osc. Fault Rec.		Fault event Pow.Sys.Flt.	Fault event	Scope of Waveform Data
403	MAX. LENGTH	Osc. Fault Rec.		0.30 .. 5.00 sec	2.00 sec	Max. length of a Waveform Capture Record
404	PRE. TRIG. TIME	Osc. Fault Rec.		0.05 .. 0.50 sec	0.25 sec	Captured Waveform Prior to Trigger
405	POST REC. TIME	Osc. Fault Rec.		0.05 .. 0.50 sec	0.10 sec	Captured Waveform after Event
406	BinIn CAPT.TIME	Osc. Fault Rec.		0.10 .. 5.00 sec; ∞	0.50 sec	Capture Time via Binary Input
610	FltDisp.LED/LCD	Device, General		Target on PU Target on TRIP	Target on PU	Fault Display on LED / LCD
613A	50N/51N/67N w.	P.System Data 1		Ignd (measured) 3I0 (calcul.)	Ignd (measured)	50N/51N/67N Ground Overcurrent with
640	Start image DD	Device, General		image 1 image 2 image 3 image 4	image 1	Start image Default Display
1102	FullScaleCurr.	P.System Data 2		10 .. 50000 A	100 A	Measur:FullScaleCurrent(Equipm.rating)
1107	I MOTOR START	P.System Data 2	1A	0.40 .. 10.00 A	2.50 A	Motor Start Current (Block 49, Start 48)
			5A	2.00 .. 50.00 A	12.50 A	
1201	FCT 50/51	50/51 Overcur.		ON OFF	ON	50, 51 Phase Time Overcurrent
1202	50-2 PICKUP	50/51 Overcur.	1A	0.10 .. 35.00 A; ∞	2.00 A	50-2 Pickup
			5A	0.50 .. 175.00 A; ∞	10.00 A	
1203	50-2 DELAY	50/51 Overcur.		0.00 .. 60.00 sec; ∞	0.00 sec	50-2 Time Delay
1204	50-1 PICKUP	50/51 Overcur.	1A	0.10 .. 35.00 A; ∞	1.00 A	50-1 Pickup
			5A	0.50 .. 175.00 A; ∞	5.00 A	
1205	50-1 DELAY	50/51 Overcur.		0.00 .. 60.00 sec; ∞	0.50 sec	50-1 Time Delay

Addr.	Parameter	Function	C	Setting Options	Default Setting	Comments
1207	51 PICKUP	50/51 Overcur.	1A	0.10 .. 4.00 A	1.00 A	51 Pickup
			5A	0.50 .. 20.00 A	5.00 A	
1208	51 TIME DIAL	50/51 Overcur.		0.05 .. 3.20 sec; ∞	0.50 sec	51 Time Dial
1209	51 TIME DIAL	50/51 Overcur.		0.50 .. 15.00 ; ∞	5.00	51 Time Dial
1210	51 Drop-out	50/51 Overcur.		Instantaneous Disk Emulation	Disk Emulation	Drop-out characteristic
1211	51 IEC CURVE	50/51 Overcur.		Normal Inverse Very Inverse Extremely Inv. Long Inverse	Normal Inverse	IEC Curve
1212	51 ANSI CURVE	50/51 Overcur.		Very Inverse Inverse Short Inverse Long Inverse Moderately Inv. Extremely Inv. Definite Inv.	Very Inverse	ANSI Curve
1213A	MANUAL CLOSE	50/51 Overcur.		50-3 instant. 50-2 instant. 50 -1 instant. 51 instant. Inactive	50-2 instant.	Manual Close Mode
1214A	50-2 active	50/51 Overcur.		Always with 79 active	Always	50-2 active
1215A	50 T DROP-OUT	50/51 Overcur.		0.00 .. 60.00 sec	0.00 sec	50 Drop-Out Time Delay
1216A	50-3 active	50/51 Overcur.		Always with 79 active	Always	50-3 active
1217	50-3 PICKUP	50/51 Overcur.	1A	1.00 .. 35.00 A; ∞	∞ A	50-3 Pickup
			5A	5.00 .. 175.00 A; ∞	∞ A	
1218	50-3 DELAY	50/51 Overcur.		0.00 .. 60.00 sec; ∞	0.00 sec	50-3 Time Delay
1219A	50-3 measurem.	50/51 Overcur.		Fundamental True RMS Instantaneous	Fundamental	50-3 measurement of
1220A	50-2 measurem.	50/51 Overcur.		Fundamental True RMS	Fundamental	50-2 measurement of
1221A	50-1 measurem.	50/51 Overcur.		Fundamental True RMS	Fundamental	50-1 measurement of
1222A	51 measurem.	50/51 Overcur.		Fundamental True RMS	Fundamental	51 measurement of
1230	51/51N	50/51 Overcur.		1.00 .. 20.00 I/lp; ∞ 0.01 .. 999.00 TD		51/51N
1231	MofPU Res T/Tp	50/51 Overcur.		0.05 .. 0.95 I/lp; ∞ 0.01 .. 999.00 TD		Multiple of Pickup <-> T/Tp
1301	FCT 50N/51N	50/51 Overcur.		ON OFF	ON	50N, 51N Ground Time Overcurrent
1302	50N-2 PICKUP	50/51 Overcur.	1A	0.05 .. 35.00 A; ∞	0.50 A	50N-2 Pickup
			5A	0.25 .. 175.00 A; ∞	2.50 A	
1303	50N-2 DELAY	50/51 Overcur.		0.00 .. 60.00 sec; ∞	0.10 sec	50N-2 Time Delay
1304	50N-1 PICKUP	50/51 Overcur.	1A	0.05 .. 35.00 A; ∞	0.20 A	50N-1 Pickup
			5A	0.25 .. 175.00 A; ∞	1.00 A	
1305	50N-1 DELAY	50/51 Overcur.		0.00 .. 60.00 sec; ∞	0.50 sec	50N-1 Time Delay
1307	51N PICKUP	50/51 Overcur.	1A	0.05 .. 4.00 A	0.20 A	51N Pickup
			5A	0.25 .. 20.00 A	1.00 A	
1308	51N TIME DIAL	50/51 Overcur.		0.05 .. 3.20 sec; ∞	0.20 sec	51N Time Dial
1309	51N TIME DIAL	50/51 Overcur.		0.50 .. 15.00 ; ∞	5.00	51N Time Dial
1310	51N Drop-out	50/51 Overcur.		Instantaneous Disk Emulation	Disk Emulation	Drop-Out Characteristic
1311	51N IEC CURVE	50/51 Overcur.		Normal Inverse Very Inverse Extremely Inv. Long Inverse	Normal Inverse	IEC Curve

Addr.	Parameter	Function	C	Setting Options	Default Setting	Comments
1312	51N ANSI CURVE	50/51 Overcur.		Very Inverse Inverse Short Inverse Long Inverse Moderately Inv. Extremely Inv. Definite Inv.	Very Inverse	ANSI Curve
1313A	MANUAL CLOSE	50/51 Overcur.		50N-3 instant. 50N-2 instant. 50N-1 instant. 51N instant. Inactive	50N-2 instant.	Manual Close Mode
1314A	50N-2 active	50/51 Overcur.		Always With 79 Active	Always	50N-2 active
1315A	50N T DROP-OUT	50/51 Overcur.		0.00 .. 60.00 sec	0.00 sec	50N Drop-Out Time Delay
1316A	50N-3 active	50/51 Overcur.		Always with 79 active	Always	50N-3 active
1317	50N-3 PICKUP	50/51 Overcur.		0.25 .. 35.00 A; ∞	∞ A	50N-3 Pickup
1318	50N-3 DELAY	50/51 Overcur.		0.00 .. 60.00 sec; ∞	0.00 sec	50N-3 Time Delay
1319A	50N-3 measurem.	50/51 Overcur.		Fundamental True RMS Instantaneous	Fundamental	50N-3 measurement of
1320A	50N-2 measurem.	50/51 Overcur.		Fundamental True RMS	Fundamental	50N-2 measurement of
1321A	50N-1 measurem.	50/51 Overcur.		Fundamental True RMS	Fundamental	50N-1 measurement of
1322A	51N measurem.	50/51 Overcur.		Fundamental True RMS	Fundamental	51N measurement of
1330	50N/51N	50/51 Overcur.		1.00 .. 20.00 I/p; ∞ 0.01 .. 999.00 TD		50N/51N
1331	MofPU Res T/TEp	50/51 Overcur.		0.05 .. 0.95 I/p; ∞ 0.01 .. 999.00 TD		Multiple of Pickup <-> T/TEp
1701	COLDLOAD PICKUP	ColdLoadPickup		OFF ON	OFF	Cold-Load-Pickup Function
1702	Start Condition	ColdLoadPickup		No Current Breaker Contact 79 ready	No Current	Start Condition
1703	CB Open Time	ColdLoadPickup		0 .. 21600 sec	3600 sec	Circuit Breaker OPEN Time
1704	Active Time	ColdLoadPickup		1 .. 21600 sec	3600 sec	Active Time
1705	Stop Time	ColdLoadPickup		1 .. 600 sec; ∞	600 sec	Stop Time
1801	50c-2 PICKUP	ColdLoadPickup	1A	0.10 .. 35.00 A; ∞	10.00 A	50c-2 Pickup
			5A	0.50 .. 175.00 A; ∞	50.00 A	
1802	50c-2 DELAY	ColdLoadPickup		0.00 .. 60.00 sec; ∞	0.00 sec	50c-2 Time Delay
1803	50c-1 PICKUP	ColdLoadPickup	1A	0.10 .. 35.00 A; ∞	2.00 A	50c-1 Pickup
			5A	0.50 .. 175.00 A; ∞	10.00 A	
1804	50c-1 DELAY	ColdLoadPickup		0.00 .. 60.00 sec; ∞	0.30 sec	50c-1 Time Delay
1805	51c PICKUP	ColdLoadPickup	1A	0.10 .. 4.00 A	1.50 A	51c Pickup
			5A	0.50 .. 20.00 A	7.50 A	
1806	51c TIME DIAL	ColdLoadPickup		0.05 .. 3.20 sec; ∞	0.50 sec	51c Time dial
1807	51c TIME DIAL	ColdLoadPickup		0.50 .. 15.00 ; ∞	5.00	51c Time dial
1808	50c-3 PICKUP	ColdLoadPickup	1A	1.00 .. 35.00 A; ∞	∞ A	50c-3 Pickup
			5A	5.00 .. 175.00 A; ∞	∞ A	
1809	50c-3 DELAY	ColdLoadPickup		0.00 .. 60.00 sec; ∞	0.00 sec	50c-3 Time Delay
1901	50Nc-2 PICKUP	ColdLoadPickup	1A	0.05 .. 35.00 A; ∞	7.00 A	50Nc-2 Pickup
			5A	0.25 .. 175.00 A; ∞	35.00 A	
1902	50Nc-2 DELAY	ColdLoadPickup		0.00 .. 60.00 sec; ∞	0.00 sec	50Nc-2 Time Delay
1903	50Nc-1 PICKUP	ColdLoadPickup	1A	0.05 .. 35.00 A; ∞	1.50 A	50Nc-1 Pickup
			5A	0.25 .. 175.00 A; ∞	7.50 A	
1904	50Nc-1 DELAY	ColdLoadPickup		0.00 .. 60.00 sec; ∞	0.30 sec	50Nc-1 Time Delay
1905	51Nc PICKUP	ColdLoadPickup	1A	0.05 .. 4.00 A	1.00 A	51Nc Pickup
			5A	0.25 .. 20.00 A	5.00 A	
1906	51Nc T-DIAL	ColdLoadPickup		0.05 .. 3.20 sec; ∞	0.50 sec	51Nc Time Dial

Addr.	Parameter	Function	C	Setting Options	Default Setting	Comments
1907	51Nc T-DIAL	ColdLoadPickup		0.50 .. 15.00 ; ∞	5.00	51Nc Time Dial
1908	50Nc-3 PICKUP	ColdLoadPickup		0.25 .. 35.00 A; ∞	∞ A	50Nc-3 Pickup
1909	50Nc-3 DELAY	ColdLoadPickup		0.00 .. 60.00 sec; ∞	0.00 sec	50Nc-3 Time Delay
2201	INRUSH REST.	50/51 Overcur.		OFF ON	OFF	Inrush Restraint
2202	2nd HARMONIC	50/51 Overcur.		10 .. 45 %	15 %	2nd. harmonic in % of fundamental
2203	CROSS BLOCK	50/51 Overcur.		NO YES	NO	Cross Block
2204	CROSS BLK TIMER	50/51 Overcur.		0.00 .. 180.00 sec	0.00 sec	Cross Block Time
2205	I Max	50/51 Overcur.	1A	0.30 .. 25.00 A	7.50 A	Maximum Current for Inrush Restraint
			5A	1.50 .. 125.00 A	37.50 A	
2701	50 1Ph	50 1Ph		OFF ON	OFF	50 1Ph
2702	50 1Ph-2 PICKUP	50 1Ph	1A	0.05 .. 35.00 A; ∞	0.50 A	50 1Ph-2 Pickup
			5A	0.25 .. 175.00 A; ∞	2.50 A	
2703	50 1Ph-2 PICKUP	50 1Ph		0.003 .. 1.500 A; ∞	0.300 A	50 1Ph-2 Pickup
2704	50 1Ph-2 DELAY	50 1Ph		0.00 .. 60.00 sec; ∞	0.10 sec	50 1Ph-2 Time Delay
2705	50 1Ph-1 PICKUP	50 1Ph	1A	0.05 .. 35.00 A; ∞	0.20 A	50 1Ph-1 Pickup
			5A	0.25 .. 175.00 A; ∞	1.00 A	
2706	50 1Ph-1 PICKUP	50 1Ph		0.003 .. 1.500 A; ∞	0.100 A	50 1Ph-1 Pickup
2707	50 1Ph-1 DELAY	50 1Ph		0.00 .. 60.00 sec; ∞	0.50 sec	50 1Ph-1 Time Delay
3101	Sens. Gnd Fault	Sens. Gnd Fault		OFF ON	OFF	(Sensitive) Ground Fault
3113	50Ns-2 PICKUP	Sens. Gnd Fault		0.001 .. 1.500 A	0.300 A	50Ns-2 Pickup
3113	50Ns-2 PICKUP	Sens. Gnd Fault	1A	0.05 .. 35.00 A	10.00 A	50Ns-2 Pickup
			5A	0.25 .. 175.00 A	50.00 A	
3114	50Ns-2 DELAY	Sens. Gnd Fault		0.00 .. 320.00 sec; ∞	1.00 sec	50Ns-2 Time Delay
3117	50Ns-1 PICKUP	Sens. Gnd Fault		0.001 .. 1.500 A	0.100 A	50Ns-1 Pickup
3117	50Ns-1 PICKUP	Sens. Gnd Fault	1A	0.05 .. 35.00 A	2.00 A	50Ns-1 Pickup
			5A	0.25 .. 175.00 A	10.00 A	
3118	50Ns-1 DELAY	Sens. Gnd Fault		0.00 .. 320.00 sec; ∞	2.00 sec	50Ns-1 Time delay
3119	51Ns PICKUP	Sens. Gnd Fault		0.001 .. 1.400 A	0.100 A	51Ns Pickup
3119	51Ns PICKUP	Sens. Gnd Fault		0.003 .. 0.500 A	0.004 A	51Ns Pickup
3119	51Ns PICKUP	Sens. Gnd Fault	1A	0.05 .. 4.00 A	1.00 A	51Ns Pickup
			5A	0.25 .. 20.00 A	5.00 A	
3120	51NsTIME DIAL	Sens. Gnd Fault		0.10 .. 4.00 sec; ∞	1.00 sec	51Ns Time Dial
3121A	50Ns T DROP-OUT	Sens. Gnd Fault		0.00 .. 60.00 sec	0.00 sec	50Ns Drop-Out Time Delay
3127	51Ns I T min	Sens. Gnd Fault		0.003 .. 1.400 A	1.333 A	51Ns Current at const. Time Delay T min
3127	51Ns I T min	Sens. Gnd Fault	1A	0.05 .. 20.00 A	15.00 A	51Ns Current at const. Time Delay T min
			5A	0.25 .. 100.00 A	75.00 A	
3128	51Ns I T knee	Sens. Gnd Fault		0.003 .. 0.650 A	0.040 A	51Ns Current at Knee Point
3128	51Ns I T knee	Sens. Gnd Fault	1A	0.05 .. 17.00 A	5.00 A	51Ns Current at Knee Point
			5A	0.25 .. 85.00 A	25.00 A	
3129	51Ns T knee	Sens. Gnd Fault		0.20 .. 100.00 sec	23.60 sec	51Ns Time Delay at Knee Point
3131	M.of PU TD	Sens. Gnd Fault		1.00 .. 20.00 MofPU; ∞ 0.01 .. 999.00 TD		Multiples of PU Time-Dial
3132	51Ns TD	Sens. Gnd Fault		0.05 .. 1.50	0.20	51Ns Time Dial
3140	51Ns Tmin	Sens. Gnd Fault		0.00 .. 30.00 sec	1.20 sec	51Ns Minimum Time Delay
3140	51Ns T min	Sens. Gnd Fault		0.10 .. 30.00 sec	0.80 sec	51Ns Minimum Time Delay
3141	51Ns Tmax	Sens. Gnd Fault		0.00 .. 30.00 sec	5.80 sec	51Ns Maximum Time Delay
3141	51Ns T max	Sens. Gnd Fault		0.50 .. 200.00 sec	93.00 sec	51Ns Maximum Time Delay (at 51Ns PU)
3142	51Ns TIME DIAL	Sens. Gnd Fault		0.05 .. 15.00 sec; ∞	1.35 sec	51Ns Time Dial
3143	51Ns Startpoint	Sens. Gnd Fault		1.0 .. 4.0	1.1	51Ns Start Point of Inverse Charac.

Addr.	Parameter	Function	C	Setting Options	Default Setting	Comments
3301	INTERM.EF	Intermit. EF		OFF ON	OFF	Intermittent earth fault protection
3302	lie>	Intermit. EF	1A	0.05 .. 35.00 A	1.00 A	Pick-up value of interm. E/F stage
			5A	0.25 .. 175.00 A	5.00 A	
3302	lie>	Intermit. EF	1A	0.05 .. 35.00 A	1.00 A	Pick-up value of interm. E/F stage
			5A	0.25 .. 175.00 A	5.00 A	
3302	lie>	Intermit. EF		0.005 .. 1.500 A	1.000 A	Pick-up value of interm. E/F stage
3303	T-det.ext.	Intermit. EF		0.00 .. 10.00 sec	0.10 sec	Detection extension time
3304	T-sum det.	Intermit. EF		0.00 .. 100.00 sec	20.00 sec	Sum of detection times
3305	T-reset	Intermit. EF		1 .. 600 sec	300 sec	Reset time
3306	Nos.det.	Intermit. EF		2 .. 10	3	No. of det. for start of int. E/F prot
4001	FCT 46	46 Negative Seq		OFF ON	OFF	46 Negative Sequence Protection
4002	46-1 PICKUP	46 Negative Seq	1A	0.10 .. 3.00 A	0.10 A	46-1 Pickup
			5A	0.50 .. 15.00 A	0.50 A	
4003	46-1 DELAY	46 Negative Seq		0.00 .. 60.00 sec; ∞	1.50 sec	46-1 Time Delay
4004	46-2 PICKUP	46 Negative Seq	1A	0.10 .. 3.00 A	0.50 A	46-2 Pickup
			5A	0.50 .. 15.00 A	2.50 A	
4005	46-2 DELAY	46 Negative Seq		0.00 .. 60.00 sec; ∞	1.50 sec	46-2 Time Delay
4006	46 IEC CURVE	46 Negative Seq		Normal Inverse Very Inverse Extremely Inv.	Extremely Inv.	46 IEC Curve
4007	46 ANSI CURVE	46 Negative Seq		Extremely Inv. Inverse Moderately Inv. Very Inverse	Extremely Inv.	46 ANSI Curve
4008	46-TOC PICKUP	46 Negative Seq	1A	0.10 .. 2.00 A	0.90 A	46-TOC Pickup
			5A	0.50 .. 10.00 A	4.50 A	
4009	46-TOC TIMEDIAL	46 Negative Seq		0.50 .. 15.00 sec; ∞	5.00	46-TOC Time Dial
4010	46-TOC TIMEDIAL	46 Negative Seq		0.05 .. 3.20 sec; ∞	0.50 sec	46-TOC Time Dial
4011	46-TOC RESET	46 Negative Seq		Instantaneous Disk Emulation	Instantaneous	46-TOC Drop Out
4012A	46 T DROP-OUT	46 Negative Seq		0.00 .. 60.00 sec	0.00 sec	46 Drop-Out Time Delay
4101	FCT 48/66	48/66 Motorprot		OFF ON	OFF	48 / 66 Motor (Startup Monitor/Counter)
4102	STARTUP CURRENT	48/66 Motorprot	1A	0.50 .. 16.00 A	5.00 A	Startup Current
			5A	2.50 .. 80.00 A	25.00 A	
4103	STARTUP TIME	48/66 Motorprot		1.0 .. 180.0 sec	10.0 sec	Startup Time
4104	LOCK ROTOR TIME	48/66 Motorprot		0.5 .. 180.0 sec; ∞	2.0 sec	Permissible Locked Rotor Time
4105	STARTUP T WARM	48/66 Motorprot		0.5 .. 180.0 sec; ∞	10.0 sec	Startup Time for warm motor
4106	TEMP.COLD MOTOR	48/66 Motorprot		0 .. 80 %; ∞	25 %	Temperature limit for cold motor
4201	FCT 49	49 Th.Overload		OFF ON Alarm Only	OFF	49 Thermal overload protection
4202	49 K-FACTOR	49 Th.Overload		0.10 .. 4.00	1.10	49 K-Factor
4203	TIME CONSTANT	49 Th.Overload		1.0 .. 999.9 min	100.0 min	Time Constant
4204	49 ⊖ ALARM	49 Th.Overload		50 .. 100 %	90 %	49 Thermal Alarm Stage
4205	I ALARM	49 Th.Overload	1A	0.10 .. 4.00 A	1.00 A	Current Overload Alarm Setpoint
			5A	0.50 .. 20.00 A	5.00 A	
4207A	K _t -FACTOR	49 Th.Overload		1.0 .. 10.0	1.0	K _t -FACTOR when motor stops
4208A	T EMERGENCY	49 Th.Overload		10 .. 15000 sec	100 sec	Emergency time
4209	49 TEMP. RISE I	49 Th.Overload		40 .. 200 °C	100 °C	49 Temperature rise at rated sec. curr.
4210	49 TEMP. RISE I	49 Th.Overload		104 .. 392 °F	212 °F	49 Temperature rise at rated sec. curr.
4301	FCT 66	48/66 Motorprot		OFF ON	OFF	66 Startup Counter for Motors
4302	IStart/IMOTnom	48/66 Motorprot		1.10 .. 10.00	4.90	I Start / I Motor nominal

Addr.	Parameter	Function	C	Setting Options	Default Setting	Comments
4303	T START MAX	48/66 Motorprot		1 .. 320 sec	10 sec	Maximum Permissible Starting Time
4304	T Equal	48/66 Motorprot		0.0 .. 320.0 min	1.0 min	Temperature Equalization Time
4305	I MOTOR NOMINAL	48/66 Motorprot	1A	0.20 .. 1.20 A	1.00 A	Rated Motor Current
			5A	1.00 .. 6.00 A	5.00 A	
4306	MAX.WARM STARTS	48/66 Motorprot		1 .. 4	2	Maximum Number of Warm Starts
4307	#COLD-#WARM	48/66 Motorprot		1 .. 2	1	Number of Cold Starts - Warm Starts
4308	K _τ at STOP	48/66 Motorprot		0.2 .. 100.0	5.0	Extension of Time Constant at Stop
4309	K _τ at RUNNING	48/66 Motorprot		0.2 .. 100.0	2.0	Extension of Time Constant at Running
4310	T MIN. INHIBIT	48/66 Motorprot		0.2 .. 120.0 min	6.0 min	Minimum Restart Inhibit Time
4311	ROTOR OVERLOAD	48/66 Motorprot		ON OFF Alarm Only	ON	Rotor Overload Protection
4401	Load Jam Prot.	48/66 Motorprot		OFF ON Alarm Only	OFF	Load Jam Protection
4402	Load Jam I>	48/66 Motorprot	1A	0.50 .. 12.00 A	2.00 A	Load Jam Tripping Threshold
			5A	2.50 .. 60.00 A	10.00 A	
4403	TRIP DELAY	48/66 Motorprot		0.00 .. 600.00 sec	1.00 sec	Load Jam Trip Delay
4404	I Alarm	48/66 Motorprot	1A	0.50 .. 12.00 A	1.80 A	Load Jam Alarm Threshold
			5A	2.50 .. 60.00 A	9.00 A	
4405	ALARM DELAY	48/66 Motorprot		0.00 .. 600.00 sec	1.00 sec	Load Jam Alarm Delay
4406	T Start Blk.	48/66 Motorprot		0.00 .. 600.00 sec	10.00 sec	Load Jam Blocking after motor start
7001	FCT 50BF	50BF BkrFailure		OFF ON	OFF	50BF Breaker Failure Protection
7004	Chk BRK CONTACT	50BF BkrFailure		OFF ON	OFF	Check Breaker contacts
7005	TRIP-Timer	50BF BkrFailure		0.06 .. 60.00 sec; ∞	0.25 sec	TRIP-Timer
7006	50BF PICKUP	50BF BkrFailure	1A	0.05 .. 20.00 A	0.10 A	50BF Pickup current threshold
			5A	0.25 .. 100.00 A	0.50 A	
7007	50BF PICKUP IE>	50BF BkrFailure	1A	0.05 .. 20.00 A	0.10 A	50BF Pickup earth current threshold
			5A	0.25 .. 100.00 A	0.50 A	
7101	FCT 79	79M Auto Recl.		OFF ON	OFF	79 Auto-Reclose Function
7103	BLOCK MC Dur.	79M Auto Recl.		0.50 .. 320.00 sec; 0	1.00 sec	AR blocking duration after manual close
7105	TIME RESTRAINT	79M Auto Recl.		0.50 .. 320.00 sec	3.00 sec	79 Auto Reclosing reset time
7108	SAFETY 79 ready	79M Auto Recl.		0.01 .. 320.00 sec	0.50 sec	Safety Time until 79 is ready
7113	CHECK CB?	79M Auto Recl.		No check Chk each cycle	No check	Check circuit breaker before AR?
7114	T-Start MONITOR	79M Auto Recl.		0.01 .. 320.00 sec; ∞	0.50 sec	AR start-signal monitoring time
7115	CB TIME OUT	79M Auto Recl.		0.10 .. 320.00 sec	3.00 sec	Circuit Breaker (CB) Supervision Time
7116	Max. DEAD EXT.	79M Auto Recl.		0.50 .. 1800.00 sec; ∞	100.00 sec	Maximum dead time extension
7117	T-ACTION	79M Auto Recl.		0.01 .. 320.00 sec; ∞	∞ sec	Action time
7118	T DEAD DELAY	79M Auto Recl.		0.0 .. 1800.0 sec; ∞	1.0 sec	Maximum Time Delay of Dead-Time Start
7127	DEADTIME 1: PH	79M Auto Recl.		0.01 .. 320.00 sec	0.50 sec	Dead Time 1: Phase Fault
7128	DEADTIME 1: G	79M Auto Recl.		0.01 .. 320.00 sec	0.50 sec	Dead Time 1: Ground Fault
7129	DEADTIME 2: PH	79M Auto Recl.		0.01 .. 320.00 sec	0.50 sec	Dead Time 2: Phase Fault
7130	DEADTIME 2: G	79M Auto Recl.		0.01 .. 320.00 sec	0.50 sec	Dead Time 2: Ground Fault
7131	DEADTIME 3: PH	79M Auto Recl.		0.01 .. 320.00 sec	0.50 sec	Dead Time 3: Phase Fault
7132	DEADTIME 3: G	79M Auto Recl.		0.01 .. 320.00 sec	0.50 sec	Dead Time 3: Ground Fault
7133	DEADTIME 4: PH	79M Auto Recl.		0.01 .. 320.00 sec	0.50 sec	Dead Time 4: Phase Fault
7134	DEADTIME 4: G	79M Auto Recl.		0.01 .. 320.00 sec	0.50 sec	Dead Time 4: Ground Fault

Addr.	Parameter	Function	C	Setting Options	Default Setting	Comments
7135	# OF RECL. GND	79M Auto Recl.		0 .. 9	1	Number of Reclosing Cycles Ground
7136	# OF RECL. PH	79M Auto Recl.		0 .. 9	1	Number of Reclosing Cycles Phase
7137	Cmd.via control	79M Auto Recl.		(Setting options depend on configuration)	None	Close command via control device
7139	External SYNC	79M Auto Recl.		YES NO	NO	External 25 synchronisation
7140	ZONE SEQ.COORD.	79M Auto Recl.		OFF ON	OFF	ZSC - Zone sequence coordination
7150	50-1	79M Auto Recl.		No influence Starts 79 Stops 79	No influence	50-1
7151	50N-1	79M Auto Recl.		No influence Starts 79 Stops 79	No influence	50N-1
7152	50-2	79M Auto Recl.		No influence Starts 79 Stops 79	No influence	50-2
7153	50N-2	79M Auto Recl.		No influence Starts 79 Stops 79	No influence	50N-2
7154	51	79M Auto Recl.		No influence Starts 79 Stops 79	No influence	51
7155	51N	79M Auto Recl.		No influence Starts 79 Stops 79	No influence	51N
7162	sens Ground Flt	79M Auto Recl.		No influence Starts 79 Stops 79	No influence	(Sensitive) Ground Fault
7163	46	79M Auto Recl.		No influence Starts 79 Stops 79	No influence	46
7164	BINARY INPUT	79M Auto Recl.		No influence Starts 79 Stops 79	No influence	Binary Input
7165	3Pol.PICKUP BLK	79M Auto Recl.		YES NO	NO	3 Pole Pickup blocks 79
7166	50-3	79M Auto Recl.		No influence Starts 79 Stops 79	No influence	50-3
7167	50N-3	79M Auto Recl.		No influence Starts 79 Stops 79	No influence	50N-3
7200	bef.1.Cy:50-1	79M Auto Recl.		Set value T=T instant. T=0 blocked T= ∞	Set value T=T	before 1. Cycle: 50-1
7201	bef.1.Cy:50N-1	79M Auto Recl.		Set value T=T instant. T=0 blocked T= ∞	Set value T=T	before 1. Cycle: 50N-1
7202	bef.1.Cy:50-2	79M Auto Recl.		Set value T=T instant. T=0 blocked T= ∞	Set value T=T	before 1. Cycle: 50-2
7203	bef.1.Cy:50N-2	79M Auto Recl.		Set value T=T instant. T=0 blocked T= ∞	Set value T=T	before 1. Cycle: 50N-2
7204	bef.1.Cy:51	79M Auto Recl.		Set value T=T instant. T=0 blocked T= ∞	Set value T=T	before 1. Cycle: 51
7205	bef.1.Cy:51N	79M Auto Recl.		Set value T=T instant. T=0 blocked T= ∞	Set value T=T	before 1. Cycle: 51N
7212	bef.2.Cy:50-1	79M Auto Recl.		Set value T=T instant. T=0 blocked T= ∞	Set value T=T	before 2. Cycle: 50-1
7213	bef.2.Cy:50N-1	79M Auto Recl.		Set value T=T instant. T=0 blocked T= ∞	Set value T=T	before 2. Cycle: 50N-1

Addr.	Parameter	Function	C	Setting Options	Default Setting	Comments
7214	bef.2.Cy:50-2	79M Auto Recl.		Set value T=T instant. T=0 blocked T=∞	Set value T=T	before 2. Cycle: 50-2
7215	bef.2.Cy:50N-2	79M Auto Recl.		Set value T=T instant. T=0 blocked T=∞	Set value T=T	before 2. Cycle: 50N-2
7216	bef.2.Cy:51	79M Auto Recl.		Set value T=T instant. T=0 blocked T=∞	Set value T=T	before 2. Cycle: 51
7217	bef.2.Cy:51N	79M Auto Recl.		Set value T=T instant. T=0 blocked T=∞	Set value T=T	before 2. Cycle: 51N
7224	bef.3.Cy:50-1	79M Auto Recl.		Set value T=T instant. T=0 blocked T=∞	Set value T=T	before 3. Cycle: 50-1
7225	bef.3.Cy:50N-1	79M Auto Recl.		Set value T=T instant. T=0 blocked T=∞	Set value T=T	before 3. Cycle: 50N-1
7226	bef.3.Cy:50-2	79M Auto Recl.		Set value T=T instant. T=0 blocked T=∞	Set value T=T	before 3. Cycle: 50-2
7227	bef.3.Cy:50N-2	79M Auto Recl.		Set value T=T instant. T=0 blocked T=∞	Set value T=T	before 3. Cycle: 50N-2
7228	bef.3.Cy:51	79M Auto Recl.		Set value T=T instant. T=0 blocked T=∞	Set value T=T	before 3. Cycle: 51
7229	bef.3.Cy:51N	79M Auto Recl.		Set value T=T instant. T=0 blocked T=∞	Set value T=T	before 3. Cycle: 51N
7236	bef.4.Cy:50-1	79M Auto Recl.		Set value T=T instant. T=0 blocked T=∞	Set value T=T	before 4. Cycle: 50-1
7237	bef.4.Cy:50N-1	79M Auto Recl.		Set value T=T instant. T=0 blocked T=∞	Set value T=T	before 4. Cycle: 50N-1
7238	bef.4.Cy:50-2	79M Auto Recl.		Set value T=T instant. T=0 blocked T=∞	Set value T=T	before 4. Cycle: 50-2
7239	bef.4.Cy:50N-2	79M Auto Recl.		Set value T=T instant. T=0 blocked T=∞	Set value T=T	before 4. Cycle: 50N-2
7240	bef.4.Cy:51	79M Auto Recl.		Set value T=T instant. T=0 blocked T=∞	Set value T=T	before 4. Cycle: 51
7241	bef.4.Cy:51N	79M Auto Recl.		Set value T=T instant. T=0 blocked T=∞	Set value T=T	before 4. Cycle: 51N
7248	bef.1.Cy:50-3	79M Auto Recl.		Set value T=T instant. T=0 blocked T=∞	Set value T=T	before 1. Cycle: 50-3
7249	bef.1.Cy:50N-3	79M Auto Recl.		Set value T=T instant. T=0 blocked T=∞	Set value T=T	before 1. Cycle: 50N-3
7250	bef.2.Cy:50-3	79M Auto Recl.		Set value T=T instant. T=0 blocked T=∞	Set value T=T	before 2. Cycle: 50-3
7251	bef.2.Cy:50N-3	79M Auto Recl.		Set value T=T instant. T=0 blocked T=∞	Set value T=T	before 2. Cycle: 50N-3
7252	bef.3.Cy:50-3	79M Auto Recl.		Set value T=T instant. T=0 blocked T=∞	Set value T=T	before 3. Cycle: 50-3
7253	bef.3.Cy:50N-3	79M Auto Recl.		Set value T=T instant. T=0 blocked T=∞	Set value T=T	before 3. Cycle: 50N-3
7254	bef.4.Cy:50-3	79M Auto Recl.		Set value T=T instant. T=0 blocked T=∞	Set value T=T	before 4. Cycle: 50-3

Addr.	Parameter	Function	C	Setting Options	Default Setting	Comments
7255	bef.4.Cy:50N-3	79M Auto Recl.		Set value T=T instant. T=0 blocked T=∞	Set value T=T	before 4. Cycle: 50N-3
8101	MEASURE. SUPERV	Measur em.Superv		OFF ON	ON	Measurement Supervision
8104	BALANCE I LIMIT	Measur em.Superv	1A 5A	0.10 .. 1.00 A 0.50 .. 5.00 A	0.50 A 2.50 A	Current Threshold for Balance Monitoring
8105	BAL. FACTOR I	Measur em.Superv		0.10 .. 0.90	0.50	Balance Factor for Current Monitor
8106	Σ I THRESHOLD	Measur em.Superv	1A 5A	0.05 .. 2.00 A; ∞ 0.25 .. 10.00 A; ∞	0.10 A 0.50 A	Summated Current Monitoring Threshold
8107	Σ I FACTOR	Measur em.Superv		0.00 .. 0.95	0.10	Summated Current Monitoring Factor
8109	FAST Σ i MONIT	Measur em.Superv		OFF ON	ON	Fast Summated Current Monitoring
8201	FCT 74TC	74TC TripCirc.		ON OFF	ON	74TC TRIP Circuit Supervision
8202	Alarm Delay	74TC TripCirc.		1 .. 30 sec	2 sec	Delay Time for alarm
8301	DMD Interval	Demand meter		15 Min., 1 Sub 15 Min., 3 Subs 15 Min., 15 Subs 30 Min., 1 Sub 60 Min., 1 Sub 60 Min., 10 Subs 5 Min., 5 Subs	60 Min., 1 Sub	Demand Calculation Intervals
8302	DMD Sync.Time	Demand meter		On The Hour 15 After Hour 30 After Hour 45 After Hour	On The Hour	Demand Synchronization Time
8311	MinMax cycRESET	Min/Max meter		NO YES	YES	Automatic Cyclic Reset Function
8312	MiMa RESET TIME	Min/Max meter		0 .. 1439 min	0 min	MinMax Reset Timer
8313	MiMa RESETCYCLE	Min/Max meter		1 .. 365 Days	7 Days	MinMax Reset Cycle Period
8314	MinMaxRES.START	Min/Max meter		1 .. 365 Days	1 Days	MinMax Start Reset Cycle in
8315	MeterResolution	Energy		Standard Factor 10 Factor 100	Standard	Meter resolution
9011A	RTD 1 TYPE	RTD-Box		Not connected Pt 100 Ω Ni 120 Ω Ni 100 Ω	Pt 100 Ω	RTD 1: Type
9012A	RTD 1 LOCATION	RTD-Box		Oil Ambient Winding Bearing Other	Oil	RTD 1: Location
9013	RTD 1 STAGE 1	RTD-Box		-50 .. 250 °C; ∞	100 °C	RTD 1: Temperature Stage 1 Pickup
9014	RTD 1 STAGE 1	RTD-Box		-58 .. 482 °F; ∞	212 °F	RTD 1: Temperature Stage 1 Pickup
9015	RTD 1 STAGE 2	RTD-Box		-50 .. 250 °C; ∞	120 °C	RTD 1: Temperature Stage 2 Pickup
9016	RTD 1 STAGE 2	RTD-Box		-58 .. 482 °F; ∞	248 °F	RTD 1: Temperature Stage 2 Pickup
9021A	RTD 2 TYPE	RTD-Box		Not connected Pt 100 Ω Ni 120 Ω Ni 100 Ω	Not connected	RTD 2: Type
9022A	RTD 2 LOCATION	RTD-Box		Oil Ambient Winding Bearing Other	Other	RTD 2: Location
9023	RTD 2 STAGE 1	RTD-Box		-50 .. 250 °C; ∞	100 °C	RTD 2: Temperature Stage 1 Pickup
9024	RTD 2 STAGE 1	RTD-Box		-58 .. 482 °F; ∞	212 °F	RTD 2: Temperature Stage 1 Pickup

Addr.	Parameter	Function	C	Setting Options	Default Setting	Comments
9025	RTD 2 STAGE 2	RTD-Box		-50 .. 250 °C; ∞	120 °C	RTD 2: Temperature Stage 2 Pickup
9026	RTD 2 STAGE 2	RTD-Box		-58 .. 482 °F; ∞	248 °F	RTD 2: Temperature Stage 2 Pickup
9031A	RTD 3 TYPE	RTD-Box		Not connected Pt 100 Ω Ni 120 Ω Ni 100 Ω	Not connected	RTD 3: Type
9032A	RTD 3 LOCATION	RTD-Box		Oil Ambient Winding Bearing Other	Other	RTD 3: Location
9033	RTD 3 STAGE 1	RTD-Box		-50 .. 250 °C; ∞	100 °C	RTD 3: Temperature Stage 1 Pickup
9034	RTD 3 STAGE 1	RTD-Box		-58 .. 482 °F; ∞	212 °F	RTD 3: Temperature Stage 1 Pickup
9035	RTD 3 STAGE 2	RTD-Box		-50 .. 250 °C; ∞	120 °C	RTD 3: Temperature Stage 2 Pickup
9036	RTD 3 STAGE 2	RTD-Box		-58 .. 482 °F; ∞	248 °F	RTD 3: Temperature Stage 2 Pickup
9041A	RTD 4 TYPE	RTD-Box		Not connected Pt 100 Ω Ni 120 Ω Ni 100 Ω	Not connected	RTD 4: Type
9042A	RTD 4 LOCATION	RTD-Box		Oil Ambient Winding Bearing Other	Other	RTD 4: Location
9043	RTD 4 STAGE 1	RTD-Box		-50 .. 250 °C; ∞	100 °C	RTD 4: Temperature Stage 1 Pickup
9044	RTD 4 STAGE 1	RTD-Box		-58 .. 482 °F; ∞	212 °F	RTD 4: Temperature Stage 1 Pickup
9045	RTD 4 STAGE 2	RTD-Box		-50 .. 250 °C; ∞	120 °C	RTD 4: Temperature Stage 2 Pickup
9046	RTD 4 STAGE 2	RTD-Box		-58 .. 482 °F; ∞	248 °F	RTD 4: Temperature Stage 2 Pickup
9051A	RTD 5 TYPE	RTD-Box		Not connected Pt 100 Ω Ni 120 Ω Ni 100 Ω	Not connected	RTD 5: Type
9052A	RTD 5 LOCATION	RTD-Box		Oil Ambient Winding Bearing Other	Other	RTD 5: Location
9053	RTD 5 STAGE 1	RTD-Box		-50 .. 250 °C; ∞	100 °C	RTD 5: Temperature Stage 1 Pickup
9054	RTD 5 STAGE 1	RTD-Box		-58 .. 482 °F; ∞	212 °F	RTD 5: Temperature Stage 1 Pickup
9055	RTD 5 STAGE 2	RTD-Box		-50 .. 250 °C; ∞	120 °C	RTD 5: Temperature Stage 2 Pickup
9056	RTD 5 STAGE 2	RTD-Box		-58 .. 482 °F; ∞	248 °F	RTD 5: Temperature Stage 2 Pickup
9061A	RTD 6 TYPE	RTD-Box		Not connected Pt 100 Ω Ni 120 Ω Ni 100 Ω	Not connected	RTD 6: Type
9062A	RTD 6 LOCATION	RTD-Box		Oil Ambient Winding Bearing Other	Other	RTD 6: Location
9063	RTD 6 STAGE 1	RTD-Box		-50 .. 250 °C; ∞	100 °C	RTD 6: Temperature Stage 1 Pickup
9064	RTD 6 STAGE 1	RTD-Box		-58 .. 482 °F; ∞	212 °F	RTD 6: Temperature Stage 1 Pickup

Addr.	Parameter	Function	C	Setting Options	Default Setting	Comments
9065	RTD 6 STAGE 2	RTD-Box		-50 .. 250 °C; ∞	120 °C	RTD 6: Temperature Stage 2 Pickup
9066	RTD 6 STAGE 2	RTD-Box		-58 .. 482 °F; ∞	248 °F	RTD 6: Temperature Stage 2 Pickup
9071A	RTD 7 TYPE	RTD-Box		Not connected Pt 100 Ω Ni 120 Ω Ni 100 Ω	Not connected	RTD 7: Type
9072A	RTD 7 LOCATION	RTD-Box		Oil Ambient Winding Bearing Other	Other	RTD 7: Location
9073	RTD 7 STAGE 1	RTD-Box		-50 .. 250 °C; ∞	100 °C	RTD 7: Temperature Stage 1 Pickup
9074	RTD 7 STAGE 1	RTD-Box		-58 .. 482 °F; ∞	212 °F	RTD 7: Temperature Stage 1 Pickup
9075	RTD 7 STAGE 2	RTD-Box		-50 .. 250 °C; ∞	120 °C	RTD 7: Temperature Stage 2 Pickup
9076	RTD 7 STAGE 2	RTD-Box		-58 .. 482 °F; ∞	248 °F	RTD 7: Temperature Stage 2 Pickup
9081A	RTD 8 TYPE	RTD-Box		Not connected Pt 100 Ω Ni 120 Ω Ni 100 Ω	Not connected	RTD 8: Type
9082A	RTD 8 LOCATION	RTD-Box		Oil Ambient Winding Bearing Other	Other	RTD 8: Location
9083	RTD 8 STAGE 1	RTD-Box		-50 .. 250 °C; ∞	100 °C	RTD 8: Temperature Stage 1 Pickup
9084	RTD 8 STAGE 1	RTD-Box		-58 .. 482 °F; ∞	212 °F	RTD 8: Temperature Stage 1 Pickup
9085	RTD 8 STAGE 2	RTD-Box		-50 .. 250 °C; ∞	120 °C	RTD 8: Temperature Stage 2 Pickup
9086	RTD 8 STAGE 2	RTD-Box		-58 .. 482 °F; ∞	248 °F	RTD 8: Temperature Stage 2 Pickup
9091A	RTD 9 TYPE	RTD-Box		Not connected Pt 100 Ω Ni 120 Ω Ni 100 Ω	Not connected	RTD 9: Type
9092A	RTD 9 LOCATION	RTD-Box		Oil Ambient Winding Bearing Other	Other	RTD 9: Location
9093	RTD 9 STAGE 1	RTD-Box		-50 .. 250 °C; ∞	100 °C	RTD 9: Temperature Stage 1 Pickup
9094	RTD 9 STAGE 1	RTD-Box		-58 .. 482 °F; ∞	212 °F	RTD 9: Temperature Stage 1 Pickup
9095	RTD 9 STAGE 2	RTD-Box		-50 .. 250 °C; ∞	120 °C	RTD 9: Temperature Stage 2 Pickup
9096	RTD 9 STAGE 2	RTD-Box		-58 .. 482 °F; ∞	248 °F	RTD 9: Temperature Stage 2 Pickup
9101A	RTD10 TYPE	RTD-Box		Not connected Pt 100 Ω Ni 120 Ω Ni 100 Ω	Not connected	RTD10: Type
9102A	RTD10 LOCATION	RTD-Box		Oil Ambient Winding Bearing Other	Other	RTD10: Location
9103	RTD10 STAGE 1	RTD-Box		-50 .. 250 °C; ∞	100 °C	RTD10: Temperature Stage 1 Pickup
9104	RTD10 STAGE 1	RTD-Box		-58 .. 482 °F; ∞	212 °F	RTD10: Temperature Stage 1 Pickup

Addr.	Parameter	Function	C	Setting Options	Default Setting	Comments
9105	RTD10 STAGE 2	RTD-Box		-50 .. 250 °C; ∞	120 °C	RTD10: Temperature Stage 2 Pickup
9106	RTD10 STAGE 2	RTD-Box		-58 .. 482 °F; ∞	248 °F	RTD10: Temperature Stage 2 Pickup
9111A	RTD11 TYPE	RTD-Box		Not connected Pt 100 Ω Ni 120 Ω Ni 100 Ω	Not connected	RTD11: Type
9112A	RTD11 LOCATION	RTD-Box		Oil Ambient Winding Bearing Other	Other	RTD11: Location
9113	RTD11 STAGE 1	RTD-Box		-50 .. 250 °C; ∞	100 °C	RTD11: Temperature Stage 1 Pickup
9114	RTD11 STAGE 1	RTD-Box		-58 .. 482 °F; ∞	212 °F	RTD11: Temperature Stage 1 Pickup
9115	RTD11 STAGE 2	RTD-Box		-50 .. 250 °C; ∞	120 °C	RTD11: Temperature Stage 2 Pickup
9116	RTD11 STAGE 2	RTD-Box		-58 .. 482 °F; ∞	248 °F	RTD11: Temperature Stage 2 Pickup
9121A	RTD12 TYPE	RTD-Box		Not connected Pt 100 Ω Ni 120 Ω Ni 100 Ω	Not connected	RTD12: Type
9122A	RTD12 LOCATION	RTD-Box		Oil Ambient Winding Bearing Other	Other	RTD12: Location
9123	RTD12 STAGE 1	RTD-Box		-50 .. 250 °C; ∞	100 °C	RTD12: Temperature Stage 1 Pickup
9124	RTD12 STAGE 1	RTD-Box		-58 .. 482 °F; ∞	212 °F	RTD12: Temperature Stage 1 Pickup
9125	RTD12 STAGE 2	RTD-Box		-50 .. 250 °C; ∞	120 °C	RTD12: Temperature Stage 2 Pickup
9126	RTD12 STAGE 2	RTD-Box		-58 .. 482 °F; ∞	248 °F	RTD12: Temperature Stage 2 Pickup

A.9 Information List

Indications for IEC 60 870-5-103 are always reported ON / OFF if they are subject to general interrogation for IEC 60 870-5-103. If not, they are reported only as ON.

New user-defined indications or such newly allocated to IEC 60 870-5-103 are set to ON / OFF and subjected to general interrogation if the information type is not a spontaneous event („...Ev“). Further information with regard to the indications is set out in the SIPROTEC 4 System Description, Order No. E50417-H1100-C151.

In columns „Event Log“, „Trip Log“ and „Ground Fault Log“ the following applies:

UPPER CASE NOTATION “ON/OFF”: definitely set, not allocatable

lower case notation “on/off”: preset, allocatable

*: not preset, allocatable

<blank>: neither preset nor allocatable

In column „Marked in Oscill.Record“ the following applies:

UPPER CASE NOTATION “M”: definitely set, not allocatable

lower case notation “m”: preset, allocatable

*: not preset, allocatable

<blank>: neither preset nor allocatable

No.	Description	Function	Type of Information	Log Buffers				Configurable in Matrix					IEC 60870-5-103				
				Event Log ON/OFF	Trip (Fault) Log ON/OFF	Ground Fault Log ON/OFF	Marked in Oscill. Record	LED	Binary Input	Function Key	Relay	Chatter Suppression	Type	Information Number	Data Unit	General Interrogation	
-	>Back Light on (>Light on)	Device, General	SP	On Off	*		*	LED	BI	BO							
-	Reset LED (Reset LED)	Device, General	IntSP	on	*		*	LED		BO		160	19	1	No		
-	Stop data transmission (DataS-top)	Device, General	IntSP	On Off	*		*	LED		BO		160	20	1	Yes		
-	Test mode (Test mode)	Device, General	IntSP	On Off	*		*	LED		BO		160	21	1	Yes		
-	Feeder GROUNDED (Feeder gnd)	Device, General	IntSP	*	*		*	LED		BO							
-	Breaker OPENED (Brk OPENED)	Device, General	IntSP	*	*		*	LED		BO							
-	Hardware Test Mode (HWTest-Mod)	Device, General	IntSP	On Off	*		*	LED		BO							
-	Clock Synchronization (Synch-Clock)	Device, General	IntSP_Ev	*	*		*										
-	Error FMS FO 1 (Error FMS1)	Device, General	OUT	On Off	*			LED		BO							
-	Error FMS FO 2 (Error FMS2)	Device, General	OUT	On Off	*			LED		BO							
-	Disturbance CFC (Distur.CFC)	Device, General	OUT	On Off	*			LED		BO							
-	Fault Recording Start (FitRecSta)	Osc. Fault Rec.	IntSP	On Off	*		m	LED		BO							
-	Setting Group A is active (GroupA act)	Change Group	IntSP	On Off	*		*	LED		BO		160	23	1	Yes		
-	Setting Group B is active (GroupB act)	Change Group	IntSP	On Off	*		*	LED		BO		160	24	1	Yes		

No.	Description	Function	Type of Information	Log Buffers				Configurable in Matrix					IEC 60870-5-103			
				Event Log ON/OFF	Trip (Fault) Log ON/OFF	Ground Fault Log ON/OFF	Marked in Oscill. Record	LED	Binary Input	Function Key	Relay	Chatter Suppression	Type	Information Number	Data Unit	General Interrogation
-	Setting Group C is active (GroupC act)	Change Group	IntSP	On Off	*		*	LED			BO	160	25	1	Yes	
-	Setting Group D is active (GroupD act)	Change Group	IntSP	On Off	*		*	LED			BO	160	26	1	Yes	
-	Controlmode REMOTE (ModeREMOTE)	Cntrl Authority	IntSP	On Off	*			LED			BO					
-	Control Authority (Cntrl Auth)	Cntrl Authority	IntSP	On Off	*			LED			BO	101	85	1	Yes	
-	Controlmode LOCAL (ModeLOCAL)	Cntrl Authority	IntSP	On Off	*			LED			BO	101	86	1	Yes	
-	52 Breaker (52Breaker)	Control Device	CF_D12	On Off				LED			BO	240	160	20		
-	52 Breaker (52Breaker)	Control Device	DP	On Off					BI		CB	240	160	1	Yes	
-	Disconnect Switch (Disc.Swit.)	Control Device	CF_D2	On Off				LED			BO	240	161	20		
-	Disconnect Switch (Disc.Swit.)	Control Device	DP	On Off					BI		CB	240	161	1	Yes	
-	Ground Switch (GndSwit.)	Control Device	CF_D2	On Off				LED			BO	240	164	20		
-	Ground Switch (GndSwit.)	Control Device	DP	On Off					BI		CB	240	164	1	Yes	
-	Interlocking: 52 Open (52 Open)	Control Device	IntSP				*	LED			BO					
-	Interlocking: 52 Close (52 Close)	Control Device	IntSP				*	LED			BO					
-	Interlocking: Disconnect switch Open (Disc.Open)	Control Device	IntSP				*	LED			BO					
-	Interlocking: Disconnect switch Close (Disc.Close)	Control Device	IntSP				*	LED			BO					
-	Interlocking: Ground switch Open (GndSw Open)	Control Device	IntSP				*	LED			BO					
-	Interlocking: Ground switch Close (GndSw Cl.)	Control Device	IntSP				*	LED			BO					
-	Unlock data transmission via BI (UnlockDT)	Control Device	IntSP				*	LED			BO					
-	Q2 Open/Close (Q2 Op/Cl)	Control Device	CF_D2	On Off				LED			BO	240	162	20		
-	Q2 Open/Close (Q2 Op/Cl)	Control Device	DP	On Off					BI		CB	240	162	1	Yes	
-	Q9 Open/Close (Q9 Op/Cl)	Control Device	CF_D2	On Off				LED			BO	240	163	20		
-	Q9 Open/Close (Q9 Op/Cl)	Control Device	DP	On Off					BI		CB	240	163	1	Yes	
-	Fan ON/OFF (Fan ON/OFF)	Control Device	CF_D2	On Off				LED			BO	240	175	20		
-	Fan ON/OFF (Fan ON/OFF)	Control Device	DP	On Off					BI		CB	240	175	1	Yes	
-	>CB ready Spring is charged (>CB ready)	Process Data	SP	*	*		*	LED	BI		BO	CB				
-	>Door closed (>DoorClose)	Process Data	SP	*	*		*	LED	BI		BO	CB				
-	>Cabinet door open (>Door open)	Process Data	SP	On Off	*		*	LED	BI		BO	CB	101	1	1	Yes
-	>CB waiting for Spring charged (>CB wait)	Process Data	SP	On Off	*		*	LED	BI		BO	CB	101	2	1	Yes
-	>No Voltage (Fuse blown) (>No Volt.)	Process Data	SP	On Off	*		*	LED	BI		BO	CB	160	38	1	Yes

No.	Description	Function	Type of Information	Log Buffers				Configurable in Matrix					IEC 60870-5-103		
				Event Log ON/OFF	Trip (Fault) Log ON/OFF	Ground Fault Log ON/OFF	Marked in Oscill. Record	LED	Binary Input	Function Key	Relay	Chatter Suppression	Type	Information Number	Data Unit
-	>Error Motor Voltage (>Err Mot V)	Process Data	SP	On Off	*		*	LED	BI	BO	CB	240	181	1	Yes
-	>Error Control Voltage (>ErrCtr-IV)	Process Data	SP	On Off	*		*	LED	BI	BO	CB	240	182	1	Yes
-	>SF6-Loss (>SF6-Loss)	Process Data	SP	On Off	*		*	LED	BI	BO	CB	240	183	1	Yes
-	>Error Meter (>Err Meter)	Process Data	SP	On Off	*		*	LED	BI	BO	CB	240	184	1	Yes
-	>Transformer Temperature (>Tx Temp.)	Process Data	SP	On Off	*		*	LED	BI	BO	CB	240	185	1	Yes
-	>Transformer Danger (>Tx Danger)	Process Data	SP	On Off	*		*	LED	BI	BO	CB	240	186	1	Yes
-	Reset Minimum and Maximum counter (ResMinMax)	Min/Max meter	IntSP_Ev	ON											
-	Reset meter (Meter res)	Energy	IntSP_Ev	ON					BI						
-	Error Systeminterface (SysIntErr.)	Protocol	IntSP	On Off	*	*		LED			BO				
-	Threshold Value 1 (ThreshVal1)	Thresh.-Switch	IntSP	On Off				LED		FC TN	BO	CB			
1	No Function configured (Not configured)	Device, General	SP	*	*										
2	Function Not Available (Non Existent)	Device, General	SP	*	*										
3	>Synchronize Internal Real Time Clock (>Time Synch)	Device, General	SP_Ev	*	*			LED	BI		BO	135	48	1	Yes
4	>Trigger Waveform Capture (>Trig.Wave.Cap.)	Osc. Fault Rec.	SP	*	*		m	LED	BI		BO	135	49	1	Yes
5	>Reset LED (>Reset LED)	Device, General	SP	*	*		*	LED	BI		BO	135	50	1	Yes
7	>Setting Group Select Bit 0 (>Set Group Bit0)	Change Group	SP	*	*		*	LED	BI		BO	135	51	1	Yes
8	>Setting Group Select Bit 1 (>Set Group Bit1)	Change Group	SP	*	*		*	LED	BI		BO	135	52	1	Yes
009.0100	Failure EN100 Modul (Failure Modul)	EN100-Modul 1	IntSP	On Off	*		*	LED			BO				
009.0101	Failure EN100 Link Channel 1 (Ch1) (Fail Ch1)	EN100-Modul 1	IntSP	On Off	*		*	LED			BO				
009.0102	Failure EN100 Link Channel 2 (Ch2) (Fail Ch2)	EN100-Modul 1	IntSP	On Off	*		*	LED			BO				
15	>Test mode (>Test mode)	Device, General	SP	*	*		*	LED	BI		BO	135	53	1	Yes
16	>Stop data transmission (>DataStop)	Device, General	SP	*	*		*	LED	BI		BO	135	54	1	Yes
51	Device is Operational and Protecting (Device OK)	Device, General	OUT	On Off	*		*	LED			BO	135	81	1	Yes
52	At Least 1 Protection Funct. is Active (ProtActive)	Device, General	IntSP	On Off	*		*	LED			BO	160	18	1	Yes
55	Reset Device (Reset Device)	Device, General	OUT	on	*		*					160	4	1	No
56	Initial Start of Device (Initial Start)	Device, General	OUT	on	*		*	LED			BO	160	5	1	No
67	Resume (Resume)	Device, General	OUT	on	*		*	LED			BO				
68	Clock Synchronization Error (Clock SyncError)	Device, General	OUT	On Off	*		*	LED			BO				
69	Daylight Saving Time (DayLight-SavTime)	Device, General	OUT	On Off	*		*	LED			BO				
70	Setting calculation is running (Settings Calc.)	Device, General	OUT	On Off	*		*	LED			BO	160	22	1	Yes

No.	Description	Function	Type of Information	Log Buffers				Configurable in Matrix				IEC 60870-5-103					
				Event Log ON/OFF	Trip (Fault) Log ON/OFF	Ground Fault Log ON/OFF	Marked in Oscill. Record	LED	Binary Input	Function Key	Relay	Chatter Suppression	Type	Information Number	Data Unit	General Interrogation	
71	Settings Check (Settings Check)	Device, General	OUT	*	*		*	LED			BO						
72	Level-2 change (Level-2 change)	Device, General	OUT	On Off	*		*	LED			BO						
73	Local setting change (Local change)	Device, General	OUT	*	*		*										
110	Event lost (Event Lost)	Device, General	OUT_Ev	on	*			LED			BO	135	130	1	No		
113	Flag Lost (Flag Lost)	Device, General	OUT	on	*		m	LED			BO	135	136	1	Yes		
125	Chatter ON (Chatter ON)	Device, General	OUT	On Off	*		*	LED			BO	135	145	1	Yes		
126	Protection ON/OFF (via system port) (ProtON/OFF)	P.System Data 2	IntSP	On Off	*		*	LED			BO						
127	79 ON/OFF (via system port) (79 ON/OFF)	79M Auto Recl.	IntSP	On Off	*		*	LED			BO						
140	Error with a summary alarm (Error Sum Alarm)	Device, General	OUT	On Off	*		*	LED			BO	160	47	1	Yes		
144	Error 5V (Error 5V)	Device, General	OUT	On Off	*		*	LED			BO						
145	Error 0V (Error 0V)	Device, General	OUT	On Off	*		*	LED			BO						
146	Error -5V (Error -5V)	Device, General	OUT	On Off	*		*	LED			BO						
147	Error Power Supply (Error Pwr-Supply)	Device, General	OUT	On Off	*		*	LED			BO						
160	Alarm Summary Event (Alarm Sum Event)	Device, General	OUT	On Off	*		*	LED			BO	160	46	1	Yes		
161	Failure: General Current Supervision (Fail I Superv.)	Measur em.Superv	OUT	On Off	*		*	LED			BO	160	32	1	Yes		
162	Failure: Current Summation (Failure Σ I)	Measur em.Superv	OUT	On Off	*		*	LED			BO	135	182	1	Yes		
163	Failure: Current Balance (Fail I balance)	Measur em.Superv	OUT	On Off	*		*	LED			BO	135	183	1	Yes		
175	Failure: Phase Sequence Current (Fail Ph. Seq. I)	Measur em.Superv	OUT	On Off	*		*	LED			BO	135	191	1	Yes		
177	Failure: Battery empty (Fail Battery)	Device, General	OUT	On Off	*		*	LED			BO						
178	I/O-Board Error (I/O-Board error)	Device, General	OUT	On Off	*		*	LED			BO						
181	Error: A/D converter (Error A/D-conv.)	Device, General	OUT	On Off	*		*	LED			BO						
183	Error Board 1 (Error Board 1)	Device, General	OUT	On Off	*		*	LED			BO						
184	Error Board 2 (Error Board 2)	Device, General	OUT	On Off	*		*	LED			BO						
185	Error Board 3 (Error Board 3)	Device, General	OUT	On Off	*		*	LED			BO						
186	Error Board 4 (Error Board 4)	Device, General	OUT	On Off	*		*	LED			BO						
187	Error Board 5 (Error Board 5)	Device, General	OUT	On Off	*		*	LED			BO						
188	Error Board 6 (Error Board 6)	Device, General	OUT	On Off	*		*	LED			BO						
189	Error Board 7 (Error Board 7)	Device, General	OUT	On Off	*		*	LED			BO						
191	Error: Offset (Error Offset)	Device, General	OUT	On Off	*		*	LED			BO						

No.	Description	Function	Type of Information	Log Buffers				Configurable in Matrix					IEC 60870-5-103					
				Event Log ON/OFF	Trip (Fault) Log ON/OFF	Ground Fault Log ON/OFF	Marked in Oscill. Record	LED	Binary Input	Function Key	Relay	Chatter Suppression	Type	Information Number	Data Unit	General Interrogation		
192	Error:1A/5Ajumper different from setting (Error1A/5Awrong)	Device, General	OUT	On Off	*													
193	Alarm: NO calibration data available (Alarm NO calibr)	Device, General	OUT	On Off	*		*	LED				BO						
194	Error: Neutral CT different from MLFB (Error neutralCT)	Device, General	OUT	On Off	*													
197	Measurement Supervision is switched OFF (MeasSup OFF)	Measurment.Superv	OUT	On Off	*		*	LED				BO		135	197	1	Yes	
203	Waveform data deleted (Wave. deleted)	Osc. Fault Rec.	OUT_Ev	on	*			LED				BO		135	203	1	No	
220	Error: Range CT Ph wrong (CT Ph wrong)	Device, General	OUT	On Off	*													
235.2110	>BLOCK Function \$00 (>BLOCK \$00)	Flx	SP	On Off	On Off	*	*	LED	BI	FC TN	BO							
235.2111	>Function \$00 instantaneous TRIP (>\$00 instant.)	Flx	SP	On Off	On Off	*	*	LED	BI	FC TN	BO							
235.2112	>Function \$00 Direct TRIP (>\$00 Dir.TRIP)	Flx	SP	On Off	On Off	*	*	LED	BI	FC TN	BO							
235.2113	>Function \$00 BLOCK TRIP Time Delay (>\$00 BLK.TDly)	Flx	SP	On Off	On Off	*	*	LED	BI	FC TN	BO							
235.2114	>Function \$00 BLOCK TRIP (>\$00 BLK.TRIP)	Flx	SP	On Off	On Off	*	*	LED	BI	FC TN	BO							
235.2115	>Function \$00 BLOCK TRIP Phase A (>\$00 BL.TripA)	Flx	SP	On Off	On Off	*	*	LED	BI	FC TN	BO							
235.2116	>Function \$00 BLOCK TRIP Phase B (>\$00 BL.TripB)	Flx	SP	On Off	On Off	*	*	LED	BI	FC TN	BO							
235.2117	>Function \$00 BLOCK TRIP Phase C (>\$00 BL.TripC)	Flx	SP	On Off	On Off	*	*	LED	BI	FC TN	BO							
235.2118	Function \$00 is BLOCKED (\$00 BLOCKED)	Flx	OUT	On Off	On Off	*	*	LED			BO							
235.2119	Function \$00 is switched OFF (\$00 OFF)	Flx	OUT	On Off	*	*	*	LED			BO							
235.2120	Function \$00 is ACTIVE (\$00 ACTIVE)	Flx	OUT	On Off	*	*	*	LED			BO							
235.2121	Function \$00 picked up (\$00 picked up)	Flx	OUT	On Off	On Off	*	*	LED			BO							
235.2122	Function \$00 Pickup Phase A (\$00 pickup A)	Flx	OUT	On Off	On Off	*	*	LED			BO							
235.2123	Function \$00 Pickup Phase B (\$00 pickup B)	Flx	OUT	On Off	On Off	*	*	LED			BO							
235.2124	Function \$00 Pickup Phase C (\$00 pickup C)	Flx	OUT	On Off	On Off	*	*	LED			BO							
235.2125	Function \$00 TRIP Delay Time Out (\$00 Time Out)	Flx	OUT	On Off	On Off	*	*	LED			BO							
235.2126	Function \$00 TRIP (\$00 TRIP)	Flx	OUT	On Off	on	*	*	LED			BO							
235.2128	Function \$00 has invalid settings (\$00 inval.set)	Flx	OUT	On Off	On Off	*	*	LED			BO							
236.2127	BLOCK Flexible Function (BLK. Flex.Fct.)	Device, General	IntSP	On Off	*	*	*	LED			BO							
264	Failure: RTD-Box 1 (Fail: RTD-Box 1)	RTD-Box	OUT	On Off	*		*	LED			BO							
267	Failure: RTD-Box 2 (Fail: RTD-Box 2)	RTD-Box	OUT	On Off	*		*	LED			BO							
272	Set Point Operating Hours (SP. Op Hours->)	SetPoint(Stat)	OUT	On Off	*		*	LED			BO		135	229	1	Yes		

No.	Description	Function	Type of Information	Log Buffers				Configurable in Matrix				IEC 60870-5-103			
				Event Log ON/OFF	Trip (Fault) Log ON/OFF	Ground Fault Log ON/OFF	Marked in Oscill. Record	LED	Binary Input	Function Key	Relay	Chatter Suppression	Type	Information Number	Data Unit
273	Set Point Phase A dmd> (SP. I A dmd>)	Set Points(MV)	OUT	On Off	*		*	LED			BO	135	230	1	Yes
274	Set Point Phase B dmd> (SP. I B dmd>)	Set Points(MV)	OUT	On Off	*		*	LED			BO	135	234	1	Yes
275	Set Point Phase C dmd> (SP. I C dmd>)	Set Points(MV)	OUT	On Off	*		*	LED			BO	135	235	1	Yes
276	Set Point positive sequence I1dmd> (SP. I1dmd>)	Set Points(MV)	OUT	On Off	*		*	LED			BO	135	236	1	Yes
284	Set Point 37-1 Undercurrent alarm (SP. 37-1 alarm)	Set Points(MV)	OUT	On Off	*		*	LED			BO	135	244	1	Yes
301	Power System fault (Pow.Sys.Fit.)	Device, General	OUT	On Off	On Off							135	231	2	Yes
302	Fault Event (Fault Event)	Device, General	OUT	*	on							135	232	2	Yes
303	sensitive Ground fault (sens Gnd fit)	Device, General	OUT	On Off	*	ON						135	233	1	Yes
320	Warn: Limit of Memory Data exceeded (Warn Mem. Data)	Device, General	OUT	On Off	*		*	LED			BO				
321	Warn: Limit of Memory Parameter exceeded (Warn Mem. Para.)	Device, General	OUT	On Off	*		*	LED			BO				
322	Warn: Limit of Memory Operation exceeded (Warn Mem. Oper.)	Device, General	OUT	On Off	*		*	LED			BO				
323	Warn: Limit of Memory New exceeded (Warn Mem. New)	Device, General	OUT	On Off	*		*	LED			BO				
356	>Manual close signal (>Manual Close)	P.System Data 2	SP	*	*		*	LED	BI		BO	150	6	1	Yes
395	>I MIN/MAX Buffer Reset (>I MinMax Reset)	Min/Max meter	SP	on	*		*	LED	BI		BO				
396	>I1 MIN/MAX Buffer Reset (>I1 MiMaReset)	Min/Max meter	SP	on	*		*	LED	BI		BO				
403	>Idmd MIN/MAX Buffer Reset (>Idmd MiMaReset)	Min/Max meter	SP	on	*		*	LED	BI		BO				
409	>BLOCK Op Counter (>BLOCK Op Count)	Statistics	SP	On Off			*	LED	BI		BO				
412	>Theta MIN/MAX Buffer Reset (>Θ MiMa Reset)	Min/Max meter	SP	on	*		*	LED	BI		BO				
501	Relay PICKUP (Relay PICKUP)	P.System Data 2	OUT		ON		m	LED			BO	150	151	2	Yes
502	Relay Drop Out (Relay Drop Out)	Device, General	SP	*	*										
510	General CLOSE of relay (Relay CLOSE)	Device, General	SP	*	*										
511	Relay GENERAL TRIP command (Relay TRIP)	P.System Data 2	OUT		ON		m	LED			BO	150	161	2	Yes
533	Primary fault current Ia (Ia =)	P.System Data 2	VI		On Off							150	177	4	No
534	Primary fault current Ib (Ib =)	P.System Data 2	VI		On Off							150	178	4	No
535	Primary fault current Ic (Ic =)	P.System Data 2	VI		On Off							150	179	4	No
545	Time from Pickup to drop out (PU Time)	Device, General	VI												
546	Time from Pickup to TRIP (TRIP Time)	Device, General	VI												
561	Manual close signal detected (Man.Clos.Detect)	P.System Data 2	OUT	On Off	*		*	LED			BO				
916	Increment of active energy (WpΔ=)	Energy	-												

No.	Description	Function	Type of Information	Log Buffers			Configurable in Matrix					IEC 60870-5-103					
				Event Log ON/OFF	Trip (Fault) Log ON/OFF	Ground Fault Log ON/OFF	Marked in Oscill. Record	LED	Binary Input	Function Key	Relay	Chatter Suppression	Type	Information Number	Data Unit	General Interrogation	
917	Increment of reactive energy (WqΔ=)	Energy	-														
1020	Counter of operating hours (Op.Hours=)	Statistics	VI														
1021	Accumulation of interrupted current Ph A ($\Sigma I_a =$)	Statistics	VI														
1022	Accumulation of interrupted current Ph B ($\Sigma I_b =$)	Statistics	VI														
1023	Accumulation of interrupted current Ph C ($\Sigma I_c =$)	Statistics	VI														
1202	>BLOCK 50Ns-2 (>BLOCK 50Ns-2)	Sens. Gnd Fault	SP	On Off	*		*	LED	BI		BO		151	102	1	Yes	
1203	>BLOCK 50Ns-1 (>BLOCK 50Ns-1)	Sens. Gnd Fault	SP	On Off	*		*	LED	BI		BO		151	103	1	Yes	
1204	>BLOCK 51Ns (>BLOCK 51Ns)	Sens. Gnd Fault	SP	On Off	*		*	LED	BI		BO		151	104	1	Yes	
1207	>BLOCK 50Ns/67Ns (>BLK 50Ns/67Ns)	Sens. Gnd Fault	SP	On Off	*		*	LED	BI		BO		151	107	1	Yes	
1211	50Ns/67Ns is OFF (50Ns/67Ns OFF)	Sens. Gnd Fault	OUT	On Off	*		*	LED			BO		151	111	1	Yes	
1212	50Ns/67Ns is ACTIVE (50Ns/67Ns ACT)	Sens. Gnd Fault	OUT	On Off	*		*	LED			BO		151	112	1	Yes	
1221	50Ns-2 Pickup (50Ns-2 Pickup)	Sens. Gnd Fault	OUT	*	On Off			LED			BO		151	121	2	Yes	
1223	50Ns-2 TRIP (50Ns-2 TRIP)	Sens. Gnd Fault	OUT	*	on			LED			BO		151	123	2	Yes	
1224	50Ns-1 Pickup (50Ns-1 Pickup)	Sens. Gnd Fault	OUT	*	On Off			LED			BO		151	124	2	Yes	
1226	50Ns-1 TRIP (50Ns-1 TRIP)	Sens. Gnd Fault	OUT	*	on			LED			BO		151	126	2	Yes	
1227	51Ns picked up (51Ns Pickup)	Sens. Gnd Fault	OUT	*	On Off			LED			BO		151	127	2	Yes	
1229	51Ns TRIP (51Ns TRIP)	Sens. Gnd Fault	OUT	*	on			LED			BO		151	129	2	Yes	
1230	Sensitive ground fault detection BLOCKED (Sens. Gnd block)	Sens. Gnd Fault	OUT	On Off	On Off		*	LED			BO		151	130	1	Yes	
1403	>BLOCK 50BF (>BLOCK 50BF)	50BF BkrFailure	SP	On Off	*		*	LED	BI		BO		166	103	1	Yes	
1431	>50BF initiated externally (>50BF ext SRC)	50BF BkrFailure	SP	On Off	*		*	LED	BI		BO		166	104	1	Yes	
1451	50BF is switched OFF (50BF OFF)	50BF BkrFailure	OUT	On Off	*		*	LED			BO		166	151	1	Yes	
1452	50BF is BLOCKED (50BF BLOCK)	50BF BkrFailure	OUT	On Off	On Off		*	LED			BO		166	152	1	Yes	
1453	50BF is ACTIVE (50BF ACTIVE)	50BF BkrFailure	OUT	On Off	*		*	LED			BO		166	153	1	Yes	
1456	50BF (internal) PICKUP (50BF int Pickup)	50BF BkrFailure	OUT	*	On Off		*	LED			BO		166	156	2	Yes	
1457	50BF (external) PICKUP (50BF ext Pickup)	50BF BkrFailure	OUT	*	On Off		*	LED			BO		166	157	2	Yes	
1471	50BF TRIP (50BF TRIP)	50BF BkrFailure	OUT	*	on			LED			BO		160	85	2	No	
1480	50BF (internal) TRIP (50BF int TRIP)	50BF BkrFailure	OUT	*	on		*	LED			BO		166	180	2	Yes	
1481	50BF (external) TRIP (50BF ext TRIP)	50BF BkrFailure	OUT	*	on		*	LED			BO		166	181	2	Yes	
1503	>BLOCK 49 Overload Protection (>BLOCK 49 O/L)	49 Th.Overload	SP	*	*		*	LED	BI		BO		167	3	1	Yes	

No.	Description	Function	Type of Information	Log Buffers				Configurable in Matrix				IEC 60870-5-103			
				Event Log ON/OFF	Trip (Fault) Log ON/OFF	Ground Fault Log ON/OFF	Marked in Oscill. Record	LED	Binary Input	Function Key	Relay	Chatter Suppression	Type	Information Number	Data Unit
1507	>Emergency start of motors (>EmergencyStart)	49 Th.Overload	SP	On Off	*		*	LED	BI		BO	167	7	1	Yes
1511	49 Overload Protection is OFF (49 O / L OFF)	49 Th.Overload	OUT	On Off	*		*	LED			BO	167	11	1	Yes
1512	49 Overload Protection is BLOCKED (49 O/L BLOCK)	49 Th.Overload	OUT	On Off	On Off		*	LED			BO	167	12	1	Yes
1513	49 Overload Protection is ACTIVE (49 O/L ACTIVE)	49 Th.Overload	OUT	On Off	*		*	LED			BO	167	13	1	Yes
1515	49 Overload Current Alarm (I alarm) (49 O/L I Alarm)	49 Th.Overload	OUT	On Off	*		*	LED			BO	167	15	1	Yes
1516	49 Overload Alarm! Near Thermal Trip (49 O/L θ Alarm)	49 Th.Overload	OUT	On Off	*		*	LED			BO	167	16	1	Yes
1517	49 Winding Overload (49 Winding O/L)	49 Th.Overload	OUT	On Off	*		*	LED			BO	167	17	1	Yes
1521	49 Thermal Overload TRIP (49 Th O/L TRIP)	49 Th.Overload	OUT	*	on		m	LED			BO	167	21	2	Yes
1580	>49 Reset of Thermal Overload Image (>RES 49 Image)	49 Th.Overload	SP	On Off	*		*	LED	BI		BO				
1581	49 Thermal Overload Image reset (49 Image res.)	49 Th.Overload	OUT	On Off	*		*	LED			BO				
1704	>BLOCK 50/51 (>BLK 50/51)	50/51 Overcur.	SP	*	*		*	LED	BI		BO				
1714	>BLOCK 50N/51N (>BLK 50N/51N)	50/51 Overcur.	SP	*	*		*	LED	BI		BO				
1718	>BLOCK 50-3 (>BLOCK 50-3)	50/51 Overcur.	SP	*	*		*	LED	BI		BO				
1719	>BLOCK 50N-3 (>BLOCK 50N-3)	50/51 Overcur.	SP	*	*		*	LED	BI		BO				
1721	>BLOCK 50-2 (>BLOCK 50-2)	50/51 Overcur.	SP	*	*		*	LED	BI		BO	60	1	1	Yes
1722	>BLOCK 50-1 (>BLOCK 50-1)	50/51 Overcur.	SP	*	*		*	LED	BI		BO	60	2	1	Yes
1723	>BLOCK 51 (>BLOCK 51)	50/51 Overcur.	SP	*	*		*	LED	BI		BO	60	3	1	Yes
1724	>BLOCK 50N-2 (>BLOCK 50N-2)	50/51 Overcur.	SP	*	*		*	LED	BI		BO	60	4	1	Yes
1725	>BLOCK 50N-1 (>BLOCK 50N-1)	50/51 Overcur.	SP	*	*		*	LED	BI		BO	60	5	1	Yes
1726	>BLOCK 51N (>BLOCK 51N)	50/51 Overcur.	SP	*	*		*	LED	BI		BO	60	6	1	Yes
1730	>BLOCK Cold-Load-Pickup (>BLOCK CLP)	ColdLoadPickup	SP	*	*		*	LED	BI		BO				
1731	>BLOCK Cold-Load-Pickup stop timer (>BLK CLP stpTim)	ColdLoadPickup	SP	On Off	*		*	LED	BI		BO	60	243	1	Yes
1732	>ACTIVATE Cold-Load-Pickup (>ACTIVATE CLP)	ColdLoadPickup	SP	On Off	*		*	LED	BI		BO				
1751	50/51 O/C switched OFF (50/51 PH OFF)	50/51 Overcur.	OUT	On Off	*		*	LED			BO	60	21	1	Yes
1752	50/51 O/C is BLOCKED (50/51 PH BLK)	50/51 Overcur.	OUT	On Off	On Off		*	LED			BO	60	22	1	Yes
1753	50/51 O/C is ACTIVE (50/51 PH ACT)	50/51 Overcur.	OUT	On Off	*		*	LED			BO	60	23	1	Yes
1756	50N/51N is OFF (50N/51N OFF)	50/51 Overcur.	OUT	On Off	*		*	LED			BO	60	26	1	Yes
1757	50N/51N is BLOCKED (50N/51N BLK)	50/51 Overcur.	OUT	On Off	On Off		*	LED			BO	60	27	1	Yes
1758	50N/51N is ACTIVE (50N/51N ACT)	50/51 Overcur.	OUT	On Off	*		*	LED			BO	60	28	1	Yes
1761	50(N)/51(N) O/C PICKUP (50(N)/51(N) PU)	50/51 Overcur.	OUT	*	On Off		m	LED			BO	160	84	2	Yes
1762	50/51 Phase A picked up (50/51 Ph A PU)	50/51 Overcur.	OUT	*	On Off		m	LED			BO	160	64	2	Yes

No.	Description	Function	Type of Information	Log Buffers				Configurable in Matrix					IEC 60870-5-103		
				Event Log ON/OFF	Trip (Fault) Log ON/OFF	Ground Fault Log ON/OFF	Marked in Oscill. Record	LED	Binary Input	Function Key	Relay	Chatter Suppression	Type	Information Number	Data Unit
1763	50/51 Phase B picked up (50/51 Ph B PU)	50/51 Overcur.	OUT	*	On Off		m	LED			BO	160	65	2	Yes
1764	50/51 Phase C picked up (50/51 Ph C PU)	50/51 Overcur.	OUT	*	On Off		m	LED			BO	160	66	2	Yes
1765	50N/51N picked up (50N/51NPickedup)	50/51 Overcur.	OUT	*	On Off		m	LED			BO	160	67	2	Yes
1767	50-3 picked up (50-3 picked up)	50/51 Overcur.	OUT	*	On Off		*	LED			BO				
1768	50N-3 picked up (50N-3 picked up)	50/51 Overcur.	OUT	*	On Off		*	LED			BO				
1769	50-3 TRIP (50-3 TRIP)	50/51 Overcur.	OUT	*	on		*	LED			BO				
1770	50N-3 TRIP (50N-3 TRIP)	50/51 Overcur.	OUT	*	on		*	LED			BO				
1787	50-3 TimeOut (50-3 TimeOut)	50/51 Overcur.	OUT	*	*		*	LED			BO				
1788	50N-3 TimeOut (50N-3 TimeOut)	50/51 Overcur.	OUT	*	*		*	LED			BO				
1791	50(N)/51(N) TRIP (50(N)/51(N)TRIP)	50/51 Overcur.	OUT	*	on		m	LED			BO	160	68	2	No
1800	50-2 picked up (50-2 picked up)	50/51 Overcur.	OUT	*	On Off		*	LED			BO	60	75	2	Yes
1804	50-2 Time Out (50-2 TimeOut)	50/51 Overcur.	OUT	*	*		*	LED			BO	60	49	2	Yes
1805	50-2 TRIP (50-2 TRIP)	50/51 Overcur.	OUT	*	on		m	LED			BO	160	91	2	No
1810	50-1 picked up (50-1 picked up)	50/51 Overcur.	OUT	*	On Off		*	LED			BO	60	76	2	Yes
1814	50-1 Time Out (50-1 TimeOut)	50/51 Overcur.	OUT	*	*		*	LED			BO	60	53	2	Yes
1815	50-1 TRIP (50-1 TRIP)	50/51 Overcur.	OUT	*	on		m	LED			BO	160	90	2	No
1820	51 picked up (51 picked up)	50/51 Overcur.	OUT	*	On Off		*	LED			BO	60	77	2	Yes
1824	51 Time Out (51 Time Out)	50/51 Overcur.	OUT	*	*		*	LED			BO	60	57	2	Yes
1825	51 TRIP (51 TRIP)	50/51 Overcur.	OUT	*	on		m	LED			BO	60	58	2	Yes
1831	50N-2 picked up (50N-2 picked up)	50/51 Overcur.	OUT	*	On Off		*	LED			BO	60	59	2	Yes
1832	50N-2 Time Out (50N-2 TimeOut)	50/51 Overcur.	OUT	*	*		*	LED			BO	60	60	2	Yes
1833	50N-2 TRIP (50N-2 TRIP)	50/51 Overcur.	OUT	*	on		m	LED			BO	160	93	2	No
1834	50N-1 picked up (50N-1 picked up)	50/51 Overcur.	OUT	*	On Off		*	LED			BO	60	62	2	Yes
1835	50N-1 Time Out (50N-1 TimeOut)	50/51 Overcur.	OUT	*	*		*	LED			BO	60	63	2	Yes
1836	50N-1 TRIP (50N-1 TRIP)	50/51 Overcur.	OUT	*	on		m	LED			BO	160	92	2	No
1837	51N picked up (51N picked up)	50/51 Overcur.	OUT	*	On Off		*	LED			BO	60	64	2	Yes
1838	51N Time Out (51N TimeOut)	50/51 Overcur.	OUT	*	*		*	LED			BO	60	65	2	Yes
1839	51N TRIP (51N TRIP)	50/51 Overcur.	OUT	*	on		m	LED			BO	60	66	2	Yes
1840	Phase A inrush detection (PhA InrushDet)	50/51 Overcur.	OUT	*	On Off		*	LED			BO	60	101	2	Yes
1841	Phase B inrush detection (PhB InrushDet)	50/51 Overcur.	OUT	*	On Off		*	LED			BO	60	102	2	Yes
1842	Phase C inrush detection (PhC InrushDet)	50/51 Overcur.	OUT	*	On Off		*	LED			BO	60	103	2	Yes
1843	Cross blk: PhX blocked PhY (INRUSH X-BLK)	50/51 Overcur.	OUT	*	On Off		*	LED			BO	60	104	2	Yes
1851	50-1 BLOCKED (50-1 BLOCKED)	50/51 Overcur.	OUT		On Off		*	LED			BO	60	105	1	Yes
1852	50-2 BLOCKED (50-2 BLOCKED)	50/51 Overcur.	OUT		On Off		*	LED			BO	60	106	1	Yes

No.	Description	Function	Type of Information	Log Buffers				Configurable in Matrix					IEC 60870-5-103			
				Event Log ON/OFF	Trip (Fault) Log ON/OFF	Ground Fault Log ON/OFF	Marked in Oscill. Record	LED	Binary Input	Function Key	Relay	Chatter Suppression	Type	Information Number	Data Unit	General Interrogation
1853	50N-1 BLOCKED (50N-1 BLOCKED)	50/51 Overcur.	OUT	On Off	On Off		*	LED			BO	60	107	1	Yes	
1854	50N-2 BLOCKED (50N-2 BLOCKED)	50/51 Overcur.	OUT	On Off	On Off		*	LED			BO	60	108	1	Yes	
1855	51 BLOCKED (51 BLOCKED)	50/51 Overcur.	OUT	On Off	On Off		*	LED			BO	60	109	1	Yes	
1856	51N BLOCKED (51N BLOCKED)	50/51 Overcur.	OUT	On Off	On Off		*	LED			BO	60	110	1	Yes	
1866	51 Disk emulation Pickup (51 Disk Pickup)	50/51 Overcur.	OUT	*	*		*	LED			BO					
1867	51N Disk emulation picked up (51N Disk Pickup)	50/51 Overcur.	OUT	*	*		*	LED			BO					
1994	Cold-Load-Pickup switched OFF (CLP OFF)	ColdLoadPickup	OUT	On Off	*		*	LED			BO	60	244	1	Yes	
1995	Cold-Load-Pickup is BLOCKED (CLP BLOCKED)	ColdLoadPickup	OUT	On Off	On Off		*	LED			BO	60	245	1	Yes	
1996	Cold-Load-Pickup is RUNNING (CLP running)	ColdLoadPickup	OUT	On Off	*		*	LED			BO	60	246	1	Yes	
1997	Dynamic settings are ACTIVE (Dyn set. ACTIVE)	ColdLoadPickup	OUT	On Off	*		*	LED			BO	60	247	1	Yes	
2701	>79 ON (>79 ON)	79M Auto Recl.	SP	On Off	*		*	LED	BI		BO	40	1	1	Yes	
2702	>79 OFF (>79 OFF)	79M Auto Recl.	SP	On Off	*		*	LED	BI		BO	40	2	1	Yes	
2703	>BLOCK 79 (>BLOCK 79)	79M Auto Recl.	SP	On Off	*		*	LED	BI		BO	40	3	1	Yes	
2711	>79 External start of internal A/R (>79 Start)	79M Auto Recl.	SP	*	On Off		*	LED	BI		BO					
2715	>Start 79 Ground program (>Start 79 Gnd)	79M Auto Recl.	SP	*	on		*	LED	BI		BO	40	15	2	Yes	
2716	>Start 79 Phase program (>Start 79 Ph)	79M Auto Recl.	SP	*	on		*	LED	BI		BO	40	16	2	Yes	
2720	>Enable 50/67-(N)-2 (override 79 blk) (>Enable ANSI#-2)	P.System Data 2	SP	On Off	*		*	LED	BI		BO	40	20	1	Yes	
2722	>Switch zone sequence coordination ON (>ZSC ON)	79M Auto Recl.	SP	On Off	*		*	LED	BI		BO					
2723	>Switch zone sequence coordination OFF (>ZSC OFF)	79M Auto Recl.	SP	On Off	*		*	LED	BI		BO					
2730	>Circuit breaker READY for reclosing (>CB Ready)	79M Auto Recl.	SP	On Off	*		*	LED	BI		BO	40	30	1	Yes	
2731	>79: Sync. release from ext. sync.-check (>Sync.release)	79M Auto Recl.	SP	*	on		*	LED	BI		BO					
2753	79: Max. Dead Time Start Delay expired (79.DT delay ex.)	79M Auto Recl.	OUT	on	*		*	LED			BO					
2754	>79: Dead Time Start Delay (>79 DT St.Delay)	79M Auto Recl.	SP	On Off	*		*	LED	BI		BO					
2781	79 Auto recloser is switched OFF (79 OFF)	79M Auto Recl.	OUT	on	*		*	LED			BO	40	81	1	Yes	
2782	79 Auto recloser is switched ON (79 ON)	79M Auto Recl.	IntSP	On Off	*		*	LED			BO	160	16	1	Yes	
2784	79 Auto recloser is NOT ready (79 is NOT ready)	79M Auto Recl.	OUT	On Off	*		*	LED			BO	160	130	1	Yes	
2785	79 - Auto-reclose is dynamically BLOCKED (79 DynBlock)	79M Auto Recl.	OUT	On Off	on		*	LED			BO	40	85	1	Yes	
2788	79: CB ready monitoring window expired (79 T-CBreadyExp)	79M Auto Recl.	OUT	on	*		*	LED			BO					

No.	Description	Function	Type of Information	Log Buffers				Configurable in Matrix					IEC 60870-5-103		
				Event Log ON/OFF	Trip (Fault) Log ON/OFF	Ground Fault Log ON/OFF	Marked in Oscill. Record	LED	Binary Input	Function Key	Relay	Chatter Suppression	Type	Information Number	Data Unit
2801	79 - in progress (79 in progress)	79M Auto Recl.	OUT	*	on		*	LED			BO	40	101	2	Yes
2808	79: CB open with no trip (79 BLK: CB open)	79M Auto Recl.	OUT	On Off	*		*	LED			BO				
2809	79: Start-signal monitoring time expired (79 T-Start Exp)	79M Auto Recl.	OUT	on	*		*	LED			BO				
2810	79: Maximum dead time expired (79 TdeadMax Exp)	79M Auto Recl.	OUT	on	*		*	LED			BO				
2823	79: no starter configured (79 no starter)	79M Auto Recl.	OUT	On Off	*		*	LED			BO				
2824	79: no cycle configured (79 no cycle)	79M Auto Recl.	OUT	On Off	*		*	LED			BO				
2827	79: blocking due to trip (79 BLK by trip)	79M Auto Recl.	OUT	on	*		*	LED			BO				
2828	79: blocking due to 3-phase pickup (79 BLK:3ph p.u.)	79M Auto Recl.	OUT	on	*		*	LED			BO				
2829	79: action time expired before trip (79 Tact expired)	79M Auto Recl.	OUT	on	*		*	LED			BO				
2830	79: max. no. of cycles exceeded (79 Max. No. Cyc)	79M Auto Recl.	OUT	on	*		*	LED			BO				
2844	79 1st cycle running (79 1stCyc. run.)	79M Auto Recl.	OUT	*	on		*	LED			BO				
2845	79 2nd cycle running (79 2ndCyc. run.)	79M Auto Recl.	OUT	*	on		*	LED			BO				
2846	79 3rd cycle running (79 3rdCyc. run.)	79M Auto Recl.	OUT	*	on		*	LED			BO				
2847	79 4th or higher cycle running (79 4thCyc. run.)	79M Auto Recl.	OUT	*	on		*	LED			BO				
2851	79 - Close command (79 Close)	79M Auto Recl.	OUT	*	on		m	LED			BO	160	128	2	No
2862	79 - cycle successful (79 Successful)	79M Auto Recl.	OUT	on	on		*	LED			BO	40	162	1	Yes
2863	79 - Lockout (79 Lockout)	79M Auto Recl.	OUT	on	on		*	LED			BO	40	163	2	Yes
2865	79: Synchro-check request (79 Sync.Request)	79M Auto Recl.	OUT	*	on		*	LED			BO				
2878	79-A/R single phase reclosing sequence (79 L-N Sequence)	79M Auto Recl.	OUT	*	on		*	LED			BO	40	180	2	Yes
2879	79-A/R multi-phase reclosing sequence (79 L-L Sequence)	79M Auto Recl.	OUT	*	on		*	LED			BO	40	181	2	Yes
2883	Zone Sequencing is active (ZSC active)	79M Auto Recl.	OUT	On Off	on		*	LED			BO				
2884	Zone sequence coordination switched ON (ZSC ON)	79M Auto Recl.	OUT	on	*		*	LED			BO				
2885	Zone sequence coordination switched OFF (ZSC OFF)	79M Auto Recl.	OUT	on	*		*	LED			BO				
2889	79 1st cycle zone extension release (79 1.CycZoneRel)	79M Auto Recl.	OUT	*	*		*	LED			BO				
2890	79 2nd cycle zone extension release (79 2.CycZoneRel)	79M Auto Recl.	OUT	*	*		*	LED			BO				
2891	79 3rd cycle zone extension release (79 3.CycZoneRel)	79M Auto Recl.	OUT	*	*		*	LED			BO				
2892	79 4th cycle zone extension release (79 4.CycZoneRel)	79M Auto Recl.	OUT	*	*		*	LED			BO				
2896	No. of 1st AR-cycle CLOSE commands,3pole (79 #Close1./3p=)	Statistics	VI												
2898	No. of higher AR-cycle CLOSE commands,3p (79 #Close2./3p=)	Statistics	VI												

No.	Description	Function	Type of Information	Log Buffers				Configurable in Matrix					IEC 60870-5-103				
				Event Log ON/OFF	Trip (Fault) Log ON/OFF	Ground Fault Log ON/OFF	Marked in Oscill. Record	LED	Binary Input	Function Key	Relay	Chatter Suppression	Type	Information Number	Data Unit	General Interrogation	
2899	79: Close request to Control Function (79 CloseRequest)	79M Auto Recl.	OUT	*	on		*	LED			BO						
4601	>52-a contact (OPEN, if bkr is open) (>52-a)	P.System Data 2	SP	On Off	*		*	LED	BI		BO						
4602	>52-b contact (OPEN, if bkr is closed) (>52-b)	P.System Data 2	SP	On Off	*		*	LED	BI		BO						
4822	>BLOCK Motor Startup counter (>BLOCK 66)	48/66 Motorprot	SP	*	*		*	LED	BI		BO						
4823	>Emergency start (>66 emer.start)	48/66 Motorprot	SP	On Off	*		*	LED	BI		BO	168	51	1	Yes		
4824	66 Motor start protection OFF (66 OFF)	48/66 Motorprot	OUT	On Off	*		*	LED			BO	168	52	1	Yes		
4825	66 Motor start protection BLOCKED (66 BLOCKED)	48/66 Motorprot	OUT	On Off	On Off		*	LED			BO	168	53	1	Yes		
4826	66 Motor start protection ACTIVE (66 ACTIVE)	48/66 Motorprot	OUT	On Off	*		*	LED			BO	168	54	1	Yes		
4827	66 Motor start protection TRIP (66 TRIP)	48/66 Motorprot	OUT	On Off	*		*	LED			BO	168	55	1	Yes		
4828	>66 Reset thermal memory (>66 RM th.repl.)	48/66 Motorprot	SP	On Off	*		*	LED	BI		BO						
4829	66 Reset thermal memory (66 RM th.repl.)	48/66 Motorprot	OUT	On Off	*		*	LED			BO						
4834	66 Rotor overload TRIP (66 OVERL. TRIP)	48/66 Motorprot	OUT	on	on		*	LED			BO						
4835	66 Rotor Overload Alarm (66 OVERL.ALARM)	48/66 Motorprot	OUT	On Off	*		*	LED			BO						
5143	>BLOCK 46 (>BLOCK 46)	46 Negative Seq	SP	*	*		*	LED	BI		BO	70	126	1	Yes		
5145	>Reverse Phase Rotation (>Reverse Rot.)	P.System Data 1	SP	On Off	*		*	LED	BI		BO						
5147	Phase rotation ABC (Rotation ABC)	P.System Data 1	OUT	On Off	*		*	LED			BO	70	128	1	Yes		
5148	Phase rotation ACB (Rotation ACB)	P.System Data 1	OUT	On Off	*		*	LED			BO	70	129	1	Yes		
5151	46 switched OFF (46 OFF)	46 Negative Seq	OUT	On Off	*		*	LED			BO	70	131	1	Yes		
5152	46 is BLOCKED (46 BLOCKED)	46 Negative Seq	OUT	On Off	On Off		*	LED			BO	70	132	1	Yes		
5153	46 is ACTIVE (46 ACTIVE)	46 Negative Seq	OUT	On Off	*		*	LED			BO	70	133	1	Yes		
5159	46-2 picked up (46-2 picked up)	46 Negative Seq	OUT	*	On Off		*	LED			BO	70	138	2	Yes		
5165	46-1 picked up (46-1 picked up)	46 Negative Seq	OUT	*	On Off		*	LED			BO	70	150	2	Yes		
5166	46-TOC picked up (46-TOC pickedup)	46 Negative Seq	OUT	*	On Off		*	LED			BO	70	141	2	Yes		
5170	46 TRIP (46 TRIP)	46 Negative Seq	OUT	*	on		m	LED			BO	70	149	2	Yes		
5171	46 Disk emulation picked up (46 Dsk pickedup)	46 Negative Seq	OUT	*	*		*	LED			BO						
5951	>BLOCK 50 1Ph (>BLK 50 1Ph)	50 1Ph	SP	*	*		*	LED	BI		BO						
5952	>BLOCK 50 1Ph-1 (>BLK 50 1Ph-1)	50 1Ph	SP	*	*		*	LED	BI		BO						
5953	>BLOCK 50 1Ph-2 (>BLK 50 1Ph-2)	50 1Ph	SP	*	*		*	LED	BI		BO						
5961	50 1Ph is OFF (50 1Ph OFF)	50 1Ph	OUT	On Off	*		*	LED			BO						

No.	Description	Function	Type of Information	Log Buffers				Configurable in Matrix					IEC 60870-5-103				
				Event Log ON/OFF	Trip (Fault) Log ON/OFF	Ground Fault Log ON/OFF	Marked in Oscill. Record	LED	Binary Input	Function Key	Relay	Chatter Suppression	Type	Information Number	Data Unit	General Interrogation	
5962	50 1Ph is BLOCKED (50 1Ph BLOCKED)	50 1Ph	OUT	On Off	On Off		*	LED			BO						
5963	50 1Ph is ACTIVE (50 1Ph ACTIVE)	50 1Ph	OUT	On Off	*		*	LED			BO						
5966	50 1Ph-1 is BLOCKED (50 1Ph-1 BLK)	50 1Ph	OUT	On Off	On Off		*	LED			BO						
5967	50 1Ph-2 is BLOCKED (50 1Ph-2 BLK)	50 1Ph	OUT	On Off	On Off		*	LED			BO						
5971	50 1Ph picked up (50 1Ph Pickup)	50 1Ph	OUT	*	On Off		*	LED			BO						
5972	50 1Ph TRIP (50 1Ph TRIP)	50 1Ph	OUT	*	on		*	LED			BO						
5974	50 1Ph-1 picked up (50 1Ph-1 PU)	50 1Ph	OUT	*	On Off		*	LED			BO						
5975	50 1Ph-1 TRIP (50 1Ph-1 TRIP)	50 1Ph	OUT	*	on		*	LED			BO						
5977	50 1Ph-2 picked up (50 1Ph-2 PU)	50 1Ph	OUT	*	On Off		*	LED			BO						
5979	50 1Ph-2 TRIP (50 1Ph-2 TRIP)	50 1Ph	OUT	*	on		*	LED			BO						
5980	50 1Ph: 1 at pick up (50 1Ph I:)	50 1Ph	VI	*	On Off												
6801	>BLOCK Startup Supervision (>BLK START-SUP)	48/66 Motorprot	SP	*	*		*	LED	BI		BO						
6805	>Rotor locked (>Rotor locked)	48/66 Motorprot	SP	*	*		*	LED	BI		BO						
6811	Startup supervision OFF (START-SUP OFF)	48/66 Motorprot	OUT	On Off	*		*	LED			BO	169	51	1	Yes		
6812	Startup supervision is BLOCKED (START-SUP BLK)	48/66 Motorprot	OUT	On Off	On Off		*	LED			BO	169	52	1	Yes		
6813	Startup supervision is ACTIVE (START-SUP ACT)	48/66 Motorprot	OUT	On Off	*		*	LED			BO	169	53	1	Yes		
6821	Startup supervision TRIP (START-SUP TRIP)	48/66 Motorprot	OUT	*	on		m	LED			BO	169	54	2	Yes		
6822	Rotor locked (Rotor locked)	48/66 Motorprot	OUT	*	on		*	LED			BO	169	55	2	Yes		
6823	Startup supervision Pickup (START-SUP pu)	48/66 Motorprot	OUT	On Off	*		*	LED			BO	169	56	1	Yes		
6851	>BLOCK 74TC (>BLOCK 74TC)	74TC TripCirc.	SP	*	*		*	LED	BI		BO						
6852	>74TC Trip circuit superv.: trip relay (>74TC trip rel.)	74TC TripCirc.	SP	On Off	*		*	LED	BI		BO	170	51	1	Yes		
6853	>74TC Trip circuit superv.: bkr relay (>74TC brk rel.)	74TC TripCirc.	SP	On Off	*		*	LED	BI		BO	170	52	1	Yes		
6861	74TC Trip circuit supervision OFF (74TC OFF)	74TC TripCirc.	OUT	On Off	*		*	LED			BO	170	53	1	Yes		
6862	74TC Trip circuit supervision is BLOCKED (74TC BLOCKED)	74TC TripCirc.	OUT	On Off	On Off		*	LED			BO	153	16	1	Yes		
6863	74TC Trip circuit supervision is ACTIVE (74TC ACTIVE)	74TC TripCirc.	OUT	On Off	*		*	LED			BO	153	17	1	Yes		
6864	74TC blocked. Bin. input is not set (74TC ProgFail)	74TC TripCirc.	OUT	On Off	*		*	LED			BO	170	54	1	Yes		
6865	74TC Failure Trip Circuit (74TC Trip cir.)	74TC TripCirc.	OUT	On Off	*		*	LED			BO	170	55	1	Yes		
6903	>block interm. E/F prot. (>IEF block)	Intermit. EF	SP	*	*		*	LED	BI		BO	152	1	1	Yes		
6921	Interm. E/F prot. is switched off (IEF OFF)	Intermit. EF	OUT	On Off	*		*	LED			BO	152	10	1	Yes		
6922	Interm. E/F prot. is blocked (IEF blocked)	Intermit. EF	OUT	On Off	On Off		*	LED			BO	152	11	1	Yes		

No.	Description	Function	Type of Information	Log Buffers				Configurable in Matrix					IEC 60870-5-103			
				Event Log ON/OFF	Trip (Fault) Log ON/OFF	Ground Fault Log ON/OFF	Marked in Oscill. Record	LED	Binary Input	Function Key	Relay	Chatter Suppression	Type	Information Number	Data Unit	General Interrogation
6923	Interm. E/F prot. is active (IEF enabled)	Intermit. EF	OUT	On Off	*		*	LED			BO	152	12	1	Yes	
6924	Interm. E/F detection stage lie> (IIE Fault det)	Intermit. EF	OUT	*	*		*	LED			BO					
6925	Interm. E/F stab detection (IIE stab.Flt)	Intermit. EF	OUT	*	*		*	LED			BO					
6926	Interm.E/F det.stage lie> f.Flt.ev.Prot (IIE Flt.det FE)	Intermit. EF	OUT	*	on		*					152	13	2	No	
6927	Interm. E/F detected (Intermitt.EF)	Intermit. EF	OUT	*	On Off		*	LED			BO	152	14	2	Yes	
6928	Counter of det. times elapsed (IEF Tsum exp.)	Intermit. EF	OUT	*	on		*	LED			BO	152	15	2	No	
6929	Interm. E/F: reset time running (IEF Tres run.)	Intermit. EF	OUT	*	On Off		*	LED			BO	152	16	2	Yes	
6930	Interm. E/F: trip (IEF Trip)	Intermit. EF	OUT	*	on		*	LED			BO	152	17	2	No	
6931	Max RMS current value of fault = (IIE/IIn=)	Intermit. EF	VI		On Off		*					152	18	4	No	
6932	No. of detections by stage IIE>= (Nos.IIE=)	Intermit. EF	VI		On Off		*					152	19	4	No	
7551	50-1 InRush picked up (50-1 InRushPU)	50/51 Overcur.	OUT	*	On Off		*	LED			BO	60	80	2	Yes	
7552	50N-1 InRush picked up (50N-1 InRushPU)	50/51 Overcur.	OUT	*	On Off		*	LED			BO	60	81	2	Yes	
7553	51 InRush picked up (51 InRush-PU)	50/51 Overcur.	OUT	*	On Off		*	LED			BO	60	82	2	Yes	
7554	51N InRush picked up (51N InRushPU)	50/51 Overcur.	OUT	*	On Off		*	LED			BO	60	83	2	Yes	
7556	InRush OFF (InRush OFF)	50/51 Overcur.	OUT	On Off	*		*	LED			BO	60	92	1	Yes	
7557	InRush BLOCKED (InRush BLK)	50/51 Overcur.	OUT	On Off	On Off		*	LED			BO	60	93	1	Yes	
7558	InRush Ground detected (InRush Gnd Det)	50/51 Overcur.	OUT	*	On Off		*	LED			BO	60	94	2	Yes	
7563	>BLOCK InRush (>BLOCK InRush)	50/51 Overcur.	SP	*	*		*	LED	BI		BO					
7564	Ground InRush picked up (Gnd InRush PU)	50/51 Overcur.	OUT	*	On Off		*	LED			BO	60	88	2	Yes	
7565	Phase A InRush picked up (Ia InRush PU)	50/51 Overcur.	OUT	*	On Off		*	LED			BO	60	89	2	Yes	
7566	Phase B InRush picked up (Ib InRush PU)	50/51 Overcur.	OUT	*	On Off		*	LED			BO	60	90	2	Yes	
7567	Phase C InRush picked up (Ic InRush PU)	50/51 Overcur.	OUT	*	On Off		*	LED			BO	60	91	2	Yes	
10020	>BLOCK Load Jam Protection (>BLOCK Jam Prot)	48/66 Motorprot	SP	On Off				LED	BI		BO					
10021	Load Jam Protection is BLOCKED (JAM PROT.BLOCK.)	48/66 Motorprot	OUT	On Off				LED			BO					
10022	Load Jam Protection is OFF (JAM PROT.OFF)	48/66 Motorprot	OUT	On Off				LED			BO					
10023	Load Jam Protection is ACTIVE (JAM PROT.ACTIVE)	48/66 Motorprot	OUT	On Off				LED			BO					
10024	Load Jam Protection alarm (Load Jam alarm)	48/66 Motorprot	OUT	On Off			*	LED			BO					
10025	Load Jam Protection picked up (Load Jam pickup)	48/66 Motorprot	OUT		On Off		*	LED			BO					

No.	Description	Function	Type of Information	Log Buffers				Configurable in Matrix					IEC 60870-5-103				
				Event Log ON/OFF	Trip (Fault) Log ON/OFF	Ground Fault Log ON/OFF	Marked in Oscill. Record	LED	Binary Input	Function Key	Relay	Chatter Suppression	Type	Information Number	Data Unit	General Interrogation	
10026	Load Jam Protection TRIP (Load Jam TRIP)	48/66 Motorprot	OUT		On Off		*	LED			BO						
10027	Startup Duration 1 (StartDuration1)	Mot.Statistics	VI														
10028	Startup Current 1 (StartupCurrent1)	Mot.Statistics	VI														
10029	Startup Voltage 1 (StartupVoltage1)	Mot.Statistics	VI														
10030	Total Number of Motor Starts (Nr.of Mot.Start)	Mot.Statistics	VI														
10031	Total Motor Running Time (Motor Run.Time)	Mot.Statistics	VI														
10032	Total Motor Stopped Time (Motor Stop.Time)	Mot.Statistics	VI														
10033	Motor Percent Running Time (Perc.Run.Time)	Mot.Statistics	VI														
10034	50-3 BLOCKED (50-3 BLOCKED)	50/51 Overcur.	OUT	On Off	On Off		*	LED			BO						
10035	50N-3 BLOCKED (50N-3 BLOCKED)	50/51 Overcur.	OUT	On Off	On Off		*	LED			BO						
10037	Startup Duration 2 (StartDuration2)	Mot.Statistics	VI														
10038	Startup Current 2 (StartupCurrent2)	Mot.Statistics	VI														
10039	Startup Voltage 2 (StartupVoltage2)	Mot.Statistics	VI														
10040	Startup Duration 3 (StartDuration3)	Mot.Statistics	VI														
10041	Startup Current 3 (StartupCurrent3)	Mot.Statistics	VI														
10042	Startup Voltage 3 (StartupVoltage3)	Mot.Statistics	VI														
10043	Startup Duration 4 (StartDuration4)	Mot.Statistics	VI														
10044	Startup Current 4 (StartupCurrent4)	Mot.Statistics	VI														
10045	Startup Voltage 4 (StartupVoltage4)	Mot.Statistics	VI														
10046	Startup Duration 5 (StartDuration5)	Mot.Statistics	VI														
10047	Startup Current 5 (StartupCurrent5)	Mot.Statistics	VI														
10048	Startup Voltage 5 (StartupVoltage5)	Mot.Statistics	VI														
14101	Fail: RTD (broken wire/shorted) (Fail: RTD)	RTD-Box	OUT	On Off	*		*	LED			BO						
14111	Fail: RTD 1 (broken wire/shorted) (Fail: RTD 1)	RTD-Box	OUT	On Off	*		*	LED			BO						
14112	RTD 1 Temperature stage 1 picked up (RTD 1 St.1 p.up)	RTD-Box	OUT	On Off	*		*	LED			BO						
14113	RTD 1 Temperature stage 2 picked up (RTD 1 St.2 p.up)	RTD-Box	OUT	On Off	*		*	LED			BO						
14121	Fail: RTD 2 (broken wire/shorted) (Fail: RTD 2)	RTD-Box	OUT	On Off	*		*	LED			BO						
14122	RTD 2 Temperature stage 1 picked up (RTD 2 St.1 p.up)	RTD-Box	OUT	On Off	*		*	LED			BO						

No.	Description	Function	Type of Information	Log Buffers				Configurable in Matrix				IEC 60870-5-103		
				Event Log ON/OFF	Trip (Fault) Log ON/OFF	Ground Fault Log ON/OFF	Marked in Oscill. Record	LED	Binary Input	Function Key	Relay	Chatter Suppression	Type	Information Number
14123	RTD 2 Temperature stage 2 picked up (RTD 2 St.2 p.up)	RTD-Box	OUT	On Off	*		*	LED			BO			
14131	Fail: RTD 3 (broken wire/shorted) (Fail: RTD 3)	RTD-Box	OUT	On Off	*		*	LED			BO			
14132	RTD 3 Temperature stage 1 picked up (RTD 3 St.1 p.up)	RTD-Box	OUT	On Off	*		*	LED			BO			
14133	RTD 3 Temperature stage 2 picked up (RTD 3 St.2 p.up)	RTD-Box	OUT	On Off	*		*	LED			BO			
14141	Fail: RTD 4 (broken wire/shorted) (Fail: RTD 4)	RTD-Box	OUT	On Off	*		*	LED			BO			
14142	RTD 4 Temperature stage 1 picked up (RTD 4 St.1 p.up)	RTD-Box	OUT	On Off	*		*	LED			BO			
14143	RTD 4 Temperature stage 2 picked up (RTD 4 St.2 p.up)	RTD-Box	OUT	On Off	*		*	LED			BO			
14151	Fail: RTD 5 (broken wire/shorted) (Fail: RTD 5)	RTD-Box	OUT	On Off	*		*	LED			BO			
14152	RTD 5 Temperature stage 1 picked up (RTD 5 St.1 p.up)	RTD-Box	OUT	On Off	*		*	LED			BO			
14153	RTD 5 Temperature stage 2 picked up (RTD 5 St.2 p.up)	RTD-Box	OUT	On Off	*		*	LED			BO			
14161	Fail: RTD 6 (broken wire/shorted) (Fail: RTD 6)	RTD-Box	OUT	On Off	*		*	LED			BO			
14162	RTD 6 Temperature stage 1 picked up (RTD 6 St.1 p.up)	RTD-Box	OUT	On Off	*		*	LED			BO			
14163	RTD 6 Temperature stage 2 picked up (RTD 6 St.2 p.up)	RTD-Box	OUT	On Off	*		*	LED			BO			
14171	Fail: RTD 7 (broken wire/shorted) (Fail: RTD 7)	RTD-Box	OUT	On Off	*		*	LED			BO			
14172	RTD 7 Temperature stage 1 picked up (RTD 7 St.1 p.up)	RTD-Box	OUT	On Off	*		*	LED			BO			
14173	RTD 7 Temperature stage 2 picked up (RTD 7 St.2 p.up)	RTD-Box	OUT	On Off	*		*	LED			BO			
14181	Fail: RTD 8 (broken wire/shorted) (Fail: RTD 8)	RTD-Box	OUT	On Off	*		*	LED			BO			
14182	RTD 8 Temperature stage 1 picked up (RTD 8 St.1 p.up)	RTD-Box	OUT	On Off	*		*	LED			BO			
14183	RTD 8 Temperature stage 2 picked up (RTD 8 St.2 p.up)	RTD-Box	OUT	On Off	*		*	LED			BO			
14191	Fail: RTD 9 (broken wire/shorted) (Fail: RTD 9)	RTD-Box	OUT	On Off	*		*	LED			BO			
14192	RTD 9 Temperature stage 1 picked up (RTD 9 St.1 p.up)	RTD-Box	OUT	On Off	*		*	LED			BO			
14193	RTD 9 Temperature stage 2 picked up (RTD 9 St.2 p.up)	RTD-Box	OUT	On Off	*		*	LED			BO			
14201	Fail: RTD10 (broken wire/shorted) (Fail: RTD10)	RTD-Box	OUT	On Off	*		*	LED			BO			
14202	RTD10 Temperature stage 1 picked up (RTD10 St.1 p.up)	RTD-Box	OUT	On Off	*		*	LED			BO			
14203	RTD10 Temperature stage 2 picked up (RTD10 St.2 p.up)	RTD-Box	OUT	On Off	*		*	LED			BO			
14211	Fail: RTD11 (broken wire/shorted) (Fail: RTD11)	RTD-Box	OUT	On Off	*		*	LED			BO			
14212	RTD11 Temperature stage 1 picked up (RTD11 St.1 p.up)	RTD-Box	OUT	On Off	*		*	LED			BO			
14213	RTD11 Temperature stage 2 picked up (RTD11 St.2 p.up)	RTD-Box	OUT	On Off	*		*	LED			BO			

No.	Description	Function	Type of Information	Log Buffers				Configurable in Matrix					IEC 60870-5-103				
				Event Log ON/OFF	Trip (Fault) Log ON/OFF	Ground Fault Log ON/OFF	Marked in Oscill. Record	LED	Binary Input	Function Key	Relay	Chatter Suppression	Type	Information Number	Data Unit	General Interrogation	
14221	Fail: RTD12 (broken wire/shorted) (Fail: RTD12)	RTD-Box	OUT	On Off	*		*	LED				BO					
14222	RTD12 Temperature stage 1 picked up (RTD12 St.1 p.up)	RTD-Box	OUT	On Off	*		*	LED				BO					
14223	RTD12 Temperature stage 2 picked up (RTD12 St.2 p.up)	RTD-Box	OUT	On Off	*		*	LED				BO					
16001	Sum Current Exponentiation Ph A to Ir^x ($\Sigma I^x A=$)	Statistics	VI														
16002	Sum Current Exponentiation Ph B to Ir^x ($\Sigma I^x B=$)	Statistics	VI														
16003	Sum Current Exponentiation Ph C to Ir^x ($\Sigma I^x C=$)	Statistics	VI														
16005	Threshold Sum Curr. Exponent. exceeded (Threshold $\Sigma I^x >$)	SetPoint(Stat)	OUT	On Off	*		*	LED				BO					
16006	Residual Endurance Phase A (Resid.Endu. A=)	Statistics	VI														
16007	Residual Endurance Phase B (Resid.Endu. B=)	Statistics	VI														
16008	Residual Endurance Phase C (Resid.Endu. C=)	Statistics	VI														
16010	Dropped below Threshold CB Res.Endurance (Thresh.R.Endu.<)	SetPoint(Stat)	OUT	On Off	*		*	LED				BO					
16011	Number of mechanical Trips Phase A (mechan.TRIP A=)	Statistics	VI														
16012	Number of mechanical Trips Phase B (mechan.TRIP B=)	Statistics	VI														
16013	Number of mechanical Trips Phase C (mechan.TRIP C=)	Statistics	VI														
16014	Sum Squared Current Integral Phase A ($\Sigma I^2t A=$)	Statistics	VI														
16015	Sum Squared Current Integral Phase B ($\Sigma I^2t B=$)	Statistics	VI														
16016	Sum Squared Current Integral Phase C ($\Sigma I^2t C=$)	Statistics	VI														
16018	Threshold Sum Squa. Curr. Int. exceeded (Thresh. $\Sigma I^2t >$)	SetPoint(Stat)	OUT	On Off	*		*	LED				BO					
16019	>52 Breaker Wear Start Criteria (>52 Wear start)	P.System Data 2	SP	On Off	*		*	LED	BI			BO					
16020	52 Wear blocked by Time Setting Failure (52 WearSet.fail)	P.System Data 2	OUT	On Off	*		*	LED				BO					
16027	52 Breaker Wear Logic blk Ir-CB=>Isc-CB (52WL.blk I PErr)	P.System Data 2	OUT	On Off	*		*	LED				BO					
16028	52 Breaker W.Log.blk SwCyc.Isc>=SwCyc.Ir (52WL.blk n PErr)	P.System Data 2	OUT	On Off	*		*	LED				BO					
16029	Sens.gnd.fit. 51Ns BLOCKED Setting Error (51Ns BLK PaErr)	Sens. Gnd Fault	OUT	On Off	*		*	LED				BO					
30053	Fault recording is running (Fault rec. run.)	Osc. Fault Rec.	OUT	*	*		*	LED				BO					
31000	Q0 operationcounter= (Q0 OpCnt=)	Control Device	VI	*													
31001	Q1 operationcounter= (Q1 OpCnt=)	Control Device	VI	*													
31002	Q2 operationcounter= (Q2 OpCnt=)	Control Device	VI	*													

No.	Description	Function	Type of Information	Log Buffers				Configurable in Matrix					IEC 60870-5-103				
				Event Log ON/OFF	Trip (Fault) Log ON/OFF	Ground Fault Log ON/OFF	Marked in Oscill. Record	LED	Binary Input	Function Key	Relay	Chatter Suppression	Type	Information Number	Data Unit	General Interrogation	
31008	Q8 operationcounter= (Q8 OpCnt=)	Control Device	VI	*													
31009	Q9 operationcounter= (Q9 OpCnt=)	Control Device	VI	*													

A.10 Group Alarms

No.	Description	Function No.	Description
140	Error Sum Alarm	144 145 146 147 177 178 183 184 185 186 187 188 189 191 193	Error 5V Error 0V Error -5V Error PwrSupply Fail Battery I/O-Board error Error Board 1 Error Board 2 Error Board 3 Error Board 4 Error Board 5 Error Board 6 Error Board 7 Error Offset Alarm NO calibr
160	Alarm Sum Event	162 163 175 264 267	Failure Σ I Fail I balance Fail Ph. Seq. I Fail: RTD-Box 1 Fail: RTD-Box 2
161	Fail I Superv.	162 163	Failure Σ I Fail I balance

A.11 Measured Values

No.	Description	Function	IEC 60870-5-103					Configurable in Matrix		
			Type	Information Number	Compatibility	Data Unit	Position	CFC	Control Display	Default Display
-	I A dmd> (I Admd>)	Set Points(MV)	-	-	-	-	-	CFC	CD	DD
-	I B dmd> (I Bdmd>)	Set Points(MV)	-	-	-	-	-	CFC	CD	DD
-	I C dmd> (I Cdmd>)	Set Points(MV)	-	-	-	-	-	CFC	CD	DD
-	I1dmd> (I1dmd>)	Set Points(MV)	-	-	-	-	-	CFC	CD	DD
-	37-1 under current (37-1)	Set Points(MV)	-	-	-	-	-	CFC	CD	DD
-	Number of TRIPs= (#of TRIPs=)	Statistics	-	-	-	-	-	CFC	CD	DD
-	Operating hours greater than (OpHour>)	SetPoint(Stat)	-	-	-	-	-	CFC	CD	DD
601	Ia (Ia =)	Measurement	134	137	No	9	1	CFC	CD	DD
602	Ib (Ib =)	Measurement	160	144	Yes	3	1	CFC	CD	DD
			134	137	No	9	2			
603	Ic (Ic =)	Measurement	134	137	No	9	3	CFC	CD	DD
604	In (In =)	Measurement	134	137	No	9	4	CFC	CD	DD
605	I1 (positive sequence) (I1 =)	Measurement	-	-	-	-	-	CFC	CD	DD
606	I2 (negative sequence) (I2 =)	Measurement	-	-	-	-	-	CFC	CD	DD
661	Threshold of Restart Inhibit (Θ REST. =)	Measurement	-	-	-	-	-	CFC	CD	DD
805	Temperature of Rotor (Θ Rotor)	Measurement	-	-	-	-	-	CFC	CD	DD
807	Thermal Overload (Θ/Θ trip)	Measurement	-	-	-	-	-	CFC	CD	DD
809	Time untill release of reclose-blocking (T reclose=)	Measurement	-	-	-	-	-	CFC	CD	DD
830	INs Sensitive Ground Fault Current (INs =)	Measurement	-	-	-	-	-	CFC	CD	DD
831	3I0 (zero sequence) (3I0 =)	Measurement	-	-	-	-	-	CFC	CD	DD
833	I1 (positive sequence) Demand (I1 dmd=)	Demand meter	-	-	-	-	-	CFC	CD	DD
837	I A Demand Minimum (IAdmdMin)	Min/Max meter	-	-	-	-	-	CFC	CD	DD
838	I A Demand Maximum (IAdmdMax)	Min/Max meter	-	-	-	-	-	CFC	CD	DD
839	I B Demand Minimum (IBdmdMin)	Min/Max meter	-	-	-	-	-	CFC	CD	DD
840	I B Demand Maximum (IBdmdMax)	Min/Max meter	-	-	-	-	-	CFC	CD	DD
841	I C Demand Minimum (ICdmdMin)	Min/Max meter	-	-	-	-	-	CFC	CD	DD
842	I C Demand Maximum (ICdmdMax)	Min/Max meter	-	-	-	-	-	CFC	CD	DD
843	I1 (positive sequence) Demand Minimum (I1dmdMin)	Min/Max meter	-	-	-	-	-	CFC	CD	DD
844	I1 (positive sequence) Demand Maximum (I1dmdMax)	Min/Max meter	-	-	-	-	-	CFC	CD	DD
851	Ia Min (Ia Min=)	Min/Max meter	-	-	-	-	-	CFC	CD	DD
852	Ia Max (Ia Max=)	Min/Max meter	-	-	-	-	-	CFC	CD	DD
853	Ib Min (Ib Min=)	Min/Max meter	-	-	-	-	-	CFC	CD	DD
854	Ib Max (Ib Max=)	Min/Max meter	-	-	-	-	-	CFC	CD	DD
855	Ic Min (Ic Min=)	Min/Max meter	-	-	-	-	-	CFC	CD	DD
856	Ic Max (Ic Max=)	Min/Max meter	-	-	-	-	-	CFC	CD	DD
857	I1 (positive sequence) Minimum (I1 Min=)	Min/Max meter	-	-	-	-	-	CFC	CD	DD
858	I1 (positive sequence) Maximum (I1 Max=)	Min/Max meter	-	-	-	-	-	CFC	CD	DD
888	Pulsed Energy Wp (active) (Wp(puls))	Energy	133	55	No	205	-	CFC	CD	DD
889	Pulsed Energy Wq (reactive) (Wq(puls))	Energy	133	56	No	205	-	CFC	CD	DD
963	I A demand (Ia dmd=)	Demand meter	-	-	-	-	-	CFC	CD	DD
964	I B demand (Ib dmd=)	Demand meter	-	-	-	-	-	CFC	CD	DD
965	I C demand (Ic dmd=)	Demand meter	-	-	-	-	-	CFC	CD	DD

No.	Description	Function	IEC 60870-5-103					Configurable in Matrix		
			Type	Information Number	Compatibility	Data Unit	Position	CFC	Control Display	Default Display
1058	Overload Meter Max ($\Theta/\Theta_{TrpMax}=\)$)	Min/Max meter	-	-	-	-	-	CFC	CD	DD
1059	Overload Meter Min ($\Theta/\Theta_{TrpMin}=\)$)	Min/Max meter	-	-	-	-	-	CFC	CD	DD
1068	Temperature of RTD 1 (Θ RTD 1 =)	Measurement	134	146	No	9	1	CFC	CD	DD
1069	Temperature of RTD 2 (Θ RTD 2 =)	Measurement	134	146	No	9	2	CFC	CD	DD
1070	Temperature of RTD 3 (Θ RTD 3 =)	Measurement	134	146	No	9	3	CFC	CD	DD
1071	Temperature of RTD 4 (Θ RTD 4 =)	Measurement	134	146	No	9	4	CFC	CD	DD
1072	Temperature of RTD 5 (Θ RTD 5 =)	Measurement	134	146	No	9	5	CFC	CD	DD
1073	Temperature of RTD 6 (Θ RTD 6 =)	Measurement	134	146	No	9	6	CFC	CD	DD
1074	Temperature of RTD 7 (Θ RTD 7 =)	Measurement	134	146	No	9	7	CFC	CD	DD
1075	Temperature of RTD 8 (Θ RTD 8 =)	Measurement	134	146	No	9	8	CFC	CD	DD
1076	Temperature of RTD 9 (Θ RTD 9 =)	Measurement	134	146	No	9	9	CFC	CD	DD
1077	Temperature of RTD10 (Θ RTD10 =)	Measurement	134	146	No	9	10	CFC	CD	DD
1078	Temperature of RTD11 (Θ RTD11 =)	Measurement	134	146	No	9	11	CFC	CD	DD
1079	Temperature of RTD12 (Θ RTD12 =)	Measurement	134	146	No	9	12	CFC	CD	DD
16004	Threshold Sum Current Exponentiation ($\Sigma I^x >$)	SetPoint(Stat)	-	-	-	-	-	CFC	CD	DD
16009	Lower Threshold of CB Residual Endurance (Resid.Endu. <)	SetPoint(Stat)	-	-	-	-	-	CFC	CD	DD
16017	Threshold Sum Squared Current Integral ($\Sigma I^2 t >$)	SetPoint(Stat)	-	-	-	-	-	CFC	CD	DD
16032	In2 (ln2 =)	Measurement	-	-	-	-	-	CFC	CD	DD

■

www.ElectricalPartManuals.com

Literature

- /1/ SIPROTEC 4 System Description; E50417-H1140-C151-A8
- /2/ SIPROTEC DIGSI, Start UP; E50417-G1176-C152-A2
- /3/ DIGSI CFC, Manual; E50417-H1140-C098-A7
- /4/ SIPROTEC SIGRA 4, Manual; E50417-H1176-C070-A4
- /5/ Additional Information on the Protection of Explosion-Protected Motors of Protection Type "e"; C53000-B1174-C158

www.ElectricalPartManuals.com

Glossary

Battery

The buffer battery ensures that specified data areas, flags, timers and counters are retained retentively.

Bay controllers

Bay controllers are devices with control and monitoring functions without protective functions.

Bit pattern indication

Bit pattern indication is a processing function by means of which items of digital process information applying across several inputs can be detected together in parallel and processed further. The bit pattern length can be specified as 1, 2, 3 or 4 bytes.

BP_xx

→ Bit pattern indication (Bitstring Of x Bit), x designates the length in bits (8, 16, 24 or 32 bits).

C_xx

Command without feedback

CF_xx

Command with feedback

CFC

Continuous Function Chart. CFC is a graphics editor with which a program can be created and configured by using ready-made blocks.

CFC blocks

Blocks are parts of the user program delimited by their function, their structure or their purpose.

Chatter blocking

A rapidly intermittent input (for example, due to a relay contact fault) is switched off after a configurable monitoring time and can thus not generate any further signal changes. The function prevents overloading of the system when a fault arises.

Combination devices

Combination devices are bay devices with protection functions and a control display.

Combination matrix

DIGSI V4.6 and higher allows up to 32 compatible SIPROTEC 4 devices to communicate with each other in an inter-relay communication network (IRC). The combination matrix defines which devices exchange which information.

Communication branch

A communications branch corresponds to the configuration of 1 to n users which communicate by means of a common bus.

Communication reference CR

The communication reference describes the type and version of a station in communication by PROFIBUS.

Component view

In addition to a topological view, SIMATIC Manager offers you a component view. The component view does not offer any overview of the hierarchy of a project. It does, however, provide an overview of all the SIPROTEC 4 devices within a project.

COMTRADE

Common Format for Transient Data Exchange, format for fault records.

Container

If an object can contain other objects, it is called a container. The object Folder is an example of such a container.

Control display

The image which is displayed on devices with a large (graphic) display after pressing the control key is called control display. It contains the switchgear that can be controlled in the feeder with status display. It is used to perform switching operations. Defining this diagram is part of the configuration.

Data pane

→ The right-hand area of the project window displays the contents of the area selected in the → navigation window, for example indications, measured values, etc. of the information lists or the function selection for the device configuration.

DCF77

The extremely precise official time is determined in Germany by the "Physikalisch-Technischen-Bundesanstalt PTB" in Braunschweig. The atomic clock unit of the PTB transmits this time via the long-wave time-signal transmitter in Mainflingen near Frankfurt/Main. The emitted time signal can be received within a radius of approx. 1,500 km from Frankfurt/Main.

Device container

In the Component View, all SIPROTEC 4 devices are assigned to an object of type Device container. This object is a special object of DIGSI Manager. However, since there is no component view in DIGSI Manager, this object only becomes visible in conjunction with STEP 7.

Double command

Double commands are process outputs which indicate 4 process states at 2 outputs: 2 defined (for example ON/OFF) and 2 undefined states (for example intermediate positions)

Double-point indication

Double-point indications are items of process information which indicate 4 process states at 2 inputs: 2 defined (for example ON/OFF) and 2 undefined states (for example intermediate positions).

DP

→ Double-point indication

DP_I

→ Double point indication, intermediate position 00

Drag-and-drop

Copying, moving and linking function, used at graphics user interfaces. Objects are selected with the mouse, held and moved from one data area to another.

Electromagnetic compatibility

Electromagnetic compatibility (EMC) is the ability of an electrical apparatus to function fault-free in a specified environment without influencing the environment unduly.

EMC

→ Electromagnetic compatibility

ESD protection

ESD protection is the total of all the means and measures used to protect electrostatic sensitive devices.

ExBPxx

External bit pattern indication via an ETHERNET connection, device-specific → Bit pattern indication

ExC

External command without feedback via an ETHERNET connection, device-specific

ExCF

External command with feedback via an ETHERNET connection, device-specific

ExDP

External double point indication via an ETHERNET connection, device-specific → Double-point indication

ExDP_I

External double-point indication via an ETHERNET connection, intermediate position 00, → Double-point indication

ExMV

External metered value via an ETHERNET connection, device-specific

ExSI

External single-point indication via an ETHERNET connection, device-specific → Single-point indication

ExSI_F

External single point indication via an ETHERNET connection, device-specific, → Fleeting indication, → Single-point indication

Field devices

Generic term for all devices assigned to the field level: Protection devices, combination devices, bay controllers.

Floating

→ Without electrical connection to the → ground.

FMS communication branch

Within an FMS communication branch the users communicate on the basis of the PROFIBUS FMS protocol via a PROFIBUS FMS network.

Folder

This object type is used to create the hierarchical structure of a project.

General interrogation (GI)

During the system start-up the state of all the process inputs, of the status and of the fault image is sampled. This information is used to update the system-end process image. The current process state can also be sampled after a data loss by means of a GI.

GOOSE message

GOOSE messages (Generic Object Oriented Substation Event) in accordance with IEC 61850 are data packages that are transmitted cyclically and event-controlled via the Ethernet communication system. They serve for direct information exchange among the relays. This mechanism facilitates cross-communication between bay devices.

GPS

Global Positioning System. Satellites with atomic clocks on board orbit the earth twice a day in different parts in approx. 20,000 km. They transmit signals which also contain the GPS universal time. The GPS receiver determines its own position from the signals received. From its position it can derive the running time of a satellite and thus correct the transmitted GPS universal time.

Ground

The conductive ground whose electric potential can be set equal to zero in any point. In the area of ground electrodes the ground can have a potential deviating from zero. The term "Ground reference plane" is often used for this state.

Grounding

Grounding means that a conductive part is to connect via a grounding system to → ground.

Grounding

Grounding is the total of all means and measured used for grounding.

Hierarchy level

Within a structure with higher-level and lower-level objects a hierarchy level is a container of equivalent objects.

HV field description

The HV project description file contains details of fields which exist in a ModPara project. The actual field information of each field is memorized in a HV field description file. Within the HV project description file, each field is allocated such a HV field description file by a reference to the file name.

HV project description

All data are exported once the configuration and parameterization of PCUs and sub-modules using ModPara has been completed. This data is split up into several files. One file contains details about the fundamental project structure. This also includes, for example, information detailing which fields exist in this project. This file is called a HV project description file.

ID

Internal double-point indication → Double-point indication

ID_S

Internal double point indication intermediate position 00 → Double-point indication

IEC

International Electrotechnical Commission

IEC Address

Within an IEC bus a unique IEC address has to be assigned to each SIPROTEC 4 device. A total of 254 IEC addresses are available for each IEC bus.

IEC communication branch

Within an IEC communication branch the users communicate on the basis of the IEC60-870-5-103 protocol via an IEC bus.

IEC61850

Worldwide communication standard for communication in substations. This standard allows devices from different manufacturers to interoperate on the station bus. Data transfer is accomplished through an Ethernet network.

Initialization string

An initialization string comprises a range of modem-specific commands. These are transmitted to the modem within the framework of modem initialization. The commands can, for example, force specific settings for the modem.

Inter relay communication

→ IRC combination

IRC combination

Inter Relay Communication, IRC, is used for directly exchanging process information between SIPROTEC 4 devices. You require an object of type IRC combination to configure an Inter Relay Communication. Each user of the combination and all the necessary communication parameters are defined in this object. The type and scope of the information exchanged among the users is also stored in this object.

IRIG-B

Time signal code of the Inter-Range Instrumentation Group

IS

Internal single-point indication → Single-point indication

IS_F

Internal indication fleeting → Fleeting indication, → Single-point indication

ISO 9001

The ISO 9000 ff range of standards defines measures used to ensure the quality of a product from the development to the manufacturing.

Link address

The link address gives the address of a V3/V2 device.

List view

The right pane of the project window displays the names and icons of objects which represent the contents of a container selected in the tree view. Because they are displayed in the form of a list, this area is called the list view.

LV

Limit value

LVU

Limit value, user-defined

Master

Masters may send data to other users and request data from other users. DIGSI operates as a master.

Metered value

Metered values are a processing function with which the total number of discrete similar events (counting pulses) is determined for a period, usually as an integrated value. In power supply companies the electrical work is usually recorded as a metered value (energy purchase/supply, energy transportation).

MLFB

MLFB is the acronym of "MaschinenLesbare FabrikateBezeichnung" (machine-readable product designation). It is equivalent to the order number. The type and version of a SIPROTEC 4 device are coded in the order number.

Modem connection

This object type contains information on both partners of a modem connection, the local modem and the remote modem.

Modem profile

A modem profile consists of the name of the profile, a modem driver and may also comprise several initialization commands and a user address. You can create several modem profiles for one physical modem. To do so you need to link various initialization commands or user addresses to a modem driver and its properties and save them under different names.

Modems

Modem profiles for a modem connection are saved in this object type.

MV

Measured value

MVMV

Metered value which is formed from the measured value

MVT

Measured value with time

MVU

Measured value, user-defined

Navigation pane

The left pane of the project window displays the names and symbols of all containers of a project in the form of a folder tree.

Object

Each element of a project structure is called an object in DIGSI.

Object properties

Each object has properties. These might be general properties that are common to several objects. An object can also have specific properties.

Off-line

In offline mode a link with the SIPROTEC 4 device is not necessary. You work with data which are stored in files.

OI_F

Output indication fleeting → Transient information

On-line

When working in online mode, there is a physical link to a SIPROTEC 4 device which can be implemented in various ways. This link can be implemented as a direct connection, as a modem connection or as a PROFIBUS FMS connection.

OUT

Output indication

Parameter set

The parameter set is the set of all parameters that can be set for a SIPROTEC 4 device.

Phone book

User addresses for a modem connection are saved in this object type.

PMV

Pulse metered value

Process bus

Devices featuring a process bus interface can communicate directly with the SICAM HV modules. The process bus interface is equipped with an Ethernet module.

PROFIBUS

PROcess Field BUS, the German process and field bus standard, as specified in the standard EN 50170, Volume 2, PROFIBUS. It defines the functional, electrical, and mechanical properties for a bit-serial field bus.

PROFIBUS Address

Within a PROFIBUS network a unique PROFIBUS address has to be assigned to each SIPROTEC 4 device. A total of 254 PROFIBUS addresses are available for each PROFIBUS network.

Project

Content-wise, a project is the image of a real power supply system. Graphically, a project is represented by a number of objects which are integrated in a hierarchical structure. Physically, a project consists of a series of folders and files containing project data.

Protection devices

All devices with a protective function and no control display.

Reorganizing

Frequent addition and deletion of objects creates memory areas that can no longer be used. By cleaning up projects, you can release these memory areas. However, a clean up also reassigns the VD addresses. As a consequence, all SIPROTEC 4 devices need to be reinitialized.

RIO file

Relay data Interchange format by Omicron.

RSxxx-interface

Serial interfaces RS232, RS422/485

SCADA Interface

Rear serial interface on the devices for connecting to a control system via IEC or PROFIBUS.

Service port

Rear serial interface on the devices for connecting DIGSI (for example, via modem).

Setting parameters

General term for all adjustments made to the device. Parameterization jobs are executed by means of DIGSI or, in some cases, directly on the device.

SI

→ Single point indication

SI_F

→ Single-point indication fleeting → Transient information, → Single-point indication

SICAM SAS

Modular substation automation system based on the substation controller → SICAM SC and the SICAM WinCC operator control and monitoring system.

SICAM SC

Substation Controller. Modularly substation control system, based on the SIMATIC M7 automation system.

SICAM WinCC

The SICAM WinCC operator control and monitoring system displays the condition of your network graphically, visualizes alarms and indications, archives the network data, allows to intervene manually in the process and manages the system rights of the individual employee.

Single command

Single commands are process outputs which indicate 2 process states (for example, ON/OFF) at one output.

Single point indication

Single indications are items of process information which indicate 2 process states (for example, ON/OFF) at one output.

SIPROTEC

The registered trademark SIPROTEC is used for devices implemented on system base V4.

SIPROTEC 4 device

This object type represents a real SIPROTEC 4 device with all the setting values and process data it contains.

SIPROTEC 4 variant

This object type represents a variant of an object of type SIPROTEC 4 device. The device data of this variant may well differ from the device data of the source object. However, all variants derived from the source object have the same VD address as the source object. For this reason, they always correspond to the same real SIPROTEC 4 device as the source object. Objects of type SIPROTEC 4 variant have a variety of uses, such as documenting different operating states when entering parameter settings of a SIPROTEC 4 device.

Slave

A slave may only exchange data with a master after being prompted to do so by the master. SIPROTEC 4 devices operate as slaves.

Time stamp

Time stamp is the assignment of the real time to a process event.

Topological view

DIGSI Manager always displays a project in the topological view. This shows the hierarchical structure of a project with all available objects.

Transformer Tap Indication

Transformer tap indication is a processing function on the DI by means of which the tap of the transformer tap changer can be detected together in parallel and processed further.

Transient information

A transient information is a brief transient → single-point indication at which only the coming of the process signal is detected and processed immediately.

Tree view

The left pane of the project window displays the names and symbols of all containers of a project in the form of a folder tree. This area is called the tree view.

TxTap

→ Transformer Tap Indication

User address

A user address comprises the name of the station, the national code, the area code and the user-specific phone number.

Users

DIGSI V4.6 and higher allows up to 32 compatible SIPROTEC 4 devices to communicate with each other in an inter-relay communication network. The individual participating devices are called users.

VD

A VD (Virtual Device) includes all communication objects and their properties and states that are used by a communication user through services. A VD can be a physical device, a module of a device or a software module.

VD address

The VD address is assigned automatically by DIGSI Manager. It exists only once in the entire project and thus serves to identify unambiguously a real SIPROTEC 4 device. The VD address assigned by DIGSI Manager must be transferred to the SIPROTEC 4 device in order to allow communication with DIGSI Device Editor.

VFD

A VFD (Virtual Field Device) includes all communication objects and their properties and states that are used by a communication user through services.

VI

Value Indication

www.ElectricalPartManuals.com

Index

4

46-1, 46-2 94

A

Action Time 165
Alternating Voltage 307
Ambient temperature 125
Analog Inputs 306
ATEX100 111, 126
Automatic Reclosing Function 162
Automatic Reclosing System 79 351
Automatic Reclosure 162
Auxiliary Voltage 262, 266, 306

B

Binary Inputs 307
Binary Outputs 307
Blocking Time 166
Breaker Control 365
Breaker Failure Protection 185
Breaker Failure Protection 50BF 352
Buffer Battery 134
Busbar Protection 87
Busbar protection 92

C

Certifications 317
Changing Setting Groups 43
Check: Circuit Breaker Failure Protection 296
Check: Connection of the Currents 298
Check: Phase Rotation 298
Check: Switching States of the Binary Inputs and Outputs 293
Check: Temperature Measurement 299
Check: Tripping/Closing for the Configured Operating Devices 301
Checking: Operator Interface 285
Checking: Service Interface 285
Checking: System (SCADA) interface 286
Checking: System Connections 288

Checking: Termination 286
Checking: Time Synchronization Interface 287
Checking: User-Defined Functions 297
Circuit Breaker Maintenance 363
Circuit Breaker Monitoring 169
Circuit Breaker Status Recognition 168
Climatic Stress Tests 316
Clock 363
Commissioning Aids 363
Communication Interfaces 309
Construction: Panel Surface Mounting 284
Contact Mode for Binary Outputs 263
Control Voltage 266, 273, 275
Control Voltage for Binary Inputs 263
Control voltage of BI 1 to BI 3 266
Control Voltage of BI4 to BI11 273, 275
Controlling Protection Elements 170
Coolant temperature 125
Cross Blocking 59
CT
 Knee-point voltage 90
CTS (Clear to Send) 278
Cubicle mounting 283
Current Balance Monitoring 135
Current Inputs 306
Current Symmetry Monitoring 137
Current Transformer
 Knee-point Voltage 85

D

DC Voltage 306
Dead Time Start Delay 165
Default Display Selection
 Start Page 32
Definite-Time Overcurrent Protection 50 (N) 318
Design 317
Dynamic Blocking 167
Dynamic Cold Load Pickup 332
Dynamic Cold Load Pickup Function 77

- E**
- Electrical Tests 313
 - EMC Tests for Immunity (Type Tests) 313
 - EMC Tests For Noise Emission (Type Test) 314
 - Emergency Start 111
 - EN100 Module
 - Interface Selection 47
 - Equilibrium Time 109
- F**
- Fault Display
 - Setting Instructions 32
 - Fault Event Recording 362
 - Fault Recording 41, 362
 - Fiber-optic Cables 287
 - Final Preparation of the Device 303
 - Flexible Protection Functions 353
 - Flow Control (CTS) 278
 - Function Modules 356
 - Functional Scope 28
- G**
- General Device Pickup 211
 - General tripping 212
 - Ground Fault 85, 86
 - Ground fault 91
 - Ground Fault Protection 50N(s), 51N(s) 346
 - Group Switchover of the Function Parameters 364
- H**
- Hardware Monitoring 134
 - High-impedance differential protection
 - Sensitivity 90
 - Stability conditions 89
 - High-impedance protection 88
 - Hours Meter "CB open" 216
 - Humidity 316
- I**
- Inrush Restraint 58
 - Insulation Test 313
 - Interlocked Switching 248
 - Intermittent Ground Fault Protection 156, 350
 - Inverse Time Overcurrent Protection 55
 - Inverse-Time Overcurrent Protection 51 (N) 320
- L**
- Limits for CFC blocks 358
 - Limits for User-defined Functions 358
 - Load Jam Protection 343
 - Local Measured Values Monitoring 362
 - Long-Term Averages 361
- M**
- Malfunction Responses of the Monitoring Functions 144
 - Measurement Supervision 134
 - Mechanical Stress Tests 315
 - Min / Max report 361
 - Minimum Inhibit Time 109
 - Monitoring of the Circuit Breaker Auxiliary Contacts 187
 - Monitoring of the Current Flow 186
 - Motor Restart Inhibit 66 342
 - Motor Starting Protection 48 341
- N**
- Negative Sequence Protection 46-1, 46-2 334
 - Negative Sequence Protection 46-TOC 335
 - Nominal Currents 262
 - Non-Interlocked Switching 248
- O**
- Offset Monitoring 136
 - Operating Hours Counter 363
 - Operating Interface 309
 - Operational Measured Values 355, 361
 - Ordering Information 370
 - Output Relays Binary Outputs 308
 - Overcurrent Protection
 - Single-phase 88, 333
 - Overcurrent Protection 50, 51, 50N, 51N
 - Pickup value 92
 - Time Delay 88
 - Overcurrent Protection Earth Current
 - Frequency 333
 - Overcurrent Protection single-phase
 - Current Elements 333
 - Frequency 333, 333
 - Overload protection 124
- P**
- Panel Flush and Cubicle Mounting 366
 - Panel Surface Mounting 367
 - Phase rotation 209

Pickup logic 211
Power System Data 1 35

R

Rack mounting 283
Reclosing Programs 165
Recordings for Tests 302
Replacing Interfaces 263
Restart Threshold 109
Restart Time 109
Reverse Interlocking Busbar Protection 62
Rotor Overload Detection 109
RTD Boxes for Temperature Detection 200
RTD-Box 287

S

Sensitive ground fault detection 147
Service / Modem Interface 309
Service Conditions 316
Setting Groups: Changing; Changing of Setting Groups 258
Software Monitoring 136
Standard Interlocking 249
Standards 313
Static Blocking 167
Supply Voltage 306
Switching Authority 252
Switching mode 253
Switching Statistics 362
System Interface 310

T

Tank Leakage Protection 87
Tank leakage protection
 Delay time 92
 Sensitivity 92
Temperature Detection 200
Temperature Detection via RTD Boxes 355
Temperature Detectors 355
Temperatures 316
Terminating the Trip Signal 212
Termination 286
Termination of Bus-capable Interfaces 263
Test: System Interface 291
Thermal Overload Protection 49 344
Thermal replica 124
Thresholds for Temperature Indications 355
Time Allocation 362
Time Overcurrent Protection 48

Time overcurrent protection
 Pickup value 88
 Transformer data 88
Time Overcurrent Protection 50, 51, 50N, 51N
 Time Delay 92
Time Synchronization 363
Time Synchronization Interface 287, 312
Total Time 110
Transformer
 Knee-point Voltage 86
Triggering Oscillographic Recording 302
Trip Circuit Monitoring 363
Trip Circuit Supervision 259
Trip circuit supervision 140
Trip/Close Tests for the Configured Operating Devices 301
Tripping Logic 212
Tripping Test with Circuit Breaker 301
Two-phase Time Overcurrent Protection 62

U

User-defined Functions 356

V

Vibration and Shock Stress during Stationary Operation 315
Vibration and Shock Stress during Transport 315
Voltage Limit 87
Voltage Supply 306

W

Watchdog 136
Web Monitor 237

www . ElectricalPartManuals . com