

**SIEMENS**

# **SAMMS™**

Siemens Advanced Motor  
Master System

Custom Software Manual

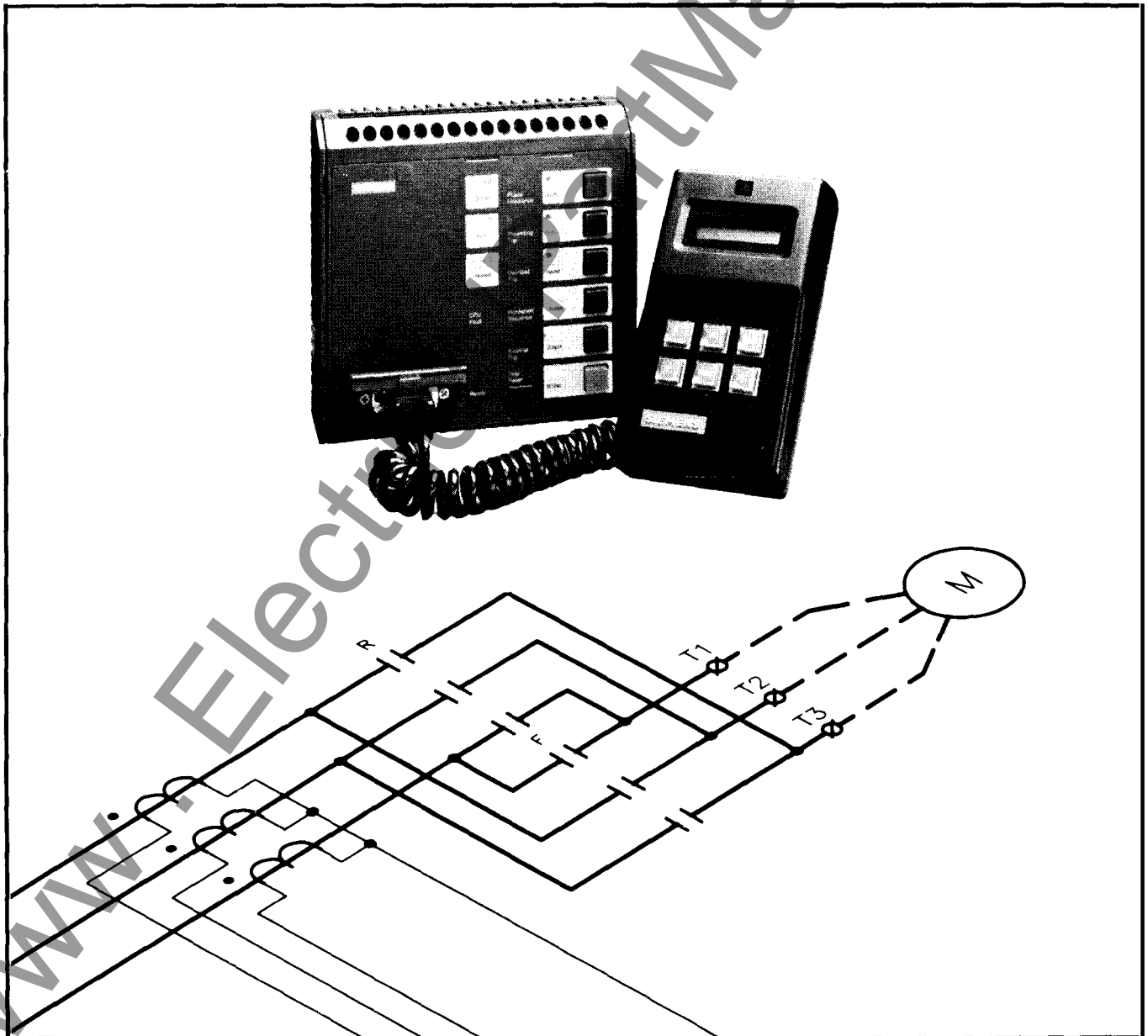

© 1991 Siemens Energy & Automation, Inc. All Rights Reserved.

SAMMS is a trademark of Siemens Energy & Automation, Inc.  
IBM, Personal System/2, PC AT and AT are registered trademarks and XT is a trademark of International Business Machines Corporation.  
MS-DOS is a registered trademark of Microsoft Corporation.  
OrCAD is a registered trademark of OrCAD, L.P.  
All other brand and product names appearing in this manual are registered trademarks, trademarks or trade names of their respective holders.

'DIRECT ACCESS' is a trademark of Delta Technology International.  
All rights assigned to Fifth Generation Systems, Inc., Baton Rouge, LA

The information contained herein does not relieve the user of responsibility to use sound practice in application, installation, operation, and maintenance of the equipment purchased. Siemens reserves the right to make changes in the information shown herein or to make improvements at any time without notice or obligations.

## **About This Manual**

Welcome to SAMMS Custom Software Manual. This manual contains the information you need for designing custom ladder diagrams and downloading and programming the memory of the SAMMS device with the custom ladder.

All the commands and features of the SAMMS premium software package are covered in detail, along with a variety of examples and illustrations. You may also use this manual if you choose the standard or the backup software package.

But this manual does more. It explains in intricate detail the logic used in developing several of the SAMMS standard ladder diagrams, so that you can use this logic to customize one of the existing 70 standard ladder diagrams or to create one-of-a-kind ladder diagrams to meet your requirements.

In addition to this manual, you should have on hand copies of the SAMMS Standard Circuit Manual and the SAMMS Technical Reference Manual to use as references.

## **How to use this manual**

How you should start using this manual depends on what you want to do and what you already know about motor control circuits and about the SAMMS device.

As a minimum, you should be familiar with the rules and the symbols used in the creation and editing of ladder diagrams before starting to use your software package. For this information refer to the SAMMS Standard Circuits Manual.

Then see section 1 of this manual for rung by rung and contact by contact description of the operation and the logic used on a large number of control circuits varying in difficulty from a simple across-the-line to a more complicated wye-delta ladder diagram.

Then refer to section 2 of this manual for step by step instruction on how to use your software to draw or to modify a ladder diagram on the screen of your computer and how to download this diagram from your computer to your SAMMS.

# Contents

## Section 1

<b>Introduction .....</b>	<b>1-1</b>
<b>Symbols .....</b>	<b>1-1</b>
<b>Output Devices .....</b>	<b>1-1</b>
Outputs .....	1-1
Control Relays .....	1-1
Timing Relays .....	1-1
Pilot LEDs .....	1-1
Flashing Pilot LEDs .....	1-1
<b>Input Devices .....</b>	<b>1-4</b>
Remote Inputs .....	1-4
Front Panel Pushbuttons .....	1-4
Software Auxiliary Contacts .....	1-4
Software Timer Inputs .....	1-4
Communications Inputs .....	1-4
General Rules .....	1-5
<b>Examples of Ladder Diagrams .....</b>	<b>1-6</b>
Example 1, across-the-line, non-reversing, remote three-wire .....	1-6
Example 2, across-the-line, reversing, local three-wire/ remote three-wire .....	1-10
Example 3, two-speed, two-winding, local three-wire/ remote two-wire .....	1-14
Example 4, two-speed, one-winding, constant horsepower, local two-wire .....	1-18
Example 5, two-speed, one-winding, constant or variable torque, local two-wire .....	1-20
Example 6, part-winding, remote three-wire .....	1-22
Example 7, wye-delta, open-transition, remote three-wire .....	1-24
Example 8, reduced-voltage, autotransformer, (NEMA sizes 5 and 6), remote three-wire .....	1-26
Example 9, reduced-voltage, autotransformer, (NEMA sizes 2-4), remote three-wire .....	1-28
Example 10, wye-delta, closed-transition, remote three-wire .	1-30
Example 11, two-speed, one-winding, constant horsepower, local two-wire .....	1-32
Example 12, two-speed, one-winding, constant horsepower, (direct transition from low- to high-speed), local two-wire .....	1-34

## Section 1: Custom Ladder Diagrams

### 1. Introduction

The Siemens Advanced Motor Master System (SAMMS) can be configured to perform many motor starting and control functions, from basic across-the-line to more complicated reversing, two-speed, and reduced-voltage starting. The process of configuring the MCC for a given application entails: 1) the definition of the contactors and remote control elements external to the SAMMS, including their assignment to specific SAMMS outputs and inputs and their external interconnection; 2) the definition and assignment of SAMMS front-panel pushbuttons and light bars; 3) the definition and assignment of timers; 4) a ladder diagram representing the chosen control function; 5) the generation of corresponding operating code for the microcomputer in the SAMMS; and, 6) the downloading and programming of the memory of the SAMMS with the operating code.

A software package was written to help the user through process steps 1-6. The software, which runs on a standard IBM™ PC/AT, takes advantage of the flexibility of the microcomputer-based SAMMS in handling many control applications by permitting the user to build custom ladders according to his needs.

### 2. Symbols

Before attempting to build a custom ladder, the user should familiarize himself with symbols representing the input and output devices available in the SAMMS. The ladder symbols are shown in Figure 1. The circular symbols represent output devices such as contactor coil drivers, pilot LEDs on the front panel of the SAMMS, software time-delay relays, and software control relays. All other symbols represent input devices such as software auxiliary contacts, remote inputs, front-panel pushbuttons, and software timer instantaneous and timed contacts.

### 3. Output Devices

#### 3.1 Outputs

Three ac coil drivers capable of driving contactors up to NEMA size 6 are available in the SAMMS.

#### 3.2 Control Relays

Eight software control relays are available and are especially helpful in local two-wire and other applications requiring maintained contacts.

#### 3.3 Timing Relays

Four software timing relays are available. All four of the timers can be configured as on-delay timers; only the two adjustable timers can be configured as either on-delay or off-delay timers. Timing relays TR1 and TR2 are the adjustable timers. Their delays can be set by the handheld unit for any delay from 0 through 200s. Timing relay TR3 is fixed for a 1s delay; timing relay TR4 is fixed for a 30s delay.

#### 3.4 Pilot LEDs

Three light bars on the front panel of the SAMMS are available. Light bar L1 is normally used as the STOP LED. Light bars L2 and L3 can be configured at the user's discretion. HAND/OFF/AUTO LEDs corresponding to the HAND/OFF/AUTO pushbuttons on the front panel are also available. The Incomplete Sequence LED is also available for use in reduced-voltage applications.

#### 3.5 Flashing Pilot LEDs

Three flashing light bars are available to indicate various conditions, such as on-delay timing. In actuality, light bars L1-L3 are the flashing LEDs, but through a SAMMS software trick, they are treated as different output devices for a flashing condition than for a constantly on condition, thereby removing the flashing rate timer from the ladder diagram.

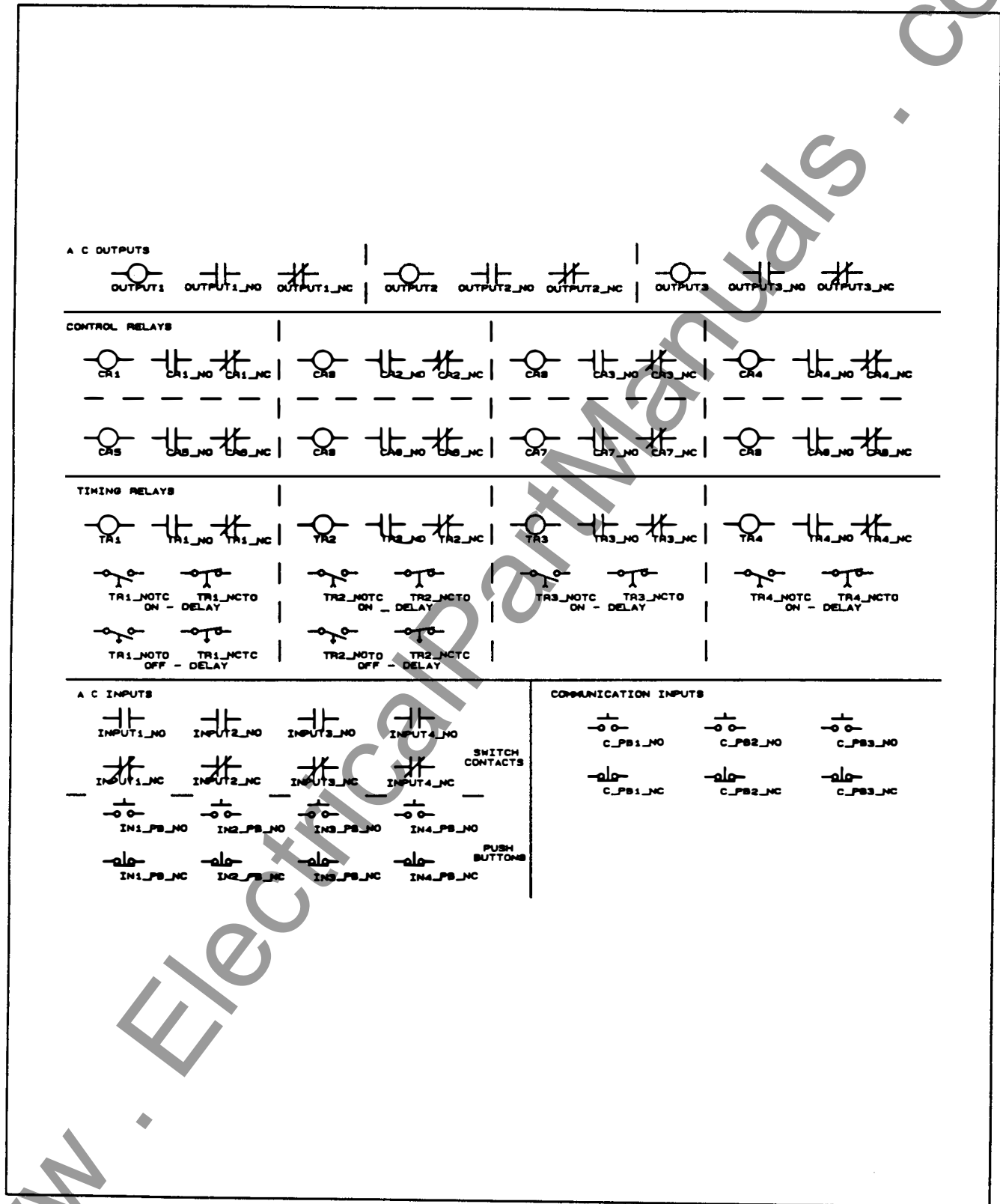

Figure 1. Ladder Symbols - Part 1

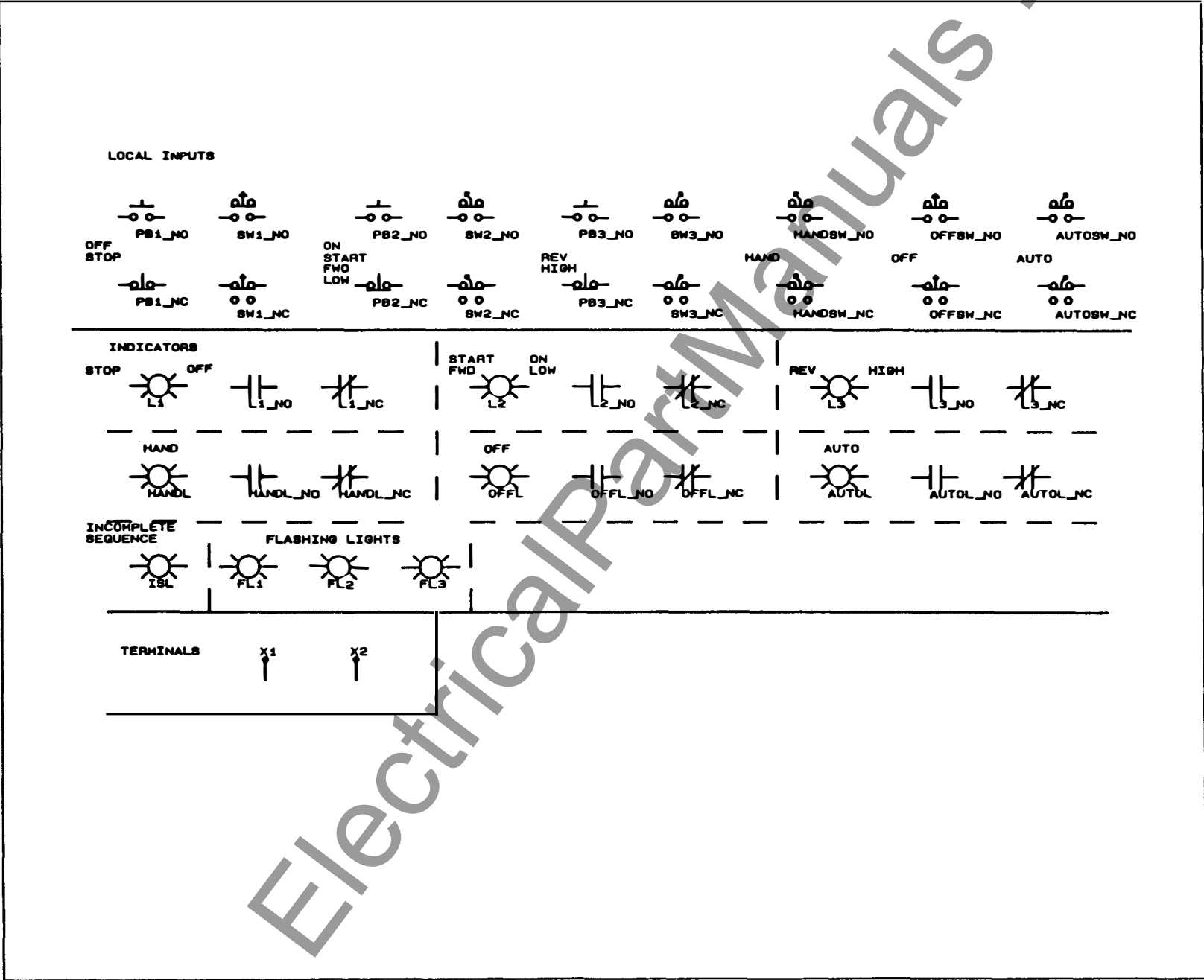

Figure 1. Ladder Symbols - Part 2

relay CR1 is energized. When TR1 is first energized, NO contact instantly closes. NCTO contact TR1 remains closed until timeout. If NO contact CR1 is closed, indicating a forward command, FL2 is energized and the FWD light bar is caused to flash. Upon TR1's timeout, NCTO contact TR1 opens and stops the flashing. Rung 8 operates analogously for the REV light bar.

This page left blank for your notes.

www.ElectricalPartManuals.com

#### 6.4 Example 4

##### Starter type:

two-speed, one-winding, constant horsepower

##### Control type:

local two-wire

##### Front-panel pushbuttons:

SW1 (OFF)

SW2 (LOW)

SW3 (HIGH)

##### Front-panel light bars:

L1 (STOP)

L2 (LOW)

L3 (HIGH)

##### Remote inputs:

none

##### Output:

OUTPUT1 (motor low)

OUTPUT2 (motor high)

OUTPUT3 (wye configuration for low)

##### Timers:

TR1 (on-delay)

TR2 (low lockout delay after stop from high)

##### Flashing light bars:

FL2 (during on delay low)

FL3 (during on delay high)

Figure 6 is the ladder diagram for the example. The first two rungs latch the input commands in control relays CR1 and CR2. Rung 1 latches in the low command with control relay CR1. NC timing relay contact TR2 locks out low input commands while timer TR2 is timing. The low pushbutton command (SW2 NO) is latched in with parallel auxiliary contact CR1. Series-connected NC contact CR2, which is open while high speed is selected, prevents direct transitions from high- to low-speed operation. When depressed, the STOP pushbutton (SW1 NC) de-energizes CR1.

Control relay CR2 in rung 2 latches in the local high pushbutton (SW3) with parallel seal-in contact CR2. Series-connected NC contact CR1 ensures that the

low-speed winding connections release before the high-speed connection is made. The STOP button (SW1) performs the same function for high control as they do for low control as described in rung 1. The NC TR2 contact of rung 1 is absent from rung 2 because the lockout delay locks out low speed only.

Rung 3 in Figure 6 controls on-delay timer TR1 in the same way as rung 3 in Figure 5 for Example 3, except that control relays CR1 and CR2 only are used for the local-only control of this example. Rung 4 is identical to rung 4 of Figure 5, except that only the NC CR2 contact is required for the local-only controls. Timing relay TR2 is energized upon stopping the motor from high. While TR2 times, low input commands are locked out by the NC contact TR2 in rung 1. Upon timing out, TR2 is de-energized by the opening of its NCTO contact TR2 in rung 4.

The low- and high-speed connections are controlled by coil drivers OUTPUT1, OUTPUT2, and OUTPUT3 as shown in rungs 12, 5, and 6. After a high or a low input command is given, on-delay timer TR1 starts to time. When TR1 times out, NOTC contact TR1 in rungs 12, 5, and 6 closes. If high is selected, NO contact CR2 in rung 6 is closed energizing coil driver OUTPUT2, which connects the motor windings in delta for high-speed operation. NO control relay CR1 is open, de-energizing coil drivers OUTPUT1 and OUTPUT3, which connect the motor for low-speed operation. If, on the other hand, low is selected, NO contact CR2 is open and NO contact CR1 is closed. As soon as timer TR1 times out, coil driver OUTPUT3 is energized, connecting the motor windings in parallel wye. After the auxiliary contact of OUTPUT3 closes (about 30 ms later), the OUTPUT1 coil driver of rung 12 is energized, connecting the parallel-wye motor winding to the line for low-speed operation.

Rungs 9-11 control the illumination of light bars L1-3 just as rungs 9-11 in Figure 5. The flashing of the LOW and HIGH light bars FL2 and FL3 is controlled by rungs 7 and 8 as described by rungs 7 and 8 in Figure 5, except that the CR3 and CR4 relays are not needed for the local-only operation of this example.

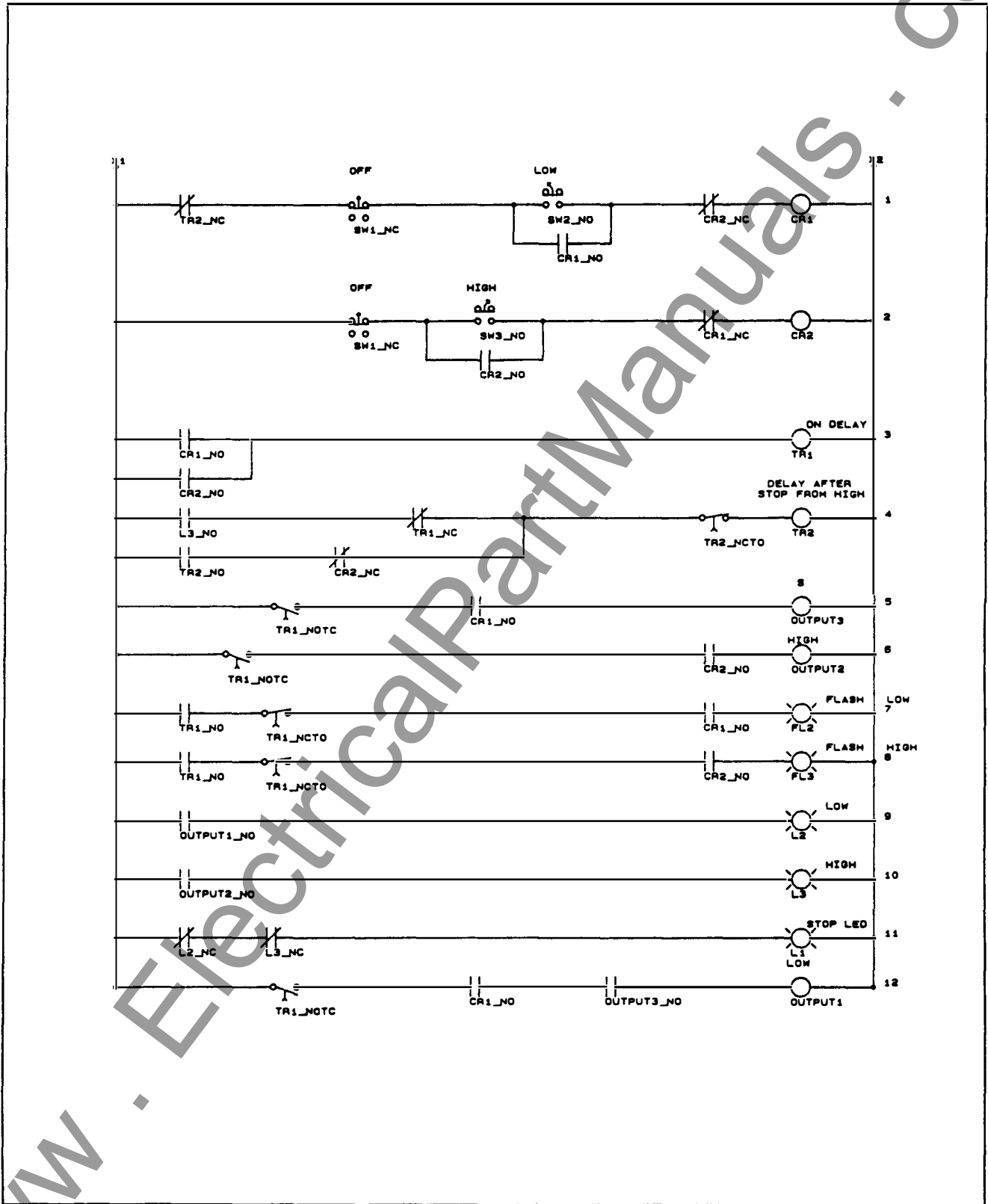

Figure 6. Ladder Diagram: Two Speed, one-winding, constant horsepower, local two-wire

**6.8 Example 8****Starter type:**

reduced-voltage, autotransformer  
(NEMA sizes 5 and 6)

**Control type:**

remote three-wire

**Front-panel pushbuttons:**

none

**Front-panel light bars:**

L1 (STOP)

L2 (RUN)

**Remote inputs:**

INPUT1 (STOP)

INPUT2 (START)

INPUT4 (R NC)

**Output:**

OUTPUT1 (1S - shorting start contactor)

OUTPUT2 (R - run contactor)

OUTPUT3 (2S - start contactor)

**Timers:**

TR1 (on-delay)

TR3 (incomplete sequence timer - 1s)

TR4 (start-to-run transition - 30s)

**Flashing light bars:**

FL2 (during on delay)

The first two rungs of Figure 10 are identical to those of Figure 9. The sequencing of the motor during start-up is controlled by rungs 3-6. When on-delay timer TR1 times out after a start command, its NOTC contact TR1 in rungs 3-6 closes. Transition timer TR4 is energized and starts to time. The 1S shorting contactor is closed by coil driver OUTPUT1, which is energized through NCTO contact TR4 and NC contact OUTPUT2 in rung 4. When the auxiliary NO contact of OUTPUT1 closes about 30ms later, coil driver

OUTPUT3 in rung 3 is energized, closing starting contactor 2S and starting the motor.

When the transition timer TR4 times out (in 30 seconds if the motor current has not dropped to or below the full-load setting or sooner if the current has dropped enough), the 1S contactor is immediately opened by the de-energizing of coil driver OUTPUT1 through the opening of NCTO contact TR4 in rung 4. About 30ms later run contactor R is closed upon the energizing of coil driver OUTPUT2 through NOTC contact TR4 and NC contact OUTPUT1 in rung 5. Seal-in contact OUTPUT3 in rung 3 keeps coil driver OUTPUT3 energized during the transition so that the transition is closed.

Once coil driver OUTPUT2 is energized, the incomplete sequence timer TR3 is started for 1s as shown in rung 7. One second later, when TR3 times out, contactor 2S is dropped when NCTO contact TR3 in rung 3 opens. If, when NOTC contact TR3 in rung 11 closes, the remote NC contact of run contactor R connected to remote input INPUT4 has not opened, the incomplete sequence LED is illuminated and the SAMMS goes into a fault condition and must be reset for normal operation to resume.

RUN light bar L2 in rung 9 is illuminated as long as either coil driver OUTPUT2 or OUTPUT3 is energized. The STOP light bar L1 and the flashing of the RUN light bar FL2 during the on delay are depicted in rungs 10 and 8, which are identical to rungs 7 and 8 in Figures 8 and 9.

When the STOP command is given, timing relay TR1 is de-energized, opening NOTC contact TR1 and de-energizing all of the coil drivers.

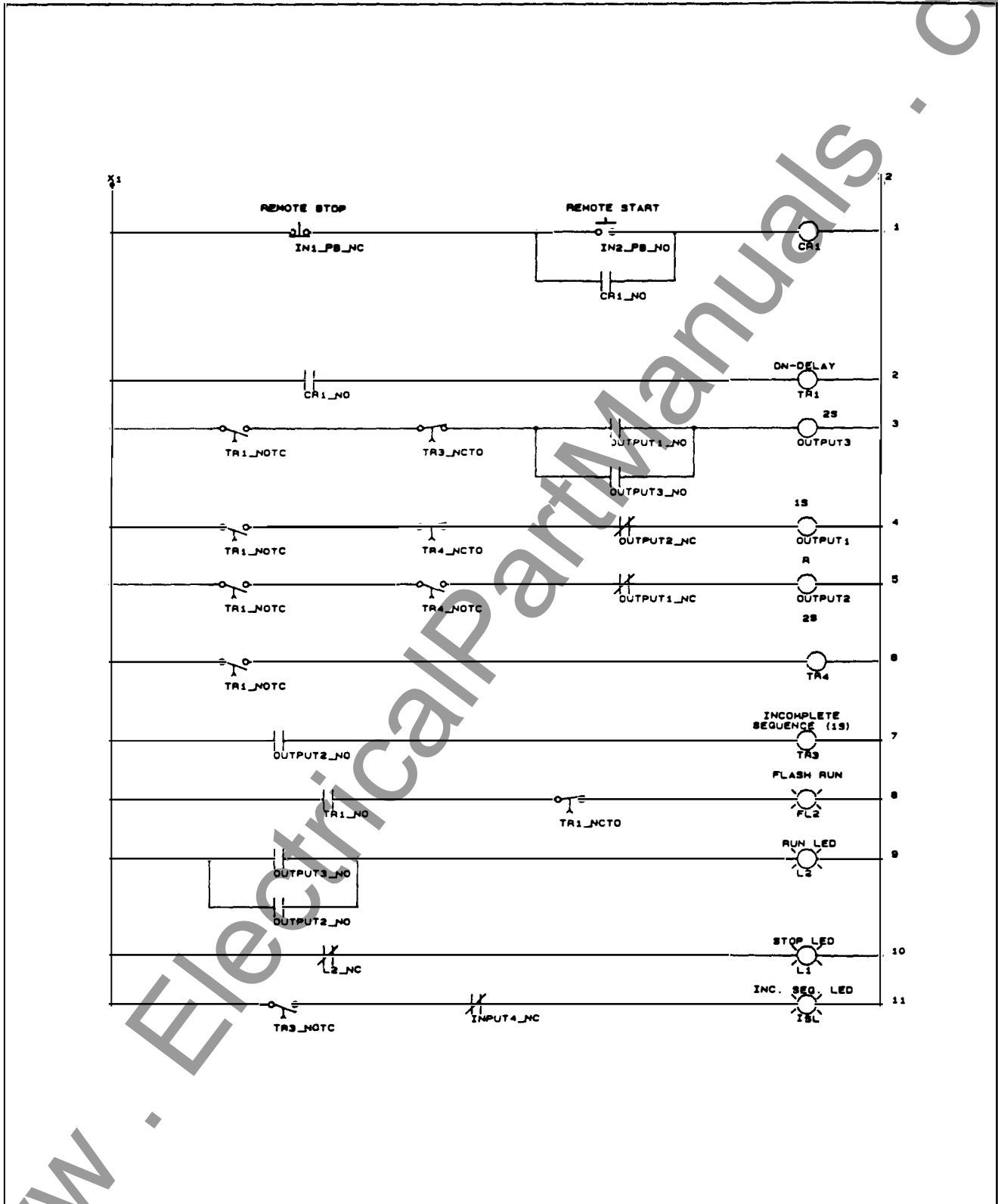

Figure 10. Ladder Diagram: reduced-voltage, autotransformer (NEMA sizes 5 and 6), remote three-wire

**6.9 Example 9**

**Starter type:**  
reduced-voltage, autotransformer  
(NEMA sizes 2-4)

**Control type:**  
remote three-wire

**Front-panel pushbuttons:**  
none

**Front-panel light bars:**  
L1 (STOP)  
L2 (RUN)

**Remote inputs:**  
INPUT1 (STOP)  
INPUT2 (START)  
INPUT4 (R NC)

**Output:**  
OUTPUT1 (S - starting contactor)  
OUTPUT2 (R - run contactor)  
OUTPUT3 (M - main motor contactor)

**Timers:**  
TR1 (on-delay)  
TR3 (incomplete sequence timer - 1s)  
TR4 (start-to-run transition - 30s)

**Flashing light bars:**  
FL2 (during on delay)

The ladder diagram of Figure 11 is identical to that of Figure 10, except for rungs 3 and 9. The NOTC contact of incomplete sequence timer TR3 is absent from the third rung of Figure 11, so that the M contactor driven by coil driver OUTPUT3 does not open one second after the transition to full-voltage. In rung 9, the NO OUTPUT2 contact of Figure 10 is absent from Figure 11. Because the M contactor driven by OUTPUT3 is closed as long as the motor is energized, the NO OUTPUT2 contact is sufficient for proper activation of the RUN light bar.

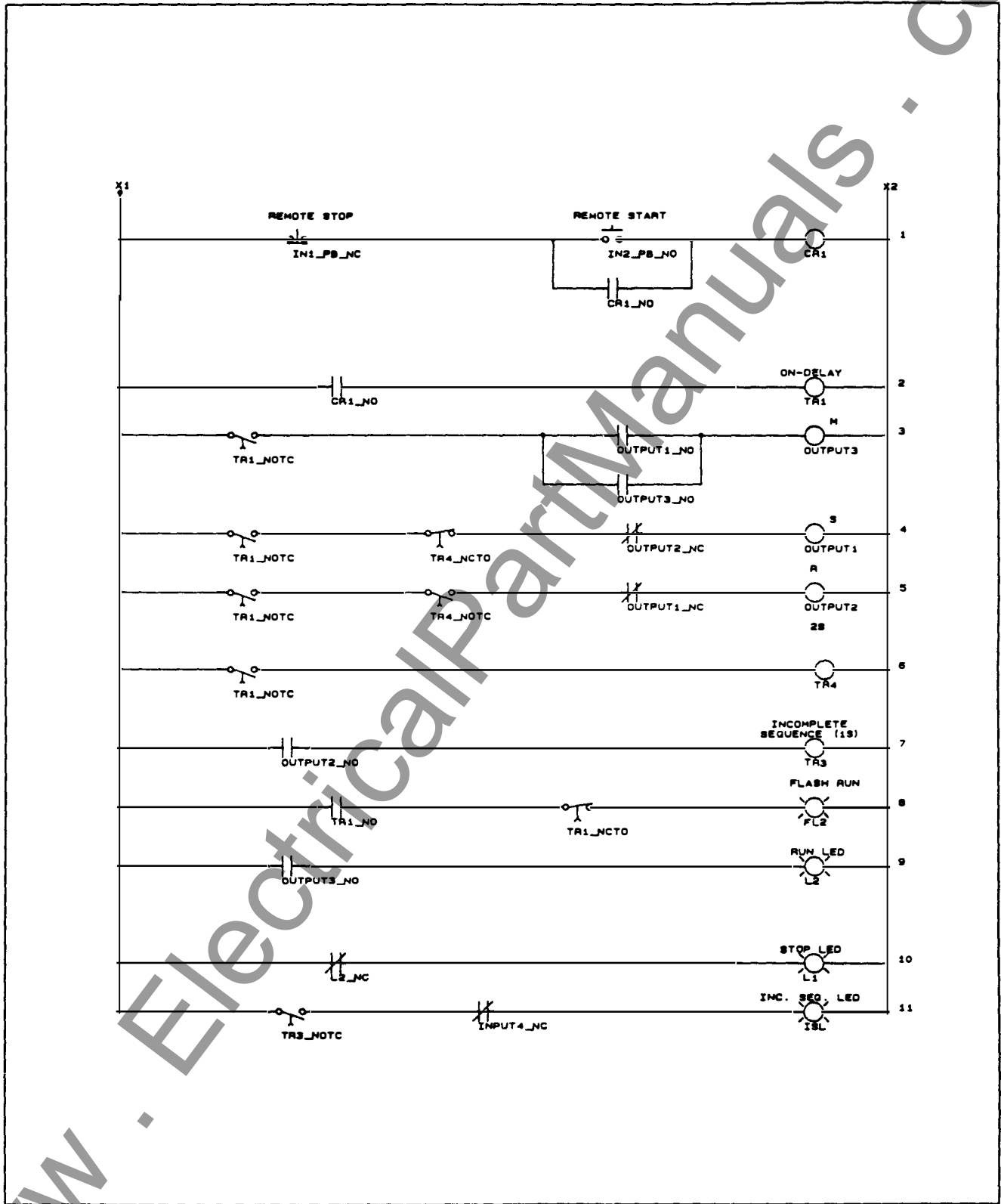

Figure 11. Ladder Diagram: reduced-voltage, autotransformer (NEMA sizes 2-4), remote three-wire

**6.10 Example 10**

**Starter type:**  
 wye-delta, closed-transition  
**Control type:**  
 remote three-wire  
**Front-panel pushbuttons:**  
 none  
**Front-panel light bars:**  
 L1 (STOP)  
 L2 (RUN)  
**Remote inputs:**  
 INPUT1 (STOP)  
 INPUT2 (START)  
 INPUT4 (2M NC)  
**Output:**  
 OUTPUT1 (1S - start contactor)  
 OUTPUT2 (2M via 1S(NC) - run contactor  
 2S via 2M(NC) - transition contactor)  
 OUTPUT3 (1M - start and run contactor)  
**Timers:**  
 TR1 (on-delay)  
 TR3 (incomplete sequence timer - 1s)  
 TR4 (start-to-run transition - 30s)  
**Flashing light bars:**  
 FL2 (during on delay)

Rungs 1 and 2 in Figure 12 are identical to the corresponding rungs in Figures 9-11. Motor sequencing is controlled by rungs 3-5 and 9 and the external connection of contactor coils and auxiliary contacts. Additional external wiring is required because the wye-delta, closed-transition circuits have four contactors and the SAMMS has only three coil drivers. Consequently, coil driver OUTPUT2 drives both the 2M run contactor and the 2S transition contactor, which are simultaneously energized for only a few cycles.

As soon as on-delay timer TR1 times out, NOTC contact TR1 in rungs 3-5 and 9 closes starting transition timer TR4 and energizing coil driver OUTPUT1 through NC contact OUTPUT2. Coil driver OUTPUT1 closes starting contactor 1S. About 30ms later NO contact OUTPUT1 in rung 5 closes energizing coil driver OUTPUT3 and closing start/run contactor 1M to start the motor under wye connection.

Upon the timeout of transition timer TR4, whether normally or early through intelligent reduced-voltage starting conditions, coil driver OUTPUT2 in rung 3 is energized by the closing of NOTC contact TR4. Coil driver OUTPUT2 closes transition contactor 2S through an external NC auxiliary contact of the 2M run contactor. About 30ms after the OUTPUT2 coil driver is energized, NC contact OUTPUT2 in rung 9 opens, de-energizing OUTPUT1 and dropping start contactor 1S. The 1M contactor, sealed in by contact OUTPUT3 in rung 5, remains closed. Once the 1S contactor drops out, its external NC auxiliary contact in series with the coil of run contactor 2M closes, causing run contactor 2M to pick up. The external NC contact of contactor 2M opens and drops out transition contactor 2S, completing the transition of the motor to running under delta connection.

Rungs 6-8 and 10-11 of Figure 12 for wye-delta, closed-transition are identical to rungs 7-11 for reduced-voltage, autotransformer in Figure 10, except for rung 6. In Figure 12, the NO OUTPUT3 contact is adequate to control the illumination of RUN light bar L2.

When the STOP command is given, timing relay TR1 is de-energized, opening NOTC contact TR1 and de-energizing all of the coil drivers.

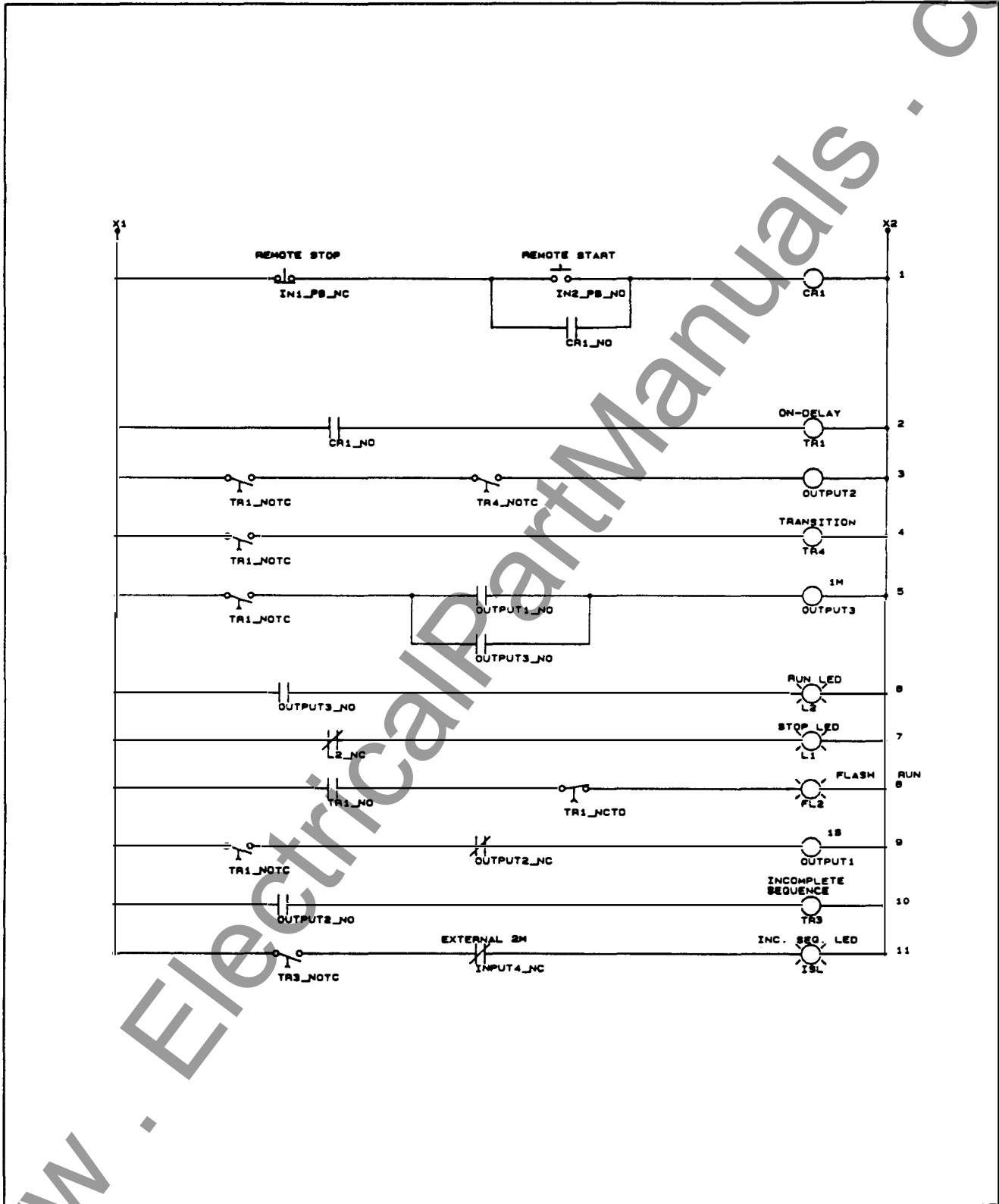

Figure 12. Ladder Diagram: Wye-delta, closed transition, remote three-wire

**6.11 Example 11****Starter type:**

two-speed, one-winding, constant horsepower

**Control type:**

local two-wire

**Front-panel pushbuttons:**

SW1 (OFF)  
SW2 (LOW)  
SW3 (HIGH)

**Front-panel light bars:**

L1 (STOP)  
L2 (LOW)  
L3 (HIGH)

**Remote inputs:**

none

**Output:**

OUTPUT1 (motor low)  
OUTPUT2 (motor high)  
OUTPUT3 (wye configuration for low)

**Timers:**

TR1 (on-delay)  
TR2 (low lockout delay after stop from high)

**Flashing light bars:**

FL2 (during on delay low)  
FL3 (during on delay high)

**Serial communications inputs:**

C\_PB1 (OFF)  
C\_PB2 (LOW)  
C\_PB3 (HIGH)

The two-speed, one-winding, constant horsepower two-wire control of Example 4 (Figure 6) can be modified for acceptance of OFF, LOW, and HIGH commands over the serial communications interface. The modified ladder is shown in Figure 13. The only differences between Figure 6 and Figure 13 are in the first two rungs. In both rungs, the NC communications OFF input C\_PB1 is in series with the rung, permitting the motor to be stopped over the serial communications interface. In rung 1, the NO LOW input C\_PB2 is in parallel with the front-panel LOW button SW2, so that either SW2 or C\_PB2 can start the motor in LOW. The NO HIGH input C\_PB3 in rung 2 operates similarly for high-speed operation. Like the front-panel pushbuttons, the communications inputs are inherently momentary devices. Any latching of serial communications commands must be handled by the ladder diagram.

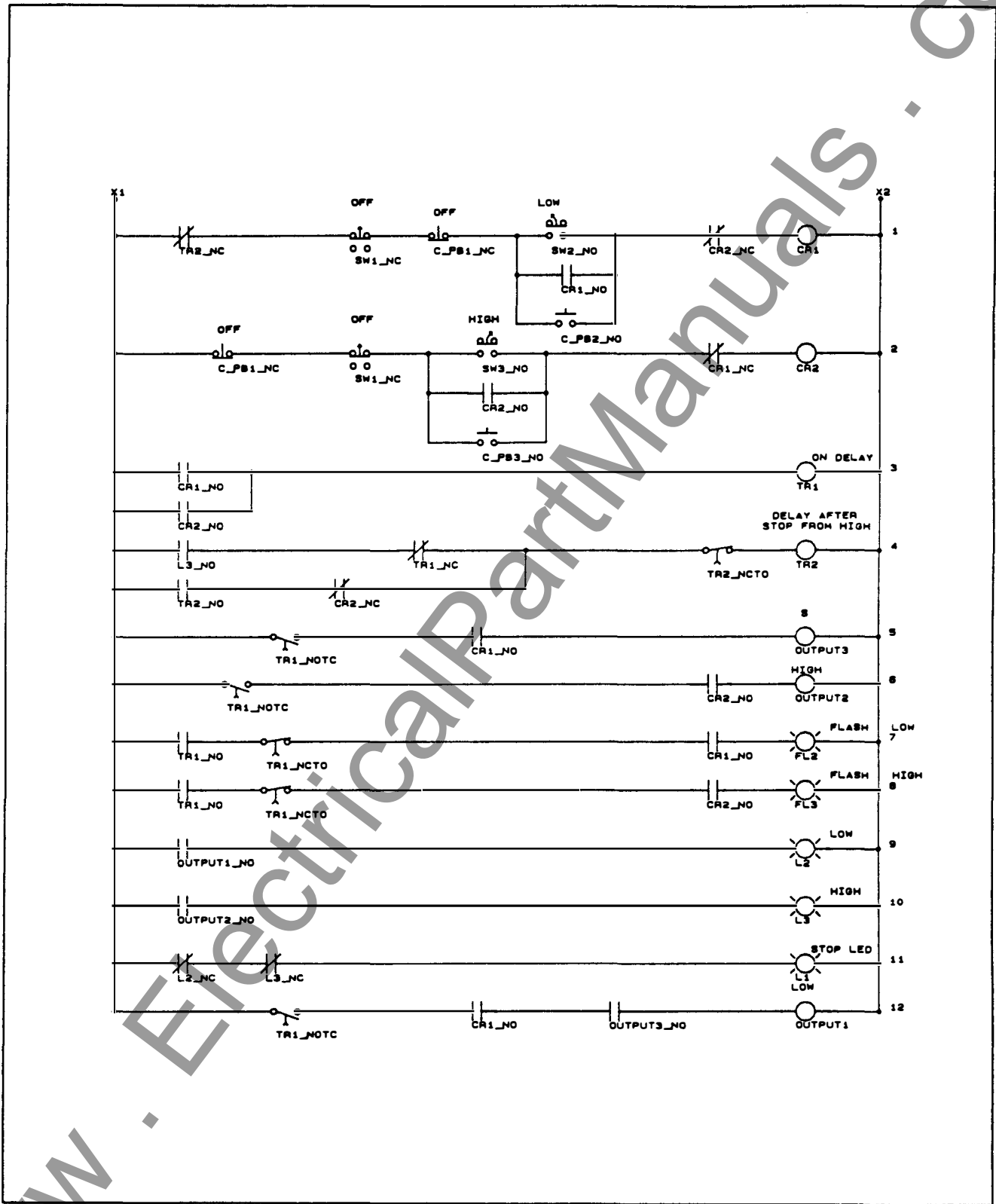

Figure 13. Ladder Diagram: two-speed, one-winding, constant horsepower, local two-wire with communications Inputs

**6.12 Example 12****Starter type:**

two-speed, one-winding, constant horsepower  
(direct transition from low- to high-speed)

**Control type:**

local two-wire

**Front-panel pushbuttons:**

SW1 (OFF)  
SW2 (LOW)  
SW3 (HIGH)

**Front-panel light bars:**

L1 (STOP)  
L2 (LOW)  
L3 (HIGH)

**Remote inputs:**

none

**Output:**

OUTPUT1 (motor low)  
OUTPUT2 (motor high)  
OUTPUT3 (wye configuration for low)

**Timers:**

TR1 (on-delay)  
TR2 (low lockout delay after stop from high)

**Flashing light bars:**

FL2 (during on delay low)  
FL3 (during on delay high)

**Serial communications inputs:**

C\_PB1 (OFF)  
C\_PB2 (LOW)  
C\_PB3 (HIGH)

The two-speed, one-winding, constant horsepower two-wire control of Example 11 (Figure 13) can be modified as shown in Figure 14 to permit the direct transition from low- to high-speed operation without the need to first stop the motor. The only differences between Figures 13 and 14 are in rungs 1 and 3. In rung 1, the NC front-panel HIGH input SW3 and the communications HIGH input C\_PB3 are connected in series to disable CR1, which latches in low-speed inputs, as soon as the HIGH input is given. To prevent the on-delay timer from releasing and re-setting during the low- to high-speed transition, NO timer seal-in contact TR1 and NC STOP light contact L1 are added to rung 3. When the low- to high-speed transition is made, both NO contacts CR1 and CR2 are open for a brief interval. NC contact L1 and NO seal-in TR1 remain closed during the brief interval, preventing the interruption of timer TR1. Only when the motor is finally stopped does the NC contact L1 open, completely de-energizing TR1.

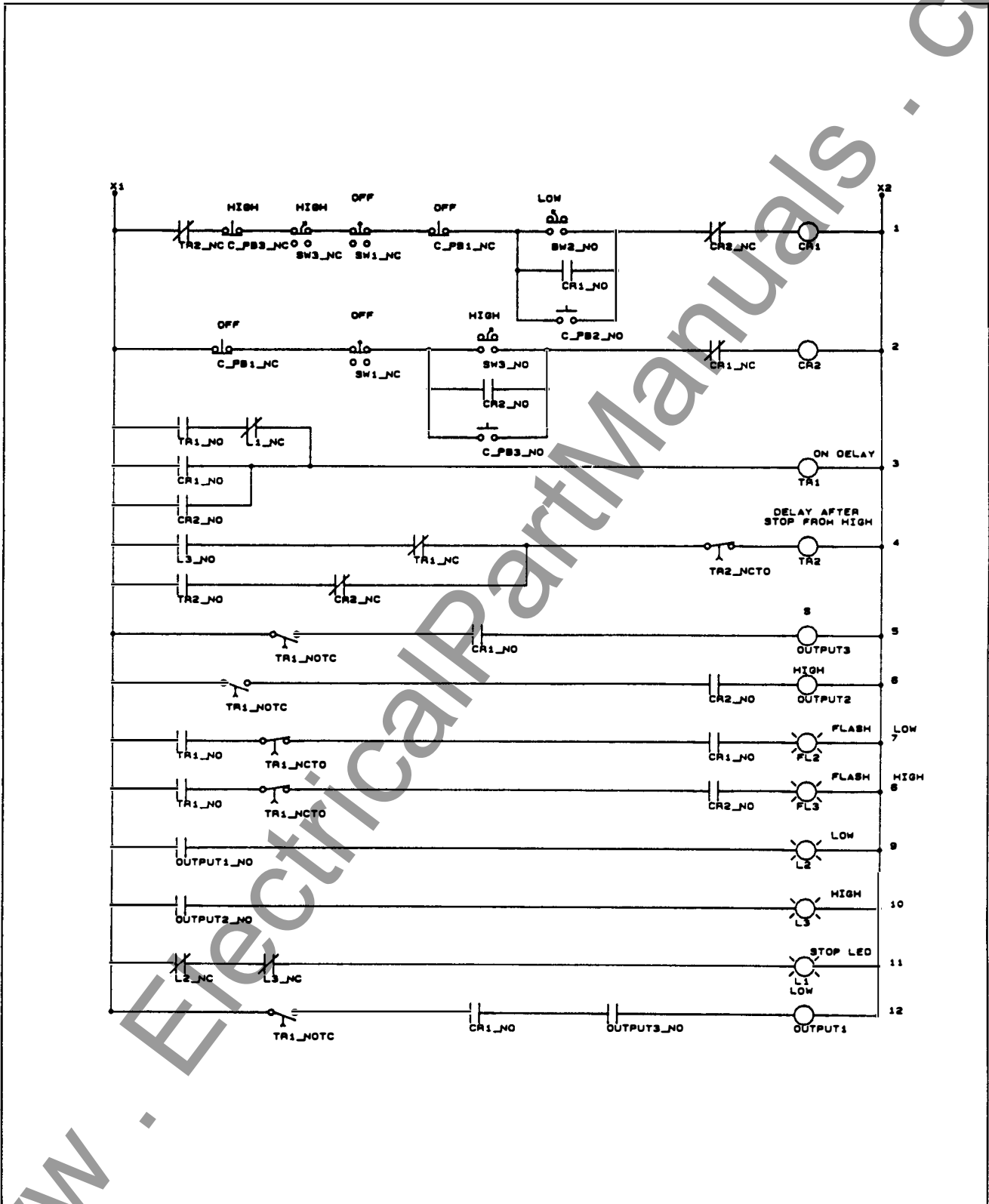

Figure 14. Ladder Diagram: two-speed, one-winding, constant horsepower (direct transition from low to high speed), local two-wire with communications inputs

# Contents

## Section 2

<b>Introduction .....</b>	<b>2-1</b>
<b>Features of SAMMS Custom Software .....</b>	<b>2-1</b>
Software Versions .....	2-1
SAMMS/OrCAD Parts Library .....	2-2
Utility Programs .....	2-2
Trouble Shooting .....	2-3
How to Use the Information in this Section .....	2-3
<b>Setting Up.....</b>	<b>2-4</b>
What You Need to Begin .....	2-4
Installing SAMMS Software .....	2-4
Making Backup Copies .....	2-4
Installation on a Hard Disk System .....	2-4
Configuring OrCAD .....	2-5
<b>Using Your Software .....</b>	<b>2-6</b>
Command and Menu Organization .....	2-6
Using the Menu Screen .....	2-6
Commands .....	2-7
<b>Tutorial .....</b>	<b>2-10</b>

## Section 2: SAMMS Custom Software

### 1. Introduction

The Siemens Advanced Motor Master System (SAMMS) Custom Software Package is a complete and easy to use program for creating ladder circuits for motor control applications and converting them to microprocessor machine code for the SAMMS. Easy to use menu driven commands enable you to create your own custom ladder circuits, use or modify the supplied standard ladder motor control circuits and customize your SAMMS.

The program was designed to run on IBM personal computers and compatibles and requires only the addition of a supplied power source and Download Interface Module between the SAMMS and your computer to allow full use of this package.

#### 1.1 Features of SAMMS Custom Software

The complete SAMMS software package consists of all the necessary tools for drafting custom motor control ladder circuits, configuring your SAMMS and downloading files from your computer to your SAMMS.

##### 1.1.1 Software Versions

SAMMS software packages can be obtained for any of three different user levels, depending on the degree of user flexibility required. Below is a description of the different packages which are available.

#### **SAMMS Premium Software Package**

This package offers its users maximum flexibility and features.

It is recommended for users maintaining large numbers of complex motor control circuits. It also offers maximum flexibility in maintaining or re-configuring the SAMMS. It gives the customer total control over his motor control circuits, which leads to fast turnaround times and the ability to program custom circuits without having to wait for factory lead times. You get exactly what you want, when you want it!

Specifically, this premium software package affords its users the following capabilities:

1. Generate custom motor control ladder circuits.
2. Compile custom, standard or modified ladder circuits.
3. Configure SAMMS motor parameters for each ladder circuit.
4. Communicate with SAMMS to download ladder circuits and motor parameters.

The software components of this version consist of the following:

- ORCAD® software for generating custom ladder circuits
- Library of over 70 standard motor control ladder circuits
- Library of standard components for building custom ladder circuits
- Compiler software for converting custom ladder circuits to microprocessor machine code
- Configuration software to customize SAMMS motor parameters
- Communication software to download ladder circuits and configuration information to SAMMS
- Menu selection software for quick and easy use

#### **SAMMS Standard Software Package**

This software package offers users all the benefits of the above premium package except the ability to create custom motor control ladder circuits or modify the supplied standard ladder circuits. This package is recommended for users that do not need this added flexibility and have control circuits consisting primarily of the supplied standard control ladder circuits. It still offers users the ability to quickly configure the SAMMS with a new standard ladder

circuit or change certain motor parameters that are not reconfigurable once the SAMMS has been programmed at the factory and installed.

Specifically, this standard software package allows users the following capabilities:

1. Configure SAMMS motor parameters for each standard ladder circuit.
2. Communicate with SAMMS to download ladder circuits and motor parameters.

The software components of this version consist of the following:

- Over 70 compiled standard motor control ladder circuits
- Configuration software to customize SAMMS motor parameters
- Communication software to download ladder circuits and configuration information to SAMMS

### **SAMMS Backup Software Package**

The SAMMS backup package gives users the ability to configure SAMMS which are kept as spare parts. This gives the customer the advantage of stocking only a few SAMMS as backup units for his motor controllers. In the event that a SAMMS needs to be replaced quickly, the user can easily download the supplied backup files to the spare SAMMS. These backup files meet the exact motor parameters and ladder circuits as originally specified from the factory. This package is recommended for the user that does not need the flexibility to change ladder circuits and only wants to maintain his present motor controllers. This package still gives users the benefit of having control over their maintenance and repair procedures.

Specifically, this software package gives users the following capability:

Communicate with SAMMS to download backup versions of ladder circuits and initial motor parameters as supplied by the factory.

The software components of this version consist of the following:

- Compiled ladder circuits and motor parameters as initially specified from the factory for each motor controller
- Communication software to download ladder circuit and configuration information to the SAMMS

### **1.1.2 SAMMS/OrCAD Parts Library**

Included with the OrCAD drafting software is a custom parts library which allows users to easily generate ladder circuits. These library symbols are similar to the symbols used with today's electro-mechanical components. A detailed description of the ladder circuit components can be found in Figure 1 of Section 1 of this manual.

### **1.1.3 Utility Programs**

Easy to use utility programs configured with your menu selection program allows you versatile functions, including:

#### **Draft OrCAD Ladders:**

This program allows you to generate custom ladder diagrams or view and modify existing ladder circuits to be used with the SAMMS.

#### **Compile Ladder Circuits:**

With this utility program, you can easily compile any new or modified ladder circuit before downloading to your SAMMS.

#### **Make a Download File:**

This utility allows you to program the initial motor parameters for your SAMMS and link them with a compiled ladder circuit.

#### **Download to SAMMS:**

With this program you are able to download your custom download files or backup files to the SAMMS.

#### **File Utilities:**

These basic DOS utilities enable you to easily access your ladder circuits, compiled ladders or download files.

### 1.3 Trouble Shooting

The main problem with software not running properly is improper configuration. Make sure your installation is correct if you are having problems executing programs.

Refer to your OrCAD manual for problems running your OrCAD drafting program.

For a computer or a mouse problem, consult your user's manual.

### 1.4 How to Use the Information in this Section

This section is written to describe all the options available with the SAMMS PREMIUM SOFTWARE PACKAGE. All three versions of the software, however, can easily use this section since they are merely subsets of each other, and options which you do not have can be ignored.

## 2. Setting Up

After reading the introduction of your SAMMS Custom Circuits Manual, you will need to install OrCAD and the utility programs on your personal computer.

This section will describe how to install your version of software on a hard disk system. You will need to refer to your OrCAD manual to install your particular graphics, printer and plotter selections for use with OrCAD. The end of this section will show you a sample configuration.

### 2.2 What You Need to Begin

You will need the following items supplied with your particular SAMMS software package.

#### Premium Package

Install Disk I	SAMMS Disk ID
SAMMS Disk IA	SAMMS Disk IE
SAMMS Disk IB	OrCAD Disks
SAMMS Disk IC	

#### Standard Package

Install Disk II	SAMMS Disk IIC
SAMMS Disk IIA	SAMMS Disk IID
SAMMS Disk IIB	SAMMS Disk IIE

#### Backup Package

Install Disk III
Backup Job Disks

You will need to supply the following:

1. IBM PC/XT/AT/286/386, PS/2 or 100% compatible computer with a hard disk system and one floppy drive.
2. A n EGA or higher graphics card and monitor for the SAMMS Premium Software Package.
3. MS-DOS® Version 2.1 or greater.
4. 640K bytes of memory.
5. Disks for making backup copies.

### 2.3 Installing SAMMS Software

Before installing SAMMS software, you should be familiar with your directory structure. The SAMMS software will be installed in the present working directory, so you should change to the sub-directory that you want before running the installation program.

#### 2.3.1 Installation on a Hard Disk System

Your SAMMS software should be installed on a hard disk system. The automatic installation disk causes your software to be loaded in an organized sub-directory structure. All the files will be installed under the sub-directory called SAMMS. If you want this sub-directory to appear under one of your other sub-directories, run the install program from that directory as opposed to the root directory.

Insert the floppy disk labeled INSTALL DISK into your floppy disk drive.

Be sure you are in the root directory or sub-directory on your hard disk that you want your SAMMS software loaded to. At the hard disk DOS prompt enter:

```
<f>:install <f> <d>
```

where <f> = the floppy disk drive containing the install disk

and <d> = the hard disk drive to be loaded

As an example, to install the SAMMS software on your hard disk drive "C", with the install disk inserted in the floppy drive "A", the command line given at the hard disk DOS prompt would be:

```
a:install a c
```

The installation program will prompt you for inserting the proper floppy disk at the proper time. It will also automatically create all the necessary directories and copy all the files from the floppies to your hard disk.

Please complete and mail in the registration card. This guarantees you technical support and upgrade information.

This completes the installation of SAMMS software on a hard disk system.



It is important that the DRIVER PREFIX LIBRARY PREFIX and WORKSHEET PREFIX are configured as shown for OrCAD to run properly with the SAMMS software directories.

The SAMMS ladder circuit parts library and ladder circuits are automatically installed as part of OrCAD.

## 2.4 Configuring Orcad

Section 2.4 of your OrCAD manual provides information on configuring OrCAD for your particular system. Figure 2-1 shows an example configuration for accessing all the available options when used in conjunction with your SAMMS software package. Typing DRAFT/C from the SAMMS\OrCAD directory enables the OrCAD configuration screen.

```

::: CONFIGURATION OF OrCAD/SDT :::
DP - Driver Prefix      DRIVER\
DD - Display Driver    VGA640.DRV
PD - Printer Driver    HPLASER2.DRV
PL - Plotter Driver    HP.DRV
LP - Library Prefix    LIBRARY\
LF - Library Files     SIEM1.LIB

WP - Worksheet Prefix  SHEET\
MF - Macro File
IM - Initial Macro     ^I
MB - Macro Buffer Size  8192
HB - Hierarchy Buffer Size 1024
CT - Color Table / Plotter Pen Table
TT - Template Table
U - Update Configuration Information
Q - Quit, Abandon to DOS
R - Run Program
Command?
KF - Key Field Configuration

```

Figure 2-1. OrCAD Configuration Menu

### 3. Using Your Software

Section 1 outlined the basic features of your SAMMS and OrCAD software packages. This section will detail the use of the menu screens and commands.

#### 3.1 Command and Menu Organization

Your SAMMS and OrCAD software commands are invoked by an easy to use menu screen. This menu system is intended for a single, stand-alone PC and allows you access to SAMMS programs through easy-to-understand menu options. This also allows you to no longer worry about understanding the intricacies of MS-DOS. The menu features an intuitive screen display and optional mouse support.

This menu and the SAMMS software is arranged in a hierarchical fashion as a way to organize the many ladder circuits and download files and to keep pro-

gram and data files in separate directories. This structure is automatically generated and maintained, and it is important to keep this structure for the software to run properly. It also allows an easy way to track and organize your motor control circuits in your plant.

##### 3.1.1 Using the Menu Screen

To execute any SAMMS software version, enter the SAMMS directory and type:

**SAMMS**

This command will display the menu shown in Figure 3-1. The premium SAMMS software will show nine executable selections, A through I. The standard SAMMS software package will show only seven selections, and the backup SAMMS software package will display only two selections.

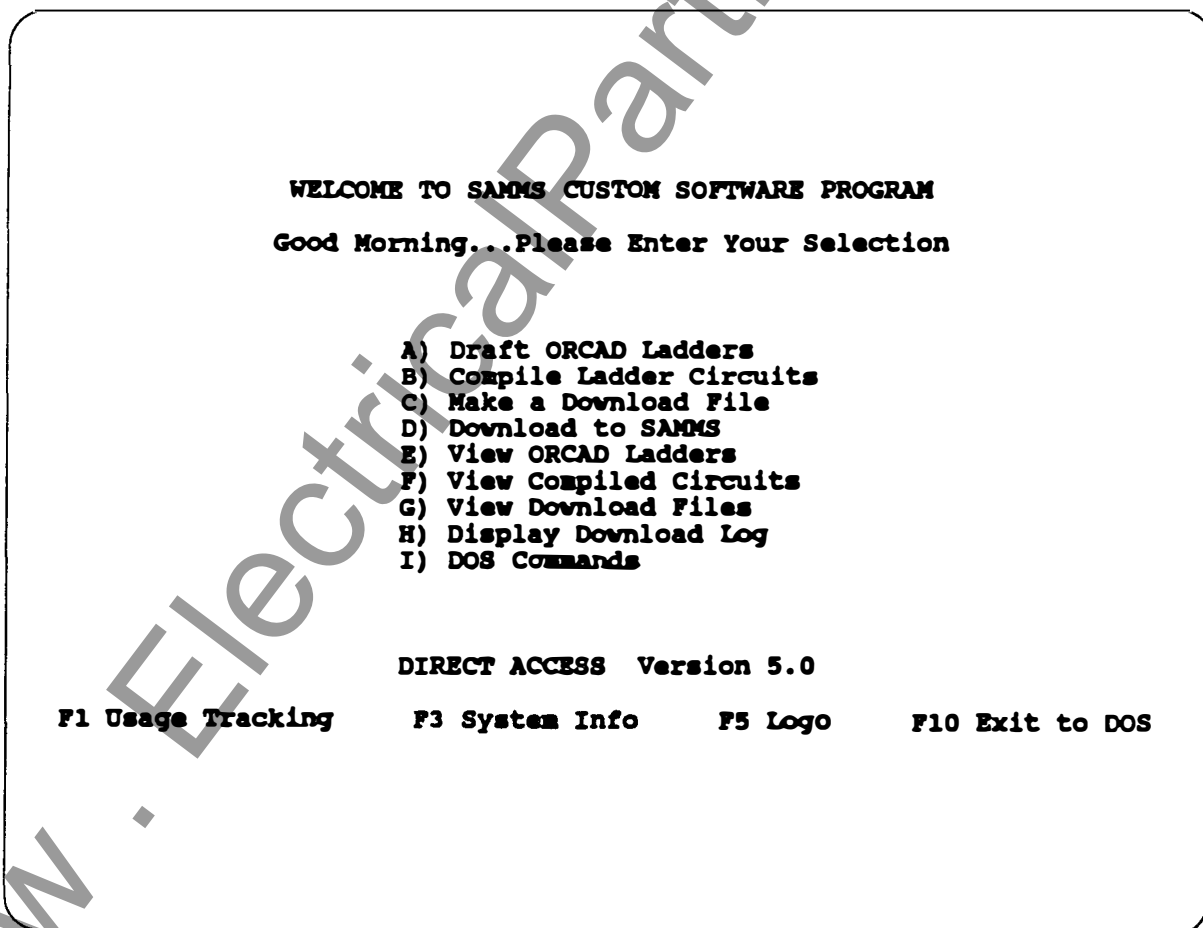

Figure 3-1. Main Menu Screen

Your menu system has optional mouse control. To make your mouse operate properly, both the mouse hardware and mouse software must be properly installed before entering the menu screen.

There are two methods you can use to select a menu item:

- Press the menu selection's label (for example, A, B, etc).
- Move the mouse cursor to the menu choice, and press the mouse's left button twice quickly in sequence (double click).

You must follow some basic DOS rules in naming ladder circuit filenames. The following rules apply to naming both files and directories:

- Can contain all letters, numbers, and the following special characters \$ # & @ ! % ( ) - { } ' \_
- Maximum length of eight characters

### 3.1.2 Commands

This section describes the SAMMS commands in the order they appear on the menu screen.

#### Draft OrCAD Ladders

This command is used for designing, modifying or viewing ladder circuits for the SAMMS.

1. Select the draft command from the main menu screen.
2. Enter the name of the new ladder circuit to be drawn or an existing ladder circuit (with no extension) at the next menu prompt.



In order for SAMMS software to function properly, ladder circuits always have .SCH extensions. The menu program automatically appends a .SCH extension to the ladder circuit filename. If you are generating multiple ladder circuits from ORCAD, it is important that you always define an .SCH extension for your ladder circuit.

Example: LADDER1 (as defined in the menu screen)  
LADDER1.SCH (as defined in ORCAD)

3. You should now be in the OrCAD drafting program. Pressing the ENTER key twice, when prompted, will put you in the main OrCAD screen and enable you to begin designing ladder circuits.

Ladder circuits always reside in the SAMMS\ORCAD\SHEET directory so they can be accessed by the other SAMMS software functions.

4. Refer to your OrCAD user's manual, the standard circuits manual or the tutorial in Section 4 for specifics in designing ladder circuits.

#### Compile Ladder Circuits

This selection converts your newly created or modified standard ladder circuit into machine code for the microprocessor in the SAMMS. This must be performed before the ladder circuit can be downloaded to the SAMMS.

1. Select the compile command from the main menu screen.
2. Enter the name of the ladder circuit you want compiled at the next menu prompt (with no extension).

Example: PB10

3. The next menu prompt asks you to enter the job name you want to assign to the compiled ladder. This can be a reference to a particular motor starter or location or can have the same name as the ladder circuit.

The software automatically creates a directory to store the compiled ladder circuit. No extension is allowed.

Example: JOB\_#102

The program then asks "Which A.C. inputs are wired through normally closed contacts?". This refers to any remote 120 VAC inputs which are wired to the SAMMS. This custom function allows you to draw the physical normally closed remote contact as a normally closed symbol in your ladder circuit. This eliminates the need to invert the symbol to a normally opened contact as you would have to do with a programmable logic controller. The resulting ladder circuit is a true representation of your starter.

The program would compile ladder circuit PB10 and store it in the directory JOB\_#102. JOB\_#102 is now the compiled circuit name to be linked with the motor parameters for a particular SAMMS.

### Make a Download File

This command creates the complete download file for the SAMMS. It first asks for the compiled ladder circuit as above and then links it with the motor starter data entered in this step.

1. Select the configure command from the main menu screen.
2. The next prompt will ask you which compiled ladder circuit you want to link with. This might be JOB\_#102 as above.



The SAMMS Standard Software Package is supplied with pre-compiled ladder circuits named PB10 through PB80. The SAMMS Backup Software Package is supplied only with the jobs supplied by the factory as specified by the customer.

3. The next prompt asks what you would like to name your download file. It can be the same or different than the compiled ladder circuit job name. No extension is allowed.

Example: PUMP\_#47

4. The program will then prompt you with a series of questions to customize your SAMMS and enter the specific motor parameters.

The above examples would produce a download file named JOB\_#102\PUMP\_#47.SFT. Note that a .SFT extension is appended to designate it as a download file. Multiple .SFT download files can be stored in each job directory.



The SAMMS is available in three different models, Standard, Diagnostic and Premium. It is not possible to change the hardware version of the SAMMS as it was originally configured at the factory. When prompted to enter the version of the SAMMS you are programming, be sure the correct response is entered or the download procedure will generate an error message and not load the circuit. Refer to your SAMMS User's Manual for descriptions of the SAMMS hardware versions.

You can view the configuration for a particular SAMMS unit by selecting the Display Download Log command from the main menu screen.

See Figure 3-2 for a diagram showing the file organization.

### Download to SAMMS

This program establishes communications between your PC and the SAMMS, allows selection of your download file and downloads to the SAMMS.

1. Plug the SAMMS Download Interface Module to the communication port of the SAMMS and your PC as shown in Figure 3-3, with control power removed from the SAMMS.
2. Attach the SAMMS power source cable to terminals 5 and 6 of the SAMMS then plug the source into 120VAC, 60Hz power supply.



The Download Interface Module must be plugged into the SAMMS device when control power is off. The SAMMS senses the module and is configured for downloading only during the first second after control power is applied. Only the green READY indicator on front of the SAMMS should be on.

3. Select the download command from the main menu screen.
4. Enter your compiled ladder circuit name.

Example JOB\_#102

5. Enter your download file name.  
Example PUMP\_#47
6. Enter your serial communications port number.
7. After the file is downloaded, remove the interface module and power for at least five seconds. Reapply the power source only and verify your circuit.

**File Utilities**

The menu screen performs common MS-DOS tasks without the need to enter lengthy or repetitive commands. The file utilities allow you to view existing ladder circuits, download files and download logs.

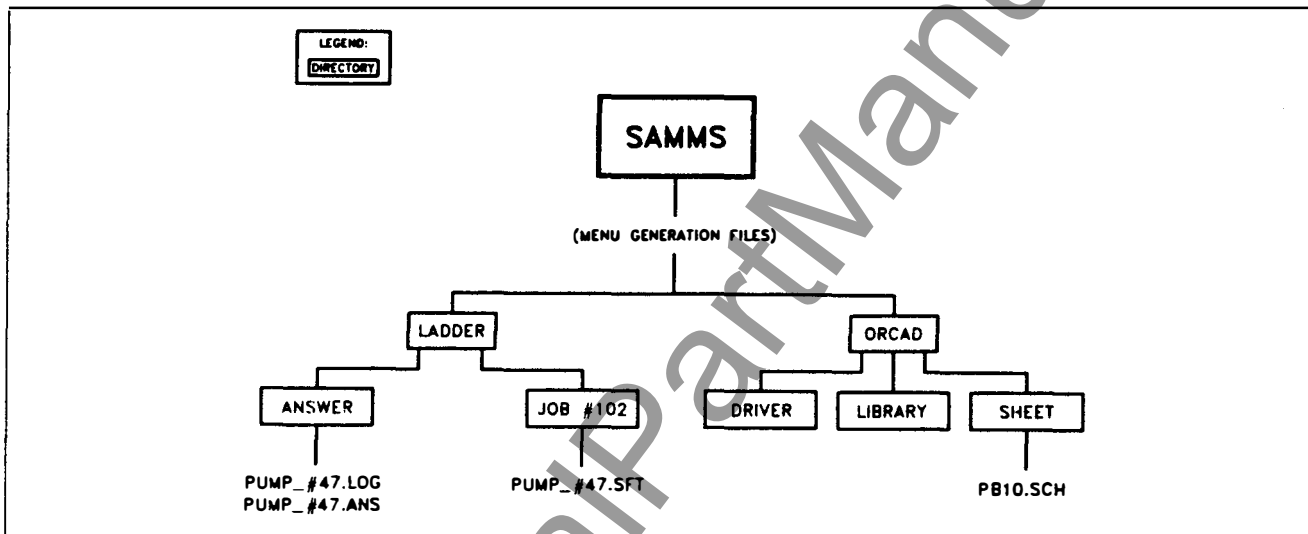

**Figure 3-2. SAMMS File Structure**

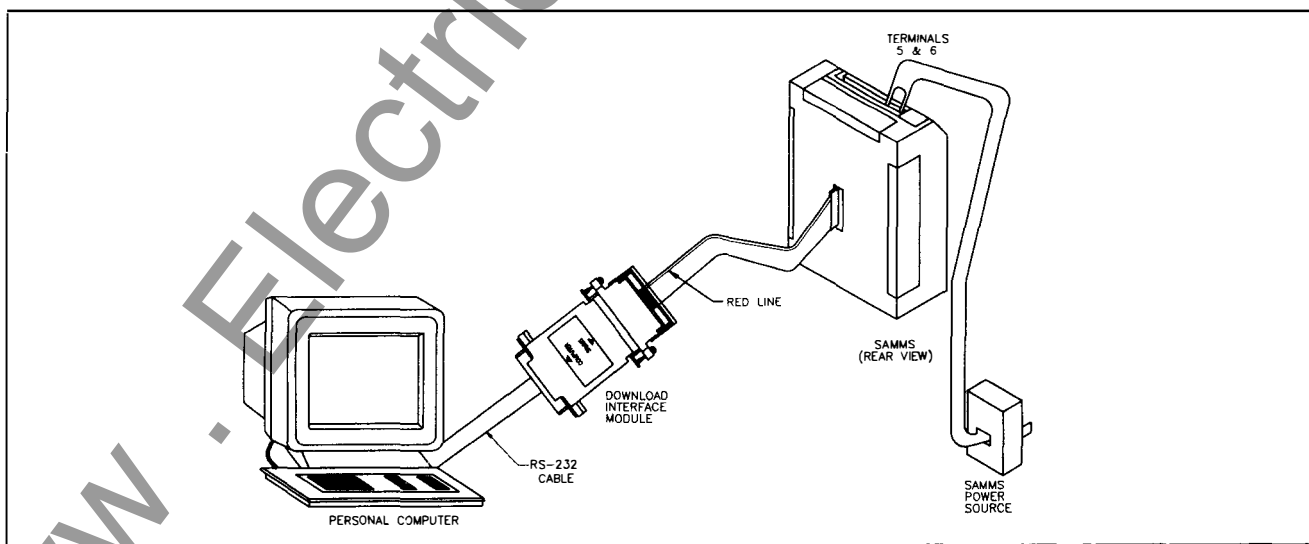

**Figure 3-3. SAMMS Communication Setup**

#### 4. Tutorial

The following example demonstrates SAMMS PREMIUM SOFTWARE PACKAGE commands, assuming mouse control. Refer to the following Figures 4-1 to 4-4.

Note: Right Mouse Button = Escape Key  
Left Mouse Button = Enter Key  
Mouse Control = Arrow Keys

##### To draw a ladder circuit:

1. Select "DRAFT LADDER CIRCUITS" from the main menu.

##### Main Menu Commands:

- A Draft OrCAD Ladders
- B Compile Ladder Circuits
- C Make a Download File
- D Download to SAMMS

2. Enter ladder circuit filename: TEST
3. Press ENTER key twice, when prompted. You should see Figure 4-1.

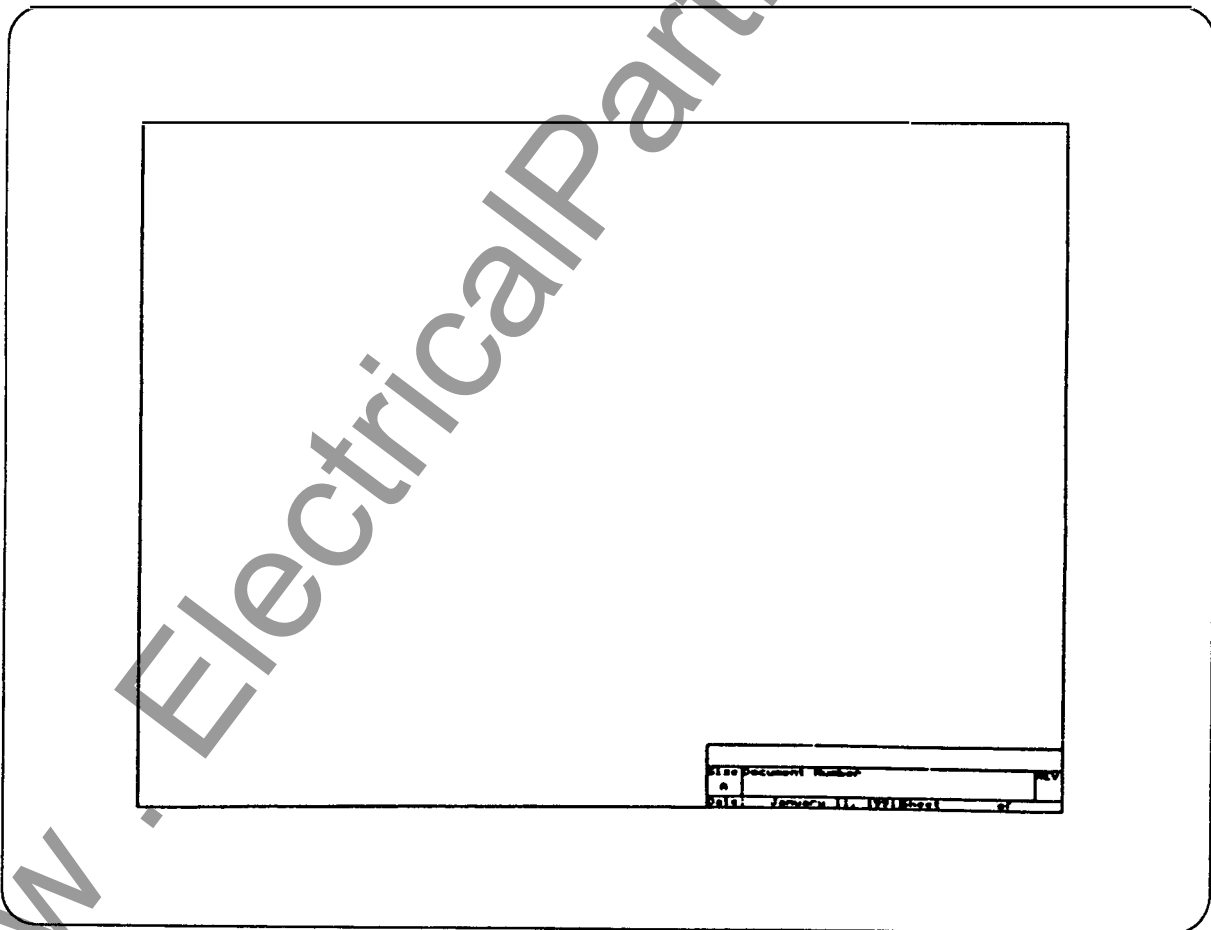

Figure 4-1.

4. Press left mouse button to display drop menu.

You should see Figure 4-2.

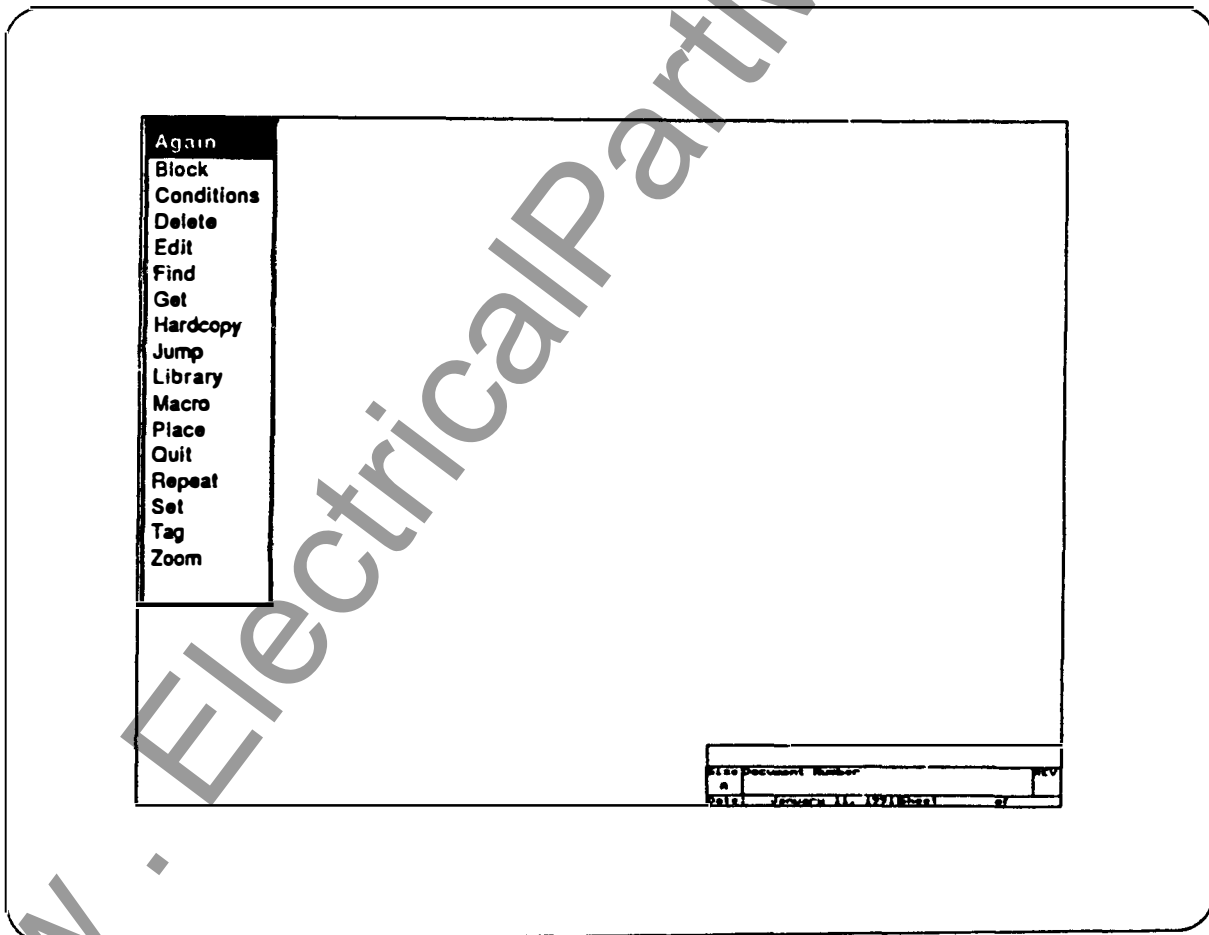

Figure 4-2.

16. Press left mouse button to display main menu again.
17. Select GET.
18. Retrieve CR1\_NO (Control Relay 1, Normally Open) as with X1 and X2.
19. Position as in Figure 4-5.

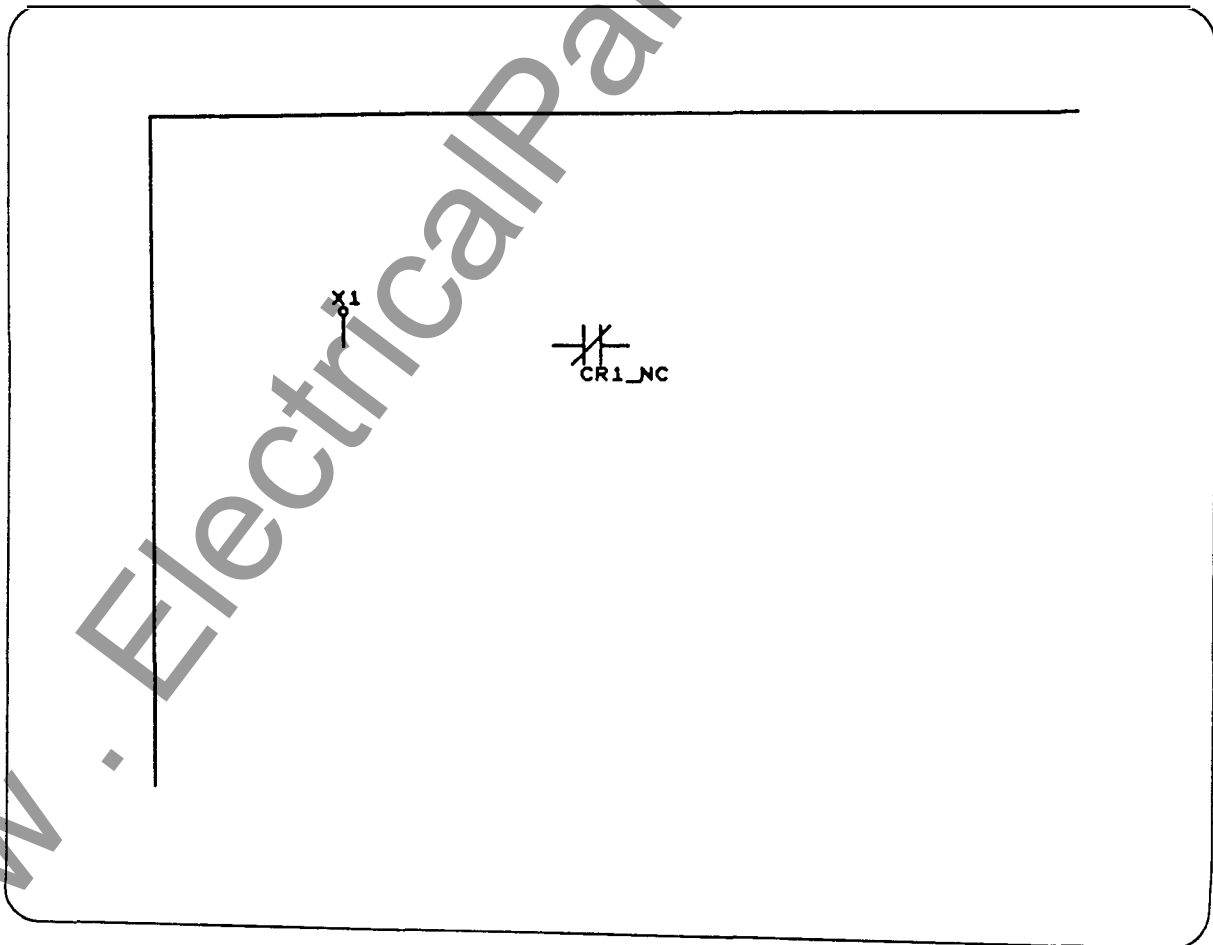

Figure 4-5.

20. Select PLACE from main menu.
21. Select WIRE from sub-menu.
22. Position mouse arrow as in Figure 4-6.

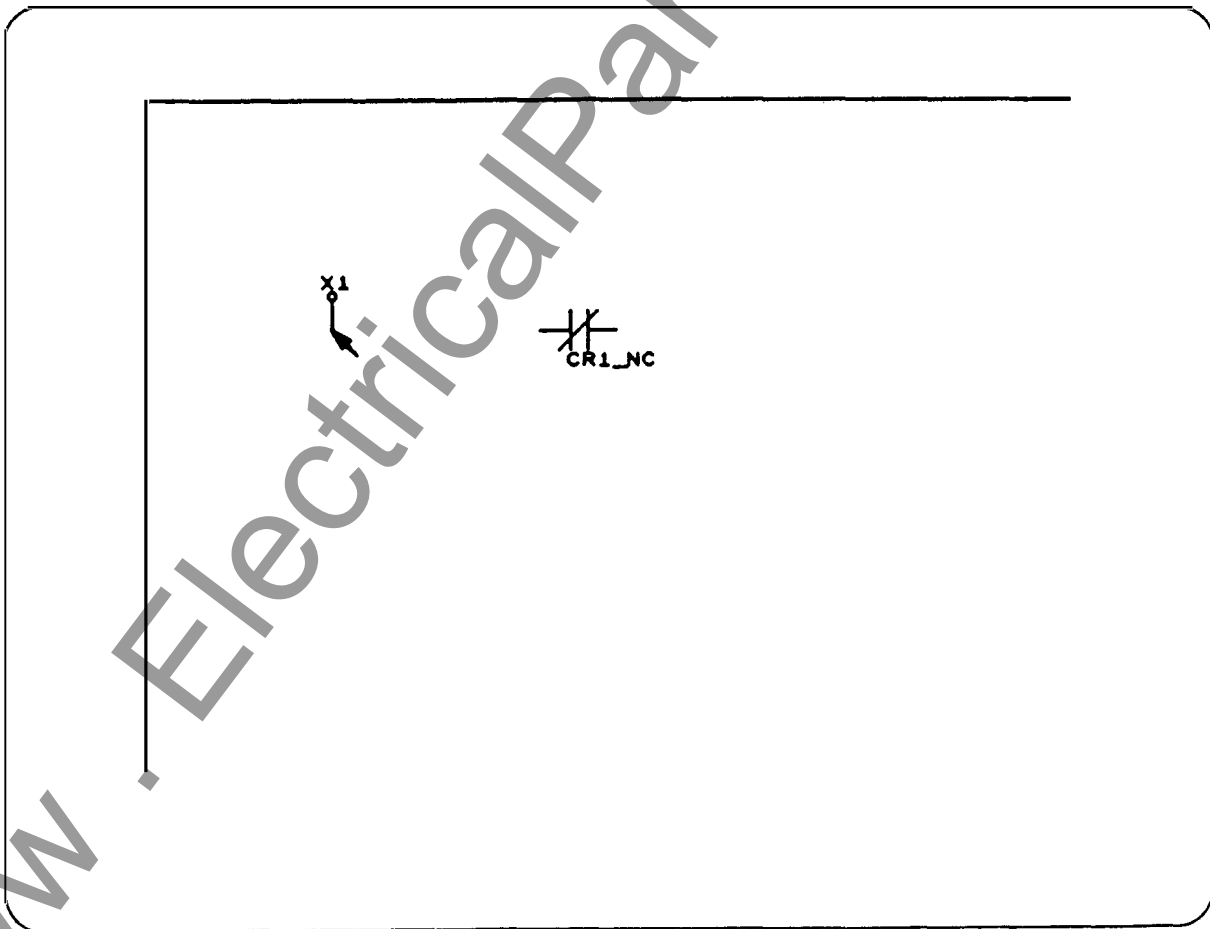

Figure 4-6.

23. Press left mouse button to select BEGIN.
24. Move mouse to connect X1 to CR1\_NO with wire.
25. Press left mouse button to select END.
26. Repeat process to draw ladder and ZOOM OUT to produce Figure 4-7.



Note: The connection MUST be made at the tip of the part lead, otherwise errors will occur when compiling the circuit.

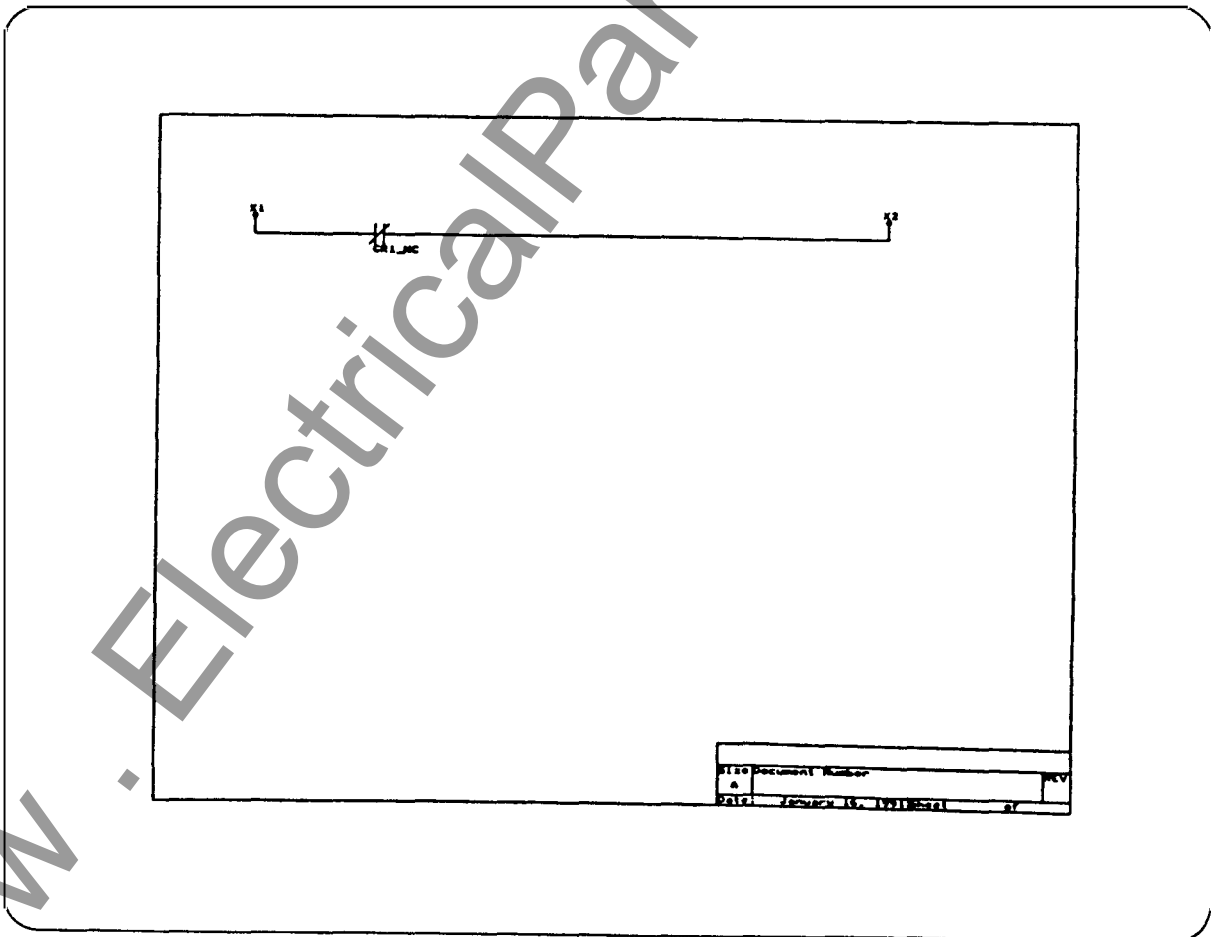

Figure 4-7.



**To compile a ladder circuit:**

1. Select "COMPILE LADDER CIRCUITS" from the main menu.
2. Enter the ladder circuit filename: PB10
3. Assign a compiled circuit name: ACME
4. Answer "no" to the AC input prompts. If you examine ladder circuit PB10, you will see that there are no remote 120 VAC inputs to the SAMMS.
5. After successfully compiling, the new compiled circuit name is displayed.
6. Press any key to return to the main menu.

As an example, assume you are programming a SAMMS3:

SAMMS Version:	3
Control Circuit Number:	1013
Dual Overloads:	N
R.V.A. Starter:	N
Wye-Delta Starter:	N
Part Winding Starter:	N
Local 2-Wire Starter:	Y
NEMA Size:	1
O.L.R. Current Setting:	0.5
Motor Service Factor:	2
Overload Class:	5
Remove Auto Reset Capabilities:	N
Enable Auto Reset:	N
Single Phase Motor:	N
Enable Phase Unbalance Protection:	Y
Enable Incomplete Sequence Protection:	Y

**To download to a SAMMS:**

1. Remove power from the SAMMS.
2. Connect the Download Interface Module to your PC and SAMMS as in Figure 3-3.
3. Connect the power supply to SAMMS terminals 5 and 6 and then to a 120VAC source.
4. Select "DOWNLOAD TO A SAMMS" from the main menu.

**To create a download file:**

1. Select "Make a Download File" from the main menu.
2. Enter the compiled ladder circuit to be linked to the download file: ACME
3. Enter the name you want to assign to your download file: MOTOR\_13
4. Enter the specific motor parameters for your starter.

Refer to the Standard Circuits Manual and the SAMMS User's Manual.

Timer Number 1 Enabled:	Y
Type of Timer Used in Ladder Circuit:	1
Setting:	2
Timer Number 2 Enabled:	Y
Type of Timer Used in Ladder Circuit:	1
Setting:	2
Set Value for Process Current Warning:	90
Enable Jam Protection:	Y
Enable Loss of Load Protection:	Y

After successfully linking your compiled ladder circuit and the motor parameter data, your download filename is displayed. Press any key to continue.

5. Enter your compiled circuit name: ACME
6. Enter your download filename: MOTOR\_13
7. Enter your COM PORT NUMBER (1 or 2)
8. Remove power, and disconnect the download module from the SAMMS.
9. Reapply power to the SAMMS to verify.

[www.ElectricalPartManuals.com](http://www.ElectricalPartManuals.com)

## Siemens Energy & Automation Sales Offices

**Alabama**  
Birmingham  
(205) 879-7030  
Mobile  
(205) 621-0822  
Montgomery  
(205) 271-4486

**Alaska**  
Anchorage  
(907) 346-2489

**Arizona**  
Phoenix  
(602) 944-7900

**Arkansas**  
Little Rock  
(501) 661-9008

**California**  
Fresno  
(209) 264-5018  
Los Angeles  
(714) 979-6600  
Sacramento  
(916) 631-9433  
San Diego  
(619) 569-8015  
San Francisco  
(415) 429-1200  
Stockton  
(209) 478-9596

**Colorado**  
Colorado Springs  
(719) 260-0297  
Denver  
(303) 694-3770  
Ft. Collins  
(303) 223-2712

**Connecticut**  
Wallingford  
(203) 265-5003

**Florida**  
Ft. Lauderdale  
(305) 484-3888  
Fort Myers  
(813) 656-3605  
Jacksonville  
(904) 363-0087  
Miami  
(305) 592-4106  
Orlando  
(407) 894-7771  
Tallahassee  
(904) 422-2885  
Tampa  
(813) 287-2356  
West Palm Beach  
(407) 683-5185

**Georgia**  
Atlanta  
(404) 458-4353  
Macon  
(912) 743-8994  
Savannah  
(912) 354-5092

**Hawaii**  
Honolulu  
(808) 533-7135

**Idaho**  
Boise  
(208) 342-6852

**Illinois**  
Chicago  
(708) 330-4320  
Peoria  
(309) 688-8729  
Rockford  
(815) 229-0092

**Indiana**  
Evansville  
(812) 422-9176  
Fort Wayne  
(219) 483-6999  
Indianapolis  
(317) 788-5500  
Roseland  
(219) 277-7040

**Iowa**  
Davenport  
(319) 359-1357  
Des Moines  
(515) 280-1614

**Kansas**  
Kansas City  
(913) 491-3114  
Wichita  
(316) 942-1409

**Kentucky**  
Louisville  
(502) 426-4647

**Louisiana**  
Baton Rouge  
(504) 293-6874  
New Orleans  
(504) 885-3622  
Shreveport  
(318) 424-0720

**Maine**  
Portland  
(207) 854-0021

**Maryland**  
Landover  
(301) 459-2044

**Massachusetts**  
Boston  
(508) 658-0142  
Springfield  
(413) 562-7994  
Worcester  
(508) 792-4566

**Michigan**  
Grand Rapids  
(616) 247-7611  
Detroit  
(313) 597-7400

**Minnesota**  
Edina  
(612) 942-8888

**Mississippi**  
Jackson  
(601) 936-9360

**Missouri**  
Kansas City  
(913) 491-3114  
St. Louis  
(314) 567-3900  
Sunrise Beach  
(314) 374-2737

**Nebraska**  
Omaha  
(402) 397-1940

**Nevada**  
Las Vegas  
(702) 739-7900

**New Hampshire**  
Manchester  
(603) 623-0701

**New Jersey**  
Union  
(201) 687-7672

**New Mexico**  
Albuquerque  
(505) 881-1611

**New York**  
Albany  
(518) 482-0790  
Buffalo  
(716) 834-3815  
Long Island  
(516) 759-2325  
New York (metro)  
(212) 736-2640  
Syracuse  
(315) 453-3780

**North Carolina**  
Charlotte  
(704) 536-1201  
Greensboro  
(919) 852-1758  
Raleigh  
(919) 782-3365

**North Dakota**  
Bismarck  
(701) 258-9555  
Fargo  
(701) 293-7709

**Ohio**  
Cincinnati  
(513) 891-8717  
Cleveland  
(216) 642-0701  
Columbus  
(614) 766-2204  
Toledo  
(419) 893-7197  
Wooster  
(216) 262-3268

**Oklahoma**  
Oklahoma City  
(405) 235-7515  
Tulsa  
(918) 665-1806

**Oregon**  
Eugene  
(503) 683-2111  
Portland  
(503) 635-6700

**Pennsylvania**  
Erie  
(814) 456-5998  
Philadelphia  
(215) 646-3800  
Pittsburgh  
(412) 788-8060  
York  
(717) 854-9776

**Rhode Island**  
Providence  
(401) 943-6990

**South Carolina**  
Columbia  
(803) 254-7095  
Greenville  
(803) 288-3490

**Tennessee**  
Chattanooga  
(615) 267-7412  
Johnson City  
(615) 282-2718  
Knoxville  
(615) 690-5172  
Memphis  
(901) 761-2123  
Nashville  
(615) 367-9403

**Texas**  
Austin  
(512) 443-7822  
Dallas  
(214) 247-4481  
Fort Worth  
(817) 735-1947  
Houston  
(713) 681-5001  
McAllen  
(512) 687-2072  
San Antonio  
(512) 377-3292

**Utah**  
Salt Lake City  
(801) 272-2090

**Virginia**  
Richmond  
(804) 288-8311  
Roanoke  
(703) 982-2776  
Virginia Beach  
(804) 486-0174

**Washington**  
Seattle  
(206) 828-6600  
Spokane  
(509) 325-2582

**Washington, D.C.**  
(301) 459-2044

**Wisconsin**  
Milwaukee  
(414) 774-9500  
Green Bay  
(414) 336-1144

**Canada**  
Mississauga,  
Ontario  
(416) 564-1995  
Pointe Claire,  
Quebec  
(514) 695-7300  
Vancouver,  
British Columbia  
(604) 321-8687

**International**  
TLX: 822024SEA IBU U  
Fax: (404) 740-3996