

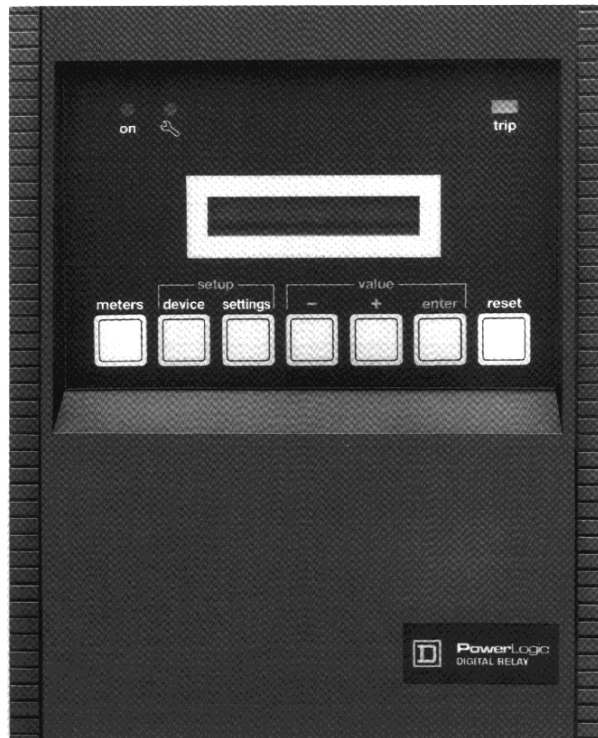

# PowerLogic<sup>®</sup>

## Digital Relay

Class 3030



## NOTICE

Read these instructions carefully and look at the equipment to become familiar with the device before trying to install, operate, or maintain it. The following special messages appear throughout this bulletin to warn of potential hazards.

### **DANGER**

Used where there is a hazard of severe bodily injury or death. Failure to follow a "DANGER" instruction *will* result in *severe* bodily injury or death.

### **WARNING**

Used where there is a hazard of bodily injury or death. Failure to follow a "WARNING" instruction could result in bodily injury or death.

### **CAUTION**

Used where there is a hazard of equipment damage. Failure to follow a "CAUTION" instruction may result in damage to equipment.

**FCC NOTICE:** This equipment complies with the requirements in Part 15 of FCC rules for a Class A computing device. Operation of this equipment in a residential area may cause unacceptable interference to radio and TV reception, requiring the operator to take whatever steps are necessary to correct the interference.

## **TECHNICAL SUPPORT**

**For technical support, contact the Power Monitoring and Control Systems Technical Support Center.  
Hours are 7:30 A.M. to 4:30 P.M., Central Time, Monday through Friday.  
Phone: (615) 459-8552 Fax: (615) 459-4294**

Square D, POWERLOGIC, SY/MAX, SY/NET, SY/LINK, VISI/VAC, and  are Registered Trademarks of Square D Company.

© 1995 Square D, all rights reserved. This bulletin may not be copied in whole or in part, or transferred to any other media, without the written permission of Square D Company.

**CONTENTS**

1. INTRODUCTION .....	1
Description .....	1
Front Panel .....	2
Rear Panel .....	3
Notational Conventions .....	5
2. SAFETY PRECAUTIONS .....	7
3. RECEIVING, HANDLING, AND STORAGE .....	9
Receiving .....	9
Handling .....	10
Storage .....	10
4. INSTALLATION .....	11
Tools Required .....	11
Digital Relay Installation .....	12
5. DIP SWITCH SETTINGS .....	15
Introduction .....	15
Setting the DIP Switches .....	15
Selecting 1 A CT or 5 A CT Operating Mode .....	16
Selecting the Ground Fault Current Sensing Mode .....	16
6. WIRING .....	17
Introduction .....	17
Card and Terminal Identification .....	17
Card Components .....	18
Wiring Terminal Blocks .....	18
Card 1 Wiring .....	20
Card 2 Wiring .....	22
Card 3 Wiring (Communications) .....	26
Status Input Connections .....	31
7. FRONT PANEL OPERATION .....	33
Front Panel .....	33
Energizing .....	33
Modes .....	34
Settings and Metered Values .....	34
Setup Mode .....	35
Standard Mode .....	38
Messages .....	40
8. COMMISSIONING .....	43
Introduction .....	43
Dielectric Testing .....	43
Energizing .....	44
General Device Setup .....	44
Test Methods .....	45
Metering .....	48
ANSI 50/51, and either 50N/51N or 50G/51G Setting and Testing .....	50

9. MAINTENANCE AND TROUBLESHOOTING .....	67
Maintenance .....	67
Getting Technical Support.....	67
Troubleshooting .....	67

## APPENDICES

Appendix A—Specifications .....	69
Appendix B—Glossary .....	71
Appendix C—Communication Cable Pinouts .....	73
Appendix D—CSH Core Balance CTs .....	74
Appendix E—Ground Fault Current Measurement Method Summary .....	79
Appendix F—Default Settings .....	80
Appendix G—Rear Cover .....	81
Appendix H—Ordering Information .....	82
Appendix I—Setting Scale Factors for Extended Metering Ranges .....	83
Appendix J—Abbreviated Register Listing .....	85
Appendix K—Command Interface .....	96
Appendix L—Terminal Block Wiring Specifications .....	100
Appendix M—Installation and Test Log .....	101

## ILLUSTRATIONS

1. POWERLOGIC Digital Relay .....	1
2. POWERLOGIC Digital Relay front panel .....	2
3. POWERLOGIC Digital Relay rear panel .....	3
4. Digital relay identification label .....	9
5. Phase current sensor module (CCA 650) .....	10
6. 8-position removable terminal block (CCA 608) .....	10
7. 6-position removable terminal block (CCA 606) .....	10
8. 4-position removable terminal block (CCA 604) .....	10
9. Mounting brackets .....	10
10. Digital relay dimensions .....	12
11. Installing the digital relay in equipment panel .....	13
12. Rear view of digital relay installed in panel .....	13
13. DIP switches are located in card 2 on rear panel .....	15
14. DIP switch settings .....	15
15. SW2 setting for 5 A CTs (default setting) .....	16
16. SW2 setting for 1 A CTs .....	16
17. Ground fault current sensing mode DIP switch location .....	16
18. SW1 setting for current measurement by internal summation of phase currents .....	16
19. Cards on models DR-LXS01 S0A TBN and DR-LXS01 S0A TEN; terminal identification .....	17
20. Card components on digital relay rear panel .....	18
21. Installing 8-position removable terminal block .....	19
22. Card 1 wiring .....	20
23. Control power wiring for digital relay ac and dc models .....	21
24. CCA 650 wiring example (for 5 A CTs with internal summation for ground fault) .....	22
25. Securing a phase wire eye lug to the phase current sensor module .....	24
26. Attaching phase current sensor module to digital relay .....	24
27. Tightening phase current sensor module connector screws .....	24
28. Series-connected wiring of the phase current sensor module .....	25

29. Communications card .....	26
30. Multiple POWERLOGIC device types on a communications link .....	26
31. RS-485 communication wiring .....	27
32. Connecting the digital relay as the first device on a POWERLOGIC communications link .....	28
33. RS-485 terminator placement .....	30
34. Connecting the RS-485 terminator to a digital relay .....	31
35. Typical status input connections .....	31
36. Front panel .....	33
37. Pages available on digital relay .....	34
38. Navigating digital relay <i>meters</i> pages .....	35
39. Location of parameter setup mode access hole (marked <i>P</i> ) .....	35
40. “* Device *” displayed .....	36
41. Original PH CT setting .....	36
42. New setting flashes .....	36
43. New setting stored; stops flashing .....	36
44. “CHECK SETTINGS” message .....	38
45. <i>meters</i> button location .....	38
46. Phase A current measurement .....	38
47. Phase B trip current measurement .....	38
48. Ground fault trip current measurement .....	39
49. Maximum trip current measurement .....	39
50. <i>device</i> button location .....	39
51. <i>settings</i> button location .....	39
52. <i>reset</i> button location .....	40
53. Example of phase A injection .....	46
54. Time delay measurement .....	47
55. Definite time curve .....	50
56. Inverse-time-overcurrent curve .....	50
57. Definite time (DT) curve .....	52
58. Rapid inverse (RI) curve .....	52
59. Standard inverse time (SIT) curve .....	53
60. Very inverse time (VIT) curve .....	53
61. Extremely inverse time (EIT) curve .....	54
62. Ultra inverse time (UIT) curve .....	54
63. Instantaneous pickup check .....	57
64. Time-overcurrent pickup check .....	57
65. Time delay check (10 x PH CS) .....	58
66. Curve type check (2 x PH CS) .....	58
67. Instantaneous time delay check .....	58
68. Definite time curve .....	60
69. Inverse-time-overcurrent curve .....	60
70. Pickup too low .....	61
71. Ground fault time delay shorter than phase time delay .....	61
72. Instantaneous pickup check .....	62
73. Overcurrent pickup check .....	63
74. Time delay check (10 x GF CS) .....	63
75. Curve type check (2 x GF CS) .....	63
76. Instantaneous time delay check .....	63
77. SW1 setting for ground fault current measurement by external core balance CT .....	74
78. Connecting digital relay with a CSH core balance CT for the 2 A rating .....	75
79. Connecting digital relay with a CSH core balance CT for the 30 A rating .....	75
80. CSH 30 interposing CT with five turns of a 1 A secondary lead .....	76
81. Digital relay connected to a standard 1 A zero sequence CT .....	76
82. CSH 30 interposing CT with one turn of a 5 A secondary lead .....	76

### ILLUSTRATIONS (cont.)

83. Digital relay connected to a standard 5 A zero sequence CT .....	76
84. CT assembly mounted on MV cable .....	77
85. CT assembly mounted on frame .....	77
86. CT assembly mounted vertically on symmetric DIN rail .....	77
87. CT assembly mounted horizontally on symmetric DIN rail .....	77
88. Incorrect and correct methods of grouping MV cables together in center of core balance CT .....	78
89. Optional rear cover .....	81
90. Digital relay dimensions with rear cover installed .....	81
91. Dual microprocessor scheme (communicating digital relays) .....	85
92. Communications card jumpers .....	96
93. Possible jumper combinations and features supported .....	97

### TABLES

1. Digital Relay Model Numbers .....	1
2. Typical Digital Relay Mounting Locations .....	13
3. Maximum Distance of Communications Link at Different Baud Rates .....	28
4. Labeling the CAB-107 Leads .....	29
5. Display Parameters .....	39
6. Alarm Messages .....	41
7. Trip Messages .....	41
8. Measurement Characteristics .....	48
9. 3-Phase Overcurrent Parameter Settings .....	51
10. Induction Disc Amp Tap/Digital Relay Current Setting Equivalents .....	51
11. Digital Relay K Values .....	56
12. ANSI 50/51 Installation Characteristics .....	58
13. 3-Phase Overcurrent Test Results .....	59
14. Ground Fault Overcurrent Parameter Settings .....	61
15. ANSI 50N/51N or 50G/51G Installation Characteristics .....	64
16. Ground Fault Overcurrent Test Results .....	65
17. Troubleshooting .....	68
18. Ground Fault Current Measurement Method Summary .....	79
19. Digital Relay Accessories .....	82
20. Available Scale Factors .....	83
21. Scale Factor Values .....	84
22. Command Codes .....	97
23. Command Result Codes .....	98
24. Date/Time Information .....	99
25. Terminal Block Wiring Specifications .....	100

## CHAPTER 1—INTRODUCTION

### DESCRIPTION

The POWERLOGIC® Digital Relay (figure 1) is a multifunction, microprocessor-based device which performs these functions:

- provides ANSI 50/51, and either 50N/51N or 50G/51G relay functions
- optional latching of output relay contacts (ANSI 86)
- controls and monitors the associated circuit breaker or contactor
- measures phase and ground currents
- displays operating messages
- provides remote monitoring through optional communications

### Model Numbers

Table 1 below lists and briefly describes each digital relay model.

**Table 1**  
**Digital Relay Model Numbers**

Description	Model Number
48–125 Vdc Power Supply—No Communications	DR-LXS01 X0A TBN
100–127 Vac Power Supply—No Communications	DR-LXS01 X0A TEN
48–125 Vdc Power Supply—POWERLOGIC Communications	DR-LXS01 S0A TBN
100–127 Vac Power Supply—POWERLOGIC Communications	DR-LXS01 S0A TEN

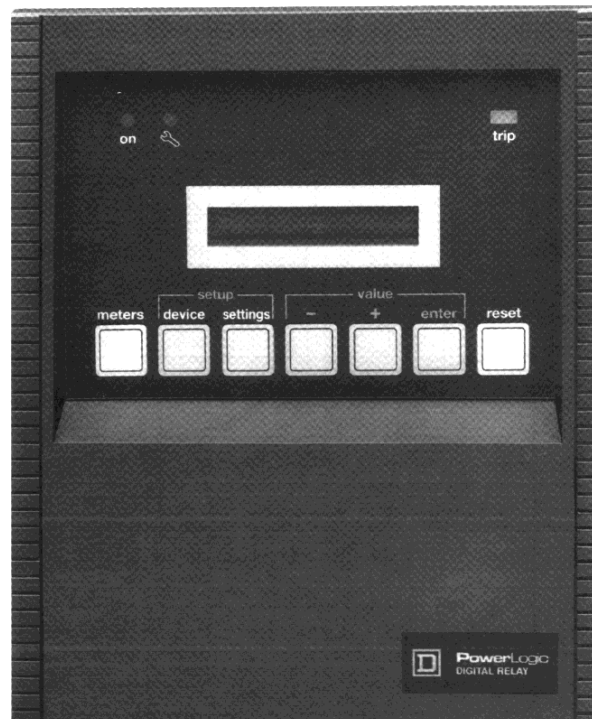

*Figure 1: POWERLOGIC Digital Relay*

## FRONT PANEL

The front panel consists of three sections. Each is detailed below and referenced in figure 2.

### Status Indicators

The status indicators consist of the following components:

- The green *on* LED (1) which lights when the digital relay is energized.
- The red self-diagnostic LED above the wrench icon (2). This LED lights if an internal fault occurs within the digital relay. At this point, the digital relay is out of service and requires maintenance. As a result, all the output relays are inhibited. See **Maintenance And Troubleshooting**, page 67, for more information.
- The red *trip* indicator (3). This indicator lights when the digital relay operates a circuit breaker after detecting a fault current. A trip message displays, indicating the fault type.

### Display

The display unit (4) displays the following:

- phase ammeter readings
- phase demand ammeter readings
- phase/ground amperes at time of last trip
- all setup values
- messages

### Keyboard

The keyboard (5) consists of seven buttons. Use these buttons to advance through the digital relay display menus.

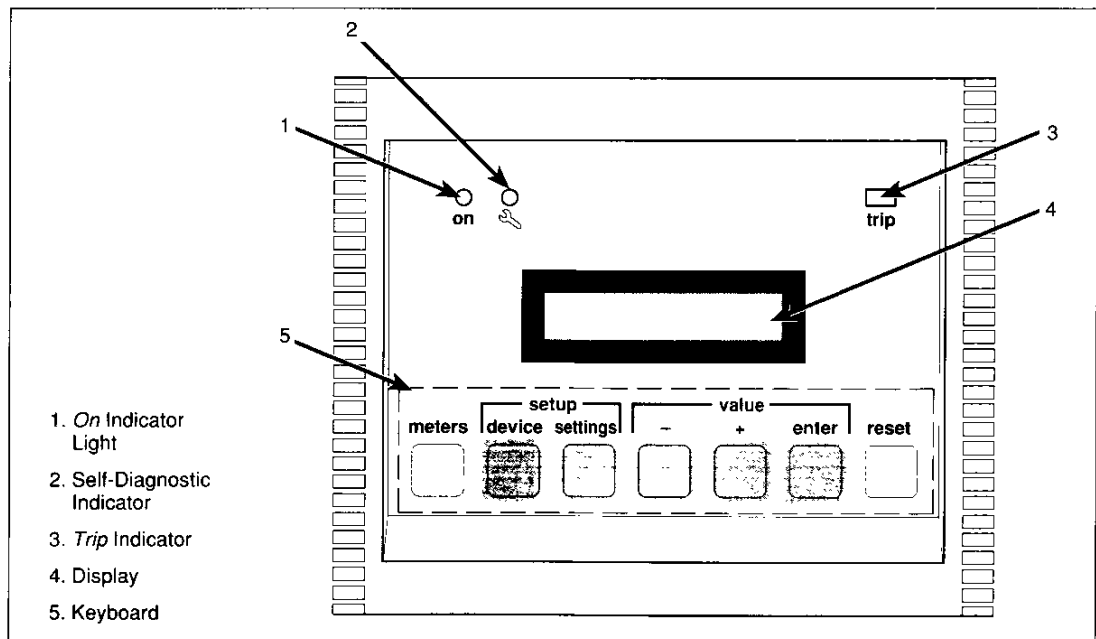

Figure 2: POWERLOGIC Digital Relay front panel

**REAR PANEL**

Components of the digital relay rear panel are shown below in figure 3. For all numbered references to rear panel components, refer to figure 3.

**Protective Output Relay Contacts**

The digital relay has three output relay contacts (1), which operate when a phase fault or ground fault is detected:

- output 1—terminals 8 and 7 (normally open)
- output 2—terminals 6 and 5 (normally open)
- output 3—terminals 4 and 3 (normally closed)

These relays connect to the trip circuit.

**Control Power**

Both ac and dc models of the digital relay are available. The dc model of the digital relay supports 48–125 Vdc power supplies; the ac model supports 100–127 Vac power supplies.

The control power is connected to the two control power terminals and the grounding screw (2).

**Parameter Setup Mode Access Hole**

Pressing the button located in the parameter setup mode access hole *P* (3) activates the parameter setup mode. The digital relay settings are entered in this mode using the *value +* and *value -* buttons.

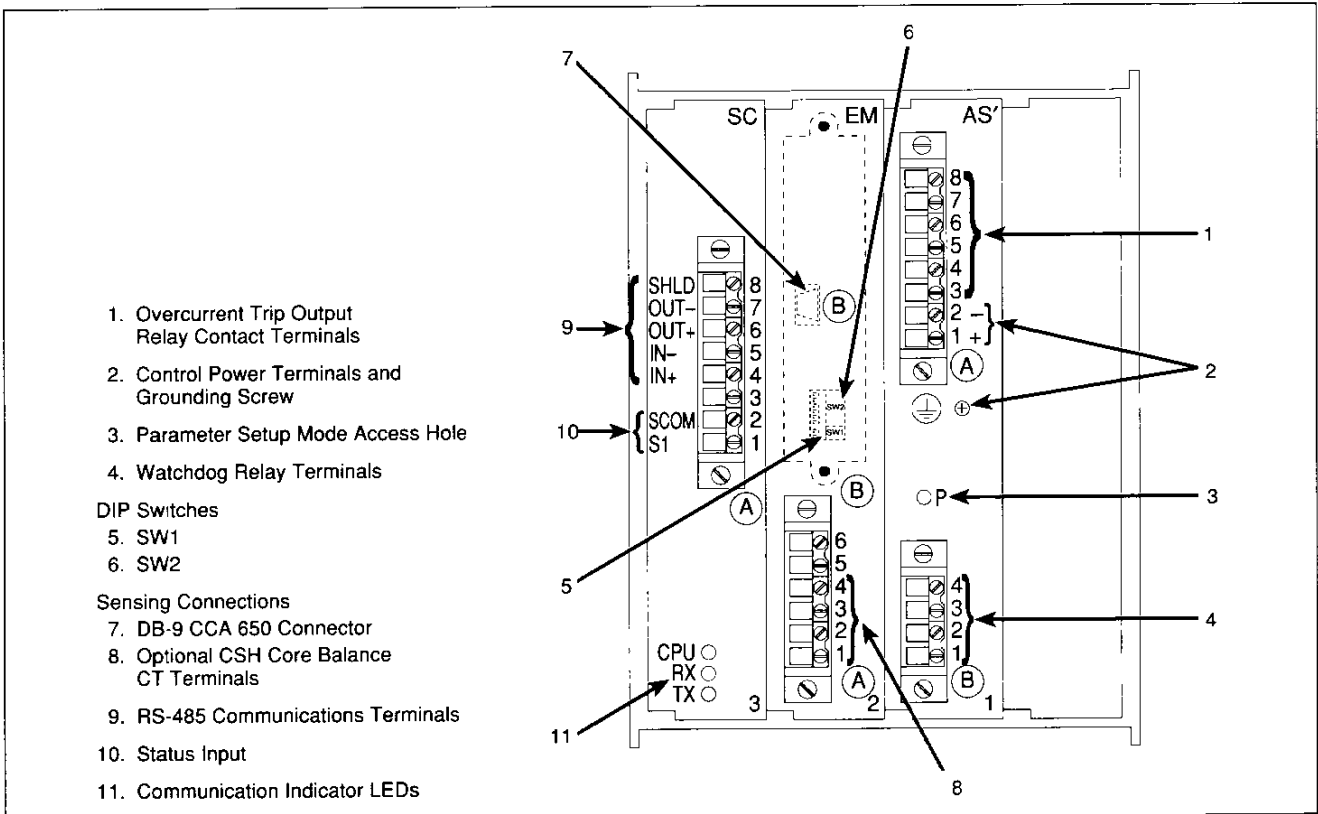

Figure 3: POWERLOGIC Digital Relay rear panel

### **Watchdog Relay**

The digital relay continually performs a self-diagnostics check. If the unit detects an internal failure, the protective output relay contacts are then inhibited and a watchdog relay operates. The watchdog relay consists of two output relay contacts (4):

- output 4—terminals 4 and 3 (normally open)
- output 5—terminals 2 and 1 (normally closed)

The watchdog output relay contacts can be connected to an alarm (e.g., a light or a bell) to indicate when an internal failure occurs.

### **DIP Switches**

There are two sets of DIP switches on the back of the relay. The DIP switches must be set before the CCA 650 phase current sensor module is attached to the digital relay. The DIP switches are used as follows:

- SW1 (5), 2-position, is used to select the method of ground fault measurement to be used
- SW2 (6), 6-position, is used to select whether 1 A or 5 A standard CTs will be used for phase current sensing

### **Sensing Connections**

The line currents are sensed by three external 1 A or 5 A standard phase CTs. The CT secondary leads are connected to the CCA 650 phase current sensor module, which contains the digital relay current sensors and attaches to the rear of the digital relay by the DB-9 connector (7).

There are two methods for sensing the ground fault current:

- internal summation of the three phase currents (default)
- an optional method using an external CSH core balance CT connected to the back of the digital relay (8); the CSH core balance CT is purchased separately

### **Communications**

The POWERLOGIC communicating version of the digital relay has the following capabilities:

- POWERLOGIC software compatibility
- can share RS-485 communications link (9) with circuit monitors
- operates at a baud rate from 1,200 to 19,200 bps
- can be daisy-chained with up to 31 additional POWERLOGIC devices over a 10,000 foot (3,048 m) span

### **Status Input**

There is one status input for remote status monitoring (10).

### **Communication Indicator Lights**

There are three communication indicator lights (11), which show the status of the optional communications card as follows:

- red CPU LED alternates one second on/one second off when the communications card central processing unit (CPU) is operating normally
- yellow RX LED flashes when a master device is sending a message to a device on the network
- green TX LED flashes when the digital relay is acknowledging a message it received

**NOTATIONAL  
CONVENTIONS**

This bulletin uses the following notational conventions:

- Labeled digital relay component names, such as the *device* button or the *trip* LED, are italicized.
- Settings and readings which appear on the digital relay display are in quotation marks, with capitalization matching the display. Some examples are "PH CT = 100 A," "CHECK SETTINGS," and "GS CS = off." In graphics showing digital relay display readings, the quotation marks are omitted.
- Tasks you must perform begin with a statement of the task (e.g., Follow these steps to check the current setting:), followed by a numbered list of steps.
- Bulleted lists, like this one, provide information but do not require you to take action.
- Cross-references to other sections in the document appear in boldface. Example: refer to **Setting Parameters**, page 35.
- Notes consist of important information relevant to the topic at hand. Notes are in italic type, with the word **Note** in bold italic.
- Danger, Warning, and Caution notices and the hazard level of each are explained on the inside front cover of this bulletin.



## CHAPTER 2—SAFETY PRECAUTIONS

### **DANGER**

#### **HAZARD OF ELECTRIC SHOCK, BURN, OR EXPLOSION.**

- Only qualified electrical workers should install this equipment. Such work should be performed only after reading this entire set of instructions.
- The successful operation of this equipment depends upon proper handling, installation, setup, and operation. Neglecting fundamental installation requirements will lead to personal injury as well as damage to electrical equipment or other property.
- Before performing visual inspections, tests, or maintenance on this equipment, disconnect all sources of electrical power. Assume that all circuits are live until they have been completely de-energized, tested, grounded, and tagged. Pay particular attention to the design of the power system. Consider all sources of power, including the possibility of backfeeding.

Failure to follow these precautions will result in electric shock, severe personal injury, or death!



**CHAPTER 3—RECEIVING, HANDLING, AND STORAGE****RECEIVING**

Inspect each container for external damage or indications of rough handling before accepting the shipment. If there is external damage, or if the correct number of boxes is not received, note the problem on the shipping papers before signing them.

Upon receipt, open each container and inspect the contents for damage. Check the packing list against the equipment received to ensure the order is complete. Check the numbers listed on the digital relay identification label (figure 4) against those on the packing list.

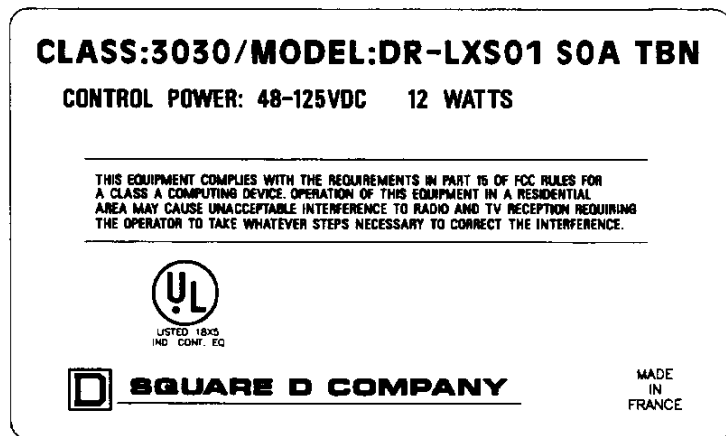

Figure 4: Digital relay identification label

## RECEIVING (cont.)

Each standard digital relay package should contain the following components:

- digital relay
- phase current sensor module CCA 650 (figure 5)
- 8-position removable terminal block CCA 608 (figure 6)
- 6-position removable terminal block CCA 606 (figure 7)
- 4-position removable terminal block CCA 604 (figure 8)
- two mounting brackets (figure 9)

The communicating version of the digital relay includes a second 8-position removable terminal block CCA 608 (figure 6) and a 5-position screw terminal block (not shown) for connecting a Multipoint Communications Terminator (MCT-485).

If the shipment is damaged or incomplete, immediately file a claim with the carrier. Notify your local Square D field office about the extent of damages or shortages, and attach a copy of the formal damage claim.

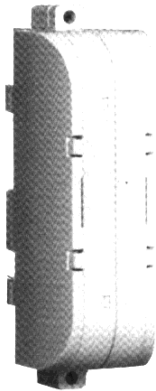

Figure 5: Phase current sensor module (CCA 650)

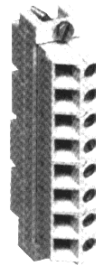

Figure 6: 8-position removable terminal block (CCA 608)

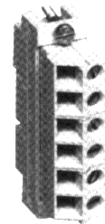

Figure 7: 6-position removable terminal block (CCA 606)

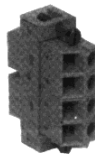

Figure 8: 4-position removable terminal block (CCA 604)

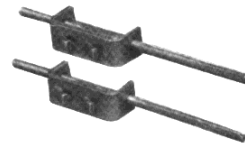

Figure 9: Mounting brackets

## HANDLING

Avoid rough handling of the digital relay.

## STORAGE

If the digital relay is stored prior to installation, store it in a dry place where it is protected from mechanical abuse. Store the unit in its shipping container. The storage temperature range is  $-13^{\circ}\text{F}$  to  $+158^{\circ}\text{F}$  ( $-25^{\circ}\text{C}$  to  $+70^{\circ}\text{C}$ ).

**CHAPTER 4—INSTALLATION****⚠ DANGER****HAZARD OF ELECTRIC SHOCK, BURN, OR EXPLOSION.**

- Only qualified electrical workers should install this equipment. Such work should be performed only after reading this entire set of instructions.
- The successful operation of this equipment depends upon proper handling, installation, setup, and operation. Neglecting fundamental installation requirements will lead to personal injury as well as damage to electrical equipment or other property.
- Before performing visual inspections, tests, or maintenance on this equipment, disconnect all sources of electrical power. Assume that all circuits are live until they have been completely de-energized, tested, grounded, and tagged. Pay particular attention to the design of the power system. Consider all sources of power, including the possibility of backfeeding.
- Before installing the digital relay in switchgear or circuit breaker enclosures, de-energize the switchgear or circuit breaker.

Failure to follow these precautions will result in electric shock, severe personal injury, or death!

**TOOLS REQUIRED**

To install the digital relay, you will need the following:

- ruler or other measuring device
- felt-tip pen or similar marking device
- drill or metal punch
- jig saw equipped with metal-cutting blade
- torque screwdrivers—Phillips-head and flathead

## DIGITAL RELAY INSTALLATION

The digital relay is a semi-flush-mounted device that projects through the back of a panel or circuit breaker cell door. Mounting dimensions are shown in figure 10.

When choosing a mounting location, consider these points:

- Allow for easy access to the rear of the digital relay.
- Allow extra space for all wires, shorting blocks, or other components.
- Depth of the digital relay. Refer to figure 10 for digital relay dimensions, and figure 89, page 81, for dimensions of the optional rear cover.
- Do not block the ventilation openings on the top and bottom of the unit; leave ventilation space of at least 2" (51 mm) above and below the digital relay.
- Ensure ambient conditions are within the acceptable range: operating temperature  $-5$  to  $+55^{\circ}\text{C}$  ( $+23^{\circ}\text{F}$  to  $131^{\circ}\text{F}$ ); relative humidity 5–95% non-condensing (see **Specifications**, page 69)

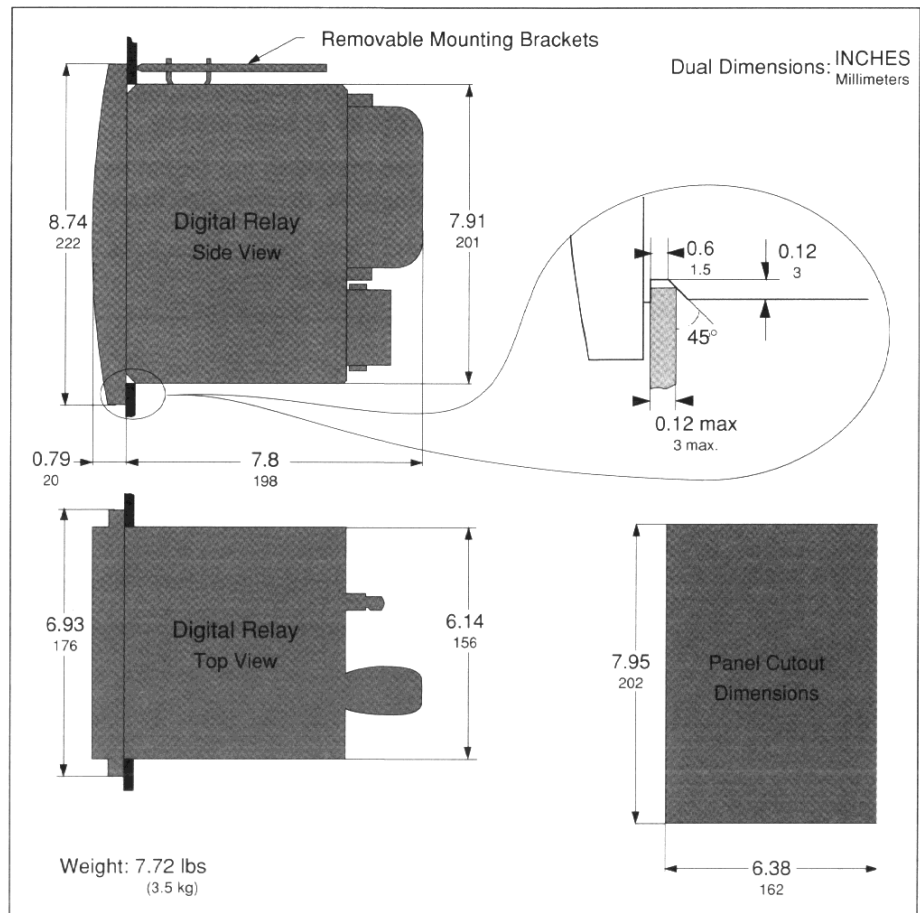

Figure 10: Digital relay dimensions

## DIGITAL RELAY INSTALLATION (cont.)

The digital relay is designed for flush-mounting on a panel less than 0.12" (3 mm) thick (see figure 10). Follow these steps to install the digital relay in the panel:

1. Select the mounting location. See table 2 for typical mounting locations.

**Table 2**  
**Typical Digital Relay Mounting Locations**

Equipment Type	Mounting Location
VISI/VAC® Switchgear	Instrument Door
Metal-Clad and Substation Ckt. Bkrs.	Standard Relaying Locations

2. Referring to figure 10, prepare the cutout.
3. Insert the digital relay through the cutout; seat the two notches at the bottom of the digital relay (1, figure 11) onto the panel sheet metal. (A close-up of these notches is shown in the inset in figure 10, page 12.)
4. Position the two mounting brackets in the holes on the top of the digital relay case.
5. Tighten the threaded studs of the brackets (2, figure 11) until they are firmly against the back of the panel (figure 12).

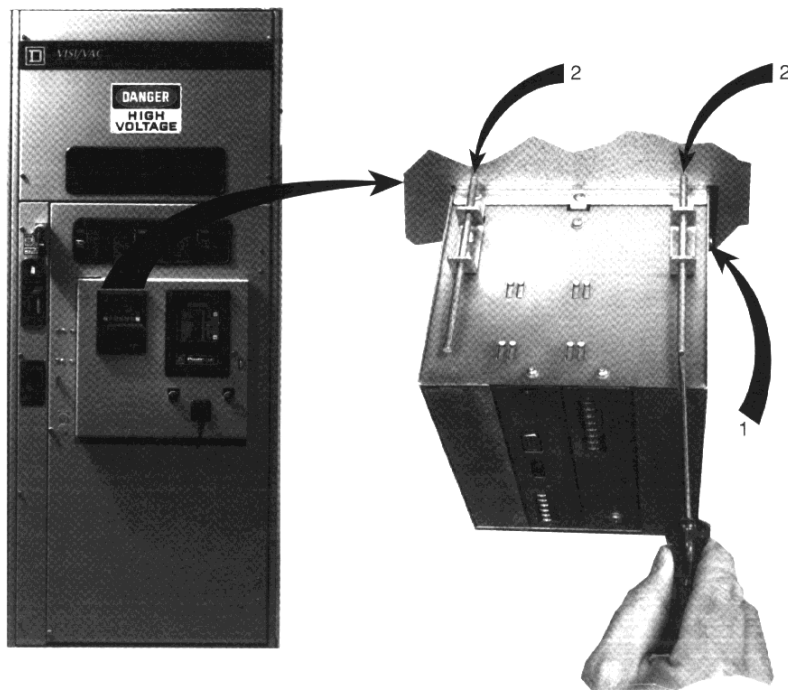

Figure 11: Installing the digital relay in equipment panel

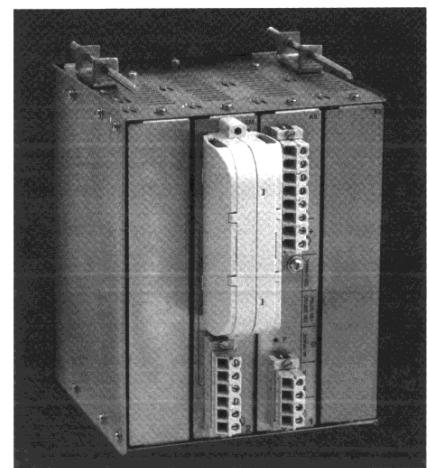

Figure 12: Rear view of digital relay installed in panel



## CHAPTER 5—DIP SWITCH SETTINGS

### INTRODUCTION

The digital relay supports a variety of operating modes. These modes are selected using DIP switches located in card 2 on the back of the digital relay.

### ! WARNING

#### HAZARD OF ELECTRIC SHOCK OR BURN.

- DIP switches must be set before attaching the CCA 650 phase current sensor module to the digital relay. Failure to correctly set DIP switches before attaching the phase current sensor module can result in unintended operation of the trip output contacts.
- Ensure the DIP switches are pushed completely to the left or to the right. Switches in in-between positions will result in random settings.

Failure to follow this precaution could result in electric shock, severe personal injury, death, or equipment damage!

### SETTING THE DIP SWITCHES

The digital relay has two groups of DIP switches for setting the analog input operating mode: SW1 and SW2 (figure 13).

The DIP switches in each group are numbered from top to bottom. When a DIP switch is set to the left, its status is 0. When a DIP switch is set to the right, its status is 1 (figure 14).

*Note:* De-energize the digital relay before changing the position of the operating mode DIP switches.

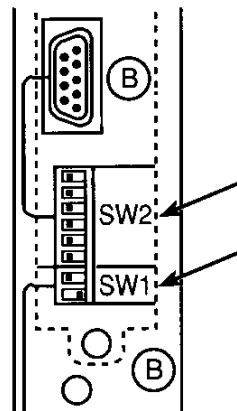
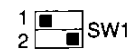

Figure 13: DIP switches are located in card 2 on rear panel

Example:



SW1 DIP Switch 1 Is Set To 0  
SW1 DIP Switch 2 Is Set To 1

Figure 14: DIP switch settings

**SELECTING 1 A CT OR  
 5 A CT OPERATING MODE**

The digital relay can operate with 1 A or 5 A CTs. Select the rating using the six SW2 DIP switches on the rear panel of the digital relay. For 5 A CT operation, set the DIP switches as shown in figure 15. For 1 A CT operation, set the DIP switches as shown in figure 16.

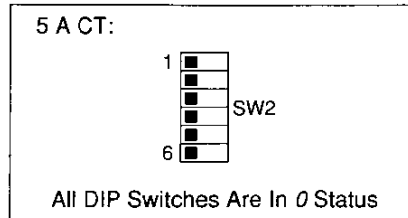

Figure 15: SW2 setting for 5 A CTs (default setting)

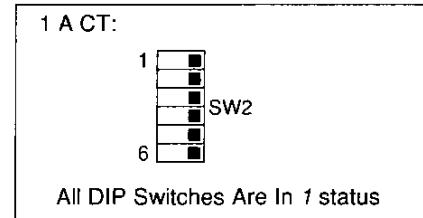

Figure 16: SW2 setting for 1 A CTs

**SELECTING THE  
 GROUND FAULT CURRENT  
 SENSING MODE**

The digital relay measures ground fault current by internal vector summation of the phase currents. (Ground fault current can also be measured by using an optional core balance CT; see Appendix D—CSH Core Balance CTs, page 74, for information on using core balance CTs.)

Set the measurement mode using the SW1 DIP switches located on the rear of the digital relay. Figure 17 shows the SW1 switch location on the back of the digital relay. Figure 18 shows the SW1 switch setting for current measurement by internal summation of phase currents.

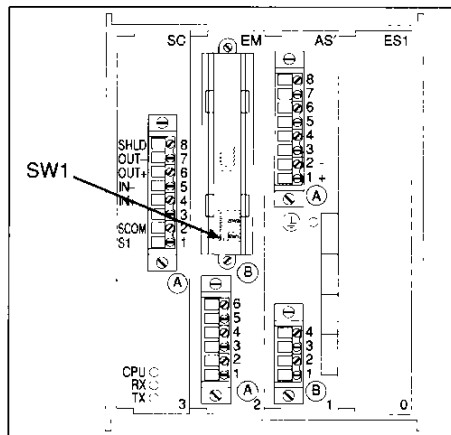

Figure 17: Ground fault current sensing mode DIP switch location

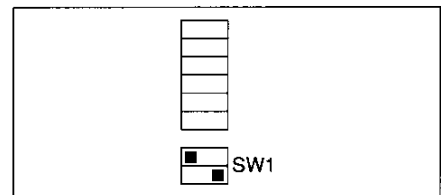

Figure 18: SW1 setting for current measurement by internal summation of phase currents

**CHAPTER 6—WIRING**

**⚠ DANGER**

**HAZARD OF ELECTRIC SHOCK, BURN, OR EXPLOSION.**

- Turn off all power supplying equipment before making connections.
- Only qualified electrical workers should install this equipment. Such work should be performed only after reading this entire set of instructions.
- The successful operation of this equipment depends upon proper handling, installation, setup, and operation. Neglecting fundamental installation requirements will lead to personal injury as well as damage to electrical equipment or other property.

Failure to follow these precautions will result in electric shock, severe personal injury, or death!

**INTRODUCTION**

This section identifies the components located on the rear of the digital relay. It also explains general wiring of the digital relay, the phase current sensor module, communications, and the status input.

**CARD AND TERMINAL IDENTIFICATION**

Four sections, called cards, comprise the rear panel of the digital relay. Figure 19 shows the location and briefly describes the function of each card. Each terminal on the rear panel of the digital relay is identifiable by a 3-character reference. Figure 19 (inset) illustrates how the 3-character reference is derived.

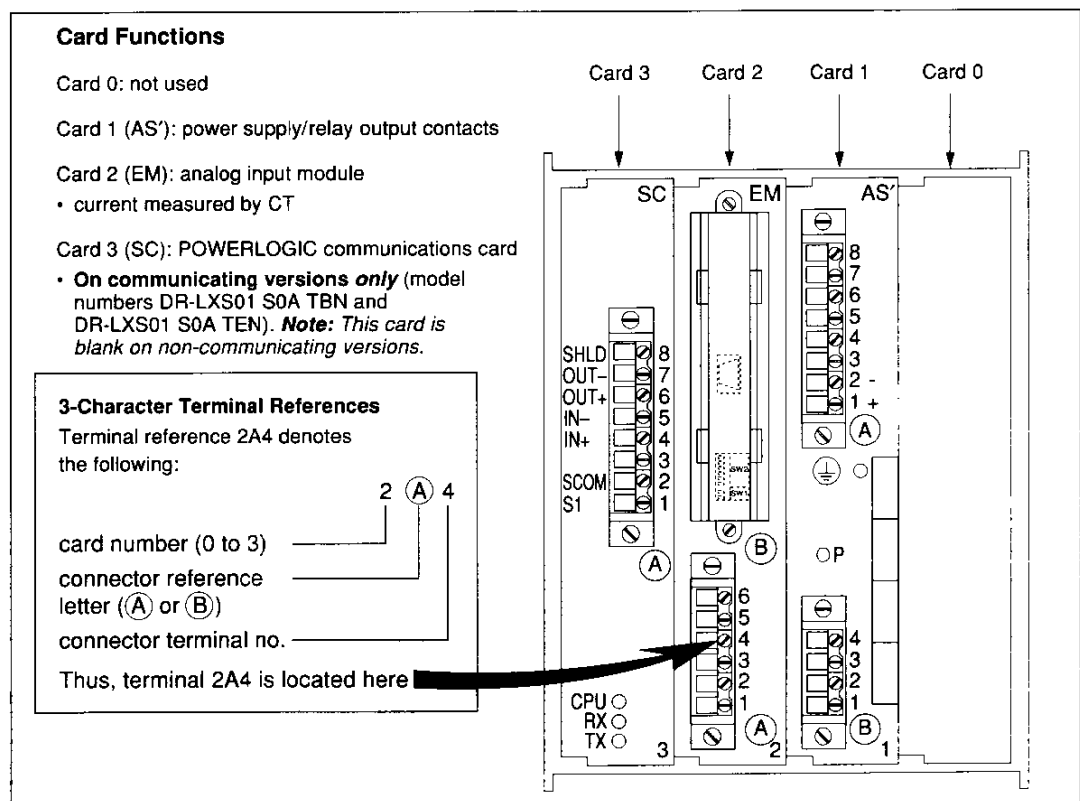

Figure 19: Cards on models DR-LXS01 S0A TBN and DR-LXS01 S0A TEN; terminal identification

**CARD COMPONENTS**

Figure 20 identifies the card components on the digital relay rear panel and outlines wire ranges for the various terminal blocks.

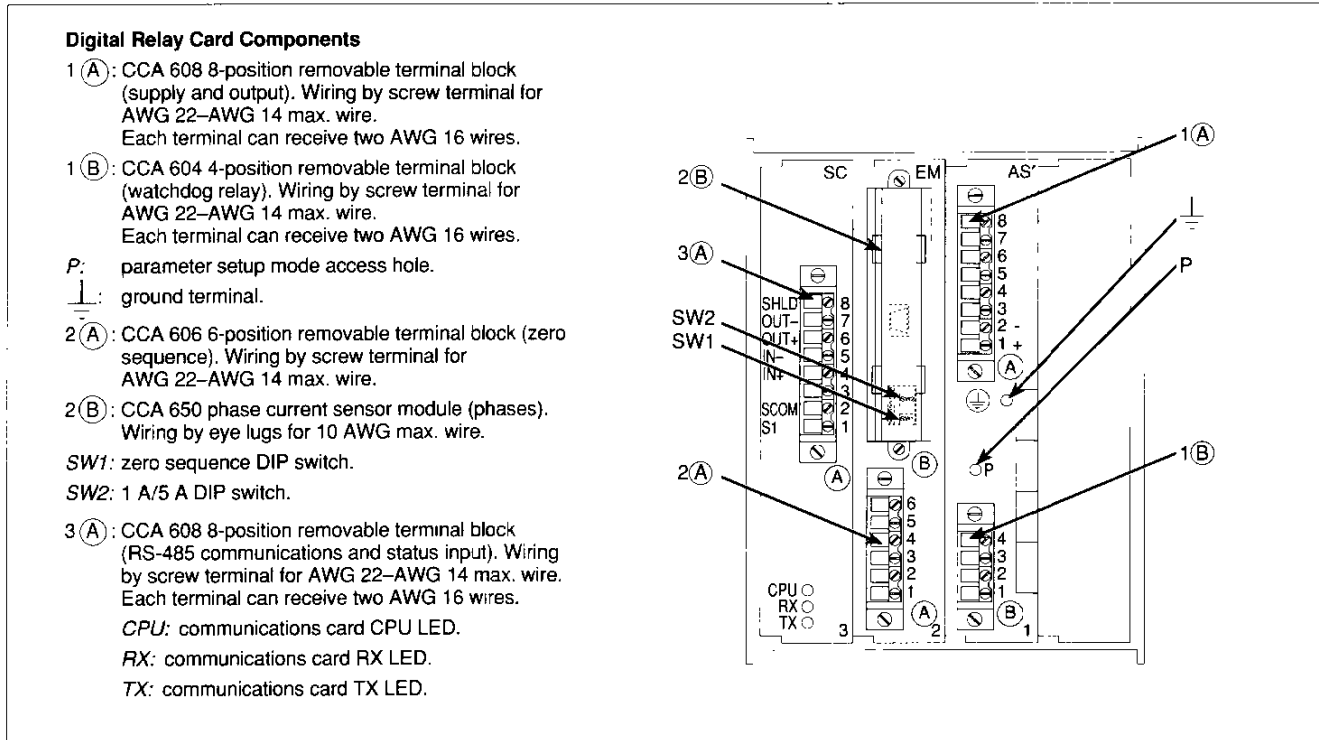

Figure 20: Card components on digital relay rear panel

**WIRING TERMINAL BLOCKS**

**⚠ DANGER**

**HAZARD OF ELECTRIC SHOCK, BURN, OR EXPLOSION.**

- Turn off all power supplying this equipment before making connections.
- Only qualified electrical workers should install this equipment. Such work should be performed only after reading this entire set of instructions.
- The successful operation of this equipment depends upon proper handling, installation, setup, and operation. Neglecting fundamental installation requirements will lead to personal injury as well as damage to electrical equipment or other property.

Failure to follow these precautions will result in electric shock, severe personal injury, or death!

This section covers general wiring of terminal blocks. Specific instructions and examples for wiring each card follow on pages 20–31. Read this section and per-card wiring instructions *before* performing any wiring.

**WIRING TERMINAL BLOCKS  
(cont.)**

*Note: The length of insulation to be stripped from each wire varies depending on wire gauge and the number of wires to be installed in a terminal block slot. These variables also affect terminal block screw torque values. Before wiring any terminal block, refer to the Terminal Block Wiring Specifications table, page 100. Note any special instructions.*

All digital relay connections, except those made on the current sensor module (described on pages 22–25), are made on the removable terminal blocks on the rear of the unit. The terminal blocks have locking screws. Wires connected to terminals on these blocks must be in the AWG 22–AWG 14 range.

*Note: If two wires (maximum) are connected to any one terminal, neither wire can exceed 16 AWG.*

Follow these steps to wire terminal blocks:

1. Use wire of the correct gauge for the application.
2. Referring to the **Terminal Block Wiring Specification** table, page 100, carefully strip the correct length of insulation from the end of the wire to be connected.
3. Insert the stripped wire into the correct numbered slot on the left side of the terminal block. After fully inserting the stripped wire, use a flathead screwdriver to tighten the corresponding screw at the right of the slot, locking the wire in place. Refer to the **Terminal Block Wiring Specifications** table, page 100, for the correct torque range.

**CAUTION****HAZARD OF EQUIPMENT DAMAGE.**

**Do not overtighten the terminal block locking screws or the terminal block retaining screws; overtightening could crack a terminal block and sever wires.**

Failure to observe this precaution can result in equipment damage.

4. Insert the terminal block into its receptacle on the rear of the digital relay.
5. Tighten the terminal block retaining screws on the digital relay rear panel to 6–9 lb-in (0.68–1 N•m); see figure 21 below.

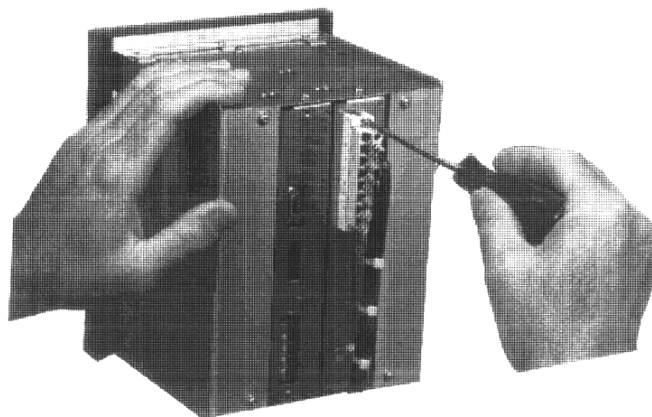

Figure 21: Installing 8-position removable terminal block

## CARD 1 WIRING

Figure 22 below illustrates the card 1 output contacts in their normal position.

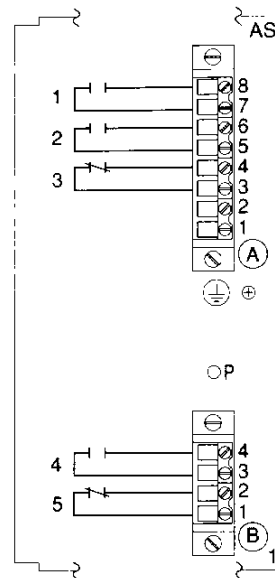

Figure 22: Card 1 wiring

### Wiring the Protective Output Relay Contacts

The digital relay has three output relay contacts which operate simultaneously when a phase overcurrent or ground fault is detected. Connect the contacts to the trip circuit, referring to figure 22 and the following contact specifications:

- output 1—terminals 8 and 7 (normally open)
- output 2—terminals 6 and 5 (normally open)
- output 3—terminals 4 and 3 (normally closed)

*Note: All of the trip output relay contacts listed above are located on terminal block A, card 1.*

### Control Power Wiring

Using a braid or cable fitted with a 4 mm eye lug, ground the digital relay chassis at the grounding screw shown below terminal block A.

## ! CAUTION

### HAZARD OF EQUIPMENT DAMAGE.

**If the grounding screw is lost, replace it with an M4 x 8 mm screw.  
Never use a grounding screw more than 8 mm long.**

Failure to observe this precaution can result in equipment damage.

### Control Power Wiring (cont.)

Both ac and dc models of the digital relay are available. The ac model of the digital relay supports 100–127 Vac power supplies; the dc model supports 48–125 Vdc power supplies. Figure 23 below illustrates control power wiring for both ac and dc models.

Connect control power to the two control power terminals and the grounding screw.

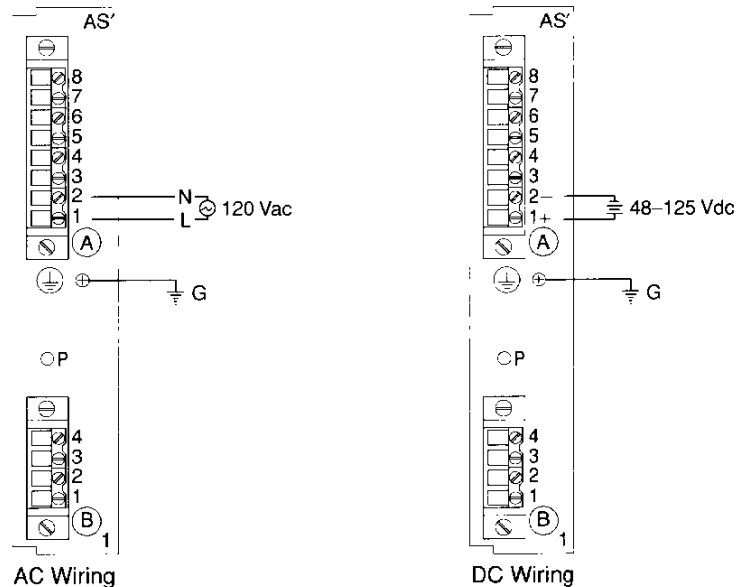

Figure 23: Control power wiring for digital relay ac and dc models

### Watchdog Relay Wiring

The digital relay continually performs a self-diagnostic check. If the unit detects an internal failure, the self-diagnostic LED on the front panel lights, indicating the digital relay is out of service. The protective relay contacts are then inhibited and a watchdog relay operates. The watchdog relay consists of two output relay contacts located on terminal block B, card 1.

For additional notification of an internal failure, connect the watchdog output relay contacts to an alarm (for example, a light or a bell), referring to figure 22 and the following contact specifications:

- output 4 (figure 22)—terminals 4 and 3 (normally open)
- output 5 (figure 22)—terminals 2 and 1 (normally closed)

**CARD 2 WIRING**

Figure 24 below illustrates wiring connections for card 2 of the digital relay. (In the example shown, the DIP switches are set for 5 A CTs and internal summation for ground fault.) Card 2 wiring requires that the CTs be wired to the CCA 650 phase current sensor module, which then plugs into the DB-9 male connector on terminal B, card 2. Phase current sensor module wiring is explained in more detail below.

Terminal block A on card 2 can be used to connect an optional CSH core balance CT to the digital relay. See **CSH Core Balance CTs**, page 74.

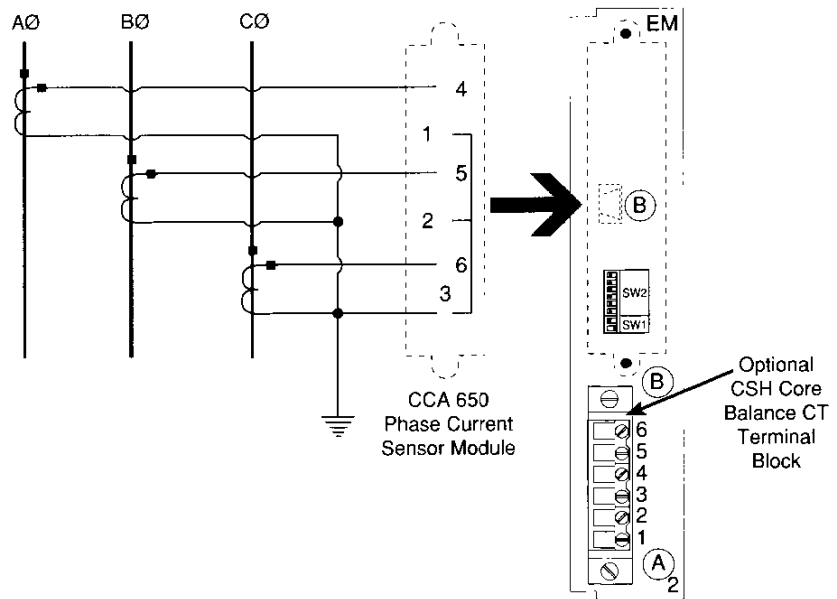

Figure 24: CCA 650 wiring example (for 5 A CTs with internal summation for ground fault)

**Wiring the CCA 650  
 Phase Current Sensor  
 Module**

**⚠ DANGER**

**HAZARD OF ELECTRIC SHOCK, BURN, OR EXPLOSION.**

- Only qualified electrical workers should install this equipment. Such work should be performed only after reading this entire set of instructions.
- Follow proper safety procedures regarding CT secondary wiring. *Never open-circuit the secondary of a CT.*

Failure to follow these precautions will result in electric shock, severe personal injury, or death!

## Wiring the CCA 650 Phase Current Sensor Module

### ! WARNING

#### HAZARD OF ELECTRIC SHOCK OR BURN.

Set DIP switches *before* attaching the CCA 650 phase current sensor module to the digital relay. Failure to correctly set DIP switches before attaching the CCA 650 can result in unintended operation of the trip output contacts. See Setting the DIP Switches, page 15.

Failure to follow this precaution could result in electric shock, severe personal injury, death, or equipment damage!

This phase current sensor module connects 1 A or 5 A current transformers.

The current transformer (1 A or 5 A) secondary leads connect to the CCA 650 phase current sensor module, which plugs into card 2 (figure 24). This connector contains three core balance CT primary crossing adapters to ensure impedance matching and isolation between the 1 A or 5 A circuits and the digital relay.

The phase current sensor module terminals accept AWG 14–AWG 10 wires fitted with eye lugs (user provides eye lugs). Each screw terminal can receive two 14 AWG wires or one 10 AWG wire. Terminals 1, 2, and 3 are connected by a removable jumper strap. Follow these steps to connect the current transformer secondary circuits to the phase current sensor module:

1. Carefully strip 0.4" to 0.45" (10–12 mm) of insulation from the end of each wire to be connected. Securely attach an eye lug to each wire, using a suitable crimping tool.

### ! WARNING

#### HAZARD OF ELECTRIC SHOCK OR BURN.

**Securely attach all eye lugs and other connectors.**

Failure to follow this precaution could result in electric shock, severe personal injury, death, or equipment damage!

2. Open the two side covers to gain access to the connection terminals. These covers can be easily removed to facilitate wiring, but *must* be replaced before connecting the CT to the digital relay.
3. Remove the jumper strap from terminals 1, 2, and 3 *only* if devices will be series-connected; see **Phase Current Sensor Module Wiring for Series-Connected Devices**, page 25, for more information. **If devices will not be series-connected, leave the jumper strap in place.**
4. Using the phase current sensor module, connect the phases as follows (figure 24 and 25):
  - Phase A: terminals 4 (+) and 1 (–).
  - Phase B: terminals 5 (+) and 2 (–).
  - Phase C: terminals 6 (+) and 3 (–).

**Wiring the Phase Current  
Sensor Module  
CCA 650 (cont.)**

Wire one terminal at a time, following these steps:

- a. Remove the terminal screw.
- b. Insert the screw through the appropriate wire's eye lug.
- c. Replace the screw in its terminal; tighten (figure 25) to 6–9 lb-in (0.68–1 N•m).

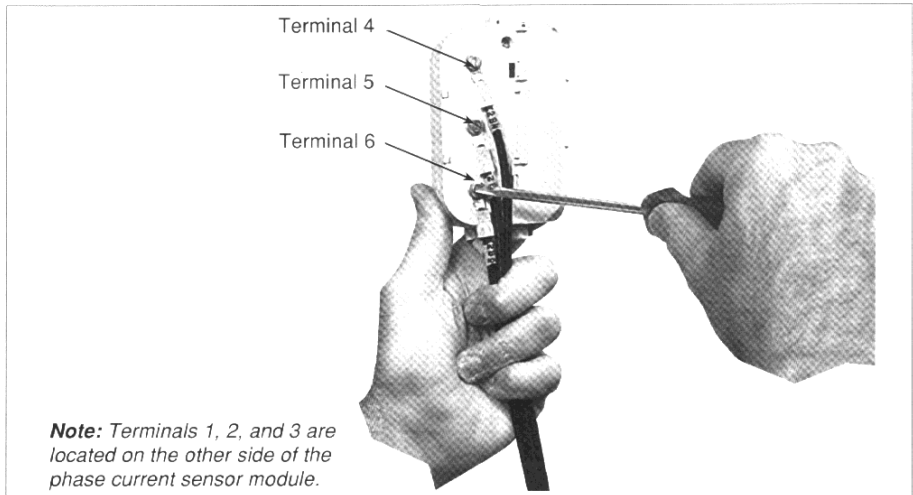

*Figure 25: Securing a phase wire eye lug to the phase current sensor module*

*Note: When fastening down the eye lugs, route the wires on the side opposite the terminal numbers so the wires do not obstruct the numbers.*

5. Close the side covers. The wires route out of the phase current sensor module through an opening in the bottom of each side cover.
6. Attach the DB-9 female connector of the phase current sensor module to the DB-9 male connector (2B) on the rear panel of the digital relay (figure 26).
7. Tighten the connector fastening screws on the digital relay rear panel (figure 27) to 6–9 lb-in (0.68–1 N•m).

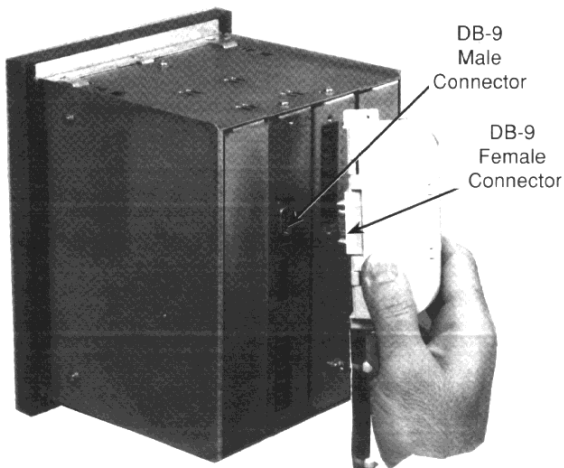

*Figure 26: Attaching phase current sensor module to digital relay*

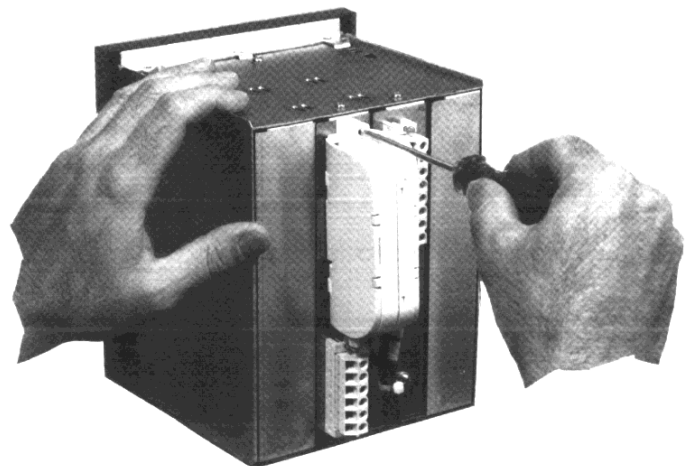

*Figure 27: Tightening phase current sensor module connector screws*

### Phase Current Sensor Module Wiring for Series-Connected Devices

When connecting devices in series, remove the jumper strap connecting terminals 1, 2, and 3 in the phase current sensor module. When the CT secondary leads are connected to another device in addition to the digital relay (for example, a circuit monitor), jumper the non-polarity side of the CTs together at the last device in the series. This is illustrated in figure 28 below.

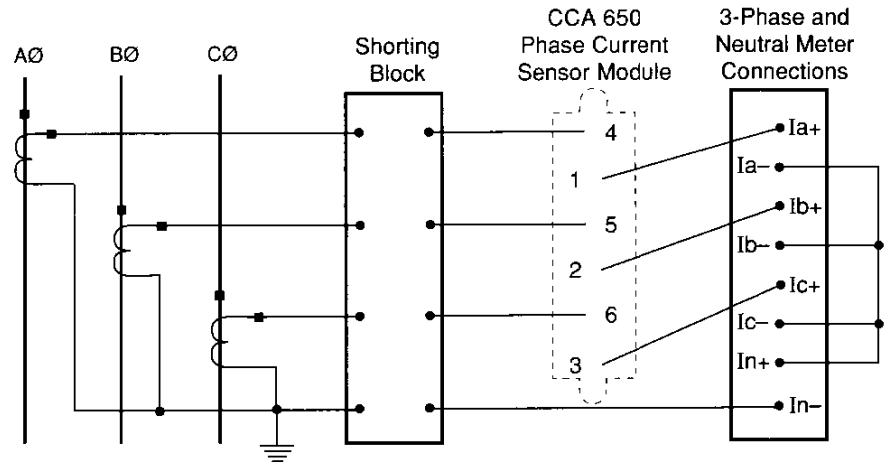

Figure 28: Series-connected wiring of the phase current sensor module

**CARD 3 WIRING  
 (COMMUNICATIONS)**

**Connecting to the  
 POWERLOGIC  
 Communications Link**

Digital relay models DR-LXS01 S0A TBN and DR-LXS01 S0A TEN include a communications card (card 3). This communications card (figure 29) supports:

- standard RS-485 POWERLOGIC communications
- one status input, typically for monitoring of circuit breaker position (open or closed)

As in all other POWERLOGIC devices, the digital relay with communications card uses an industry standard RS-485 (RS-422 compatible) electrical interface for data communications. Multiple digital relays, circuit monitors, and other POWERLOGIC devices can be daisy-chained together on a single POWERLOGIC communications link. See **Length of the Communications Link**, page 28, for distance limitations and different baud rates. Figure 30 shows multiple device types on a communications link.

The digital relay can be connected to a communications port on:

- a POWERLOGIC Network Interface Module (PNIM)
- a SY/MAX® PLC
- a personal computer equipped with a SY/LINK® PC interface board
- a serial communications port on a personal computer with an RS-485 converter

Digital relay models DR-LX S01 SOA TBN and DR-LX S01 SOA TEN include an RS-485 communications port for connection to a POWERLOGIC communications link. These digital relays use a removable, 8-position communications card connector, with the RS-485 connected at terminals 3A4-3A8 (figure 29).

As in other POWERLOGIC devices, the digital relay requires a communication cable containing two shielded, twisted pairs (Belden 8723 or AWG 22 equivalent). Daisy-chain communications cables from the digital relay's RS-485 communications terminals to the matching RS-485 communications terminals of the next device. That is, wire SHLD to SHLD, OUT- to OUT-, OUT+ to OUT+, IN- to IN-, and IN+ to IN+.

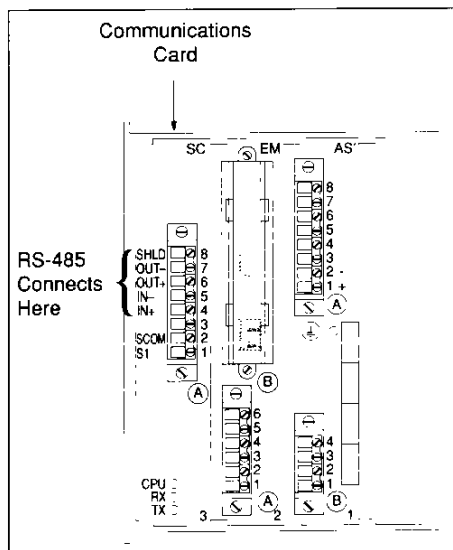

Figure 29: Communications card

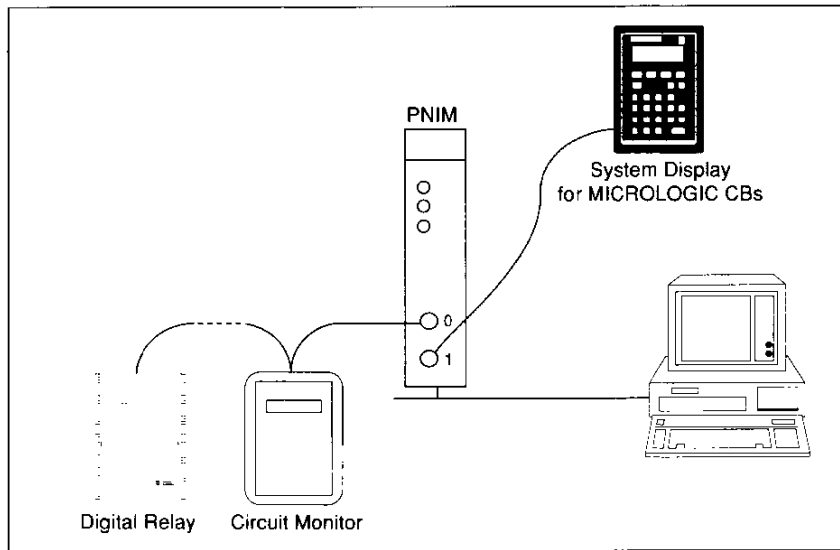

Figure 30: Multiple POWERLOGIC device types on a communications link

## Connecting to the POWERLOGIC Communications Link (cont.)

If the digital relay is the last device on the communications link, terminate it using a Multipoint Communications Terminator (MCT-485). See **Terminating the Communications Link**, page 30, for termination instructions. If the digital relay is the first device on the link, connect it to a communications port using a Multipoint Communications Adapter (MCA-485). See **Biasing the Communications Link**, page 28, for biasing instructions. To wire multiple devices together on the same communications daisy-chain, follow these steps:

1. Strip back the cable sheath 2" (51 mm) on both ends of the communications cable. Strip back the insulation for each wire; see the **Terminal Block Wiring Specifications** table, page 100, for the correct strip length.
2. Inspect the stripped ends for stray wire strands; if any are found, remove or reposition them to minimize the possibility of shorting across terminals.
3. Referring to table 4, page 29, connect the appropriate wire to the IN+ terminal on the digital relay's RS-485 8-position terminal block (figure 29, page 26). Connect the other end of the same wire to the IN+ terminal of the next device. Tighten both terminal screws; see the **Terminal Block Wiring Specifications** table, page 100, for the correct torque range.
4. Following the procedure in step 3, connect the IN- terminal on the digital relay to the IN- terminal on the next device, the OUT+ terminal on the digital relay to the OUT+ terminal on the next device, and so on. Tighten all terminal screws to the correct torque range.

For example, to wire a digital relay to a circuit monitor, connect the SHLD terminal on the digital relay to the SHLD terminal on the circuit monitor, connect the OUT- terminal on the digital relay to the OUT- terminal on the circuit monitor, connect the OUT+ terminal on the digital relay to the OUT+ terminal on the circuit monitor, and so on. Figure 31 illustrates this example.

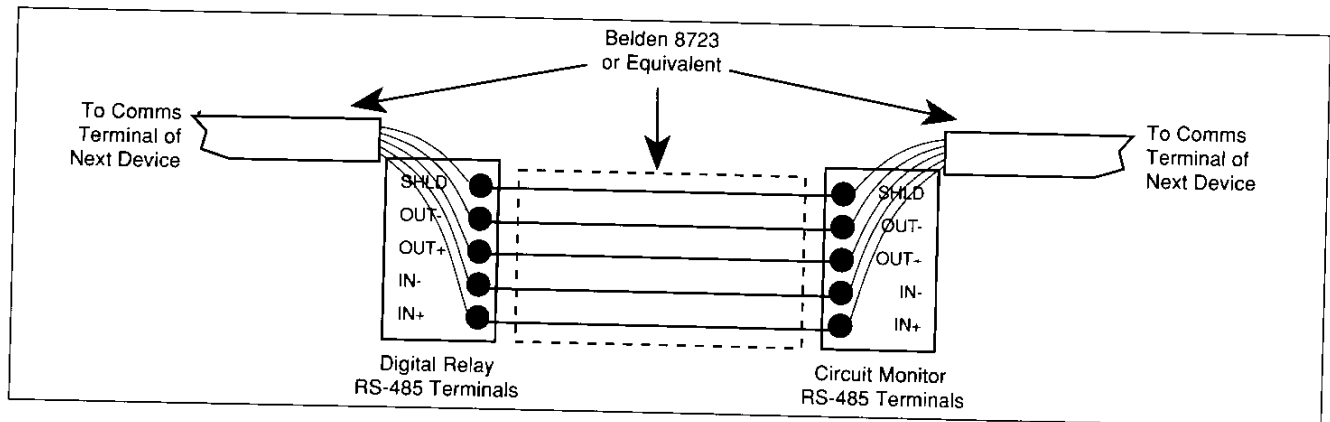

Figure 31: RS-485 communication wiring

*Note:* POWERLOGIC devices can be connected to other manufacturers' systems using available communications interfaces. Contact technical support for more information; see **Getting Technical Support**, page 67.

**Length of the Communications Link**

The length of the communications link cannot exceed 10,000 feet (3,048 m). This means that the total length of the communications cable from the PNIM, personal computer, or processor, to the last device in the daisy-chain cannot exceed 10,000 feet (3,048 m). When 17 or more devices are on a communication link, the maximum distance may be shorter, depending on the baud rate. Table 3 shows the maximum distances at different baud rates.

**Table 3**  
**Maximum Distances of Communications Link at Different Baud Rates**

Baud Rate	Maximum Distance—Ft. (m)	
	1-16 Devices	17-32 Devices
1200	10,000 (3,048)	10,000 (3,048)
2400	10,000 (3,048)	5,000 (1,524)
4800	10,000 (3,048)	5,000 (1,524)
9600	10,000 (3,048)	4,000 (1,219)
19200	10,000 (3,048)	2,500 (762)

**Biasing the Communications Link**

To ensure reliable communications, you must bias the POWERLOGIC communications link. Use a Multipoint Communications Adapter (MCA-485) biasing device. Place the adapter between the first device on the link and the communications port of the PNIM or SY/LINK card. Figure 32 illustrates installation of the adapter when the first device on the link is a digital relay.

To connect the digital relay as the first device on the POWERLOGIC communications link, the following items are necessary:

- One POWERLOGIC Multipoint Communications Adapter MCA-485 (Class 3090). (This is not included with the digital relay; it must be purchased separately.)
- One POWERLOGIC cable CAB-107 or equivalent (Class 3090). (This is not included with the digital relay; it must be purchased separately.)
- A 5-position terminal block—1 provided with each communicating digital relay (model numbers DR-LXS01 S0A TBN and DR-LXS01 S0A TEN).
- Belden 8723 or equivalent cable. (This is not included with the digital relay; it must be purchased separately.)

Figure 32 illustrates the wiring connections. Refer to this figure when completing the following steps.

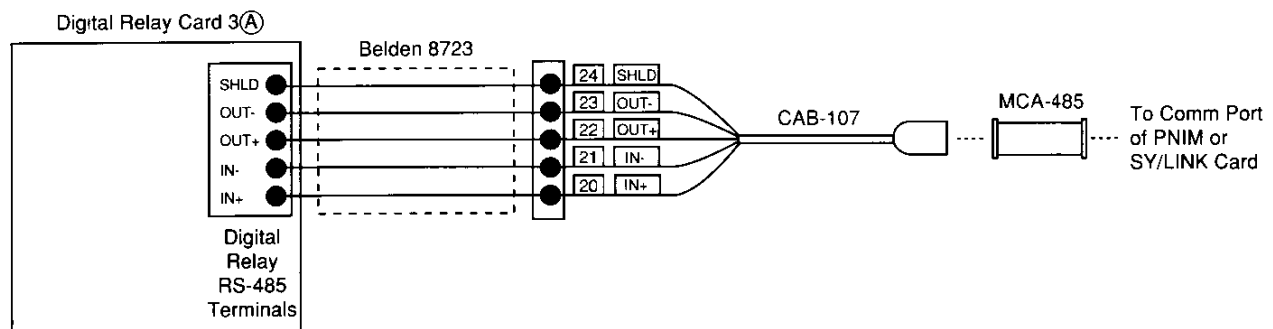

Figure 32: Connecting the digital relay as the first device on a POWERLOGIC communications link

## Biassing the Communications Link (cont.)

To connect the digital relay as the first device on the POWERLOGIC communications link, complete the following steps:

1. Install the terminal block in a convenient location.

*Note: The CAB-107 cable is 10 feet (3 m) long. If the terminal block must be located farther than ten feet from the PNIM, PC, or system display, a custom cable must be built. To build a custom cable, use Belden 8723 cable and a male DB-9 connector. See the CAB-107 pinout, page 73.*

2. Plug the male end of the MCA-485 into the communications port of the PNIM, SY/LINK board, or other host device.

*Note: When connecting to a PNIM, connect the digital relay to the top RS-422 port, labeled port 0. This port must be configured for POWERLOGIC mode.*

3. Carefully mark the flying leads on the CAB-107 as indicated in table 4 below. For example, mark the green wire, labeled 20, as "IN+"; mark the white wire, labeled 21, as "IN-"; and so on.

**Table 4**  
Labeling the CAB-107 Leads

Existing Label	Wire Color	Mark As
20	Green	IN+
21	White	IN-
22	Red	OUT+
23	Black	OUT-
24	Silver	SHLD

4. Attach the male DB-9 connector on the CAB-107 to the MCA-485.
5. Connect the CAB-107 spade connectors to the 5-position screw terminal block. Tighten all terminal screws to 6–9 lb-in (0.68–1 N•m).
6. Cut a length of Belden 8723 (or equivalent) cable that is long enough to reach from the terminal block to the digital relay. Strip back the cable sheath 2" (51 mm) from both ends.
7. On one end of the Belden 8723 (or equivalent) cable, carefully strip .25" (6 mm) from the end of each wire to be connected. Using a suitable crimping tool, securely attach a forked terminal (spade connector) to each wire.
8. Connect the cable end with attached spade connectors to the 5-position screw terminal block. Tighten all screws to 6–9 (0.68–1 N•m) to the terminal block. Tighten all terminal screws to 6–9 lb-in (0.68–1 N•m).
9. On the other cable end, carefully strip .8"–.9" (20–23 mm) of insulation from the end of each wire to be connected. On each wire, fold the tip of the *stripped* wire back to the strip mark, doubling the thickness of the stripped wire. Each wire should now have .4"–.45" [10–11 mm] of *doubled, stripped* wire.
10. Connect the Belden 8723 (or equivalent) cable to the removable 8-position terminal block (labeled *RS-485 Comms*) on the digital relay. Be sure to connect the terminal accepting the IN- wire on the CAB-107 to the IN-terminal on the digital relay, the terminal accepting the IN+ wire on the CAB-107 to the IN+ terminal on the digital relay, and so on. Tighten all terminal screws to 3–5 lb in (0.34–0.56 N•m).

*Note: An alternative to using a terminal block and a CAB-107 is to build a custom cable using Belden 8723 cable (or equivalent) and a male DB-9 connector. When building the cable, follow the CAB-107 pinout shown on page 73.*

## Terminating the Communications Link

To ensure reliable communications, terminate the last device on a POWERLOGIC communications link. Figure 33 illustrates terminator placement when the final device on the link is a digital relay. If the last device is not a digital relay, refer to the last device's instruction bulletin for termination instructions.

*Note: If a communications link contains only a single device, it must be terminated. If a link contains multiple devices, as in figure 33, only the last device must be terminated.*

To connect the digital relay as the last device on the POWERLOGIC communications link, the following items are necessary:

- One POWERLOGIC RS-485 Multipoint Communications Terminator (MCT-485, Class 3090). (This is not included with the digital relay; it must be purchased separately.)
- A 5-position terminal block—1 provided with each digital relay with optional communications card.
- Belden 8723 or equivalent cable. (This is not included with the digital relay; it must be purchased separately.)

Figure 33 illustrates proper termination. Refer to this figure when completing the steps listed below.

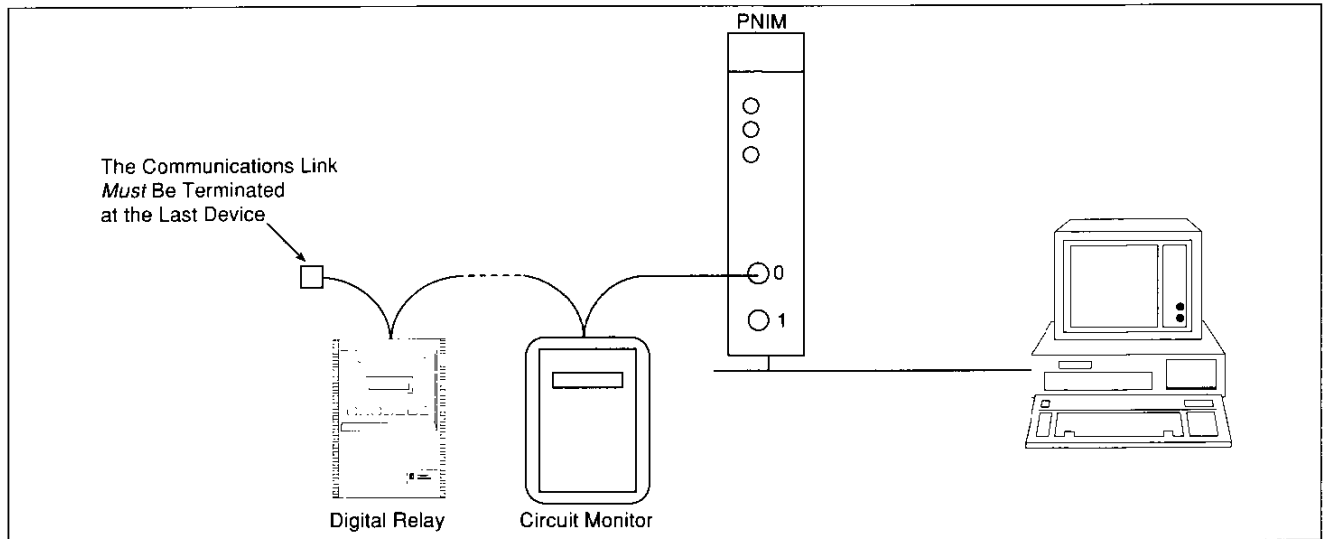

Figure 33: RS-485 terminator placement

To connect the digital relay as the last device on the POWERLOGIC communications link (figure 34), complete the following steps:

1. Install the terminal block in a convenient location.
2. Cut a length of cable long enough to reach from the digital relay to the terminal block.
3. Strip back the cable sheath 2" (51 mm) from both cable ends. Strip back the insulation for each wire; see the **Terminal Block Wiring Specifications** table, page 100, for the correct strip length.
4. Connect one end of the cable to the digital relay IN+, IN-, OUT+, OUT-, and SHLD terminals. Tighten all terminal screws; see the **Terminal Block Wiring Specifications** table, page 100, for the correct torque range.

**Terminating the Communications Link (cont.)**

5. Trace the wire color codes and mark the cable wires at the other end of the cable as IN+, IN-, OUT+, OUT-, and SHLD, corresponding to the COMMS terminals on the digital relay.
6. Connect the marked wires to the terminal block. Tighten all terminal screws to 6–9 lb-in (0.68–1 N•m).
7. Connect the four spade connectors on the multipoint communications terminator to the OUT-, OUT+, IN-, and IN+ positions on the terminal block. Tighten all terminal screws to 6–9 lb-in (0.68–1 N•m).

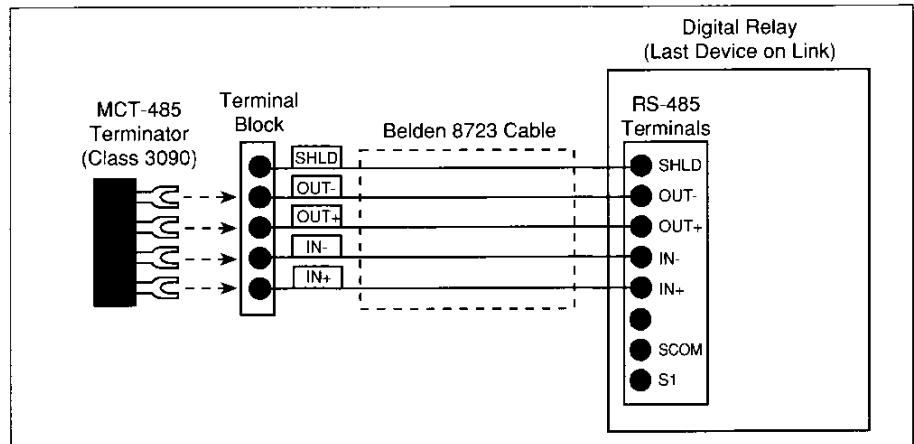

Figure 34: Connecting the RS-485 terminator to a digital relay

**STATUS INPUT CONNECTIONS**

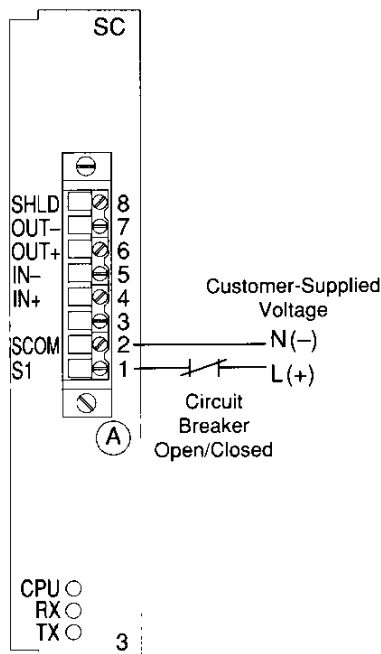

Figure 35: Typical status input connections

**! WARNING**

**HAZARD OF ELECTRIC SHOCK OR BURN.**

**Disconnect all power sources before making status input connections.**

Failure to follow this precaution could result in electric shock, severe personal injury, death, or equipment damage!

The digital relay with optional communications card offers one status input. The input can be used to sense the state of external contacts, such as those of a circuit breaker. Figure 35 shows a typical input connection. Follow these steps to wire the status input connections:

1. Use only AWG 14–22 stranded wire.
2. Strip back the insulation for each wire; see the **Terminal Block Wiring Specifications** table, page 100, for the correct strip length.
3. Connect the wires as shown in figure 35. Tighten the terminal screws; see the **Terminal Block Wiring Specifications** table, page 100, for the correct torque range.



## CHAPTER 7—FRONT PANEL OPERATION

### FRONT PANEL

The front panel (figure 36) of the digital relay is equipped with:

- a 7-button keyboard which is used to:
  - cycle through the digital relay's display menus
  - configure the digital relay's protection settings
- a 16-character liquid crystal display which displays:
  - phase ammeter readings
  - phase demand ammeter readings
  - phase/ground amperes at time of last trip
  - all setup values
  - messages
- three indicators, which display digital relay status as follows:
  - green *on* LED: control power is on
  - red self-diagnostic LED (above wrench icon): digital relay out of service; maintenance required
  - red *trip* indicator: relay has operated and has not been reset

### ENERGIZING

When initially energized or re-energized, the digital relay automatically restarts in the following sequence:

- the green *on* LED and red self-diagnostic LED light
- the red self-diagnostic LED goes out
- the watchdog relay contacts reset
- the digital relay displays the version name followed by the version letter, for example, "DR LXS01 K"

*Note:* To test the indicators and the display, press simultaneously on the meters and device buttons. All indicators and LCDs will activate.

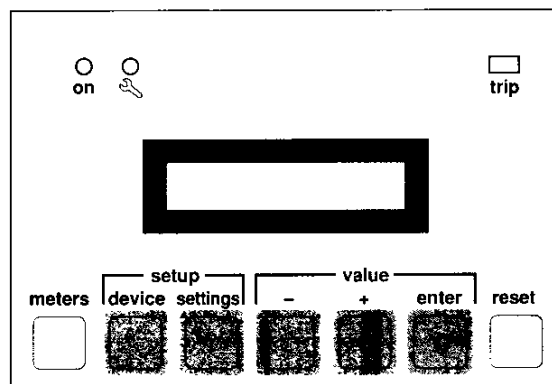

Figure 36: Front panel

## MODES

The digital relay has two basic modes: Standard and Setup. An overview of these modes follows.

- Setup Mode—The digital relay's settings are defined and modified in the Setup mode. While in this mode, you can:
  - scroll through all display pages
  - use the value buttons (–, +, and *enter*) to define or modify the relay's configuration
- Standard Mode—This is the digital relay's basic operating mode. While in this mode, you can:
  - scroll through all display pages
  - use the *meter*, *device*, and *settings* buttons to display metered values and settings (the value buttons are inoperable in the Standard mode)

*Note: Settings cannot be altered in the Standard mode. Settings must be defined or changed in the Setup mode. See Setting Parameters, page 35.*

After **Settings And Metered Values**, which explains how to access the settings and metered values available on the digital relay, the Setup and Standard modes are detailed more fully.

## SETTINGS AND METERED VALUES

The digital relay settings and metered values can be viewed by pressing (individually) the *meters*, *device*, and *settings* buttons. The readings and settings are arranged in loops, as shown in figure 37. For definitions of the readings and settings shown, see **Glossary**, page 71.

Data is divided by category into three loops, linked to the three function buttons. The buttons, and related loops, are defined as follows:

- *meters* button: metered values
- *device* button: general device settings
- *settings* button: protection settings

Each loop is divided into pages. Each page has a title, indicated by an asterisk before and after (e.g., *"\* Ammeter \**"). See figure 37.

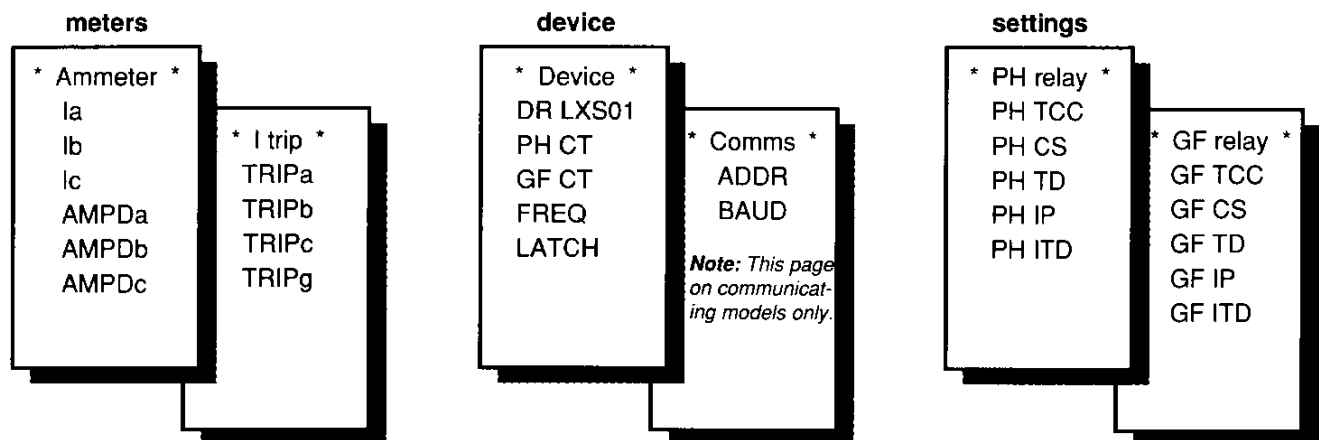

Figure 37: Pages available on digital relay

**SETTINGS AND METERED VALUES (cont.)**

To move through a loop, press the corresponding *meters*, *device*, or *settings* button as follows:

- Press the button for more than one second to move from page to page.
- Once on a page, a momentary button press will scroll from one setting or metered value to another.

Figure 38 illustrates how to navigate the pages.

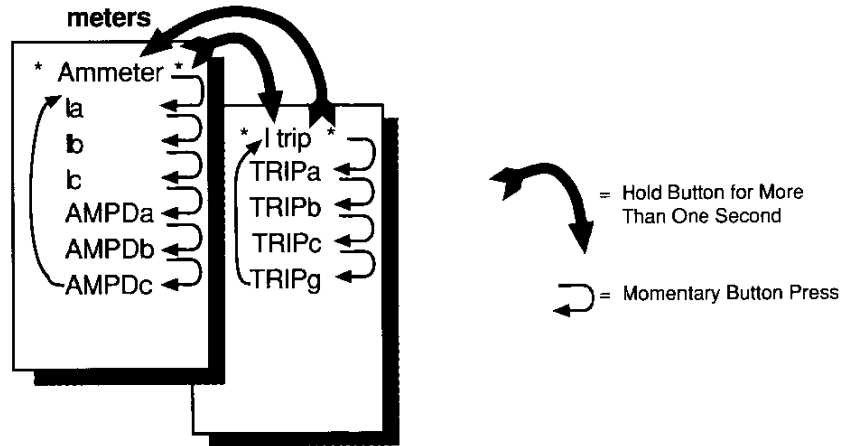

Figure 38: Navigating digital relay meters pages

**SETUP MODE**

This section tells how to access the Setup mode, and set or adjust parameters.

**Setting Parameters**

Follow these steps to switch to the Setup mode and set parameters:

1. Locate the parameter setup mode access hole marked *P* on the rear of the digital relay. The access hole is located on the lower portion of card 1. Insert the tip of a pen into the access hole and press for one second to switch to the Setup mode (figure 39). The letter "P" displays at the extreme right of the LCD display (figure 41), indicating that the digital relay is in the (parameter) Setup mode.

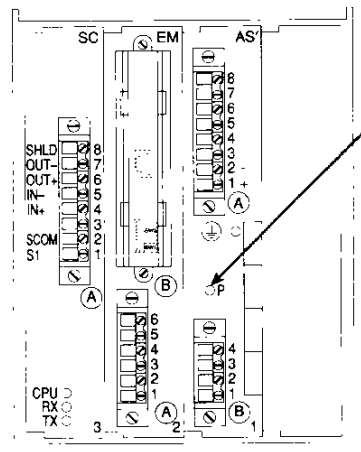

Figure 39: Location of parameter setup mode access hole (marked P)

**Setting Parameters (cont.)**

2. To define parameters for the *device* page(s):
  - a. Press and hold the *device* button for one second until **"\* Device \*"** displays (figure 40).
  - b. Briefly press the *device* button again. The model type displays.
  - c. Briefly press the *device* button again. The PH CT setting displays (figure 41).
3. Use the *value-* and *value+* buttons to scroll through the possible settings. The new value flashes on the display until it is stored (figure 42).

*Note: Possible settings are presented in a loop. Regardless of whether you are pressing the value- or value+ button, the display scrolls through one unit of measure (example: kA) and then through any other unit of measure available.*

4. Press the *enter* button to store the new setting. The displayed setting stops flashing (figure 43) and goes into effect immediately.

**! WARNING**

**HAZARD OF ELECTRIC SHOCK OR BURN.**

**A new setting is not applied to the digital relay configuration until you press the *enter* button to store the new setting. Failure to do so could result in unintended operation of the trip output contacts. If the "CHECK SETTINGS" message appears when you press *enter*, the new setting conflicts with other settings; see Conflicting Settings, page 38.**

Failure to follow this precaution could result in electric shock, severe personal injury, death, or equipment damage!

5. Repeat steps 2c–4 to set parameters for other *device* settings (refer to figure 37, page 34, for page menu structure). *Note: When repeating step 2c, a setting other than PH CT displays.*
6. For communicating versions of the digital relay, press and hold the *device* button for one second until **"\* Comms \*"** is displayed. Then follow steps 2c–4 to set the address and then the baud rate parameters. *Note: When repeating step 2c, a setting other than PH CT displays.*
7. To define parameters for the *settings* pages:
  - a. Press and hold the *settings* button for one second until **"\* PH relay \*"** displays.
  - b. Briefly press the *settings* button again. The PH TCC setting displays.

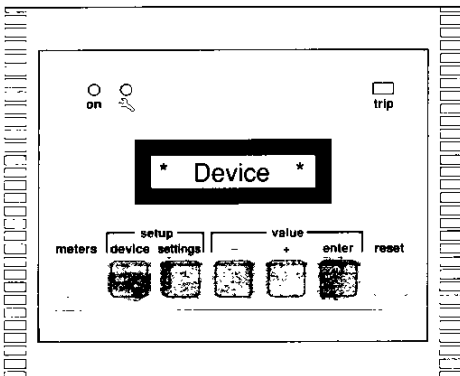

Figure 40: **"\* Device \*"** displayed



Figure 41: Original PH CT setting



Figure 42: New setting flashes



Figure 43: New setting stored; stops flashing

**Setting Parameters (cont.)**

8. Use the *value-* and *value+* buttons to scroll through the possible settings. The new value flashes on the display until it is stored.
9. Press the *enter* button to select the new setting. The displayed setting stops flashing and goes into effect immediately.

**! WARNING****HAZARD OF ELECTRIC SHOCK OR BURN.**

**A new setting is not applied to the digital relay configuration until you press the *enter* button to store the new setting. Failure to do so could result in unintended operation of the trip output contacts. If the “CHECK SETTINGS” message appears when you press *enter*, the new setting conflicts with other settings; see Conflicting Settings, page 38.**

Failure to follow this precaution could result in electric shock, severe personal injury, death, or equipment damage!

10. Repeat steps 7b–9 to set parameters for other phase relay settings (refer to figure 37, page 34, for page menu structure). *Note: When repeating step 7, a setting other than PH TCC displays.*
11. To define parameters for the ground fault relay:
  - a. Press and hold the *settings* button for one second until “\* GF relay \*” displays.
  - b. Briefly press the *settings* button again. The GF TCC setting displays.
12. Use the *value-* and *value+* buttons to scroll through the possible settings. The new value flashes on the display until it is stored.
13. Press the *enter* button to select the new setting. The displayed setting stops flashing and goes into effect immediately.
14. Repeat steps 11b–13 to set parameters for other ground fault relay settings (refer to figure 37, page 34, for page menu structure). *Note: When repeating step 11b, a setting other than GF TCC is displayed.*

**! WARNING****HAZARD OF ELECTRIC SHOCK OR BURN.**

**A new setting is not applied to the digital relay configuration until you press the *enter* button to store the new setting. Failure to do so could result in unintended operation of the trip output contacts. If the “CHECK SETTINGS” message appears when you press *enter*, the new setting conflicts with other settings; see Conflicting Settings, page 38.**

Failure to follow this precaution could result in electric shock, severe personal injury, death, or equipment damage!

15. One minute after the last button press in the Setup mode, the digital relay automatically reverts to the Standard mode. You can manually exit the Setup mode by pressing the button in the parameter setup mode access hole.

## Conflicting Settings

Some settings are linked to other settings. For example:

- The values of PH CS and PH IP depend on PH CT; those of GF CS and GF IP depend on GF CT.
- The setting ranges for PH CS, GF CS, PH TD, and GF TD depend on PH TCC and GF TCC.

Changing the value of PH CT, GF CT, PH TCC, or GF TCC can cause automatic modification of linked settings. When this occurs, the digital relay displays the "CHECK SETTINGS" message (figure 44).

Any settings which are automatically modified (because another setting is changed) will flash. Scroll through all settings. Each time you see a setting which is flashing because it was automatically modified, press *enter* to verify the change.

Once all the flashing settings are checked and verified, the "CHECK SETTINGS" message disappears.



Figure 44: "CHECK SETTINGS" message

## STANDARD MODE

This is the digital relay's basic operating mode. Use the *meters*, *device*, and *settings* buttons to display metered values and settings. The capabilities of each button are described below.

*Note: The value buttons are inoperable in the Standard mode.*

### Meters Button

Press the *meters* button (figure 45) to display the values measured by the digital relay. Measured values are listed below.

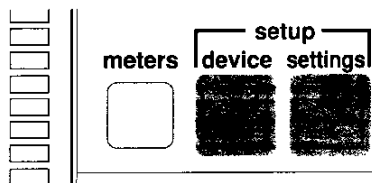

Figure 45: meters button location

- **"\* Ammeter \*"** page:
  - "Ia": phase A current; see figure 46 for an example
  - "Ib": phase B current
  - "Ic": phase C current
  - "AMPDa": maximum phase A current demand
  - "AMPDb": maximum phase B current demand
  - "AMPDc": maximum phase C current demand
- **"\* I trip \*"** page:
  - "TRIPa": phase A trip current
  - "TRIPb": phase B trip current; see figure 47 for an example
  - "TRIPc": phase C trip current
  - "TRIPg": ground fault trip current; see figure 48 for an example



Figure 46: Phase A current measurement

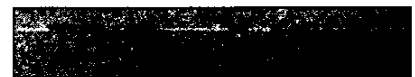

Figure 47: Phase B trip current measurement

**Meters Button (cont.)**

*Note:* AMPDa, AMPDb, and AMPDc measure the highest historical block demand calculation for the respective phases (since reset). TRIPa, TRIPb, and TRIPc report the value of current for the respective phases at the last trip.

If the phase fault current exceeds 24 x PH CT, the digital relay can no longer distinguish between the three phase currents. Therefore, TRIPa, TRIPb, and TRIPc display a “greater than” symbol (figure 49), indicating the phase fault current has exceeded the maximum trip current measurement.



Figure 48: Ground fault trip current measurement



Figure 49: Maximum trip current measurement

**Device Button**

Press the *device* button (figure 50) to display the digital relay general settings related to the equipment to which it is connected. Once you’ve commissioned the digital relay, these setup parameters are not likely to change.

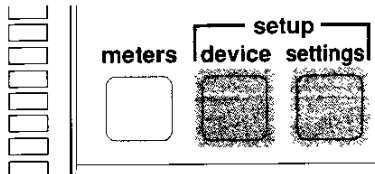

Figure 50: device button location

Parameters are listed below.

- “\* Device \*” page:
  - “PH CT”: CT primary current rating
  - “GF CT”: CSH core balance CT rating or primary rated current of standard zero sequence CT
  - “FREQ”: rated network frequency
  - “LATCH”: output contact latching
- “\* Comms \*” page:
  - “ADDR”: address (applies only to models with communicating option)
  - “BAUD”: baud rate (applies only to models with communicating option)

**Settings Button**

Press the *settings* button (figure 51) to display the protective relay parameter settings. Table 5 below shows the parameter for each display abbreviation.

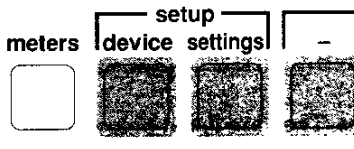

Figure 51: settings button location

Table 5: Display Parameters

Display Abbreviation	Parameter
PH TCC	Phase time current curve
PH CS	Phase current setting
PH TD	Phase time delay
PH IP	Phase instantaneous pickup
PH ITD	Phase instantaneous time delay
GF TCC	Ground fault time current curve
GF CS	Ground fault current setting
GF TD	Ground fault time delay
GF IP	Ground fault instantaneous pickup
GF ITD	Ground fault instantaneous time delay

## Settings Button (cont.)

Parameters are listed below.

- “\* PH relay \*” page:
  - “PH TCC”: selected curve for the phase overcurrent function
  - “PH CS”: current setting for the phase overcurrent function
  - “PH TD”: time delay for the phase overcurrent function
  - “PH IP”: phase instantaneous pickup
  - “PH ITD”: time delay for the phase instantaneous function
- “\* GF relay \*” page:
  - “GF TCC”: selected curve for the ground fault overcurrent protection
  - “GF CS”: current setting for the ground fault overcurrent protection
  - “GF TD”: time delay for the ground fault overcurrent protection
  - “GF IP”: ground fault instantaneous pickup
  - “GF ITD”: time delay for the ground fault instantaneous pickup

## Reset Button

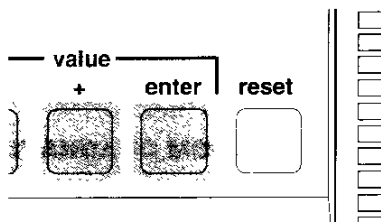

Figure 52: reset button location

Acknowledge the protective systems after tripping by pressing the *reset* button (figure 52).

Acknowledgment results in:

- extinction of the red *trip* indicator
- clearing of the trip message from the display
- release of the protection output relay contacts, if they are latched

*Note:* Pressing the *reset* button has no effect if a protective system still detects a fault.

The *reset* button is also used to reset the maximum block demand ammeters to zero. Follow these steps to reset the maximum demand ammeters:

1. Display one of the three maximum block demand ammeters (“AMPDa,” “AMPDb,” or “AMPDc,” located on meters page).
2. Press the *reset* button.

The three maximum demand ammeters reset to zero.

## MESSAGES

The digital relay displays three types of messages. They are listed below in order of priority:

- trip message
- alarm message
- “CHECK SETTINGS” message

A discussion of the different messages follows, beginning with the lowest priority message and proceeding to the highest priority message.

### Check Settings Message

“CHECK SETTINGS” displays when specific settings problems occur (see **Setting Parameters**, page 35). Certain settings are linked to other settings. If one of these settings is changed, the digital relay automatically changes the linked settings. A “CHECK SETTINGS” message results. See **Conflicting Settings**, page 38.

### Alarm Message

Alarm messages display whenever a pickup setting is exceeded. When more than one type of fault occurs at almost the same time, only the last fault to occur triggers an alarm message. Table 6 below shows alarm messages and their meanings.

**Table 6: Alarm Messages**

Alarm Message	Meaning
“PHASE FAULT”	Phase current is above the overcurrent pickup
“GND FAULT”	Ground fault current is above the overcurrent pickup

### Trip Message

A blinking trip message displays whenever a protective relay operates. The message indicates the fault that caused the operation. The red trip indicator LED also flashes. The trip message is latched; it remains on the display until the relay is cleared by pressing the *reset* button. When the *reset* button is pressed, the *trip* message disappears and the trip indicator LED goes out. If control power fails, the message is saved.

For example, if any phase current exceeds the current setting, the “PHASE FAULT” alarm message displays. This message displays continuously until one of two conditions is satisfied:

1. The phase current drops below the current setting; when this occurs, the alarm message disappears.
2. If the phase current remains above the current setting long enough to cause a trip, both the “PHASE FAULT” message and the *trip* indicator flash. Both continue to flash until the fault is cleared and the *reset* button is pressed.

Table 7 shows trip messages and their meanings.

**Table 7: Trip Messages**

Flashing Trip Message	Meaning
“PHASE FAULT”	Phase protection tripped
“GND FAULT”	Ground fault protection tripped

### Message Priority

Message priority management is as follows:

- Higher priority messages replace lower priority messages on the display. For example, if the “CHECK SETTINGS” message is displayed and an alarm occurs, the alarm message overrides the “CHECK SETTINGS” message and is displayed instead. If the condition which caused the alarm continues, a trip relay operates and the alarm message flashes, indicating it has become a higher-priority trip message. The *trip* indicator also activates.
- Press any button to return the display to normal readings for 20 seconds.



## CHAPTER 8—COMMISSIONING

### INTRODUCTION

Commissioning the digital relay includes dielectric testing and testing the following operations with the digital relay energized:

- parameter setting
- metering
- protection

Before commissioning the digital relay, ensure that it is correctly installed (wiring, connections, DIP switch setting, etc.). For further information, refer to the **Installation, Wiring, and Setting the DIP Switches** sections.

### ! WARNING

#### HAZARD OF ELECTRIC SHOCK OR BURN.

**This section contains procedures for setting up and testing the protective relay. Perform all procedures before the protected circuit is energized.**

Failure to follow this precaution could result in electric shock, severe personal injury, death, or equipment damage!

### DIELECTRIC TESTING

Due to the presence of capacitance between some circuits and the digital relay frame, dc voltage is recommended for dielectric testing.

The digital relay dielectric withstand capacity is 2.0 kV dc for 1 minute.

Galvanically independent circuits between which dielectric stress can be applied are listed below. Each bulleted item represents a galvanically independent circuit. You can apply dielectric stress between any two terminals listed below which are *not on the same circuit* (bulleted item).

### ! CAUTION

#### HAZARD OF EQUIPMENT DAMAGE.

**Do not apply dielectric stress between any terminals that are part of the same galvanically independent circuit. For example, on the last bulleted item in the following list, *never* apply dielectric stress between terminals 2A4, 2A1, 2A2, or 2A3.**

Failure to follow this precaution could result in equipment damage.

- control power supply (terminals 1A1, 1A2)
- current input Ia (phase current sensor module terminals 1 and 4)
- current input Ib (phase current sensor module terminals 2 and 5)
- current input Ic (phase current sensor module terminals 3 and 6)

**DIELECTRIC TESTING  
(cont.)**

- output 1 (terminals 1A7, 1A8)
- output 2 (terminals 1A5, 1A6)
- output 3 (terminals 1A3, 1A4)
- output 4 (terminals 1B3, 1B4)
- output 5 (terminals 1B1, 1B2)
- chassis ground (2A4) and current input Ig (terminals 2A1, 2A2, 2A3)

**ENERGIZING**

Follow these steps to energize the digital relay:

1. Ensure that the control power supply voltage is within the admissible range for the digital relay, that is:
  - 48 to 125 V  $\pm 20\%$  for models DR-LXS01 X0A TBN and DR-LXS01 S0A TBN
  - or
  - 100 to 127 V  $+10\%$   $-20\%$  for models DR-LXS01 X0A TEN and DR-LXS01 S0A TEN
2. Energize the unit. The *on* indicator lights up. The self-diagnostic internal fault indicator lights up for about 2 seconds during the start-up (initialization) phase.

If the *on* indicator does not light up:

- check the control power supply cabling
- check the supply voltage at the digital relay inputs (terminals 1A1 and 1A2)

If these checks indicate nothing abnormal, the digital relay is out of service. Also, if the internal fault indicator remains steadily lit, the digital relay is out of service.

**GENERAL DEVICE SETUP**

Before proceeding with the digital relay testing, you must select general device setup parameters. These parameters (accessed by pressing the device setup key) reflect the digital relay installation characteristics, such as CT ratios and system frequency. These parameters are generally set up once and not changed. Follow the instructions below to set specific parameters.

Activate the Setup mode and select the device settings by pressing the *device* button (refer to **Setup Mode**, page 35).

**PH CT Setup**

Set "PH CT" to equal the CT primary rated current.

*Note: CT secondary rated current is selected by SW2 DIP switches; see page 16.*

**GF CT Setup**

The default ground fault measurement technique uses internal summation of the phase currents. For normal operation in this mode, select "GF CT=PH CT." This setting causes the value of "GF CT" to always match that of "PH CT."

If using the optional CSH core balance CT, see **CSH Core Balance CTs**, page 74.

**FREQ Setup**

Set "FREQ" to the rated frequency of the network being protected (50 Hz or 60 Hz).

**LATCH Setup**

The "LATCH" setting determines whether or not the output contacts should be latched after tripping.

 **LATCH Setup (cont.)**

Set to "YES" for latching and "NO" for no latching. If "NO" is selected, the digital relay will repeatedly try to reset the output contacts. If "YES" is selected, the digital relay will not attempt to reset until the *reset* button is pressed.

*Note: The trip indicator and trip message on the front panel are always latched. The yellow reset button must be pressed to clear the trip message, regardless of "LATCH" setting.*

**Setting the Device Address**

Device address applies only to communicating models. Choose the \* Comms \* page by pressing the *device* button.

Each POWERLOGIC device on a communications link must have a unique device address. (The term communications link refers to 1–32 POWERLOGIC-compatible devices daisy-chained to a single communications port.) The allowable range of addresses is 1 to 198. The factory default address is 1.

*Note: By networking groups of devices, POWERLOGIC systems can support a virtually unlimited number of devices.*

When addressing POWERLOGIC devices, each device on a single communications link—including the PNIM or SY/LINK® card—*must* be assigned a unique address.

 **Setting the Baud Rate**

Baud rate applies only to communicating models. Choose the \* Comms \* page by pressing the *device* button. Set the digital relay baud rate to match the baud rate of all other devices on the communications link. The available baud rates are 1200, 2400, 4800, 9600, and 19200. The factory default is 9600 bps.

The maximum baud rate is limited by the number of devices and total length of the communications link. See **table 3**, page 28, for distance restrictions at varying baud rates.

**TEST METHODS**

Methods of testing the digital relay and its components are detailed below.

**Checking Phase Current Input Wiring and CT Ratio**

Before proceeding with measurement and protection testing described in this section, sensor connections must be validated by primary current injection. Follow these steps:

1. Inject into the primary winding of each CT a current greater than 5% of the rated current "PH CT".
2. Check the CT ratios and the phase sequence by reading the current shown on the digital relay display (*meters* button).

After validating the sensor connections by primary current injection, test the device settings using either primary or secondary current injection; descriptions of both methods follow.

 **CT Primary Current Injection**

Sensor primary current injection (CT or core balance CT) offers the advantage of testing the entire chain: sensor, wiring, and relays. The method does, however, have the drawback of requiring very heavy current when the sensor primary rated current is high.

The sensor and its wiring can be tested via this method using only the lowest levels of current read by the digital relay (5% of "PH CT").

### CT Secondary Current Injection

This method is used to check the digital relay phase current inputs. See figure 53. When the digital relay is equipped with a test block, testing can be done without disconnecting the cables from the CTs.

## ! WARNING

### HAZARD OF ELECTRIC SHOCK OR BURN.

**Do not inject current into the DB-9 male connector (B on card 2) of the digital relay. Inject *only* across the terminals of phase current sensor module CCA 650.**

Failure to follow this precaution could result in electric shock, severe personal injury, death, or equipment damage!

Limit the duration of the injection to avoid damaging the digital relay inputs. The digital relay can withstand 3 times the "PH CT" setting injected continuously, and 24 times the "PH CT" for 3 seconds. The ratio between the injected current and the current measured by the digital relay is equal to the CT ratio. For example, with a 150/5 CT, for the digital relay to measure 180 A, it is necessary to inject 6 A ( $6 = 180 \times 5/150$ ).

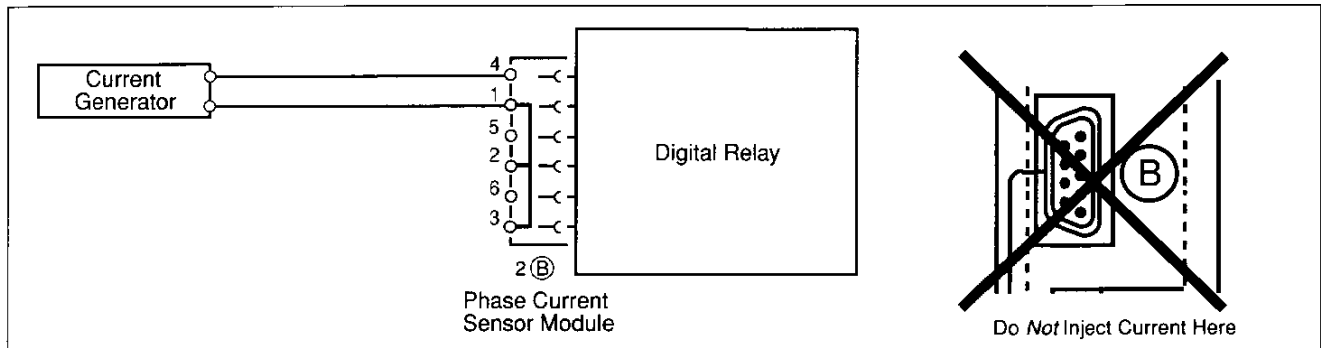

Figure 53: Example of phase A injection

### Zero Sequence Current Injection

To measure ground fault current by summation of phase currents, current is injected into one of the three phase inputs. In this case, the 3-phase overcurrent protection must be disabled to prevent unintended operation.

If measuring ground fault current using the optional core balance CT, see CSH Core Balance CT, page 74, for more information.

## Time Delay Measurement

Checking the protective systems involves measurement of trip time delays (figure 54). The procedure requires a double-contact switch: one contact controls the application of the injection signal, and the other starts a timer. The timer stops when one of the two normally open contacts (terminals 1A5 and 1A6, or 1A7 and 1A8) closes.

To measure trip time delays, follow these steps:

1. Set the current generator to the test value.
2. Initialize the timer to 0.
3. Start the current generator and timer at the same time, using the double-contact switch.

When the relay output contact closes, the timer indicates the tripping time.

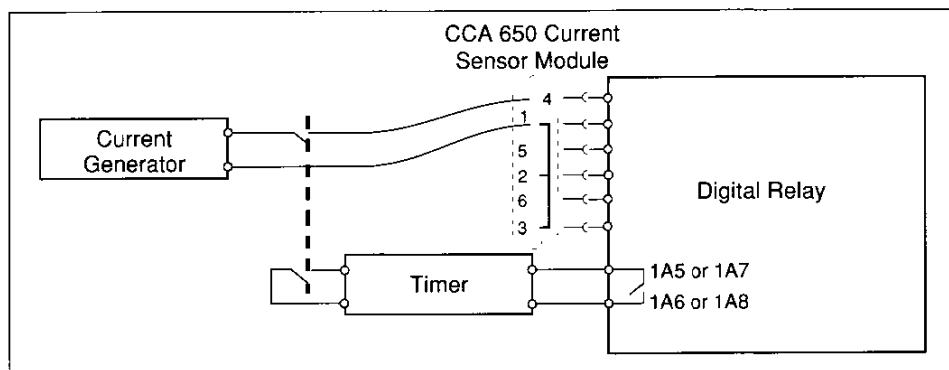

Figure 54: Time delay measurement

**METERING**

The digital relay provides metered data on the equipment being protected. Use the *meters* button to display the different measurements.

**Metered Values**

Metered values are shown in table 8 below.

**Table 8  
Measurement Characteristics**

Function	Name	Unit	Range	Accuracy ①	Refresh Period
Phase Currents	IA, IB, IC	A or kA	0.05 to 24 x PH CT ②	± 5% or ± 0.03 x PH CT	< 2 seconds
Maximum Demand	AMPDa, AMPDb, AMPDc	A or kA	0.05 to 24 x PH CT ②	± 5% or ± 0.03 x PH CT	5 minutes
Trip Currents Phase Zero Sequence	TRIPa, TRIPb, TRIPc TRIPg	A or kA A or kA	0.05 to 24 x PH CT ② 0.02 to 10 x GF CT ③	± 5% or ± 0.03 x PH CT ± 5% or ± 0.02 x GF CT or ± 0.1 A	—

① Under reference conditions (IEC 255-4).

② PH CT: CT primary rated current.

③ GF CT: CSH core balance CT relay input rating (2 A or 30 A) or standard zero sequence CT primary current rating.

**Metering Testing**

This function gives a continuous reading of the three phase currents.

**Operation**—The measurements of the “Ia,” “Ib,” and “Ic” currents are the averages obtained over a period of approximately 1.5 seconds.

**Testing**—To test the digital relay, follow these steps:

1. Inject across the 4–1 terminals (5–2 and 6–3 respectively) of the phase current sensor module (CCA 650) a 1 A or 5 A current, according to the current rating of the CT being used, and the DIP switch settings described on pages 15–16.
2. Press the *meters* button to read the measurement of “Ia,” “Ib,” and “Ic” respectively.
3. The measurement displayed should be the same as the value of PH CT set with the *device* button. The reading error should be less than the sum of the digital relay error (± 5%) and the current injection equipment error.

**Maximum Demand Ammeters**

The maximum demand ammeters indicate the peak 5 minute average value of current since the last reset.

**Operation**—The maximum demand ammeters:

- calculate the average of each phase current and store the highest average since the last zero reset
- all reset to zero by pressing the *reset* button when any one of them is shown on the display
- require 5 minutes for calculating each new average of the phase currents

**Testing**—Test the maximum demand ammeters by following these steps:

1. Inject a current I into the phase corresponding to the maximum demand being tested.
2. Reset the maximum demand ammeters to zero by displaying the maximum demand value for the corresponding phase being tested, and pressing the *reset* button. Perform this reset operation even if the maximum demand ammeters are already at zero; it allows the calculation to be started up for a new integration period.

**Maximum Demand  
Ammeters (cont.)****Phase And Ground  
Fault Trip Currents**

3. Wait for the end of the integration period (5 minutes) and read the value of the maximum demand ammeter.

Trip current metering indicates fault characteristics (phase and magnitude).

**Operation**—Trip current metering operates as follows:

- Trip current metering gives the maximum value of phase and ground fault current during the first 30 ms after the trip sequence is initiated.
- Zero reset is impossible. Each time tripping occurs, the new values replace the previous ones.
- If the trip current exceeds  $24 \times \text{PH CT}$ , the digital relay displays a message indicating that the phase fault current has exceeded the maximum trip current measurement (for example, "TRIPa > 24 kA").

**Testing**—To test, follow these steps:

1. Have one of the overcurrent elements trip the digital relay.
2. Read the values of "TRIPa," "TRIPb," "TRIPc," and "TRIPg."

### ANSI 50/51, AND EITHER 50N/51N OR 50G/51G SETTING AND TESTING

#### 3-Phase Overcurrent (ANSI 50/51) Settings

This section describes how to set ANSI 50/51, and either 50N/51N or 50G/51G settings. Also included are tests to ensure that the relay operates properly and the settings are valid.

**Operation**—the protection includes two pickup settings:

- definite time or inverse-time-overcurrent curves
- instantaneous or time-delayed instantaneous pickup

There are three parameters for the time overcurrent protection:

- time current curve: PH TCC
- current setting: PH CS
- time delay: PH TD

There are two parameters for the instantaneous protection:

- instantaneous pickup: PH IP
- instantaneous time delay: PH ITD

Tripping curves are shown in figures 55 and 56 below.

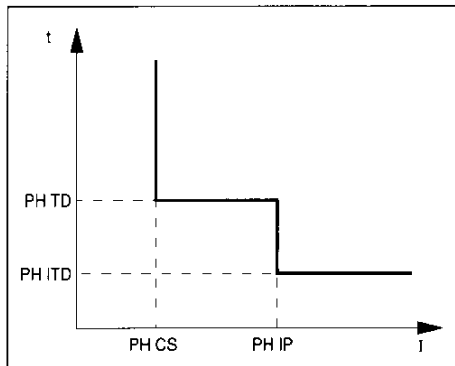

Figure 55: Definite time curve

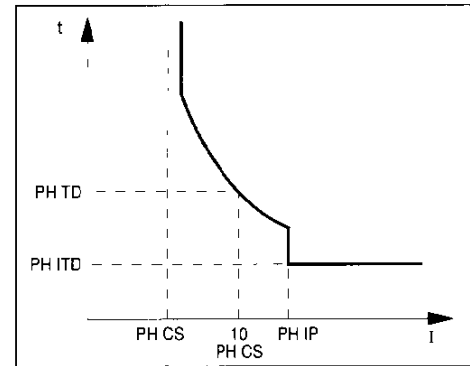

Figure 56: Inverse-time-overcurrent curve

**3-Phase Overcurrent (ANSI 50/51) Settings (cont.)**

Table 9 below shows the various settings for each 3-phase overcurrent parameter.

**Table 9  
3-Phase Overcurrent Parameter Settings**

Parameter	Settings
CT Primary Rated Current (PH CT)	A: 10 - 15 - 20 - 25 - 30 - 35 - 36 - 40 - 45 - 50 - 60 - 70 - 75 - 80 - 90 - 100 - 120 - 125 - 150 - 160 - 175 - 180 - 192 - 200 - 225 - 240 - 250 - 300 - 320 - 350 - 400 - 450 - 480 - 500 - 600 - 625 - 640 - 700 - 750 - 800 - 900 - 960 kA: 1 - 1.2 - 1.25 - 1.4 - 1.5 - 1.6 - 2 - 2.5 - 3 - 3.5 - 3.75 - 4 - 5 - 6 - 6.25
Curve (PH TCC)	DT - SIT - VIT - EIT - UIT - RI
Current Setting (PH CS in multiples of PH CT)	.3 - .35 - .4 - .45 - .5 - .55 - .6 - .65 - .7 - .75 - .8 - .85 - .9 - .95 - 1 - 1.1 - 1.2 - 1.3 - 1.4 - 1.5 - 1.6 - 1.7 - 1.8 - 1.9 - 2 - 2.2 - 2.4 - 2.6 - 2.8 - 3 - 3.5 - 4 - 4.5 - 5 - 5.5 - 6 - 6.5 - 7 - 7.5 - 8 - off For all inverse-time-overcurrent curves, the PH CS setting range is limited to 2.4 x PH CT.
Time Delay (PH TD)	ms: 100 - 200 - 300 - 400 - 500 - 600 - 700 - 800 - 900 s: 1.1 - 1.2 - 1.3 - 1.4 - 1.5 - 1.6 - 1.7 - 1.8 - 1.9 - 2 - 2.1 - 2.2 - 2.3 - 2.4 - 2.5 - 2.6 - 2.7 - 2.8 - 2.9 - 3 - 3.1 - 3.2 - 3.3 - 3.4 - 3.5 - 3.6 - 3.7 - 3.8 - 3.9 - 4 - 4.5 - 5 - 5.5 - 6 - 6.5 - 7 - 7.5 - 8 - 8.5 - 9 - 9.5 - 10 - 10.5 - 11 - 11.5 - 12 - 12.5 - 13 - 13.5 - 14 - 14.5 - 15 - 16 - 17 - 18 - 19 - 20 - 21 - 22 - 23 - 24 - 25 - 30 - 35 - 40 - 45 - 50 - 55 - 60 - 65 - 70 - 75 - 80 - 85 - 90 For all inverse-time-overcurrent curves, the PH TD maximum setting is 12.5 s.
Instantaneous Pickup (PH IP in multiples of PH CT)	1 - 2 - 3 - 4 - 5 - 6 - 7 - 8 - 9 - 10 - 11 - 12 - 13 - 14 - 15 - 16 - 17 - 18 - 19 - 20 - 21 - 22 - 23 - 24 - off
Instantaneous Time Delay (PH ITD)	"inst.": instantaneous, typical tripping time 25 ms. ms: 50 - 100 - 150 - 200 - 250 - 300 - 400 - 500 - 600 - 700 - 800 - 900 s: 1 - 1.1 - 1.2 - 1.3 - 1.4 - 1.5 - 1.6 - 1.7 - 1.8 - 1.9 - 2

*Note: PH CS is expressed as multiples of phase CT rating (PH CT). Amp tap of conventional induction disc relays is normally expressed in secondary amperes. See table 10 below for equivalent pickup settings (where the digital relay is configured for 5 A CT inputs).*

**Table 10  
Induction Disc Amp Tap/Digital Relay Current Setting Equivalents**

Induction Disc Amp Tap (amperes)	1.5	2	2.5	3	4	5	6	8	10	12
Digital Relay Current Setting (multiples of PH CT)	.3	.4	.5	.6	.8	1	1.2	1.6	2	2.4

**3-Phase Time Overcurrent Settings**

Protection settings are listed below. In all equations, I = trip current.

- **"PH TCC" setting**—"PH TCC" settings are listed below:
  - DT: definite time curve (figure 57, page 52)
  - RI: rapid inverse curve (figure 58, page 52)  
equation:  $t = \frac{0.315 \times \text{PH TD}}{0.339 - 0.236 \frac{I}{\text{PH CS}}} \text{ s}$
  - SIT: standard inverse time curve (figure 59, page 53)  
equation:  $t = \frac{0.047 \times \text{PH TD}}{(I/\text{PH CS})^{0.02} - 1} \text{ s}$
  - VIT: very inverse time (figure 60, page 53) or long time inverse (LTI) curve. The LTI curve is the very inverse time curve set with long time delays (longer than 3 s).  
equation:  $t = \frac{9 \times \text{PH TD}}{(I/\text{PH CS}) - 1} \text{ s}$
  - EIT: extremely inverse time curve (figure 61, page 54)  
equation:  $t = \frac{99 \times \text{PH TD}}{(I/\text{PH CS})^2 - 1} \text{ s}$
  - UIT: ultra inverse time curve (figure 62, page 54)  
equation:  $t = \frac{315 \times \text{PH TD}}{(I/\text{PH CS})^{2.5} - 1} \text{ s}$

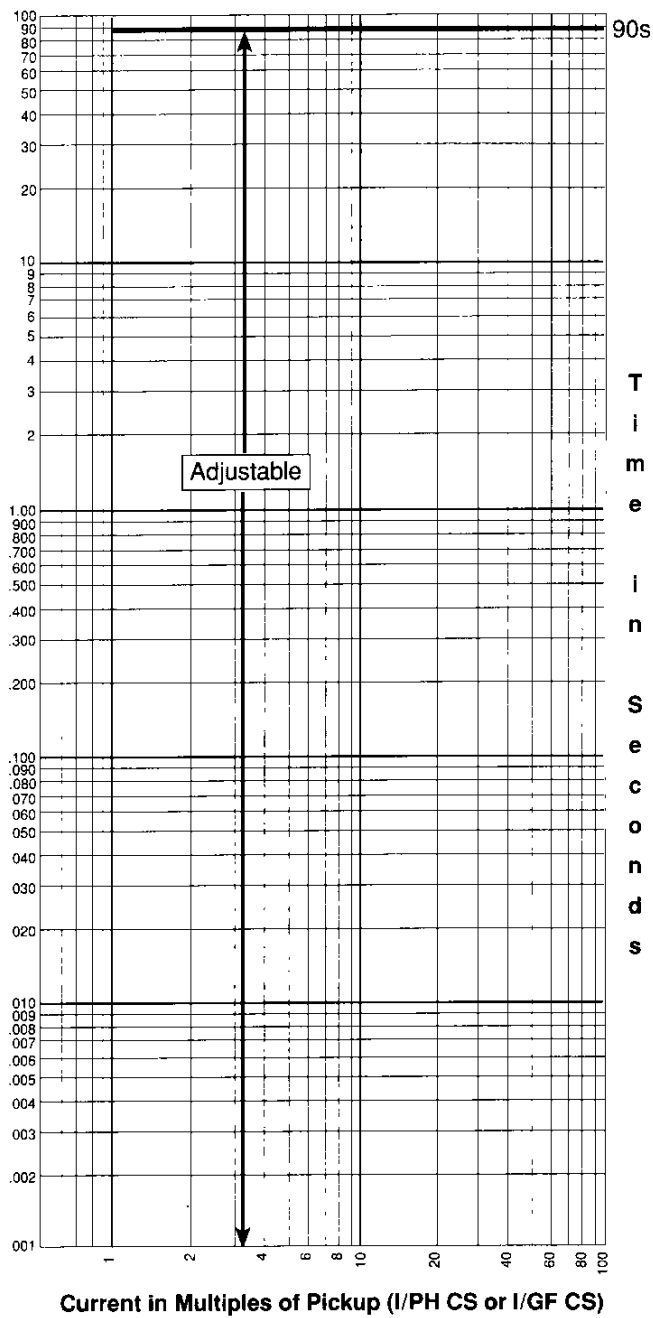

Figure 57: Definite time (DT) curve

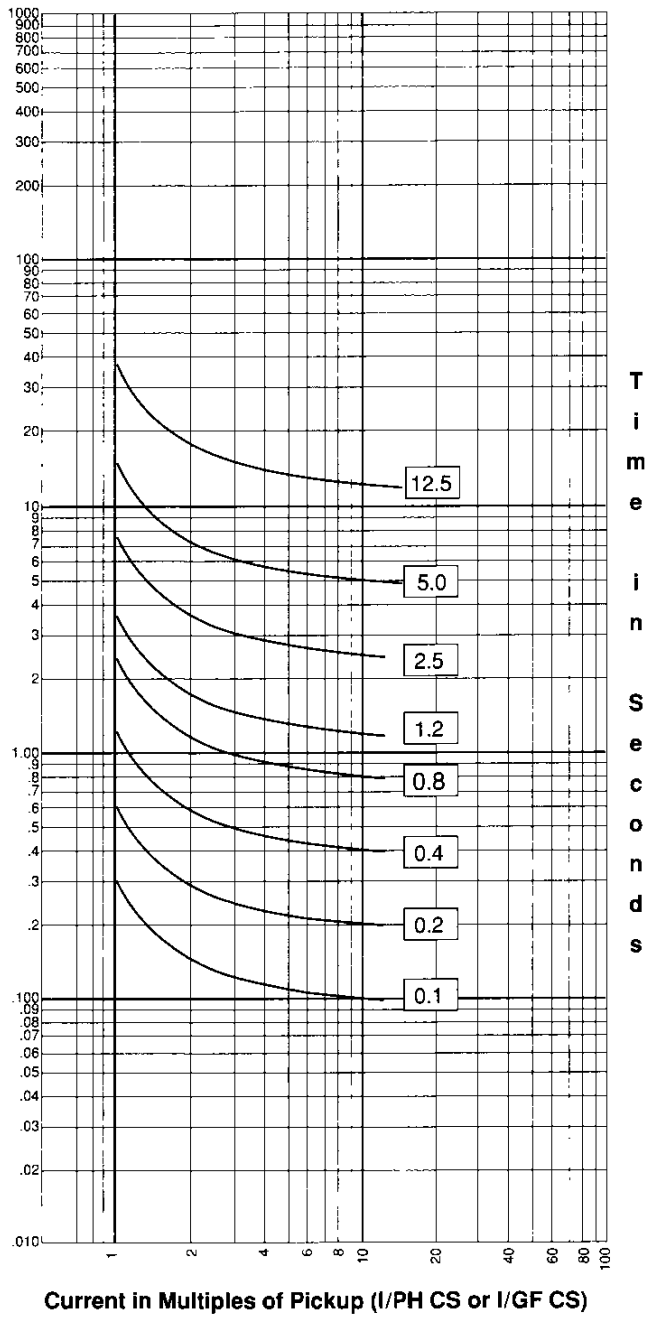
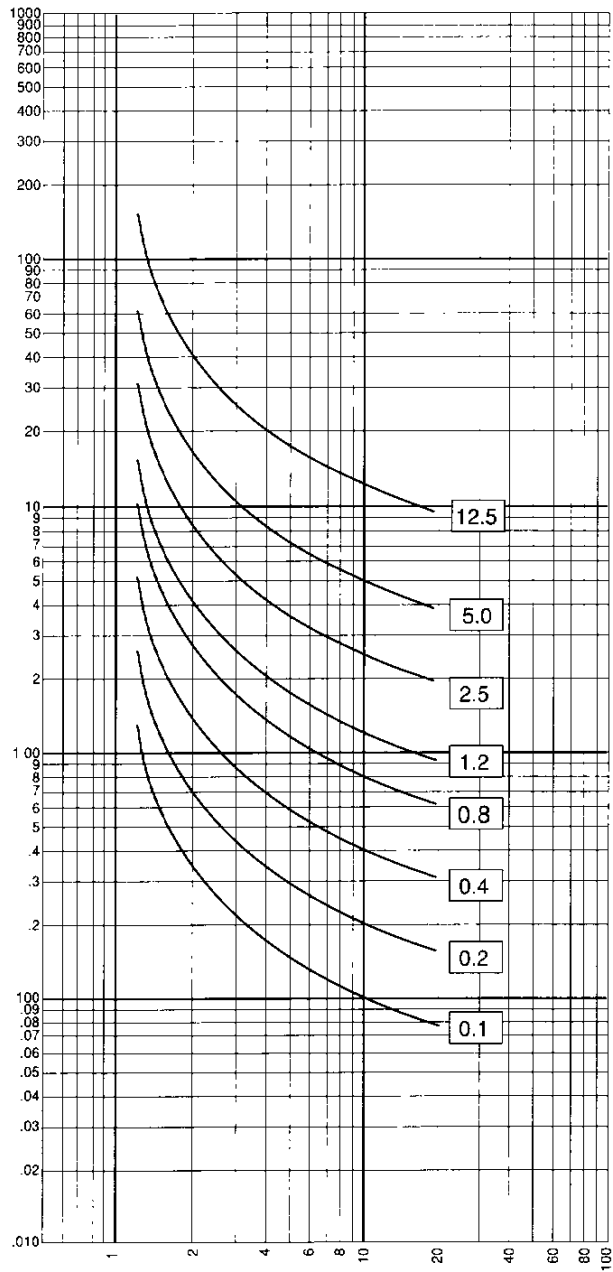
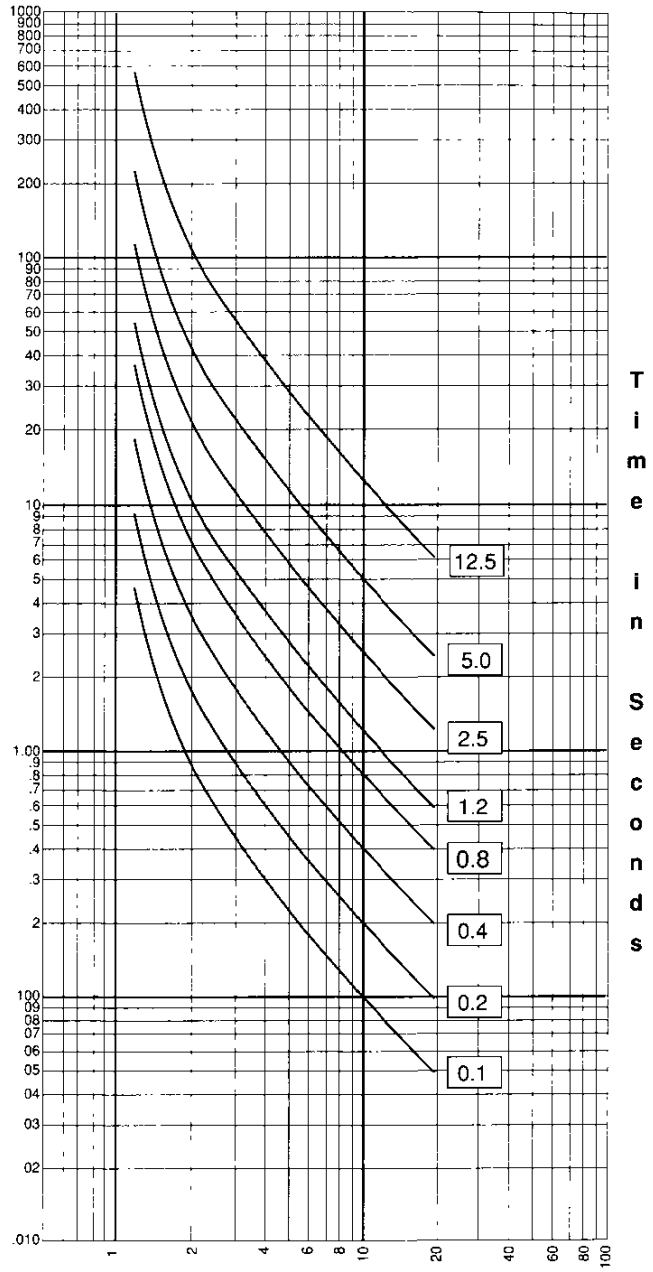

Figure 58: Rapid inverse (RI) curve



Current in Multiples of Pickup (I/PH CS or I/GF CS)

Figure 59: Standard inverse time (SIT) curve



Current in Multiples of Pickup (I/PH CS or I/GF CS)

Figure 60: Very inverse time (VIT) curve

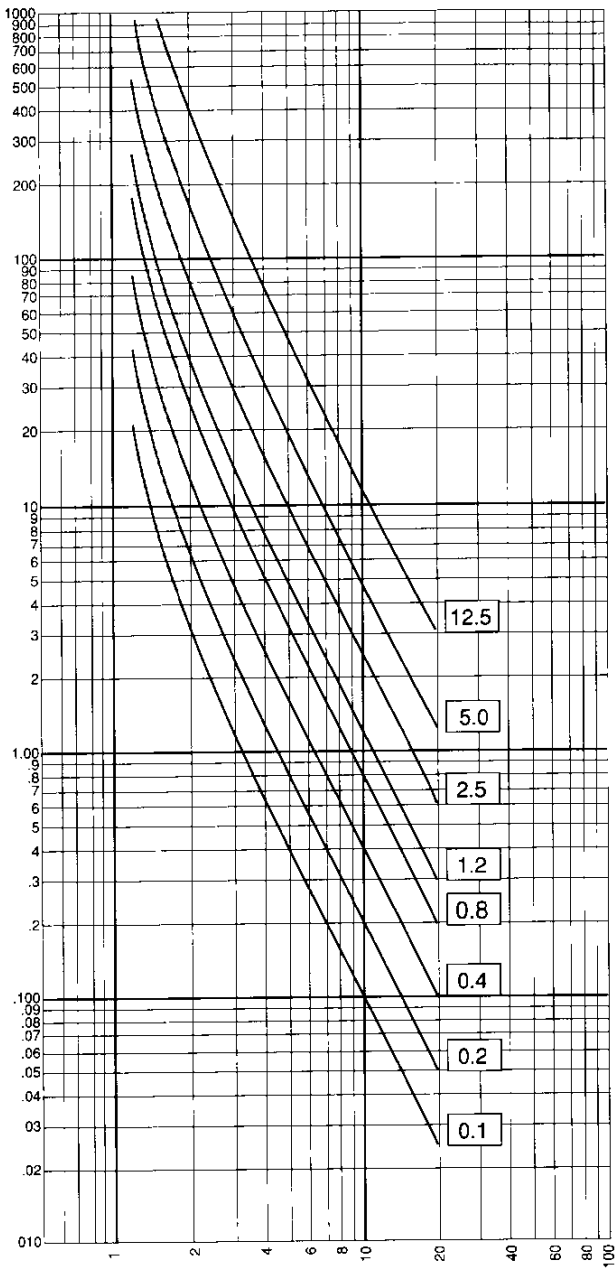

**Current in Multiples of Pickup (I/PH CS or I/GF CS)**

*Figure 61: Extremely inverse time (EIT) curve*

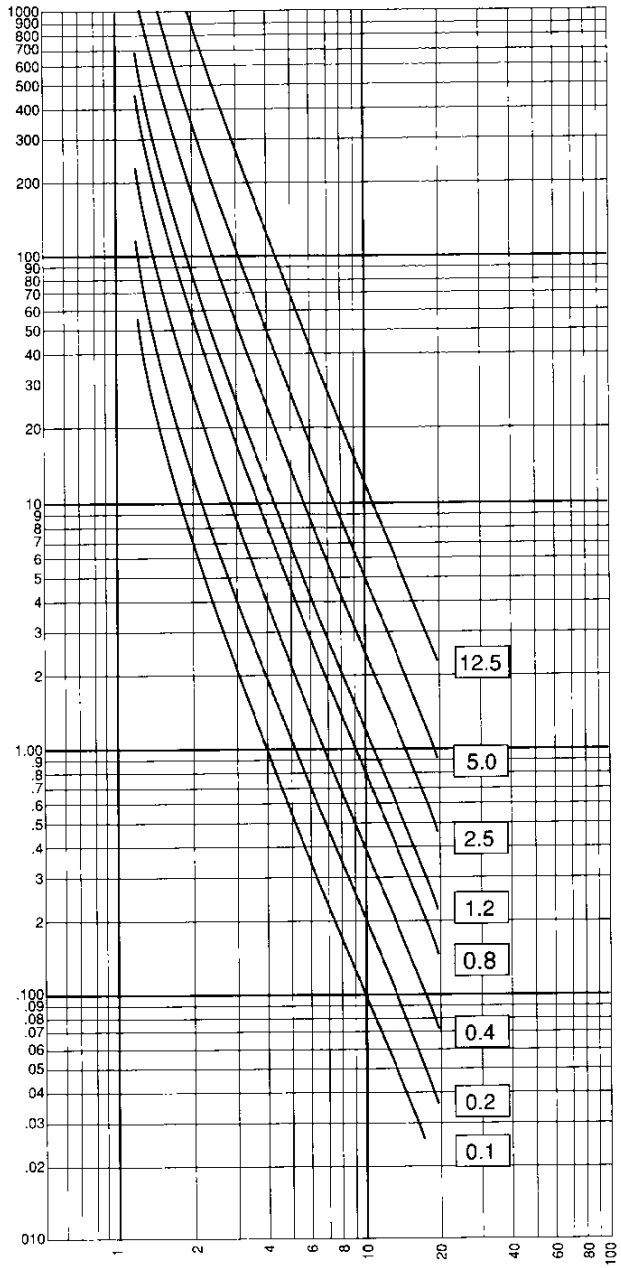

**Current in Multiples of Pickup (I/PH CS or I/GF CS)**

*Figure 62: Ultra inverse time (UIT) curve*

### 3-Phase Time Overcurrent Settings (cont.)

- **“PH CS” setting**—The “PH CS” settings are displayed in A or kA.

*Note:*

- Set “PH CS” after “PH CT” and “PH TCC” because the PH CS setting range depends on the “PH CT” and “PH TCC” parameters.
  - For the definite time curves and the RI curve, “PH CS” is the pickup.
  - For the other inverse-time-overcurrent curves, “PH CS” is the asymptote of the curve. The tripping pickup is  $1.2 \times$  “PH CS.”
  - The time overcurrent setting can be disabled by setting “PH CS” to “off.”
- **“PH TD” setting**—For inverse-time-overcurrent curves, the time delay “PH TD” is determined for a current value of  $10 \times$  “PH CS.” The following questions and answers help illustrate this.
    - Q. Knowing a point on the curve—for example, a tripping time  $T$  for a given current  $I$ —how is “PH TD” determined?
    - A. “PH TD” is determined as follows:
      1. Calculate the ratio  $I/\text{PH CS}$ .
      2. In table 10 on the next page, find the coefficient  $K$  for the selected type of curve that is the closest to the  $I/\text{PH CS}$  ratio.
      3. Calculate  $\text{PH TD} = T/K$ . From the list of possible PH TD settings, choose the closest one to the value obtained.

To simplify calculations,  $1/K$  values are also given in the table.

Example: with “PH CS”=180 A, an SIT curve which trips in 2 seconds for 600 A is required. Thus:

1.  $I/\text{PH CS} = 600/180 = 3.33$
2. The table gives for  $I/\text{PH CS} = 3.4$ :  $K = 1.88$  or  $1/K = 0.53$
3. Hence  $\text{PH TD} \approx 2 \times 0.53 = 1.06$  seconds

“PH TD”=1.1 seconds is chosen, being the closest setting.

Q. Once “PH TD” has been set, how are the tripping times close to a given current  $I$  found?

- A. Determine the tripping times close to a given current  $I$  as follows:
  1. Calculate the ratio  $I/\text{PH CS}$  (see table 11).
  2. In table 10, find the coefficient  $K$  for the selected type of curve that is the closest to the  $I/\text{PH CS}$  ratio.
  3. Calculate  $T = K \times \text{PH TD}$ , the tripping time for the current that corresponds to the  $I/\text{PH CS}$  ratio in the table.

Example: for PH CS=180 A, PH TD=1.1 s and a standard inverse time curve (SIT), what is the tripping time for a current close to 1 kA?

1.  $I/\text{PH CS} = 1000/180 = 5.55$
2. The table gives for  $I/\text{PH CS} = 5.6$ :  $K = 1.33$
3. Hence,  $T = 1.33 \times 1.1 = 1.46$  seconds for a current of  $180 \times 5.6 = 1.008$  kA.

**3-Phase Instantaneous Settings (cont.)**

- **"PH IP" setting**—The "PH IP" settings are displayed in A or kA.  
*Note: Set "PH IP" after "PH CT" because the "PH IP" setting range depends on "PH CT." To disable the phase instantaneous pickup, set "PH IP" to "off."*
- **"PH ITD" setting**—when "PH ITD" is set to "inst.," tripping time is approximately 25 ms.

**K Values**

Table 11 below determines the K values discussed on page 55.

**Table 11  
Digital Relay K Values**

I/PH CS	SIT		VIT		EIT		UIT		RI	
	K	1/K	K	1/K	K	1/K	K	1/K	K	1/K
1.0	—	—	—	—	—	—	—	—	3.06	0.327
1.2	12.9	0.0775	45.0	0.0222	225	0.00444	545	0.00183	2.21	0.452
1.4	6.92	0.144	22.5	0.0444	103	0.00971	239	0.00418	1.85	0.540
1.6	4.95	0.202	15.0	0.0667	63.5	0.0157	141	0.00709	1.64	0.610
1.8	3.95	0.253	11.2	0.0889	44.2	0.0226	94.1	0.0106	1.52	0.658
2.0	3.35	0.299	9.00	0.111	33.0	0.0303	67.6	0.0148	1.42	0.704
2.2	2.94	0.340	7.50	0.133	25.8	0.0388	51.0	0.0196	1.36	0.735
2.4	2.64	0.378	6.43	0.155	20.8	0.0481	39.8	0.0251	1.31	0.763
2.6	2.44	0.410	5.62	0.178	17.2	0.0581	31.8	0.0314	1.27	0.787
2.8	2.24	0.445	5.00	0.200	14.5	0.0690	26.0	0.0385	1.24	0.806
3.0	2.10	0.475	4.50	0.222	12.4	0.0806	21.6	0.0463	1.21	0.826
3.2	1.98	0.504	4.09	0.244	10.7	0.0934	18.2	0.0549	1.19	0.840
3.4	1.88	0.530	3.75	0.267	9.38	0.107	15.5	0.0646	1.17	0.854
3.6	1.80	0.556	3.46	0.289	8.28	0.121	13.4	0.0746	1.15	0.870
3.8	1.73	0.579	3.21	0.311	7.37	0.136	11.6	0.0862	1.14	0.877
4.0	1.66	0.602	3.00	0.333	6.60	0.152	10.2	0.0980	1.12	0.893
4.2	1.60	0.623	2.81	0.356	5.95	0.168	8.96	0.112	1.11	0.901
4.4	1.55	0.644	2.65	0.378	5.39	0.186	7.95	0.126	1.10	0.909
4.6	1.51	0.664	2.50	0.400	4.91	0.204	7.10	0.141	1.09	0.917
4.8	1.47	0.682	2.37	0.422	4.49	0.223	6.37	0.157	1.09	0.917
5.0	1.43	0.700	2.25	0.444	4.12	0.243	5.74	0.174	1.08	0.926
5.2	1.39	0.718	2.14	0.467	3.80	0.263	5.20	0.192	1.07	0.935
5.4	1.36	0.734	2.04	0.489	3.52	0.284	4.72	0.212	1.07	0.935
5.6	1.33	0.750	1.96	0.511	3.26	0.307	4.30	0.233	1.06	0.943
5.8	1.31	0.761	1.87	0.533	3.03	0.330	3.94	0.254	1.06	0.943
6.0	1.28	0.781	1.80	0.556	2.83	0.353	3.61	0.277	1.05	0.952
6.2	1.26	0.796	1.73	0.578	2.64	0.379	3.33	0.300	1.05	0.952
6.4	1.23	0.810	1.67	0.600	2.48	0.403	3.07	0.326	1.04	0.962
6.6	1.21	0.823	1.61	0.622	2.33	0.429	2.84	0.352	1.04	0.962
6.8	1.19	0.837	1.55	0.644	2.19	0.457	2.63	0.380	1.04	0.962
7.0	1.12	0.900	1.50	0.666	2.06	0.485	2.45	0.408	1.03	0.971
8.0	1.10	0.909	1.29	0.778	1.57	0.637	1.75	0.571	1.02	0.980
9.0	1.04	0.962	1.12	0.889	1.24	0.808	1.30	0.769	1.01	0.990
10	1.00	1.00	1.00	1.00	1.00	1.00	1.00	1.00	1.00	1.00
11	0.951	1.05	0.900	1.11	0.825	1.21	0.787	1.27	0.992	1.01
12	0.916	1.09	0.818	1.22	0.691	1.45	0.633	1.58	0.986	1.01
13	0.887	1.13	0.750	1.33	0.589	1.70	0.518	1.93	0.982	1.02
14	0.862	1.16	0.692	1.45	0.507	1.97	0.430	2.33	0.978	1.02
15	0.839	1.19	0.642	1.56	0.441	2.27	0.362	2.76	0.974	1.03
16	0.819	1.22	0.600	1.66	0.388	2.58	0.308	3.25	0.971	1.03
17	0.801	1.25	0.562	1.78	0.344	2.91	0.265	3.77	0.969	1.03
18	0.784	1.28	0.529	1.89	0.306	3.27	0.229	4.37	0.967	1.03
19	0.769	1.30	0.500	2.00	0.274	3.65	0.200	5.00	0.965	1.04
≥ 20	0.756	1.32	0.474	2.11	0.248	4.03	0.176	5.68	0.963	1.04

**Note:** Beyond 20 x PH CS or 24 x PH CT, all the curves are definite time curves.

## Testing

Testing ensures the settings operate correctly.

The following procedure is explained for the complete 3-phase overcurrent system, including the instantaneous pickup and the overcurrent pickup. Because it will interfere with phase fault testing, be sure to disable the ground fault current setting if it operates by phase current summation.

*Note: To bypass the ground fault overcurrent system, inject the same current in two phases in opposite directions, but do not inject current into the third phase!*

**Instantaneous Pickup Check**

To check the instantaneous pickup (figure 63), follow these steps:

1. If necessary, disable the time-overcurrent pickup by setting "PH CS" to "off."
2. Gradually inject current until the alarm message "PHASE FAULT" appears.
3. The instantaneous pickup is the current value at which the message appears.

**Time-Overcurrent Pickup Check**

To check the time-overcurrent pickup (figure 64), follow these steps:

1. Reset the current setting parameter "PH CS" to a numeric value.
2. Gradually inject current until the alarm message "PHASE FAULT" appears.
3. The current setting is the current value at which the message appears. Remember, for definite time (and RI curve), the pickup is "PH CS." For inverse-time-overcurrent, the pickup is  $1.2 \times \text{"PH CS."}$

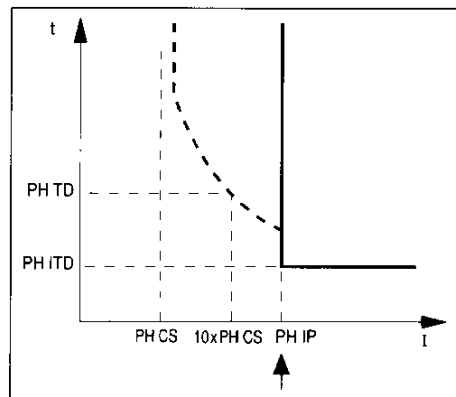

Figure 63: Instantaneous pickup check

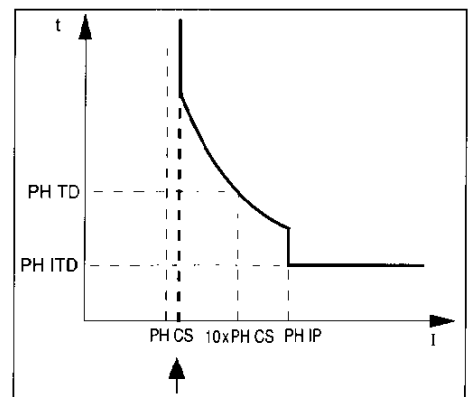

Figure 64: Time-overcurrent pickup check



**3-Phase Overcurrent Test Results**

Record results from the phase protection tests in table 13 below. If you might use this chart more than once, photocopy this page and enter values on a photocopy instead of the original.

**Table 13  
3-Phase Overcurrent Test Results**

Overcurrent Settings		Expected Value	Measured Value
Current Settings	PH TCC = DT/RI	PH CS	
	SIT/VIT	1.2 x PH CS	
	EIT/UIT		
Time Delay For 10 x PH CS		PH TD	
Time Delay For 2 x PH CS	PH TCC = DT	1 x PH TD	
	SIT	3.35 x PH TD	
	VIT	9 x PH TD	
	EIT	33 x PH TD	
	UIT	67.6 x PH TD	
	RI	1.42 x PH TD	
<b>Instantaneous Pickup Settings</b>			
Instantaneous Pickup		PH IP	
Instantaneous Time Delay		PH ITD	
Date:			
Signatures:			

## Ground Fault Overcurrent (ANSI 50N/51N or 50G/51G) Protection

### Operation

This feature provides ANSI 50N/51N or 50G/51G functions for phase-to-ground faults in resistive grounded, reactive grounded, and solidly grounded networks.

There are two ways to measure ground fault current. The standard (default) method is by internal vector summation of the three phase currents. The second method to determine ground fault current is by using an optional CSH core balance CT; see **CSH Core Balance CT**, page 74, for information.

Refer to the **Ground Fault Current Measurement Method Summary** table on page 79.

The ANSI 50N/51N and 50G/51G functions include two pickup settings:

- definite time (figure 68) or inverse-time-overcurrent curves (figure 69)
- instantaneous or time-delayed instantaneous pickup

There are three parameters for the time-overcurrent protection:

- time current curve: "GF TCC"
- current setting: "GF CS"
- time delay: "GF TD"

There are two parameters for the instantaneous protection:

- instantaneous pickup: "GF IP"
- instantaneous time delay: "GF ITD"

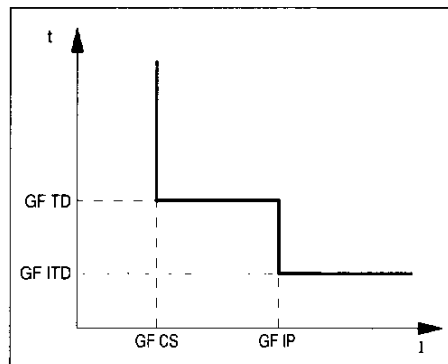

Figure 68: Definite time curve

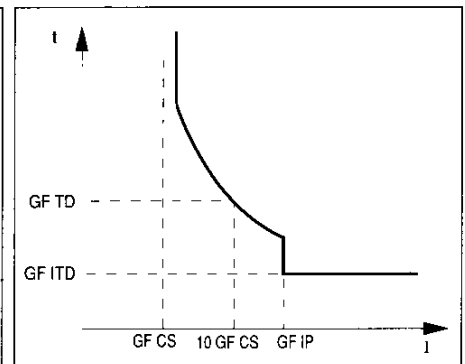

Figure 69: Inverse-time-overcurrent curve

Operation (cont.)

Table 14 below shows the various settings available for each of the ground fault overcurrent parameters.

**Table 14**  
**Ground Fault Overcurrent Parameter Settings**

Parameters	Settings
CT primary rated current (GF CT)	Residual (50N/51N) "GF CT=PH CT": sum of the three phase currents.
	CSH 120 or CSH 200 "Tor 2A": 2 A input rating, CSH core balance CTs: equivalent to GF CT=2 A. "Tor30A": 30 A input rating, CSH core balance CTs: equivalent to GF CT= 30 A.
	Standard zero sequence CT with interposing CSH 30 A: 1 - 2 - 3 - 4 - 5 - 6 - 10 - 15 - 20 - 25 - 30 - 35 - 36 - 40 - 45 - 50 - 60 - 70 - 75 - 80 - 90 - 100 - 120 - 125 - 150 - 160 - 175 - 180 - 192 - 200 - 225 - 240 - 250 - 300 - 320 - 350 - 400 - 450 - 480 - 500 - 600 - 625 - 640 - 00 - 750 - 800 - 900 - 960. kA: 1 - 1.2 - 1.25 - 1.4 - 1.5 - 1.6 - 2 - 2.5 - 3 - 3.5 - 3.75 - 4 - 5 - 6 - 6.25
Curve (GF TCC)	DT - SIT - VIT - EIT - UIT - RI
Current Setting (GF CS in multiples of GF CT)	.05 - .1 - .15 - .2 - .25 - .3 - .35 - .4 - .45 - .5 - .55 - .6 - .65 - .7 - .75 - .8 - .9 - .95 - 1 - 1.1 - 1.2 - 1.3 - 1.4 - 1.5 - 1.6 - 1.7 - 1.8 - 1.9 - 2 - off
Time Delay (GF TD)	ms: 100 - 200 - 300 - 400 - 500 - 600 - 700 - 800 - 900 s: 1.1 - 1.2 - 1.3 - 1.4 - 1.5 - 1.6 - 1.7 - 1.8 - 1.9 - 2 - 2.1 - 2.2 - 2.3 - 2.4 - 2.5 - 2.6 - 2.7 - 2.8 - 2.9 - 3 - 3.1 - 3.2 - 3.3 - 3.4 - 3.5 - 3.6 - 3.7 - 3.8 - 3.9 - 4 - 4.5 - 5 - 5.5 - 6 - 6.5 - 7 - 7.5 - 8 - 8.5 - 9 - 9.5 - 10 - 10.5 - 11 - 11.5 - 12 - 12.5 - 13 - 13.5 - 14 - 14.5 - 15 - 16 - 17 - 18 - 19 - 20 - 21 - 22 - 23 - 24 - 25 - 30 - 35 - 40 - 45 - 50 - 55 - 60 - 65 - 70 - 75 - 80 - 85 - 90 For all inverse-time-overcurrent curves, the GF TD maximum setting is 12.5 s.
Instantaneous Pickup (GF IP in multiples of GF CT)	0.5 - .1 - .15 - .2 - .25 - .3 - .35 - .4 - .45 - .5 - .55 - .6 - .65 - .7 - .75 - .8 - .85 - .9 - .95 - 1 - 1.1 - 1.2 - 1.3 - 1.4 - 1.5 - 1.6 - 1.7 - 1.8 - 1.9 - 2 - 2.5 - 3 - 4 - 5 - 6 - 7 - 8 - 9 - 10 - off
GF ITD	"inst.": instantaneous, typical tripping time 25 ms. ms: 50 - 100 - 150 - 200 - 250 - 300 - 400 - 500 - 600 - 700 - 800 - 900 s: 1 - 1.1 - 1.2 - 1.3 - 1.4 - 1.5 - 1.6 - 1.7 - 1.8 - 1.9 - 2

**Ground Fault Overcurrent Setting**

*Important: Saturation of CTs during transient operation can result in a false ground fault current of up to 5% of phase currents. To avoid nuisance tripping, consider this when selecting ground fault settings. Two examples are shown below.*

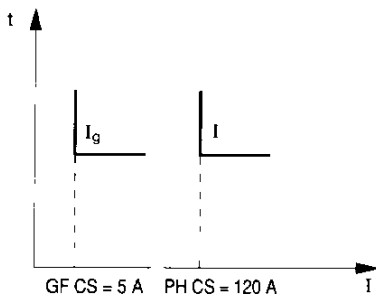

Figure 70: Pickup too low

**Causes of nuisance tripping:**

1. pickup too low: <10% of "PH CT" (figure 70)

example: "PH CT"=100 A  
"PH CS"=120 A  
"GF CS"=5 A

When a 100 A phase current flows through the network, the false ground fault current can reach 5 A, causing a trip due to ground fault overcurrent.

2. ground fault time delay shorter than phase time delay (figure 71)

example: "PH CT"=100 A  
"PH CS"=120 A "PH TD"=500 ms  
"GF CS"=50 A "GF TD"=200 ms

When a line-to-line fault creates a 2 kA current, the false ground fault current can reach 100 A, resulting in a trip in 200 ms. This trip, caused by the false ground fault current, occurs before the phase time delay ends.

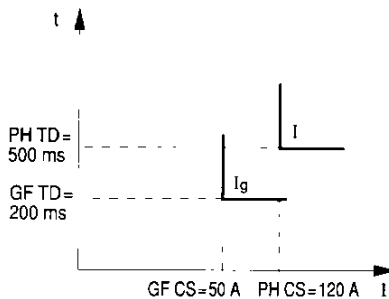

Figure 71: Ground fault time delay shorter than phase time delay

**GF CS**

The "GF CS" settings are displayed in A or kA. Set "GF CS" after "PH CT," "GF CT," and "GF TCC"; the "GF CS" setting range may depend on those three parameters.

For definite time curves and the RI curve, "GF CS" is the tripping value. For the other inverse-time-overcurrent curves, "GF CS" is the asymptote of the curve. The tripping value is situated at  $1.2 \times$  "GF CS."

The ground fault time-overcurrent function can be disabled by setting "GF CS" to "off."

**GF TCC**

The setup procedure is the same as for "PH TCC" (see **PH TCC Setting** under **3-Phase Time Overcurrent Settings**, page 51).

**GF TD**

The setup procedure is the same as "PH TD" (see **PH TD Setting** under **3-Phase Time Overcurrent Settings**, page 55). Beyond  $20 \times$  "GF CS" or  $10 \times$  "GF CT," all the curves are definite time curves.

**GF IP**

The "GF IP" settings are displayed in A or kA. Set "GF IP" after "GF CT" and "PH CT" because the "GF IP" setting range may depend on those parameters. The ground fault instantaneous overcurrent function can be disabled by setting "GF IP" to "off."

**GF ITD**

When "GF ITD" is set to "inst.," tripping time is approximately 25 ms.

**Testing**

Testing ensures the settings operate correctly.

The testing procedure is explained for the complete ground fault overcurrent system, including the instantaneous pickup and the time-overcurrent pickup. If using the optional CSH core balance CT, see **CSH Core Balance CTs**, page 74.

**Instantaneous Pickup Check**

Follow these steps to check the instantaneous pickup (figure 72):

1. If necessary, disable the time-overcurrent pickup by setting "GFCS" to "off."
2. Gradually inject current until the alarm message "GND FAULT" appears.
3. The instantaneous pickup is the current value at which the message appears.

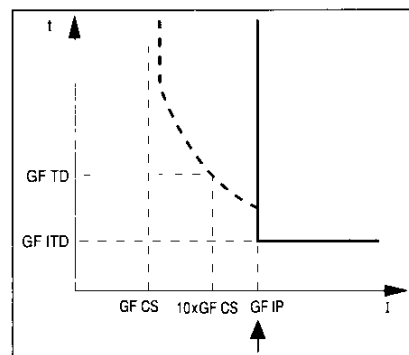

Figure 72: Instantaneous pickup check

**Time-Overcurrent Pickup Check**

Follow these steps to check the time-overcurrent pickup (figure 73):

1. Reset the current setting parameter "GFCS" to a numeric value.
2. Gradually inject current until the alarm message "GND FAULT" appears.
3. The current setting is the current value at which the message appears.

Reminder: For definite time (and RI curve), the pickup is "GFCS." For inverse-time-overcurrent curves, the pickup is  $1.2 \times \text{"GFCS."}$

**Time Delay Check  
( $10 \times \text{"GFCS"}$ )**

Referring to figure 74, follow these steps to check the time overcurrent time delay ( $10 \times \text{"GFCS"}$ ):

1. For inverse-time-current curves, measure the time delay at  $10 \times \text{"GFCS"}$  to find the set value of "GF TD."
2. If the instantaneous pickup "GF IP" is less than or equal to  $10 \times \text{"GFCS"}$ , disable it during testing ("off") so as not to measure "GF ITD" instead of "GF TD."
3. Measure the tripping time for the current that corresponds to  $10 \times \text{"GFCS"}$ . Expected accuracy (for "GFCS" > "GF CT") is  $\pm 5\%$ , not to exceed 60 ms.

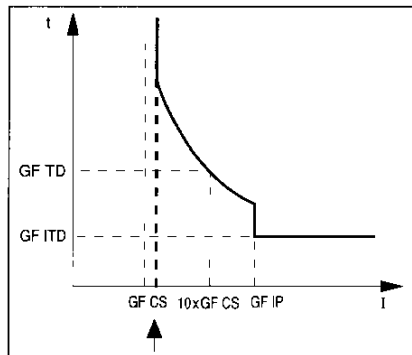

Figure 73: Overcurrent pickup check

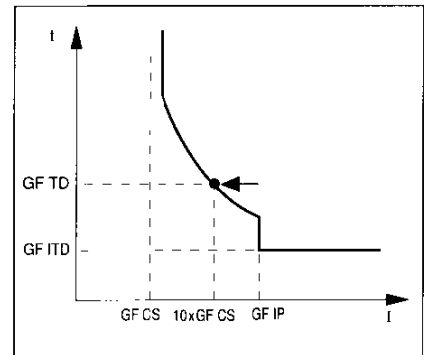

Figure 74: Time delay check ( $10 \times \text{GF CS}$ )

**Curve Type Check ( $2 \times \text{"GFCS"}$ )**

To check the curve type ( $2 \times \text{"GFCS"}$ ), measure the tripping time for the current corresponding to  $2 \times \text{"GFCS"}$ . Expected accuracy (for "GFCS" >  $0.2 \times \text{"GF CT"}$ ) is  $\pm 12.5\%$ . See figure 75.

**Instantaneous  
Time Delay Check**

To check the instantaneous time delay, measure the tripping time for a current that is at least 1.3 times greater than the instantaneous pickup. See figure 76.

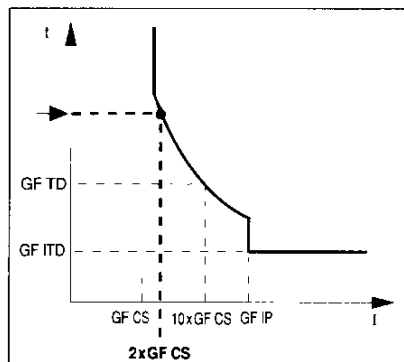

Figure 75: Curve type check ( $2 \times \text{GF CS}$ )

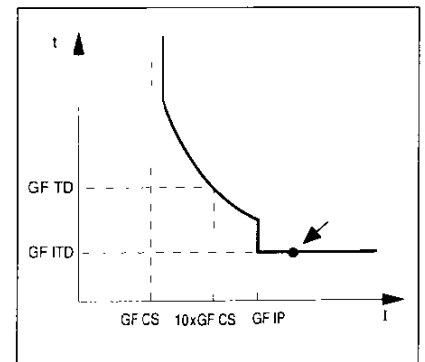

Figure 76: Instantaneous time delay check

**ANSI 50G/51G or 50N/51N**

**Installation Characteristics**

Record installation characteristics and digital relay settings in table 15 below. If you might use this table more than once, photocopy this page and enter values on a photocopy instead of the original.

**Table 15**  
**ANSI 50N/51N or 50G/51G Installation Characteristics**

Serial Number																			
<b>Installation</b>																			
Equipment																			
Cubicle																			
Phase CT Ratio																			
<b>Digital Relay Settings</b>																			
Rated Current	GF CT																		
Type Of Curve	GF TCC																		
Current Setting	GF CS																		
Time Delay	GF TD																		
Instantaneous Pickup	GF IP																		
Instantaneous Time Delay	GF ITD																		
SW1 DIP Switches (no. 1 to 2)	<table border="1"> <tr> <td>1</td> <td><input type="checkbox"/></td> <td><input type="checkbox"/></td> </tr> <tr> <td>2</td> <td><input type="checkbox"/></td> <td><input type="checkbox"/></td> </tr> </table> SW1	1	<input type="checkbox"/>	<input type="checkbox"/>	2	<input type="checkbox"/>	<input type="checkbox"/>												
1	<input type="checkbox"/>	<input type="checkbox"/>																	
2	<input type="checkbox"/>	<input type="checkbox"/>																	
SW2 DIP Switches (no. 1 to 6)	<table border="1"> <tr> <td>1</td> <td><input type="checkbox"/></td> <td><input type="checkbox"/></td> </tr> <tr> <td></td> <td><input type="checkbox"/></td> <td><input type="checkbox"/></td> </tr> <tr> <td></td> <td><input type="checkbox"/></td> <td><input type="checkbox"/></td> </tr> <tr> <td></td> <td><input type="checkbox"/></td> <td><input type="checkbox"/></td> </tr> <tr> <td></td> <td><input type="checkbox"/></td> <td><input type="checkbox"/></td> </tr> <tr> <td>6</td> <td><input type="checkbox"/></td> <td><input type="checkbox"/></td> </tr> </table> SW2	1	<input type="checkbox"/>	<input type="checkbox"/>		<input type="checkbox"/>	<input type="checkbox"/>		<input type="checkbox"/>	<input type="checkbox"/>		<input type="checkbox"/>	<input type="checkbox"/>		<input type="checkbox"/>	<input type="checkbox"/>	6	<input type="checkbox"/>	<input type="checkbox"/>
1	<input type="checkbox"/>	<input type="checkbox"/>																	
	<input type="checkbox"/>	<input type="checkbox"/>																	
	<input type="checkbox"/>	<input type="checkbox"/>																	
	<input type="checkbox"/>	<input type="checkbox"/>																	
	<input type="checkbox"/>	<input type="checkbox"/>																	
6	<input type="checkbox"/>	<input type="checkbox"/>																	
CSH Core Balance CT Wiring (optional)																			

**Ground Fault Overcurrent Test Results**

Record results from the ground fault protection tests in table 16 below. If you might use this table more than once, photocopy this page and enter values on a photocopy instead of the original.

**Table 16  
Ground Fault Overcurrent Test Results**

Test	Expected Value	Measured Value
<b>Overcurrent Setting</b>		
Current Setting	GF TCC = DT/RI GF CS	
	SIT/VIT ) EIT/UIT ) 1.2 x GF CS	
Time Delay For 10 x GF CS	GF TD	
Time Delay for 2 x GF CS	GF TCC=DT 1 x GF TD	
	SIT 3.35 x GF TD	
	VIT 9 x GF TD	
	EIT 33 x GF TD	
	UIT 67.6 x GF TD	
	RI 1.42 x GF TD	
<b>Instantaneous Pickup Settings</b>		
Instantaneous Pickup	GF IP	
Instantaneous Time Delay	GF ITD	
Date:		
Signatures:		



## CHAPTER 9—MAINTENANCE AND TROUBLESHOOTING

### MAINTENANCE

The digital relay does not require regular maintenance, nor does it contain any user-serviceable parts. If the digital relay requires service, contact your local Square D sales representative, or call the POWERLOGIC Technical Support Center for assistance. See **Getting Technical Support** below.

### ! CAUTION

#### HAZARD OF EQUIPMENT DAMAGE.

**Never open the digital relay. Opening the digital relay voids the warranty.**

Failure to observe this precaution can result in equipment damage.

### GETTING TECHNICAL SUPPORT

For technical support, contact the POWERLOGIC Technical Support Center in one of the following two ways:

- Fax your request for support to (615) 459-4294, 24 hours a day, seven days a week. Be sure to include your name and company, address, phone number, type(s) of POWERLOGIC product(s), and a detailed description of your problem. The support center will normally respond within two business hours. Business hours are 7:30 A.M. to 4:30 P.M., Central Time, Monday through Friday—except holidays.
- Phone (615) 459-8552, 7:30 A.M. to 4:30 P.M., Central Time, Monday through Friday (except holidays) for assistance from a technical support specialist. If a technical support specialist is not available, leave a voice mail message or, in an urgent situation, speak to an operator who will process your request. The support center normally responds within two business hours.

### TROUBLESHOOTING

Table 17, page 68, lists problems encountered with POWERLOGIC digital relays, their causes, and remedies. This table is of a general nature and covers only the main causes of problems.

#### Lamp Test

Test the status indicators and display by simultaneously pressing the *meters* and *device* buttons. All indicators and LCDs will activate.

**Table 17**  
**Troubleshooting**

Problem	Cause/Solution
The "CHECK SETTINGS" message is displayed.	Caused by a change in the setting of one of the "PH CT," "GF CT," "PH TCC," or "GF TCC" parameters. See <b>Conflicting Settings</b> , page 38.
The -, +, and <i>enter</i> buttons are disabled.	Switch to the parameter setting mode. See <b>Setup Mode</b> , page 35.
The self-diagnostic indicator is on and the display is continuously off.	The digital relay self-monitoring functions have detected an internal failure. The digital relay is out of service. Contact Technical Support (see <b>Getting Technical Support</b> , page 67).
The <i>on</i> indicator does not activate when the digital relay is switched on.	There is a problem with the digital relay power supply. Check to ensure the supply voltage is within the permitted range for the digital relay. Check the control power supply wiring (terminals 1A1 [+] and 1A2 [-]). If the supply voltage is normal and the control power supply wiring appears normal, the digital relay is out of service. Contact Technical Support (see <b>Getting Technical Support</b> , page 67).
The phase protection pickups are incorrect.	Check the settings. Check the rated frequency setting "FREQ" ( <i>device</i> button). Check the rated current setting "PH CT" and the SW2 DIP switch settings.
The phase current measurements are incorrect.	Check the settings. Check the rated frequency setting "FREQ" ( <i>device</i> button). Check the rated current setting "PH CT" and the SW2 DIP switch settings.
The ground fault protection pickups are incorrect.	Check the wiring and settings. Check the rated frequency setting "FREQ" ( <i>device</i> button). While referring to the <b>Ground Fault Current Measurement Method Summary Table</b> , page 79, check the rated current setting "GF CT," the SW2 DIP switch settings, and the CSH core balance CT wiring (if applicable).
Can't communicate with the digital relay from a remote personal computer.	Possible causes and solutions are listed below: <ul style="list-style-type: none"> <li>• Cause: The digital relay address is incorrect. Solution: Verify that the digital relay is correctly addressed. See <b>Setting the Device Address</b>, page 45.</li> <li>• Cause: The digital relay's baud rate is incorrect. Solution: Verify that the baud rate of the digital relay matches the baud rate of all other devices on its communications link. See <b>Setting the Baud Rate</b>, page 45, for instructions.</li> <li>• Cause: Communications lines are improperly biased. Solution: Verify that a multipoint communications adapter is being properly used to bias the communications lines. See <b>Biasing the Communications Link</b>, page 28, for instructions.</li> <li>• Cause: Communications lines are improperly terminated. Solution: Verify that a multipoint communications terminator is properly installed. See <b>Terminating the Communications Link</b>, page 30.</li> <li>• Cause: Incorrect route statement to the digital relay. Solution: Check route statement. Refer to the software instruction bulletin for instructions on defining route statements.</li> <li>• Cause: The communications card is damaged; this is indicated by the green <i>TX</i> LED not activating when a SY/MAX message is sent to the digital relay.</li> <li>• Solution: Contact your local Square D representative.</li> </ul>

## APPENDIX A—SPECIFICATIONS

### Electrical Characteristics

#### Phase Current Inputs

<u>Current Sensor Module Input (CT Secondaries)</u>	<u>Burden</u>
1 A CT configuration (SW2=all switches in "1" position)	<0.001 VA
5 A CT configuration (SW2=all switches in "0" position)	<0.025 VA

CT Primary Ratings ..... 10 A–6250 A

#### Status Input

Voltage Range .....	20–138 Vac/Vdc
Input Current Draw (max.) .....	3 mA @ 20 V; 6 mA @ 138 V
Must Turn Off Voltage (max.) .....	8.0 Vac/Vdc
Must Turn On Voltage (min.) .....	20 Vac/Vdc

#### Relay Output Contact (1)

	<u>@ 48 Vdc</u>	<u>@ 127 Vdc/Vac</u>
Rated Current	8 A	8 A
Breaking Capacity—dc Resistive Load	4 A	0.7 A
—ac Resistive Load		8 A

#### Relay Output Contacts (2, 3) and Watchdog Contacts (4, 5)

	<u>@ 48 Vdc</u>	<u>@ 127 Vdc/Vac</u>
Rated Current	8 A	8 A
Breaking Capacity—dc Resistive Load	2 A	0.3 A
—ac Resistive Load		4 A

#### Control Power Inputs

<u>Voltage</u>	<u>Voltage Range</u>	<u>Burden</u>	<u>Inrush Current</u>	<u>Operating Frequency</u>
100–127 Vac	–20%, +10%	16 VA	<18 A for 10 ms	47.5–63 Hz
48–125 Vdc	±20%	12 W	<12 A for 10 ms	

### Physical Specifications

Weight .....	7.72 lbs (3.5 kg)
Dimensions .....	See page 12

**Regulatory/Standards  
 Compliance**

**Environmental**

	Standard	Class	Specifications
Operating Temperature	IEC 68-2		-5 to +55°C <sup>①</sup>
Storage Temperature	IEC 68-2		-25 to +70°C
Humidity (Damp Heat) <sup>②</sup>	IEC 68-2		95% to 40°C
Corrosion Resistance <sup>②</sup>	IEC 654-4	Class I	

**Mechanical**

Degree of Protection	IEC 529	IP .51	Front Face
Vibration <sup>②</sup>	IEC 255-21-1	Class I	
Shock <sup>②</sup>	IEC 255-21-2	Class I	
Fire	NFC 20455		Glow Wire

**Safety**

UL 508

**Dielectric Withstand**

IEC 255-4<sup>③</sup>  
 UL 508  
 2 kV for 1 minute

**Electromagnetic**

Radiated Emissions	FCC Part 15	Class A	
Conducted Emissions	FCC Part 15	Class A	
RF Immunity <sup>②</sup>	IEC 255-22-3	Class X	30 V/m
Electrostatic Discharge	IEC 255-22-2	Class III	

**Electrical**

1.2/50 $\mu$ s Impulse Wave Withstand	IEC 255-4 <sup>③</sup>		2 kV for 1 minute
Damped 1 MHz Sine Wave	IEC 255-22-1	Class III	
5 ns Fast Transients	IEC 255-22-4	Class IV	
Immunity To Surge	IEC 801-5		

<sup>①</sup> Ambient cubicle temperature. Relay components maximum operating temperature=70°C.

<sup>②</sup> At time of publication, testing limited to models DR-LXS01 X0A TBN and DR-LXS01 X0A TEN.

<sup>③</sup> Printed in 1976 and amended in 1979.

## APPENDIX B—GLOSSARY

### “AmpDa”

Phase A current maximum block demand.

### “AmpDb”

Phase B current maximum block demand.

### “AmpDc”

Phase C current maximum block demand.

### “Ia”

Phase A current measurement.

### “Ib”

Phase B current measurement.

### “Ic”

Phase C current measurement.

### CCA 650

Phase current sensor module.

### CCA 604

4-position removable terminal block.

### CCA 606

6-position removable terminal block.

### CCA 608

8-position removable terminal block.

### “CHECK SETTINGS”

Message which appears when a setting change (PH CT, GF CT, PH TCC, or GF TCC) automatically modifies other settings. The modified values must be reset or validated.

### Core Balance CT

Current transformer used to measure ground fault current. Secondary current: 1 A or 5 A.

### CSH

Name of core balance CTs used with the digital relay.

### device

Button used to read and set general parameters.

### DT

Definite time. Setting that is chosen for a definite time curve.

### EIT

Extremely inverse time. Setting that is chosen for an extremely inverse time curve.

### enter

Button used to store the displayed settings (operational only in parameter setting mode).

### “FREQ”

Rated network frequency. Parameter set during commissioning.

### “GF CS”

Ground fault current setting. This is equal to the amp tap multiplied by the CT primary rating.

### “GF CT”

CSH core balance CT rating or primary rated current of standard CT zero sequence CT. Parameter set during commissioning.

### “GF CT=PH CT”

Choice of GF CT used when DIP switch SW1 is set for ground fault determination by internal summation of phase currents. When selected, GF CT=PH CT automatically.

### “GF IP”

Ground fault protection instantaneous pickup.

### “GF ITD”

Ground fault protection instantaneous time delay.

### “GF TCC”

Ground fault time current characteristic or curve.

### “GF TD”

Ground fault protection time delay.

### “GND FAULT”

Message indicating ground fault protection operating (steady message) or tripped (blinking message).

### “inst.”

Instantaneous pickup time delay settings which correspond to tripping in about 25 ms.

### Internal Fault Indicator

LED indicator which lights up when the digital relay is unavailable due to initialization upon energizing, or due to an internal fault.

### “LATCH”

Parameter that defines the output contact operating mode.

“YES”: latching

“NO”: no latching.

### LTI

Long time inverse. Tripping curve equivalent to the VIT curve, set with long time delays (>3 s).

### meters

Button used for measurement reading.

### “off”

Setting which disables the corresponding protection.

### on

Green LED indicator showing that the digital relay is energized.

### P

Refers to parameter setup mode access hole on rear of digital relay.

### Phase Current Sensor Module

Connector used to connect the current inputs from the CT. Also referred to as the CCA 650.

### “PH CS”

Phase current setting. This is equal to the amp tap multiplied by the CT primary rating.

### “PH CT”

CT primary rated current. Parameter set during commissioning.

### “PHASE FAULT”

Message indicating 3-phase overcurrent protection operating (steady message) or tripped (blinking message).

### “PH IP”

Phase protection instantaneous pickup.

## GLOSSARY (cont.)

### "PH ITD"

Phase protection instantaneous time delay.

### "PH TCC"

Phase time current characteristic or curve.

### "PH TD"

Phase protection time delay.

### *reset*

Button used to acknowledge a protective system that has tripped.

### RI

Rapid inverse curve. Setting that is chosen for a rapid inverse curve.

### *settings*

Button used to read and set protection parameters.

### SIT

Standard inverse time. Setting that is chosen for an inverse time curve.

### SW1

Identification of DIP switches used to choose the ground fault current measurement method by summation of the three phase currents or by core balance CT. These switches are located on the rear of the digital relay.

### SW2

Identification of DIP switches used to choose the 1 A or 5 A CT secondary current rating for the digital relay.

### 3I

Abbreviation for ground fault measurement by internal summation of phase currents.

### "Tor 2A"

GF CT setting when using CSH 120 or CSH 200 for external ground fault sensing when  $0.1 A < GF IP < 20 A$ .

### "Tor30A"

GF CT setting when using CSH 120 or CSH 200 for external ground fault sensing when  $1.5 A < GF IP < 300 A$ .

### *trip*

Red LED indicator that shows that the relay has tripped.

### "TRIP"

Phase trip current. Replaces "TRIPa," "TRIPb," and "TRIPc" when the phase fault current magnitude exceeds  $24 \times PH CT$ .

### "TRIPa"

Phase A trip current.

### "TRIPb"

Phase B trip current.

### "TRIPc"

Phase C trip current.

### "TRIPg"

Zero sequence trip current.

### UIT

Ultra inverse time. Setting that is chosen for an ultra inverse time curve.

### *value +*

Button used to move upwards through the loop of possible settings towards higher values.

### *value -*

Button used to move downward through the loop of possible settings toward lower values.

### VIT

Very inverse time. Setting that is chosen for a very inverse time curve.

**APPENDIX C—COMMUNICATION CABLE PINOUTS**

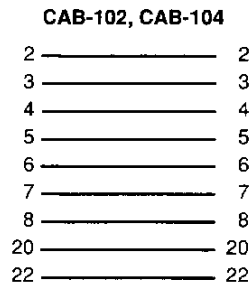
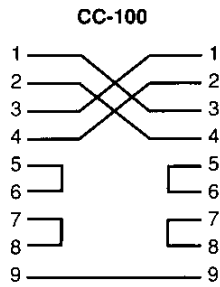
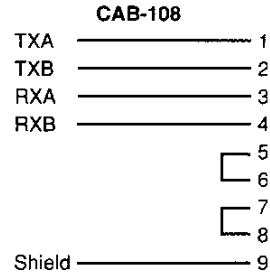
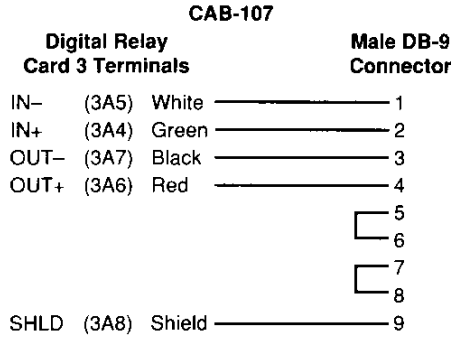

## APPENDIX D—CSH CORE BALANCE CTs

### OPERATION

Ground fault current can be measured externally by one of the following methods:

- By a CSH 120 or CSH 200 core balance CT. These two CTs differ only in diameter: the CSH 120 window diameter is 4.72" (120 mm), and the CSH 200 window diameter is 7.87" (200 mm). With this method, two input ratings are possible, according to digital relay connections:
  - use the 2 A rating if the ground fault instantaneous pickup setting is between 0.1 A and 20 A ("GF CT=Tor 2A")
  - use the 30 A rating if the ground fault instantaneous pickup setting is between 1.5 A and 300 A ("GF CT=Tor30A").
- By a 1 A or 5 A zero sequence CT if the expected ground current is higher than 300 A. (With this method, the digital relay requires the addition of a CSH 30 core balance CT, which acts as an intermediate CT.)
- By a CSH 30 core balance CT installed on the reverse current of the three phase CTs.

See page 79 for a summary of the various methods of ground fault current measurement.

### DIP SWITCH SETTINGS FOR CSH CORE BALANCE CTs

Before using the CSH core balance CT for external sensing of ground fault current, set the DIP switch SW1 as shown in figure 77.

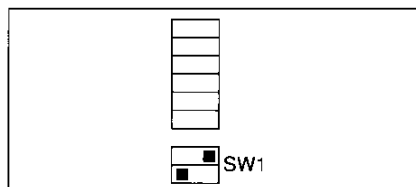

*Figure 77: SW1 setting for ground fault current measurement by external core balance CT*

### CSH CORE BALANCE CT CONNECTIONS (CSH 120, 200)

Using the CCA 606 connector, connect the CSH core balance CT to the digital relay as follows:

- For 2 A rating: connect to terminals 2A2 and 2A4 (figure 78).
- For 30 A rating: connect to terminals 2A3 and 2A4 (figure 79).

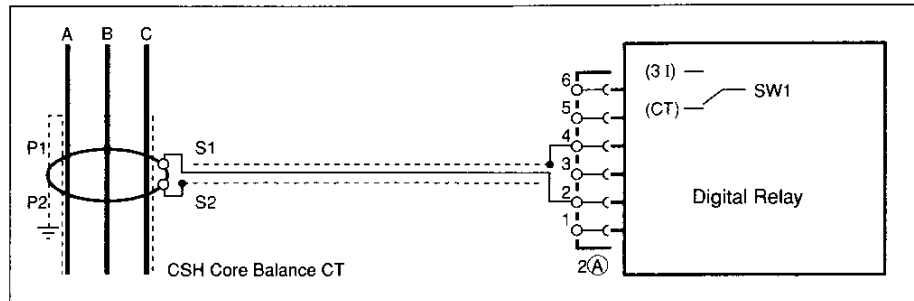

Figure 78: Connecting digital relay with a CSH core balance CT for the 2 A rating

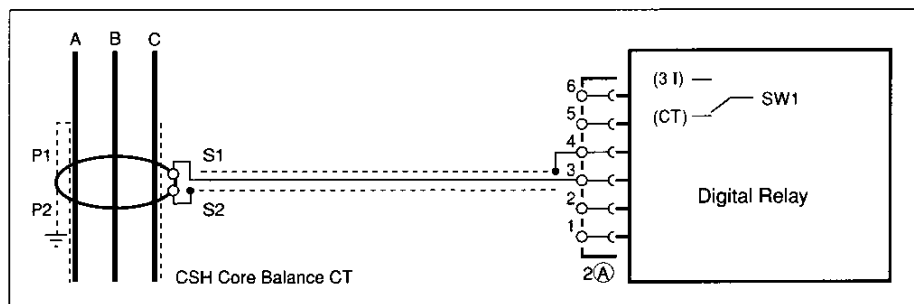

Figure 79: Connecting digital relay with a CSH core balance CT for the 30 A rating

Use cable with the following specifications:

- Type: shielded, sheathed
- Cross section: diameter  $\geq$ AWG 18 ( $\geq 0.93$  mm<sup>2</sup>)
- Resistance per unit length:  $< 100$  m $\Omega$ /m
- Minimum dielectric strength: 1000 V

**CONNECTING CORE  
 BALANCE CT TO  
 ZERO SEQUENCE  
 CURRENT INPUT**

This connection requires the use of the CSH 30 core balance CT, which acts as an interface between the standard zero sequence CT and the digital relay.

**! WARNING**

**HAZARD OF ELECTRIC SHOCK OR BURN.**

*Never connect the secondary of a standard 1 A or 5 A CT directly to the neutral/ground input terminals. Always use an interposing CSH 30 core balance CT to transform the secondary current of the zero sequence CT to the design input level. Failure to transform the secondary current will result in an open circuit of the CT secondary.*

Failure to follow this precaution could result in electric shock, severe personal injury, death, or equipment damage!

**Connecting the standard zero sequence CT to the CSH 30 core balance CT—** Connect the standard zero sequence CT to the CSH 30 core balance CT by winding the secondary lead of the standard CT onto the CSH 30 core balance CT. This cable, which runs from the S2 terminal of the standard CT, must enter the CSH 30 core balance CT through the side marked P2.

On the 1 A CT, pass the cable through and wrap it around the CT five times (figures 80, 81). On the 5 A CT, pass the cable through once (figures 82, 83).

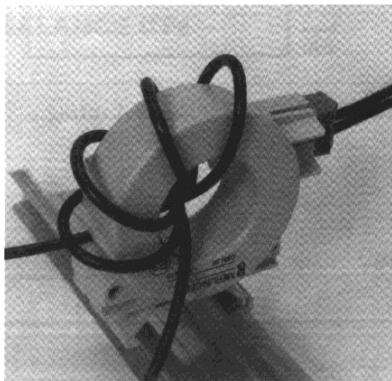

Figure 80: CSH 30 interposing CT with five turns of a 1 A secondary lead

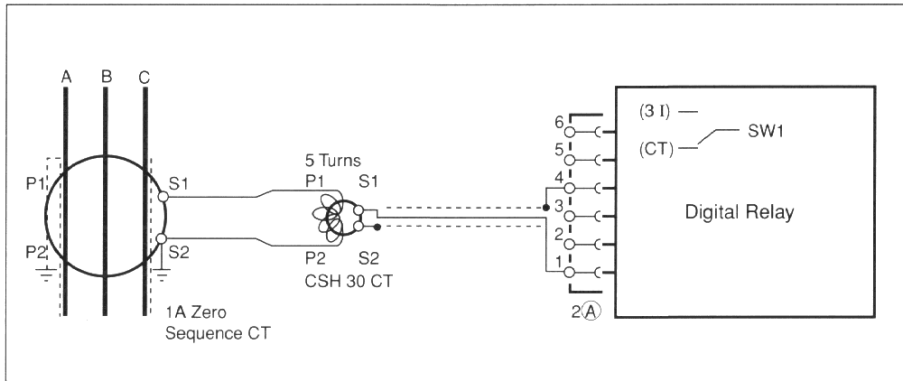

Figure 81: Digital relay connected to a standard 1 A zero sequence CT

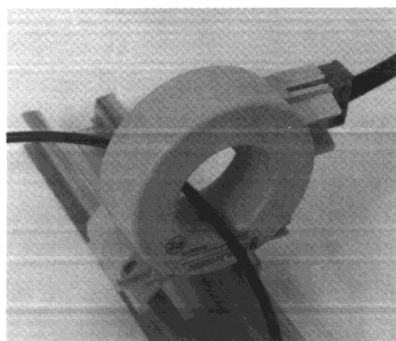

Figure 82: CSH 30 interposing CT with one turn of a 5 A secondary lead

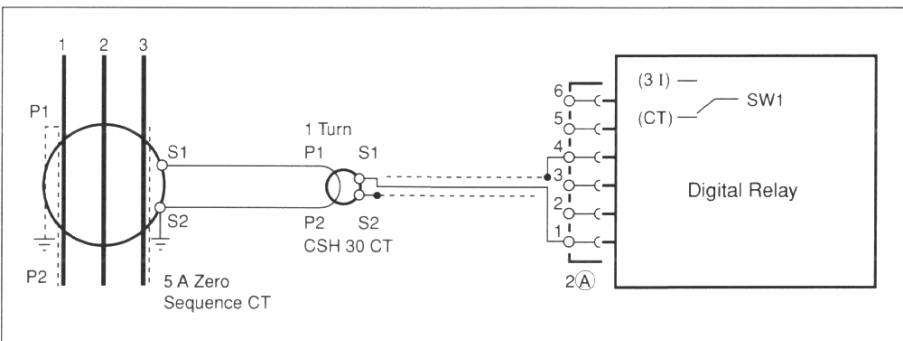

Figure 83: Digital relay connected to a standard 5 A zero sequence CT

## CONNECTING CORE BALANCE CT TO ZERO SEQUENCE CURRENT INPUT

Connecting The CSH 30 Core Balance CT To The Digital Relay—Using the CCA 606 connector (item 2A, figure 20, page 18), connect the CSH 30 core balance CT to the digital relay terminals 2A1 and 2A4.

Use cable with the following specifications:

- Type: shielded, sheathed
- Cross section: diameter  $\geq$ AWG 18 ( $\geq 0.93\text{mm}^2$ )
- Resistance per unit length:  $<100\text{m}\Omega/\text{m}$ .
- Dielectric test voltage:  $\geq 1000\text{ V}$  shielding/core and shielding/external frame
- Length: 6.6' (2 m) maximum

## CT ASSEMBLY MOUNTING

There are three basic locations for mounting the CT assembly:

- on the MV cable (CSH 120, CSH 200); see figure 84
- on a frame (CSH 30, CSH 120, CSH 200); see figure 85
- on the symmetric DIN rail (CSH 30, CSH 120), either vertically (figure 86) or horizontally (figure 87)

*Note: Do not mount the CT with conductive material (for example, stripped electric cable or metal wire); doing so could disturb CT operation. Use cable binding instead.*

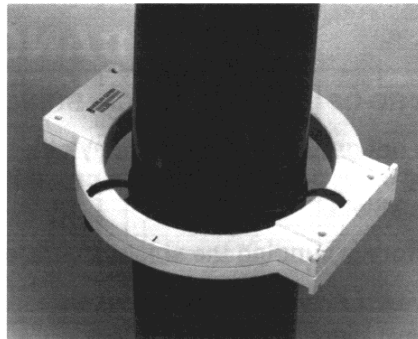

Figure 84: CT assembly mounted on MV cable

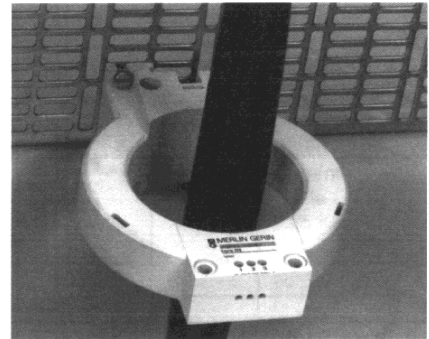

Figure 85: CT assembly mounted on frame

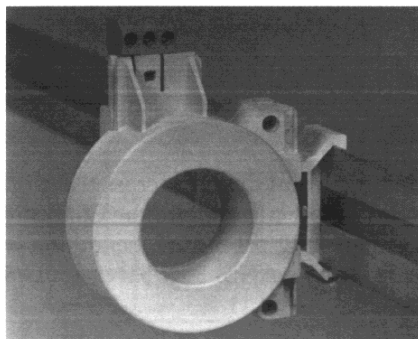

Figure 86: CT assembly mounted vertically on symmetric DIN rail

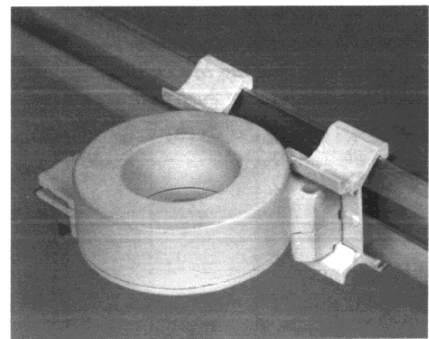

Figure 87: CT assembly mounted horizontally on symmetric DIN rail

## CABLING CONNECTIONS

### ⚠ DANGER

#### HAZARD OF ELECTRIC SHOCK, BURN, OR EXPLOSION.

- Only qualified electrical workers should install this equipment. Such work should be performed only after reading this entire set of instructions.
- Follow proper safety procedures regarding CT secondary wiring. *Never* open-circuit the secondary of a CT.
- To disconnect the current inputs with the power on, never disconnect the wires; unplug the phase current sensor module from the rear of the digital relay.

Failure to follow these precautions will result in electric shock, severe personal injury, or death!

To connect the cable, follow these steps:

1. Connect the cable shielding to terminal 2A4 using the shortest possible route.
2. Flatten the cable as much as possible against the metal cubicle frame.
3. The cable shielding is grounded in the digital relay. *Do not* ground the cable at any other point.

### ⚠ DANGER

#### HAZARD OF ELECTRIC SHOCK, BURN, OR EXPLOSION.

- Do not ground the cable at any other point. Grounding the shield at any other point may create a ground loop, causing high currents on the shield.
- Before grounding the shield, insulate the ungrounded end.

Failure to follow these precautions will result in electric shock, severe personal injury, or death!

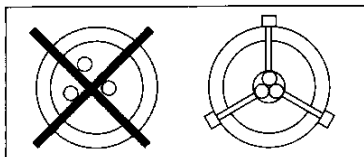

Figure 88: Incorrect and correct methods of grouping MV cables together in center of core balance CT

4. Group the MV cables together, and install them in the center of the core balance CT (figure 88). The MV cable shielding *must* pass through the CT to cancel out measurement of the eddy currents carried by the conductor.

*Note:* Cable length must not exceed 6.6' (2 m). This restriction applies only when the CSH 30 core balance CT is the interface between a standard CT and the digital relay.

## TESTING

Do not inject current directly across the ground fault terminals on the rear of the digital relay; inject current into the CSH core balance CT primary. Follow the ground fault testing procedure, beginning with **Testing**, page 62, and continuing through **Table 15—ANSI 50N/51N or 50G/51G Installation Characteristics**, page 64.

**APPENDIX E—GROUND FAULT CURRENT MEASUREMENT METHOD SUMMARY**

Table 18: Ground Fault Current Measurement Method Summary

Measurement Method	Setting Range	Core Bal. CT	Connections	SW1 Setting	GF CT Setting	Remark
Internal Phase Current Summation	0.05 PH CT to 10 PH CT	None			"PH CT"	Digital Relay Considers GF CT=PH CT
Specific CSH Core Balance CT On 2 A Input Rating	0.1 A to 20 A	CSH 120 CSH 200			"tor 2A" (2 A Core Bal. CT)	Digital Relay Considers GF CT=2 A
Specific CSH Core Balance CT On 30 A Input Rating	1.5 A to 300 A	CSH 120 CSH 200			"tor 30A" (30 A Core Bal. CT)	Digital Relay Considers GF CT=30 A
Standard 1 A CT	0.05 A to 10 GF CT	1 A CT + CSH 30 Core Balance CT as Interface			See table 14, page 61.	Primary Rated Current: 1 A to 6.25 kA
Standard 5 A CT	0.05 GF CT to 10 GF CT	5 A CT + CSH 30 Core Balance CT as Interface			See table 14, page 61.	Primary Rated Current: 1 A to 6.25 kA
Sum Of Phase CT Secondaries (1 A or 5 A)	0.05 PH CT to 10 PH CT	CSH 30 Core Balance CT as Interface			"PH CT"	Digital Relay Considers GF CT=PH CT

## APPENDIX F—DEFAULT SETTINGS

### Device Parameters

PH CT ..... 100 A  
GF CT ..... PH CT  
FREQ ..... 60 Hz  
LATCH ..... YES  
ADDR<sup>①</sup> ..... 1  
BAUD<sup>①</sup> ..... 9600

### Protection Settings

PH TCC ..... DT  
PH CS ..... off  
PH TD ..... 100 ms  
PH IP ..... off  
PH ITD ..... 50 ms

GF TCC ..... DT  
GF CS ..... off  
GF TD ..... 100 ms  
GF IP ..... off  
GF ITD ..... 50 ms

### Communications Card Settings

Ammeter Threshold Level ..... 2.00%  
Scale Factor A ..... 0  
Scale Factor C ..... 0

### DIP Switch Settings

See figures 15 and 18, page 16.

<sup>①</sup> For communicating models only.

## APPENDIX G—REAR COVER

For some installations, it may be necessary to cover the rear connections to guard against accidental damage to the connectors. In such cases, an optional rear cover (figure 89) can be installed after wiring is complete. Figure 90 shows digital relay dimensions (top view) with the cover installed. For ordering information, see Appendix H—Ordering Information, page 82.

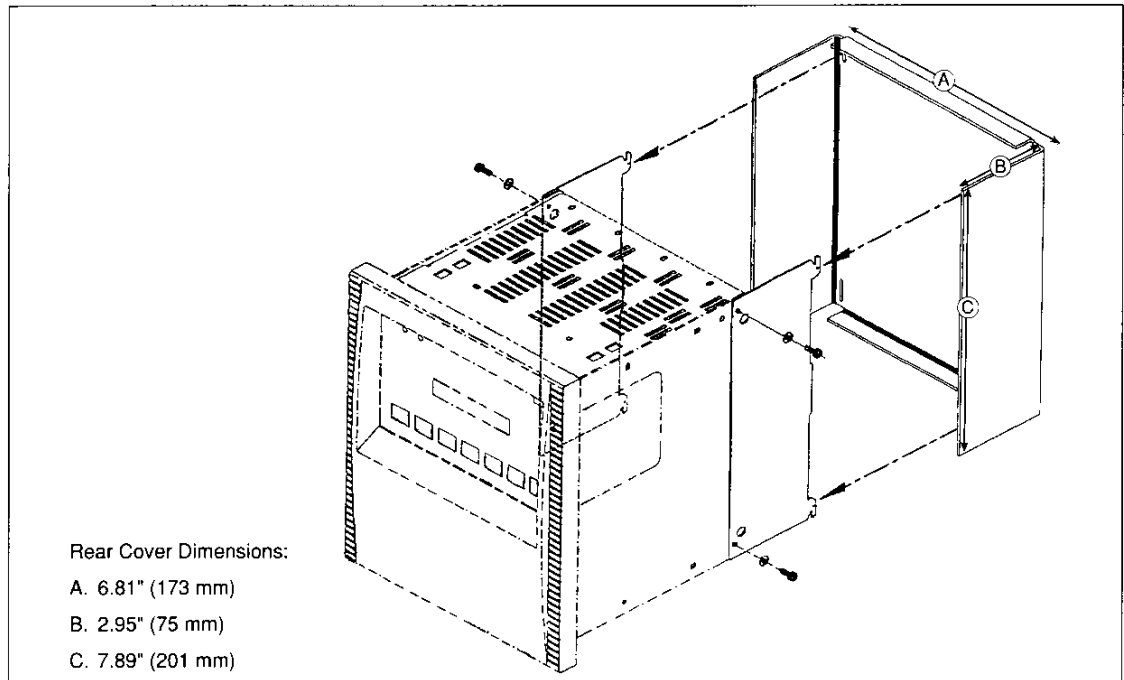

Figure 89: Optional rear cover

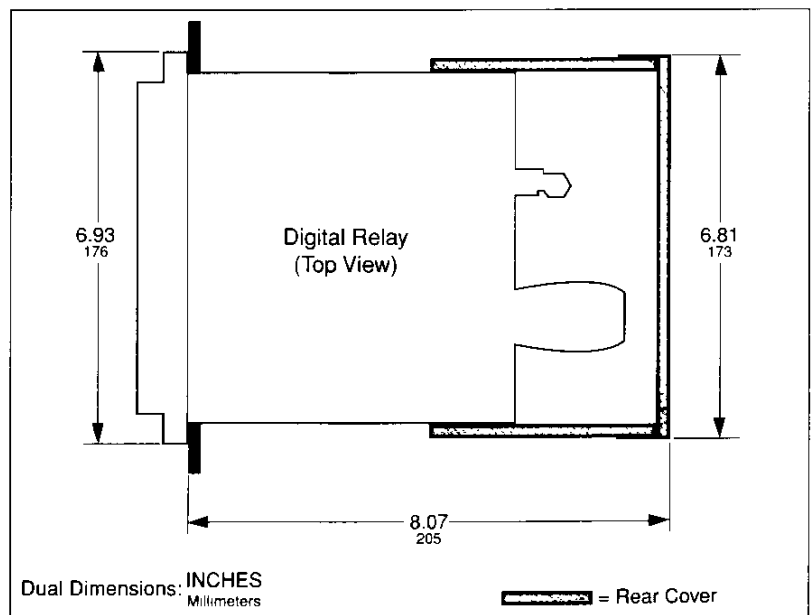

Figure 90: Digital relay dimensions with rear cover installed

## APPENDIX H—ORDERING INFORMATION

Table 19 below lists accessories available for the digital relay.

**Table 19**  
**Digital Relay Accessories**

Description	Part Number
CAB-107 Cable	3090CAB107
CSH 30 Core Balance CT	CSH 30
CSH 120 Core Balance CT	CSH 120
CSH 200 Core Balance CT	CSH 200
Multipoint Communications Adapter	3090MCA485
Multipoint Communications Terminator	3090MCT485
Rear Cover	AMT 813

### Ordering Instructions

When ordering accessories, provide the following information:

- digital relay model number
- part number of each part being ordered
- description of each part being ordered
- quantity

## APPENDIX I—SETTING SCALE FACTORS FOR EXTENDED METERING RANGES

The digital relay stores instantaneous metering data in single registers. Each register has a maximum range of 32,767. In order to meter currents above 3200 A, the digital relay can accommodate a register multiplier of 10.

The digital relay stores this multiplier as a scale factor. A scale factor is the multiplier expressed as a power of 10. For example, a multiplier of 10 is represented as a scale factor of 1, since  $10^1=10$ .

The digital relay displays (via communications) "32767" for any reading where the scale factor should be changed to bring the reading back into range. For example, since a digital relay register cannot store a number as large as 35,000, a 35,000 A current requires a multiplier of 10. Therefore, 35,000 will be converted to  $3,500 \times 10$ . The digital relay stores this value as 3,500 with a scale factor of 1 (since  $10^1=10$ ).

Scale factors are arranged in scale groups. The abbreviated register list in **Appendix J**, page 85, shows the scale group associated with each metered value.

The command interface can be used to change scale factors on a group of metered values. The procedure below tells how.

*Note: When implementing software to read digital relay data over the communications link, you must account for these scale factors. To correctly read any metered value with a scale factor other than 0, you must multiply the register value read by its multiplier.*

*When you change a scale factor, all min/max values are reset.*

To change scale factors, do the following:

1. Determine the required scale factors

There are three user-defined scale groups. The desired scale factor for each group must be determined. Table 20 below lists the available scale factors for each of the three scale groups. The factory default for each scale group is 0. If you need either an extended range or more resolution, select any of the available scale factors to suit your need.

*Note: Scale group B is not applicable for the digital relay.*

**Table 20: Available Scale Factors**

Scale Group/Amperes	Scale Factor
Scale Group A—Phase Current Amperes 0–32767 A 0–327.67 kA	0 (default) 1
Scale Group B—N/A	—
Scale Group C—Ground Current Amperes 0–32767 A 0–327.67 kA	0 (default) 1

**Setting Scale Factors for  
Extended Metering Ranges  
(cont.)**

2. Using POWERLOGIC Application Software, read the existing scale factors from registers 2020–2022 and write them down.  
Register 2020    Scale Group A  
Register 2021    Scale Group B  
Register 2022    Scale Group C
3. Make note of the changes required to the scale groups.
4. Write the appropriate values to a series of command parameter registers, one for each scale group. Refer to table 21 below.

**Table 21: Scale Factor Values**

Reg. No.	Value	Description
7700	2110	Command code to change scale factors. (Min/max will be reset.)
7701–7703	Scale Factors	Scale Group A—write to reg. 7701 Scale Group B—write to reg. 7702 ① Scale Group C—write to reg. 7703
<b>Scale Group</b>		
Scale Group A: Ammeter Per Phase		0=multiplier of 1.00 (default) 1=multiplier of 10.0
Scale Group B: N/A		—
Scale Group C: Ammeter Ground		0 =multiplier of 1.00 (default) 1 =multiplier of 10.0

① Not applicable.

5. Write a command code (2110) to the digital relay's command interface register (7700).

## APPENDIX J—ABBREVIATED REGISTER LISTING

This appendix offers an abbreviated listing of the digital relay registers. This list pertains only to the communicating models (DR-LXS01 50A TBN, DR-LXS01 50A TEN) of the digital relay.

The communicating versions of the digital relay use two separate microprocessors. One microprocessor controls the protective features and some metering features of the digital relay. The other microprocessor, located on the communications card, controls other metering functions, stores history and trip information, and indicates status of protection by register 3020 (see page 88). This dual microprocessor scheme is illustrated below (figure 91).

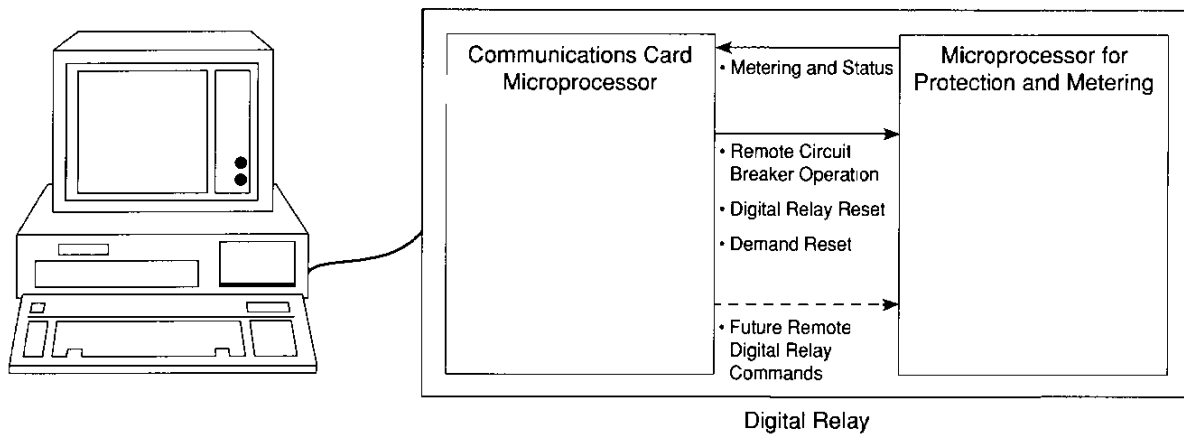

Figure 91: Dual microprocessor scheme (communicating digital relays)

Reg. No.	Register Name	Units	Range
<b>Instantaneous</b>			
1003	Current—phase A	Amperes/scale factor A	0 to 32,767
1004	Current—phase B	Amperes/scale factor A	0 to 32,767
1005	Current—phase C	Amperes/scale factor A	0 to 32,767
1007	Current—ground	Amperes/scale factor C	0 to 32,767
1008	Current—3-phase average	Amperes/scale factor A	0 to 32,767
<b>Minimums</b>			
1203	Minimum current—phase A	Amperes/scale factor A	0 to 32,767
1204	Minimum current—phase B	Amperes/scale factor A	0 to 32,767
1205	Minimum current—phase C	Amperes/scale factor A	0 to 32,767
1207	Minimum current—ground	Amperes/scale factor C	0 to 32,767
1208	Minimum current—3-phase average	Amperes/scale factor A	0 to 32,767
<b>Maximums</b>			
1403	Maximum current—phase A	Amperes/scale factor A	0 to 32,767
1404	Maximum current—phase B	Amperes/scale factor A	0 to 32,767
1405	Maximum current—phase C	Amperes/scale factor A	0 to 32,767
1407	Maximum current ground	Amperes/scale factor C	0 to 32,767
1408	Maximum current—3-phase average	Amperes/scale factor A	0 to 32,767
<b>Current Demand</b>			
1700	Present thermal current demand—3-phase average	Amperes/scale factor A	0 to 32,767
1701	Present thermal current demand—phase A	Amperes/scale factor A	0 to 32,767
1702	Present thermal current demand—phase B	Amperes/scale factor A	0 to 32,767
1703	Present thermal current demand—phase C	Amperes/scale factor A	0 to 32,767
1708	Peak thermal current demand—3-phase average	Amperes/scale factor A	0 to 32,767
1709	Peak thermal current demand—phase A	Amperes/scale factor A	0 to 32,767
1710	Peak thermal current demand—phase B	Amperes/scale factor A	0 to 32,767
1711	Peak thermal current demand—phase C	Amperes/scale factor A	0 to 32,767
<b>Date/Time</b>			
<i>Note: The date and time in registers 1800–1802 are stored as follows (other dates and times are stored in an identical manner):</i>			
<i>Register 1800: Month (byte 1)=1–12; Day (byte 2)=1–31</i>			
<i>Register 1801: Year (byte 1)=0–199; Hour (byte 2)=0–23</i>			
<i>Register 1802: Minute (byte)=0–59; Seconds (byte)=0–59</i>			
<i>The year is zero, based on the year 1900 in anticipation of the 21st century (e.g., 1989 is represented as 89, and 2009 is represented as 109).</i>			
1800–1802	Date/time of last restart	Month, day, year, hour, minute, second	*See note above
1803–1805	Date/time of peak demand—phase A current	Month, day, year, hour, minute, second	Same as registers 1800–1802
1806–1808	Date/time of peak demand—phase B current	Month, day, year, hour, minute, second	Same as registers 1800–1802
1809–1811	Date/time of peak demand—phase C current	Month, day, year, hour, minute, second	Same as registers 1800–1802
1815–1817	Date/time of last reset of peak demand current	Month, day, year, hour, minute, second	Same as registers 1800–1802
1818–1820	Date/time of last clear of min./max. inst. values	Month, day, year, hour, minute, second	Same as registers 1800–1802
1830–1832	Date/time of last control power failure	Month, day, year, hour, minute, second	Same as registers 1800–1802
1842–1844	Present/set date/time	Month, day, year, hour, minute, second	Same as registers 1800–1802

Reg. No.	Register Name	Units	Range	Register Description
<b>Housekeeping</b>				
2016	Nominal system frequency	Hz	50 or 60	
2017	Digital relay address	None	0–199	
2018	Digital relay baud rate	Baud	1200, 2400, 4800, 9600, 19200	
2020	Scale group A: ammeter per phase	None	0 to 1	
2022	Scale group C: ammeter ground	None	0 to 1	
2028	Password	None	0 to ±32,767	
2040–2041	Relay label	ASCII	Any valid alphanumeric	
2042–2049	Relay nameplate	ASCII	Any valid alphanumeric	
2085	Square D product ID number	None	480	
2093	Software revision sublevel	None	0 to 9999	
2094	Software revision level	None	01:00 to 99:99	
2096–2097	Unit serial number	None	0 to 2147483647 (7FFFFFFF hex)	
2120	Bit map for self test results of POWERLOGIC comm. card (self-tests performed on power-up and/or restart)	None	0 to 044AB (hex)	Bit 0=ls set to "1" if any error occurs Bit 1=real time clock failure Bit 2 is reserved Bit 3=8031 RAM memory failure Bit 4 is reserved Bit 5=comms card EEPROM memory failure Bit 6 is reserved Bit 7=comms UART failure Bit 8 is reserved Bit 9 is reserved Bit 10=serial EEPROM failure Bits 11–13 are reserved Bit 14=boot/download monitor active Bit 15 is reserved
2400	Input status	None	0 or 1	Bit Map indicating the state of the input. 1=ON and 0=OFF. Bit 0 represents input 1.
2402–2403	Input 1 label	None	Alphanumeric 4 characters	Label for input 1
2404	High byte input 1 count	Counts	0 to 9,999	Where reg. 2404 is the high byte and reg. 2405 is the low byte. To determine total count of input 1 transition, multiply value in reg. 2404 by 10,000 and add the value in reg. 2405.
2405	Low byte input 1 count	Counts	0 to 9,999	Where reg. 2404 is the high byte and reg. 2405 is the low byte. To determine total count of input 1 transition, multiply value in reg. 2404 by 10,000 and add the value in reg. 2405.
2406	Total ON time, Input 1	Seconds	0 to 32,767	Represents the total time in seconds that input 1 has been in the ON state.

Reg. No.	Register Name	Units	Range	Register Description
<b>Trip Unit Functions—Instantaneous</b>				
3020	General status	None	0 to FE7F (Hex)	The general relay status. Bit 0=1 if any other bit is set Bit 1=1=relay is tripped Bit 2=1=last trip data is invalid Bit 3=1=relay is in parameter setup mode (1) Bit 4=1=settings verification required Bits 7, 6, 5=cause of trip: 000 -> relay reset; 001 -> phase protection; 010 -> ground fault protection; 011 -> phase & ground fault protection Bit 8 is reserved Bit 9=1=trip is latched (1) Bit 10=communications card jumper B enabled Bit 11=communications card jumper A enabled Bit 12 is reserved Bit 13 is reserved Bit 14 is reserved Bit 15=PROTECTION MICROPROCESSOR communications are offline. Register 3020 bits 1-8 invalid. Relay may be out of service, therefore no protection
3021	Instantaneous pickup status	None	0 to 803E (Hex)	The relevant bits in this unit indicate if the relay is exceeding one or more protection pickup. Status of trip: Bit 0 is reserved Bit 1=relay is in pickup Bit 2=phase protection instantaneous pickup Bit 3=phase protection time overcurrent pickup Bit 4=ground fault protection instantaneous pickup Bit 5=ground fault protection time overcurrent pickup Bits 6-14 are reserved Bit 15=register data is invalid

Reg. No.	Register Name	Units	Range
<b>Pickup History</b>			
3022-3024	Date/time of last phase instantaneous pickup	Month, day, year, hour, minute, second	Same as registers 1800-1802
3025-3027	Date/time of last phase time overcurrent pickup	Month, day, year, hour, minute, second	Same as registers 1800-1802
3028-3030	Date/time of last ground fault instantaneous pickup	Month, day, year, hour, minute, second	Same as registers 1800-1802
3031-3033	Date/time of last ground fault time overcurrent pickup	Month, day, year, hour, minute, second	Same as registers 1800-1802
3034-3039	Reserved for future use		

Reg. No.	Register Name	Units	Range
<b>Block Peak Demand (from front panel)</b>			
3040	5-minute block interval peak demand current—phase A (displayed by front panel)	Amperes/scale factor A	0-32,767
3041	5-minute block interval peak demand current—phase B (displayed by front panel)	Amperes/scale factor A	0-32,767
3042	5-minute block interval peak demand current—phase C (displayed by front panel)	Amperes/scale factor A	0-32,767

Appendix J—Abbreviated Register Listing

Reg. No.	Register Name	Units	Range	Register Description
<b>Trip Information</b>				
3101	Cause of most recent trip	None	0 to 3E, 8000 (hex)	The bits in this register are updated upon each trip. Cause of trip: Bit 0 is reserved Bit 1=1; indicates valid trip data Bit 2=phase protection instantaneous trip Bit 3=phase protection time overcurrent trip Bit 4=ground fault protection instantaneous trip Bit 5=ground fault protection time overcurrent trip Bits 6–14 are reserved Bit 15=register data is invalid
3102	Pickup status at time of most recent trip	None	0 to 3E, 8000 (hex)	The bits in this register indicate the relay protection settings exceeded at time of the most recent trip. Bit 0 is reserved Bit 1=1; indicates valid pickup data Bit 2=phase protection instantaneous pickup Bit 3=phase protection time overcurrent pickup Bit 4=ground fault protection instantaneous pickup Bit 5=ground fault protection time overcurrent pickup Bits 6–14 are reserved Bit 15=register data is invalid
3103–3105	Date and time of most recent trip	Month, day, year, hour, minute, second	Same as registers 1800–1802	
3106	Most recent trip current—phase A	Deka Amperes	0 to 32,767	
3107	Most recent trip current—phase B	Deka Amperes	0 to 32,767	
3108	Most recent trip current—phase C	Deka Amperes	0 to 32,767	
3109	Reserved			
3110	Most recent trip current—ground	Deka Amperes	0 to 32,767	
3111	Most recent trip current—3-phase average	Deka Amperes	0 to 32,767	
3112–3124	Reserved			
3125	Thermal demand current—3-phase average at most recent trip	Amperes/ scale factor A	0 to 32,767	
3126	Demand current—phase A at most recent trip	Amperes/ scale factor A	0 to 32,767	
3127	Demand current—phase B at most recent trip	Amperes/ scale factor A	0 to 32,767	
3128	Demand current—phase C at most recent trip	Amperes/ scale factor A	0 to 32,767	
3129	Reserved			
3130–3135	Date/time of most recent trip 6-reg format	Second, minute, hour, day, month, year	See note 3	
3136–3139	Reserved			

Reg. No.	Register Name	Units	Range	Register Description
<b>Trip Information</b>				
3140	Cause of 2nd most recent trip	None	0 to 3E, 8000 (hex)	The bits in this register are updated upon each trip. Cause of trip: Bit 0 is reserved Bit 1=1; indicates valid trip data Bit 2=phase protection instantaneous trip Bit 3=phase protection time overcurrent trip Bit 4=ground fault protection instantaneous trip Bit 5=ground fault protection time overcurrent trip Bits 6–14 are reserved Bit 15=register data is invalid
3141	Pickup status at time of 2nd most recent trip	None	0 to 3E, 8000 (hex)	The bits in this register indicate the relay protection settings exceeded at the time of the second most recent trip. Bit 0 is reserved Bit 1=1; indicates valid pickup data Bit 2=phase protection instantaneous pickup Bit 3=phase protection time overcurrent pickup Bit 4=ground fault protection instantaneous pickup Bit 5=ground fault protection time overcurrent pickup Bits 6–14 are reserved Bit 15=register data is invalid

Reg. No.	Register Name	Units	Range
3142–3144	Date and time of 2nd most recent trip	Month, day, year, hour, minute, second	Same as registers 1800–1802
3145	2nd most recent trip current—phase A	Deka Amperes	0 to 32,767
3146	2nd most recent trip current—phase B	Deka Amperes	0 to 32,767
3147	2nd most recent trip current—phase C	Deka Amperes	0 to 32,767
3148	Reserved		
3149	2nd most recent trip current—ground	Deka Amperes	0 to 32,767
3150	2nd most recent trip current—3-phase average	Deka Amperes	0 to 32,767
3151–3163	Reserved		
3164	Thermal demand current—3-phase average at 2nd most recent trip	Amperes/scale factor A	0 to 32,767
3165	Thermal demand current—phase A at 2nd most recent trip	Amperes/scale factor A	0 to 32,767
3166	Thermal demand current—phase B at 2nd most recent trip	Amperes/scale factor A	0 to 32,767
3167	Thermal demand current—phase C at 2nd most recent trip	Amperes/scale factor A	0 to 32,767
3168–3169	Reserved		

Appendix J—Abbreviated Register Listing

Reg. No.	Register Name	Units	Range	Register Description
<b>Trip Information</b>				
3170	Cause of 3rd most recent trip	None	0 to 3E, 8000 (hex)	The bits in this register are updated upon each trip. Cause of trip: Bit 0 is reserved Bit 1=1; indicates valid trip data Bit 2=phase protection instantaneous trip Bit 3=phase protection time overcurrent trip Bit 4=ground fault protection instantaneous trip Bit 5=ground fault protection time overcurrent trip Bits 6–14 are reserved Bit 15=register data is invalid
3171	Pickup status at time of 3rd most recent trip	None	0 to 3E, 8000 (hex)	The bits in this register indicate that the relay protection settings exceeded at the time of the third most recent trip. Bit 0 is reserved Bit 1=1; indicates valid pickup data Bit 2=phase protection instantaneous pickup Bit 3=phase protection time overcurrent pickup Bit 4=ground fault protection instantaneous pickup Bit 5=ground fault protection time overcurrent pickup Bits 6–14 are reserved Bit 15=register data is invalid

Reg. No.	Register Name	Units	Range
3172–3174	Date and time of 3rd most recent trip	Month, day, year, hour, minute, second	Same as registers 1800–1802
3175	3rd most recent trip current— phase A	Deka Amperes	0 to 32,767
3176	3rd most recent trip current—phase B	Deka Amperes	0 to 32,767
3177	3rd most recent trip current—phase C	Deka Amperes	0 to 32,767
3178	Reserved		
3179	3rd most recent trip current—ground	Deka Amperes	0 to 32,767
3180	3rd most recent trip current—3-phase average	Deka Amperes	0 to 32,767
3181–3193	Reserved		
3194	Thermal demand current—3-phase average at 3rd most recent trip	Amperes/scale factor A	0 to 32,767
3195	Thermal demand current—phase A at 3rd most recent trip	Amperes/scale factor A	0 to 32,767
3196	Thermal demand current—phase B at 3rd most recent trip	Amperes/scale factor A	0 to 32,767
3197	Thermal demand current—phase C at 3rd most recent trip	Amperes/scale factor A	0 to 32,767
3198–3199	Reserved		

Reg. No.	Register Name	Units	Range
<b>Digital Relay Settings Information</b>			
3220	Phase CT primary rating (PH CT)	Amperes	10 to 6,250
3221	Ground CT primary rating (GF CT)	Amperes	-30 (30 A CSH sensor); -2 (2 A CSH sensor); 0 (GFCT=PHCT); 1 to 6,250
3222	Phase current setting divided by the phase CT primary rating (PH CS/PH CT)	%	-1 (protection off); 30 to 800 (DT); 30 to 240 (other)
3223	Phase instantaneous pickup divided by the phase CT primary rating (PH IP/PH CT)	%	-1 (protection off); 100 to 2400
3224	Ground fault current setting divided by the ground CT primary rating (GF CS/GF CT)	%	-1 (protection off); 5 to 200 (TCC=DT); 5 to 100 (other)
3225	Ground fault instantaneous pickup divided by the ground CT primary rating (GF IP/GF CT)	%	-1 (protection off); 5 to 1000
3226	Phase time overcurrent time delay (PH TD)	Seconds/100	10 to 9,000 (DT); 10 to 1,250 (other)
3227	Phase instantaneous pickup time delay (PH ITD)	Seconds/100	0 to 200
3228	Ground fault time overcurrent time delay (GF TD )	Seconds/100	10 to 9,000 (DT); 10 to 1,250 (other)
3229	Ground fault instantaneous pickup time delay (GF ITD)	Seconds/100	0 to 200

Reg. No.	Register Name	Units	Range	Register Description
3230	Phase current setting (PH CS)	Amperes/PH CS Scale factor	3 to 32,767 (-1=off)	Phase current setting
3231	PH CS scale factor (for reg. 3230 only)	None	0 or 1	Phase current setting scale factor 0=scale by 1.00 ( <b>default</b> ) 1=scale by 10.0
3232	Phase instantaneous pickup (PH IP)	Amperes/PH IP Scale factor	10 to 32,767 (-1=off)	Phase instantaneous pickup

Appendix J—Abbreviated Register Listing

Reg. No.	Register Name	Units	Range	Register Description
3233	PH IP scale factor (for reg. 3232 only)	None	0 or 1	Phase instantaneous pickup scale factor 0=scale by 1.00 ( <b>default</b> ) 1=scale by 10.0
3234	Ground fault current setting (GF CS)	Amperes/GF CS Scale factor	1 to 15,000 (-1=off)	Ground fault current setting
3235	GF CS scale factor (for reg. 3234 only)	None	-2 or 0	Ground fault current setting scale factor -2=scale by 0.01 0=scale by 1.00 ( <b>default</b> )
3236	Ground fault instantaneous pickup (GF IP)	Amperes/GF IP Scale factor	1 to 32,767 (-1=off)	Ground fault instantaneous pickup
3237	GF IP scale factor (for reg. 3236 only)	None	-2, 0, or 1	Ground fault instantaneous scale factor -2=scale by 0.01 0=scale by 1.00 ( <b>default</b> ) 1=scale by 10.0
3238-3239	Phase time current curve (PH TCC)	ASCII string (1 or 2 leading spaces)	'_DT', '_SIT', '_VIT', '_EIT', '_UIT', '_RI'	Phase protection curve type <b>Note:</b> '_' denotes ASCII space, i.e., 20H
3240-3241	Ground fault time current curve (GF TCC)	ASCII string (1 or 2 leading spaces)	'_DT', '_SIT', '_VIT', '_EIT', '_UIT', '_RI'	Ground protection curve type <b>Note:</b> '_' denotes ASCII space, i.e., 20H
3242-3249	Reserved			
3250	Ammeter threshold level	Percent in 100ths	0 to 500	Ammeter threshold level. The value in this register represents a percentage of the phase sensor rating. This is a user-defined value in the range of 0 to 500 (0.00% to 5.00% of sensor rating). The default value is 200 (2.00%). Current readings that fall below the threshold level are returned to the corresponding register(s) as 0 amperes. <b>Note:</b> The setting of this threshold only affects metered values reported to SY/MAX registers (that is, it does NOT affect metered values as reported to the digital relay front panel).

Operational History

3320	Total relay operations over the life of the digital relay	None	0 to 32,767
3321	Relay operations since last soft reset of the digital relay	None	0 to 32,767
3322	Total trips since last counter reset	None	0 to 32,767
3323	Number of phase time overcurrent trips since last counter reset	None	0 to 32,767
3324	Number of phase instantaneous overcurrent trips since last counter reset	None	0 to 32,767
3325	Number of ground fault time overcurrent trips since last counter reset	None	0 to 32,767
3326	Number of ground fault instantaneous overcurrent trips since last counter reset	None	0 to 32,767
3327	Number of resets of relay output contacts over communications	None	0 to 32,767
3328	Number of relay open commands sent over communications	None	0 to 32,767

<b>Reg. No.</b>	<b>Register Name</b>	<b>Type</b>	<b>Range</b>
<b>Operational History</b>			
3329-3331	Date/time of last reset of trip counter	Month, day, year, hour, minute, second	See note 2
3332-3334	Date/time of last relay operation	Month, day, year, hour, minute, second	See note 2
3335-3337	Date/time of most recent relay reset over comms	Month, day, year, hour, minute, second	See note 2
3338-3340	Date/time of 2nd most recent relay reset over comms	Month, day, year, hour, minute, second	See note 2
3341-3343	Date/time of 3rd most recent relay reset over comms	Month, day, year, hour, minute, second	See note 2
3344-3346	Date/time of most recent open command over comms	Month, day, year, hour, minute, second	See note 2
3347-3349	Date/time of 2nd most recent open command over comms	Month, day, year, hour, minute, second	See note 2
3350-3352	Date/time of 3rd most recent open command over comms	Month, day, year, hour, minute, second	See note 2
3353-3355	Reserved		

<b>Reg. No.</b>	<b>Register Name</b>	<b>Units</b>	<b>Range</b>	<b>Register Description</b>
<b>Digital Relay UTA Diagnostics</b>				
3401	Reserved			
3402-3403	Reserved			
3404	Reserved			
3405	Reserved			
3406	Relay comms failure	Seconds	0 to 32,767 (no rollover)	The time since the POWERLOGIC comm. card received good data from protection microprocessor. Non-zero value indicates that communications are bad; zero means communications are good. The count begins 5 seconds after the last valid communication with protection microprocessor.
3407	Reserved			
3408	Reserved			
3409	Reserved			
3410	Reserved			
3411	Reserved			
4000-4056	Reserved			
4057-4099	Reserved			
4100-4165	Reserved			
4166-4199	Reserved			
4200-4204	Reserved			
4205-4249	Reserved			
4250-4261	Reserved			
4262-4299	Reserved			

Reg. No.	Register Name
4300–4340	Reserved
4341–4399	Reserved
4400–4484	Reserved
4485–4499	Reserved
4500–4524	Reserved
4525–4549	Reserved
4550–4573	Reserved
4574–4599	Reserved
4600–4630	Reserved
4631–4699	Reserved
4700–4739	Reserved
4740–4799	Reserved
4800–4819	Reserved

## Notes:

1. All values to be updated at least once each second unless otherwise noted.
2. Register 1800, Month (high byte)=1–12; Day (low byte)=1–31; Register 1801, Year (high byte)=1–199; Hour (low byte)=0–23; Register 1802, Minutes (high byte)=0–59; Seconds (low byte)=0–59. The year counter begins with 1900, therefore register 1801 high byte would be 0 for the year 1900, 1 for 1901, and so forth.
3. Seconds (register 700)=0–59; Minutes (register 701)=0–59; Hours (register 702)=0–23; Day (register 703) 1–31; Month (register 704)=1–12; Year (register 705)=1900–2099. The date and time are mapped from registers 1800–1802.
4. If communications with the relay are lost, all meter and trip values are set to -32,768 to indicate values are invalid.
5. Where a scale factor is indicated, the range of readings shown is the base range. The base range will be multiplied by the scale factor to provide the actual reading. The full range of actual reading is therefore dependent on the range that the scale factor can take.
6. All times and dates are from clock on communications card.
7. The following commands affect the communications card only and are not passed to the relay:
  - Set system time
  - Reset min/max currents
  - Reset all trip counters except total lifetime operations

## APPENDIX K—COMMAND INTERFACE

### INTRODUCTION

The digital relay provides a command interface that can be used to perform various remote operations such as relay reset, circuit breaker operation, and demand reset.

### COMMUNICATION CARD JUMPERS

As a security measure, all communicating versions of the digital relay are equipped with two removable jumpers located on the communications card (figure 92 below). Both jumpers are in place as the factory default.

Jumper B (figure 92) enables the ability to operate the circuit breaker, reset the relay, and reset the demand from a remote PC. If this jumper is removed, all remote PC access is lost. Jumper A (figure 92) is reserved for the enabling of other future relay commands. If this jumper is removed, all future remote relay commands will be disabled.

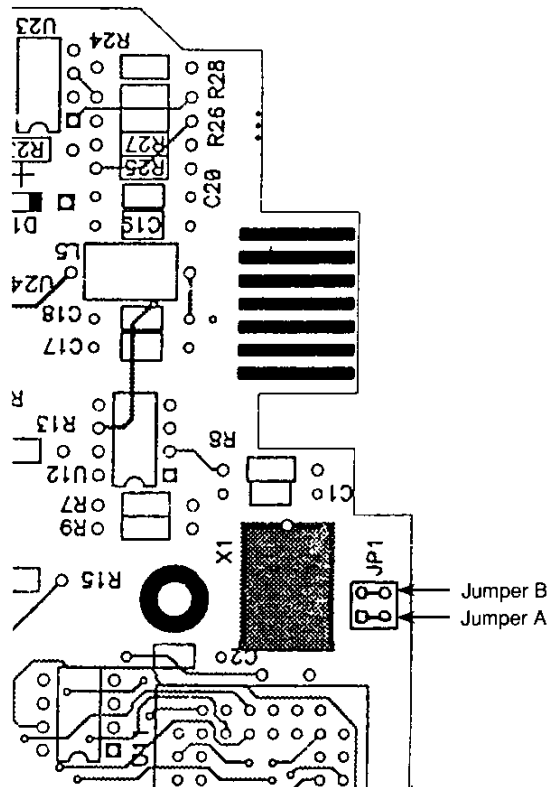

Figure 92: Communications card jumpers

**COMMUNICATION CARD  
JUMPERS (cont.)**

Figure 93 below illustrates possible jumper combinations and the features they support.

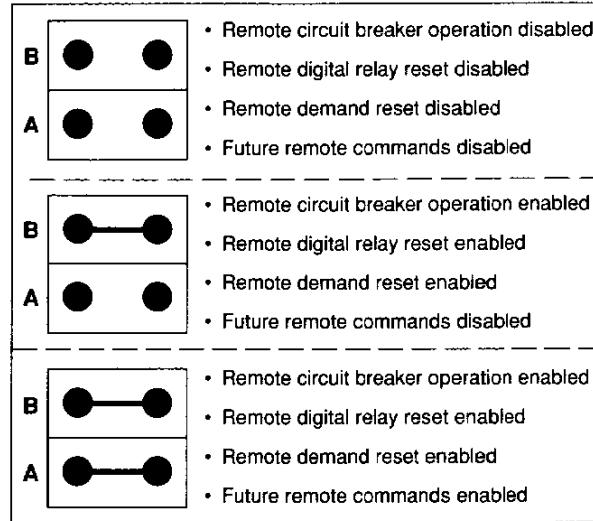

Figure 93: Possible jumper combinations and features supported

To use the command interface, do the following:

1. Referring to table 21 below, write the related parameter(s) to the command parameter registers (7701–7709). (Some commands require no parameter. For these commands, write the command code only to register 7700.)
2. Write a command code to the digital relay command interface register (7700).

*Note: For password-protected commands, the current password is stored in register 2028. (The password automatically changes any time the digital relay is reset.)*

**COMMAND CODES**

Table 22 below lists command codes that can be written to the command interface register (7700) and to the command interface parameter registers (7701–7709).

Table 22: Command Codes

Command	Parameter	Description	Reset Req'd.
1110	None	Soft reset of the unit	N
1130	Password (reg. 2028)	Reset trip condition (i.e., reset relay)	N
1220	None	Clear the trip counter	N
1310	Date/Time 6-register format	Set system date/time, 6-register format	N
1311	Date/Time 3-register format	Set system date/time, 3-register format	N
2110	Scale Factors A–C	Change scale factor, and reset min/max values and unit	N
2330	None	Enable unit 01's response to the SY/MAX enquire transmission (default)	N
2331	None	Disable unit 01's response to the SY/MAX enquire transmission	N
3350	Password (reg. 2028)	Open circuit breaker/switchgear	N
4110	None	Reset Min/Max	N
5110	None	Reset Peak Demand Currents	N

**COMMAND RESULT CODES** Table 23 below shows command result codes and corresponding command result conditions.

**Table 23: Command Result Codes**

Result Condition	Result Code (Hex)
Successful Commands	00
Undefined Commands	81
Commands with Undefined or Illegal Parameters	82
Time-out, Operation Not Performed	201
Invalid Password, Operation Not Performed	202

*Note: Command result codes should match the SY/MAX error codes whenever possible.*

**EXAMPLES**

**Example 1**—The following is an example of a command that does not require a parameter.

To reset the peak demand currents, do the following:

1. Write the command code for resetting the peak demand currents (5110) to the digital relay command interface register (7700).

**Example 2**—The following is an example of a command that requires a parameter (in this case, a password).

To reset the trip condition, do the following:

1. Read register 2028 to get the current password.
2. Write the parameter (e.g., password) to register 7701.
3. Write the command code for resetting the trip condition (1130) to the digital relay command interface register (7700).

**Example 3**—The following is an example of using the command interface to set the date and time.

To set the date and time, follow these steps:

1. Referring to table 24, write values to a series of command parameter registers, one for each time parameter: SEC, MN, HR, DA, MO, YR.

**Table 24: Date/Time Information**

Register No.	Value	Description
7700	1310	Command code to set date and time.
7701–7706	SEC, MIN, HR DAY, MO, YR	Seconds correspond to register 7701 Minutes correspond to register 7702 Hours correspond to register 7703 Day corresponds to register 7704 Month corresponds to register 7705 Year corresponds to register 7706

2. Write a command code (1310) to the digital relay command interface register (7700).

## APPENDIX L—TERMINAL BLOCK WIRING SPECIFICATIONS

Table 25 below shows wiring specifications for removable terminal blocks CCA 604, CCA 606, and CCA 608.

*Note: Table specifications apply to removable terminal block wiring only. They do not apply to the phase current sensor module (CCA 650).*

**Table 25**  
**Terminal Block Wiring Specifications**

No. of Wires	AWG	Torque in-lb (N•m)	Strip Length inches (mm)	Special Instructions
1	20–22 ①	3–5 (.34–.56 N•m)	.8–.9 (20–23 mm)	Fold back to double wire thickness ②
2	20–22 ①	3–5 (.34–.56 N•m)	.8–.9 (20–23 mm)	Twist stripped ends together and fold back to double wire thickness ②
1	16–18	6–9 (.68–1 N•m)	.4–.45 (10–12 mm)	None
2	16–18	6–9 (.68–1 N•m)	.5–.6 (13–15 mm)	Twist stripped ends together
1	14	6–9 (.68–1 N•m)	.4–.45 (10–12 mm)	None

① For example, the wires in a Beldon 8723 cable.

② To fold a wire back to double thickness, fold the tip of the *stripped* wire back to the strip mark. This doubles the thickness of the *stripped* portion of the wire. Each wire should now end with .4"–.45" (10–11 mm) of *doubled, stripped* wire.

Square D Company  
330 Weakley Road  
Smyrna, TN 37167 USA

Order No. 3030IM9301 March 1995

FP 2M 3/95



SQUARE D

Printed in USA