

SUPERSEDES:

Class 9065
Page 101
December, 1966



CLASS	9065
PAGE	101
DECEMBER, 1966	

THERMAL OVERLOAD RELAYS

Inverse Time Delay Trip

Thermal overload relays are used to protect motor winding insulation from overheating due to operating overloads. Excessive line current flowing through the thermal unit generates sufficient heat within the relay to actuate the trip mechanism and open a control contact. This contact is normally used to de-energize a magnetic contactor coil, disconnecting the motor from the line.

Several nominal sizes are available, with ratings to 300 amperes. Each size accepts a variety of interchangeable thermal units which are selected to provide the proper trip current for a given motor.

An inverse time delay characteristic results in progressively faster trip time as the degree of overload increases. Sufficient time delay is provided to prevent tripping on normal starting current or harmless momentary overloads, yet dependable tripping is obtained on prolonged overloads.

Operating overloads which overload relays are designed to detect include those caused by excessive mechanical load, low line voltage, single phasing of a three phase motor, excessive duty cycle, stalled rotor, etc. Overload relays are not suitable for interruption of short circuit or ground fault currents and must be protected by fuses or circuit breakers in accordance with the National Electrical Code.

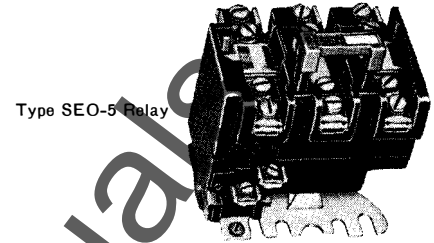

Type SEO-5 Relay

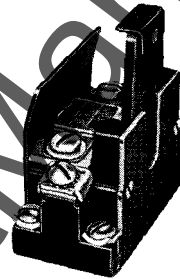

Type CO-1

Melting Alloy Hard Reset Type

600 VOLTS AC MAX. CLASS 9065 250 VOLTS DC MAX.

Description	Ampere Rating	General Purpose Enclosure NEMA Type 1		Open Type for Separate Panel Mounting			Open Type for Mounting on Terminal Block Channel					
		Type	Price *	Left Hand Type	Right Hand Type	Price *	Factory Assembled Unit		Components for User Assembly			
							Type	Price *	Type	Price *	Type	Price
SINGLE POLE CONSTRUCTION (ONE N.C. CONTACT PER RELAY)												
1 Relay	25	CG-1	\$ 13.	CO-1	CO-1R	\$ 6.	CO-1M	\$ 6.40	CO-1	\$ 6.	LM-1	\$ 0.40
	50	TG-1	20.	TO-1	TO-1R	8.	TO-1M	8.40	TO-1	8.	LM-1	0.40
	100	UG-1	27.	UO-1	UO-1R	10.
	150	FG-1	45.	FO-1L	FO-1R	15.
	300	GG-1	91.	GO-1L	GO-1R	56.
2 Relays	150	FG-2	65.	FO-2	FO-2R	30.
	300	GG-2	147.	GO-2	GO-2R	112.
3 Relays	150	FG-3	70.	FO-3	FO-3R	34.
	300	GG-3	208.	GO-3	GO-3R	168.
THREE POLE CONSTRUCTION (ONE COMMON N.C. CONTACT)												
1 Relay With 2 Thermal Units	30	SEG-5	20.	SEO-5	SEO-5R	12.	SMO-5	13.	SEO-5	12.	SM-2	1.00
	50	SEG-8	29.	SEO-8	SEO-8R	16.	SMO-8	17.	SEO-8	16.	SM-2	1.00
	100	SEG-12	33.	SEO-12	SEO-12R	20.

*Prices include overload relay thermal units. Deduct \$1.50 each if thermal units are omitted.

Relay has provisions for 2 or 3 thermal units as standard — add \$1.50 for third thermal unit.

ADDITIONS AND SPECIAL FEATURES — MELTING ALLOY TYPES

	Form	Price
Substitute 1 — N.O. and 1 — N.C. contact for standard N.C. contact per relay.....	Y34	\$ 4.
Modify 100 amp. relay to accept Type FB quick trip or JB slow trip thermal units (also accepts Type C (or CC) standard trip).....	Y21	N.C.
Modify 150 amp. relay to accept Type FB quick trip thermal units (rejects Type CC standard trip units).....	Y81	N.C.

<p>ORDERING INFORMATION REQUIRED</p> <p>1—Class and type number of device. 2—Form number if applicable. 3—Quantity and type number of thermal units.</p>	<p>THERMAL UNITS</p> <p style="text-align: center;">Refer to tab "Overload Relay Selection"</p>
---	--



THERMAL OVERLOAD RELAYS

Melting Alloy Type

APPLICATION DATA

Melting alloy overload relays make use of a eutectic alloy solder which responds to the heat produced in a heater winding by the load current. Melting of the solder allows a ratchet wheel to rotate, releasing a spring latch which actuates the trip mechanism. When tripped, the overload relay may be reset manually after allowing a few moments for the solder to solidify. Type F, G and S relays incorporate a trip-free reset mechanism which prevents reclosing the contact until the overload condition has been removed and the solder has hardened.

An **alarm circuit contact** (normally open) can be supplied on all melting alloy relays in addition to the standard normally closed contact. Type F, G and S relays with this feature (Form Y34) are furnished with a SPDT contact having one terminal common. On Type C, T and U relays the two contacts are electrically separate; contacts of Type F, G and S relays must be wired with same polarity. Form Y34 can also be added in the field on Type S relays by replacing the removable contact unit with a Class 9998 Type SO-2 contact unit.

A **unique one-piece thermal unit** includes the solder pot, ratchet wheel, and heater winding. Each of these tamper-proof thermal units is load tested at the factory to insure trip accuracy, and repeated tripping does not affect the original calibration. Thermal units for melting alloy relays are available in three designs — standard trip, slow trip, and quick trip.

Standard trip units provide proper trip characteristics for the majority of motors. They provide sufficient time delay for a motor accelerating time up to about 10 seconds on a full voltage start.

Slow trip units are for use with motors having an unusually long accelerating time, approximately 10 to 20 seconds on a full voltage start. When slow trip units are used, the motor should be of a type suitable for extended starting periods. These units can be used on standard 25 through 50 ampere relays, and can also be used on modified 100 ampere relays (Form Y21).

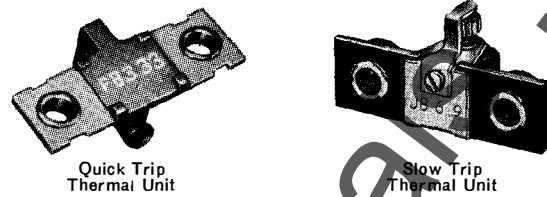

Quick Trip Thermal Unit

Slow Trip Thermal Unit

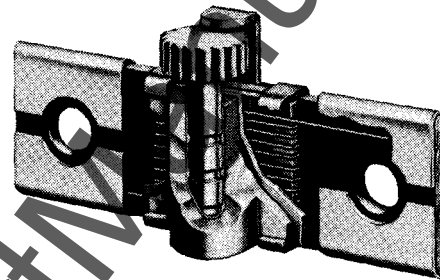

Cutaway View of Standard Trip Thermal Unit

Quick trip thermal units should be used for protection of hermetically sealed motors, submersible pump motors, and others which can endure locked rotor current for only a very short time. Such motors generally have a low ratio of locked rotor current to full load current. Standard 25 through 50 ampere relays will accept quick trip units. Use of these units on higher currents requires modification of the relay — specify Form Y21 on 100 ampere relays or Form Y81 on 150 ampere relays.

For additional information on selection and application of overload relays, refer to catalog tab "Overload Relay Selection".

Typical Trip Time Characteristics

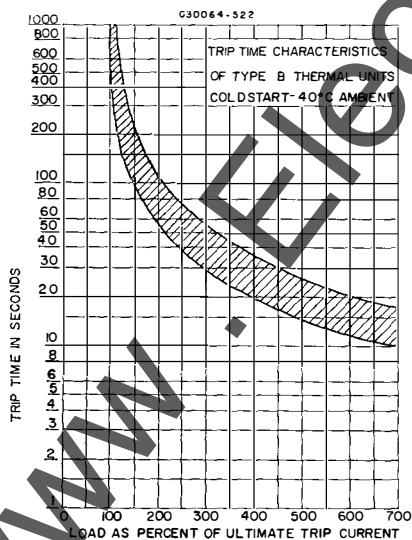

Figure 1
Standard Trip

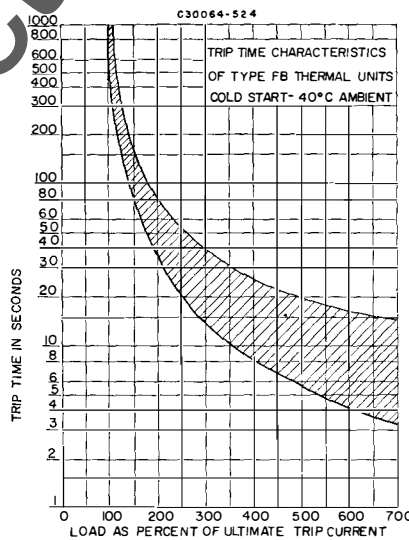

Figure 2
Quick Trip

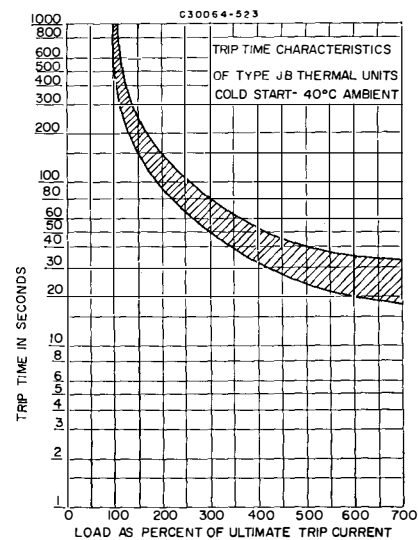

Figure 3
Slow Trip



THERMAL OVERLOAD RELAYS

CONTROL CONTACT RATINGS MELTING ALLOY TYPES C, G, T, U

Volts (Recommended Minimum— 110 Volts)	AC Pilot Duty (35% Power Factor)		DC Pilot Duty (Inductive)
	Make	Carry and Break	
120 or less 121-250 251-600	60 Amp. 7200 VA 7200 VA	6 Amp. 720 VA 720 VA	1.1 Amp. 132 VA

On Type T or U relays with Form Y34 the ac ratings shown apply to the N.C. contact only. Ampere and va ratings of the N.O. contact are 50% of ratings shown.

Contact ratings of Type G apply only to Types GG-1, -2, -3 and GO-1L, -1R, -2, -3.

CONTROL CONTACT RATINGS MELTING ALLOY TYPES F AND G

Volts (Recommended Minimum— 110 Volts)	AC Pilot Duty (35% Power Factor)		DC Pilot Duty (Inductive)▲
	Make	Carry and Break	
120 or less 121-250 251-600	60 Amp. 7200 VA 7200 VA	6 Amp. 720 VA 720 VA	0.6 Amp. 72 VA

On Type F relays with Form Y34 the dc ampere and va ratings of both N.C. and N.O. contacts are 50% of ratings shown.

Contact ratings of Type G apply only to Types GO-11L and GO-11R.

CONTROL CONTACT RATINGS MELTING ALLOY TYPE S

Volts (Recommended Minimum— 110 Volts)	AC Pilot Duty (35% Power Factor)		DC Pilot Duty (Inductive)
	Make	Carry and Break	
120 or less 121-600	30 Amp. 3600 VA	3 Amp. 360 VA	No dc rating

LINE AND LOAD TERMINAL DATA

Relay Size (Amperes)	Min. Wire Size ★	Max. Wire Size ★
25 or 30	(1) #14	(1) #8
60	(1) #14	(1) #4
100	(1) #14	(1) #0
150	(1) #4	(1) 250 MCM
300	(1) #4	(2) 350 MCM

★Solid or stranded copper wire.

Melting Alloy Overload Relays For Replacement on Class 8536 Starters ‡

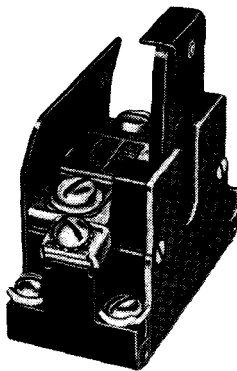

Type CO-1R
Melting Alloy
Overload Relay

Class 8536 Starter			Class 9065 Overload Relay		
No. of Poles	Size	Type	L. H. Type	R. H. Type	Price *
2, 3 or 4-Pole †	0	B (Series A Only)	CO-1	CO-1R	\$ 6.
	1	C (Series A or B)	CO-1	CO-1R	6.
	2	B (All)	TO-1	TO-1	8.
	3	E (All)	UO-1	UO-1	10.
	4	F (Series C Only)	FO-1L	FO-1R	15.
	5	G (Series B Only)	GO-1L	GO-1R	56.
	5	G (Series C Only)	●GO-11L▲	●GO-11R▲	56.
2 Pole with 1 Thermal Unit	0	SB (Series A)	SDO-4		6.
	1	SC (Series A)	SDO-4		6.
	1P	SC (Series A)	SDO-10		8.
	2	SD (Series A)	SDO-7		8.
	3	SE (Series A)	●SDO-11▲		10.
3 or 4-Pole with 2 Thermal Units	0	SB (Series A)	SDO-5		12.
	1	SC (Series A)	SDO-5		12.
	2	SD (Series A)	SDO-8		16.
	3	SE (Series A)	●SDO-12▲		20.

*Prices include overload relay thermal units. Deduct \$1.50 each if thermal units are omitted.

Relay has provisions for 2 or 3 thermal units as standard — add \$1.50 for third thermal unit.

†2 and 4-pole starters use one L. H. and one R. H. relay. 2-pole starters use one L. H. relay only. Each relay includes one thermal unit.

‡For use only on starters originally supplied with melting alloy relays. For older designs refer to appropriate service bulletin.

▲Replacement overload relays for Class 8536 Type G and Type SE starters will be available third quarter, 1969.

Melting Alloy Type Overload Breaker

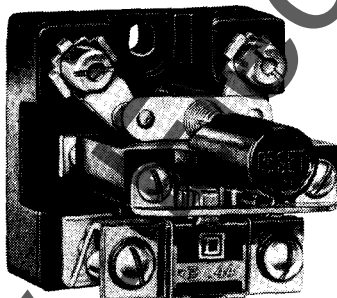

Type C
Overload Breaker

An overload breaker is similar in function to an overload relay, except that no magnetic contactor is required. The breaker contact is wired directly in the line and is capable of interrupting the

motor current. Type B and C overload breakers can be used with ac single phase motors or dc motors within their horsepower rating.

SINGLE POLE CLASS 9065 30 AMP., 250 VOLTS MAX.

Single Phase AC Ratings		DC Ratings		General Purpose Enclosure NEMA Type 1		Open Type	
Volts	Max. HP	Volts	Max. HP	Type	Price *	Type	Price *
115 230	1½ 3	115 230	¼ ¼	B	●\$25.	C	●\$15.

*Prices include one overload relay thermal unit. Deduct \$1.50 if thermal unit is omitted.

ORDERING INFORMATION REQUIRED

- 1—Class and type number of device.
- 2—Quantity and type number of thermal units.

THERMAL UNITS

Refer to tab "Overload Relay Selection"



THERMAL OVERLOAD RELAYS

Bimetallic Hand/Automatic Reset Type

Bimetallic overload relays incorporate a bimetal strip to detect heat produced by the thermal unit, which is a metal coil or strap of known resistance. Expansion of the bimetal actuates a snap-action switch to open the control circuit. Since the bimetal is "U" shaped, trip accuracy is maintained regardless of any slight variation in thermal unit mounting position.

Type ARO-1M
 Mounted on
 Class 9080 Terminal
 Block Channel

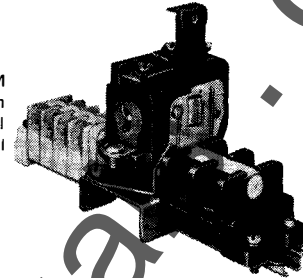

600 VOLTS AC MAX. CLASS 9065 250 VOLTS DC MAX.

Description (Single Pole Construction)	Ampere Rating	General Purpose Enclosure NEMA Type 1		Open Type for Separate Panel Mounting		Open Type for Mounting on Terminal Block Channel						
		Type	Price *	Left Hand Type	Right Hand Type	Price *	Factory Assembled Unit		Components for User Assembly			
							Type	Price *	Basic Relay		Bracket Kit	
						Type	Price *	Type	Price *	Type	Price	
1 Relay	25	ARG-1	\$ 13.	ARO-1L	ARO-1R	\$ 6.	ARO-1M	\$ 6.40	ARO-1L	\$ 6.	LB-1	\$ 0.40
	50	ATG-1	20.	ATO-1L	ATO-1R	8.	ATO-1M	8.40	ATO-1L	8.	LB-1	0.40
	100	AUG-1	27.	AUO-1L	AUO-1R	10.						
	150	AFG-1	49.	AFO-1L	AFO-1R	15.						
	300	AGG-1	91.	AGO-1L	AGO-1R	56.						
2 Relays	25	ARG-2	20.	ARO-2		15.						
	50	ATG-2	29.	ATO-2		19.						
	100	AUG-2	38.	AUO-2		23.						
	150	AFG-2	66.	AFO-2		36.						
	300	AGG-2	147.	AGO-2		112.						
3 Relays	25	ARG-3	32.	ARO-3		22.						
	50	ATG-3	43.	ATO-3		28.						
	100	AUG-3	54.	AUO-3		34.						
	150	AFG-3	88.	AFO-3		53.						
	300	AGG-3	208.	AGO-3		168.						

*Prices include one overload relay thermal unit per relay. Deduct \$1.50 each if thermal units are omitted.

APPLICATION DATA

Thermal units are of the standard trip type, suitable for motor accelerating times up to approximately 15 seconds on a full voltage start. Trip current is adjustable from 85 to 115% of nominal rating by means of a screw on the end of the relay.

When automatic reset is used, a three wire control circuit should be employed to prevent automatic restarting of the motor when the relay resets. All bimetallic relays are trip-free — pushing the reset button will not reclose the contact unless the overload condition has been removed and the bimetal has cooled.

Either hand or automatic reset can be obtained by repositioning a spring, which is set for hand reset at the factory.

CONTROL CONTACT RATINGS BIMETALLIC TYPES AF, AG, AR, AT, AU

Volts (Recom- mended Minimum— 110 Volts)	AC Pilot Duty (35% Power Factor)		DC Pilot Duty (Inductive)
	Make	Carry and Break	
120 or less	60 Amp.	6 Amp.	1.1 Amp.
121-250	7200 VA	720 VA	132 VA
251-600	7200 VA	720 VA

LINE AND LOAD TERMINAL DATA

Relay Size (Amperes)	Min. Wire Size ★	Max. Wire Size ★
25 or 30	(1) #14	(1) #8
50	(1) #14	(1) #4
100	(1) #14	(1) #0
150	(1) #4	(1) 250 MCM
300	(1) #4	(2) 350 MCM

★Solid or stranded copper wire.

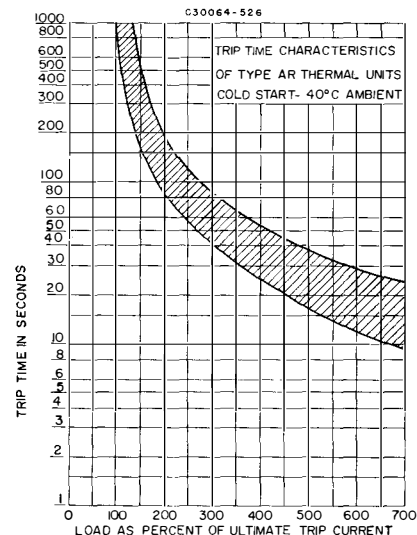

Figure 4

Type ARO-1L
 with Insulating
 Cover Removed



NEW SHEET

THERMAL OVERLOAD RELAYS

Approximate Dimensions and Shipping Weights

OPEN TYPES — THREE POLE CONSTRUCTION

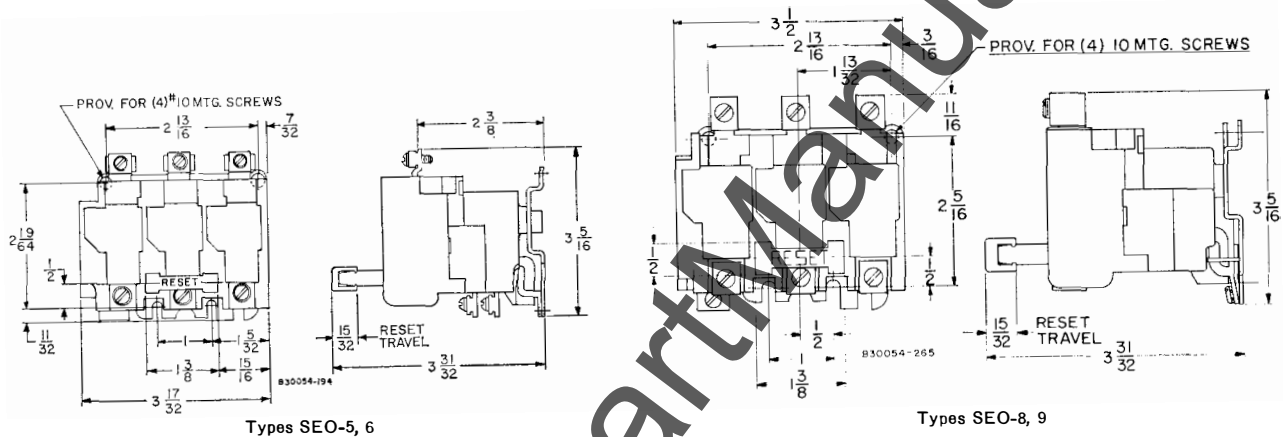

NEMA 1 ENCLOSED TYPES

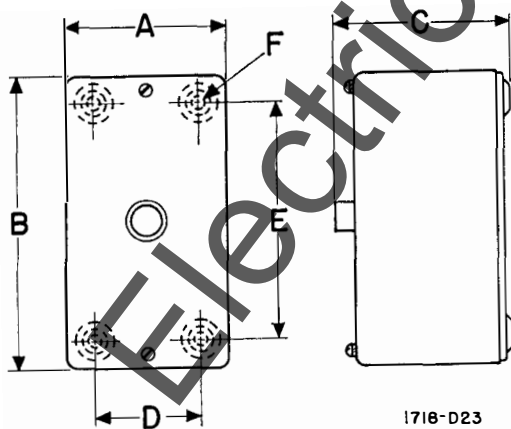

(For dimension reference only — actual construction may differ from figure.)

Type No.		Dimension						Weight (Lb.)
Melting Alloy	Bimetallic	A	B	C	D	E	F	
B	..	3 1/8	4 3/4	3 1/2	2	4	5/32	2 1/2
CG-1	ARG-1	3 3/16	6 3/8	4 15/16	1 1/2	4 7/8	5/32	3 1/2
CG-2	ARG-2	4 7/16	6 3/8	4 15/16	2 3/4	4 7/8	5/32	4 1/2
CG-3	ARG-3	4 11/16	8 3/8	4 15/16	3	6 7/8	5/32	6
SEG-5, 6, 8, 9	..	5 3/16	6 27/32	5 29/32	3 1/2	5 3/8	5/32	4 1/2
TG-1	ATG-1	3 3/16	8 3/8	4 15/16	1 1/2	6 7/8	5/32	4
TG-2	ATG-2	4 7/16	8 3/8	4 15/16	2 3/4	6 7/8	5/32	5 1/2
TG-3	ATG-3	6 11/16	8 3/8	4 15/16	5	6 7/8	5/32	7
.....	AUG-1	3 11/16	9 3/8	4 15/16	2	7 7/8	5/32	6
UG-1	..	6 11/16	12 3/8	4 7/16	5	10 7/8	5/32	8
.....	AUG-2	6 11/16	12 3/8	4 15/16	5	10 7/8	5/32	9
UG-2	..	6 11/16	12 3/8	4 7/16	5	10 7/8	5/32	9
.....	AUG-3	8 1/2	12 3/8	5 3/4	5 1/2	10	5/16	10
UG-3	..	8 1/2	17 3/8	6 1/2	5 1/2	15	5/16	16

www.ElectricalPartManuals.com