

**TOSHIBA**

6F9E0090

INSTRUCTION MANUAL

CURRENT RELAY

RC803A-HP1

**TOSHIBA** CORPORATION

CODE RY

www.ElectricalPartManuals.com

## CONTENTS

1.	General <b>Description</b> .....	2
2.	Check Before Using .....	2
2.1	External <b>Appearance</b> .....	2
2.2	Specifications .....	3
3.	<b>Description of Operation</b> .....	5
4.	<b>Applications</b> .....	6
4.1	Overcurrent Detection on Motors .....	6
4.2	Undercurrent Detection on Motors .....	8
4.3	Limiting Starting Current of Motors .....	9
4.4	Transformers .....	10
4.5	Heaters, <b>Lamps</b> and Other Circuits .....	10
5.	<b>Mounting</b> .....	10
6.	Adjustments .....	12
6.1	<b>Current Setting</b> .....	12
6.2	Setting the Detection Delay <b>Time</b> .....	12
6.3	Setting the Response Delay <b>Time</b> .....	13
7.	<b>Operational Test</b> .....	13
8.	Cover <b>Removal</b> .....	17

Please thoroughly read this instruction manual before using the RC803A Current Sensing Relay.

## 1. General Description

This current relay is designed to detect current in AC circuits with a wide range of applications, e.t., detection of abnormal current of various electrical equipment due to overloads or broken circuits (e.g., heater circuits), detection of starting current to automatically advance the secondary resistance on induction wound rotor motor controllers.

During starting, excessive current such as inrush current, may exceed rated current flow in motor or transformer circuits. This current relay has an adjustable delay circuit to prevent it from operating during start-up.

Further, this current relay is fail safe. The relay operates at the same time control power is applied, and the relay is de-energized when the input signal exceeds the preset level or control power is removed.

## 2. Check Before Using

Before using this relay, check the following points. If any defects are found, contact the dealer from which you purchased this relay.

### 2.1 External Appearance

Check the relay for any missing parts and for damage, dirt, rust, and loosened screws caused during transportation.

## 2.2 Specifications

ITEM	SPECIFICATION
Rated Current	<b>5A</b> (continuous)
Range of current sensing	0.5 - <b>5A</b> (For current above this range, use a CT (current transformer) and connect the relay to its secondary side).
<b>Input</b> circuit voltage	<ul style="list-style-type: none"> <li>▷ low voltage circuit (below AC <b>600V</b>)</li> <li>▷ To detect current in high voltage circuits, use a CT, and connect the relay to its secondary side.</li> </ul>
<b>Type</b> of Current	Overcurrent, Undercurrent
<b>Response</b> delay time-adjustable range	0.1 - 3s
Detection delay time-adjustable range	0.1 - 30s
Operating volt.	<b>5 - 132VAC, 170 - 250VAC, 50/60Hz</b>
<b>Accuracy</b>	<b>±10%</b>

ITEM	SPECIFICATIONS
Ambient temp. range	-10 - +50°C
Temp. error	±10% at ±30°C
Dielectric withstand voltage	Between terminals and ground <b>2000VAC</b> for 1 min.
Impulse withstand voltage	Between terminals and ground 1 X <b>40µs</b> at <b>4500V</b> (standard waveform)
Insulation resistance	Between terminals and ground <b>100H Ohms</b> or more when measured with a <b>500VDC</b> megger.
Vibration -Oscillation -Impulse	Amplitude <b>2.5mm - 20Hz (2G)</b> <b>15G</b>
Overcurrent intensity	40 times of max. continuous current ( <b>5A</b> ), for 1 sec., <b>applied</b> twice, in accordance with JEC 174.
Output contact rating (250VAC max.)	Over Current: SPDT Under Current; SPDT

<b>NEHA AC</b> Rating Designation B300	Inductive load		
	<b>Voltage</b>	Break	Continuous
	120 AC	<b>5A</b>  (p. f. =0.4)	<b>5A</b>
	240	3A	<b>5A</b>
	24	<b>0.3A</b>	<b>5A</b>
	DC 120	<b>0.15A (L/R=15ms)</b>	5A
240	<b>0.1A</b>	5A	

ITEH	SPECIFICATIONS
Hysteresis	<b>Approx. 10X of operating value.</b>
Power consumption	<ul style="list-style-type: none"> <li>○ <b>Operating Power 3.5VA</b></li> <li>○ <b>Input Circuit 0.1VA (when 5A is applied)</b></li> </ul>
Height	<b>.75kg (1.7 lb)</b>

**3. Description of Operation**

When the detected current exceeds the detection circuit operating level, the detection delay timer is actuated. If **over-current** is continuously detected for more then the detection delay time set value, the overcurrent response delay timer is actuated. Then, if overcurrent is detected when the **response** delay timer has elapsed, the overcurrent relay is actuated.

- ◆ If current drops below the undercurrent detection set **value**, the **response** delay timer is actuated, and after the set tile has **expired**, the undercurrent detection relay is actuated. In the case of undercurrent detection, the detection delay timer is not actuated.

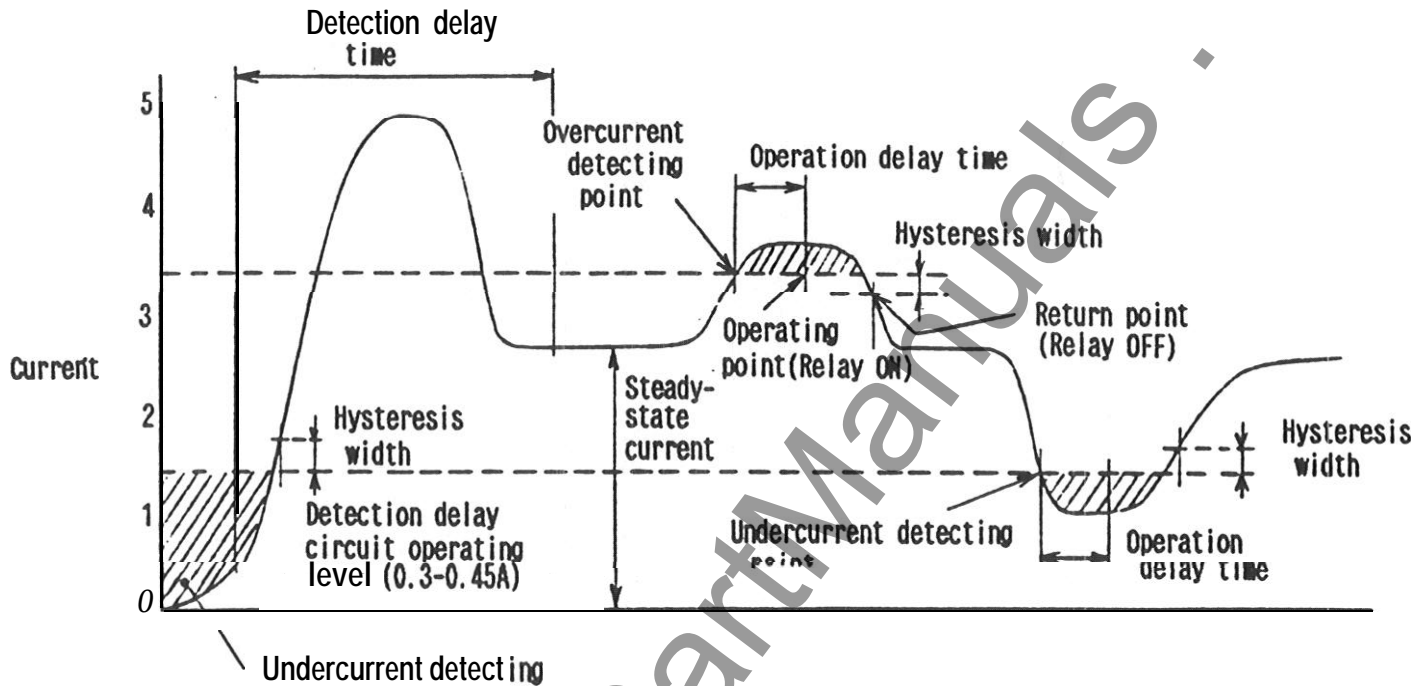

Fig. 1 Characteristics

#### 4. Application

##### 4.1 Overcurrent Detection on Motors

An application example is shown in Fig. 2. In this circuit, an excessive load is detected by detecting the overcurrent of a motor and the main circuit is opened to protect

the motor from being damaged. If the detected current is above 5A, and in case of a high voltage circuit, use an external CT and connect the secondary side of CT to the relay as shown in the following figure:

AC3-Phase Power Supply

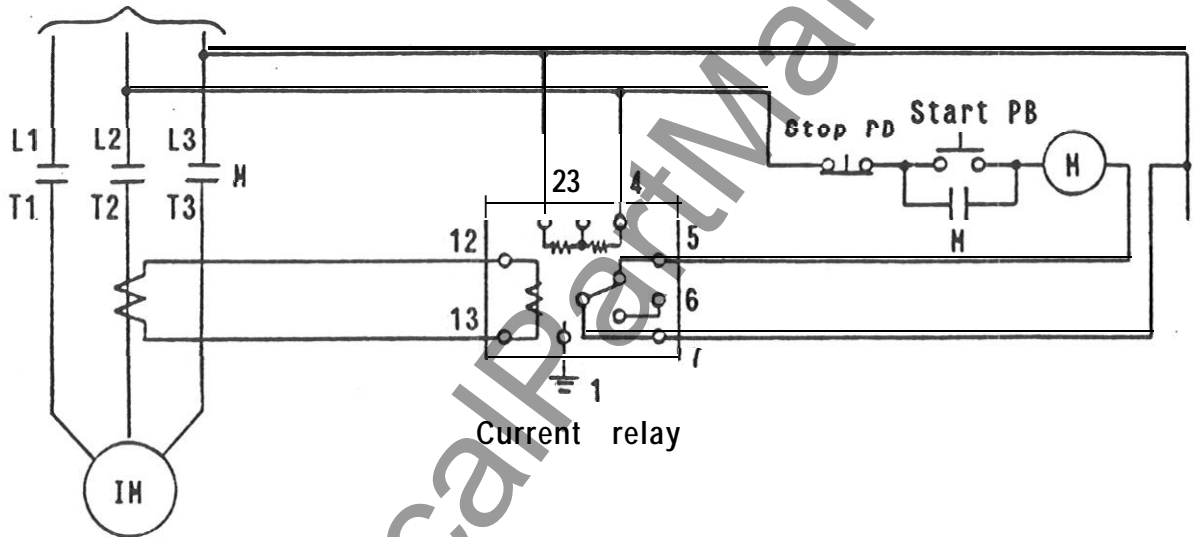

Note: The RC803's output contacts are shown with Dower source applied.

Fig. 2 Application Example using An External CT

further, when this relay is used in a **motor** circuit, the detection delay **timer** should be set **longer** than the starting time (about 120%) so that this relay is not actuated by inrush current. If current flowing in the **main** circuit **becomes** abnormal after the **time** Period of the detection delay timer has **elapsed**, the relay is actuated when the set **time** of the response delay **timer** is over.

#### 4.2 Undercurrent Detection on **Motors**

To utilize the undercurrent detection function, the **relay** is used in a **motor** circuit with a fixed load, to detect light or no load conditions. For **example**, in the case of a **pump motor**, this relay is used to detect undercurrent when the **volume** Of water **supplied** in a water **pipe** is low, or in case of a thread winding machine, when the tension of the thread **drops**.

AC3-Phase Power Supply

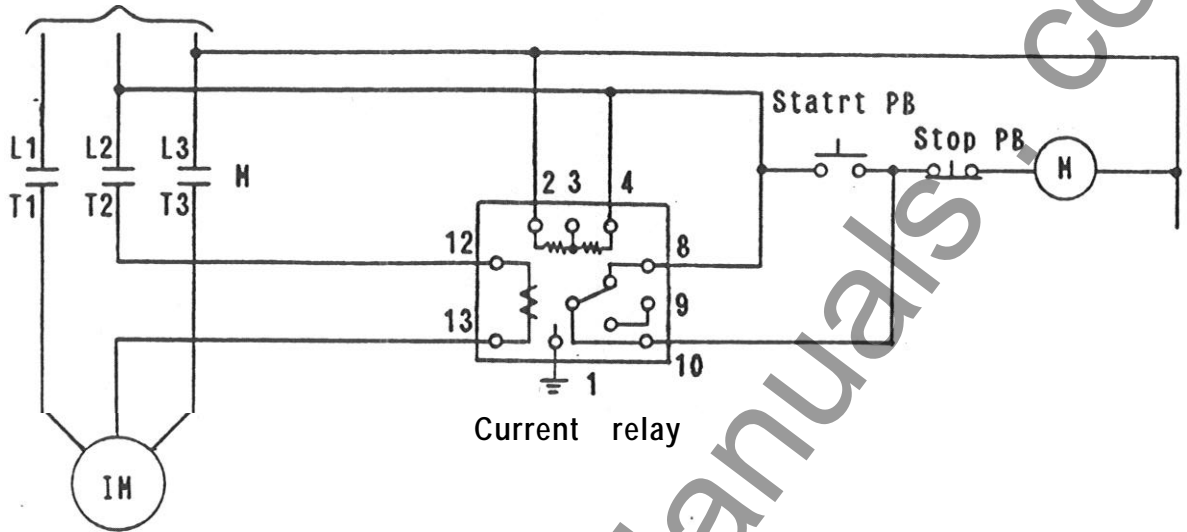

Note: The RC803's output contacts are shown with Dower source applied.

Fig. 3 Application Example

#### 4.3 Limiting Starting current of Motors

Many motors of medium and large capacity use a method to start by limiting starting current. By detecting the main circuit current, this relay can automatically advance the starting resistance on the secondary side of the motor (in this case, the knob of the detection delay timer and that of the response delay timer should be kept at the minimum settings).

#### 4.4 Transformers

To use this current relay for detecting overcurrent on transformers, it is necessary to set the detection delay timer with the inrush current of transformer taken into consideration.

#### 4.5 Heaters, Lamps and other Circuits

This relay can be used to detect the disconnection of circuits by sensing the existence of current flow. In other words, if disconnection occurs, current does not flow and an undercurrent condition is detected by the relay. For example, this relay can be used to detect the disconnection of heater circuits on constant temperature ovens or heater circuits for insulators on transmission and distribution facilities in extremely cold regions.

#### 5. Mounting

See Fig. 4 for mounting dimensions. Be careful not to use this relay in the following conditions:

- (1) Locations in ambient temperatures outside  $-10$  -  $+50$  °C,
- (2) Locations subject to high temperature, steam or dripping water,
- (3) Dusty/dirty locations,
- (4) Locations subject to vibration (total amplitude 2.5mm or more, 20 times/sec. or more) and shock (above 15G in 3 directions).

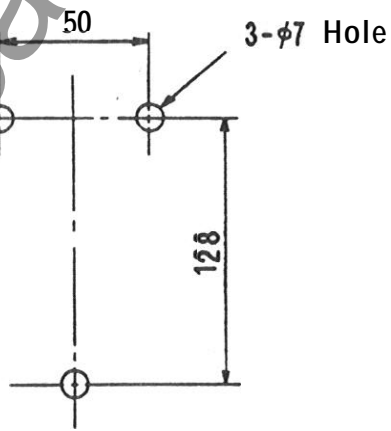
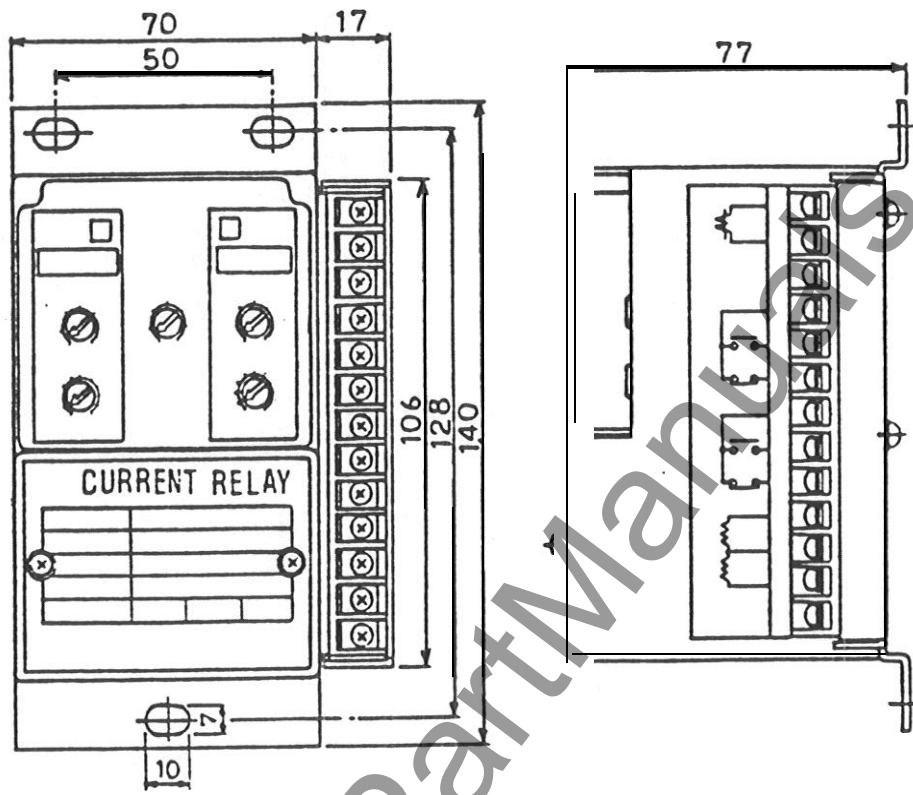

Hountino holes

Fig. 4 Dimensions

## 6. Adjustments

### 6.1 Current setting

(1) When detected current is in a range of 0.5 - 5A:

After confirming that the current value under **normal** load condition is in a range of 0.5 - 5A, set the current adjusting knob to the desired detecting value.

(2) When detected current is above 5A:

Using an external CT (current transformer), **properly** suited for the detected Current value, connect the secondary side of the CT to the **input terminal** of the relay. Calculate the secondary current **corresponding** to the detected current value, based on the CT ratio. Then set the current adjusting Knob to this calculated value.

### 6.2 Setting the detection delay time

Setting time varies depending **upon** each individual **application**. Adjust the detection delay **time** according to the following:

(1) **Motor** load

To avoid detection during start-up, set the delay time to **approximately** 120% of starting **time**.

(2) **Transformer** load

If the inrush current (inrush time varies **depending upon capacity**) is large, set the delay **time** to **approximately** 120% of this inrush **time**. **Generally, if the capacity is small**, inrush **time** is short and therefore, even when the adjusting knob is set at the **minimum** position, there should not be any nuisance tripping.

### 6.3 Setting the Response delay time

Adjust the set time according to the purpose of detection (i.e. overcurrent or undercurrent). The set time for the response delay varies per application. Most applications may not need any delay time. It is mainly used to prevent nuisance tripping (ride through) by ignoring momentary load glitches.

### 7. Operational test

- (1) Check both the control and detection circuits to confirm there is no mis-wiring.
- (2) Check if the current detection time delay, and response time delay settings are correct.
- (3) If the wiring and settings are correct, energize the control circuit and check if it is the proper voltage.

- (4) When the Dower source is applied, the relay is excited and the output contact's states are reversed. The relationship between the input signal and the output contacts are shown in Table 2. Check this relationship during the test.

Input		Output Contact Status			
Power source	signal operating level	Overcurrent		Undercurrent	
		Between 5 and 7	Between 6 and 7	Between 8 and 10	Between 9 and 10
OFF	Zero	Open	Close	Open	Close
ON	Less	Close	Open	Close	Open
	Above	Open	Close	Open	Close

Table 2

- (5) If no problem is found when the Dower source is applied, turn the rain circuit switch ON and perform the following checks:

(a) In the case of a motor load

If the set start-up time delay is too short, the relay may be actuated. In such a case, reset the detection delay time adjusting knob accordingly. After the start-up time delay has expired, apply current above the set detection value to confirm that the relay functions (after the response delay time). In addition, check that the detection indicating lamp lights at the same time the relay operates.

(b) When undercurrent or disconnection is detected

At the same time the main circuit switch is turned ON, the starting current and rated current flows, and the relay is picked Up. If current drops below the undercurrent set point, the undercurrent State is detected and the relay drops out.

(Refer to Fig. 5)

Caution: If input signal to this current relay is zero (When stopped), it is not possible to judge if it is undercurrent or in a disconnected state. In this case, it is recommended to have a circuit connecting a normally open auxiliary contact of the main circuit switch in series with the alarm or lamp circuit. this will prevent the relay from signalling a fault condition during a normal shutdown.

- (6) If the relay does not operate in the above test, check if the current setting is correct or if the input signal is above the set detection value. If the input signal is correct, check the operation of the relay by gradually reducing the setting of the current adjusting knob. If the relay still does not operate, it is defective. In this case, please contact the dealer from which you purchased the relay or Toshiba.

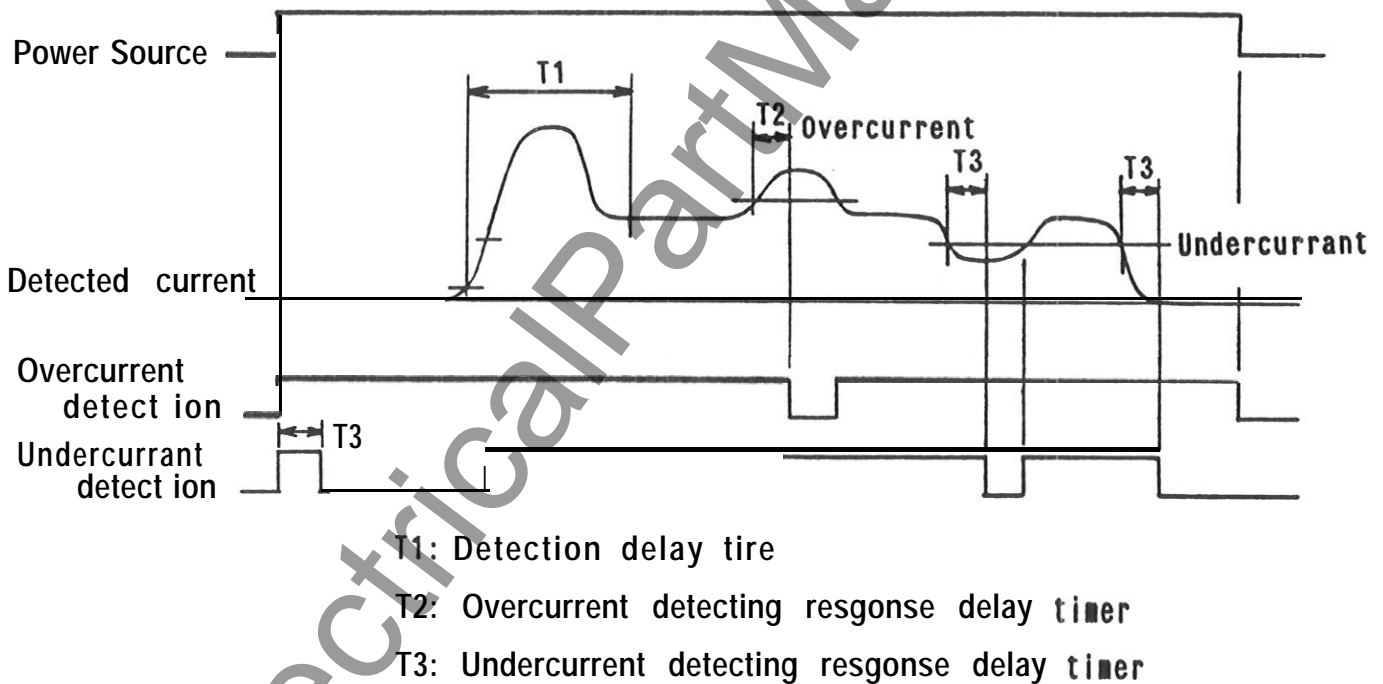
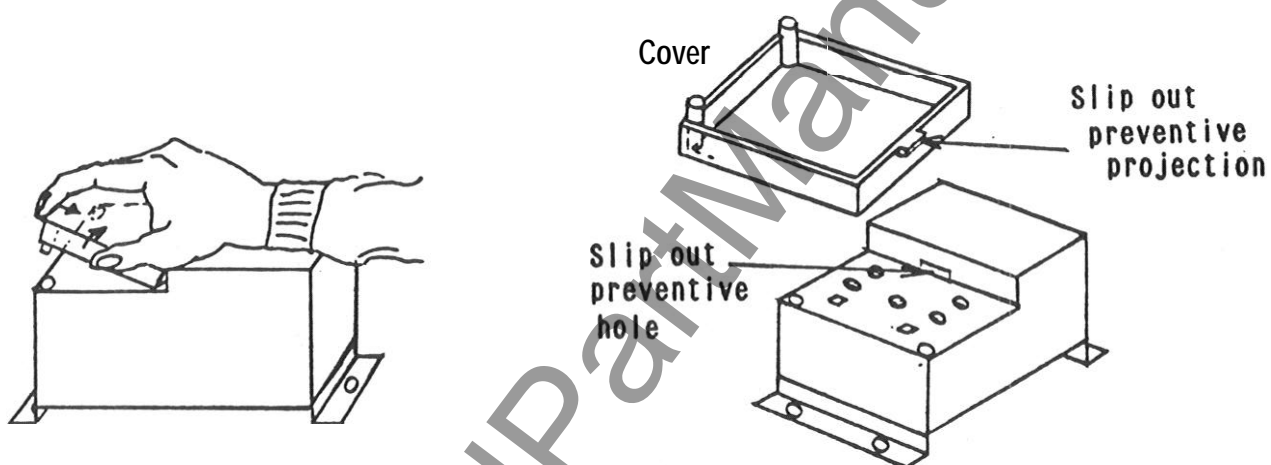

Fig. 5 Relay Operation

### 8. Cover Removal

To adjust the current and time settings the cover must be removed. Remove the cover by applying a force in the direction of the arrow as shown below. To replace the cover, place the projection of the cover in the slip out preventive hole and then insert the bosses of the cover into the 2 holes at the upper left and right.





TOSHIBA CORPORATION

---

www . ElectricalPartManuals . com