

Westinghouse

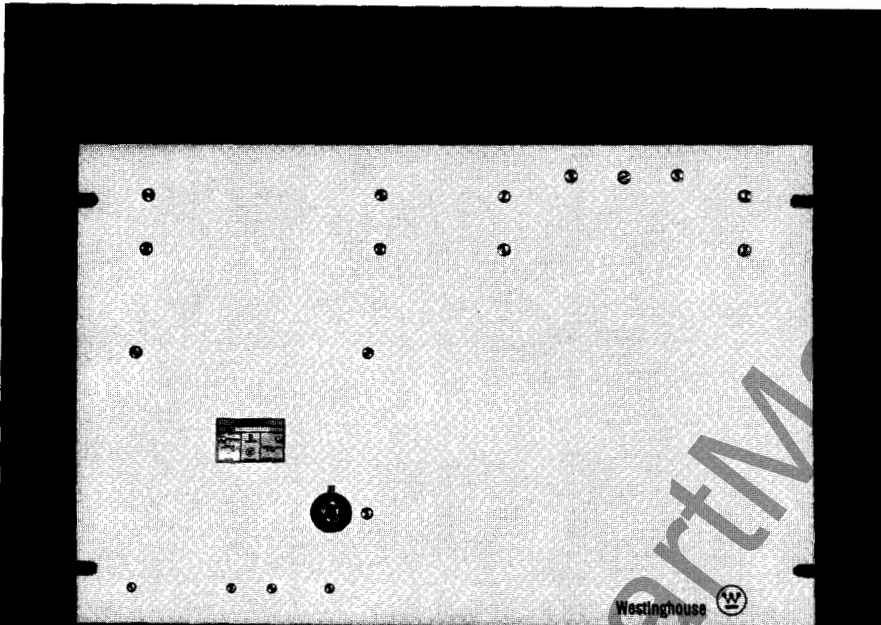

3-Frequency TCF Power Line Carrier Frequency Shift Transmitter and Receiver



Front View

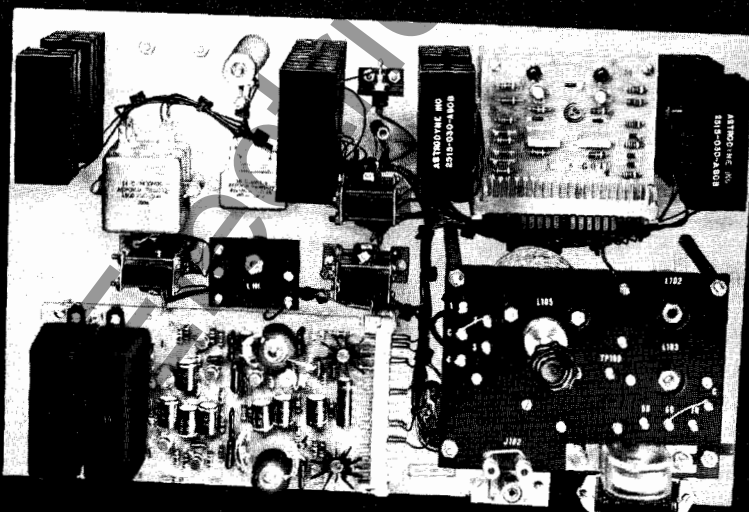

Rear View

The 3-Frequency TCF power line carrier is uniquely Westinghouse. It combines the two separate carrier relaying functions of unblock and transfer-trip onto one "double-shift" frequency-shift transmitter.

Unique User Advantages

1. Cost saving to the user. Only one three-frequency transmitter is necessary whereas 2 two-frequency transmitters were previously required. At least one r-f hybrid can be eliminated.
2. Allows the user to make approximately 30% better utilization of the carrier frequency spectrum. There is only one channel in each direction instead of two.
3. Less equipment is required, hence the reliability is improved. One less TCF transmitter and one less r-f hybrid required when using a three-frequency TCF channel.
4. 3-db improvement of signal level with the elimination of hybrid.

3-Frequency TCF Application

The three-frequency TCF equipment is designed to provide two relaying channels in less bandwidth than two separate channels. The channels used are frequency shift; one is wide band for use with line relaying, the other is narrow band for direct transfer trip relaying.

The total system uses one transmitter and two receivers. The transmitter normally transmits a center frequency which is guard to both relaying channels. The transmitter shifts up by 200 Hz for line relaying and down by 200 Hz for transfer trip. If the transmitter is keyed by both functions at the same time the transfer trip function has priority. At the receiving terminal two receivers are applied with the frequency separation such that the discriminator characteristics overlap. See Fig. 1. The receiver logic for line relaying is for use with the type STU relay in the unblock system while the other receiver has logic for use with the STU-91 or STU-92 for direct transfer trip relaying.

The use of the three-frequency TCF system provides a 30% reduction in the needed bandwidth over using two separate channels. Also, less channel equipment is needed to provide the two separate relaying functions.

Westinghouse



3-Frequency TCF Operation

One widely used high-speed relaying system for line protection consists of directional-comparison unblock relaying plus a transfer-trip channel for breaker failure protection. Both these systems of relaying require duplex frequency-shift channels, wide band for unblocking and narrow band for transfer-trip.

A considerable saving in channel spectrum can be effected by using a double-shift transmitter for the two relaying functions and two separate receivers, one for each function. The transmitter normally operates at a frequency that is 100 Hz above the nominal or rated channel frequency (f_c). This frequency serves as the guard frequency for the transfer-trip receiver and as the blocking frequency for the unblock receiver. Note that the discriminator characteristic in the unblock receiver is reversed to accomplish this arrangement. For an unblock operation, the TCF transmitter shifts upward by 200 Hz to the unblock frequency. If a subsequent transfer-trip operation is called for, the transmitter will shift to $f_c - 100$ Hz which is the trip frequency for the narrow-band receiver.

When the transmitter shifts to unblock, the frequency is completely outside the pass-band of the narrow-band transfer-trip receiver. Normally this would cause a low-signal alarm output from that receiver. Similarly, when the transmitter frequency is shifted to trip ($f_c - 100$ Hz), the signal is well removed from the block peak of the wide-band receiver discriminator. In order to prevent a similar alarm output in this case, the checkback output of each receiver is cross-connected to the guard or block input of the opposite receiver (through an OR logic circuit). This feature is shown in Figure 2 (Drawing 203C483) which shows the complete logic of both receivers. The checkback output indicates that a proper signal has been received without going through any time delays or other logic used for the actual relaying output. With these cross-connections, both receivers will function when required, but will not give any incorrect output indications.

The transmitter normally operates at an output level of one watt at the guard and blocking frequency, but increases to ten watts for either trip or unblock output. An interlock is provided in the transmitter keying circuit to give transfer-trip preference. This means that even while the transmitter is shifted to the unblock frequency, if the transfer-trip keying circuit is energized, the transmitter will shift to the transfer-trip frequency with no delay.

TCF Three-Frequency Operation - Receiver Characteristics

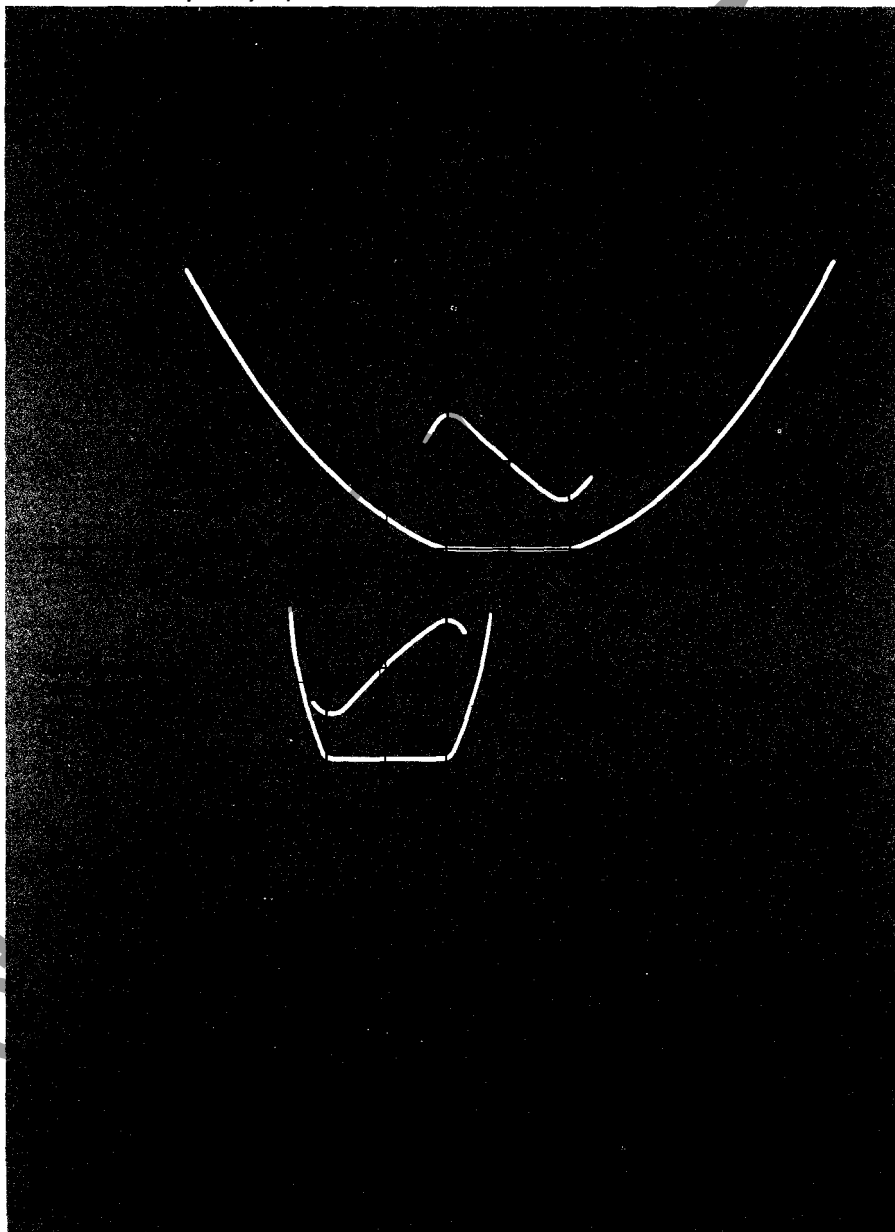

Figure 1

3-Frequency TCF Power Line Carrier Frequency Shift Transmitter and Receiver

Type TCF Receiver Three-Frequency Block Diagram
For Direct Transfer-Trip and Unblock Relaying

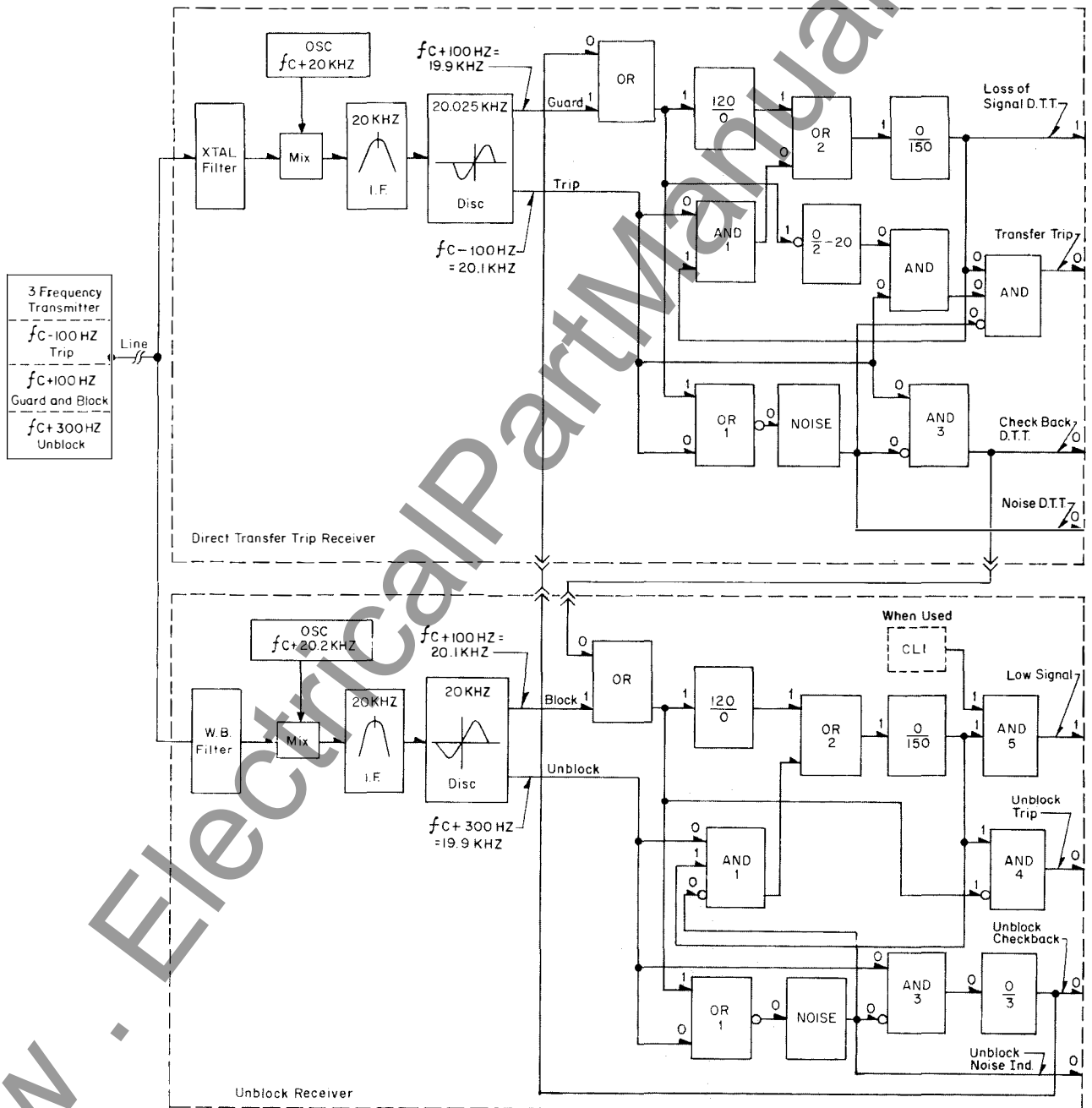

Figure 2

203C483

**3-Frequency TCF
Power Line Carrier
Frequency Shift
Transmitter and Receiver**

Characteristics

3-Frequency Transmitter

Function	Output	Frequency Range: Hertz	Input Voltage DC	Battery Drain	Chassis Temperature Range	Dimensions: Inches		Weight: Lbs.	Instruction Leaflet Reference
						Height	Width		
Transfer-Trip	1-Watt Guard; 10-Watt Trip and Unblock	30-300 kHz	48	.5 Amp Guard 1.15 Amp Trip	-20° to +55°C	12¼	19	12	IL 41-945.12
			125	.5 Amp Guard .9 Amp Trip					
			250	1.5 Amp Guard and Trip					
Receiver for 3-Frequency									
		30-300 kHz	48	.20 Amp	-20° to +55°C	10½	19	13	41-945 Series
			125/250	.27 Amp					

Further Information

Prices and Ordering Information: Price List 41-020

Instruction Leaflets: IL 41-945.12