

INSTRUCTIONS FOR  
ALLIS-CHALMERS TYPE 210  
INSTRUMENT AND CONTROL SWITCHES

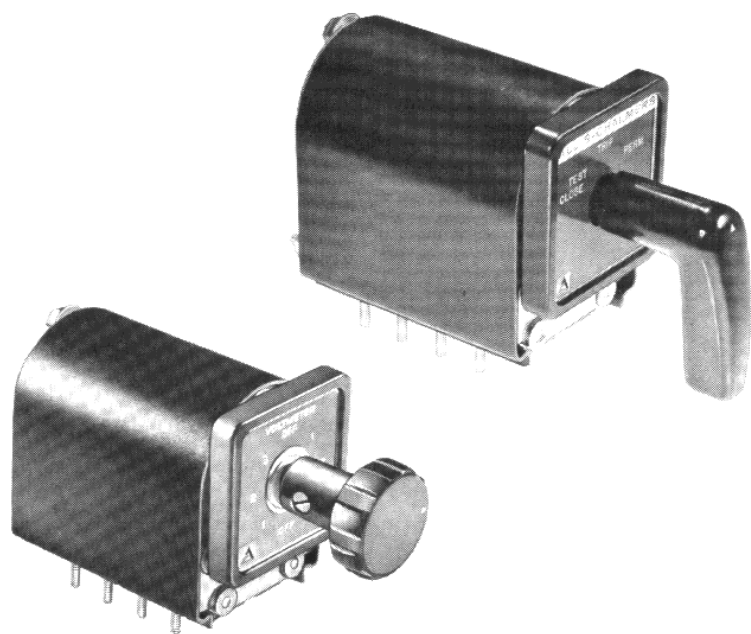

Fig. 1—Standard 210 instrument switch with four stages.

#### DESCRIPTION

Type 210 Instrument and Control switches are available as either maintained or spring return contact types. These switches are available with or without pullout feature and with fixed or removable handles. They are used in conjunction with such instruments as circuit breakers, transformer tap changers, motor-operated rheostats, and many other types of electrically controlled apparatus. Switches are designed for panel mounting.

Switches may be furnished with a magnetic release mechanism, in which an operating magnet is used to trip the switch (Fig. 4). *The switch must be reset manually.*

The Type 210 switch circuits are usually connected from a stud on one side of the terminal base through a segment of the shaft assembly to a stud on the other side. This constitutes a single contact or stage. A stage is a single-pole, double-break, single-throw contact. In other switches involving various sequences and connections to the same circuit, the entire switch may serve as a single-pole.

The operating shaft (14) is made of 3/8-inch square, cold-rolled steel and rotates on nickel-plated brass bearings. The end plates (1) and (2) provide ample support for the shaft (14) and base block (5). They assure permanent alignment of the contacts. Movable contact segments (26) and (27) are made of silver-plated brass.

The stationary contacts (6) and (7) are made of heavy phosphor bronze and are silver-plated. This means low contact drop throughout the life of the switch even under conditions of oxidation or other corrosion. The rotating contacts (26) and (27) are separated by high resistance insulators (20). A square, linen-base phenolic insulation (15) covers the shaft. It is a strong, high grade insulation and is impervious to humidity. Spacers (25) and contacts (26) and (27) are held on the shaft by a screw and lockwasher. High compression springs give excellent contact pressure. The contact construction utilizes a self-aligning, wiping action. This assures clean, low resistance contact and means longer operating life. Copper shunts conduct the current from the contacts to the terminal studs. The studs are mounted on the base block and are designed so they cannot come loose.

Terminal base block (5) is made of molded, industry quality phenolic and has high mechanical and dielectric strength. Each terminal base is numbered for identifying the connection from the wiring diagram.

#### OPERATION

All Type 210 switches are made for partial or full 360 degree rotation with 2 to 12 radial positions. Spring return switches are made for three positions but can be furnished for a maximum of seven positions, three from either side of center position. Maintained contact switches are available from 2 to 12 positions. Any increase in the number of positions decreases the travel between positions and reduces the interrupting capacity.

Circuit breaker control switches have a window in the position plate with a red and green flag indicator to show the last operation of the switch. In the trip position, the signal lamp circuit can be opened by pulling the handle into the latch position. When latched the lamp is not lighted up, indicating that the circuit controlled by the breaker is not in use. Voltage control, speed control, and motor control switches are not usually furnished with the flag indicator or pullout feature. The rotating contacts of the Type 210 switch are mounted on a square insulated shaft. Contacts may or may not be electrically insulated from each other, depending upon the desired circuit. In operation, circuits are completed across various members of stationary contacts or a continuous circuit is maintained across two or more stationary fingers for a number of switch positions by means of conductive spacers. The stationary contacts

TABLE I - TYPE 210 SWITCHES AVAILABLE

| Description  | 2 Contacts Per Stage | 3 Contacts Per Stage                   |
|--|----------------------|--|
| With indicator flag; spring return and pull-out                            | Type 210-1           | Type 210-11                            |
| No indicator flag; no spring return; no pull-out                           | 210-2                | 210-12                                 |
|  | 210-52*              | 210-62*                                |
| No flag; no spring return; key handle                                      | 210-3                | 210-13                                 |
|  | 210-53*              | 210-63*                                |
| No pull-out; no flag; with spring return                                   | 210-4                | 210-14                                 |
| Coil operated release; manual reset  | 210-5                | 210-15                                 |
| Pull-out with horizontal spring return; no spring return                   | 210-6                | 210-16                                 |
| Pull-out with lock at 10° from "off"; no spring return                     | 210-7                | 210-17                                 |
| Mechanically driven; no handle; no face plate; no positioning wheel        | 210-8                | 210-18                                 |
| Pull-out with lock at 10° from "off"; with spring return                   | 210-9                | 210-19                                 |
|  | 210-59*              | 210-69*                                |
| Spring return; no flag; pull-out and lock-in 2 positions                   | 210-10               | 210-20                                 |
| Spring return; no flag; pull-out in center position                        | 210-21               | 210-31                                 |
| Spring return; with flag; no pull-out                                      | 210-22               | 210-32                                 |
| 2 key handles; each handle turns switch in one direction only              | 210-23               | 210-33                                 |
| 2 gang, switch   | 210-24               | Can be either 2 or 3 contacts or both. |
|  | 210-25               | 210-35                                 |
| 3 gang, switch   |                      |  |
| Coil-operated release, spring return, slip contacts; pushbutton type       | 210-26               | 210-36                                 |
| Rotary and horizontal spring return; pull-out, no lock                     | 210-27               | 210-37                                 |
| Rotary and horizontal spring return with removable key handle              | 210-28               | 210-38                                 |
| Special construction (not suitable in any of the above for classification) | 210-SP               | Either 2 or 3 contacts per stage.      |

\*New Style - Positive Positioning

(6) and (7) and positioning fingers (8) are mounted on finger supports. These, in turn, are mounted on a base of insulating material. Contact pressure is provided by a spring. External connections are made to the stationary contact finger through terminal studs below the base.

A new positive positioning device features a star-shaped position wheel, two roller arm assemblies and two tension springs. The peaks around the outline of the position wheel virtually eliminate any hang-up area. This, combined with the push-pull effect of the roller, makes in-between positioning impossible.

A positioning wheel (22) and two stationary fingers hold the shaft assembly in each position on maintained contact switches. Mounted on the operating shaft (14), the notched positioning wheel corresponds to the number of switch positions. Spring action engages the positioning finger by the notches in the positioning wheel. This holds the switch in the desired position. The switch also is designed to provide a spring return.

Because interrupting capacity depends on the current, voltage and inductance of the circuit and the speed of contact opening, control relays should be used with

control switches on heavy currents. These switches are made in standard construction for up to fourteen circuits. In many cases, additional circuits may be provided.

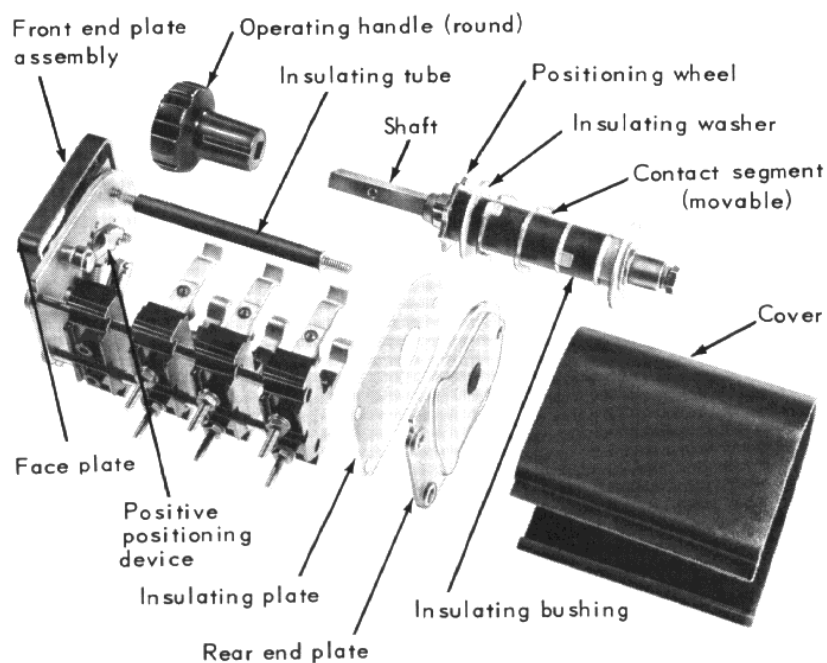

Fig. 2 - Dismantling is easy and quick on all 210 switches.

## GENERAL DATA

Ratings . . . Type 210 switches are rated for 20 ampere continuous capacity with 600 volts insulation.

| Circuit Voltage | Momentary Interrupting Amps |                       |
|-----------------|-----------------------------|-----------------------|
|                 | Inductive Circuit           | Non-Inductive Circuit |
| 125 ac          | 30                          | 50                    |
| 250 ac          | 15                          | 25                    |
| 600 ac          | 3                           | 5                     |
| 125 dc          | 4                           | 8                     |
| 250 dc          | 1                           | 2                     |
| 600 dc          | 0.2                         | 0.5                   |

The following data applies to the Type 210 switches when the contacts are new:

Normal Contact Lift – Min. 1/32-in.; Max. 1/16-in.

Required Contact Pressure – 10 to 12 ounces

Wear Allowance – 1/32-in. per contact

## MAINTENANCE

The only maintenance required is to periodically examine the stationary contact fingers (6) and (7) and movable contact segments (26) and (27) for wear. Contacts should be replaced when the wear is approximately 1/32-in. per contact.

**Lubrication:** A few drops of light machine oil on the bearings (16) and (18) every six months and a thin film of vaseline on the contact surfaces are the only lubrication requirements on the switches.

**Replacing a Stationary Contact:** To remove a stationary contact (6) and (7), first remove the cover (12) and then remove the hex nuts, lockwashers, washers and leads on the contact terminal. This frees the contact assembly from the switch base (5). Next remove the cotter pin, washer, contact spring and contact finger from the support. Replace with new contact finger and and new spring if necessary.

**Replacing a Movable Segment:** Should the movable segments (27) or slip contacts (26) have to be replaced, remove the switch from the panel. First remove all wiring to the switch, be sure each lead is coded, and then remove handle (13). Press the position plate (11) in on the side that has a dot, then slide under the face plate (10) and back out. Slip the position plate off the shaft (14). Unscrew the three flat head mounting screws and remove the switch from the panel.

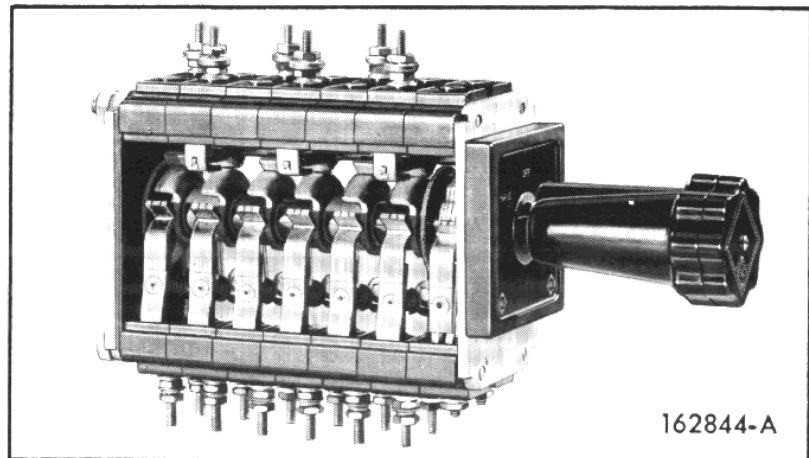

Fig. 3 – Type 210 switch with 3 contacts per stage construction.

All segments, excepting the slip contacts, are coded by a number stamped on each segment. It is best to make a sketch of the position of each segment on the shaft and show the location of the conductive and non-conductive spacers between segments. Notice that the actuator on the slip contact bushing is opposite the file mark, on the front end of the shaft or pointing down. In addition, note the position of the slip contact segment, as the contact surface is longer on the side of the slot which engages the bushing actuator of the slip contact(9).

The letters indicate the position of the shaft. The number indicates the position of the prick punch on the segment with respect to the file mark or cut-out portion at the front of the shaft. Thus, each segment is coded such as A-1, B2, C-3, etc. (Fig. 8). Section "V-V" (Fig. 9) shows the position of the numbers with respect to the file mark. The positioning wheel also has an indicating punch mark.

To remove the shaft (14) from the switch, remove the three hex nuts and lockwashers holding the front end-plate (1) to the switch, and slip out the shaft from the switch. Remove the hex nut, lockwasher and washer from the end of the shaft. The bearing bushing (18), insulating washer (19), insulating bushing (20), movable

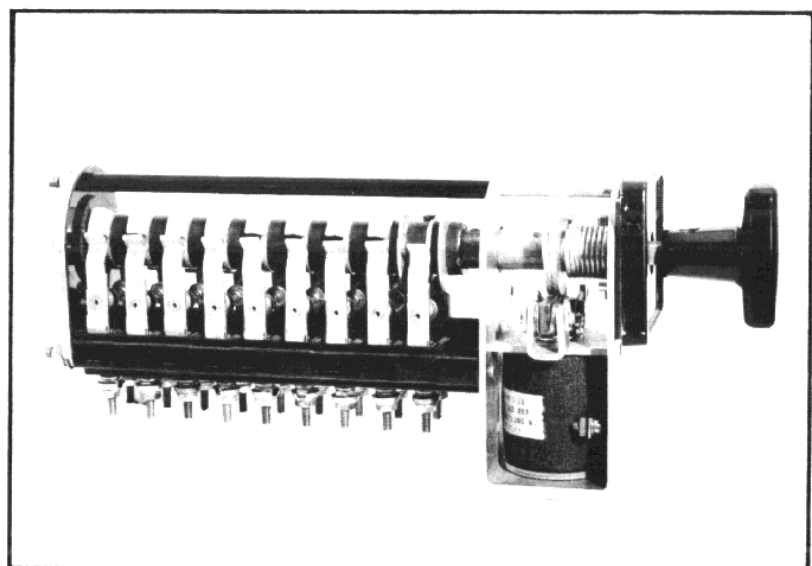

Fig. 4 – Type 210-5 control switch.

contact segments (26) and (27), and spacers (25), may be slipped off the shaft. Notice the relative positions of the contact segments, conductive and non-conductive spacers so that they will be returned to their correct place and position.

**Replacing a Rotary Return Spring:** Follow the above procedure in removing the shaft from the switch and the spring (23) can be slipped off of the front end of the shaft. When replacing the new spring, press the spring ends and insert the spring on the shaft with the spring ends surrounding the pin on the shaft stop plate. Insert the assembled shaft on the switch. Be sure the large washer (19) in front of the spring is in place. Slide the shaft assembly forward, inserting the bearing pin (17) on the front end plate (1) between the spring ends and over the bearing pin on the shaft stop plate (22).

**Replacing a Horizontal Pull Out Spring:** In applications where both return spring and horizontal spring return are used on a switch, the horizontal spring return is mounted in the front of the shaft and the return spring is mounted at the rear of the shaft. To replace a horizontal spring return (23), follow the procedure previously outlined for the removal of a shaft from the switch. The spring can then be slipped out. In reassembly, be sure the large washer in front of this spring is replaced.

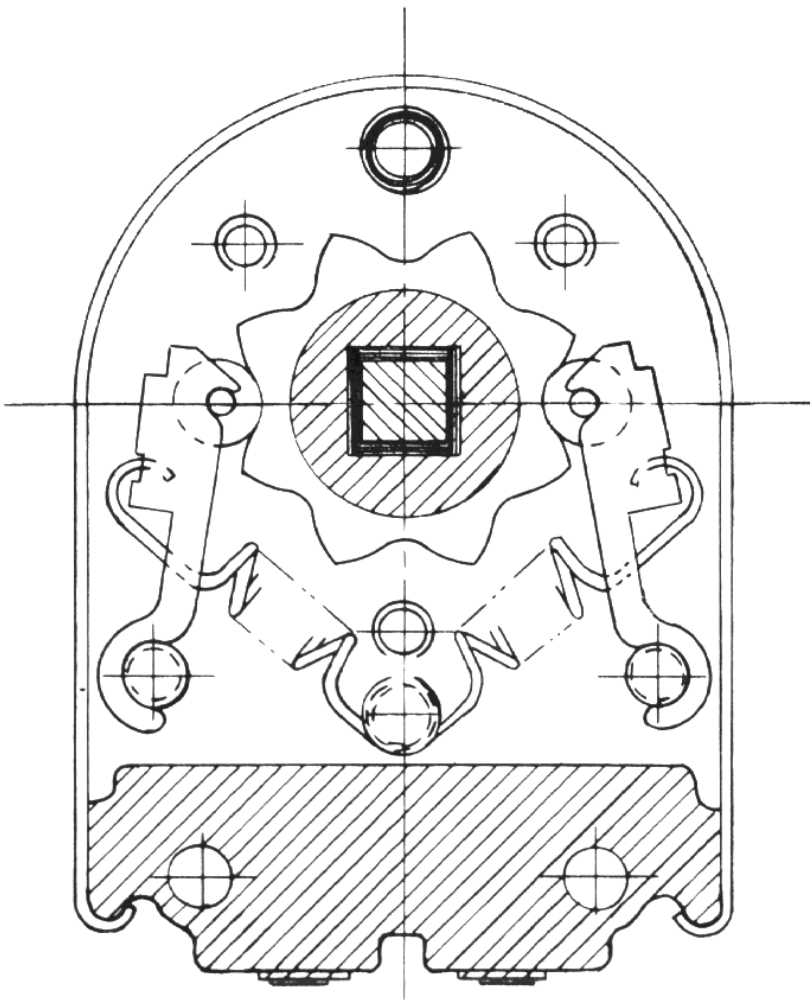

Fig. 5 - Front end plate showing star-shaped positive positioning device.

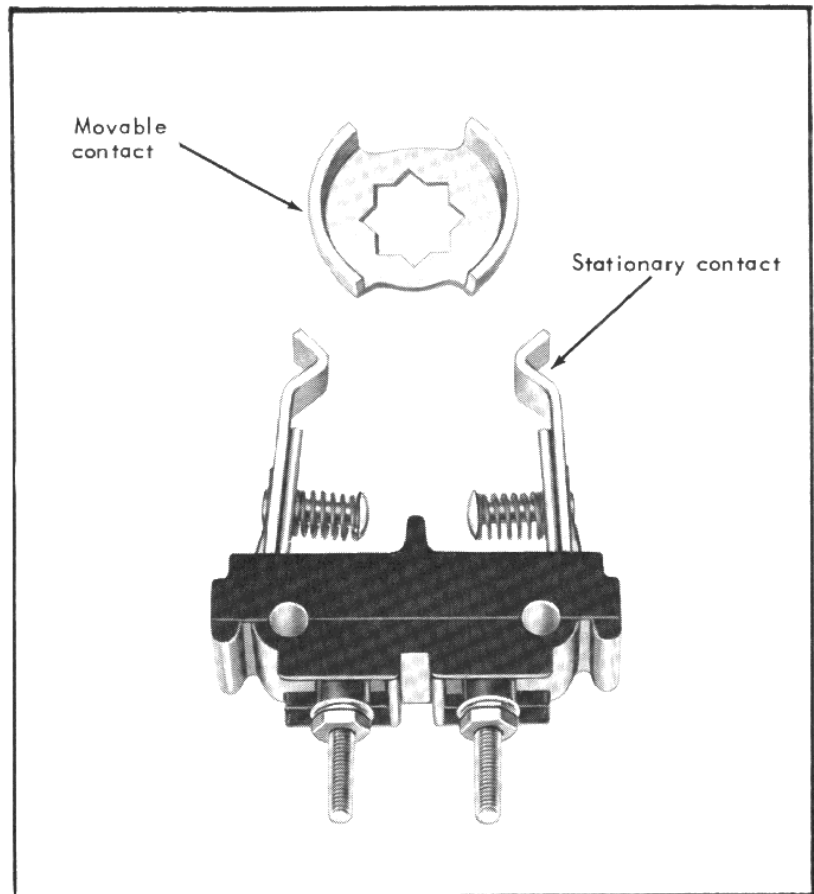

Fig. 6 - Contact stage showing unitized construction.

**Magnetic Release Mechanism:** (Fig. 10) Switches provided with this mechanism should be inspected frequently to check that the trip mechanism is mechanically free and that it will trip at the minimum voltage indicated for the magnet coil used.

#### ORDERING INFORMATION and RENEWAL PARTS

When ordering parts for Type 210 switches always give description and full nameplate information of the switch as well as the controller and device for which it is intended. Furnish the part numbers if available and the quantity of each part required.

When ordering contact segments, give the number stamped on the segment and its location on the shaft. Using the letter code shown in Figure 8 will help customer obtain the correct segments.

If special shipping instructions are necessary, explain how shipment is to be handled. When shipping instructions are not given, parts will be shipped best way.

Send your order to the nearest Allis-Chalmers Sales Office.

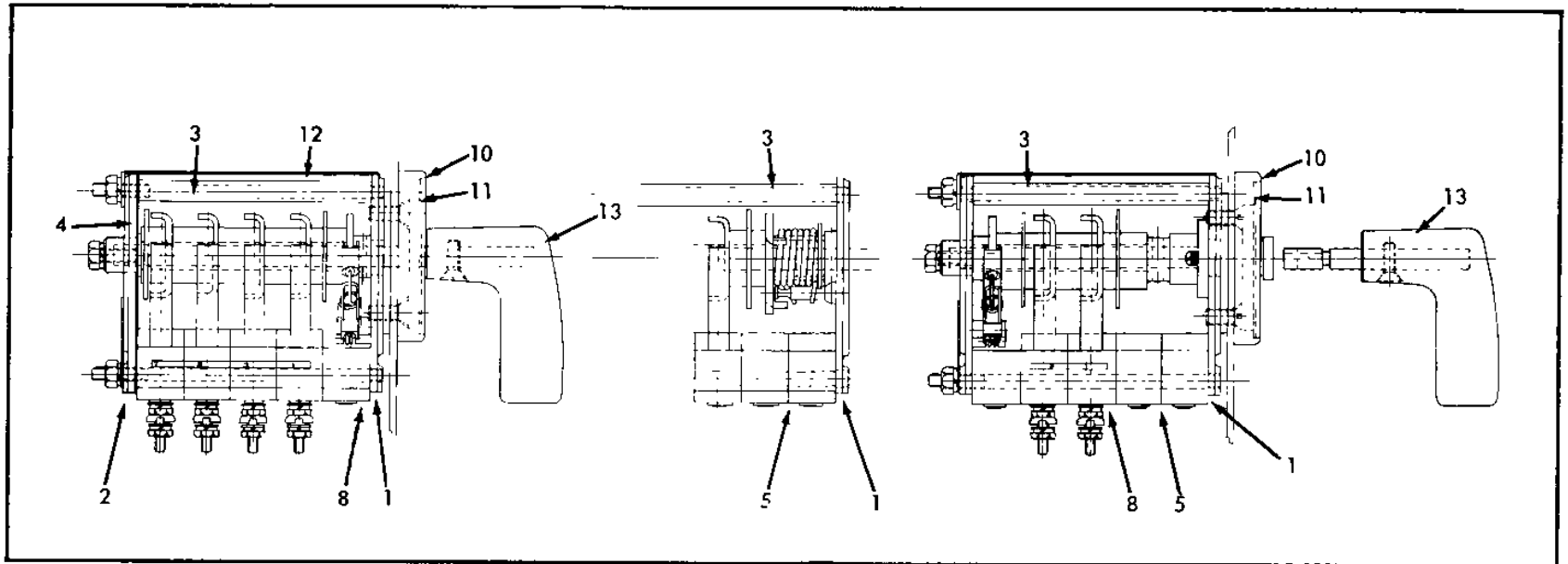

A. Handle arrangements.

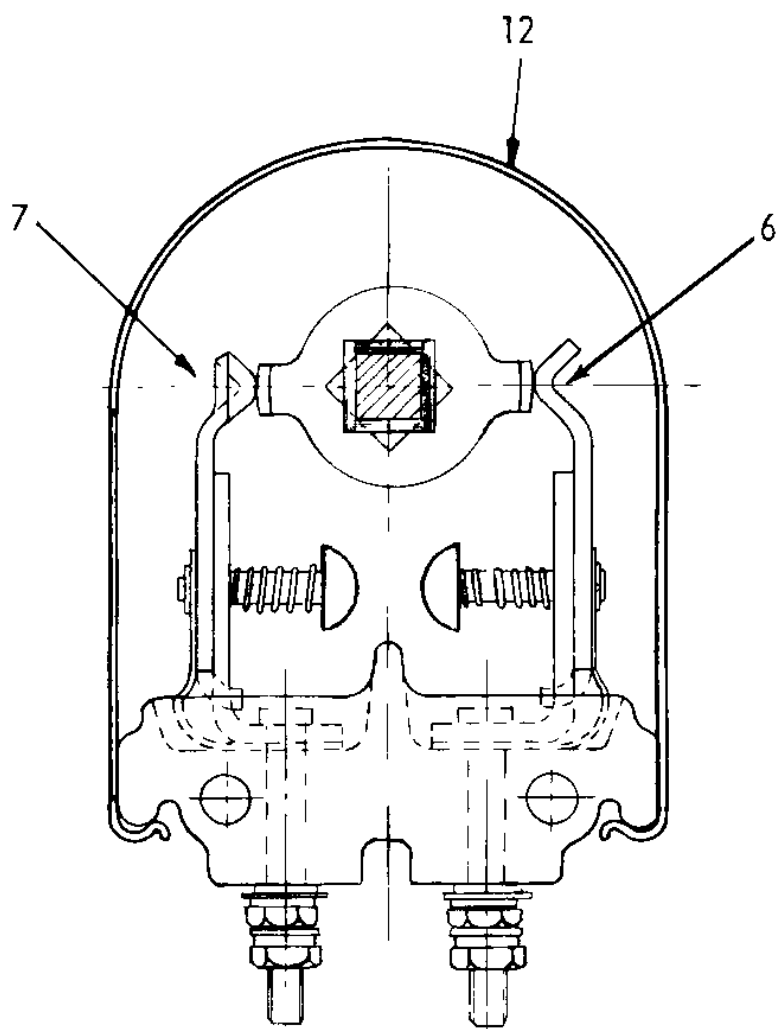

B. End view showing round and flat stationary contact fingers.

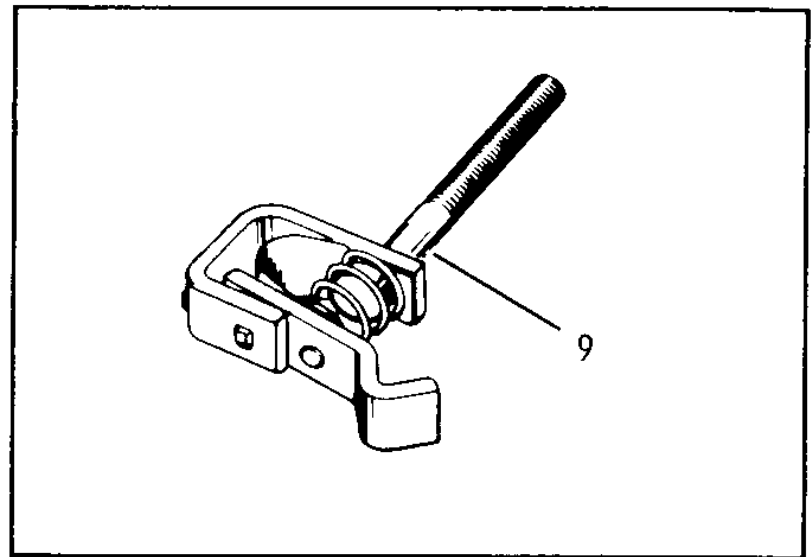

C. Standard flat upper contact used with 3 contacts per stage. For rotary switch only.

| Item No. | Description of Part                     | Quan. Req. | Part No.          |
|----------|---|------------|-------------------|
| 1        | Front end plate assembly                | 1          | *                 |
| 2        | Rear end plate assembly                 | 1          | *                 |
| 3        | Insulating tube                         | *          | *                 |
| 4        | Insulating plate                        | 1          | 14-107-608-00-001 |
| 5        | Base block                              | *          | 14-205-351-00-001 |
| ** 6     | Stationary contact assembly (std.)      | *          | 14-318-773.501    |
| ** 7     | Stationary contact assembly (round)     | *          | 14-318-773.502    |
| 8        | Positioning finger assembly (complete)  | 2          | 14-203-713-00-502 |
| 9        | Standard flat upper contact             | *          | 14-105-360-00-501 |
| 9        | Standard ball upper contact (not shown) | *          | 14-105-360-00-502 |
| 10       | Face plate                              | 1          | 14-319-700-MK-001 |
| 11       | Position plate                          | 1          | *                 |
| 12       | Cover                                   | 1          | *                 |
| 13       | Operating handle (round)                | 1          | *                 |
| 13       | Operating handle (pistol-grip)          | 1          | *                 |
| 13       | Operating handle (oval)                 | 1          | *                 |
| 13       | Removable key handle                    | 1          | *                 |

\* These parts are variable. Supply nameplate data.

\*\* These are additional parts frequently required. The necessity for stocking is dependent upon operating conditions.

Fig. 7 -- Control switch details.

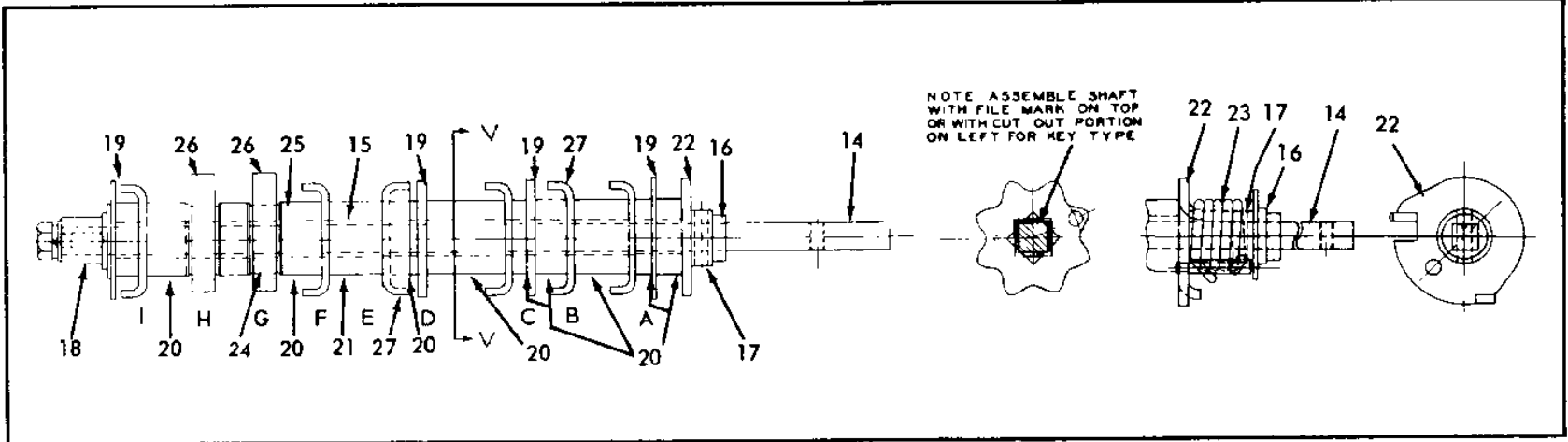
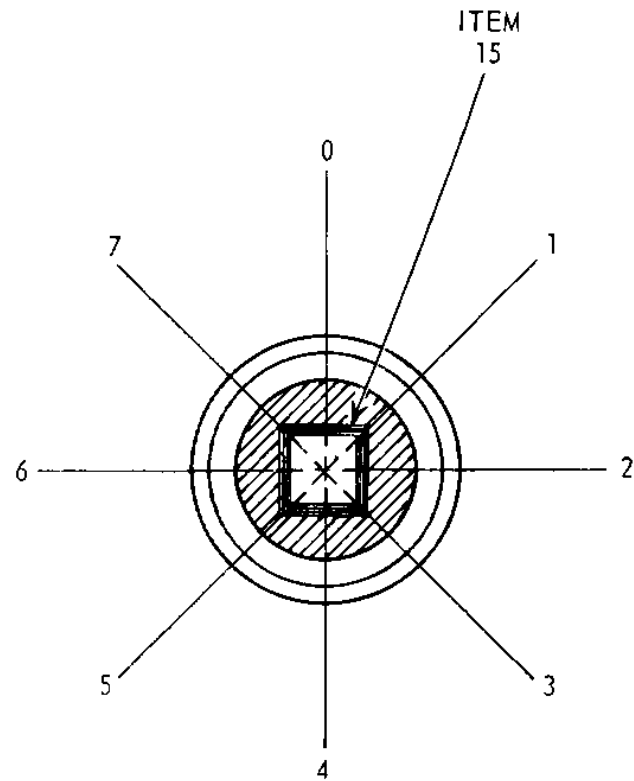

Fig. 8 - Shaft assembly.

| Item No. | Description of Part                               | Quan. Req. | Part No.          |
|----------|---|------------|-------------------|
| 14       | Shaft   | 1          | *                 |
| 15       | Shaft insulation                                  | 1          | *                 |
| 16       | Front bearing                                     | 1          | 14-137-351-00-001 |
| 16       | Front bearing for spring return switch            | 1          | 14-103-705-00-011 |
| 17       | Bearing pin                                       | 1          | *                 |
| 18       | Rear bearing                                      | 1          | 14-137-352-00-001 |
| 19       | Insulating washer (17/32-in. I.D. 1/8-in. thick)  | *          | 14-107-202-00-001 |
| 19       | Insulating washer (45/64-in. I.D. 1/8-in. thick)  | *          | 14-107-202-00-002 |
| 19       | Insulating washer (17/32-in. I.D. 1/16-in. thick) | *          | 14-107-202-00-003 |
| 19       | Insulating washer (45/64-in. I.D. 1/16-in. thick) | *          | 14-107-202-00-004 |
| 20       | Insulating bushing                                | *          | (specify length)  |
| 21       | Conductor bushing .442-in. long                   | *          | 14-107-603-00-001 |
| 21       | Conductor bushing .723-in. long                   | *          | 14-107-603-00-002 |
| 22       | Positioning wheel or stop plate                   | 1          | *                 |
| ** 23    | Return spring (for max. 45° turn)                 | 1          | 14-111-531-00-001 |
| ** 23    | Return spring (for max. 90° turn)                 | 1          | 14-128-362-00-002 |
| 24       | Bushing   | *          | 14-144-131-00-001 |
| 25       | Spacer  | *          | 14-112-045-00-501 |
| 26       | Slip contact segment                              | *          | 14-144-301        |
| 27       | Contact segment                                   | *          | *                 |

\* These parts are variable. Supply nameplate data.

\*\* These parts are most subject to wear in ordinary operation and should be stocked.



SECTION V-V

Fig. 9 - Control switch positions (numbers 0 to 7).

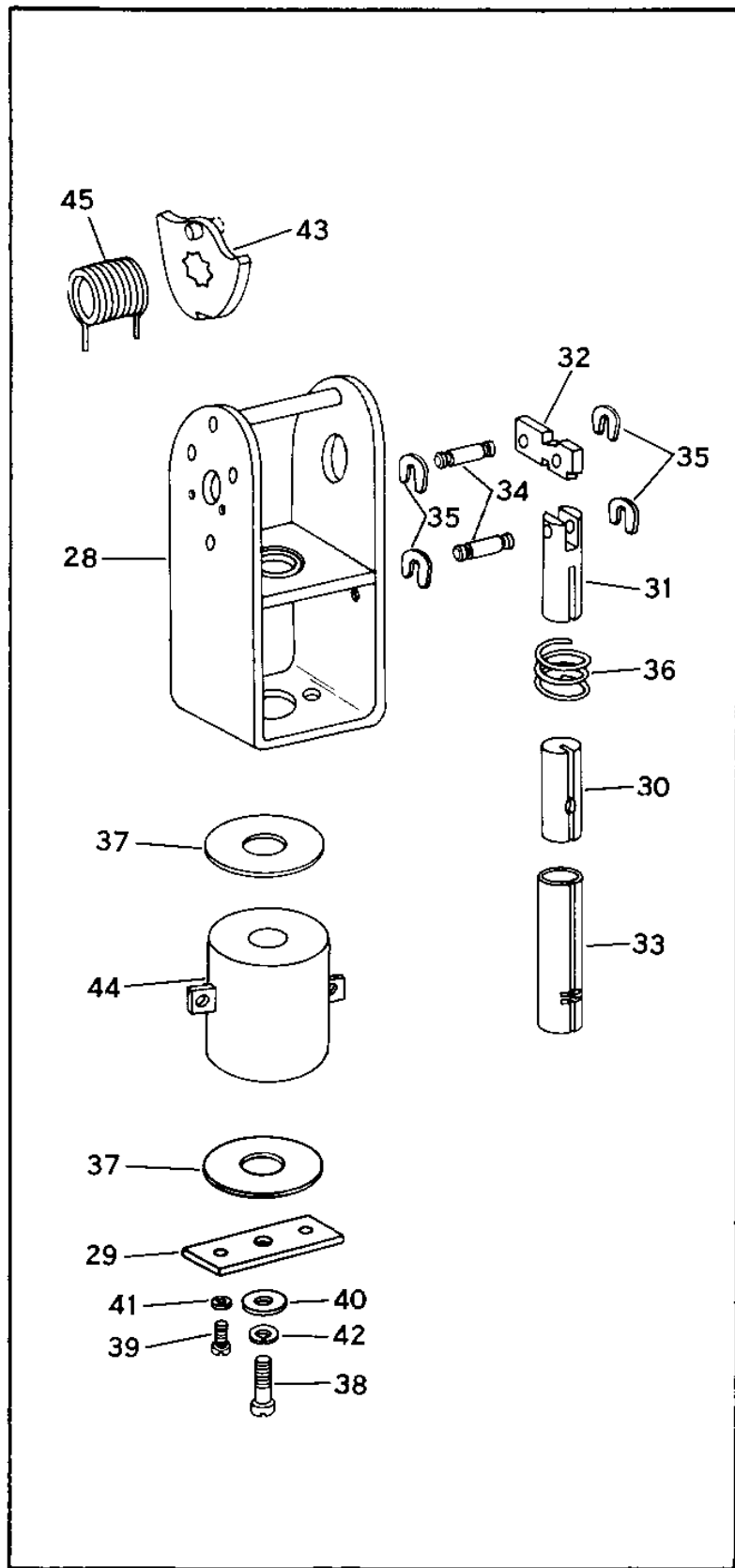

Fig. 10 - Magnetic release mechanism.

| Item No. | Description of Part  | Quan. Req. | Part No.          |
|----------|--|------------|-------------------|
| 28       | Coil support assembly for 2-contact type, left turn release  | 1          | 14-323-099-502    |
| 29       | Core support plate   | 1          | 14-137-575-00-001 |
| 30       | Magnet core  | 1          | 14-137-576-00-001 |
| 31       | Plunger  | 1          | 14-137-577-00-001 |
| 32       | Release bar  | 1          | 14-137-578-00-001 |
| 33       | Core bushing   | 1          | 14-113-511-00-001 |
| 34       | Bearing pin  | 2          | 14-127-201-021    |
| 35       | "U" washer   | 4          | 00-673-165-025    |
| 36       | Spring   | 1          | 14-141-700-001    |
| 37       | Insulating washer  | 2          | 14-113-713-00-001 |
| 38       | 1/4-in. x 20 x 3/4-in. long filister head mach. screw, steel | 1          | 00-615-223-00-375 |
| 39       | 10/32 x 3/8-in. long filister head mach. screw, steel        | 2          | 00-615-245-00-216 |
| 40       | 1/4-in. steel washer   | 1          | 00-651-007-00-160 |
| 41       | No. 10 washer, steel   | 2          | 00-655-017-00-022 |
| 42       | 1/4-in. lockwasher   | 1          | 00-655-017-00-026 |
| 43       | Stop plate assembly  | 1          | 14-137-580-00-501 |
| 44       | Magnet coil  | 1          | See Table Below   |
| 45       | Torsion spring   | 1          | 14-121-447-00-001 |

TABLE 2 - TRIP COILS

| Dc Volts | Dc Ohms | Minimum Trip Volts | Part No.          |
|----------|---------|--------------------|-------------------|
| 125-250  | 59.2    | 50.                | 14-182-237-00-502 |
| 48-125   | 14.0    | 32.                | 14-182-593-00-502 |
| 24-48    | 2.3     | 12.                | 14-182-592-00-502 |
| Ac Volts | Dc Ohms | Minimum Trip Volts | Part No.          |
| 110      | 17.5    | 70.                | 14-182-592-00-502 |
| 220      | 105.0   | 105.               | 14-182-593-00-502 |