

## TEST BLOCKS AND PLUGS TYPE PK-2

### INTRODUCTION

The Type PK-2 test blocks and plugs are used to test switchboard mounted instruments, meters, and relays when in an electric circuit or by the use of a separate source of power. They are available in either four or six poles and are back connected. The contacts have line contact.

The Type PK-2 test blocks and plugs are capable of carrying 10 amperes at 250 volts continuously. They are not intended to interrupt any current, but will satisfactorily open the circuit of a potential coil and transfer the current coil of instruments, meters, or relays.

### RECEIVING

The PK-2 test blocks and plugs are shipped in individual cartons. In the carton with the test block, unassembled in a separate container, are sufficient auxiliary contacts for any combination shown in Fig. 8 and 9. Also packed in the sep-

arate container are the nuts and washers for the studs; mounting screws, washers, and nuts for mounting the test block on steel panels; and jumpers and holding screws for the auxiliary contacts.

### INSTALLATION

#### MOUNTING

The block can be mounted on the front surface of panels 1/8 inch to 2 inches thick or on the rear surface of a panel not more than 1/8 inch thick (see Fig. 1 and 2). With both methods of mounting, the cover and test plug are inserted from the front of the panel.

Before mounting on the panel, the auxiliary

contacts should be assembled according to the combination required, as shown in Fig. 8 and 9.

Fig. 3 shows a composite assembly of all the auxiliary contacts. These are fastened as shown by the No. 4-48, 5/16 inch round-head screws which pass through the auxiliary contacts and are threaded into the inserts in the bottom of the block. Auxiliary contact (1, Fig. 3), is used to prevent circuit interruption when the cover is removed. This type

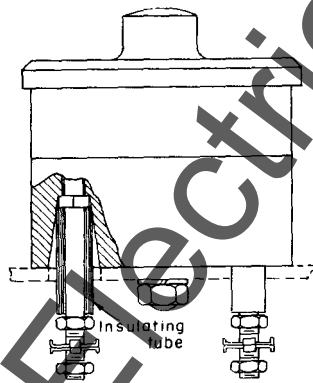

Fig. 1 Mounting on Front of Steel Panel

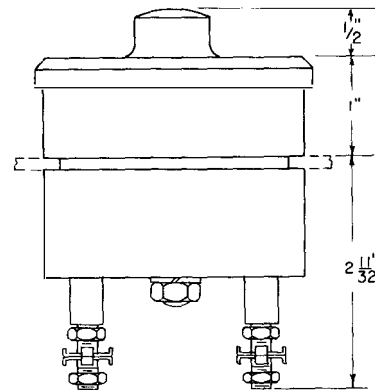

Fig. 2 Semi-Flush Mounting on 1/8-inch Steel Panel

*These instructions do not purport to cover all details or variations in equipment nor to provide for every possible contingency to be met in connection with installation, operation or maintenance. Should further information be desired or should particular problems arise which are not covered sufficiently for the purchaser's purposes, the matter should be referred to the General Electric Company.*

## GEH-1023C Type PK-2 Test Blocks and Plugs

of internal connection is shown in F, Fig. 8. Without this connection, loss of revenue is possible due to interruption of the recording-instrument reading, if replacement of the cover is long delayed. Auxiliary contacts (2 and 4, Fig. 3) are used when the current coils are to be isolated while being tested and the current-transformer secondaries are shorted. This type of internal connections is shown in B, C, D, and E, Fig. 9. The jumper (3, Fig. 3) is employed to connect two of auxiliary contacts No. 2, or one of No. 2 and one of No. 4, Fig. 3. This type of connection is shown in C and D, Fig. 8.

Drill the panel, for the size of the test block and panel mounting required, in accordance with the dimensions shown in Fig. 5.

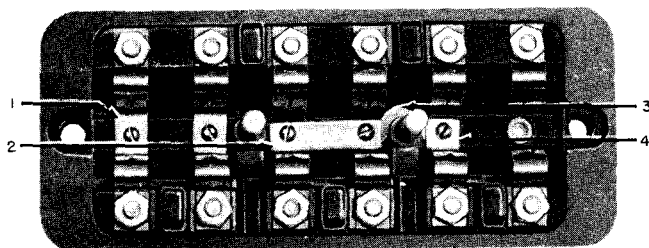

Fig. 3 Six-Pole Test Block With Jumper and Auxiliary Contacts

If the test block is mounted on an insulation panel, install it on the front of the panel and use the studs for holding it in place (see Fig. 7). If the test block is mounted on the front of steel panels, proceed in the same manner as for installation on insulation panels except, the separate mounting screws furnished for this purpose must be used. Be sure the insulation tubes are on the studs properly to provide insulation from the steel panel (see Fig. 1).

For semi-flush mounting on 1/8 inch steel panels, a different panel drilling is required, and the block is mounted on the back of the panel with the contacts extending through the panel. Use separate mounting screws furnished (see Fig. 2).

For ease of wiring and uniformity in testing, the blocks should be mounted so the long center line is horizontal on the panel and the auxiliary contacts and interlocking slots are down.

### CONNECTIONS

Each block is essentially a multi-pole jack. When the cover is removed, the device to be tested is isolated. When current transformers are used, the secondaries are short-circuited automatically by auxiliary contacts (see Fig. 7, 8 and 9).

Schematic wiring diagrams are shown in Figs. 10 to 16 inclusive.

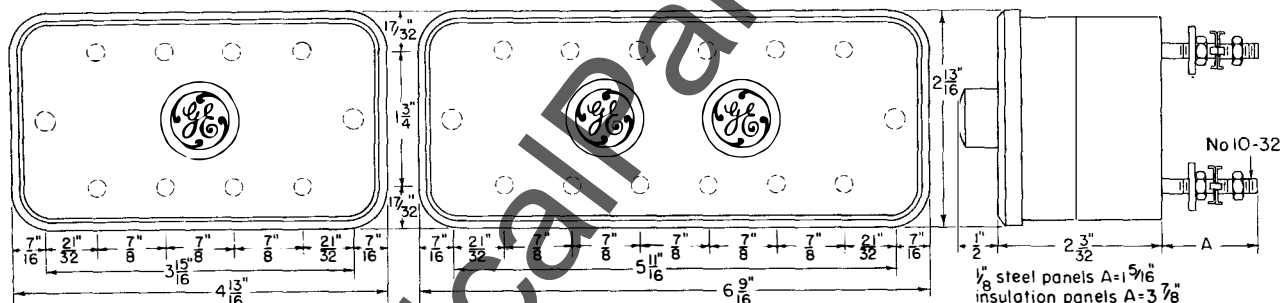

Fig. 4 Outline Dimensions of Four-Pole and Six-Pole Test Blocks

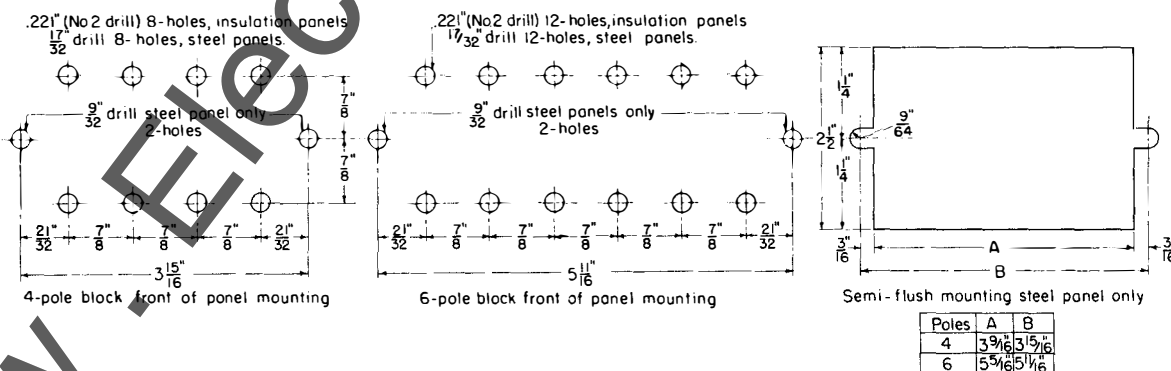

Fig. 5 Panel-Drilling Dimensions of Four-Pole and Six-Pole Test Blocks

The purpose of the test plug is to facilitate routine check testing. They can be permanently connected to any testing equipment. Insertion of a plug in the test block isolates the auxiliary contacts, when used, and establishes test connections (see Fig. 7). Links or jumpers are provided (see Fig. 6) to facilitate making connections. The test blocks have guide rods and interlocking slots so the cover and plug must be inserted squarely, and in the same position every time. Holes are provided in the guide rods and cover through which seal wires may be threaded to prevent unauthorized removal of the cover from the test blocks.

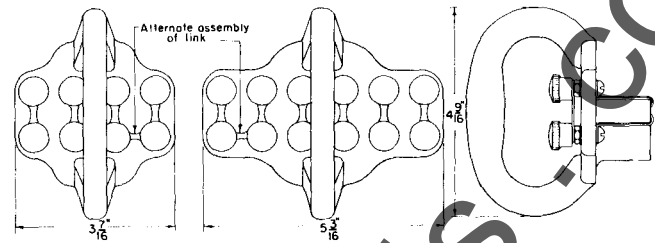
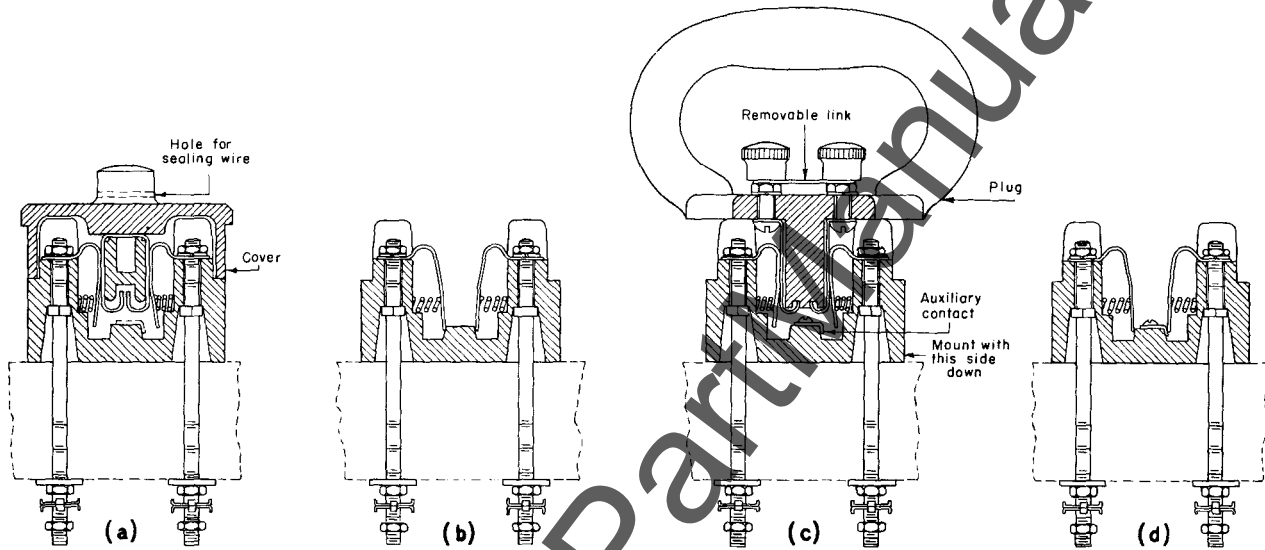

Fig. 6 Alternative Link for Four-Pole and Six-Pole Plugs



This illustration shows a schematic sectional view of the test-block cover and plug. (a) With cover in place and the plug contact in the cover making a connection through the block and removing the short circuit by the auxiliary contact. (b) With cover and plug removed, used for circuit in which there is no current transformer. (c) With the plug inserted and the plug contacts removing the short circuit by the auxiliary contact. (d) With cover and plug removed and with auxiliary contact short-circuiting the transformer secondary.

Fig. 7 Schematic Sectional Views of Test Blocks

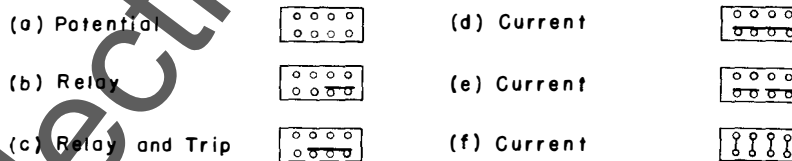

Fig. 8 Internal Connections of Four-Pole Block

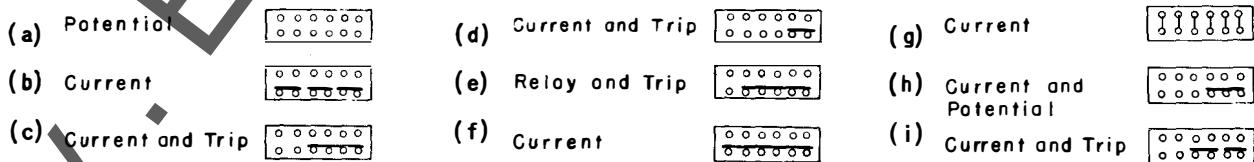

Fig. 9 Internal Connections of Six-Pole Block

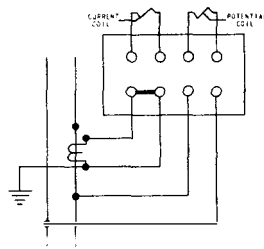

Fig. 10 Back-View Connection of Test Block for One Current and One Potential Coil

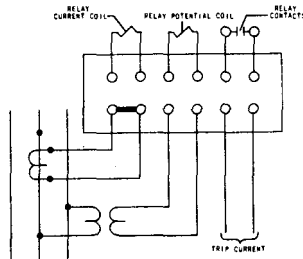

Fig. 11 Test-Block for One Current and One Potential Coil With Connections for Trip Circuit

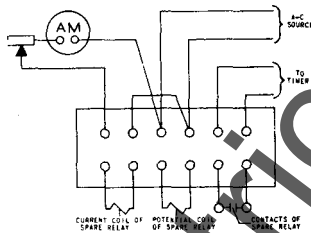

Fig. 12 Plug Connection for Fig. 11 for Separate Test of Relay With Separate Source and Spare Relay for Protection While Testing

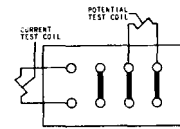

Fig. 13 Back-View Connection of Plug for Testing One Current and One Potential Coil In Circuit

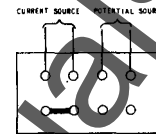

Fig. 14 Back-View Connection of Plug for Testing One Current and One Potential Coil With Separate Source

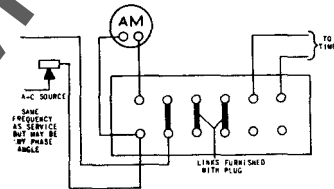

Fig. 15 Plug Connections for Fig. 11 for Testing Relay With Same or Separate Source

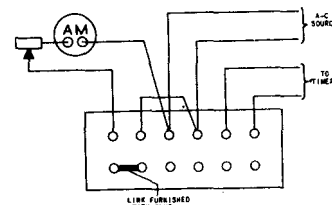

Fig. 16 Plug Connection for Fig. 11 for Separate Test of Relay With Separate Source

## OPERATION

Permanent connection of the plug to the test equipment is recommended. With the plugs properly connected, there is little chance of er-

ror in testing as it is a matter of removing the cover of the block and inserting the proper test plug.

## RENEWAL PARTS

When ordering renewal parts, address the nearest General Electric Sales Office, specify the quantity required, give the catalog number or describe

the required part, and give the complete data from the nameplate.

APPARATUS DEPARTMENT, GENERAL ELECTRIC COMPANY, SCHENECTADY, N. Y.

Com

Fig. 11 (K-6496740)

Fig. 13 (K-6496742)

Fig. 15 (K-6496744)