



**INSTRUCTIONS  
AND  
RENEWAL PARTS**

**GEI-88767D**  
Supersedes GEI-88767C

# LOAD BREAK SWITCH

**SE-100 E**  
**SE-100 M**  
**SE-100 S**

## CONTENTS

Introduction.....	1
Ratings.....	1
Receiving, Handling and Storage.....	2
Installation.....	3
Description of Operation..	
SE-100E & SE-100S.....	4
SE-100M.....	11
Adjustments	
SE-100E & SE-100S.....	5
SE-100M.....	22
Final Inspection.....	13
Renewal Parts.....	15
Lubrication Chart.....	16
Schematic Wiring Diagram	
SE-100E.....	16

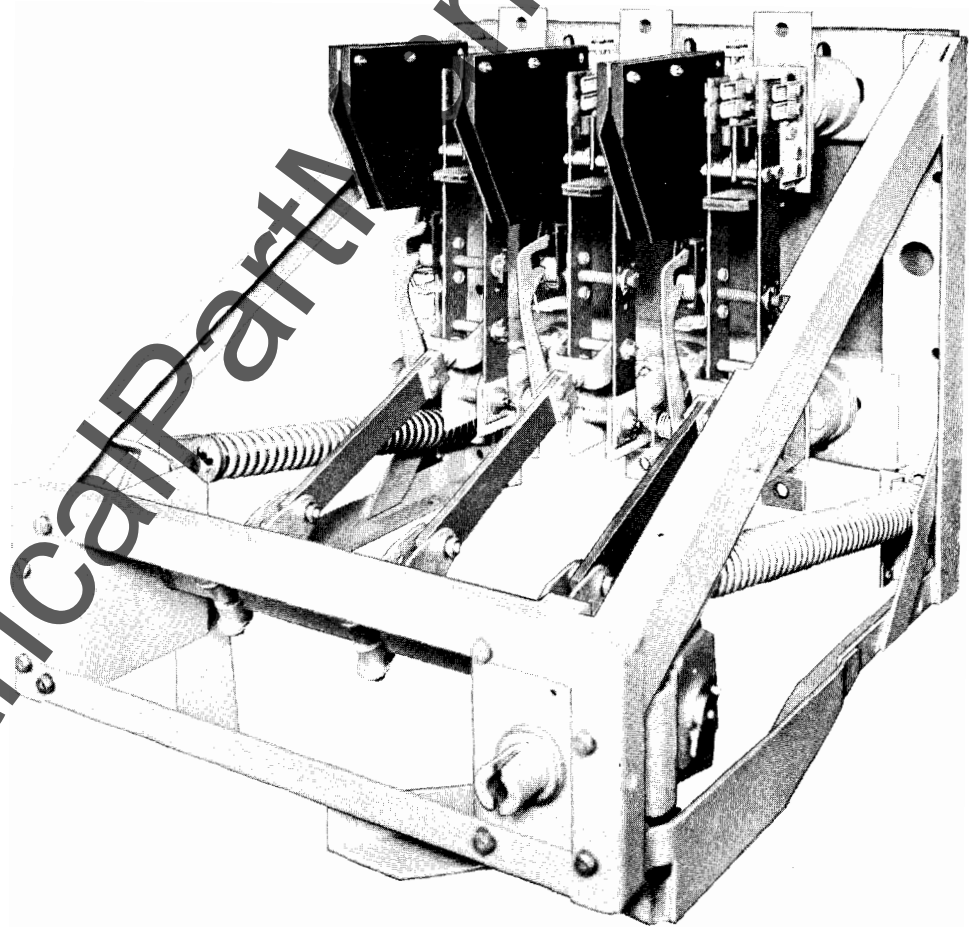

**SWITCHGEAR PRODUCTS DEPARTMENT**

**GENERAL  ELECTRIC**

**PHILADELPHIA, PA.**

LOAD BREAK SWITCHTYPE SE-100INTRODUCTION

The type SE-100 Load Break Switch is manually or electrically operated, triple pole disconnecting switch with an integral interrupter that has capability of interrupting transformer magnetizing and load currents within its rating.

The SE-100S has a manually charged, spring stored energy operating mechanism capable of closing the switch against maximum rated short circuited current.

The SE-100E has an electrically charged, spring stored energy operating mechanism with the same closing capabilities as the SE-100S.

The SE-100M is a manually closed and opened switch with load break abilities as indicated on the nameplate.

Refer to the nameplate for complete ratings of any particular switch. Do not apply the switch for any duty where voltage or current levels are greater than those given on the nameplate. The chart below gives the ratings for the basic switches.

SE-100 Switch Ratings

	Nominal Voltage KV	Max.Design Voltage KV	BIL KV	Continuous Current Amps	Load Break Current Amps	Close & Latch Current Amps	Momentary Current KA
SE-100E SE-100S	4.8	5.5	60	600	600	40,000	40
	4.8	5.5	60	1200	1200	61,000	61
	13.2	15.5	95	600	600	40,000	40
	13.2	15.5	95	1200	600	61,000	61
SE-100M	4.8	5.5	60	600	400	400	40
	13.2	15.5	95	600	100	100	40

These instructions do not purport to cover all details or variations in equipment nor to provide for every possible contingency to be met in connection with installation, operating or maintenance. Should further information be desired or should particular problems arise which are not covered sufficiently for the purchaser's purposes, the matter should be referred to the General Electric Company.

The switch is normally furnished with outside and interphase insulating barriers in a metal-enclosed housing for connection either directly to

the incoming side of a power transformer, the primary bus, or to cables by the use of potheads. When applied with power fuses, the combination serves as a successful switching and fault protection device.

Operation of the switch is accomplished by manual rotation of a handle through an arc of  $180^{\circ}$ . The SE-100S switch has a positive closing and opening operation supplied from the stored energy of springs. The SE-100M handle must be operated manually with a full positive motion to assure proper closing and opening with the direct drive mechanism. The operating handle is often interlocked with other devices such as secondary circuit breakers in order to assure sequential operation.

The SE-100E switch is normally operated by energizing an integral electric motor that charges the springs for positive closing and opening similar to the handle of the SE-100S. The switch can be quickly converted from electrical to manual operation with a handle for normal maintenance or emergency use.

The interrupting ability of the switch is accomplished by the use of an arc chute type interrupter (5) Fig. 4 and an auxiliary blade (3). When the switch is opened the auxiliary blade contacts (2 & 3) are the last to part and will initiate an arc in the chute. The hot arc releases gases from the plastic chute in such volume that the arc is blown away from the rapidly moving auxiliary blade and cooled by contact with the large area of the chute sides. After the arc has been extinguished, the blade will continue to open producing a sufficient air gap to isolate the terminals.

## RECEIVING, HANDLING, AND STORAGE

### Receiving and Handling

Immediately upon receipt of the switch, an examination should be made for loss or damage sustained in transit. If injury or rough handling is evident, a damage claim should be filed immediately with the transportation company and the nearest General Electric Apparatus Sales Office should be notified.

Although damage due to handling is minimized because of the metal enclosure, it is expected that due care will be exercised in the unpacking and installation of the switch unit so that no damage will occur from careless or rough handling, or from exposure to moisture or dirt. Care should be exercised to prevent tools from striking any part of the housing or switch itself.

Loose parts associated with the switch are always included in the same crate. Check all parts against the packing list to be sure that no parts have been overlooked.

### Storage

It is recommended that the switch be placed into service immediately in its permanent location. If this is not possible, the following precautions should be taken to insure proper storage conditions:

1. The switch should be stored in a warm dry location to protect the insulation parts from condensation.
2. The switch should be stored in a clean location free from corrosive gases or fumes. Particular care should be taken to protect the equipment from moisture and cement dust, as this combination has a very corrosive effect on many parts.
3. Machined parts of the operating mechanism should be coated with a heavy oil or grease to prevent rusting.

If the switch is stored for long periods of time, periodic inspections should be made to insure that corrosion of metallic parts or deterioration of insulation parts has not begun. Should the switch be stored under unfavorable conditions, steps should be taken to dry out or replace insulation parts before placing in service.

## INSTALLATION

### Mounting

The switch must be mounted in the housing by supporting at both the front and rear. Care should be taken not to distort the frame by mounting on unflat or out-of-square surfaces as twisting may cause misalignment of the contacts. If necessary, shims should be used to prevent twisting.

### Connection

The connections on the 600 ampere switch may be made from above or below the insulator support. The 1200 ampere switch must have the upper connections above the upper insulator support and the lower connection below the hinge support insulator. Connection of bus bars to this terminal can easily be made using the provided terminal bolts. After connections to the switch have been made, the switch alignment should be checked as listed below.

When furnished as a complete housing, the connections directly to the switch have been made at the factory. On these units, connections are made using the provided potheads, cable terminal connectors, etc.

### Switch Alignment

Prior to placing the switch in service the following adjustments and alignment checks should be made to insure proper operation.

1. Before operating the SE-100E or SE-100S switch with the normal spring load, a slow closing of the blades should be made to check alignment. The power springs should be blocked as described under Spring Blocking and the three poles of the switch operated slowly by the maintenance handle to assure freedom of motion and to check alignment. A slow closing operation can be made on the SE-100M switch with the normal operating handle.

2. Check all items listed under Adjustments before the switch is put in operation and during each period of maintenance.

### DESCRIPTION OF OPERATION SE-100E AND SE-100S

On the SE-100E and SE-100S switches both the closing and opening operation is accomplished by the spring-charged mechanism (6) Fig. 1 located on the front of the switch assembly. The mechanism is manually or electrically charged but is completely disengaged from the operating handle as it begins to operate the switch. In this way the actual operation of the switch is independent of the operator.

When operating either switch manually, the handle should be rotated with a positive motion throughout its entire stroke.

#### Closing Operation

Closing the SE-100S switch, and the SE-100E switch set for manual operation, is accomplished by inserting the operating handle (1) Fig. 3 into the handle socket provided in the operating hub (7) Fig. 1 in the enclosure and rotating in a counterclockwise direction as far as possible (approximately 180 degrees).

After a few degrees of handle rotation, the mechanism will engage the primary spring (4) Fig. 1 located on the right side and compress it fully. Continued rotation of the handle will push the spring over the toggle position and it will start to discharge. A driving lug (5) Fig. 2 will engage the drive crank (3), which is directly connected to the main crank shaft (11) Fig. 2, just as the primary spring leaves the toggle position. When the main crank shaft has rotated a few degrees, the fully charged booster spring, located on the left side, (5) Fig. 1 will pass its toggle position and the full energy of both springs will close the switch with sufficient force to close and latch against the current rating on the nameplate.

During the closing operation the auxiliary blade will be held out of the chute until just before the arcing contacts (6) Fig. 7 are engaged, then it is released to enter the chute and latch into the arc chute contacts (2) Fig. 4. This sequence of operations will prevent pre-strike in the interrupting area of the arc chute.

At any time during the operation, until the primary spring reaches its toggle position, the handle can be returned to its starting position and removed. The mechanism will completely reset to the starting position.

The SE-100E switch is normally electrically operated by energizing a motor (2) Fig. 10. An internal gear driving mechanism will charge the springs and operate the switch in the same manner as the mechanical handle drive.

When the closing switch contacts are made the start-stop relay (3) Fig. 10 will close contacts and energize the motor in the proper direction. At the same time a closing seal-in relay (4) assures a complete operation without hesitation and makes the closing of the SE-100E switch independent of the operator. During the closing operation an auxiliary switch (1) will open the motor circuit and arrange a series of contacts for an opening operation. It will also de-energize the start-stop relay that will close a set of contacts in the motor circuit, shunting the field coils around the armature, thereby effecting a dynamic brake. Refer to wiring diagram Fig. 12.

### Opening Operation

To open the SE-100S switch, and the SE-100E switch set for manual operation, the operating handle is inserted into the handle socket and rotated in a clockwise direction as far as possible (approximately 180°).

After a few degrees of handle rotation, the mechanism will engage the primary spring (4) Fig. 1 and compress it fully. Continued handle rotation will push the spring over the toggle position and it will start to discharge. A driving lug (5) Fig. 2 will engage the drive crank (3) at the toggle position of the primary spring and will turn the main crank shaft (11). When the main crank shaft has rotated a few degrees past the primary spring toggle position, the spring will discharge, opening the switch, and charging the booster spring (5) Fig. 1 for the next closing operation.

The primary blade (11) Fig. 7 travel will cause the primary contacts (5) to part first and the arcing contacts (6) a few degrees later. The spring loaded auxiliary blade (3) Fig. 4 will remain latched to the contacts (2) inside the arc chute. At a predetermined position of the primary blades, the auxiliary blade will be released and will snap open at a high velocity.

As the arc chute contacts part, an arc is established between the auxiliary blade tip (3) Fig. 4 and the finger contacts (2). The hot arc releases gases from the plastic arc chute material dispersing the arc over a large area of the chute sides. The rapidly cooled arc is extinguished in the chute and the auxiliary blade will continue to travel until a sufficient air gap is achieved to withstand BIL voltages.

The SE-100E switch when opened electrically by the motor drive will have the same sequence of operations as when the manual handle is used. The electrical sequence is the same as described in the closing operation except seal-in relay (5) Fig. 10 is used.

### ADJUSTMENTS SE-100E AND SE-100S

#### Spring Blocking

For most of the adjustments it will be necessary to operate the switch slowly with the maintenance handle. To do this the power springs must be blocked using the following procedure. Refer to Fig. 2.

1. Remove the rear bolt from position (1A) of the spring stop (2) located on the upper right angle frame. On 1200A switches it may be necessary to loosen the front bolts of the right hand barrier to have access to the bolts.
2. Rotate the stop until it is vertical, replace the bolt that had been removed in the lower location (1) and tighten.
3. The SE-100E mechanism must be put into the manual operation condition before operating with the manual handle. Disengage the electrical operator by sliding the yellow pawl block toward the center hub using a screw driver or other small tool Fig. 10. When the switch is closed the pawl will appear in the left hole, when open the right hole.
4. Using the normal operating handle rotate in a counterclockwise direction (direction of close) until the spring yoke on the right contacts the stop.
5. Remove operating handle and insert maintenance handle (2) Fig. 3 on main square shaft and screw the blocking pins (3) Fig. 3 in the left and right spring guide at (4) Fig. 2. The springs are now safely blocked and the maintenance handle will open and close the switch for adjusting purposes.

#### Upper (Closed) Mechanism Stop

The upper buffer stops (3) Fig. 5 located on either side of the mechanism at the ends of the main crank shaft, must be adjusted to position the operating rod cranks when the switch is closed. Operate the switch to the fully closed position.

The operating rod must go over toggle approximately  $\frac{1}{4}$ " at the crank connection when the switch is closed. A simple means of measuring the correct toggle angle is to place a straight edge along the upper side of the operating rod and extend it until it is over the square main shaft (10) Fig. 6. The dimension from the straight edge to the closest corner of the square shaft should be  $\frac{1}{4}$ " to  $\frac{3}{8}$ ".

If adjustment of the stop is necessary, remove the cotter pin holding the stop (3) Fig. 5 and move washers and metal shims from the front to the rear (or the reverse) until the proper toggle angle is obtained. Adjust the stops at both ends of the main shaft the same amount to keep them balanced.

#### Primary Wipe

The operating rod must fully close the switch primary blades to obtain the correct primary finger wipe.

With the switch in the closed position, pull the top of the primary blades to the front with your hands to remove connection clearances. There should be  $\frac{1}{64}$ " to  $\frac{1}{32}$ " clearance between the buffer (8) Fig. 7

and the primary blade buffer stop (1) Fig. 1. There should also be  $3/16$ " to  $1/4$ " between the edge of the primary blade and the front of the primary contact support.

Adjust the length of the rod by use of the adjusting nuts (6) Fig. 6 to obtain the  $3/16$ " to  $1/4$ " gap then adjust the buffer (8) Fig. 7 by adding or removing shims to get the  $1/64$ " to  $1/32$ " clearance.

#### Primary Gap

The primary gap should be measured with the primary blades in the normal position. A measurement should be made from the buffer stop or spacer (3) Fig. 9 to the primary finger (2). The same primary finger, the bottom finger, should be used on both 600A and 1200A switches. The dimension should be 11" plus or minus  $3/8$ ". If this dimension is not correct, the lower buffer stop (6) Fig. 5 should be adjusted in a similar manner to the adjustment on the upper stop. Move shims and washers from the top to the bottom of the stop (or the reverse) as required. Adjust the stops at both ends of the main shaft the same amount to keep them balanced.

#### Primary and Arcing Contact Alignment

Close the primary blades (12) Fig. 8 slowly by the use of the maintenance handle and note the engagement of the primary contacts (4), arcing contacts (6 & 8), and guide block (10). The blades should center around the guide block without bearing heavily on either side. They should also be centered in the primary and arcing contact fingers.

If the blades press hard against the sides of the guide block, loosen the (2) bolts (11) Fig. 8 holding the block. Again check the contact alignment. If the contacts are properly aligned, reposition the guide block and bolt securely.

If the contacts are not in alignment, loosen the bolts holding the top insulator and position the insulator to center the contacts. After securing the insulators, reposition the guide blocks and tighten the bolts.

Be certain the insulator is moved only in a horizontal direction. Vertical displacement may cause misalignment of the auxiliary blade contacts.

#### Arc Chute Alignment

The arc chute must be positioned to allow entry of the auxiliary blade; to latch, and finally, to release the auxiliary blade at the proper time.

With the operating springs blocked, turn the contact arm (12) Fig. 7 slowly closed and check the entry of the auxiliary blade (7) into the arc chute (1). The blade should enter smoothly and be in the center of the opening. If the blade scrapes heavily on the sides of the chute, loosen the (2) bolts at the top (2) Fig. 7 and the (2) bolts

(10) Fig. 7 at the bottom of the chute. Position the chute so that the blade will travel the full length without binding or heavy scraping, and tighten the bolts.

A dimension of 1-1/6" should be maintained from the rear edge of the arc chute to the front edge of the primary finger contact support at all times when moving or re-aligning the chute. Refer to Fig. 7. The auxiliary blade contacts (2) Fig. 4 inside the chute should be properly positioned to latch the auxiliary blade when this dimension is maintained.

The auxiliary blade must be released by the contacts when the primary blade has been opened to a predetermined gap. With the operating springs blocked, open the primary contacts and slowly move the primary blade until the auxiliary blade is released. At the point of release the gap from the lower edge of the primary finger (the bottom finger (2) Fig. 9 to the buffer stop or spacer (3) should be 4-7/8" to 5-3/8" on the 4.8KV and 7-1/8" to 7-3/4" on the 13.2 KV switch. If the gap is not correct the vertical location of the chute must be changed. For gaps greater than the above range, the chute must be lowered, for gaps that are less the chute must be raised. To adjust the chute, remove the upper and lower mounting bolts (2 & 10) Fig. 7. Move shims (3) from the bottom to the top of the support to decrease the gap. To increase the gap, move some of the top shims to the bottom support.

When the release gap is properly set, check again the dimension from the back edge of the chute to the primary contact finger support and the alignment of the auxiliary blade in the chute opening.

#### Auxiliary Blade Release

The auxiliary blade release hook (14) Fig. 7 should be adjusted to hold the blade out of the arc chute until a predetermined position in the closing operation.

Close the switch slowly with the maintenance handle and note the position of the primary blades when the auxiliary blade is released by the hook. The hook should be adjusted by setting the camming screw (8) Fig. 4 to release the auxiliary blade within the range of 1/2" before Primary contacts touch. After adjustment is made the lock nut (9) Fig. 4 should be tightened.

#### Primary Contact Pressure

The primary finger pressure has been adjusted at the factory to be 12 pounds per contact on the 600A switch and 24 pounds per contact on the 1200A. This can be measured with a pull scale exerting a pressure against the contact surface. The contact pressure of each finger (5) Fig. 7 should be measured individually. Increase or decrease the contact pressure by loosening or tightening the contact bolts (4) Fig. 7.

#### Arcing Finger Contact Pressure

The arcing finger contact pressure should be 12 pounds on all 600A and 16 pounds on all 1200A switches. This pressure can again be measured

with a spring scale against the contact surface. Loosen or tighten the contact bolts (7) Fig. 8 as necessary.

#### Primary Blade Hinge Pressure

The correct hinge pressure is essential for proper operation of the switch. The hinge pressure is difficult to measure, but a required torque to move the primary blades can be easily measured and can be substituted for a pressure measurement. The break away torque of the hinge (the torque required to start the blades moving) should be between 60 pound-inches to 90 pound-inches on 600A and 85 pound-inches to 110 pound-inches on 1200A switches. This can be measured by pulling at the buffer stop or spacer (1) Fig. 1 on the primary blade with a spring scale without the primary contacts, arcing contacts, and auxiliary blade contacts engaged. The scale reading should be  $5\frac{1}{2}$  to  $8\frac{1}{4}$  # on 600A and 8 to 10 # on 1200A switches. If adjustment is necessary, remove a cotter pin from either side of the hinge pin (16) Fig. 7 and tighten or loosen the nut as required. Move the nut in increments of one sixth of a turn to assure line-up of cotter pin hole and slot in the nut.

#### Control Power Check SE-100E

After the switch has been opened and closed several times with the maintenance closing handle and all adjustments have been checked as described, the operating voltage should be checked at the motor terminal board. For electrical operation of the mechanism, the control power may be either an alternating or direct current source. The nominal range for the closing and opening voltages are given on the motor nameplate. The following ranges are standard.

Nominal Voltage	Closing and Opening Voltage Range
125V d-c	90 - 130V d-c
250V d-c	180 - 260V d-c
115V a-c	95 - 125V a-c
230V a-c	190 - 250V a-c

#### Auxiliary Switch

The auxiliary switch (1) Fig. 10 is mounted in the mechanism area and is operated by several links from the main shaft. The switch consists of "a" contacts that are open when the SE-100E switch is open and "b" contacts that are open when the SE-100E switch is closed. The contacts are used for relay operation and setting up the motor circuits for close and open operations. Several "a" and "b" contacts are available for special applications by the customer.

LUBRICATION

In order to maintain reliable operation, it is important that all parts of the mechanism be properly lubricated at all times. All bearings and other parts of the mechanism subjected to wear have been properly lubricated, during assembly at the factory, using the finest grades of lubricants available. However, even the finest oils and greases have a tendency to oxidize with age, as evidenced by hardening and darkening in color. Elimination of the hardened lubricant is essential for the proper operation of the switch. Also frequent operation of the device causes the lubricant to be forced out from between the bearing surfaces. A simple lubrication will often clear up minor disturbances which might be mistaken for more serious trouble.

A definite lubrication schedule should be set up taking into consideration the frequency of operation of the switch and local conditions. Until such a schedule is worked out, the switch should be lubricated at each periodic inspection and also whenever it is overhauled, in accordance with the lubrication chart, Fig. (11). It is also recommended that the device be operated at regular intervals to insure the user that the equipment is operating freely.

The lubrication chart, Fig. (11) is divided into two methods of lubrication. The first method outlines the maintenance lubrication which should be performed at the time of periodic maintenance, and requires no disassembly. The second method outlines a lubrication procedure similar to that performed on the device at the factory, but should be used only in case of a general overhaul or disassembly for other reasons.

General Electric Lubricants D50H15 and D50H47 are available in 1/4# collapsible tubes. It is so packaged to insure cleanliness and to prevent oxidation.

Method of Cleaning Bearings

Whenever cleaning is required, the bearings should be placed in a container of clean petroleum solvent or similar cleaner. DO NOT USE CARBON TETRACHLORIDE. If the grease in the bearings has become badly oxidized, it may be necessary to use alcohol (type used for thinning shellac) to remove it. Ordinarily, by agitating the bearings in the cleaning solution, and using a stiff brush to remove the solid particles, the bearings can be satisfactorily cleaned. Do not handle the bearings with bare hands as deposits from the skin onto the bearings are inductive to corrosion. If the bearings are touched, the contamination can be removed by washing in alcohol. After the bearings have been thoroughly cleaned, spin them in clean new light machine oil until the cleaner or solvent is entirely removed. Allow this oil to drain off and then repack them immediately with G-E lubricant D50H15 being sure all metal parts are greased.

NOTE: If it becomes necessary to clean the bearings in alcohol (shellac thinner), be sure the alcohol is perfectly clean, and do not allow the bearings to remain in the alcohol more than a few hours. If it is desir-

able to leave the bearings in the alcohol for a longer time, an inhibited alcohol such as is used for anti-freeze should be used. Even then the bearings should be removed from the alcohol within twenty-four hours. Esso Anti-Freeze and Du Pont Zerone are satisfactory for this purpose. Precautions against the toxic effects of the alcohol must be exercised by wearing rubber gloves and by using the alcohol in a well ventilated room; excessive exposure to the fumes is sometimes unpleasant to personnel. Washing the bearings in the light oil and draining should follow immediately, then apply the lubricant.

The hinge of the primary contact arm (16) Fig. 7 should be disassembled cleaned, and lubricated with G.E. D50H47 lubricant at general overhaul periods. A thin film of G.E. D50H47 should also be applied to the silvered area of the primary contact arm where it enters the primary fingers (5) Fig. 7, and the arcing contact blade where it enters the arcing contact fingers (6) Fig. 7.

NOTE: Do not grease auxiliary blade (7) Fig. 7.

#### DESCRIPTION OF OPERATION SE-100M

The SE-100M switch has a direct mechanical drive and the closing and opening energy is supplied by the operator.

When operating the switch, the handle should be rotated with a positive motion throughout its entire stroke.

#### Closing Operation

Closing the switch is accomplished by inserting the operating handle (1) Fig. 3 into the handle socket provided in the operating hub (7) Fig. 1 in the enclosure and rotating in a counterclockwise direction as far as possible (approximately 180°).

During the closing cycle the auxiliary blade (7) Fig. 7 will be held out of the arc chute until the primary blades (11) are almost closed. Just before the primary contacts (5) Fig. 7 touch, the auxiliary blade is released and will be the first part to close.

The mechanism has a direct gear drive to the main shaft of the switch and depends entirely on the operator to produce a smooth and positive motion to satisfactorily close.

#### Opening Operation

To open the switch insert the operating handle into the handle socket and rotate in a clockwise direction as far as possible (approximately 180 degrees).

The primary contacts (5 & 11) Fig. 7 will part first. When the primary blade gap is sufficient, the auxiliary blade (3) Fig. 4 will be released and will snap open at high velocity.

ADJUSTMENTS SE-100M

Upper (Closed) Mechanism Stop

Refer to Page 6.

Primary Wipe

When the switch is in the closed position, there should be no clearance between the primary blades and the primary finger support. The length of the operating rod should be adjusted so that there is noticeable force involved when the operating rod goes over center near the end of the closing stroke. When the switch is fully closed it should require between 30 and 40 pounds force to break the toggle. This force is applied at the bolt in the mechanism end of the operating rod and is applied downward perpendicular to the long axis of the operating rod. This force may be increased by lengthening the rod and decreased by shortening the rod.

Primary Gap

Refer to Page 7.

Primary Contact Alignment

Close the primary blades (12) Fig. 8 slowly by the use of the maintenance handle and note the engagement of the primary contacts (4), and guide block (10). The blades should center around the guide block without bearing heavily on either side. They should also be centered in the primary contact fingers.

If the blades press hard against the sides of the guide block, loosen the (2) bolts (11) Fig. 8 holding the block. Again check the contact alignment. If the contacts are properly aligned, reposition the guide block and bolt securely.

If the contacts are not in alignment, loosen the bolts holding the top insulator and position the insulator to center the contacts. After securing the insulators, reposition the guide blocks and tighten the bolts.

Be certain the insulator is moved only in a horizontal direction. Vertical displacement may cause misalignment of the auxiliary blade contacts.

Arc Chute Alignment

Refer to Page 7.

### Auxiliary Blade Release

The SE-100M hook release should be adjusted to release the auxiliary blade when the primary contacts and blade are 1/2" to 1" apart. Be certain the auxiliary blade latches into the arcing contacts in the chute on each operation. The auxiliary blade is released before the primary contacts are closed so that it will close first and give a positive closing action even when the switch is inadvertently operated slowly.

### Primary Contact Pressure

Refer to Page 8.

### Primary Blade Hinge Pressure

Refer to Page 9.

### Lubrication

Refer to Page 10.

### FINAL INSPECTION ALL SWITCHES

Before placing the SE-100 into service, a final inspection should be made consisting of the following:

1. Check all nuts, washers, bolts, cotter pins and terminal connections for tightness.
2. See that all bearing surfaces of the mechanism have been lubricated.
3. Operate the device slowly several times by hand and note that there is no binding or excessive friction.
4. See that any place where the surface of the paint has been damaged during installation is repainted immediately.
5. Replace all barriers, covers, and any other parts that may have been removed during installation.

### Hi-Potential Test

If the device has been stored for a long period of time before installation, it is recommended that the insulation be checked before it is placed in service. A standard 60 cycle high potential test at 14,000 volts RMS for the 4.8KV switch and 27,000 volts RMS for the 13.2 KV switch will normally indicate whether the device is satisfactory for service. With the switch contacts in the fully opened position, apply the high potential to each terminal individually for one minute with all other terminals and the frame grounded. After high potential tests

are made all organic insulating materials should be inspected for visible leakage current paths, and necessary action must be taken to replace insulation that may have been affected by moisture absorption.

The high potential test is also recommended for devices which have been removed from service and stored over an extended period of time under unfavorable atmospheric conditions.

NOTE: Before applying a hi-potential test make certain that the switch has been disconnected from both the source and load.

If the SE-100E secondary wiring is to be given a hi-potential test at 1500 volts, remove both of the motor leads from the terminal board. Failure to disconnect the motor from the circuit may cause damage to the winding insulation.

RECOMMENDED RENEWAL PARTS

DESCRIPTION	AMP RATING	QUAN. PER SWITCH	CAT. NO.		
			SE-100E	SE-100S	SE-100M
Primary Contact Finger	600	24	121A7458 P-2	121A7458 P-2	121A7458 P-2
Primary Contact Finger	1200	48	161A4219 P-2	161A4219 P-2	Not Avail.
Primary Contact Spring	600	12	456A806 P-1	456A806 P-1	456A806 P-1
Primary Contact Spring	1200	48	456A806 P-1	456A806 P-1	Not Avail.
Primary Contact Finger Retainer	600	12	105C9352 P-5	105C9352 P-5	105C9352 P-5
Primary Contact Finger Retainer	1200	24	105C9352 P-5	105C9352 P-5	Not Avail.
Primary Contact Blade	600	6	105C9365 P-3	105C9365 P-3	105C9365 P-3
Primary Contact Blade	1200	3	105C9366 P-13	105C9366 P-13	Not Avail.
Arcing Contact Finger	600	6	105C9360 P-1	105C9360 P-1	Not Req.
Arcing Contact Finger	1200	6	105C9360 G-2	105C9360 G-2	Not Req.
Arcing Contact Spring	All	6	161A5829 P-1	161A5829 P-1	Not Req.
Arcing Contact Blade	600	3	105C9366 P-4	105C9366 P-4	Not Req.
Arcing Contact Blade	1200	3	105C9366 G-1	105C9366 G-1	Not Req.
Arc Chute Assembly 4.8KV	600	3	105C9350 G-1	105C9350 G-1	105C9350 G-2
Arc Chute Assembly 4.8KV	1200	3	105C9350 G-1	105C9350 G-1	Not Avail.
Arc Chute Assembly 13.2KV	All	3	105C9350 G-2	105C9350 G-2	105C9350 G-2
Auxiliary Blade 4.8KV	All	3	114C5395 G-2	114C5395 G-2	114C5318 G-9
Auxiliary Blade 13.2KV	All	3	114C5395 G-1	114C5395 G-1	114C5318 G-9
Motor 115V-ac - 125V-dc	All	1	105C9393 P-5	Not Req.	Not Req.
Motor 230V-ac - 250V-dc	All	1	105C9393 P-6	Not Req.	Not Req.
Relay 115V-ac	All	3	137A7575 P-5	Not Req.	Not Req.
Relay 125V-dc	All	3	137A7575 P-1	Not Req.	Not Req.
Relay 230V-ac	All	3	137A7575 P-2	Not Req.	Not Req.
Relay 250V-dc	All	3	137A7575 P-3	Not Req.	Not Req.
Auxiliary Switch	All	1	137A9192 G-7	Not Req.	Not Req.
Operating Rod	600	3	114C5394 G-1	114C5394 G-1	114C5394 G-1
Operating Rod	1200	3	114C5394 G-2	114C5394 G-2	Not Avail.

GEI-88767

PART	LUBRICATION AT NORMAL MAINTENANCE PERIOD	ALTERNATE LUBRICATION REQUIRE DISASSEMBLY
Sleeve Bearings (Operating rod ends Aux. Blade Hinge, Release Hook, etc.)	Light application of SAE 20-30 oil	Clean bearings then apply D50H15 grease.
Roller & Needle Bearings	Light application of SAE 20-30 oil	Clean bearings then apply D50H15 grease.
Worm and Wheel Miter Gears	Apply D50H15 grease	Wipe clean and apply D50H15 grease.
Motor	Light application of SAE 20-30 oil at rear oil hole only	Light application of SAE 20-30 oil at rear oil hole only

Fig. 11 LUBRICATION CHART

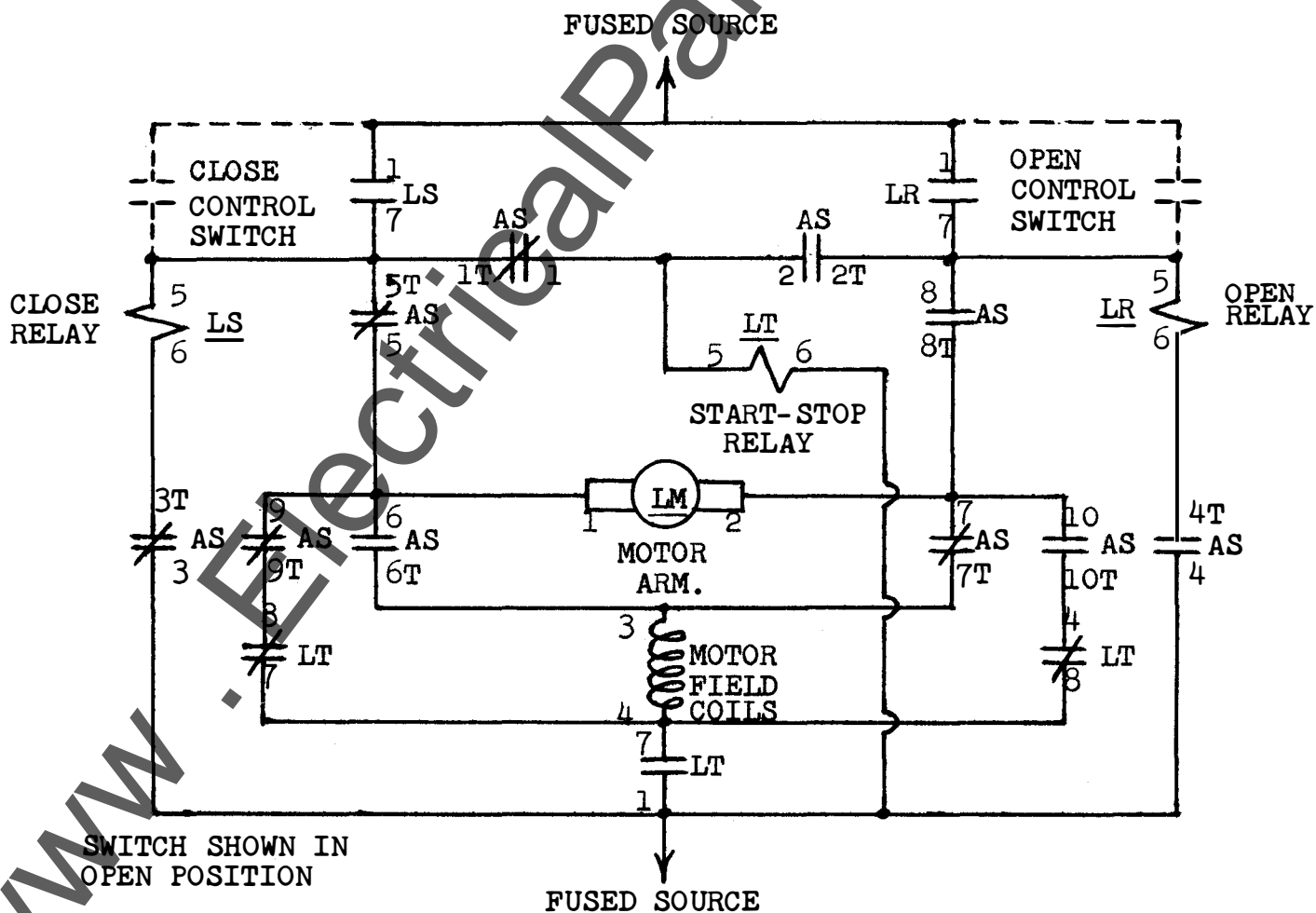

Fig. 12 SCHEMATIC WIRING DIAGRAM

1. Primary Blade Stop
2. Primary Contact Fingers
3. Primary Contact Blade
4. Primary Spring
5. Booster Spring
6. Operating Mechanism
7. Operating Hub

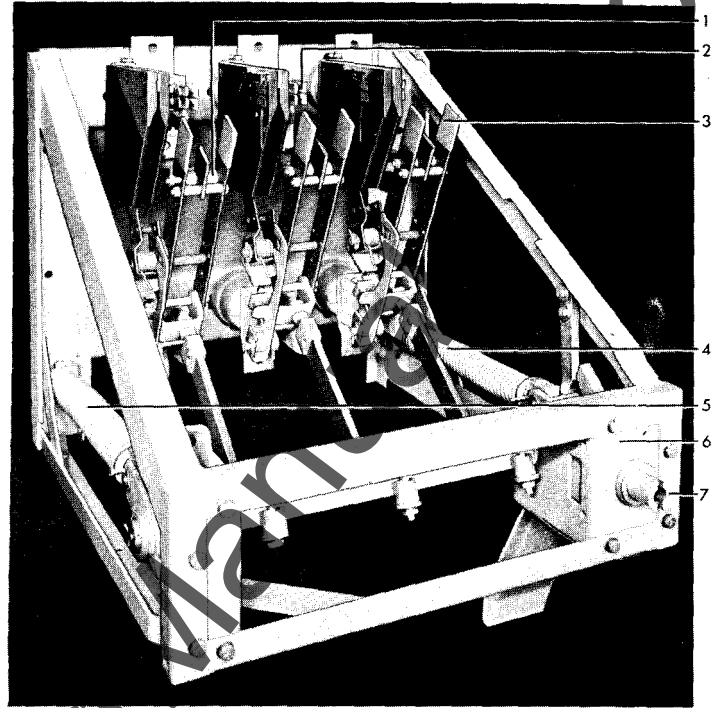

Fig. 1 SE-100S Switch Partially Open

1. Spring Stop Bolt
- 1A. Spring Stop Bolt
2. Spring Stop
3. Driving Crank
4. Hole for Spring Blocking Pin
5. Driving Lug
6. Buffer Rubber
7. Buffer Stop
8. Operating Rod
9. Operating Rod Crank
10. Operating Hub
11. Main Crank Shaft
12. Maintenance Handle

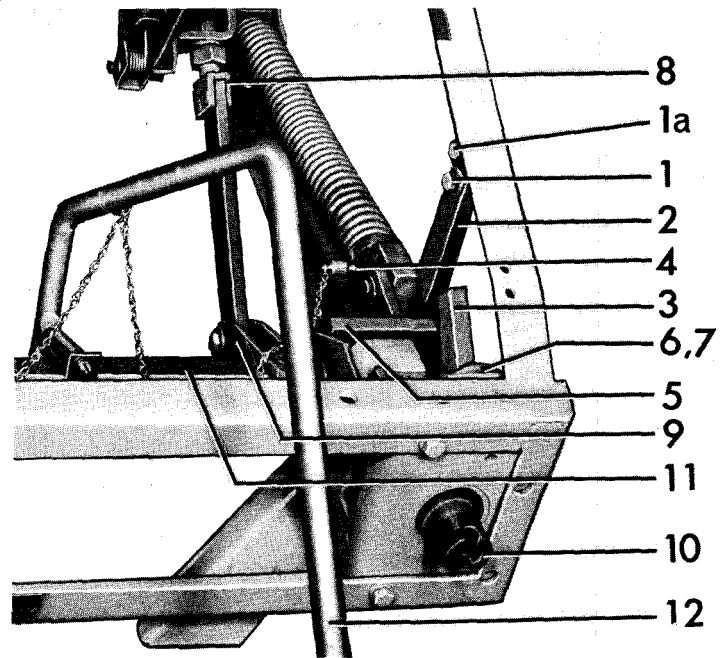
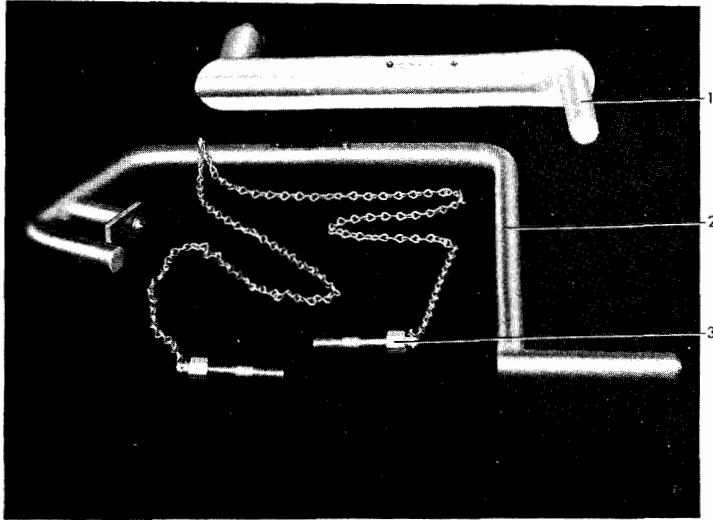
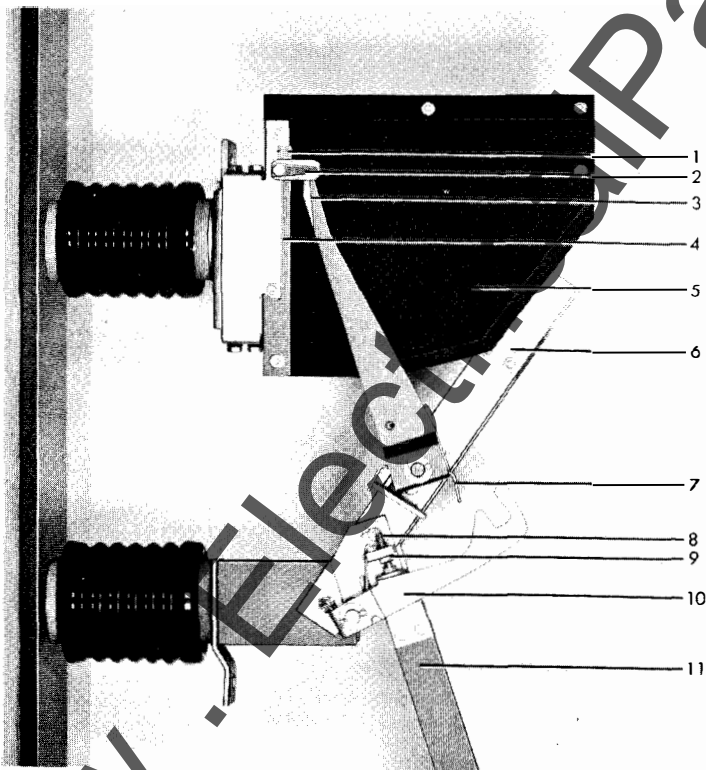

Fig. 2 Spring Drive Mechanism



1. Operating Handle
2. Maintenance Handle
3. Spring Blocking Pin

Fig. 3 Operating and Maintenance Handles



1. Blade Stop Block
2. Arc Chute Contacts
3. Auxiliary Blade
4. Spacer
5. Arc Chute Side
6. Primary Contact Blade
7. Auxiliary Blade Spring
8. Camming Screw
9. Lock Nut
10. Auxiliary Blade Release Hook
11. Operating Rod

Fig. 4 Unit Pole Opening

1. Collar
2. Buffer Rubber
3. Upper Buffer Stop
4. Booster Crank
5. Buffer Rubber
6. Lower Buffer Stop

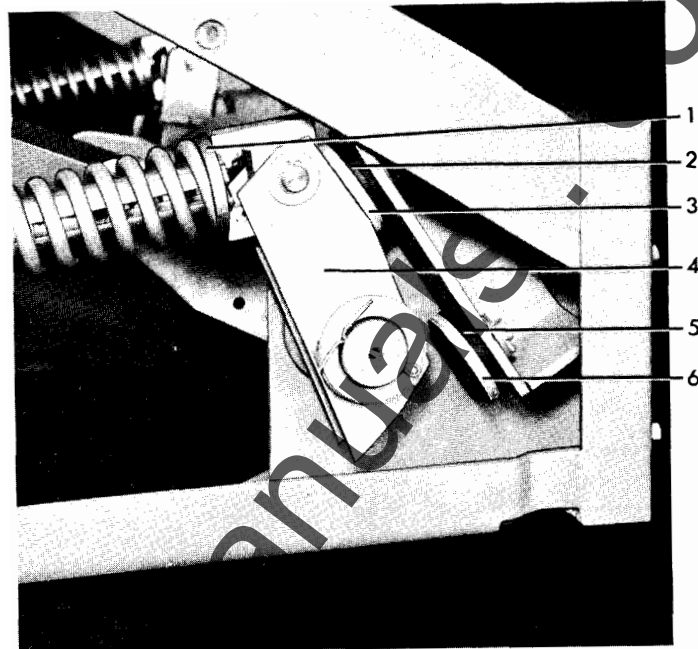

Fig. 5 Buffer Assembly

1. Auxiliary Blade Spring
2. Auxiliary Blade
3. Release Hook
4. Spring Stop
5. Camming Screw
6. Lock Nut
7. Adjusting Nut
8. Release Hook Spring
9. Operating Rod
10. Operating Rod Crank
11. Main Crank Shaft

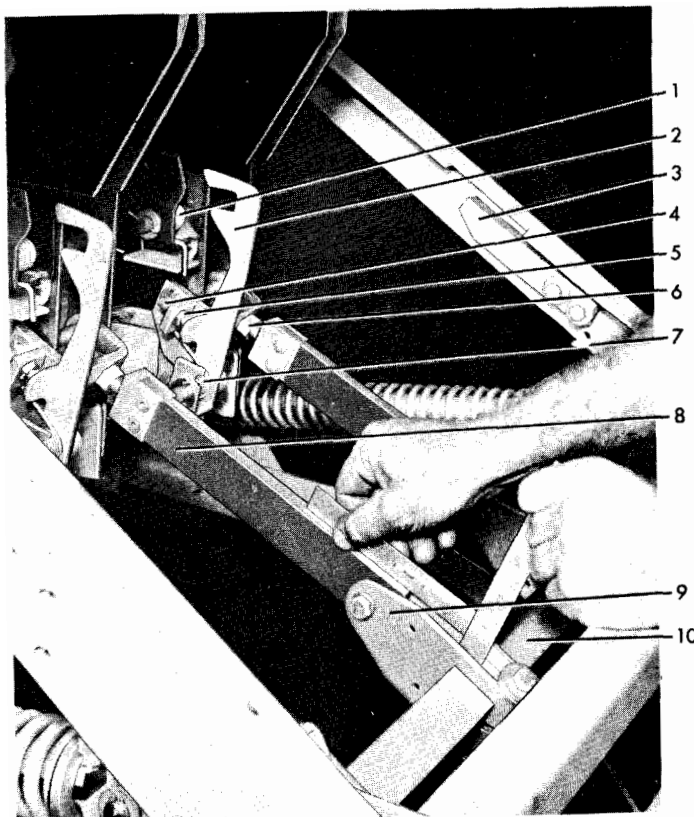

Fig. 6 Switch Blade Adjustments

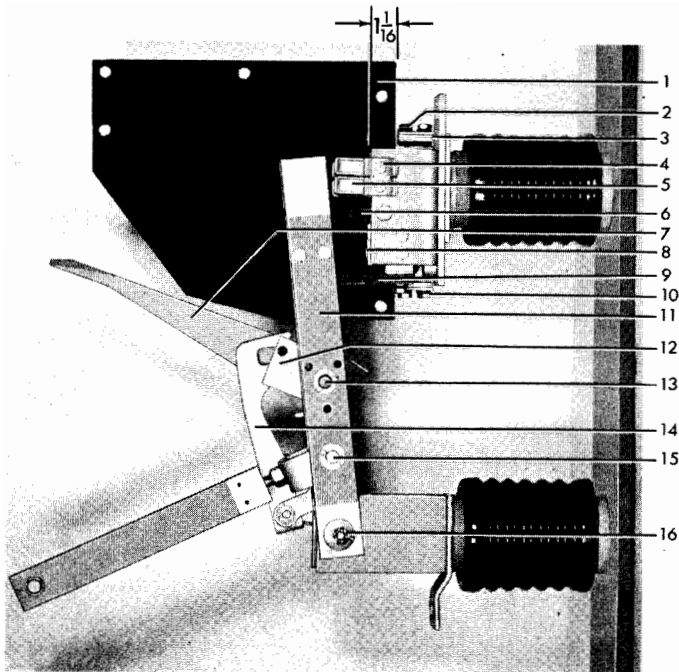

Fig. 7 Unit Pole Closing

1. Buffer Stop
2. Arc Chute Mounting Bolts
3. Shims
4. Contact Bolt
5. Primary Contact Fingers
6. Arcing Contact Fingers
7. Auxiliary Blade
8. Buffer Stop
9. Guide Block
10. Arc Chute Mounting Bolts
11. Primary Contact Blade
12. Auxiliary Contact Blade
13. Rivot Pin for Auxiliary Blade
14. Auxiliary Blade Release Hook
15. Operating Rod Clevis Pin
16. Hinge Pin

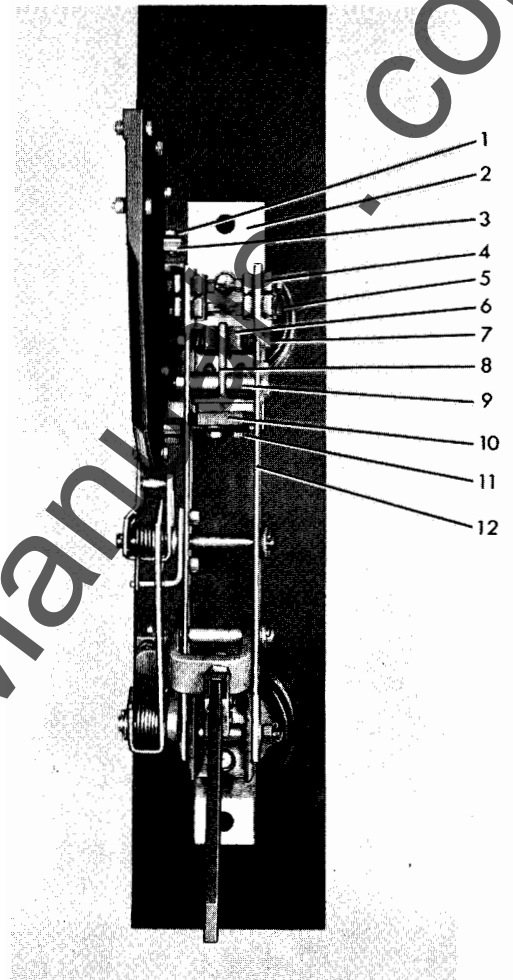

Fig. 8 Contact Arrangement

1. Arc Chute Mounting Bolts
2. Upper Terminal
3. Shims
4. Primary Contacts
5. Contact Bolts
6. Arcing Contact Fingers
7. Contact Bolt
8. Movable Arcing Contact
9. Tube Spacer
10. Guide Block
11. Buffer Block Bolts
12. Primary Contact Blades

1. Arc Chute
2. Stationary Primary Contact
3. Primary Blade Stop
4. Primary Blade

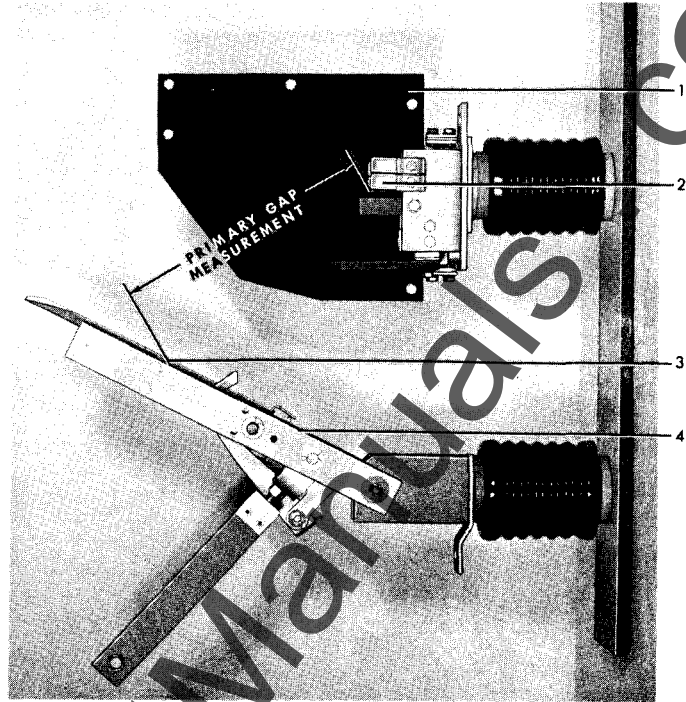
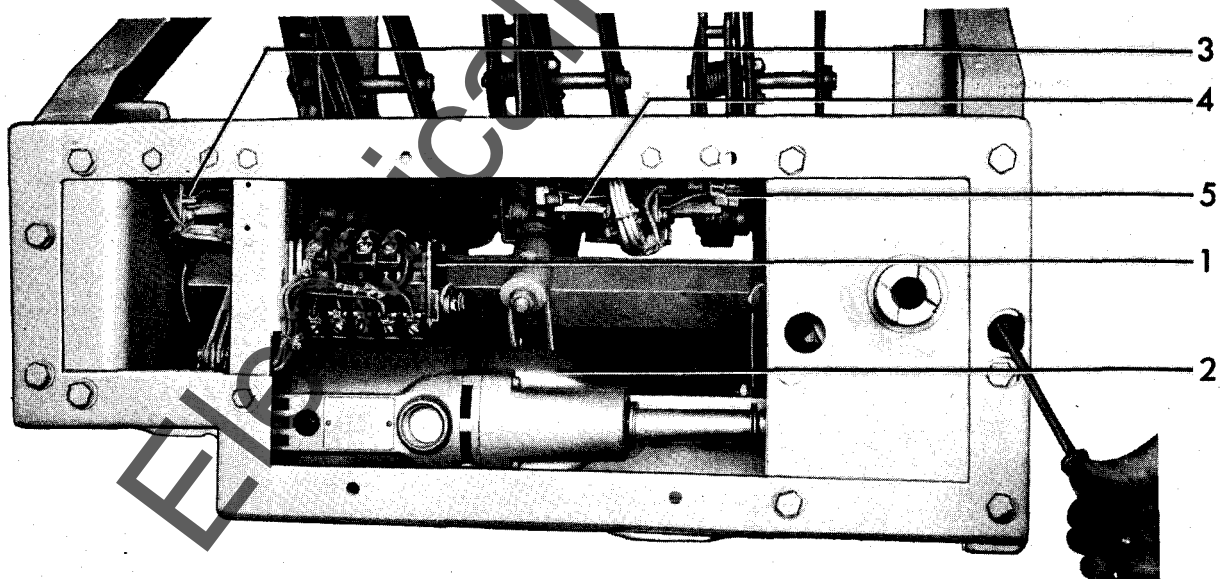

Fig. 9 Unit Pole Fully Open



1. Auxiliary Switch
2. Motor
3. Start-Stop Relay
4. Close Relay
5. Open Relay

Fig. 10 Electrical Operator

**GENERAL ELECTRIC INSTALLATION AND SERVICE ENGINEERING OFFICES**

**FIELD SERVICE OFFICE CODE KEY**

- \* Mechanical & Nuclear Service
- † Electrical & Electronic Service
- ‡ Marine Service
- × Transportation

FOR YOUR LASTING SATISFACTION... with the performance and availability of your General Electric equipment, GE provides this nationwide network of field service offices, serving utility, industrial, transportation and marine users. Qualified field engineers provide installation, start-up, employee training, engineering maintenance and other services, throughout the productive life of the equipment. For full information, call your nearest Installation & Service Engineering Office.

**ALABAMA**  
 \* † Birmingham 35205 . . . . . 2151 Highland Ave.  
 \* † ‡ Mobile 36609 . . . . . 1111 S. Beltline Highway

**ALASKA**  
 † Anchorage 99501 . . . . . 115 Whitney Rd.

**ARIZONA**  
 \* † Phoenix 85012 . . . . . 3550 N. Central Ave.  
 † Tucson 85718 . . . . . 151 S. Tucson Blvd.

**ARKANSAS**  
 † North Little Rock 72119 . . . . . 120 Main St.

**CALIFORNIA**  
 \* † ‡ Los Angeles 90054 . . . . . 212 N. Vignes St.  
 † Palo Alto 94303 . . . . . 980 San Antonio Rd.  
 † Sacramento 95808 . . . . . 2407 J St.  
 † San Diego 92103 . . . . . 2580 First Ave.  
 \* † ‡ San Francisco 94119 . . . . . 55 Hawthorne St.  
 † Vernon 90058 . . . . . 3035 E. 46th St.

**COLORADO**  
 \* † Denver 80206 . . . . . 201 University Blvd.

**CONNECTICUT**  
 \* † Meriden 06450 . . . . . 1 Prestige Dr.

**FLORIDA**  
 † ‡ Jacksonville 32203 . . . . . 4040 Woodcock Dr.  
 † ‡ Miami 33134 . . . . . 4100 W. Flagler St.  
 \* † ‡ Tampa 33609 . . . . . 2106 S. Lois Ave.

**GEORGIA**  
 \* † ‡ Atlanta 30309 . . . . . 1860 Peachtree Rd., NW  
 † ‡ Savannah 31405 . . . . . 5002 Paulsen St.

**HAWAII**  
 \* † ‡ Honolulu 96813 . . . . . 440 Coral St.

**ILLINOIS**  
 \* † ‡ × Chicago 60680 . . . . . 840 S. Canal St.

**INDIANA**  
 † ‡ Evansville 47705 . . . . . 2709 Washington Ave.  
 † Fort Wayne 46807 . . . . . 3606 S. Calhoun St.  
 \* † Indianapolis 46207 . . . . . 3750 N. Meridian St.

**IOWA**  
 † Davenport 52805 . . . . . P. O. Box 630, 1039 State St., Bettendorf

**KENTUCKY**  
 † Louisville 40218 . . . . . 2300 Meadow Dr.

**LOUISIANA**  
 † Baton Rouge 70806 . . . . . 8312 Florida Blvd.  
 \* † ‡ New Orleans 70125 . . . . . 4747 Earhart Blvd.  
 \* † ‡ Shreveport 71104 . . . . . 2620 Centenary Blvd.  
 † Monroe 71201 . . . . . 1028 North 6th St.

**MARYLAND**  
 \* † ‡ Baltimore 21201 . . . . . 1 N. Charles St.

**MASSACHUSETTS**  
 \* † ‡ Wellesley 02181 . . . . . 1 Washington St.

**MICHIGAN**  
 \* † ‡ Detroit 48202 . . . . . 700 Antoinette St.  
 † Jackson 49201 . . . . . 210 W. Franklin St.  
 † Saginaw 48607 . . . . . 1008 Second National Bank Bldg.

**MINNESOTA**  
 \* † ‡ Duluth 55802 . . . . . 300 W. Superior St.  
 \* † ‡ Minneapolis 55416 . . . . . 1500 Lilac Drive So.

**MISSOURI**  
 \* † ‡ Kansas City 64199 . . . . . 911 Main St.  
 † ‡ St. Louis 63101 . . . . . 1015 Locust St.

**MONTANA**  
 † Butte 59701 . . . . . 103 N. Wyoming St.

**NEBRASKA**  
 \* † Omaha 68102 . . . . . 409 S. 17th St.

**NEW JERSEY**  
 \* † Millburn 07041 . . . . . 25 E. Willow St.

**NEW YORK**  
 † ‡ Albany 12205 . . . . . 15 Computer Drive, West  
 † ‡ Buffalo 14205 . . . . . 625 Delaware Ave.  
 \* † ‡ × New York 10022 . . . . . 641 Lexington Ave.  
 \* † Rochester 14604 . . . . . 89 East Ave.  
 \* † Syracuse 13206 . . . . . 3532 James St.

**NORTH CAROLINA**  
 \* † ‡ Charlotte 28207 . . . . . 141 Providence Rd.  
 † ‡ Wilmington . . . . . Reigelwood 28456 . . . . . P. O. Box 186

**OHIO**  
 † ‡ Cincinnati 45206 . . . . . 2621 Victory Pkwy.  
 \* † ‡ Cleveland 44104 . . . . . 1000 Lakeside Ave.  
 † Columbus 43229 . . . . . 1110 Morse Rd.  
 † Toledo 43605 . . . . . 3425 Douglas Rd.  
 † Youngstown 44507 . . . . . 272 Indiana Ave.

**OKLAHOMA**  
 \* † Oklahoma City 73106 . . . . . 2000 Classen Blvd.  
 † Tulsa 74105 . . . . . P. O. Box 7646, Southside Sta.

**OREGON**  
 † Eugene 97401 . . . . . 1170 Pearl St.  
 \* † ‡ Portland 97210 . . . . . 2929 NW 29th Ave.

**PENNSYLVANIA**  
 † Allentown 18102 . . . . . 1444 Hamilton St.  
 \* † ‡ Philadelphia 19102 . . . . . 3 Penn Center Plaza  
 \* † Pittsburgh 15222 . . . . . 300 6th Avenue Bldg.

**SOUTH CAROLINA**  
 † ‡ Columbia 29204 . . . . . 2700 Middleburg Dr.  
 † Greenville 29505 . . . . . 41 No. Pleasantburg Dr.

**TENNESSEE**  
 \* † Chattanooga 37411 . . . . . 5800 Bldg. Eastgate Center  
 † Memphis 38130 . . . . . 3385 Airways Blvd.

**TEXAS**  
 \* † ‡ Amarillo 79101 . . . . . 303 Polk St.  
 † ‡ Beaumont 77704 . . . . . 1385 Calder Ave.  
 † ‡ Corpus Christi 78401 . . . . . 205 N. Chaparral St.  
 † ‡ Dallas 75222 . . . . . 8101 Stemmons Freeway  
 † ‡ El Paso 79945 . . . . . 215 N. Stanton  
 † ‡ Fort Worth 76102 . . . . . 408 W. Seventh St.  
 † ‡ Houston 77027 . . . . . 4219 Richmond Ave.  
 † ‡ San Antonio 78204 . . . . . 434 S. Main St.

**UTAH**  
 † Salt Lake City 84111 . . . . . 431 S. Third East St.

**VIRGINIA**  
 † Newport News 23601 . . . . . 311 Main St.  
 † ‡ Richmond 23230 . . . . . 1508 Willow Lawn Dr.  
 † ‡ Roanoke 24015 . . . . . 2018 Colonial Ave.

**WASHINGTON**  
 \* † ‡ Seattle 98188 . . . . . 112 Andover Park East, Tukwila  
 † Spokane 99202 . . . . . E. 1805 Trent Ave.

**WEST VIRGINIA**  
 \* † Charleston 25328 . . . . . 306 MacCorkle Ave., SE

**WISCONSIN**  
 † Appleton 54911 . . . . . 3003 West College Dr.  
 † ‡ Milwaukee 53202 . . . . . 615 E. Michigan St.

**GENERAL ELECTRIC SERVICE SHOPS**

WHEN YOU NEED SERVICE... These GE Service Shops will repair, recondition, and rebuild your electric apparatus. The facilities are available day and night, seven days a week, for work in the shops or on your premises. Latest factory methods and genuine GE renewal parts are used to maintain performance of your equipment. For full information about these services, contact your nearest service shop or sales office.

**ALABAMA**  
 • • Birmingham 35211 . . . . . 1500 Mims Ave., S. W.  
 • • Mobile 36609 . . . . . 721 Lakeside Dr.

**ARIZONA**  
 • (Phoenix) Glendale 85019 . . . . . 4911 W. Colter St.  
 • Phoenix 85019 . . . . . 3940 W. Clarendon St.  
 • Tucson 85713 . . . . . 2942 So. Palo Verde Ave.

**CALIFORNIA**  
 • Los Angeles 90301 . . . . . 6900 Stanford Ave.  
 • (Los Angeles) Anaheim 92805 . . . . . 3801 E. LaPalma Ave.  
 • (Los Angeles) Inglewood 90301 . . . . . 228 W. Florence Ave.  
 • Sacramento 95814 . . . . . 99 North 17th St.  
 • (San Francisco) Oakland 94608 . . . . . 1850 34th St.

**COLORADO**  
 • • Denver 80205 . . . . . 3353 Larimer St.

**CONNECTICUT**  
 • • (Southington) Plantsville 06479 . . . . . 370 Water St.

**FLORIDA**  
 • Jacksonville 32203 . . . . . 2020 W. Beaver St.  
 • (Miami) Hialeah 33010 . . . . . 1962 East 28th St.  
 • Tampa 33601 . . . . . 19th & Grant Sts.

**GEORGIA**  
 • (Atlanta) Chamblee 30341 . . . . . 5035 Peachtree Industrial Blvd.  
 • Atlanta . . . . . 2379 John Glenn Dr.

**ILLINOIS**  
 • • Chicago 60638 . . . . . 6045 S. Nottingham Ave.

**INDIANA**  
 • Evansville 47711 . . . . . 401 N. Congress Ave.  
 • Ft. Wayne 46803 . . . . . 1731 Edsall Ave.  
 • Hammond 46320 . . . . . 1138 164th Place  
 • Indianapolis 46222 . . . . . 1740 W. Vermont St.

**IOWA**  
 • (Davenport) Bettendorf 52722 . . . . . 1025 State St.

**KENTUCKY**  
 • Louisville 40209 . . . . . 3900 Crittenden Drive

**LOUISIANA**  
 • Baton Rouge 70814 . . . . . 10955 North Dual St.  
 • New Orleans 70114 . . . . . 1115 DeArmas St.

**MARYLAND**  
 • • Baltimore 21230 . . . . . 920 E. Fort Ave.

**MASSACHUSETTS**  
 • • (Boston) Medford 02155 . . . . . 3960 Mystic Valley Pkwy.

**MICHIGAN**  
 • • Δ (Detroit) Riverview . . . . . 18075 Krause Ave.  
 • • Flint 48505 . . . . . 1506 E. Carpenter Rd.

**MINNESOTA**  
 • Duluth 55807 . . . . . 50th Ave. W & St. Louis Bay  
 • Minneapolis 55430 . . . . . 2025 49th Ave., N.

**MISSOURI**  
 • • Kansas City 64120 . . . . . 3525 Gardner Ave.  
 • • St. Louis 63110 . . . . . 1115 East Rd.

**NEW JERSEY**  
 • • New Brunswick 08902 . . . . . 3 Lawrence St.

**NEW MEXICO**  
 • Albuquerque 87109 . . . . . 4420 McLeod Rd. NE

**NEW YORK**  
 • Albany 12205 . . . . . 1097 Central Ave.  
 • (Buffalo) Tonawanda 14150 . . . . . 175 Milens Rd.  
 • (Long Island) Old Bethpage 11804 . . . . . 183 Bethpage-Sweet Hollow Rd.  
 • (New York City) North Bergen, N. J. 07012 . . . . . 6001 Tonnelle Ave.  
 • (New York City) Clifton, N. J. 07012 . . . . . 9 Brighton Rd.  
 • Δ Schenectady 12305 . . . . . 1 River Rd.  
 • Syracuse 13208 . . . . . 1015 E. Hiawatha Blvd.

**NORTH CAROLINA**  
 • • Charlotte 28208 . . . . . 2328 Thrift Rd.

**OHIO**  
 • Akron (Canton) 44720 . . . . . 7900 Whipple Ave. N. W.  
 • Cincinnati 45202 . . . . . 444 West 3rd St.  
 • Δ Cleveland 44125 . . . . . 4477 East 49th St.  
 • Columbus 43229 . . . . . 6660 Huntley Rd.  
 • Toledo 43605 . . . . . 405 Dearborn Ave.  
 • Youngstown 44507 . . . . . 272 E. Indiana Ave.

**OKLAHOMA**  
 • Tulsa 74145 . . . . . 5220 S. 100th East Ave.

**OREGON**  
 • Eugene 97402 . . . . . 570 Wilson St.  
 • • Portland 97210 . . . . . 2727 NW 29th Ave.

**PENNSYLVANIA**  
 • Allentown 18103 . . . . . 668 E. Highland St.  
 • (Delaware Valley) Cherry Hill, N. J. . . . . 08034  
 • Johnstown 15802 . . . . . 841 Oak St.  
 • Philadelphia 19124 . . . . . 1040 East Erie Ave.  
 • (Pittsburgh) West Mifflin 15122 . . . . . 4930 Buttermilk Hollow Rd.  
 • York 17403 . . . . . 54 N. Harrison St.

**SOUTH CAROLINA**  
 • (Charleston) No. Charleston 29401 . . . . . 2490 Debonair St.

**TENNESSEE**  
 • Knoxville 37914 . . . . . 2621 Governor John Sevier Hwy.  
 • Memphis 38107 . . . . . 708 North Main St.

**TEXAS**  
 • Beaumont 77705 . . . . . 1490 W. Cardinal Dr.  
 • Corpus Christi 78401 . . . . . 115 Waco St.  
 • Dallas 75235 . . . . . 3202 Manor Way  
 • Houston 77036 . . . . . 5534 Harvey Wilson Dr.  
 • Houston 77036 . . . . . 6916 Harwin Dr.  
 • Midland 79701 . . . . . 704 S. Johnston St.

**UTAH**  
 • Salt Lake City 84110 . . . . . 301 S. 7th West St.

**VIRGINIA**  
 • Richmond 23224 . . . . . 1403 Ingram Ave.  
 • Roanoke 24013 . . . . . 1004 River Ave., SE

**WASHINGTON**  
 • Seattle 98134 . . . . . 3422 First Ave., South  
 • Spokane 99211 . . . . . E. 4323 Mission St.

**WEST VIRGINIA**  
 • • Charleston 25328 . . . . . 306 MacCorkle Ave., SE

**WISCONSIN**  
 • (Appleton) Menasha 54951 . . . . . 1000 State St.  
 • Milwaukee 53207 . . . . . 615 E. Michigan St.

• Electrical/Mechanical Service Shop • Instrumentation Shop Δ Special Manufacturing Shop