



# Power/Vac<sup>®</sup>

*Metalclad Switchgear  
4.16kV-250 MVA through  
13.8k-1000 MVA*



**Underwriters  
Laboratories Inc.<sup>®</sup>**

DE-261 BL

Third Party Verification Has Been Achieved Thru  
UL<sup>®</sup> Listing of GE POWER/VAC Switchgear

# POWER/VAC® METALCLAD SWITCHGEAR TRANSFORMED THE INDUSTRY WITH VACUUM TECHNOLOGY AND IS STILL THE LEADER IN EXPERIENCE

In 1977 General Electric introduced POWER/VAC® and transformed the metalclad switchgear industry. Clean, quiet, reliable and durable, POWER/VAC metalclad switchgear offered significant advantages over air magnetic designs. Now many companies offer vacuum switchgear, many of them look-alikes to POWER/VAC, but not one can match POWER/VAC's years of in-service experience.

## More Than 500,000 Interrupter Years of Experience

GE pioneered experimental vacuum interruption in the 1920's, refined it with improved materials and new manufacturing techniques in the 30's and 40's, and introduced the world's first vacuum interrupter distribution breaker in the 1960's. To date, this interrupter design has accumulated over 500,000 interrupter years of reliable field service. It's the heart of thousands of POWER/VAC breakers in service with ratings from 4.16kV - 250 MVA through 13.8kV - 1000 MVA at 1200, 2000 and 3000 amps.

## World-wide Acceptance

POWER/VAC metalclad switchgear is in service throughout the U.S. and in dozens of other countries. Many installations are subjected to harsh operating environments: salt air aboard offshore platforms miles out to sea, high altitudes in the mountains of Chile, excessive heat at fertilizer plants in Trinidad, humidity at petro-processing operations in Venezuela, wind and sand at power plants, public works and oil exploration installations in Saudi Arabia. It is online in paper mills, steel mills, cement mills, petro-chemical facilities and in electric utility systems the world over — wherever a high value is placed on reliability, POWER/VAC is the accepted leader.

© 1985 GENERAL ELECTRIC COMPANY

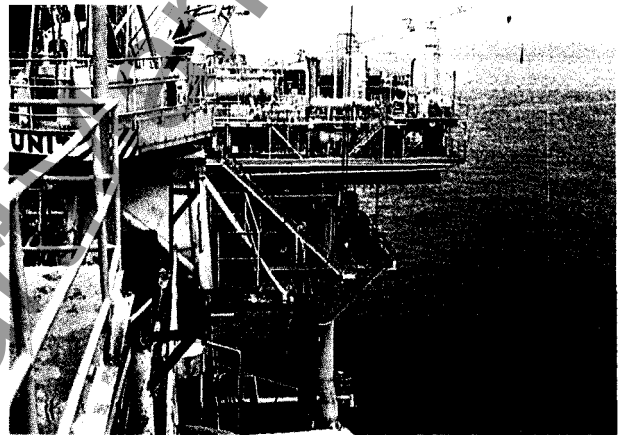

POWER/VAC switchgear withstands rough seas and salt air aboard this natural gas platform.

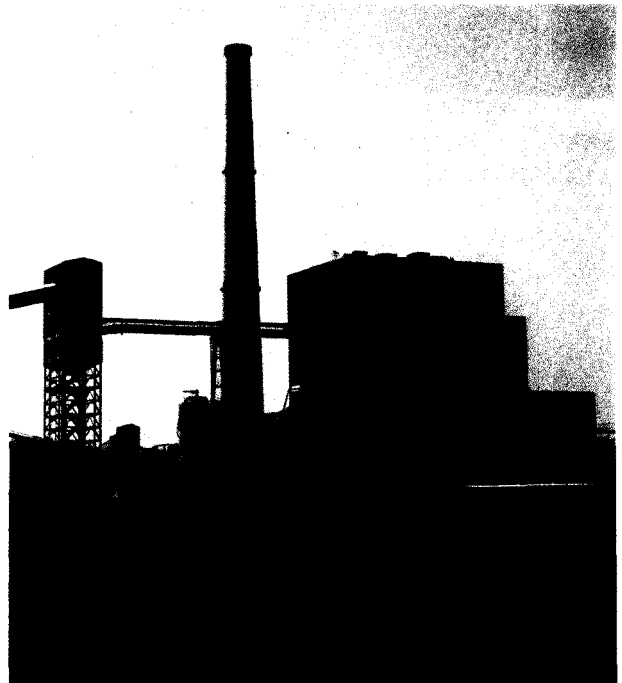

POWER/VAC switchgear helps protect electric utility systems around the world.

---

# THE POWER/VAC® TRADITION OF QUALITY

---



POWER/VAC switchgear is on the job day after day in the severe operating environment found in this steel mill...

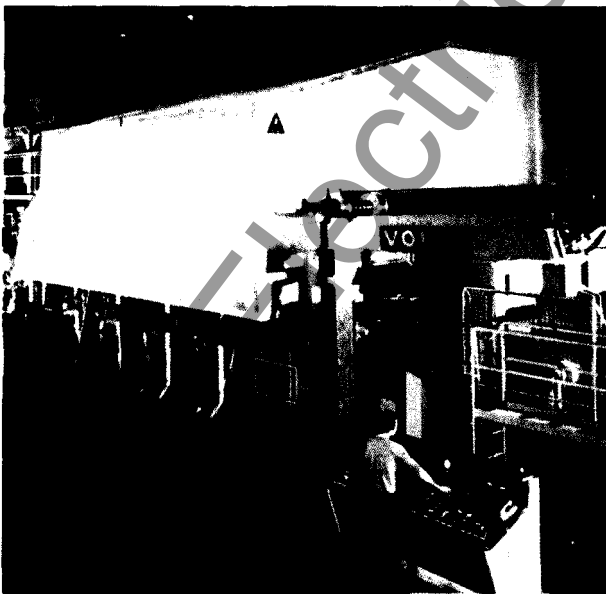

and in this paper mill.

## POWER/VAC Integrity

POWER/VAC switchgear is designed, assembled and tested to meet or exceed applicable ANSI, IEEE, and NEMA standards. It incorporates the compartment concept with grounded metal barriers that segregate primary functions so that no live parts are exposed. Safety interlocks are standard, as are closed door racking and storage, breaker position indicator, and positively actuated safety shutters. Combining the time-honored advantages of General Electric metalclad switchgear — flexibility, quality and economy — with vacuum interruption's longer life, design simplicity, smaller size and weight, and reduced maintenance, POWER/VAC has built its own tradition of superiority.

## POWER/VAC Flexibility

POWER/VAC switchgear is designed to meet a wide variety of protection and switching applications. All functional units such as incoming line, radial feeders, feeder bypass, bus-tie, bus-entrance and auxiliary units are available to give your system-planning staff a wide range of latitude. These basic functions, plus the versatility of one-high or two-high stacking, afford maximum value for your application dollar.

## POWER/VAC Quality

Manufactured, assembled and tested all in the same sophisticated facility, POWER/VAC is the product of state-of-the-art manufacturing processes. Precision-tooled parts, computer-aided design and advanced production techniques, as well as the protection of the "E Coat" paint process have resulted in a standard of excellence unmatched in the industry.

# POWER/VAC® PUTS OVER 500,000 VACUUM INTERRUPTER YEARS OF EXPERIENCE TO WORK FOR YOU

The heart of every POWER/VAC switchgear is the vacuum interrupter. The POWER/VAC interrupter is a reliable device that provides fast, quiet power switching. It consists of a pair of butt contacts, a vapor-condensing shield and a bellows through which one of the contacts moves, all sealed in a vacuum-tight enclosure.

Vacuum is recognized as having many advantages over other arc interruption technologies. It is a nearly perfect dielectric for arc extinction. Also because the vacuum interrupter is smaller, the circuit breakers can be reduced in size, weight and complexity. No oil, gas or high pressure air is needed to aid interruption, so breaker design can be further simplified.

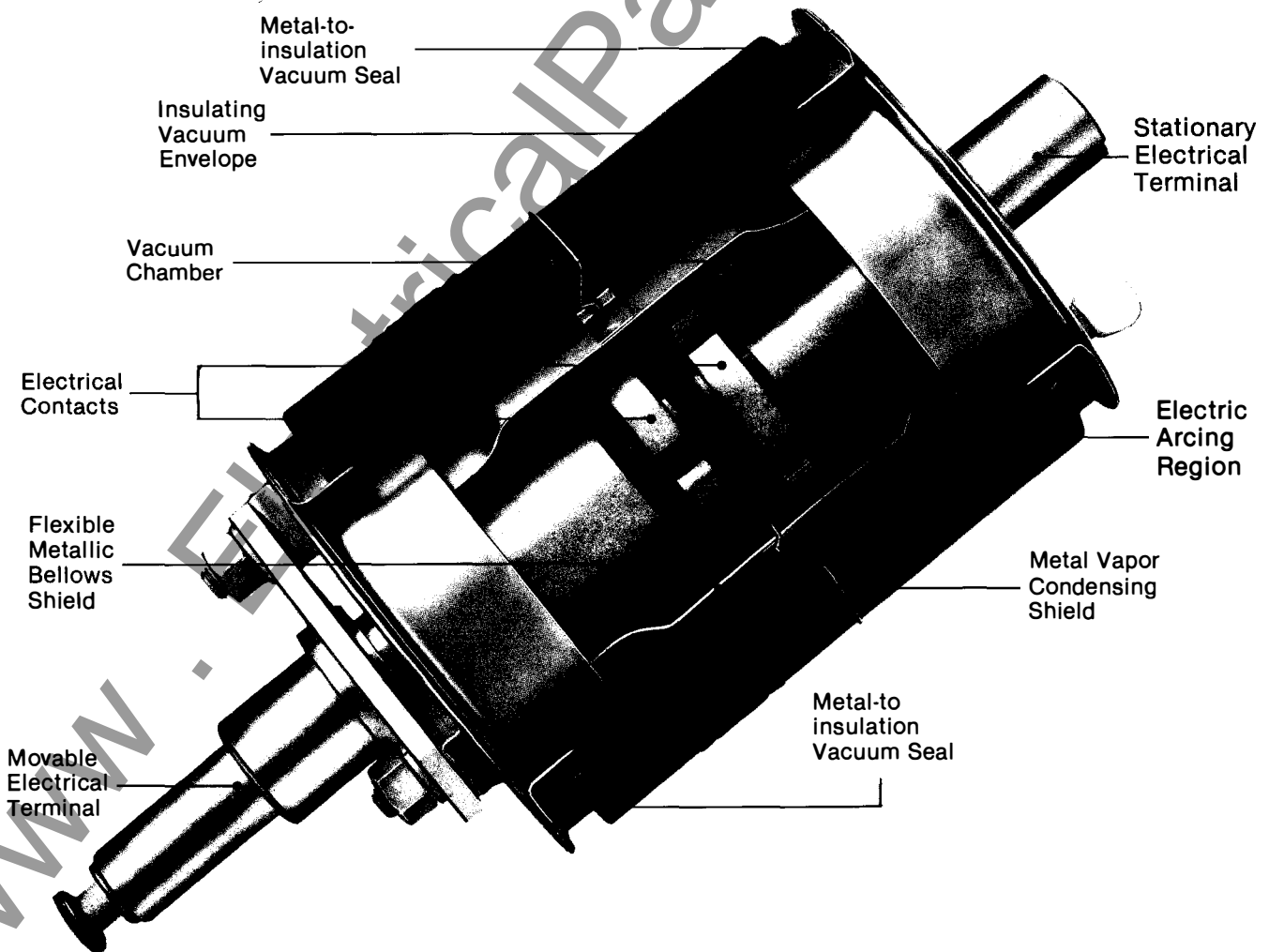

# POWER/VAC® VACUUM INTERRUPTERS OFFER ADVANTAGES OVER OTHER TECHNOLOGIES

## POWER/VAC is Easier to Maintain

When maintenance is required, POWER/VAC reduces the time to perform it by up to 50% compared to other technologies. For example, contacts require no maintenance over the life of the vacuum interrupter because they are sealed in a high-vacuum environment free from contamination. Vacuum interruption also eliminates the time-consuming task of removing heavy arc chutes and box barriers inherent in air magnetic gear, as well as the subsequent cleaning, inspecting contacts, replacing parts and retesting. Vacuum likewise eliminates the special equipment needed to purify the interrupting medium in SF<sub>6</sub> and oil designs.

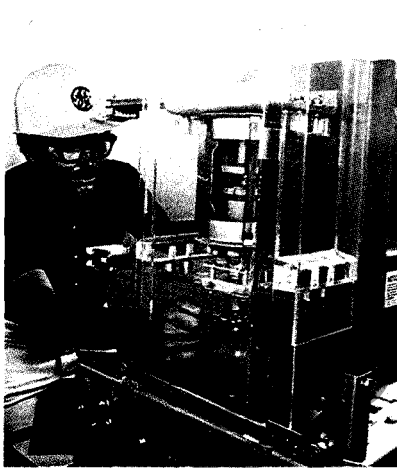

The heart of General Electric POWER/VAC switchgear is this vacuum interrupter — a high-technology device that provides quiet 5-cycle power switching and long service life. It also reduces equipment size and weight, lowers maintenance requirements and improves operating reliability. The mounting arrangement of a cutaway interrupter is shown in the above photo behind a clear plastic sheet.

## Reliable, Quiet Arc Interruption

Arc interruption typically takes place at the first current zero after contact separation because the high dielectric strength of the vacuum gap results in an extremely short clearing time. Arc extinction is silent and the sound level of the mechanism is low.

## Little Contact Erosion Means Long Service Life

There is little contact erosion because the contact geometry causes the arc to move from the contact region to the spirals of the electrical contacts. This means that you can expect extended service life from POWER/VAC vacuum interrupters.

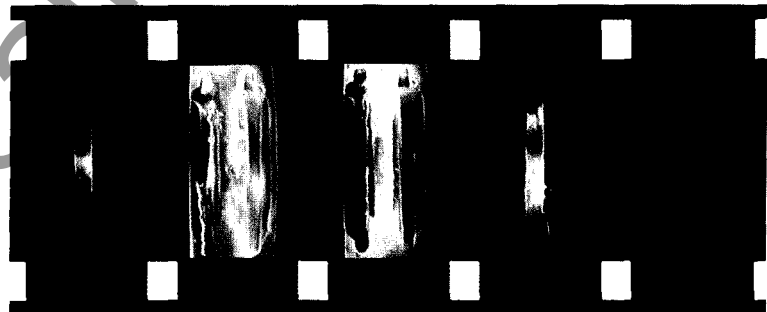

1. Contacts are open, with current at low value (see curve below), the arc is diffused.
2. At peak of the current wave, an intense arc encompasses entire contact region.
3. As current decreases, intensity and energy of arc lessens.
4. Nearing current zero, only a faint glow of arc remains.
5. After current zero with recovery voltage applied, arc is fully extinguished.

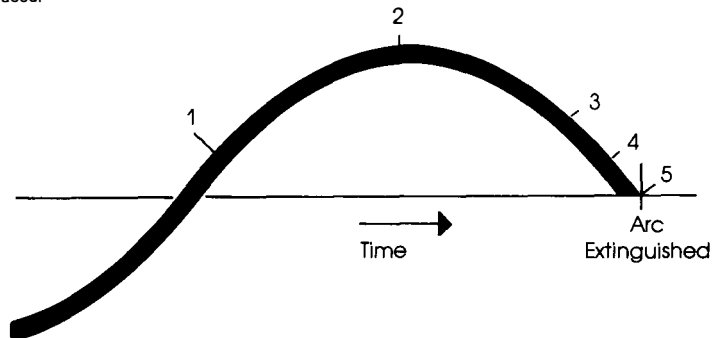

---

# POWER/VAC® VACUUM BREAKERS DESIGNED FOR QUALITY AND SAFETY

---

## Standardization Means High Quality

A high degree of standardization has been achieved with POWER/VAC breakers. All breakers are the same size, regardless of voltage or interrupting capability. Additionally, most parts of the frame, primary conductors, disconnects and mechanism are interchangeable throughout the breaker product line. This results in a higher quality product and reduces training time for operating and maintenance personnel.

## Interlock System Protects Operating Personnel

For personnel safety, POWER/VAC breakers are designed with a number of mechanical and electrical interlocks. For example, breaker contacts must be open before the breaker can be moved to or from the CONNECT position. A positive mechanical stop is provided when the breaker reaches the CONNECT or TEST/DISCONNECT positions. Mechanical interference interlocks are provided to permit only the insertion of properly rated breakers into any specific compartment. These and other necessary interlocks provide a comprehensive protection system. Furthermore, springs automatically discharge when the breaker is withdrawn from the CONNECT position and breakers cannot be inserted in the closed position. Closed door drawout design also contributes an extra measure of operator protection.

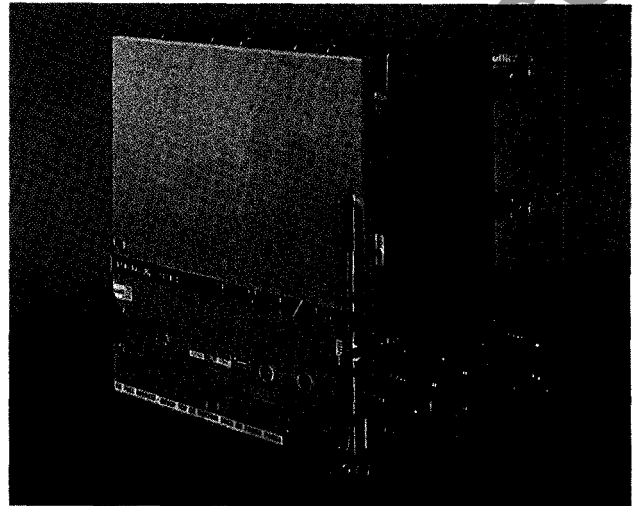

1. Front Panel

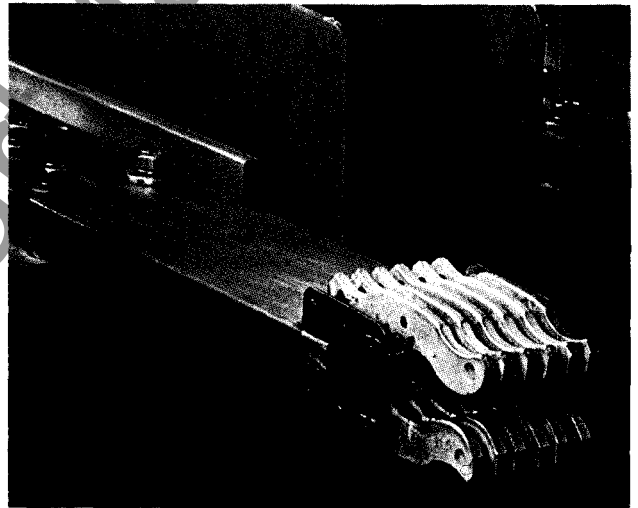

2. Primary Disconnect

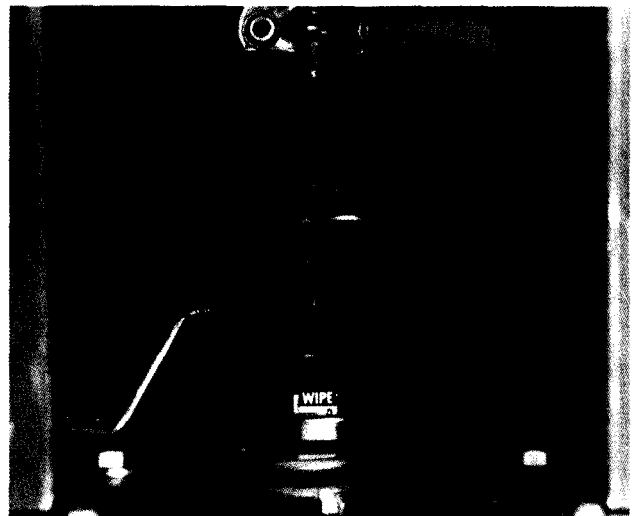

3. Contact Erosion Indicator

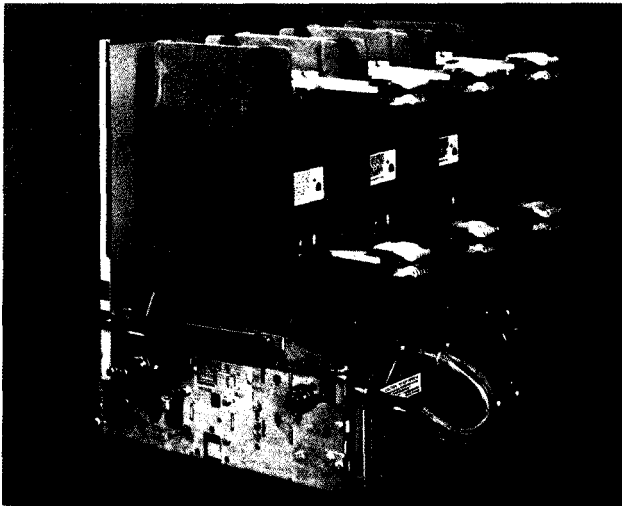

4. Interrupter Support

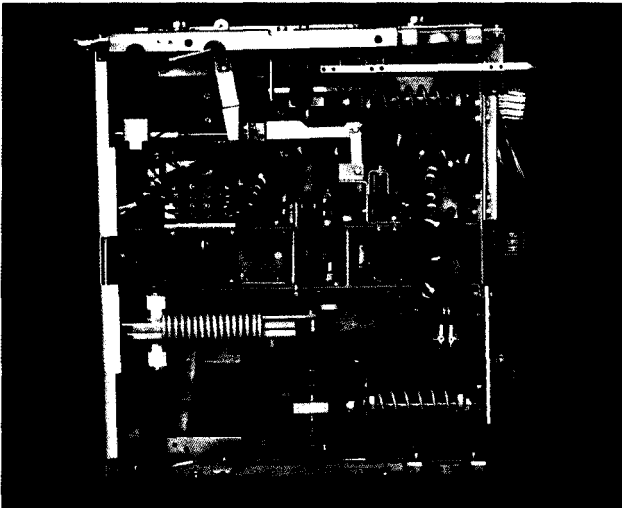

5. Breaker Mechanism



6. Roll-in Option

## Breaker Features

**1. FRONT PANEL:** This 11-gauge steel front panel fits into a collar-frame in the equipment when the breaker is in the CONNECT position. It provides a metal barrier between the breaker compartment and the secondary device compartment. Well marked and easy-to-read operating controls and indicators include TRIP button, CLOSE button, OPEN/CLOSE indicator, CHARGE/DISCHARGE indicator, OPERATIONS counter and provision for manual charging of the breaker.

**2. PRIMARY DISCONNECT:** The primary disconnect finger set is rugged and easy to inspect. Designed for optimum contact, built of silver-plated copper and tested for continuous and momentary currents, these disconnects provide proper contact integrity throughout the life of the gear for the critical primary disconnect function.

**3. CONTACT EROSION INDICATOR:** Vacuum interrupter contacts seldom wear out over the normal duty life-span of a circuit breaker. Nevertheless, a contact erosion indicator is provided for inspection convenience. It is visible when the breaker is withdrawn from the compartment.

**4. INTERRUPTER SUPPORT:** A rugged, high strength, track-resistant polyester glass support assembly firmly positions and holds the interrupter and primary conductors while providing insulation to ground and between phases. This support assembly can be removed quickly by disengaging six bolts. Only a simple alignment of the primary conductors and adjustment of contact wipe is required in the unlikely event that the interrupter assembly needs to be replaced.

**5. BREAKER MECHANISM:** Both ML-17 and ML-18 mechanisms use a spring-charged, stored-energy design that is mechanically and electrically trip-free and can be operated by dc control voltages of 48V, 125V or 250V, or ac voltages of 230V. High quality mechanism parts are precision-tooled for operating consistency, reliability, maintenance ease and long life.

**6. ROLL-IN OPTION:** A roll-in breaker designed for use in the lower compartment of indoor switchgear is available in all breaker ratings. The roll-in feature eliminates the need for a lift truck and reduces the required front aisle space. Upper compartments may be left blank or used as auxiliary compartments above 1200A and 2000A breakers. Above 3000A breakers, they must be left blank for ventilation. The breaker used for this option is the same as used for the two-high product, with the addition of a simple undercarriage, and can be made interchangeable with existing or new equipment breakers.

# THESE SUPERIOR DESIGN FEATURES ARE STANDARD ON POWER/VAC® SWITCHGEAR

**A. MAIN BUS COMPARTMENT** is completely isolated by metal barriers. Bus bars are provided with high dielectric insulation and pass through track-resistant polyester glass barriers between cubicles. All main bus joints have silver-plated connections for positive contact and low resistance, and are insulated with preformed boots (not shown in this photo). Porcelain insulation to ground is optional.

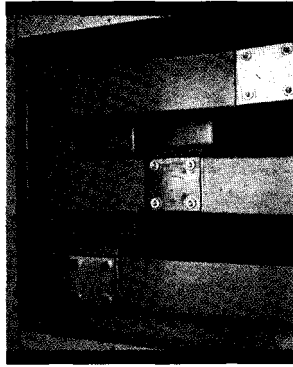

**B. SECONDARY DISCONNECTS** combine the positive-contact reliability of a plug with the automatic, self-aligning convenience of sliding-type contacts. While in the test position, secondary contacts are easily disengaged or re-engaged by a linkage operated from the front of the circuit breaker.

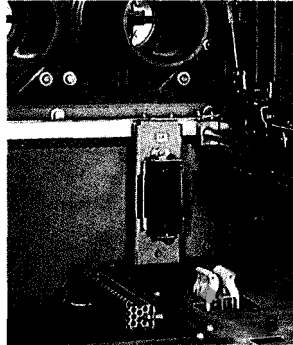

**C. CURRENT TRANSFORMERS** are typically located behind a mechanically actuated safety shutter barrier that isolates the primary disconnects as the breaker is moved into the DISCONNECT position. Two CT's per phase can be accommodated on both the line and load sides of the breaker (as many as 12 CT's per breaker). CT's are front-accessible after removal of the shutter barrier.

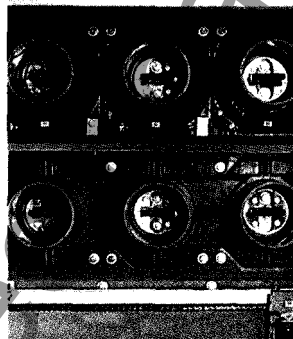

**D. VOLTAGE TRANSFORMERS** meet all applicable industry standards and are mounted in an easy-access roll-out tray.



**E. DRY TYPE CONTROL POWER TRANSFORMERS** have molded epoxy resin insulation and are mounted in a draw out tray for easy access. Ratings run through 15kVA single phase. When a higher rating, or 3 CPT's, are required, a fused roll-out tray will be supplied with stationary CPT's mounted in the rear of the unit.

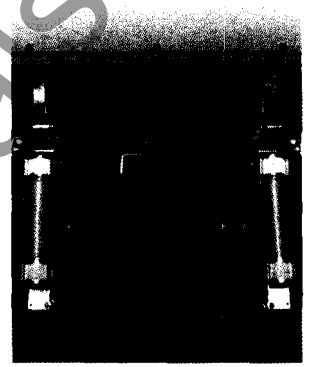

**F. CABLE COMPARTMENT** in a basic two-breaker vertical section has ample space for termination of up to two 750 MCM cables per phase, including stress cone makeup. When only one breaker is required in a vertical section, the entire cable area space is available for use.

In two-high breaker equipment, a vertical steel trough serves as a separation barrier from the other cable compartment. This duct is easily removed to facilitate initial installation of the "inside" cables. When the vertical steel duct is in place, there is still access to the "inside" terminations. The power cable compartment can be arranged to permit both sets of cables to exit below or above.

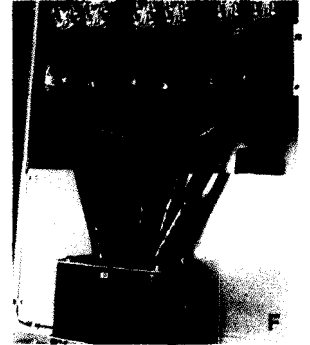

**G. PORTABLE BREAKER LIFT** is provided for handling a breaker or roll-out during installation into a compartment, or during removal for inspection or maintenance. Lifts for both indoor and outdoor equipment have interlocks on the lifting forks to lock the breaker in place during transporting.

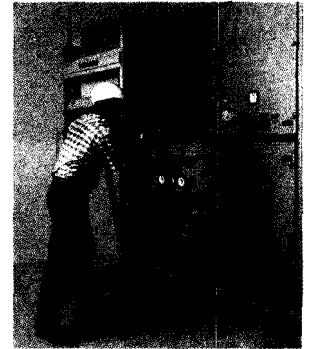

# THE INSIDE STORY ON ADDITIONAL POWER/VAC® FEATURES

**1. Two-High Breaker Stacking** can save up to 50% in floor space for most applications, depending on the rating, and results in fewer shipping splits. In addition, cubicle dimensions are the same across all ratings so space requirements are clearly defined at the outset. System planning and layout are thus simplified.

**2. Breakers Roll Along Siderails Into Position** to assure proper alignment. Positive stops are provided in TEST/DISCONNECT and CONNECT positions. Movement to the CONNECT position is accomplished with a racking mechanism that can be manually, or (as an option) electrically operated from the front of the unit with the door closed.

**3. Precision Tooling** brings uniform quality to breaker and equipment parts and facilitates trouble-free field assembly and operation.

**4. Transformer Roll-Out Trays** can be mounted in the top or bottom cubicles for greater flexibility. The transformer primaries are automatically grounded when withdrawn.

**5. A Rugged Steel Frame** employs reinforced gussets for added strength and dimensional integrity. Seismic-qualified versions are available. Grounded metal barriers isolate all high voltage compartments.

**6. Easy Installation** results because many foundations that are smooth and level don't require embedded floor steel or grouting. To reduce installation time, equipment can be lifted into place without using skids.

**7. Ample Relay and Terminal Block Space** accepts complex configurations and is compartmentalized by the front panel enclosing the breaker. Meters, relays, instruments and handles are positioned for easy reading or operation. Open doors are securely held with positive stops so breakers can be inserted and withdrawn without damaging control, indication or protective devices.

## A Full Selection of Accessories

To facilitate inspection, maintenance and test operations, General Electric offers a full selection of devices and accessories for POWER/VAC metalclad switchgear.

**A. OPTIONAL GROUND AND TEST DEVICES** are manually or electrically operated and provide facilities for grounding either the bus side or the outgoing cable side of the metalclad unit, or for "phasing out" operating circuits.

**B. TEST CABINET** provides a convenient means to close and trip breakers for maintenance or inspection.

**C. OPTIONAL REMOTE RACKING DEVICE** is portable and connects to a remote control panel via a 30 foot cable. It is motorized and electrically racks the breaker between the CONNECT and DISCONNECT positions with the door closed.

**D. RACKING HANDLE** manually operates the breaker racking mechanism to move the breaker between the CONNECT and TEST/DISCONNECT positions.

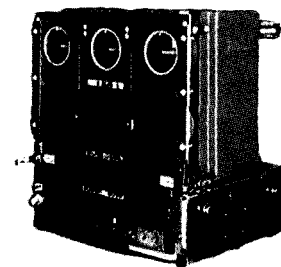
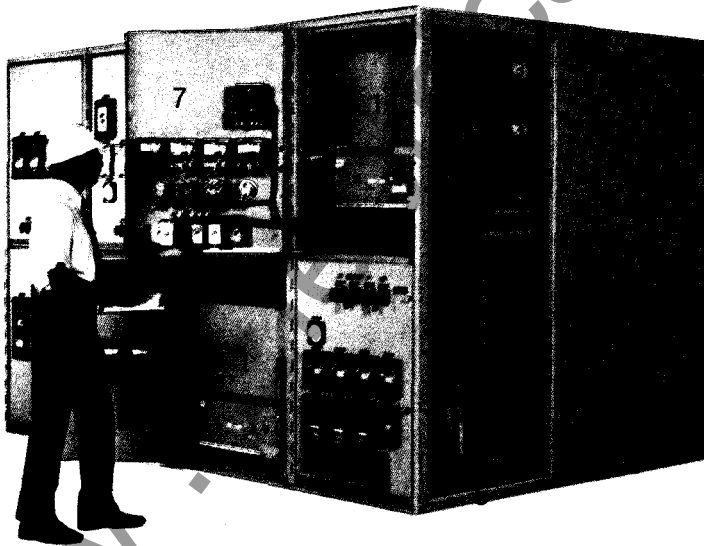

A

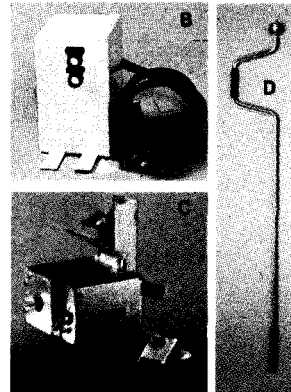

B

C

D

# THOROUGH TESTING INSURES HIGH RELIABILITY

General Electric POWER/VAC metalclad switchgear has been thoroughly tested to all applicable ANSI, IEEE and NEMA standards. Typical tests included fault current interruption, dielectric withstand, continuous current carrying, load current switching, capacitance current switching and mechanical life tests.

In addition, selected electrical tests were run in a wide range of environments which simulated field conditions. For example, mechanical operations were conducted during cold soak at  $-30^{\circ}\text{C}$  and hot soak at  $+75^{\circ}\text{C}$ . Electrical tests were conducted after high humidity soak and temperature shock cycling between  $+57^{\circ}\text{C}$  and  $+5^{\circ}\text{C}$ . And specific dielectric tests were conducted following exposure to dust and representative industrial pollutants to check insulation degradation.

This test program was carefully designed to meet or exceed pre-set reliability goals based on switchgear failure rate data in the IEEE Report on "RELIABILITY SURVEY OF INDUSTRIAL PLANTS."\* Sample sizes, test types, number of tests and required results were coordinated to provide what we believe to be the most thoroughly tested medium voltage draw-out circuit breaker ever produced.

(\*Presented May 13-16, 1973 at the IEEE Industrial and Commercial Power Systems Technical Conference.)

And the testing hasn't stopped. The on-going quality control program subjects POWER/VAC breakers to extensive mechanical endurance tests to assure they continue to exceed ANSI mechanical operation requirements.



Each breaker is pre-tested for 300 open/close operations to assure quality before the unit leaves the factory.

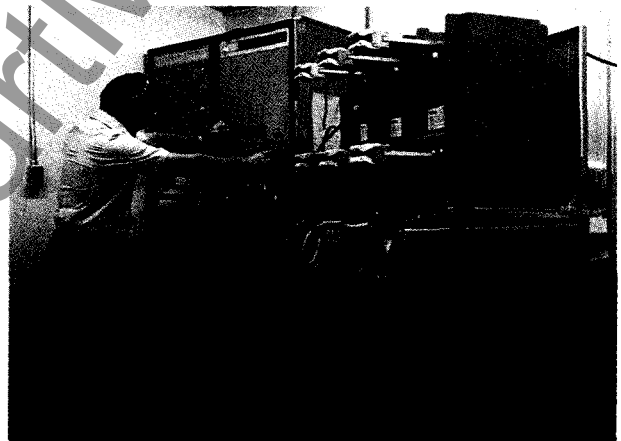

Final breaker test verifies the opening and closing characteristics of every unit. A hi-pot test is also performed on every breaker prior to shipment.

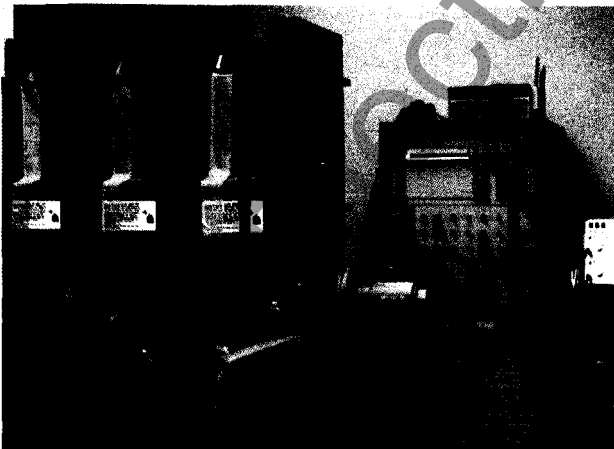

10,000-20,000 operation mechanical endurance life test is performed on one production breaker a month to assure consistent manufacturing quality.

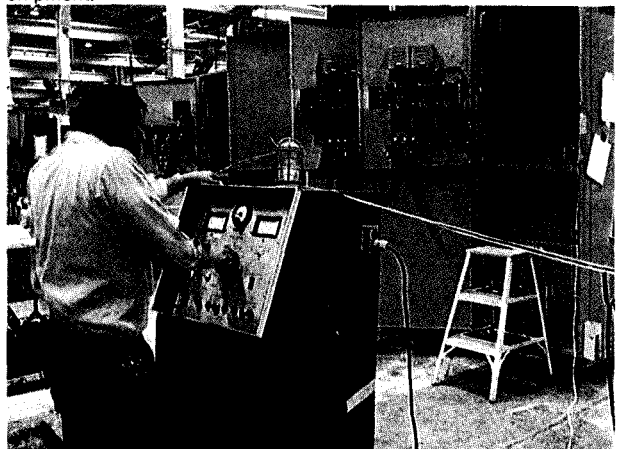

A primary dielectric test of a fully assembled line-up is conducted prior to shipment in accordance with ANSI standards.

# MORE TESTING AND MORE EXPERIENCE MEAN LESS MAINTENANCE, LESS OFTEN

**NO CONTACT MAINTENANCE** because the contacts are sealed in a vacuum-tight environment free from contamination.

**DIRECT READING CONTACT EROSION INDICATOR** — While contact erosion should not exceed allowable limits during the service life of a breaker under normal operation, a contact erosion indicator is provided and can be inspected when the breaker is withdrawn. This erosion indicator, unlike those on some other brands of switchgear, provides for a direct reading, eliminating the possibility of a misleading reading.

**CONTACT WIPE ADJUSTMENT** is infrequent, usually not before 5000 operations have occurred (more than a lifetime for most breakers). If required, however, the adjustment can be done without disassembling the breaker.

**VACUUM INTEGRITY** can be confirmed by conducting a 5 second hi-pot test on each vacuum interrupter. Test voltage is applied to the breaker primary conductors with the interrupter contact in the open position (see photo).

**TEN-YEAR MAINTENANCE RECOMMENDATION** — Based on testing and high reliability figures from the first five years of experience, General Electric began recommending a 10 Year Preventive Maintenance Schedule, effective for switchgear shipped after May 1, 1982 and operating under service conditions in a mild environment.\* It is not a guarantee or a warranty, but a recommendation for preventive maintenance. Users remain responsible for determining their own maintenance policies and inspection routines.

(\*see GEA 11108)

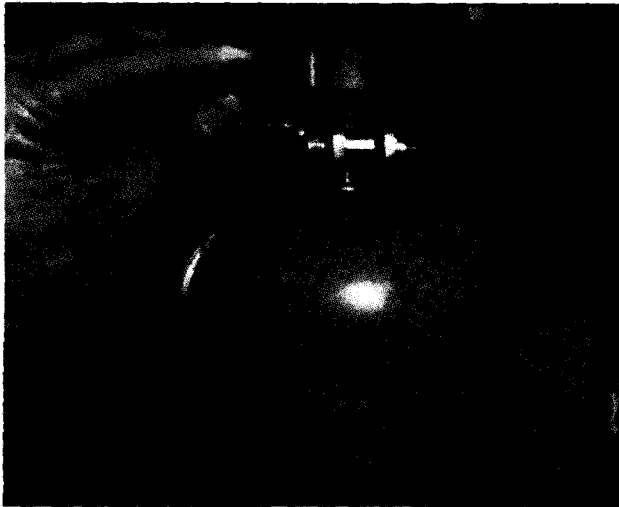

Mechanism Coupling Clamp

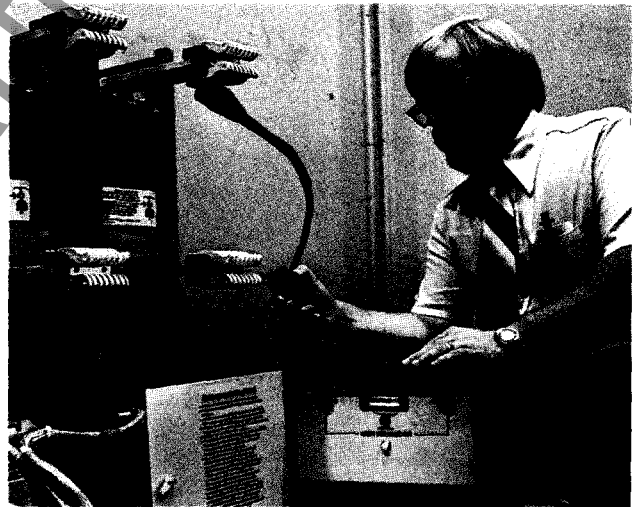

Vacuum Integrity Test

Circuit Breaker Rated Maximum Voltage (kV)	Insulation		Corona Tests*
	Rated Withstand Test Voltage		Minimum allowable corona extinction rms voltage** (Line-to-ground) (kV)
	Low Frequency, rms, hi-pot test (kV)	Crest Impulse (kV)	
4.76	19	60	3.5
8.25	36	95	5.5
15.00	36	95	10.5
Success Criteria	No flashover or insulation puncture	No flashover or insulation puncture	Corona extinction occurs above allowable voltage

\*Corona tests not required by industry standards  
\*\*CSA C22.2 #31 — 1972

Dielectric test requirements for POWER/VAC Metalclad Switchgear.

# INTEGRATED MANUFACTURING IN ONE LOCATION

From the proposal stage to the time POWER/VAC switchgear is shipped, the entire manufacturing process takes place in a single location: the General Electric facility in Burlington, Iowa. This means that the most rigorous quality control can be maintained at all

times. In addition, the most technically advanced design and manufacturing procedures are used in the production of POWER/VAC metalclad switchgear. Here are a few of the reasons for POWER/VAC's superiority.

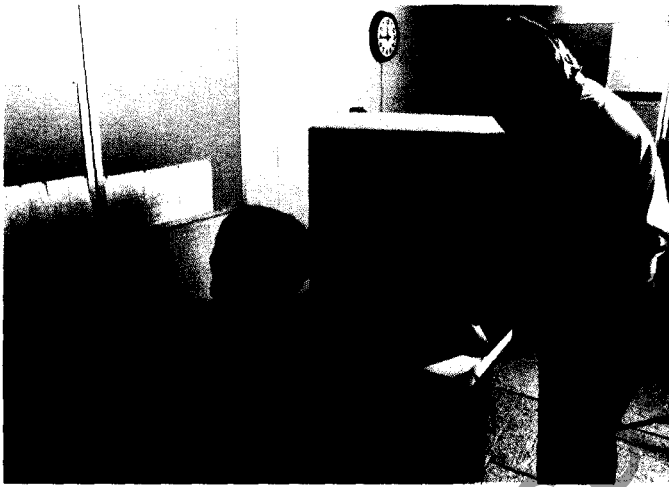
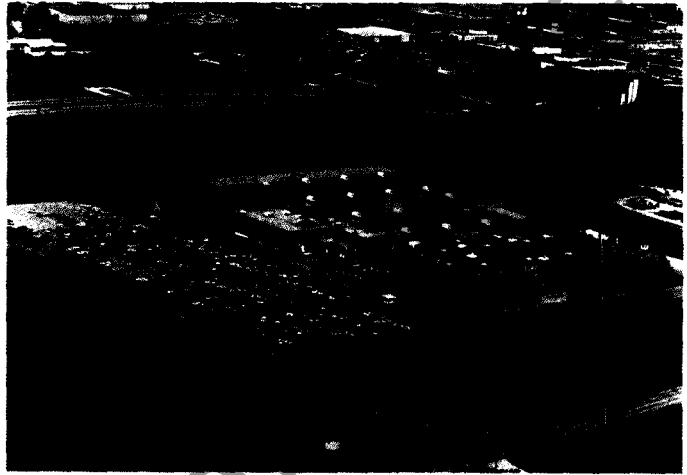

Computer generated documentation increases the accuracy of prints, which are integrated into the manufacturing cycle of your POWER/VAC switchgear. These computer generated drawings likewise aid your installation and maintenance personnel.



Vertical machining center represents state-of-the-art technology, is numerically controlled and capable of holding a part position and repeatability tolerance of .001. In less than 10 seconds, it automatically changes to one of 24 different tools to perform a variety of machining functions.



Numerically controlled machines meet the stringent requirements of GE switchgear design engineering.



Fluidized bed process coats bus bars, connection bars, and some barriers with a tough epoxy coating known for its high dielectric strength (450 volts per mil), low moisture absorption and high impact resistance.

# THE WORLD'S MOST SOPHISTICATED MANUFACTURING FACILITY

The cathodic electrodeposition ("E Coat") paint system ensures a tough, durable finish on every square inch of the switchgear enclosure and other fabricated parts.

After cleaning, phosphating and sealing, parts are immersed in the paint tank where they receive an epoxy coat .7 to .8 mils thick.



Parts pass through a bake oven ensuring a tough finish, and return to the staging area prior to assembly.



The paint system is closely monitored to ensure consistent quality.

Highly reliable POWER/VAC vacuum interrupters are produced in the state-of-the-art vacuum interrupter manufacturing facility.

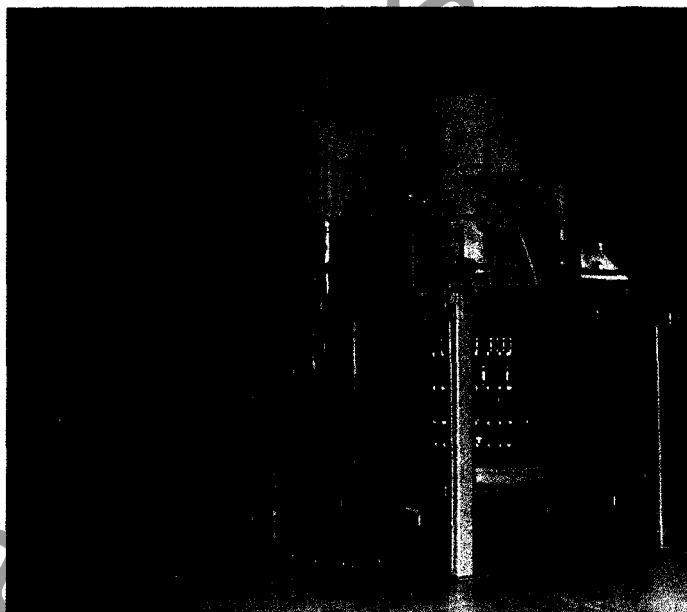

The custom-built vacuum furnace creates the vacuum and seals the assembled interrupter.

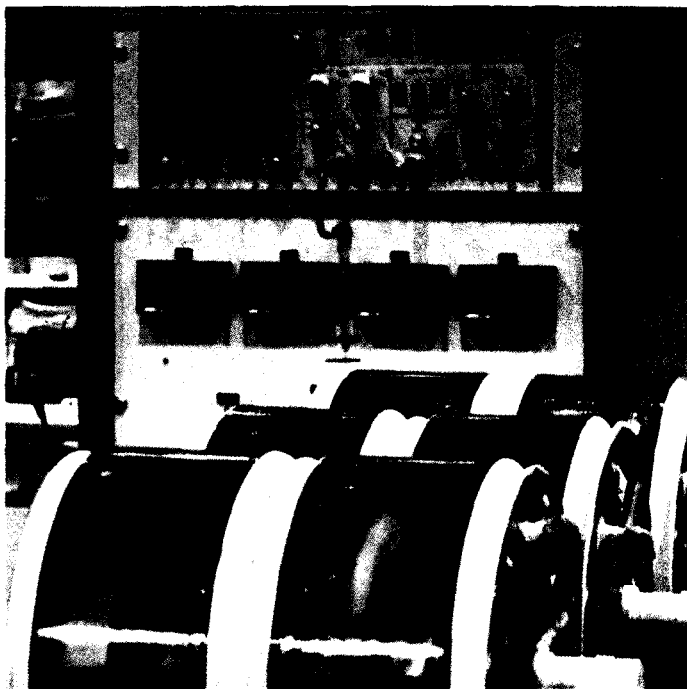

A magnetron test verifies the vacuum integrity of every interrupter. Capable of measuring pressures to  $10^{-8}$  torrs, it utilizes a magnetic field to produce ion current flow which is proportional to the pressure within the interrupter. Each interrupter is checked three times before shipment.

# RATINGS, WEIGHTS & DIMENSIONS

Breaker Type	Current Rating (Amperes)	Breaker Weights	Indoor						Outdoor (For common aisle construction, add 1500 pounds to weight of 2 indoor vertical sections)								Indoor and Outdoor		
			Height	Depth	Breaker Vertical Section (Less Breakers)		Auxiliary Vertical Section		Height	Depth	Breaker Vertical Section (Less Breakers)		Auxiliary Vertical Section		For Protected Aisle. Add To Each Vertical Section		Rollout Weight (PT-CPT)	Required Clearance	
					Width	Weight	Width	Weight			Width	Weight	Width	Weight	Depth	Weight		Front Aisle Min.	Rear Aisle Min.
VB-4.16-250	1200	550	95	94*	36	3100	36	3100	111 or 112 (see below)	101 or 176 or 267 (see below)	36	3600	36	3600	75	1100	500	66**	26
	2000	650																	
VB-4.16-350	1200	550																	
	2000	650																	
VB-7.2-500	1200	550																	
	2000	650																	
VB-13.8-500	1200	550																	
	2000	650																	
VB-13.8-750	1200	550																	
	2000	650																	
VB-13.8-1000	1200	550																	
	2000	650																	
	3000	780																	

\*An optional 82" depth is available for some applications if limited to one breaker per vertical section.  
 \*\*58" minimum front aisle space available for indoor.

## Weights and Dimensions—Breakers and Equipment

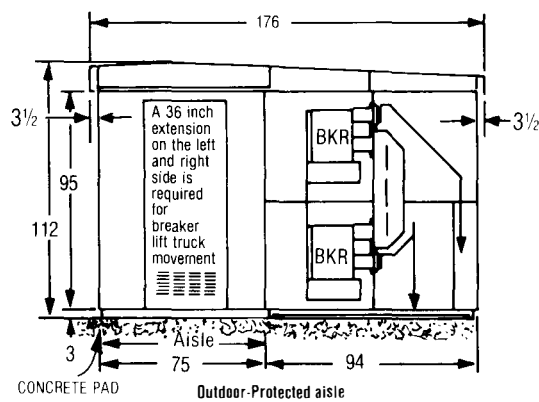
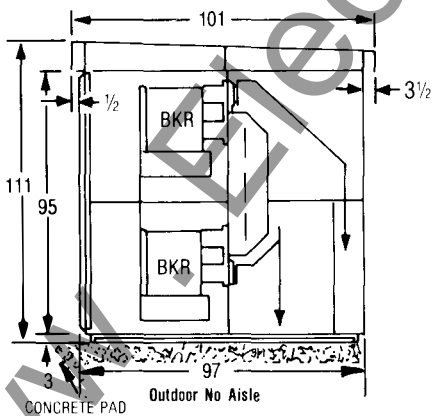
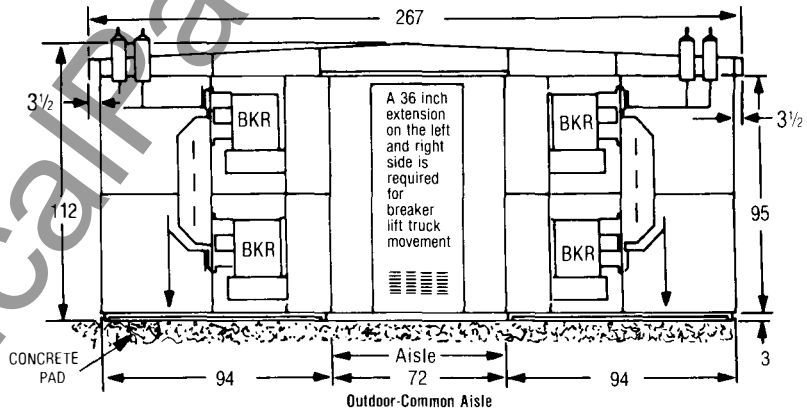
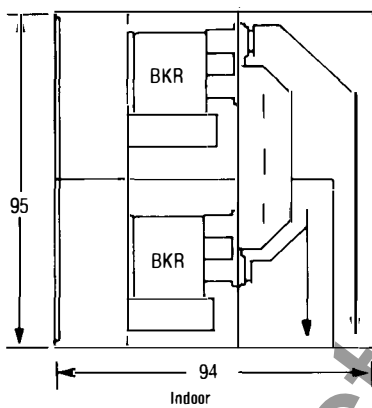

## Typical Section Dimensions—Indoor and Outdoor Equipment

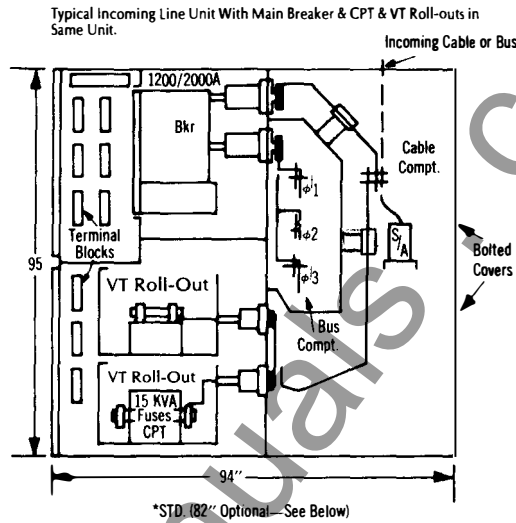
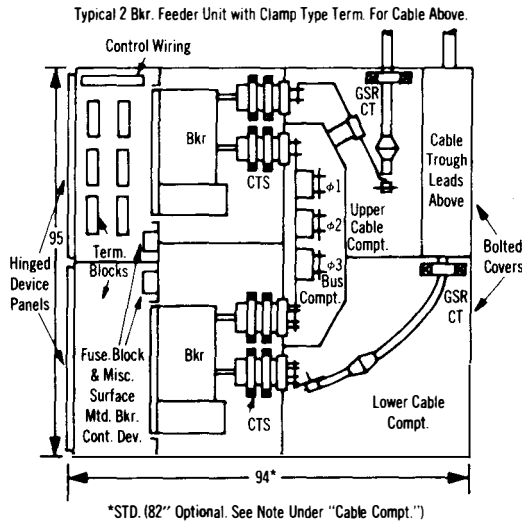

- BUS COMPARTMENT**
- 1200A and 2000A: Aluminum standard; copper optional.
  - 3000A bus is copper only.
  - Bus supports designed for 80,000A momentary.
  - All joints connected with 2 bolts and booted.
  - Bus support insulation system:
    - Non-tracking polyester glass (std. 5 kV)
    - Porcelain inserts (std. 15 kV)
    - Fluidized bed epoxy bus insulation.

- CABLE COMPARTMENT**
- Designed for up to 2-750 MCM/Ø per breaker; cables above or below.
  - CT's with greater than ANSI accuracy must be mounted in cable compartment and may limit such cases to one breaker per vertical section.
  - Stress cone space of 21 inches is provided and use of preformed stress cones, such as GE Terminatic (TM), is recommended.
  - Certain simple cable compartment configurations such as clamp type terminations for one moderate-sized cable per phase, with or without Ground Sensor, permit a unit depth of 82 inches on indoor units.

## Typical Equipment Section Views

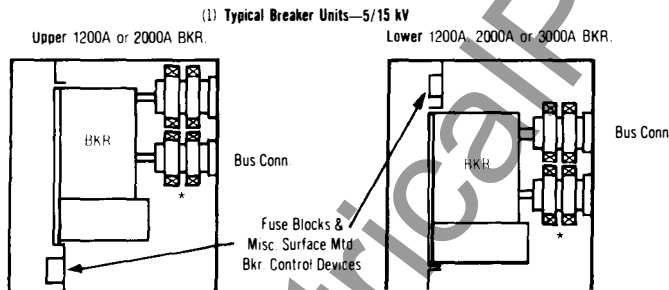

\*Space for 4CTS Per Phase. 2 on Upper Studs & 2 on Lower Studs. Rating Range: 150A-4000A Accuracy Per ANSI C37.20, Table 6

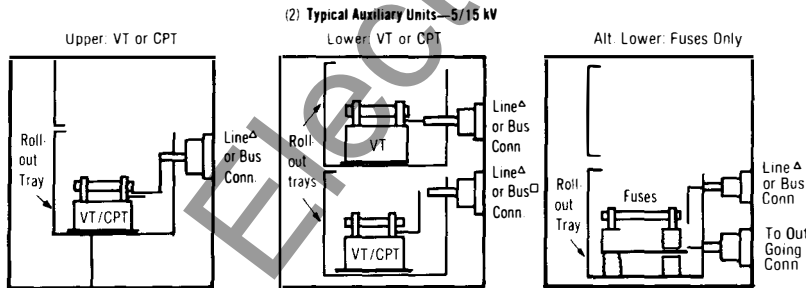

**VT Accommodations**  
 2 L-L (2 Fuses Each)  
 3 L-N (1 Fuse Each)  
**CPT Accommodations**  
 Up to 15 kVA 1 Ø with 2 Fuses  
 ▲ Line Connected to Breaker in Same Vertical Section.  
 □ Provided VT Roll out in same compartment is bus connected or is omitted.

Fuses for 3 Ø CPT or 1 Ø CPT > 15 kVA.  
 CPT and secondary breaker located in Cable Compartment.

## Available Unit Combinations

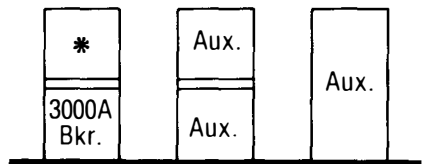
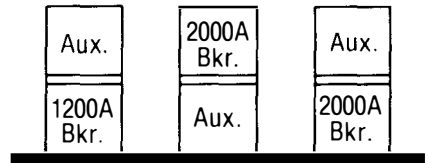
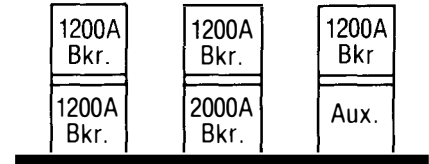

Note: Above combinations for 3000A bus max.

\* No breakers or roll-out trays permitted here

## Typical Upper and Lower Unit Configurations

# POWER/VAC Circuit Breaker Characteristics

## Symmetrical Rating Basis ANSI C37.06 (1979)\*

Identification (6 & 7)		Rated Values							Related Required Capabilities				
Nominal rms Voltage Class (kV)	Nominal 3-phase Class (MVA)	Voltage		Insulation Level		Current		Rated Interrupting Time (Cycles)	Rated Permissible Tripping Delay, Y (Seconds)	Rated Maximum rms Voltage Divided by K (kV)	Current Values		
		Rated Maximum rms Voltage (kV) (1)	Rated Voltage Range Factor K (2)	Rated Withstand Test Voltage		Continuous rms Current Rating at 60 Hz (amperes)	Short circuit rms Current Rating (at Rated Max kV) (kA) (3) (4)				Maximum Symmetrical Interrupting Capability (5) (kA)	3 Sec Short-time Current Carrying Capability (kA)	Closing and Latching Capability rms Current (kA)
				Low Frequency rms Voltage (kV)	Crest Impulse Voltage (kV)								
4.16	250	4.76	1.24	19	60	1200	29	5	2	3.85	36	36	58
4.16	250	4.76	1.24	19	60	2000	29	5	2	3.85	36	36	58
4.16	250	4.76	1.24	19	60	3000	29	5	2	3.85	36	36	58
4.16	350	4.76	1.19	19	60	1200	41	5	2	4.0	49	49	78
4.16	350	4.76	1.19	19	60	2000	41	5	2	4.0	49	49	78
4.16	350	4.76	1.19	19	60	3000	41	5	2	4.0	49	49	78
7.2	500	8.25	1.25	36	95	1200	33	5	2	6.6	41	41	66
7.2	500	8.25	1.25	36	95	2000	33	5	2	6.6	41	41	66
7.2	500	8.25	1.25	36	95	3000	33	5	2	6.6	41	41	66
13.8	500	15	1.30	36	95	1200	18	5	2	11.5	23	23	37
13.8	500	15	1.30	36	95	2000	18	5	2	11.5	23	23	37
13.8	500	15	1.30	36	95	3000	18	5	2	11.5	23	23	37
13.8	750	15	1.30	36	95	1200	28	5	2	11.5	36	36	58
13.8	750	15	1.30	36	95	2000	28	5	2	11.5	36	36	58
13.8	750	15	1.30	36	95	3000	28	5	2	11.5	36	36	58
13.8	1000	15	1.30	36	95	1200	37	5	2	11.5	48	48	77
13.8	1000	15	1.30	36	95	2000	37	5	2	11.5	48	48	77
13.8	1000	15	1.30	36	95	3000	37	5	2	11.5	48	48	77

\*Numbers in parentheses refer to the notes, below

## Non-Standard Breakers — High Close and Latch Capability

4.16	250	4.76	1.24	19	60	1200 2000	29	5	2	3.85	36	36	78
13.8	500	15	1.30	36	95	1200 2000	18	5	2	11.5	23	23	58
13.8	750	15	1.30	36	95	1200 2000	28	5	2	11.5	36	36	77

1. Maximum voltage for which the breaker is designed and the upper limit for operation.

2. K is the ratio of rated maximum voltage to the lower limit of the range of operating voltage in which the required symmetrical and asymmetrical interrupting capabilities vary in inverse proportion to the operating voltage.

3. To obtain the required symmetrical interrupting capability of a circuit breaker at an operating voltage between 1/K times rated maximum voltage and rated maximum voltage, the following formula shall be used:

Required Symmetrical Interrupting Capability =  

$$\frac{\text{Rated Short-circuit Current X (Rated Max. Voltage)}}{\text{(Operating Voltage)}}$$

For operating voltages below 1/K times rated maximum voltage, the required symmetrical interrupting capability of the circuit breaker shall be equal to K times rated short-circuit current.

4. With the limitation stated in 5.10 of ANSI-C37.04 1979, all values apply for polyphase and line-to-line faults. For single phase-to-ground faults, the specific conditions stated in 5.10.2.3 of ANSI-C37.04-1979 apply.

5. Current values in this column are not to be exceeded even for operating voltages below 1/K times rated maximum voltage. For voltages between rated maximum voltage and 1/K times rated maximum voltage, follow (3) above.

In accordance with ANSI-C37.06, users should confer with the manufacturer on the status of various circuit breaker ratings.

6. General Electric POWER/VAC circuit breakers are designated as type VB - "KV" - "MVA". For example, this breaker is type VB -4.16 - 250.

7. NOTE: General Electric reserves the right to improve the design and/or modify the specifications in this publication without notice.

©1988 General Electric Company



For further information, call your local GE sales office, or write:  
 GE Electrical Distribution & Control  
 41 Woodford Avenue  
 Plainville, Connecticut 06062

Outside the U.S.A., write:  
 GE Electrical Distribution & Control Export Operation  
 411 Theodore Fremd Avenue  
 Rye, New York 10580, U.S.A.

