

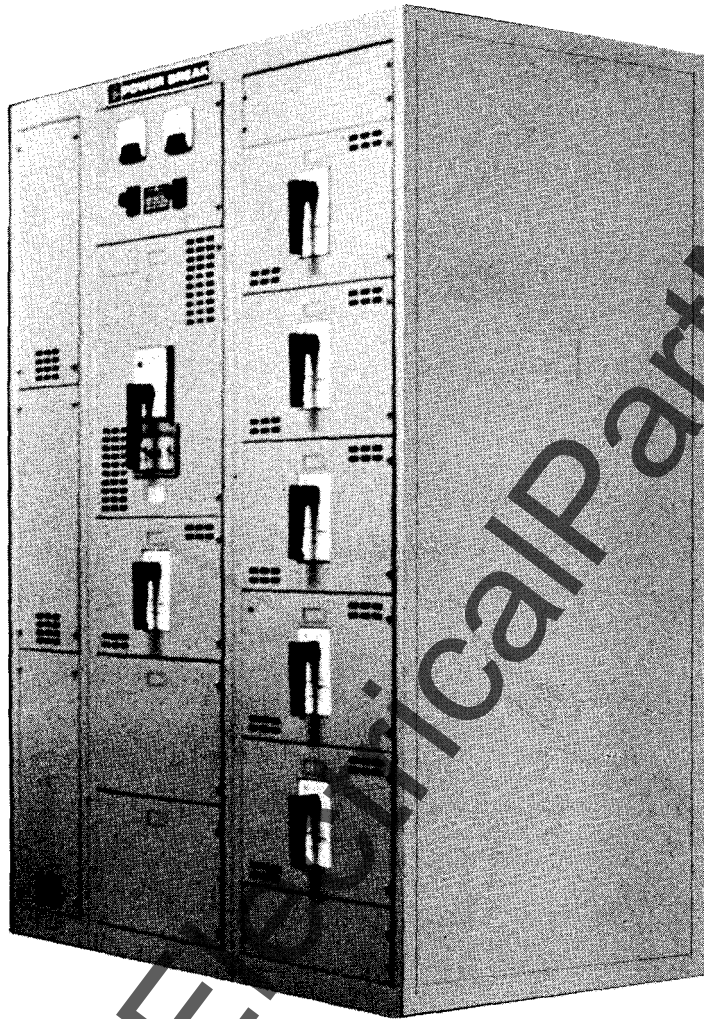

INSTALLATION AND MAINTENANCE INSTRUCTIONS POWER-BREAK™ SWITCHBOARDS



TYPICAL POWER-BREAK SWITCHBOARD

TABLE OF CONTENTS	PAGE
RECEIVING, HANDLING, STORAGE	
Receiving	2
Handling	2
Storage	2
Lifting Instructions	2
INSTALLING THE SWITCHBOARD	
Prior To Installation	3
Switchboard Location	3
Foundation Requirements	4
Incoming Line Connections	4
Cabling	4
Bolting	4
Electrical Clearances	4
Grounding	4
Ground Fault Protection	4
Handling Devices	5
Wiring The Switchboard	5
Installing Splice Bus	6
Installing Bus Stub	7-9
Installing Unit Barriers	10
Removing and Installing Breakers	11
DRAWOUT ASSEMBLY	
Description	12
Electrical Disconnects	12
Movable Carriage/Breaker Positions	12
Mechanical Interlocks	12
Secondary Contacts	12
Padlocking	12
Operation	13-14
Mechanical Details	15-16
PERIODIC MAINTENANCE PROCEDURES	
Drawout Assembly	17
Trip Interlock Checkout	17
Indicator Adjustment	17
Lubrication	18-19
Switchboard	20
Maintaining The Bus System	20
Ambient Temperatures	21
Circuit Loading	21
Arcing Damage	23
Watersoaked Equipment	23
Spare Parts	23

These instructions do not purport to cover all details or variations in equipment nor do they provide for every possible contingency to be met in connection with installation, operation or maintenance. Should further information be desired, or should particular problems arise which are not covered sufficiently for the purchaser's purpose, the matter should be referred to the General Electric Company.

RECEIVING, HANDLING AND STORAGE

RECEIVING

Before leaving the factory, the switchboard is given a final inspection and packed by workmen experienced in the proper handling and packing of electrical equipment. Upon receipt of any apparatus, an immediate inspection should be made for any damage sustained in transit. If damage is noted, or indication of rough handling is visible, a claim for damage should be filed with the carrier. Information as to damaged parts, part number, case number, requisition number, etc., should accompany the claim.

In regard to claims for damaged shipments, shortages and incorrect material, the following is an excerpt from the Published Supplemental Terms and Conditions of Sale for products of the Distribution Assemblies Department, General Electric Company.

"Title and risk of loss shall pass upon delivery of the products to the carrier at the f.o.b. point and invoices shall be payable without deduction for losses in shipment. It is the Purchaser's responsibility to file claims with the carrier for loss or damage in transit."

"Claims for shortages or incorrect material must be made in writing within 30 days after receipt of the shipment by the Purchaser, and the failure to give the Company such written notice within the 30-day period shall be unqualified acceptance of the products and a waiver by the Purchaser of all claims for shortages or incorrect material."

HANDLING

Equipment may be moved into position by means of construction rollers under the shipping skids. Remove all outer packaging. Lifting by crane or other hoisting methods should be performed as shown in Figures 1 and 2. Sections and bus are disconnectable for entry thru restricted passageways.

To remove the POWER-BREAK Switchboard from the skids after taking out the shipping bolts, carefully slide the equipment so that the rear side is off the skids, resting on the floor (Fig. 3). Tilt the entire equipment slightly to the rear to release the skids. Caution is advised in sliding and tilting this equipment due to its height and weight. It can become top heavy if tilted too far. Slide the switchboard into place by pushing on the frame. Vacuum out any dust or loose particles of packing material which may have collected on the device parts. Remove all protective blocking on relays, devices or breakers.

STORAGE

If it is necessary to store the equipment for any length of time, the following precautions should be taken to prevent corrosion or breakage:

1. Uncrate equipment.
2. Store in a clean, dry, rodent-free area in moderate temperature. Cover with a suitable canvas to prevent deposits of dirt or other foreign material on movable parts and electrical contact surfaces. (Heavy duty plastic covers are recommended.)
3. If stored in cool or damp areas, heat should be provided to keep the equipment dry. On outdoor switchboards this may be accomplished by making a temporary power connection to the heaters installed in the equipment. On indoor switchboards, two standard 120 volt lamps rated at 100 watts can be used inside each vertical section.

CAUTION: Remove all cartons and other miscellaneous packing material from inside the units before energizing any heaters.

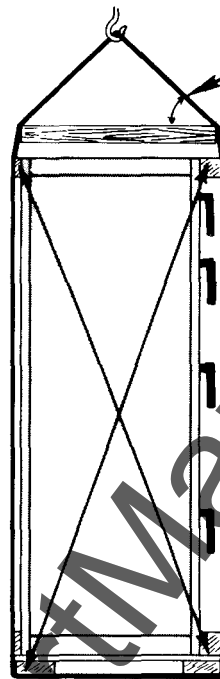

FIGURE 1.

Using lifting slings, spreader and blocking which are not furnished with equipment.

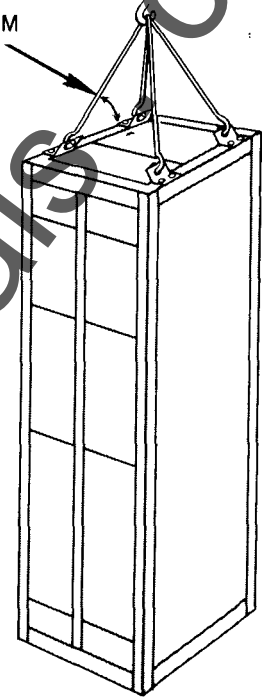

FIGURE 2.

Using lifting plates, angles or beams which are furnished with equipment.

LIFTING INSTRUCTIONS

1. Do not pass cables or ropes through support holes.
2. Always use load rated shackles or safety hooks in support holes.
3. Rig so that legs of sling (Figs. 1 and 2) are no less than 45° from horizontal.

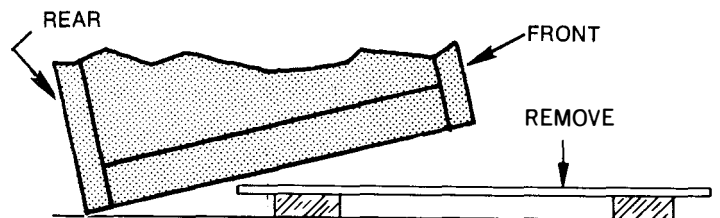
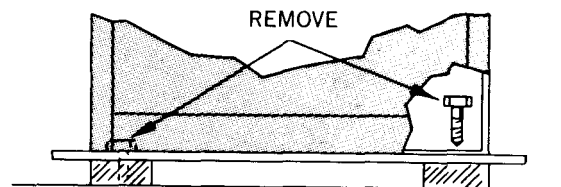

FIGURE 3.

Remove lag bolts. Slide unit off skid and remove skid.

INSTALLING THE SWITCHBOARD

PRIOR TO INSTALLATION

Before any installation work is performed, study all drawings furnished by the General Electric Company for the particular installation. These include arrangement drawings (front, end, and plan view), connection diagrams and schedule of equipment. Any material external to the equipment which may be required to meet any local codes, (mats, screens, railing, etc.), is not furnished.

LOCATION

In locating the switchboard, consideration should be given to the aisle space required. The space at the front must be sufficient to permit the opening of doors, and the insertion and withdrawal of removable breakers. The space at the rear must be sufficient for access to the cable compartments. Information for door openings is furnished on job drawing. Check local codes for special aisle space requirements.

FOUNDATION REQUIREMENTS

Indoor Equipment—The floor or foundation must be strong enough to prevent sagging from the weight of the switchboard structure. If the foundation is subject to vibrations, special mounting must be provided to prevent the transmittal of vibrations to the equipment.

Because of its high structural strength, the POWER BREAK Switchboard may be bolted directly to the floor. See Fig. 4. The floor must be entirely level without any high spots which might cause misalignment. If the floor is not level it is recommended that floor channels be used.

The steel floor channels when used should be embedded in a concrete slab with the top surface of the channels flush with the finished floor. To avoid distortion of the structure, it is essential that the steel channels be level and aligned with each other prior to the final anchoring. The recommended foundation construction and method of mounting the switchboard to the foundation is shown in Fig. 5. Channels should be grouted after installation.

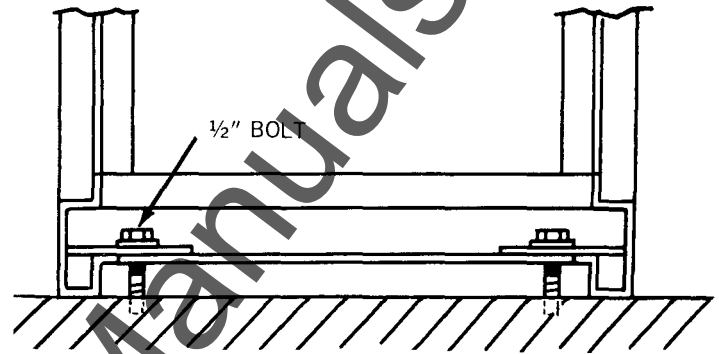

FIGURE 4.

Bolting the switchboard directly to the floor—indoor construction.

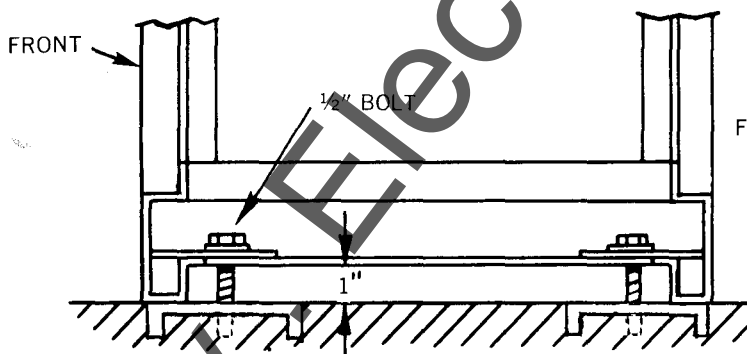

FIGURE 5.

Switchboard mounted on grouted floor channels—indoor construction.

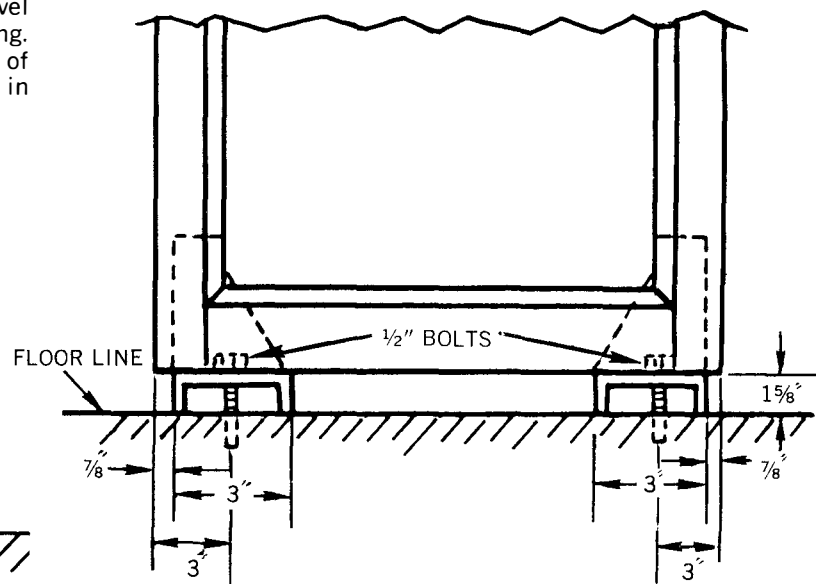

FIGURE 6.

Alternate floor channel mounting channels must be level—indoor construction.

INSTALLING THE SWITCHBOARD

FOUNDATION REQUIREMENTS (cont.)

An alternate mounting method is to secure the switchboard to floor channels mounted on the floor. (See Fig. 6). The channels, or the switchboard, must be leveled by shimming.

Outdoor Equipment—Outdoor equipment is usually installed on a concrete pad with a level and smooth surface. Channel sills are supplied with the switchboard, two with the non-walk-in type and three for the walk-in type as shown in Figs. 7 and 8. Channels should set on the pad and be filled with grout.

Conduits—At the time the foundation channels are being installed, any conduits or sleeves required for power and control cables that are to enter the equipment from underneath should be located and installed within the available space shown on the floor plan drawings. Consideration should be given to installing conduits or sleeves which might be required for future connections. Conduit stubs should extend above the floor just enough to prevent the entrance of water. Consideration should be given to the location of components in the switchboard and space should be allowed for swinging cables after they leave the conduit. The lowest live metal part in the switchboard will be approximately 8" minimum above the bottom of the switchboard (not including floor sills). It should be noted that the switchboard must be lifted over the conduit stubs. The conduits should terminate at the switchboard with the appropriate conduit connectors. Conduits may require grounding or electrical connection to the switchboard enclosure.

INCOMING LINE CONNECTIONS

Incoming cables and busways should be identified by phase and connected to the proper terminals. The switchboard buses are identified as phase A, B and C reading from left to right, top to bottom and front to rear. On 3-phase, 4-wire 120/240 volt delta-connected systems, connect phases so that the cable having 208 volts to neutral is connected to phase B. Single-pole circuits should not be connected to this bus.

CABLING

Cables should be bundled in appropriate groups and secured with heavy twine or nylon ties. The bundle should then be clamped to the vertical wire passages or to the structure to prevent whipping during short-circuits. Cable supports should be added where necessary so that there will be no strain on device terminals.

To prevent heating, there should be no closed loop of steel around a single conductor or group of conductors which does not include all the conductors (including the neutral) of the circuit. If conductors pass through separate holes in a piece of steel, slots should be cut between the holes.

Do not allow cables carrying heavy current to come near instruments or meters as this may affect their accuracy. Use the minimum amount of cable necessary to accomplish the connections. The increased resistance of longer cables generates unnecessary heat.

BOLTING

POWER-BREAK switchboard bus bar joints are furnished with 1/2" medium carbon steel hardware having a high tensile strength. 1/2" bolts have a tensile strength of 120,000 psi. Similar hardware should be used for any additional bolting.

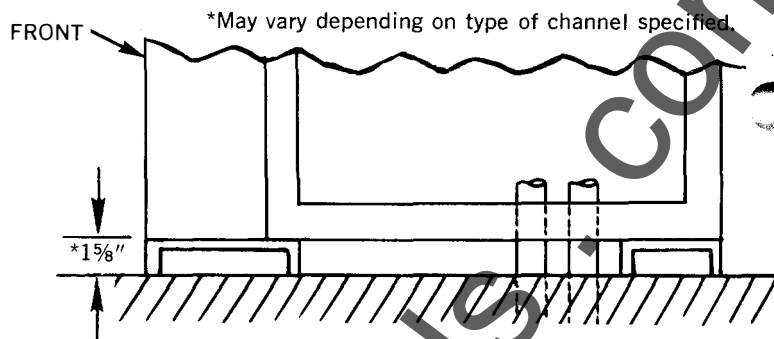

Figure 7 Non-walk in type switchboard—outdoor construction.

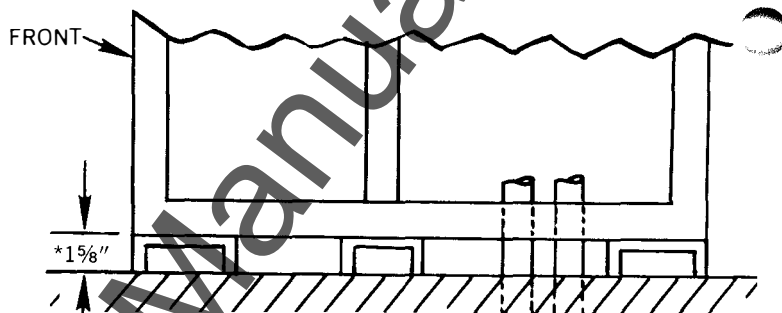

Figure 8 Walk in type switchboard—outdoor construction.

The use of a torque wrench is recommended to assure the following torques. These torques apply to aluminum or copper connections. When torquing bolts the following values are nominal:

1/4" — 20 bolts	6-8 lb. ft.
3/8" — 16 bolts	20-25 lb. ft.
1/2" — 13 bolts	50-70 lb. ft.
5/8" — 16 bolts	80-90 lb. ft.

Flat washers and spring washers should be used for all connections.

ELECTRICAL CLEARANCES

The following minimum clearances should be maintained except at terminals of circuit breakers and switches:

	0-125V	126-250V	251-600V
Between live parts of opposite polarity:			
Through air	1/2"	3/4"	1"
Over surface	3/4"	1 1/4"	2"
Between live parts and grounded metal through air or over surface	1/2"	1/2"	1"

GROUNDING

Where required, ground bus is bolted to the uprights of the rear frame. It is arranged so that connections to the station ground can be made in any unit. A ground lug is included in each complete equipment for tying the switchboard to the station ground. It is very important that the equipment be adequately grounded, to insure that all parts of the equipment, other than live parts, are at ground potential.

GROUND FAULT PROTECTION

When ground fault protection is furnished, it is important that all field connections shall be made correctly so that the ground fault protection system will function properly.

INSTALLING THE SWITCHBOARD

HANDLING THE DEVICES

Each drawout breaker is equipped with a lifting brace (Fig. 9). Optional lifting hoists are available for installing and removing breakers.

When removed from the switchboard the breaker should be placed in a vertical position on the working surface.

IMPORTANT: Do not lay breaker on rear or sides as stabs or drawout mechanism parts may be damaged.

WIRING

The POWER-BREAK Switchboard is equipped as standard with built in, protective wiring trays. (Fig 10).

Control wiring may be routed vertically and horizontally in these trays, within and between sections. (Figs. 10-13).

It is recommended that field wiring be neatly bundled and tied. Holes are available in these trays to provide tie down points for the wire ties.

All wiring holes are protected with insulated snap bushings.

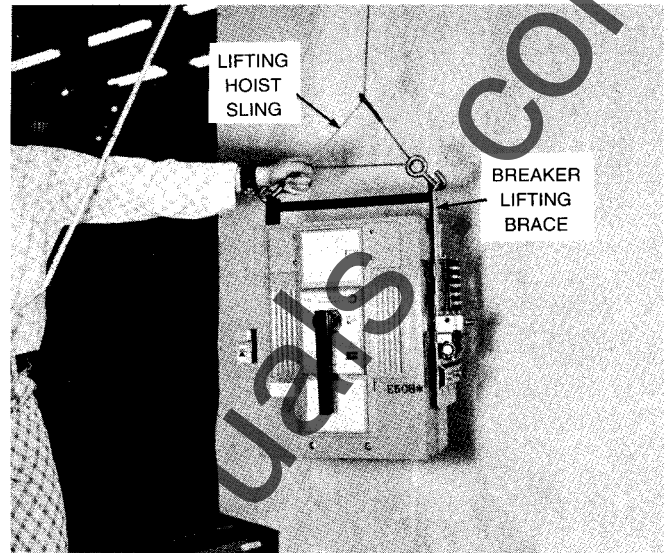

FIGURE 9.

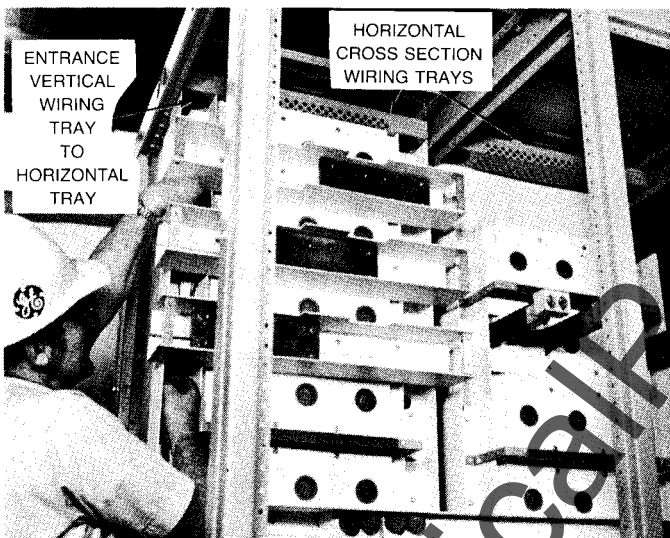

FIGURE 10.

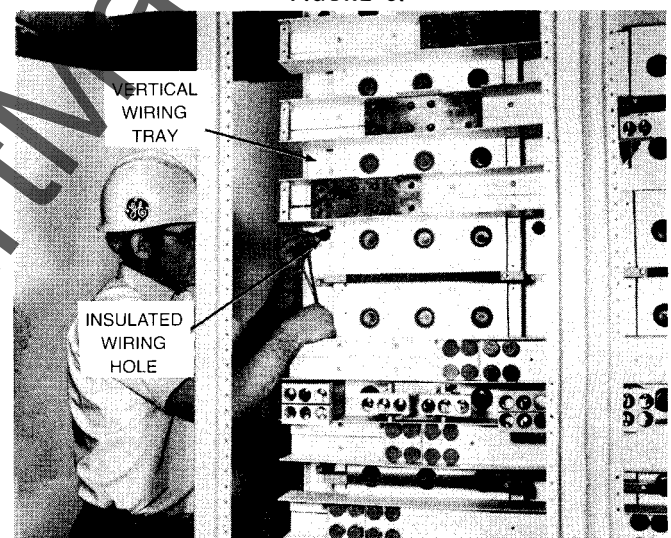

FIGURE 11.

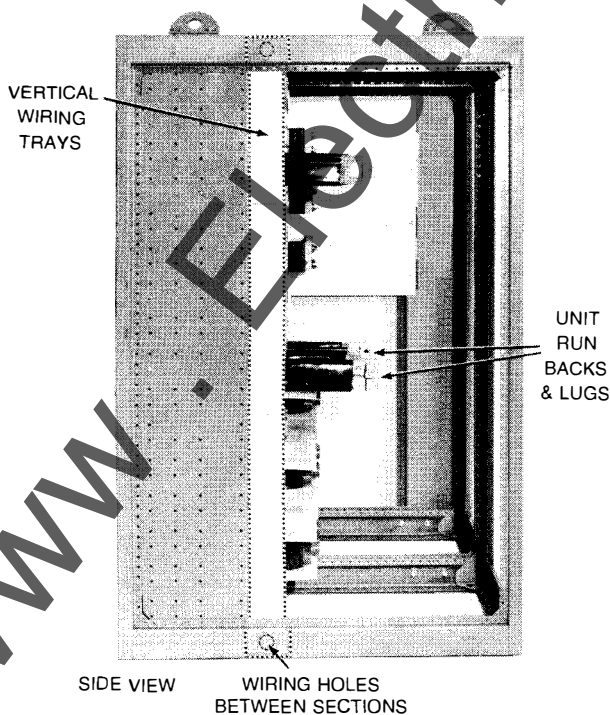

FIGURE 12.

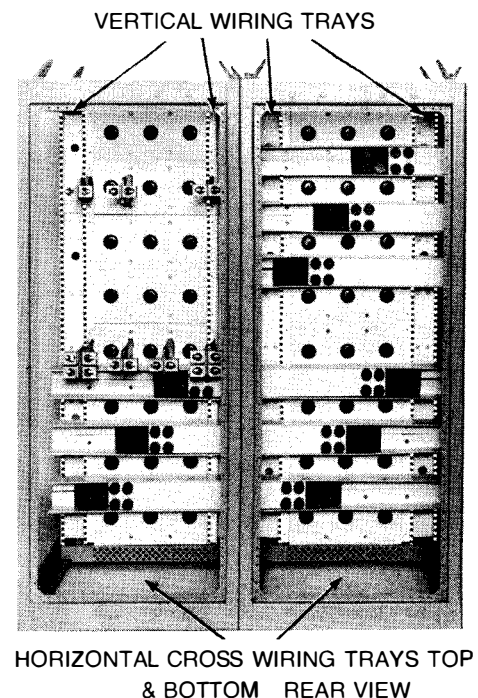

FIGURE 13.

INSTALLING THE SWITCHBOARD

INSTALLING SPLICE BUS

Field installation of main bus occurs when there is a shipping split involved or when extensions are added to in place switchboards.

To facilitate these connections the main, neutral and ground bus in each switchboard is sectionalized.

Prior to the installation of splice bus the switchboard sections must be leveled and squared off and then bolted together at the top and bottom depth posts.

It is important that the sections be drawn tightly together or the splice bus bolting hole may not line up.

Installation Procedures (See Fig. 14 for parts identification)

Step "A" Installation

1. Bolt sections together.
2. Remove joint hardware, end caps (if future extension) and joint insulating caps. (Fig. 15)
3. Remove adapter plate (if two bar system).

Step "B"

1. Install splice bus (One or two bars depending on ampere rating) (Fig. 16).
2. Re-install adapter plate (If two bar system).
3. Re-Install end caps, joint hardware and joint insulating caps. (Fig. 17)

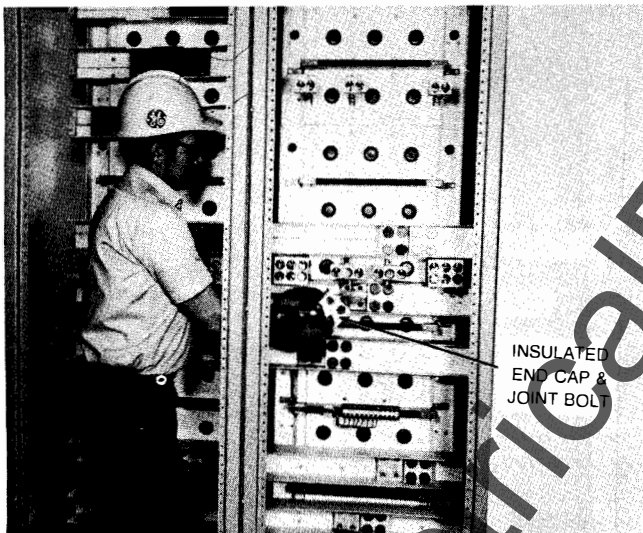

FIGURE 15.

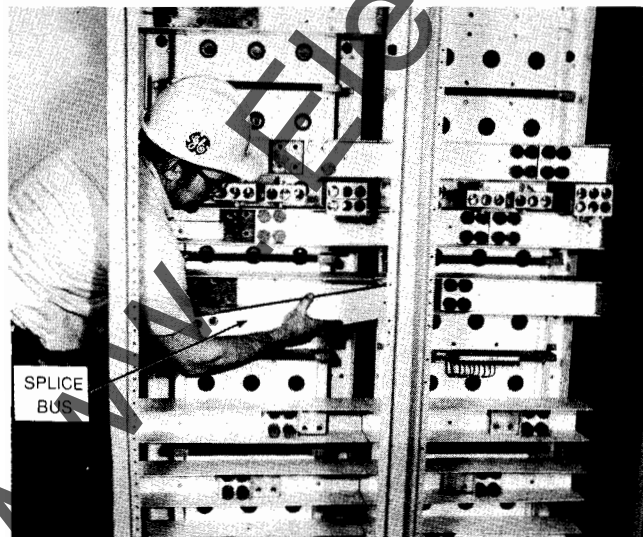

FIGURE 16.

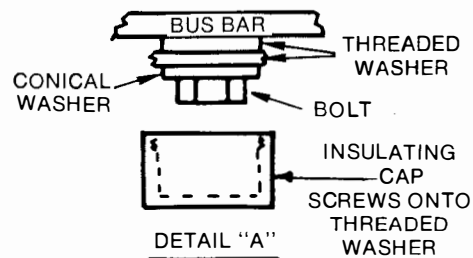
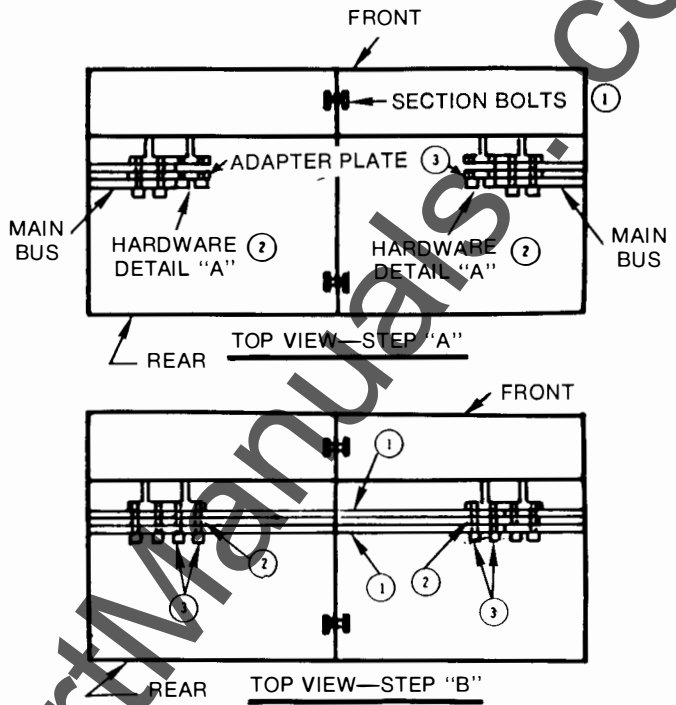

FIGURE 14.

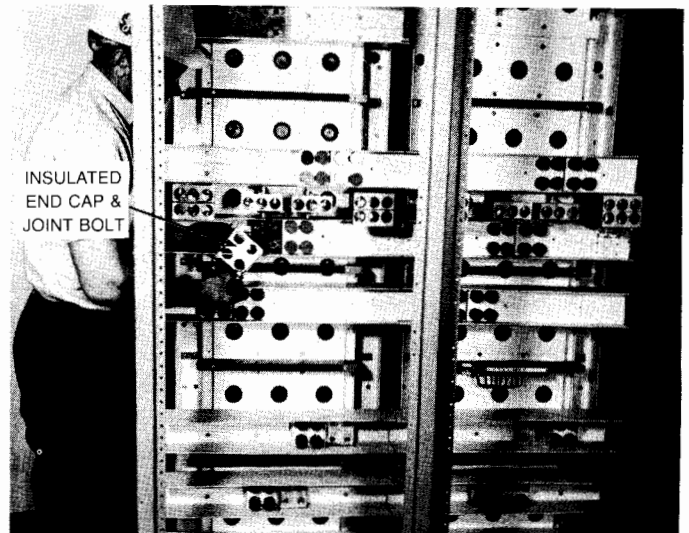

FIGURE 17.

INSTALLING THE SWITCHBOARD

INSTALLING THE ARMOR-CLAD® BUS STUB

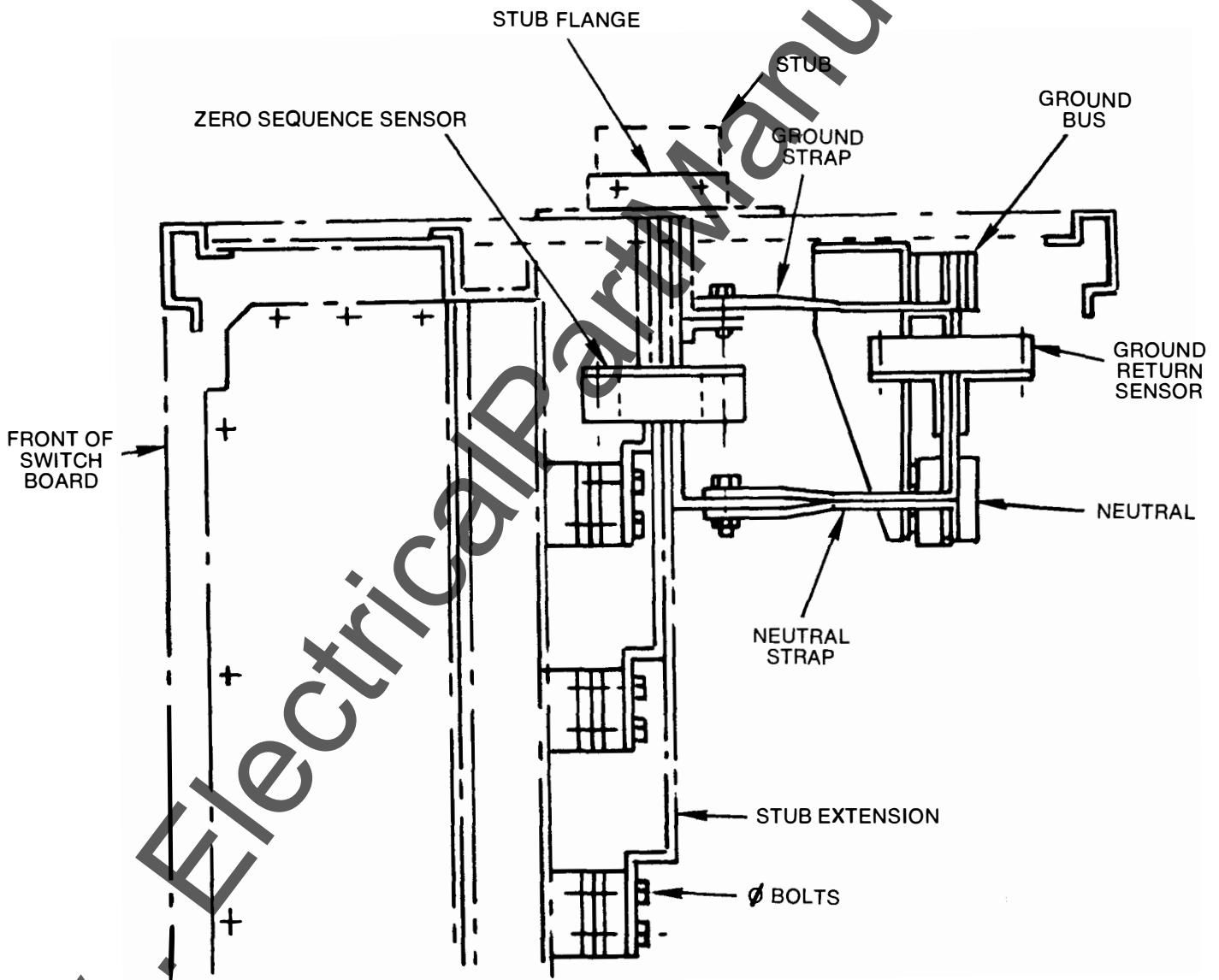
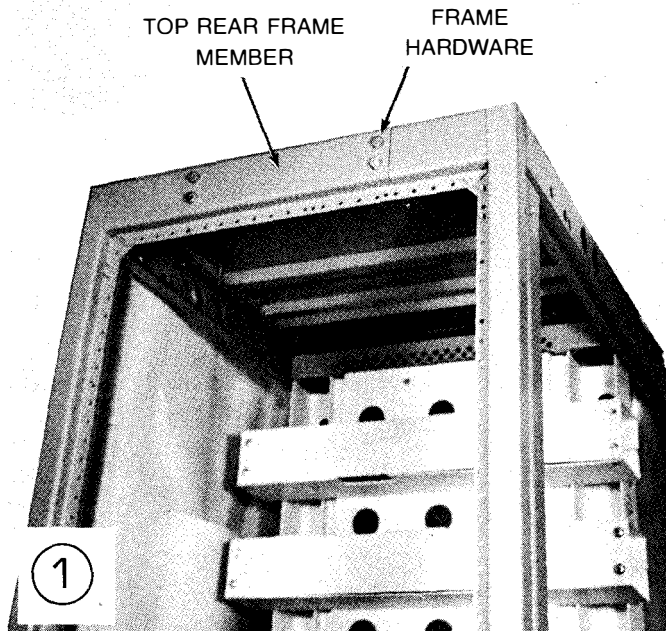

FIGURE 18. NEUTRAL GROUND BUS AND GROUND SENSOR CONNECTIONS

INSTALLING THE SWITCHBOARD

INSTALLING THE ARMOR-CLAD® BUS STUB (cont.)

If access to the switchboard bus at point of connection to the busway will be limited by a wall or other obstruction, the stub must be installed before the switchboard is placed in its final location.



STEP 1. (Fig.19)—When head space is limited, the top rear frame member is removable so that the stub can be installed horizontally instead of vertically. Where a switchboard neutral, ground bus or ground fault sensors are involved it will be necessary to remove them before proceeding with stub installation. (See Fig. 18).

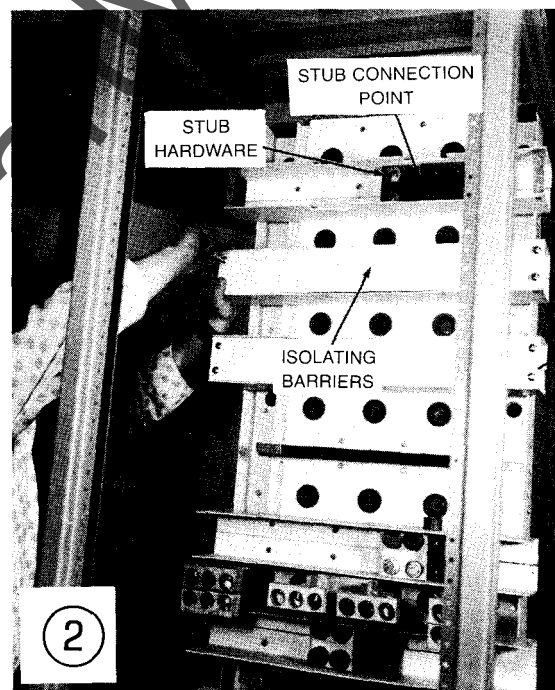

STEP 2. (Fig. 20)—Prior to installing the stub, remove the isolating barriers from the stub connection points and remove the hardware in the stub connection terminals.



STEP 3. (Fig. 21)—Remove top closure plates to allow stub insertion through the enlarged opening.

INSTALLING THE SWITCHBOARD

INSTALLING THE ARMOR-CLAD® BUS STUB (cont.)

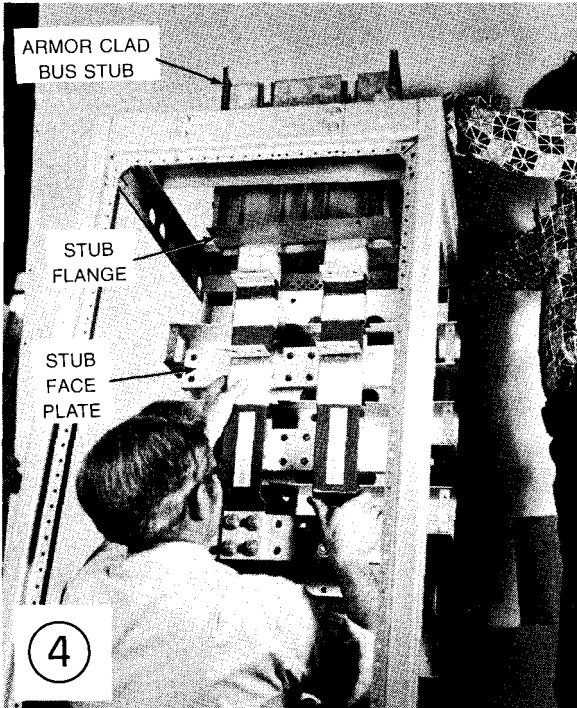

STEP 4. (Fig. 22)—Install stub through top opening. This may be done by pushing the stub up through the hole, or if a more complicated elbow type stub is involved, dropping stub in from the top of the switchboard. Install zero sequence sensor if used.

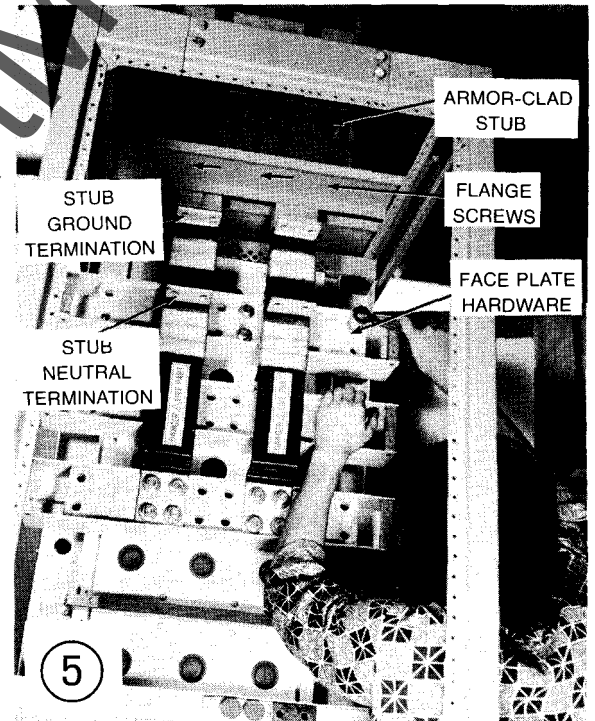

STEP 5. (Fig. 23)—With stub in place, and with holes in the stub face plate lined up over the holes in stub terminals, run bolts in loosely (using hardware removed in step 2. After all bolts are installed and stub aligned, tighten bus bolts and screws securing stub flange to top cover. Re-install ground on neutral bus.

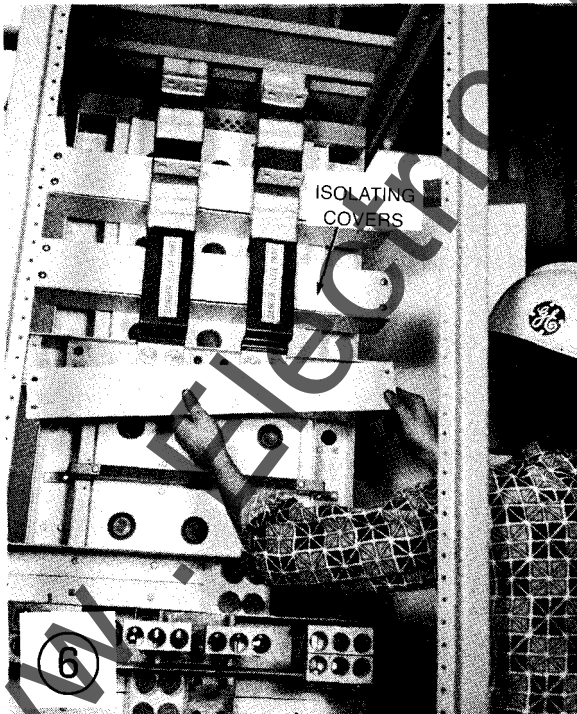

STEP 6. (Fig. 24)—Finally, reinstall top closure plates (Fig. 21), and, if involved, isolating barriers over ARMOR-CLAD bus (Fig. 20). Reinstall neutral, ground bus and sensors. See Fig. 18 for details.

INSTALLING THE SWITCHBOARD

INSTALLING UNIT BARRIERS

In the POWER-BREAK Switchboard all units are compartmentized by fixed side steel barriers and removable glass fiber polyester barriers above and below each unit.

To remove horizontal unit barriers from the front of the switchboard see Figs. 25-26.

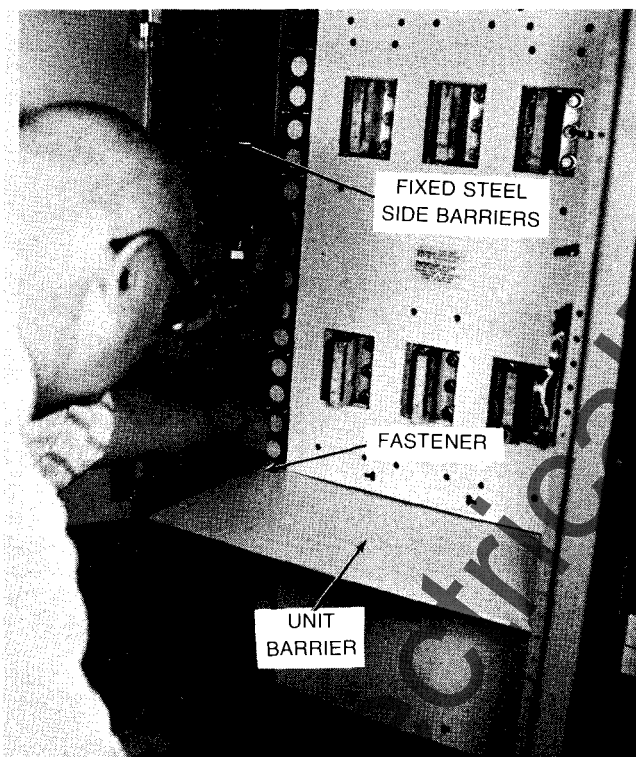

FIGURE 25. REMOVE FASTENERS WITH A SCREWDRIVER AND SLIDE THE BARRIER OUT.

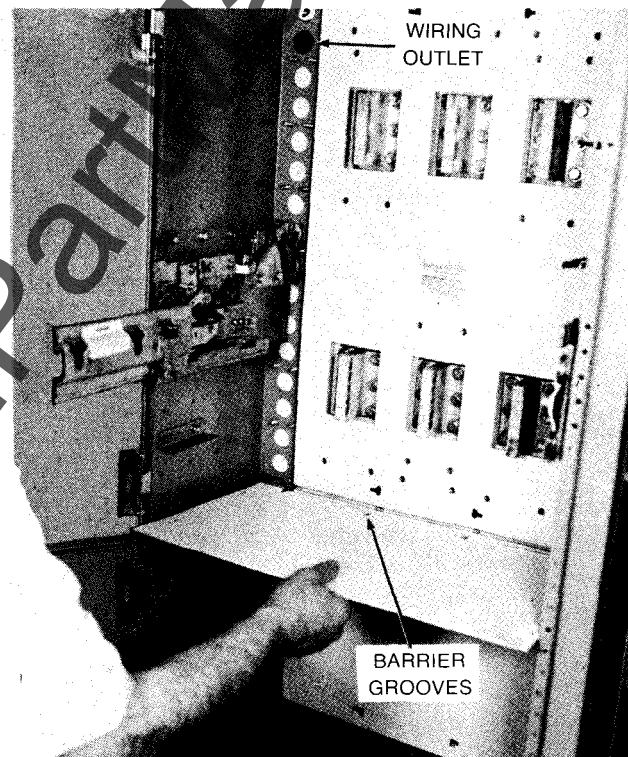

FIGURE 26. REINSERT BARRIER, MAKING CERTAIN THAT NOTCHES IN BARRIER LINE UP WITH RIBS ON UNIT BASE, AND REINSTALL FASTENERS.

INSTALLING THE SWITCHBOARD

INSTALLING STATIONARY MOUNTED DEVICES

Unit doors have removable pin type hinges. It is not necessary to remove door to install or remove devices.

Stationary mounted units are front removable.

Some devices are reverse mounted. (Line at bottom). Check label on inside of unit door.

Removing the Breaker

WARNING—HAZARD OF ELECTRICAL SHOCK OR BURN—WHEN REMOVING BREAKER SWITCHBOARD MUST BE DE-ENERGIZED.

1. Put breaker in *off* position by pushing trip button (Fig. 27).
2. Remove line shield. (Fig. 28).
3. Disconnect control wire, if present, from terminal block. (Fig. 29).
4. Remove bolts on A & C terminals. (Fig. 30).

5. **IMPORTANT** Before removing B bolts be sure that the breaker is supported by external means.

6. If breaker is to be removed and switchboard re-energized, openings in the unit door should be covered to preclude access to "hot" studs.

Installing the Breaker

WARNING—HAZARD OF ELECTRICAL SHOCK OR BURN—WHEN INSTALLING BREAKER SWITCHBOARD MUST BE DE-ENERGIZED.

1. Breaker must be in *off* position prior to installing.
2. Place breaker in unit compartment using external supporting means to hold breaker in place.
3. Line up breaker terminal holes with holes in unit line and load studs and re-install bolts. Torque bolts to valves shown on page 4.
4. Re-install line shield.
5. Reconnect control wire, if present, to terminal block.
6. Close door, re-energize board, turn breaker to *on* position.

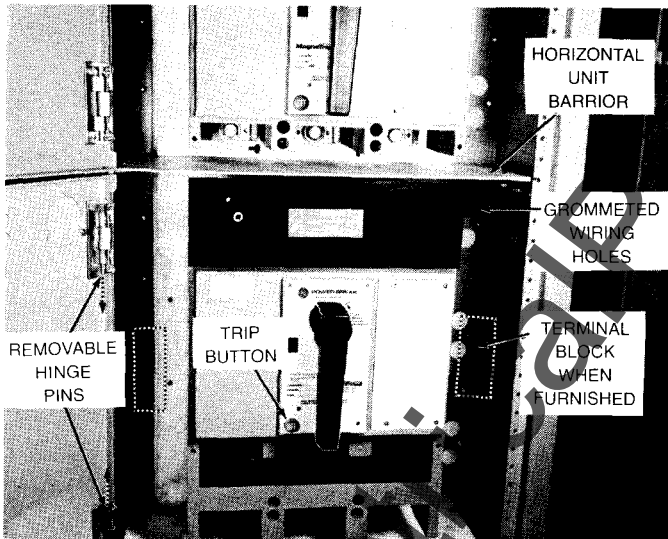

FIGURE 27.

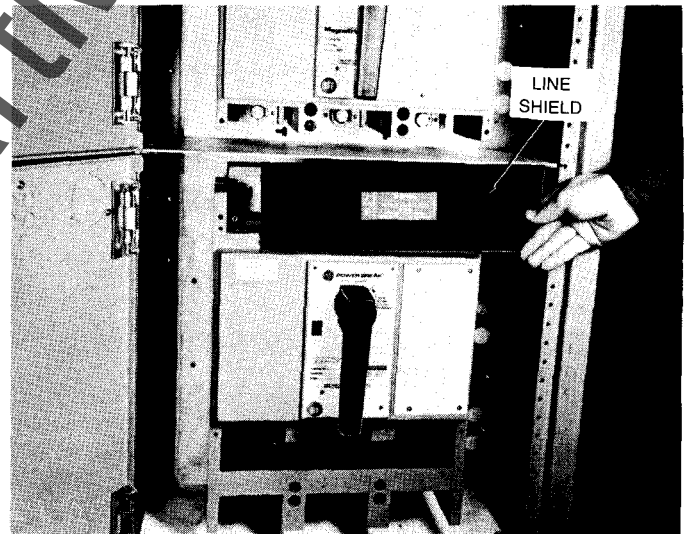

FIGURE 28.

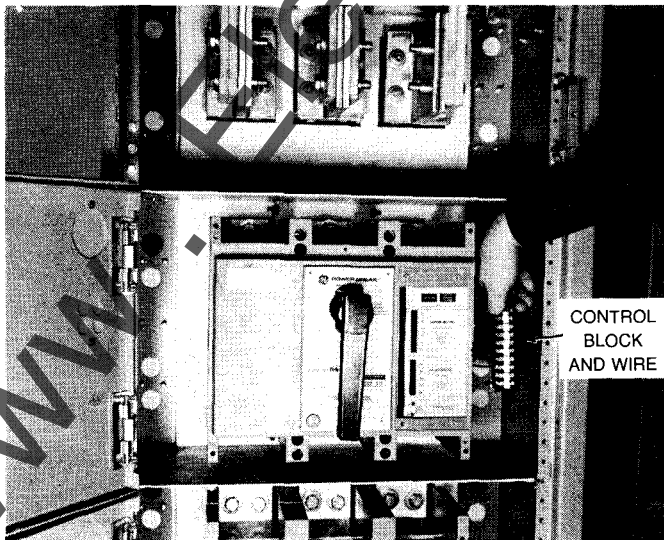

FIGURE 29.

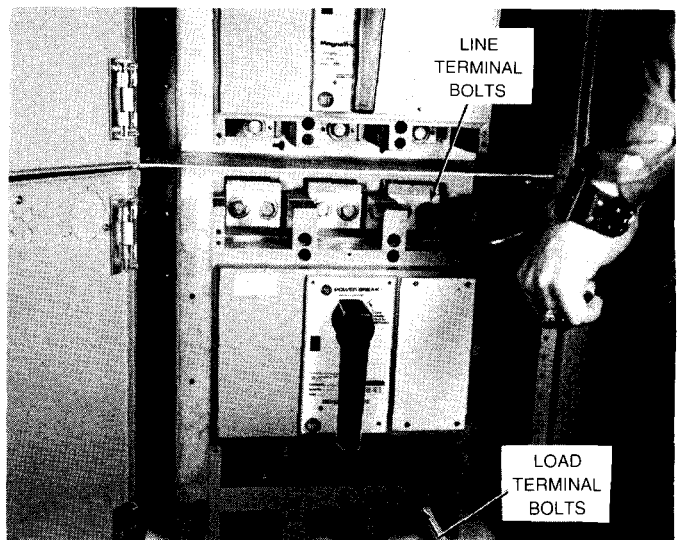

FIGURE 30.

POWER-BREAK™ DRAWOUT ASSEMBLY

(600-2500 AMPERES)

DESCRIPTION OF UNIT

The drawout assembly is a self-contained, integral unit for use in POWERBREAK switchboards providing the convenience and safety inherent in drawout type construction. It permits activation of a new feeder, rapid replacement of a circuit breaker, and facilitates inspection and maintenance of POWERBREAK insulated case circuit breakers without making it necessary to de-energize the entire switchboard.

The drawout assembly consists of a stationary frame and a movable carriage which supports the circuit breaker. Current is carried through primary disconnects which are connected to bus bars or terminal lugs for use with cable.

The movable carriage is supported by rollers riding on two sets of telescoping rails attached to the stationary frame. A crank operated screw mechanism provides the mechanical force for engaging and disengaging the primary contacts.

ELECTRICAL DISCONNECTS

The spring loaded fingers of the primary disconnects are mounted on the movable carriage and breaker assembly, permitting maintenance of the fingers without complete de-energization of the bus system. Accessory control circuits are made by means of secondary disconnects mounted within the stationary frame, with a matching set on the movable carriage.

MOVABLE CARRIAGE/CIRCUIT BREAKER POSITIONS

The design features four position operation of the movable carriage relative to the stationary frame—ENGAGED, TEST, DISENGAGED and FULLY WITHDRAWN—with the first three positions being referenced by an indicator mounted on the left side of the unit.

In the ENGAGED position primary and secondary contacts are completely engaged. In the TEST position primary disconnects are disengaged, but secondary disconnects are still engaged permitting checkout of control circuits.

In the DISENGAGED position, both primary and secondary disconnects are disengaged. The breaker is electrically disconnected from control circuits and system.

In FULLY WITHDRAWN position, the movable carriage is against the stop at the end of the rails. From this position the breaker and carriage can be removed from the stationary frame or tilted out for inspection.

MECHANICAL INTERLOCKS

- a. *Cam Gate.* Interlocking means is provided to prevent movement of the carriage from DISENGAGED to TEST position, or vice versa, with the resultant making or breaking of the secondary contacts without first manually opening the cam gates.
- b. *Breaker Trip.* Positive trip action is automatically initiated if the carriage is inadvertently cranked into or from the ENGAGED position without first opening the breaker—thus insuring that the primary contacts cannot be connected or disconnected with the breaker closed.
- c. *Rail Latch.* Spring actuated latches are provided to lock the rail assemblies in both the extended and retracted positions if the carriage is not in place. This prevents push-in of the rails until the carriage is fully installed, or roll-out of unused rails in the enclosure.

SECONDARY CONTACTS

Secondary contacts are required when the circuit breakers are electrically operated, or are equipped with auxiliary switches, VersaTrip™ neutral sensors or other control devices.

PADLOCKING

Provision is made for padlocking the carriage in the TEST or DISENGAGED position by pushing and holding a slide cover down to deny access to the mechanism screw, and to prevent movement of the carriage in either direction.

POWER-BREAK™ DRAWOUT ASSEMBLY

(600-2500 AMPERES)

OPERATION

A. To Disengage and Remove Breaker

1. With door open, use crank handle and $\frac{3}{4}$ " socket to turn mechanism screw counterclockwise as far as it will go. Indicator window will show "TEST." See Figs. 31 & 32.
2. Pull out red cam gate levers at left and right sides until they are latched. Grasp breaker, as shown in Fig. 38, and pull out to disengaged position. Cam gates will close automatically.

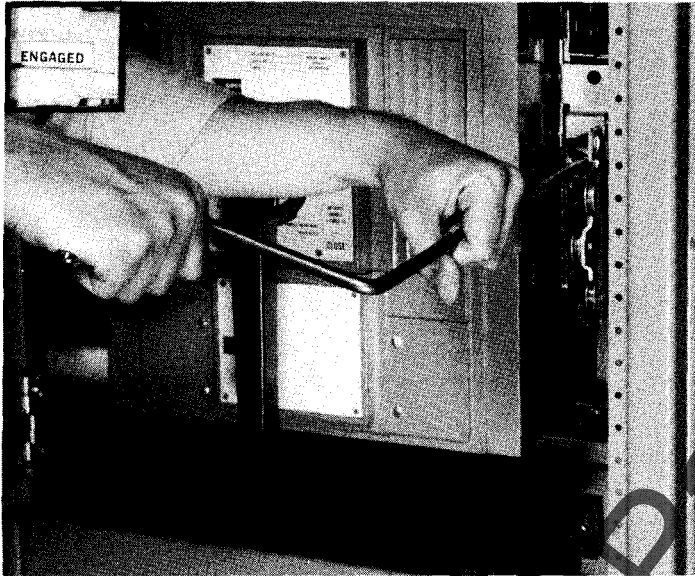

FIGURE 31.

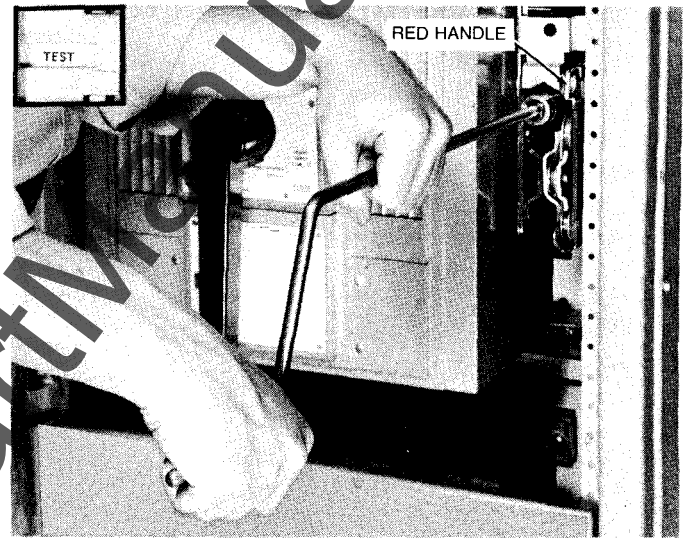

FIGURE 32.

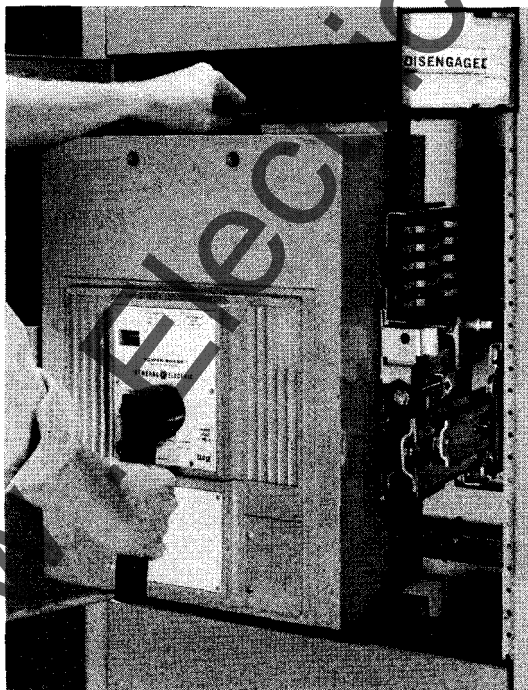
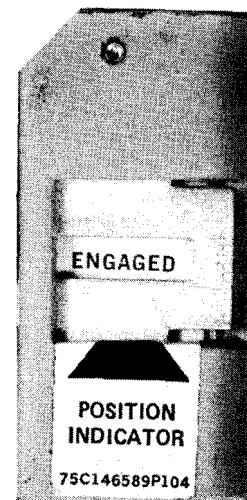

FIGURE 33.



POWER-BREAK™ DRAWOUT ASSEMBLY

(600-2500 AMPERES)

OPERATION (cont.)

A. To Disengage and Remove Breaker (cont.)

3. To inspect rear of breaker, pull it out to end of rail and rotate forward to inverted rest position. See Figs. 34 & 35.
4. If breaker is to be removed, it must be at end of rail travel in upright position where it can be raised above the rails using a portable device with a lifting sling or platform, and lowered to the floor, bench or truck.

B. To Install and Engage Breaker

1. Mechanism screw must be in full counterclockwise position, and side rails must be fully extended and latched to prevent premature pushback before positioning carriage in the rail assembly. See Fig. 36.
2. Roll breaker into DISENGAGED position against stops (See Indicator).
3. Pull out red cam gate levers at left and right sides until they are latched and push breaker into TEST position.
4. With crank and socket turn screw clockwise to ENGAGED position.



FIGURE 34. TILTING THE BREAKER

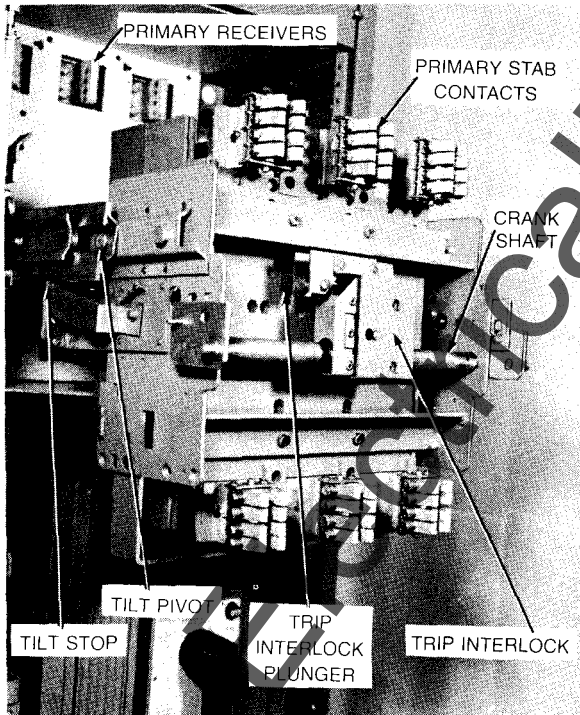

FIGURE 35. CARRIAGE IN TILT-OUT POSITION

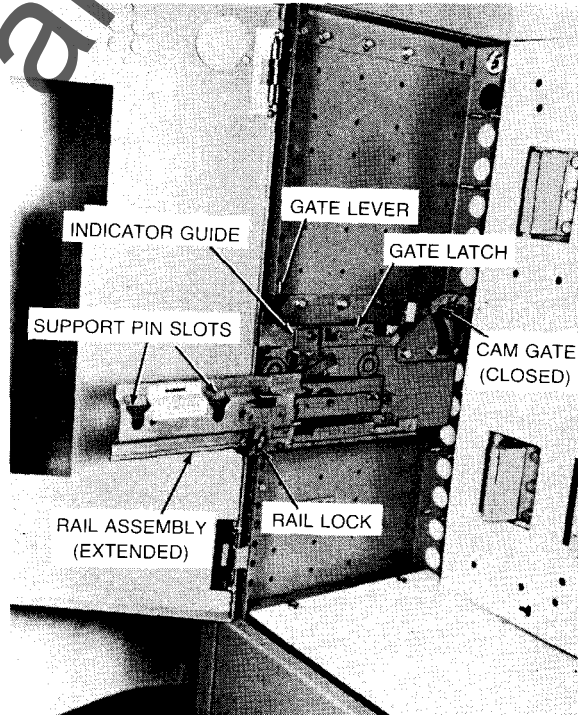

FIGURE 36. RAIL AND CAM ASSEMBLY—LEFT SIDE

POWER-BREAK™ DRAWOUT ASSEMBLY

(600-2500 AMPERES)

MECHANICAL DETAILS

Additional design features of the drawout mechanism are as follows:

Figures 37 and 38 show the right and left sides of the carriage with the crank pins located at the rear, midway between the upper and lower primary contacts. These pins, through the action of the mechanism screw and slide, rotate downward in a 90° arc and, cooperating with curved slots in the rail and cam assemblies, pull the carriage into the engaged position. Reverse action pushes the carriage back to the test position.

Figures 39 and 36 show the rail and cam assemblies at the right and left sides of the switchboard enclosure. The cams are at the rear of the assemblies. Also shown are the cam gates, (one open and one closed), which control movement into and out of the cam slots when actuated by the gate levers and latches. These latches hold the gates open when the levers are pulled out and are automatically released as the carriage passes between the DISENGAGED and TEST position in either direction.

CAUTION:

If the cam gates are operated out of sequence, the latch trigger is used to restore the cam gates to proper position. See Fig. 40.

If the cam gates are left open, the breaker will bypass DISENGAGED position energizing the secondary contacts unintentionally.

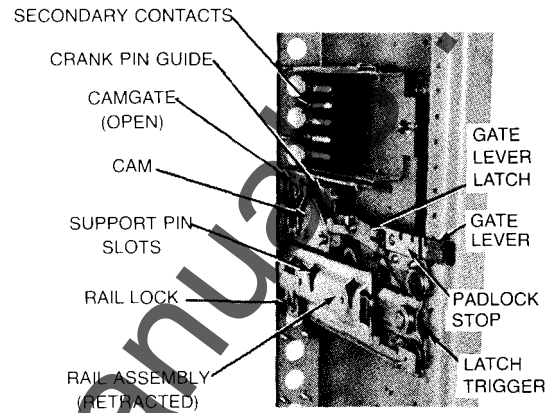

FIGURE 39. RAIL AND CAM ASSEMBLY—RIGHT SIDE

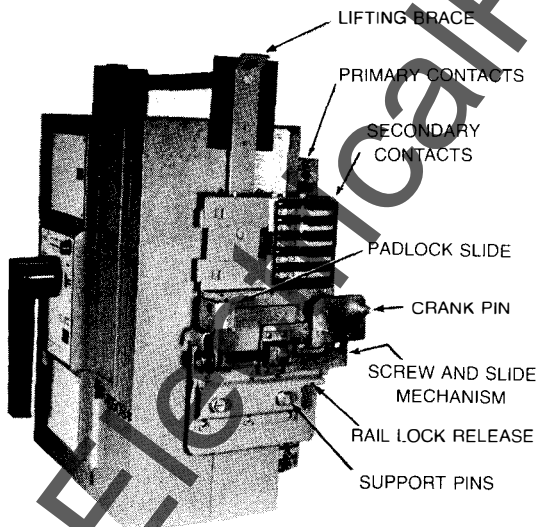

FIGURE 37. CARRIAGE ASSEMBLY—RIGHT SIDE

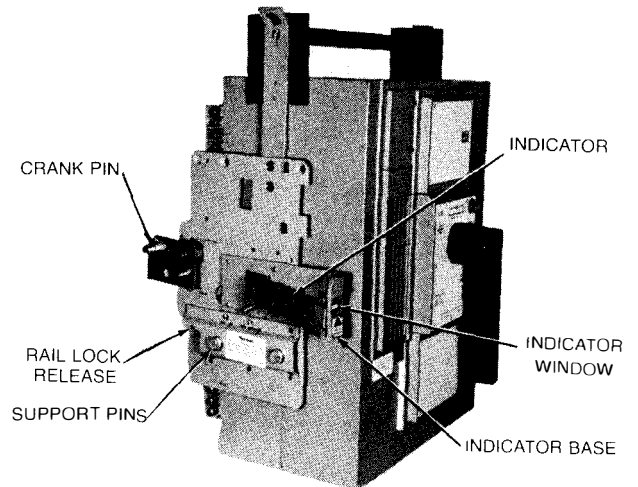

FIGURE 38. CARRIAGE ASSEMBLY—LEFT SIDE

POWER-BREAK™ DRAWOUT ASSEMBLY

(600-2500 AMPERES)

MECHANICAL DETAILS (cont.)

Fig. 41 also shows the carriage padlocked in the DISENGAGED position. A tab on the slide rests in slots in the gate lever and padlock stop (see Fig. 39) to prevent movement of the carriage or lever, while another tab covers the mechanism screw to prevent access to the screw.

Fig. 42 shows the action of the rail latch when the carriage is tilted out for inspection. As the rear portion of the carriage pin support tips up, the latch is released and pulls up into its locked position against the rail stop. The rails cannot be pushed in during the rotation, or while subsequent repair or adjustment is being performed on the breaker.

The secondary contacts shown in Fig. 39 are mounted in self-aligning steel enclosures to insure proper pick-up and continuous engagement with the mating contacts on the carriage. (Fig. 37). Contact between pairs of fingers is initiated as the carriage moves from the DISENGAGED to the TEST position and continues as the carriage is cranked in to full engagement. When the carriage is cranked out the fingers maintain contact to the TEST position so that control circuits can be checked, but become disconnected as the carriage is pulled to the DISENGAGED position.



FIGURE 40. OPERATING THE CAM GATE TRIGGER

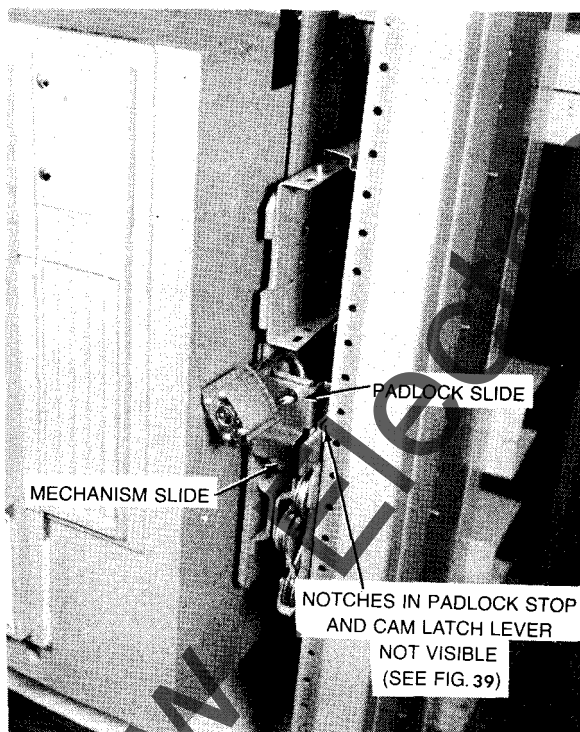

FIGURE 41.

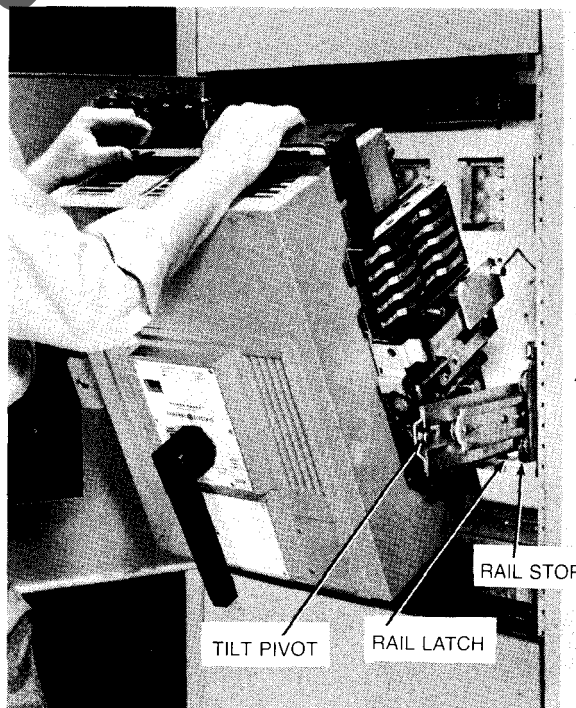

FIGURE 42. CARRIAGE AT START OF TILT OUT

PERIODIC MAINTENANCE PROCEDURES

CAUTION! De-energize equipment before performing any work.

POWER-BREAK DRAWOUT ASSEMBLY

CAUTION: Before attempting any work on drawout devices, make sure that all sources of power—primary and secondary—have been de-energized.

Drawout structure and connections should be given the following overall maintenance at least annually. The frequency of maintenance period will depend upon severity of service and atmospheric conditions around units. Equipment subject to highly repetitive operation may require more frequent maintenance.

None of the following operations should be undertaken until it is certain that equipment is completely de-energized by withdrawing breaker to disconnect or in fully withdrawn position.

Thoroughly clean by removing all dust and other accumulations from the equipment. Wipe or vacuum clean buses and supports. Avoid use of compressed air for blowing out equipment. Check indicating devices, mechanical and key interlocks for proper functioning. Lubricate all moving and rubbing parts with suitable lubricant.

Check primary and secondary disconnecting device surfaces for signs of abnormal wear or overheating. Clean contacts with suitable solvent, and apply a thin coat of the contact lubricant as described on pages 18-19. Discoloration of silvered surface is not ordinarily harmful unless atmospheric conditions cause deposits such as sulphides on the contacts.

Operate each breaker while in the TEST position to be sure it functions properly. This is particularly important for breakers that normally remain in either the opened or closed positions for long periods of time.

When the equipment is subject to unusual conditions, such as contaminating fumes, excessive moisture, etc., maintenance should be scheduled at more frequent intervals. In this case, the procedure listed above may not be sufficient for proper maintenance and additional precautions may be necessary to protect the equipment from the unusual conditions encountered.

Normal maintenance should include a visual inspection of all latches, interlocks and mechanisms with the manipulation of each one to check satisfactory performance. All screws used in the assembly should be checked for tightness.

Where needed, lubrication should be applied to all pivoting and sliding parts, with special attention being given to the mechanism screw, crank pins and cam slots which provide the force needed to insert the unit into the ENGAGED position.

While some of the above can be done with the carriage in the tilt out position, a complete check can be made only after removing the carriage and breaker from the rails.

TRIP INTERLOCK CHECKOUT

The following procedure will permit checkout of the trip interlock mechanism without energizing the breaker:

1. Bring carriage to extended position at end of rails. (May also be done on bench.)
2. Put breaker in closed position and use crank, turning clockwise as if to bring mechanism to its engaged position.
3. Breaker should trip after not more than 16 turns of the crank, and after completion of remaining turns, it should be possible to close breaker again.
4. Turning the crank counterclockwise should trip the breaker after no more than 16 turns, and when in the test position, breaker can be closed again.

NOTE: Screw must be in full counterclockwise position before pushing carriage to disengaged position again.

INDICATOR ADJUSTMENT

Means have been provided for adjusting the position of the indicator target should misalignment occur.

1. Roll carriage out to fully extended position and tilt out to rest position if desired.
2. Make sure the two indicator guide screws (Fig. 43) are tight, then back off both screws $\frac{1}{4}$ turn.
3. Bring carriage to upright position, then push in to disengaged position and—after pulling cam gate levers—to the test position.
4. a. If target is too low, insert screwdriver blade in lift tab slot, pry against roll in front of tab and raise target to proper position.
b. If too high, hold screwdriver vertically with blade on top edge of tab and tap with hammer until target drops into position.
5. Bring carriage out to extended position and tighten screws—upper one first, then lower.

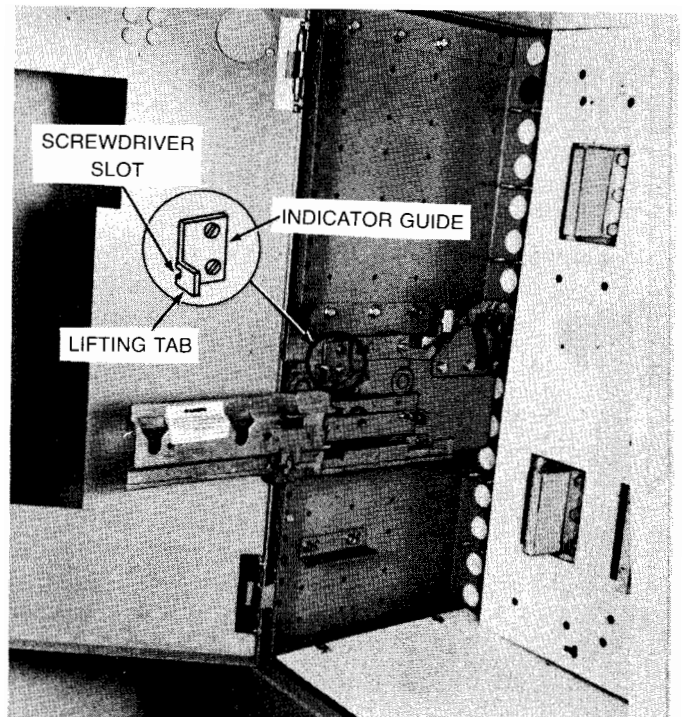

FIGURE 43. RAIL AND CAM ASSEMBLY—LEFT SIDE

PERIODIC MAINTENANCE PROCEDURES

CAUTION! De-energize equipment before performing any work.

POWER-BREAK DRAWOUT ASSEMBLY (600-2500 AMPERES) (cont.)

LUBRICATION

All the areas subjected to mechanical friction have been liberally coated at the factory with a molybdenum disulfide paste for long lasting, wear resistance lubrication.

The primary contact sliding areas have been covered with a special high temperature grease especially formulated to decrease sliding friction and prevent corrosion of the silver surfaces at the high temperatures sometimes encountered at this type of joint.

The secondary contacts have been treated with a corrosion inhibiting grease to reduce the friction encountered as the carriage travels from TEST to ENGAGED position and assures continuity of circuitry at all times.

Figs. 44, 45, 46, 47 and 48 show the areas requiring lubrication and indicate the type as follows:

- (L1) A high temperature grease, GE material D50HD24, designed for use on current carrying joints of circuit breakers. It is white in color and is formulated to improve contact and decrease friction of sliding joints where high pressures and temperatures are to be expected.
- (L2) A pigmented lubricating grease, GE material D50H47, widely used for electrical contacts, and brownish in color, is used on the secondary contact fingers and on the sliding pins and channels of the secondary contact housings.
- (L3) A heavy duty molybdenum disulfide lubricant in paste form—GE material D6Y14A1 or equal should be used for the screw and slide mechanism, crank pins and cam slots where the greatest forces are encountered. For application such as sliding levers, rotating latches and rolls where a paste type lubricant would not penetrate to the friction areas, a molybdenum disulfide solid film lubricant in an aerosol can with plastic extension nozzle should be used to apply the lubricant where desired with a minimum of overspray.

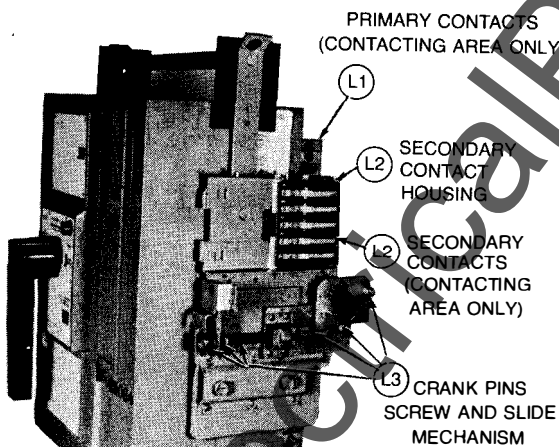

FIGURE 44. CARRIAGE ASSEMBLY—RIGHT SIDE

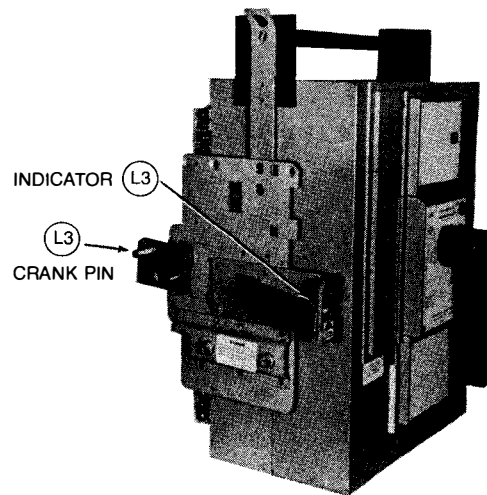

FIGURE 45. CARRIAGE ASSEMBLY—LEFT SIDE

PERIODIC MAINTENANCE PROCEDURES

CAUTION! De-energize equipment before performing any work.

LUBRICATION (cont.)

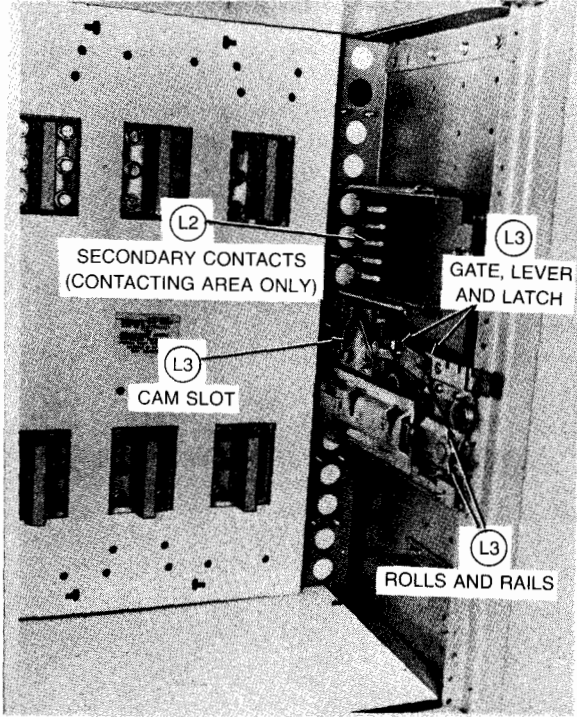

FIGURE 46. RAIL AND CAM ASSEMBLY—RIGHT SIDE

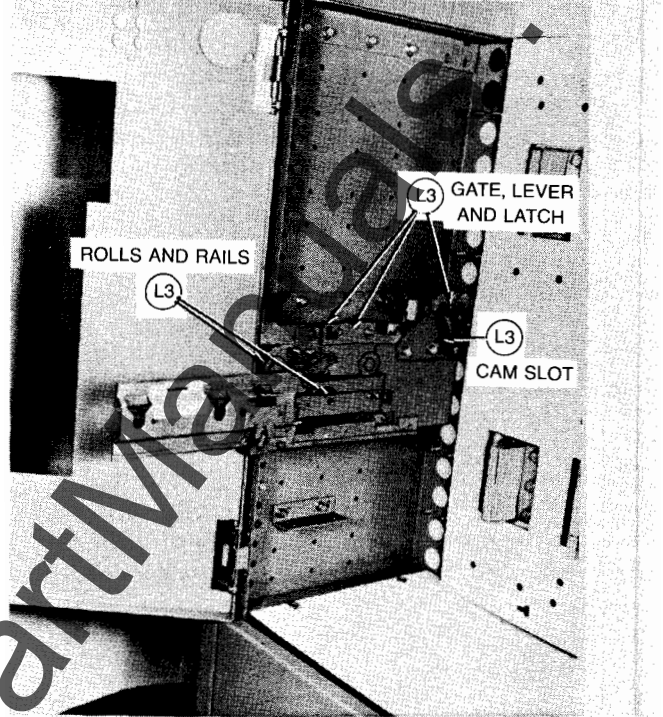

FIGURE 47. RAIL AND CAM ASSEMBLY—LEFT SIDE

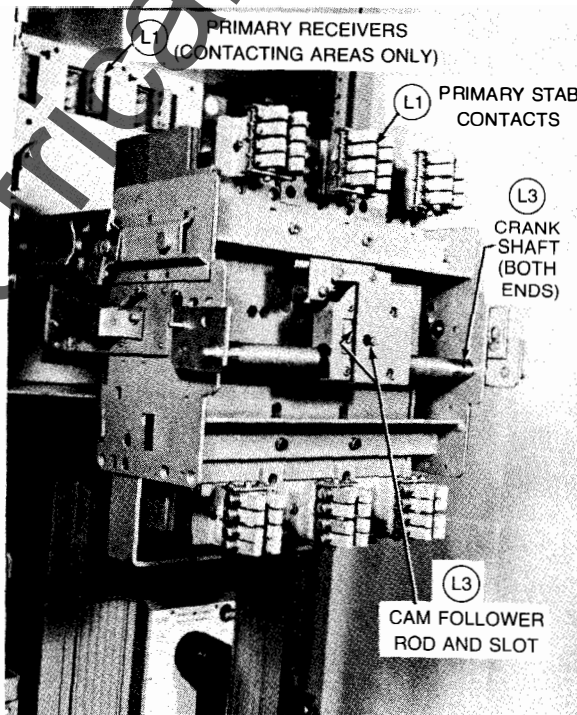

FIGURE 48. CARRIAGE IN TILT-OUT POSITION

PERIODIC MAINTENANCE PROCEDURES

CAUTION! De-energize equipment before performing any work.

SWITCHBOARD MAINTENANCE

A periodic maintenance schedule should be established to obtain the best service from the switchboard. An annual check, and overall maintenance procedure for the switchboard devices and all connections should be followed as a minimum requirement. Equipment subject to highly repetitive operation may require more frequent maintenance.

A permanent record of all maintenance work should be kept. The record should include a list of periodic checks and tests made, the date they were made, the condition of the equipment, and any repairs or adjustments that were performed. Maintenance employees should follow all recognized safety practices, such as those contained in the National Electrical Code, OSHA and in Company or other safety regulations during maintenance.

For specific information regarding the maintenance of devices, such as circuit breakers, relays, meters, etc., refer to the separate instruction book furnished for each device.

1. Periodically inspect the switchboard while under load to determine if there is any indication of overheating. If overheating or any other unsatisfactory condition is found, completely de-energize the switchboard and investigate. Particularly look for loose bolts and connections, or overloading. Remove any accumulation of dirt or other foreign matter in enclosure. Do not touch live parts while switchboard is energized.
2. Plated parts may become dark over a period of time due to oxidation. Do NOT remove this discoloration, as it will reduce the thickness of the plating.
3. Retighten lugs and joints to eliminate possible heating points. Transmittal of vibration through building structure and conduit to switchboard may loosen lugs and joints.
4. Do not open sealed breaker or trip units as calibration may be disturbed. Return to factory for any replacement.

REAR VERTICAL
BUS ISOLATING
BARRIER

REMOVABLE
PLUG BUTTON

REMOVABLE
BOLT CAPS

MAIN BUS
ISOLATING
BARRIERS

REMOVABLE
END COVERS

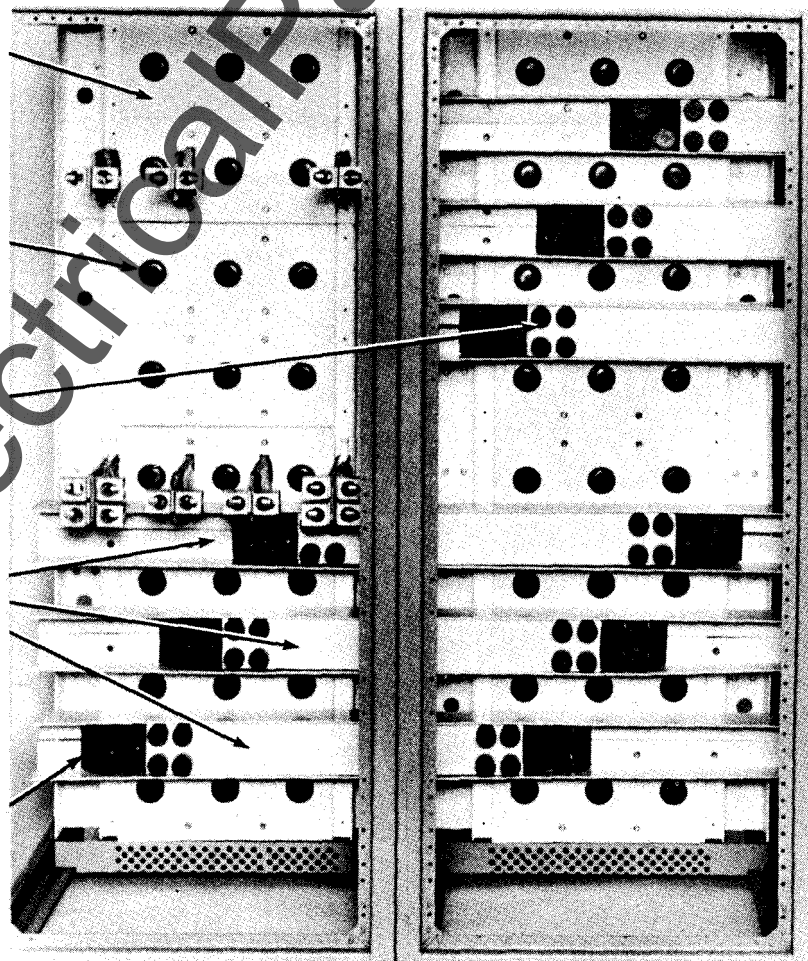

FIGURE 49.

PERIODIC MAINTENANCE PROCEDURES

CAUTION! De-energize equipment before performing any work.

MAINTAINING THE ISOLATED BUS SYSTEM

Main Bus

1. (Fig. 49-50) The main bus is isolated by glass fiber polyester angle barriers around the bus bar, and a flat barrier of the same material fastened to the face of the bus bar with nylon rivets. It is not necessary to remove any of these barriers to remove or install main or splice bus.
2. (Fig. 51) Joint bolts may be maintained without disturbing the isolating barriers. Simply unscrew the red plastic caps over the joint bolts which will expose the bolts for maintenance or removal. These joint bolts terminate in inserts so that there are no loose nuts or washers to contend with.

CONNECTOR
VERTICAL TO
MAIN BUS

ANGLE
BARRIER

FRONT
FLAT
BARRIER

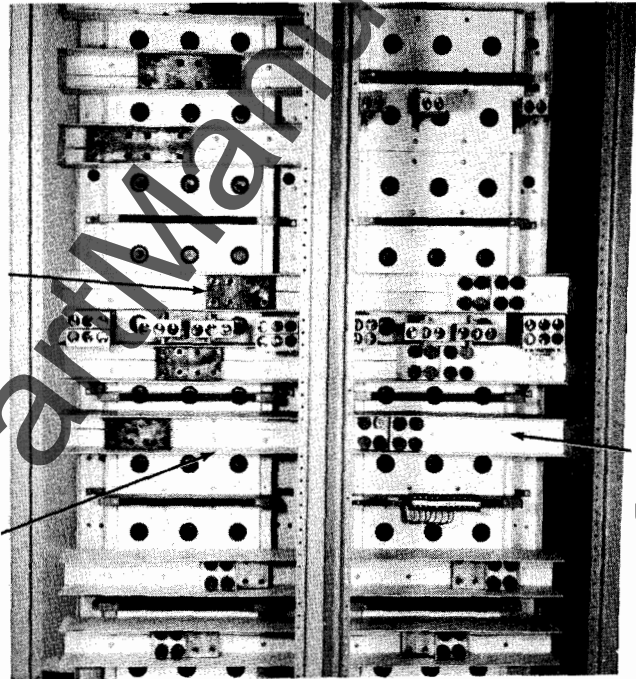

FIGURE 50.

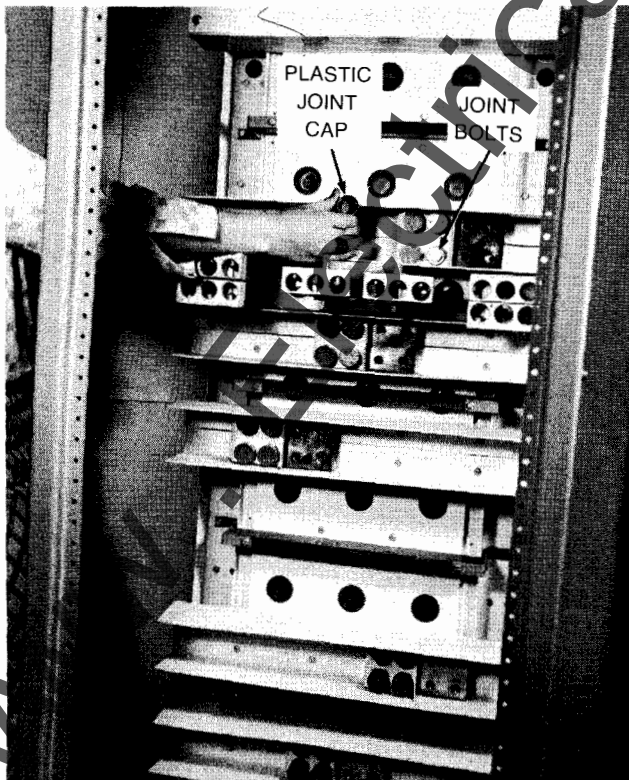

FIGURE 51.

PERIODIC MAINTENANCE PROCEDURES

CAUTION! De-energize equipment before performing any work.

MAINTAINING THE ISOLATED BUS SYSTEM (cont.)

Vertical Bus

1. (Fig. 49-52) Vertical bus is isolated with glass fiber polyester barriers which are fastened to the unit bases with screws.
2. (Fig. 52) To check torque of bolts connecting the line side unit straps to the vertical bus remove the plug buttons over each bolt head. It is not necessary to remove the barriers to check bolt torque.
3. (Fig. 53) Tighten bolts with socket wrench.
4. After bolts are checked be sure to replace plug buttons.
5. The strap connecting the vertical bus to the main bus is located behind the glass fiber polyester barriers. This strap is welded to the vertical bus and maintenance is not required.

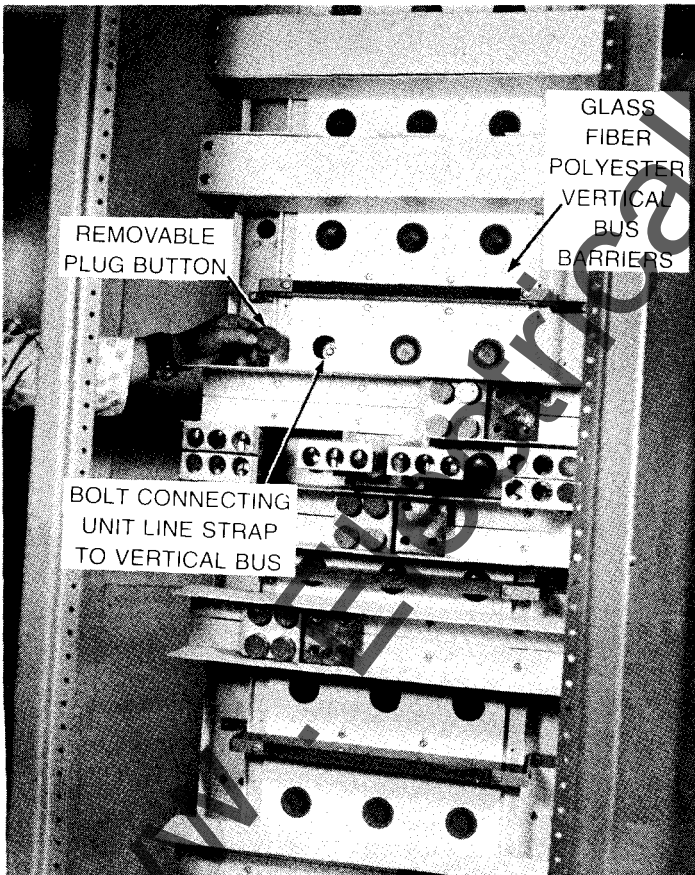

FIGURE 52.

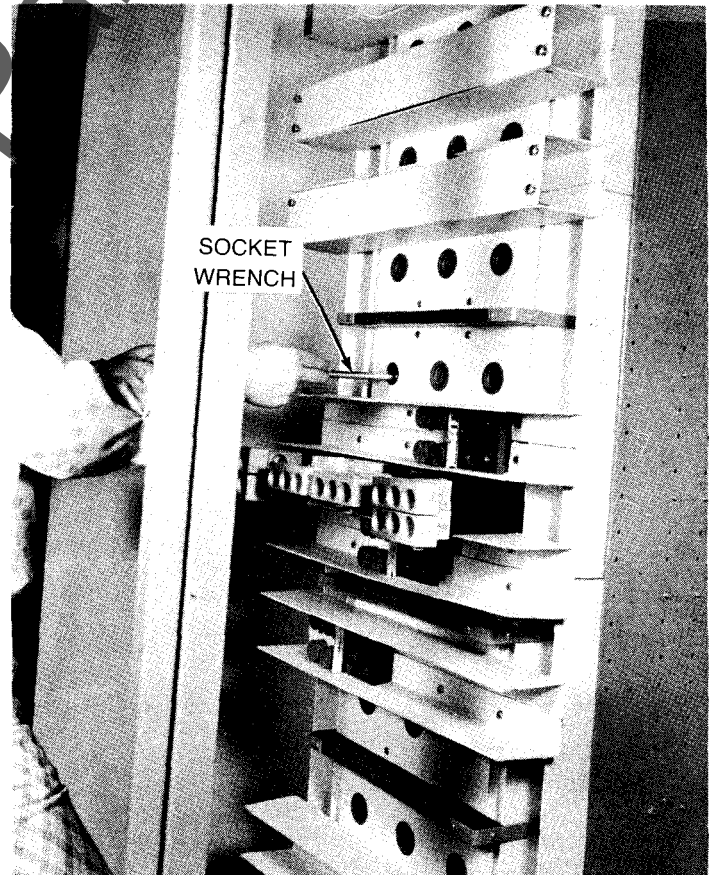

FIGURE 53.

PERIODIC MAINTENANCE PROCEDURES

CAUTION! De-energize equipment before performing any work.

AMBIENT TEMPERATURES AND CIRCUIT LOADING

Switchboards are designed for installation where average ambient temperature will not exceed 40°C (104°F.). For higher temperatures, derating may be required. The conductor temperatures within the enclosure may be as high as 105°C. (220°F.). Some parts of breakers, switches and fuses may run hotter.

SHORT CIRCUITS

Normally, the overcurrent protective device on the circuit will prevent any electrical damage except at the actual point of short-circuit. A thorough inspection of the entire system after any fault current should be made to insure that there has been no mechanical damage to conductors, insulation or equipment.

In addition, the individual overcurrent protective device or devices which performed the short-circuit interruption must be inspected for possible arcing damage to contacts, arc chutes and/or insulation. Do not open sealed devices such as breaker trip units. If there is any possibility that sealed units may have been damaged, they should be replaced. For additional details on the particular device involved, refer to the applicable individual instruction book.

ARCING DAMAGE TO INSULATION

Some organic insulating materials carbonize when subjected to the heat of an electrical arc and lose their in-

ulating qualities. Any insulation found to be carbon tracked must be replaced before applying power.

WATER-SOAKED EQUIPMENT

1. Completely de-energize switchboard.
2. Carefully clean and dry all parts of the switchboard. When using heaters, do not exceed 180 degrees F.
3. Replace all fuses.
4. Individual devices should be inspected for the possible entrance of water, dirt, or foreign matter.
5. Do not open sealed devices such as breaker trip units. Replace them.
6. Prior to re-energizing the switchboard it should be meggered. Refer to testing and inspection procedures.
7. If assistance or guidance is required contact your local General Electric service engineer. General Electric Service Shops have facilities for reconditioning.

SPARE PARTS

A spare parts stock for the components of the Power Break Switchboard, such as bus, insulators, etc. is not recommended. When components need to be reordered, please refer to the nameplate marking, shop drawing number, and order by description. A spare parts stock of devices such as circuit breakers, meters, switches, etc. will vary due to the variety of installations. Your General Electric Sales Engineer will be glad to assist you in the proper selection for a device stock list.

GENERAL  ELECTRIC

DISTRIBUTION ASSEMBLIES DEPARTMENT • GENERAL ELECTRIC COMPANY

PLAINVILLE, CONNECTICUT 06062