

Installation and  
Maintenance Manual



# AKD-8

## Low-voltage Switchgear



# AKD-8 Low-voltage Switchgear

## Table of Contents

### CONTENTS

Description	Page	Description	Page
<b>SECTION I—Introduction</b> .....	4	<b>SECTION IV— (Cont'd)</b>	
1.1 General Information .....	4	C. Foundation Preparation .....	35
1.2 Instruction Book Arrangement .....	4	C-1. Indoor Equipment .....	35
1.3 Related Publications .....	5	C-2. Outdoor Equipment .....	38
<b>SECTION II—Receiving, Handling, and Storage</b> .....	6	4.2 Assembly and Installation of Switchgear Equipment .....	39
2.1 Receiving .....	6	A. General Requirements .....	39
A. Equipment Packages .....	6	B. Detailed Assembly and Installation Instructions .....	39
B. Inspecting for Damage .....	6	B-1. Indoor Equipment .....	39
C. Filing a Claim .....	6	B-2. Outdoor Equipment .....	46
2.2 Handling .....	7	C. Anchoring Switchgear Equipment .....	47
A. Lifting .....	7	C-1. Indoor Equipment .....	48
B. Rollers .....	9	C-2. Outdoor Equipment .....	49
C. Forklifts .....	9	D. Busway Connections .....	49
D. Jacks .....	11	E. Control Wire Connections .....	49
2.3 Storage .....	12	F. Power Cable Connections .....	50
A. Switchgear .....	12	G. Relays and Control Devices .....	50
B. Circuit Breakers .....	12	H. Breaker Hoist .....	51
<b>SECTION III—Description</b> .....	13	H-1. Indoor Equipment .....	51
3.1 General .....	13	H-2. Outdoor Equipment .....	53
3.2 Summary Description .....	13	I. Final Inspection .....	53
3.3 Compartment Area .....	16	<b>SECTION V—Installing and Removing Circuit Breakers</b> .....	54
3.4 Instrument Tray .....	16	5.1 General .....	54
3.5 Breaker Compartment .....	18	A. Inspection and Preparation of Circuit Breakers .....	54
3.6 Circuit Breakers .....	24	B. Circuit Breaker Installation .....	54
A. AKR-6D-30 Breaker .....	24	C. Rejection Feature .....	54
B. AKRU-6D-30 Fused Breaker .....	24	5.2 Installing the AKR Circuit Breakers .....	55
C. AKR-6D-50 .....	25	A. Prior to Installation .....	55
D. AKRU-6D-50 Fused Breaker .....	25	B. Installation Procedures .....	55
E. AKRT-6D-50 Breaker .....	25	5.3 Mounting the AKR-75/100 Circuit Breaker on the Drawout Mechanism .....	58
F. AKR-6D-75 Breaker .....	25	5.4 Removing the AKR-30/50/T50 and AKRU-30/50 Circuit Breakers .....	59
G. AKR-6D-100 Breaker .....	25	5.5 Removing the AKR-75/100 Circuit Breakers .....	59
3.7 Fuse Rollout Elements .....	25	5.6 Installing and Removing AKRU-30/50 Fused Circuit Breakers .....	60
A. AKR-75 Fuse Rollout Carriage .....	25	5.7 Installing Fuses to AKRU-30/50 Circuit Breakers .....	60
B. AKR-100 Fuse Rollout Carriage .....	25	5.8 Installing and Removing Fuse Rollout Elements (FRO)—30-inch Wide Compartments .....	62
3.8 Compartments for Future Breakers .....	26	<b>SECTION VI—Testing and Inspection</b> .....	64
3.9 Auxiliary/Transition Sections .....	26	6.1 General .....	64
3.10 Bus Area .....	28	6.2 Key Interlocks .....	64
A. Busing System .....	29	6.3 Breaker Operation Test .....	64
B. INSUL-BAR Bus Insulation System .....	30	6.4 MicroVersaTrip™ Programmer .....	64
3.11 Feeder Cable and Busway Compartment .....	32	6.5 Final Steps to Be Taken Before Energizing Equipment .....	65
3.12 Ground Bus .....	33		
3.13 AKD-8 Outdoor Switchgear .....	33		
<b>SECTION IV—Equipment Installation</b> .....	35		
4.1 General .....	35		
A. Site Location .....	35		
B. Foundation Requirements .....	35		

# Table of Contents

## CONTENTS

Description	Page
<b>SECTION VII—Operating the Switchgear</b>	66
7.1 Circuit Breaker Operation	66
A. General	66
B. Manually Operated Breakers	66
B-1. Closing Manually Operated AKR Circuit Breakers	66
B-2. Tripping Manually Operated AKR Circuit Breakers	66
C. Electrically Operated Breakers	66
D. Electrical Tripping of AKR Breakers	66
7.2 Circuit Breaker Drawout Operation	66
A. Breaker Positions	66
B. Drawout Operation	67
7.3 Front Doors	67
A. Operation	67
B. Removal and Installation	67
B-1. Door Removal	67
B-2. Door Installation	67
7.4 AKD-8 Switchgear Accessories	68
A. Future Circuit Breaker Compartments	68
B. Circuit Breaker Key Interlock	68
B-1. General	68
B-2. Key Interlock Operation Check	68
C. Rackout Mechanism Padlock Device	68
C-1. General	68
C-2. Padlocking the AKR-30/50/T50 and AKRU-30/50 Breakers	68
C-3. Padlocking the AKR-75/100 Breakers	69
D. Installing and Removing Metering CT's	69
E. Removing Shutter Units	69
E-1. Removing an AKR-30/50 or AKRU-30/50 Shutter Unit	70
E-2. Removing an AKR-75/100 or Fuse Rollout Shutter Unit	71
F. Installing a Shutter Unit	72
F-1. Installing an AKR-30/50 or AKRU-30/50 Shutter Unit	72
F-2. Installing an AKR-75/100 Fuse Rollout Shutter Unit	73
<b>SECTION VIII—Energizing the Switchgear</b>	73
8.1 Before Energizing	73
8.2 Energizing	73
A. Energizing Procedures	73

Description	Page
<b>SECTION IX—Maintaining the Switchgear</b>	74
9.1 Maintenance Requirements	74
A. General	74
9.2 Breaker and Instrument Compartments	74
A. Breakers	74
A-1. Test for Proper Operation	74
A-2. Checks after Breaker is De-energized	74
A-3. Lubrication	75
B. Instruments, Instrument Transformers, and Relays	75
C. Breaker Compartment Interiors	75
9.3 Bus Area	75
9.4 Cable and Busway Compartment	75
9.5 Over-all Switchgear	76
9.6 Paint Refinishing	76
9.7 Circuit Breaker Lifting Mechanism	76

## APPENDICES

Description	Page
A. Torque Values	77
B. Circuit Breaker Rejection Features	77
C. Circuit Breaker Ratings	81
D. Circuit Breaker Accessory Device Ratings	82
E. Circuit Breaker Weights	84
F. Circuit Breaker Repetitive Duty Data	84
G. Fuses for AKRU-30/50 and FRO Elements	85

These instructions do not purport to cover all details or variations in equipment nor to provide for every possible contingency to be met in connection with installation, operation or maintenance. Should further information be desired or should particular problems arise which are not covered sufficiently for the Purchaser's purposes, the matter should be referred to the General Electric Company. These instructions are intended for use by qualified personnel only.

# AKD-8 Low-voltage Switchgear

## SECTION I—Introduction

### 1.1—General Information

This manual contains procedures for receiving, handling, storage, equipment installation, operation, and maintenance and service of AKD-8 Low-voltage Switchgear, manufactured by General Electric Company, Distribution Equipment Division, 41 Woodford Avenue, Plainville, Connecticut 06062, U.S.A.

**NOTE:** The personnel responsible for installing, operating, and servicing this equipment should be thoroughly familiar with the contents of this manual.

Before any installation work is performed, thoroughly read and understand the material in this instruction manual and the drawings furnished with the equipment. The documentation shipped with the equipment includes the Summary, Front View, Elementary Diagram, and Instruction Book. This material is located in a forward compartment tagged "INSTRUCTIONS IN THIS COMPARTMENT." The documentation provides all of the information necessary for installation of the switchgear. When requesting information from the General Electric Company, include the complete data appearing on the equipment nameplate, requisition number, summary number, and elementary diagram number. The nameplate is located inside one of the following four locations:

1. the left-hand auxiliary/transition compartment (if included with the equipment),
2. the right-hand auxiliary/transition compartment (if a left-hand auxiliary/transition compartment is not included),
3. the left-hand main breaker compartment (if no auxiliary/transition compartment is included), or
4. the right-hand main breaker compartment (if the equipment is supplied without a main breaker compartment located on the left-hand end of the equipment).

When requesting information concerning any specific item furnished with the switchgear, refer to that item by description, part number, its location within this manual, and any applicable drawing number. Any material external to the equipment, which may be required to meet local codes (such as mats, screens, railings, etc.), is not furnished by the General Electric Company.

If there are any questions or requirements not covered in this manual or in the accompanying drawings, please contact the local sales office of the General Electric Company.

### 1.2—Instruction Book Arrangement

Information and procedures in this instruction book are divided into sections as follows:

- SECTION I, INTRODUCTION, gives a brief account of the equipment's function and provides for general information, and applicable data for the equipment and its components.
- SECTION II, RECEIVING, HANDLING AND STORAGE, describes procedures required for receiving and handling the equipment and how to prepare it for short- or long-term storage.
- SECTION III, DESCRIPTION, describes the AKD-8 Low-voltage Switchgear and its various components. Included are the section enclosure, breaker compartment, circuit breakers, instrument panels and instrument trays, bus bar arrangement, incoming cable and busway, ground and neutral bus, outdoor equipment, and auxiliary section. This section also explains how the electrical and mechanical components perform their assigned functions.
- SECTION IV, EQUIPMENT INSTALLATION, provides the information needed prior to installation, site location and foundation requirements, and how to anchor the equipment properly and safely. It also covers installation of peripheral equipment and includes information on electrical connections and mechanical construction.
- SECTION V, INSTALLING AND REMOVING CIRCUIT BREAKERS, gives a step-by-step procedure for lifting the breaker from the floor, installing it on rackout rails, and moving it into the connected position. A further procedure is given to withdraw a breaker, remove it from the rackout rails, and lower it to the floor. Also included is a description of the rejection system provided to avoid the inadvertent use of an incorrect breaker in a breaker compartment.
- SECTION VI, TESTING AND INSPECTION, reviews items which should be tested or inspected prior to energizing and operating the switchgear.
- SECTION VII, OPERATING THE SWITCHGEAR, covers how to operate the breakers, and contains information concerning draw-out provisions, doors, and various accessories.
- SECTION VIII, ENERGIZING THE SWITCHGEAR, outlines the steps to be taken before and during the electrical energization of the equipment.

## SECTION I—Introduction

- SECTION IX, MAINTAINING THE SWITCHGEAR, provides instructions for all preventive maintenance, servicing, and lubrication information for the switchgear equipment. Included is service and maintenance data for the circuit breakers, instrument compartments, instruments, bus bar joints, and cable and busway connections. This section also includes paint refinishing requirements.
- APPENDICES A through G contain information concerning screw and bolt torque values, circuit breaker ratings, rejection features, accessory device ratings, repetitive duty data, and fuse data.

### 1.3—Related Publications

Addendums to this instruction book are the available service and maintenance publications supplied separately for circuit breakers, relays and other devices not described in this instruction book.

In addition to instruction books, the following drawings will be supplied as required for each order of AKD-8 switchgear equipment:

1. General arrangement drawings, including front view and floor plan.
2. Elementary and connection drawings (or wiring routing tables) which indicate and identify test and connection points including terminal blocks, device studs, switch contact developments, and remote connections.
3. Summary of switchgear equipment which is a list of all the components furnished with the switchgear, including the breakers, identified by catalog number.

These are all the documents necessary to install, operate, and maintain the equipment. One complete set of drawings and instruction books is shipped with the equipment.

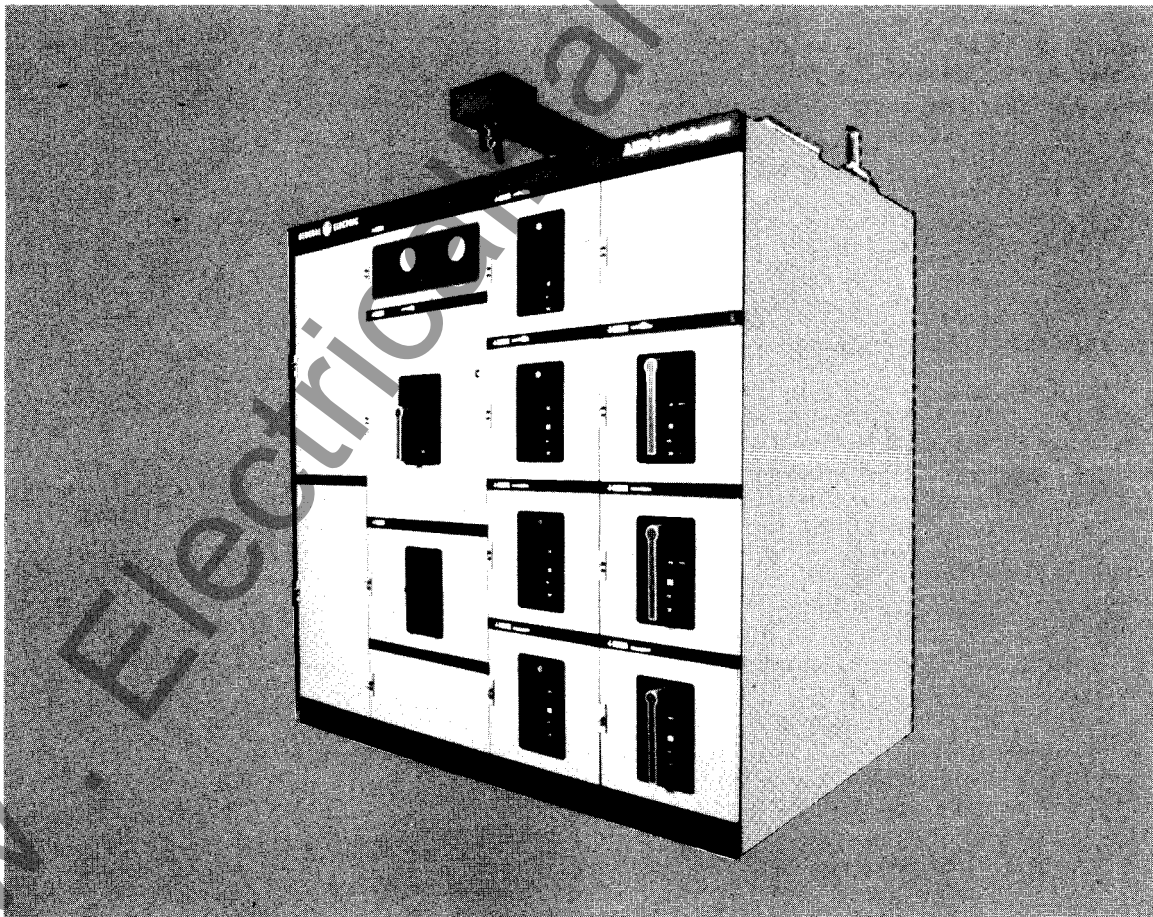

Fig. 1-1. General Electric AKD-8 Low-voltage Switchgear

# AKD-8 Low-voltage Switchgear

## SECTION II—Receiving, Handling, and Storage

### 2.1—Receiving

#### A. Equipment Packages

Every package leaving the factory is plainly marked with the case number, requisition number, and customer's order number. If the equipment has been split for shipment, the section numbers of the equipment enclosed in each shipping package are identified.

**NOTE:** To avoid the loss of any parts when unpacking, the contents of each container should be carefully checked against the packing list before discarding the packing material.

The contents of each shipping package are listed on the Master Packing List. In addition, this list includes the number of the shipping crate in which miscellaneous parts needed to install and operate the equipment (such as hardware, contact lubricant, touch-up paint, breaker closing devices, etc.) are located. Normally, such devices are packed in a cardboard carton and the carton secured in an empty switchgear compartment. See Fig. 2-1. If such items are packed in a switchgear section instead of a separate crate, the list will indicate the appropriate section number in which they are stored. Large items (such as hoist dollies and hoist carriages used with indoor equipment) will always be shipped in separate crates or cartons. See Fig. 2-2.

#### B. Inspecting for Damage

All equipment leaving the factory is carefully inspected and packed by personnel experienced in the proper handling and packing of electrical equipment. Upon receipt of any equipment, immediately perform a visual inspection to ascertain if any damage has been sustained in shipping or if there are any loose parts.

All circuit breakers are shipped separately in individual containers with the breaker in the open position. Circuit breakers should be unpacked and visually inspected for damage or loose parts as soon as possible after they have been received.

Be sure to inspect all devices mounted or packed inside compartments of each section to see if any have been dislodged or damaged.

#### C. Filing a Claim

If any damage is evident, or indication of rough handling is visible, file a claim for damage at once with the transportation company and notify the nearest General Electric Company Sales Office immediately. Information on damaged parts, part number, case number, requisition number, etc., should accompany the claim.

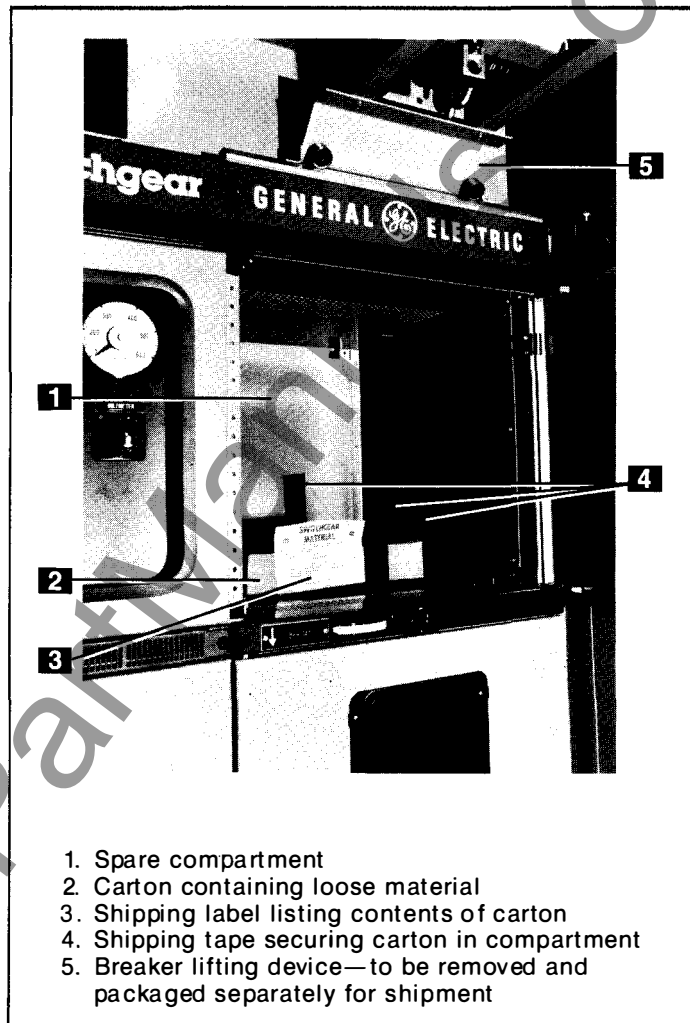

Fig. 2-1. Packaging of loose material for shipment

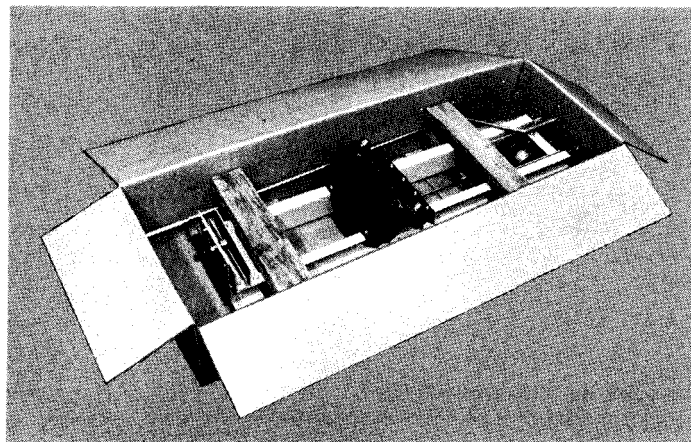

Fig. 2-2. Carton containing breaker lifting device

# SECTION II—Receiving, Handling, and Storage

## 2.2—Handling

**NOTE:** It is preferable to leave the shipping skids in place under the switchgear until it reaches its final location. The equipment should be installed in its final location prior to installing the circuit breakers.

### A. Lifting

The switchgear sections are best handled by lifting with a crane as shown in Fig. 2-3. Removable lifting plates are provided, as standard equipment, on the top of each switchgear section. To preserve the external appearance of the equipment, it is suggested that the lifting plates be left in place except where adjacent equipments must be bolted together, i.e. shipping splits, etc.

Utilize four equal length cables and an overhead crane, each with a minimum load rating of twice the weight of the switchgear.

**Example:** Switchgear Section Weight = 5,000 pound. The crane and the four lift cables must have a minimum load lifting capacity of 10,000 pounds.

**NOTE:** The angle between the cables and the top of the equipment must be at least 45 degrees. If this is not possible because of lack of headspace, spreader bars must be used. Also, lift cables with greater load capability may be necessary, depending upon the angle between the cables and the crane hook.

Connect a cable from the crane to the four lifting plates located on the top-front and rear of the switchgear (Fig. 2-3).

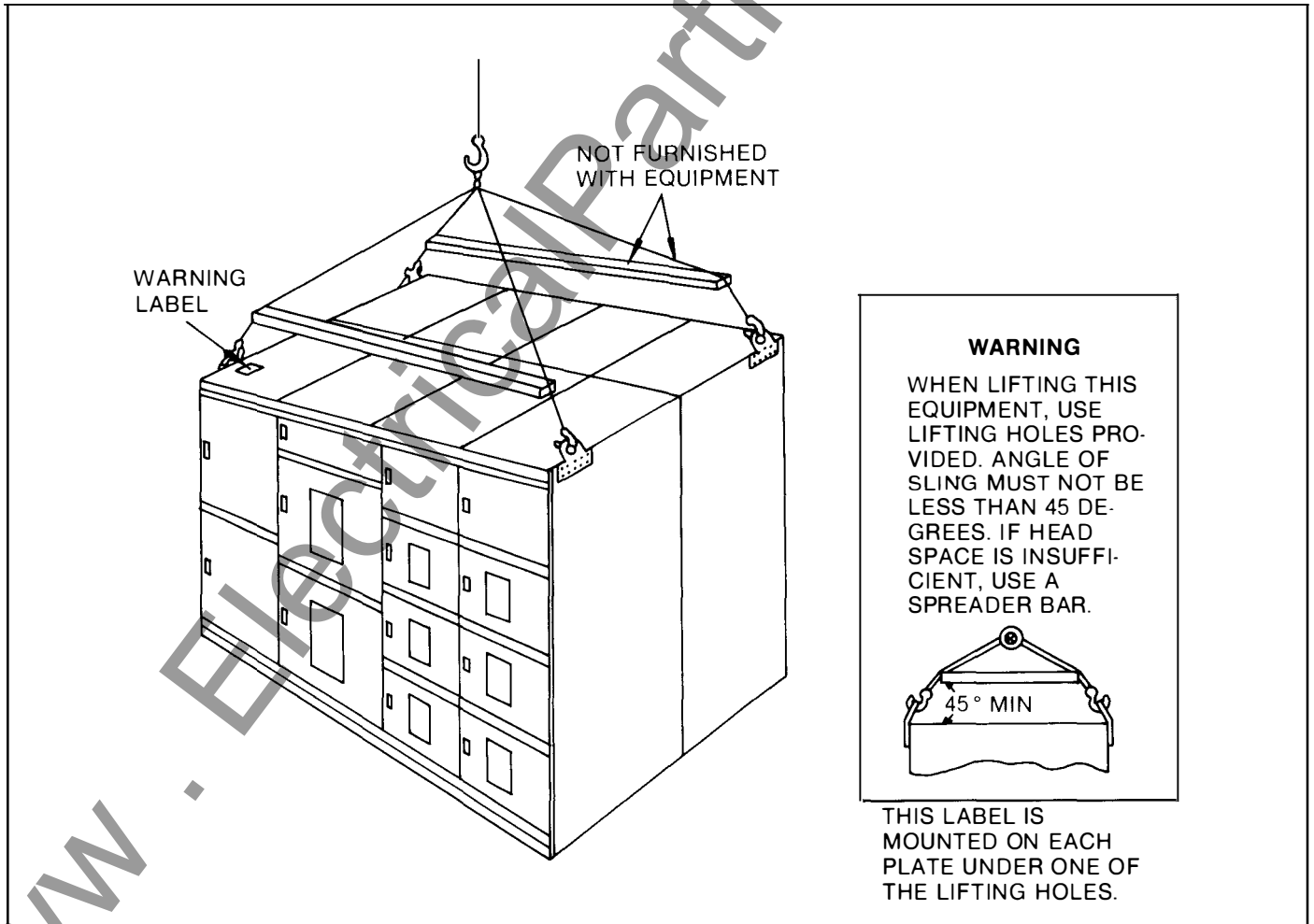

Fig. 2-3. Recommended method of lifting AKD-8 enclosure

# AKD-8 Low-voltage Switchgear

## SECTION II—Receiving, Handling, and Storage

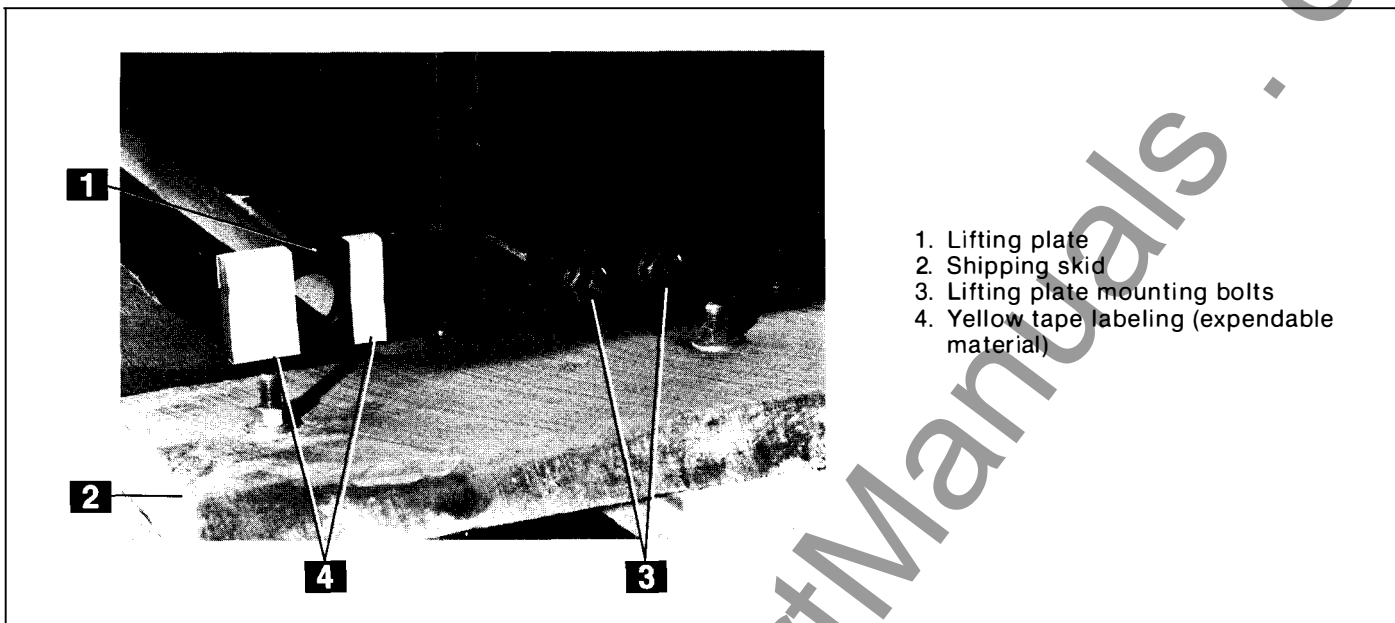

Fig. 2-4. Location of lifting plates AKD-8 outdoor enclosure

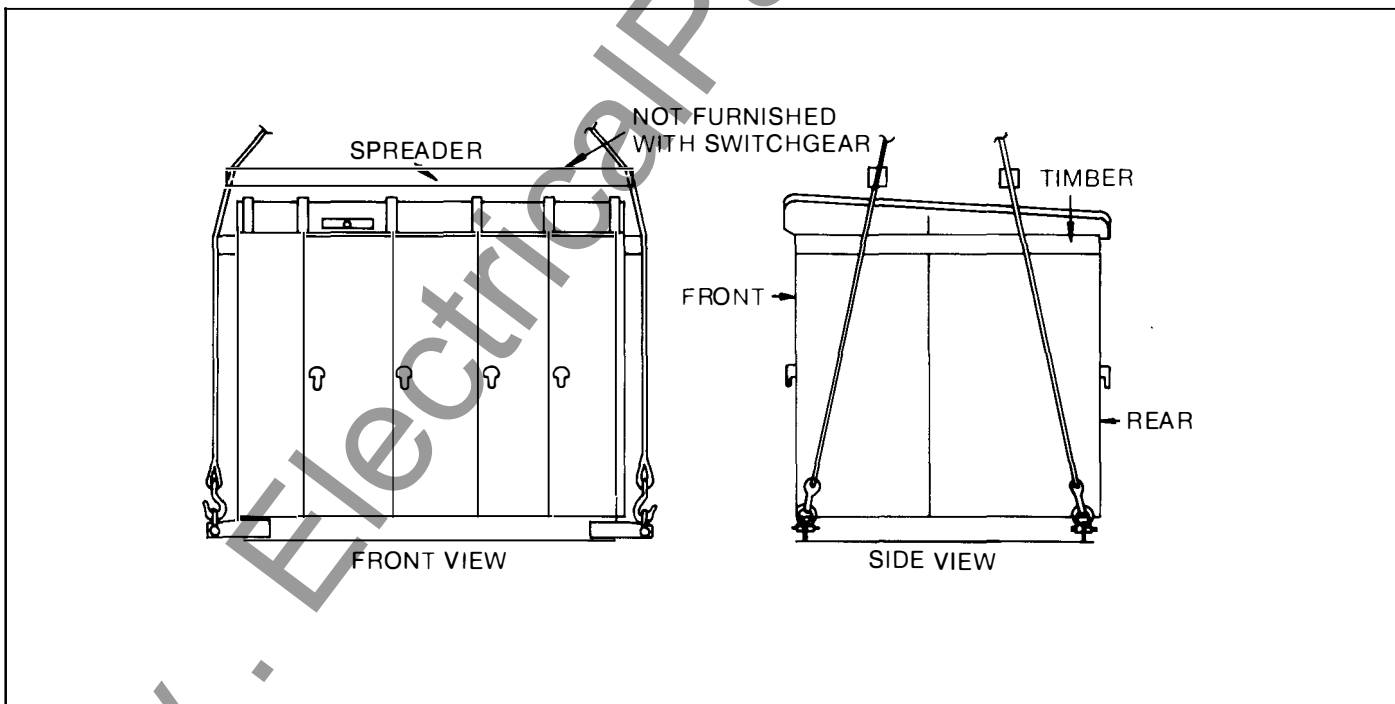

Fig. 2-5. Recommended method of lifting AKD-8 outdoor enclosure by crane using cable spreader

## SECTION II—Receiving, Handling, and Storage

Take up the slack in the lifting device very carefully and manually stabilize the switchgear to prevent it from rotating.

**WARNING:** DO NOT STAND UNDER SWITCHGEAR WHILE IT IS BEING MOVED. SERIOUS INJURY MAY OCCUR IF THE CABLES OR LIFTING DEVICE FAIL.

**CAUTION:** GENTLY LOWER THE SWITCHGEAR SECTION ONTO THE LEVEL SITE LOCATION. IF THE SWITCHGEAR IS ROUGHLY HANDLED OR JARRED, IT IS POSSIBLE TO DAMAGE OR MISALIGN INTERNAL COMPONENTS.

Methods of lifting outdoor switchgear sections are much the same as for indoor equipment except the lifting plates are provided at the base of the structure. See Fig. 2-4.

If lifting outdoor switchgear sections, side support timbers must be placed along the sides to prevent any damage that could be caused by the lifting cables. In addition, a spreader bar must be inserted between each lift cable, both front and rear, above the switchgear equipment as shown in Fig. 2-5. Proceed to lift and place the outdoor switchgear utilizing all the precautions and requirements that apply to lifting the indoor switchgear.

The lifting plates, Fig. 2-4, should be removed after the equipment is permanently anchored so passageways at the ends of the equipment will not be obstructed.

### B. Rollers

If crane facilities are not available, the equipment may be moved into position by means of construction rollers placed under the shipping skids. The switchgear may be raised enough for the placement of rollers by means of a fork lift or jack.

There should never be less than four rollers under the equipment unless the line-up is less than five feet long. Use one roller for each 18 inches of equipment length.

### C. Forklifts

When using a forklift to raise the line-up to position rollers underneath, proceed as follows:

1. Expand forklift tines to their maximum (widest) extension.
2. Carefully insert tines of forklift below one side of the switchgear line-up at the approximate center of the panel as shown in Fig. 2-6.

**NOTE:** Do not attempt to lift or move the equipment with a forklift positioned in the front or rear of the equipment.

3. Position one man in the front and one man in the rear of the switchgear to stabilize the equipment as it is being raised.
4. Position one roller under the skids close to the raised end of the line-up.
5. Carefully lower the gear until it rests on the roller as shown in Fig. 2-7.
6. Repeat the lifting process at the other end and place the appropriate number of rollers under the skids spacing them evenly across the width of the line-up.

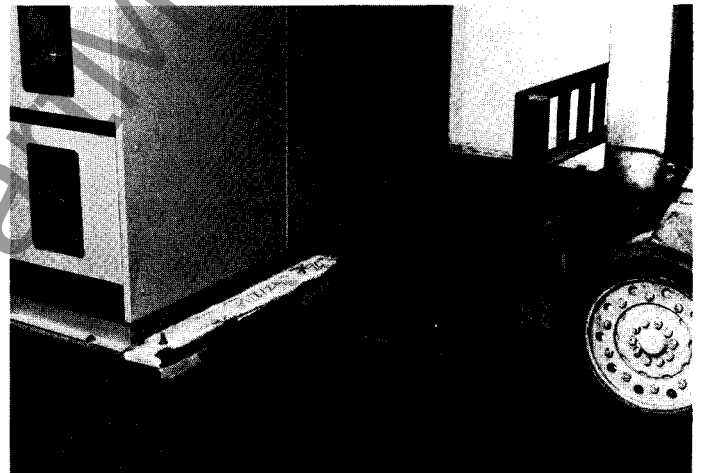

Fig. 2-6. Placing forklift tines under AKD-8 equipment shipping skid

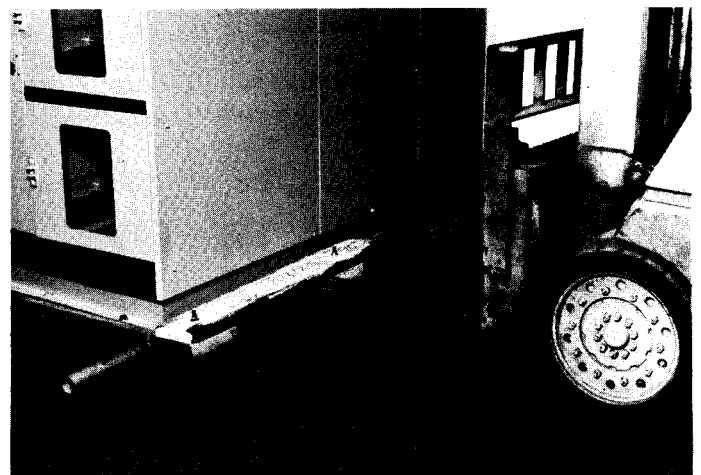

Fig. 2-7. Placement of rollers under shipping skid

# AKD-8 Low-voltage Switchgear

## SECTION II—Receiving, Handling, and Storage

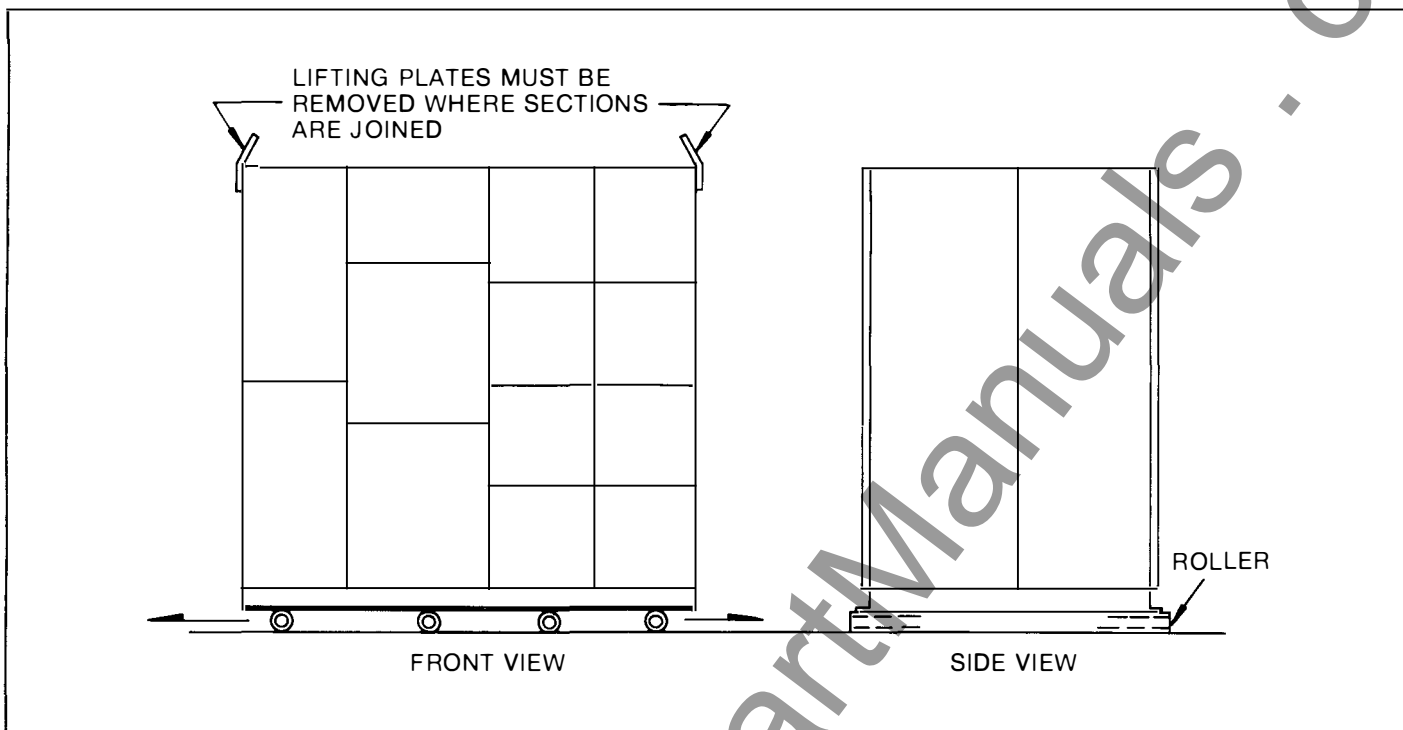

Fig. 2-8. Method of rolling equipment into place

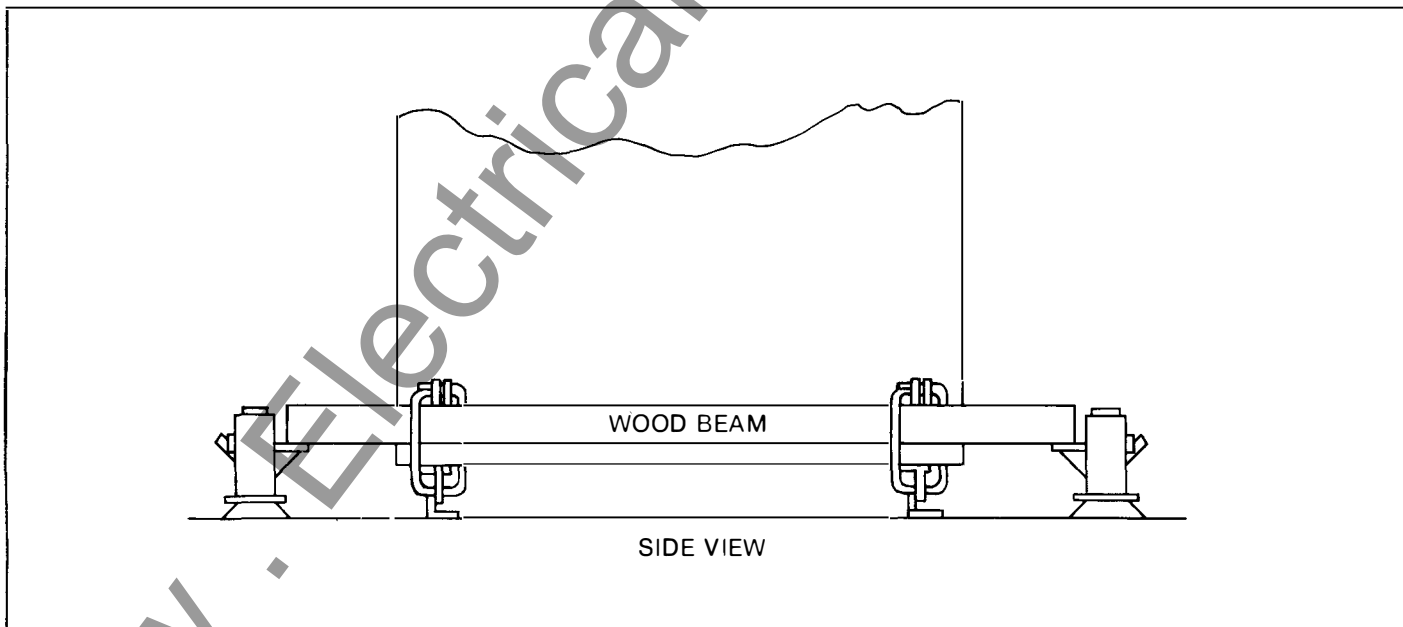

Fig. 2-9. Recommended method of jacking AKD-8 outdoor equipments

## SECTION II—Receiving, Handling, and Storage

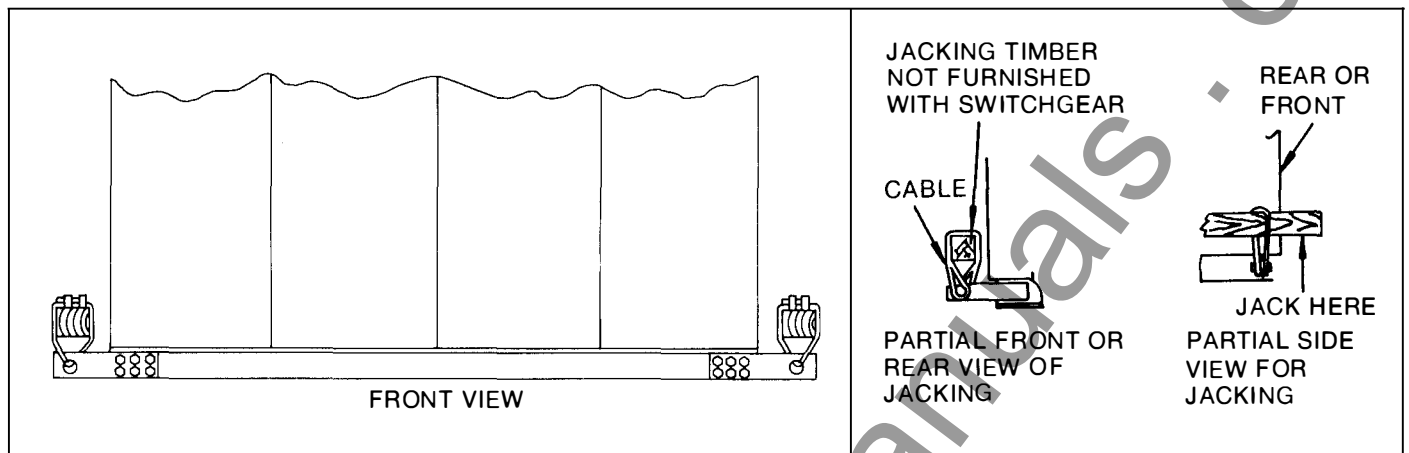

Fig. 2-10. Recommended method of jacking AKD-8 outdoor enclosure

- Carefully lower the gear until it rests on the rollers (Fig. 2-7).

**NOTE:** If shipping skids are removed prior to final placement of equipment, rollers may only be used to move the equipment in a direction parallel to the front.

- While carefully pushing the switchgear to its final site position, the rollers that are freed from the rear of the switchgear are then repositioned at the forward end. This procedure should be continued until the switchgear is in its final location. See Fig. 2-8.

- When the switchgear is in its final position, remove all lug bolts holding the shipping skids to the switchgear line-up.

- Insert the tines of the forklift at one end of the line-up, raise slightly, and remove the loose rollers.

- Lower the end of the gear carefully to the floor.

- Raise the other end of the line-up slightly and remove the remaining roller at that end.

### D. Jacks

Jacks may be used in place of forklifts to raise and lower switchgear.

- Place a jack under the front and rear corners of one end of the line-up. Figures 2-9 and 2-10 illustrate the use of jacks with outdoor equipment.

**CAUTION:** DO NOT PLACE JACKS IN ANY OTHER LOCATION OTHER THAN THE FRONT AND REAR CORNERS OF THE SWITCHGEAR. DOING SO MAY RESULT IN SERIOUS DAMAGE TO THE SWITCHGEAR EQUIPMENT.

- Raise the switchgear evenly and just enough to position a roller beneath the equipment. Gently lower the switchgear onto the roller. Repeat the procedure at the opposite end of the switchgear, raising the gear far enough to place the appropriate number of rollers under the skids, spacing them evenly across the width of the line-up. Gently lower the gear onto the rollers.

- While carefully pushing the switchgear to its final site position, the rollers that are freed from the rear of the switchgear are then repositioned at the forward end. This procedure should be continued until the switchgear is in its final location.

- When the switchgear is in its final position, remove all lug bolts holding the shipping skids to the switchgear line-up.

- Place one jack at each corner, front and rear, of the switchgear. Carefully raise the line-up evenly and remove the rollers and the shipping skids. Evenly lower the line-up to the floor and remove the jacks.

# AKD-8 Low-voltage Switchgear

## SECTION II—Receiving, Handling, and Storage

### 2.3—Storage

#### A. Switchgear

If it is necessary to store the switchgear equipment for any length of time, the following precautions should be taken to prevent corrosion or deterioration.

1. Remove protective covering. Check thoroughly for damage.
2. Store in a clean, dry, rodent-free location with moderate temperature and provide protective coverings to prevent dirt, water, or other foreign substances from entering the switchgear.

**CAUTION:** REMOVE ALL CARTONS, CONTAINERS AND ANY OTHER MISCELLANEOUS PACKAGING AND PACKING MATERIAL FROM INSIDE THE SWITCHGEAR SECTIONS BEFORE ENERGIZING ANY INTERNAL HEATERS. TO PREVENT FIRE, REMOVE ANY PLASTIC OR POLYETHYLENE SHROUDING FROM THE SWITCHGEAR SECTIONS BEFORE ENERGIZING ANY INTERNAL HEATERS.

3. If dampness or condensation may be encountered in the storage location, heaters must be placed inside the switchgear sections to prevent moisture damage. Approximately 250 watts of heat in each section is required. Incandescent lamps may be used for this purpose. These lamps should be located in the bottom breaker compartment of

each section and supported so the bulb will not touch adjacent materials. On outdoor switchgear equipment, this may be accomplished by making a temporary power supply connection to the heaters already installed in the equipment.

**CAUTION:** IF THE SPACE HEATERS ARE TO BE TEMPORARILY ENERGIZED FROM EXTERNAL SOURCE, IT IS IMPORTANT TO REMOVE THE FUSES ON THE SECONDARY SIDE OF THE CONTROL POWER TRANSFORMER. THIS PRECAUTION IS TO PREVENT A FEEDBACK OF HIGHER VOLTAGE TO OTHER PORTIONS OF THE EQUIPMENT THROUGH THE CPT PRIMARY.

#### B. Circuit Breakers

If circuit breakers are not to be placed into service at once, remove them from their shipping cartons and thoroughly inspect them for damage. If the breakers are in satisfactory condition, replace the breakers in their shipping cartons for storage. Do not remove the circuit breaker shipping members at this time.

Store the circuit breakers in a clean, dry location in an upright position. They must be properly supported to prevent bending of the studs or damage to any of the breaker parts. Do not remove any protective grease until the circuit breakers are ready to be installed. A plastic or canvas-type cover should be provided to reduce the possibility of damage to the breakers due to dust and water.

## SECTION III—Description

### 3.1—General

This section contains a description of the General Electric AKD-8 Low-voltage Switchgear. It also describes the functions of the electrical and mechanical systems.

Figure 3-1 shows the installation of a typical single-ended load center unit substation.

### 3.2—Summary Description

General Electric AKD-8 Low-voltage Switchgear is a free-standing assembly of metal-enclosed sections containing low-voltage power circuit breakers, bus bars, cable termination provisions, auxiliary power circuit protective devices, controls, and instrumentation. It may also be an integral part of a load center unit substation, either single-ended or double-ended.



Fig. 3-1. Installation of a typical AKD-8 Load Center Unit Substation

# AKD-8 Low-voltage Switchgear

## SECTION III—Description

Figure 3-2 is a side view of a typical section showing compartmentation. Figure 3-3 is an outline of a typical

single-ended load center unit substation illustrating the nomenclature used for all equipment.

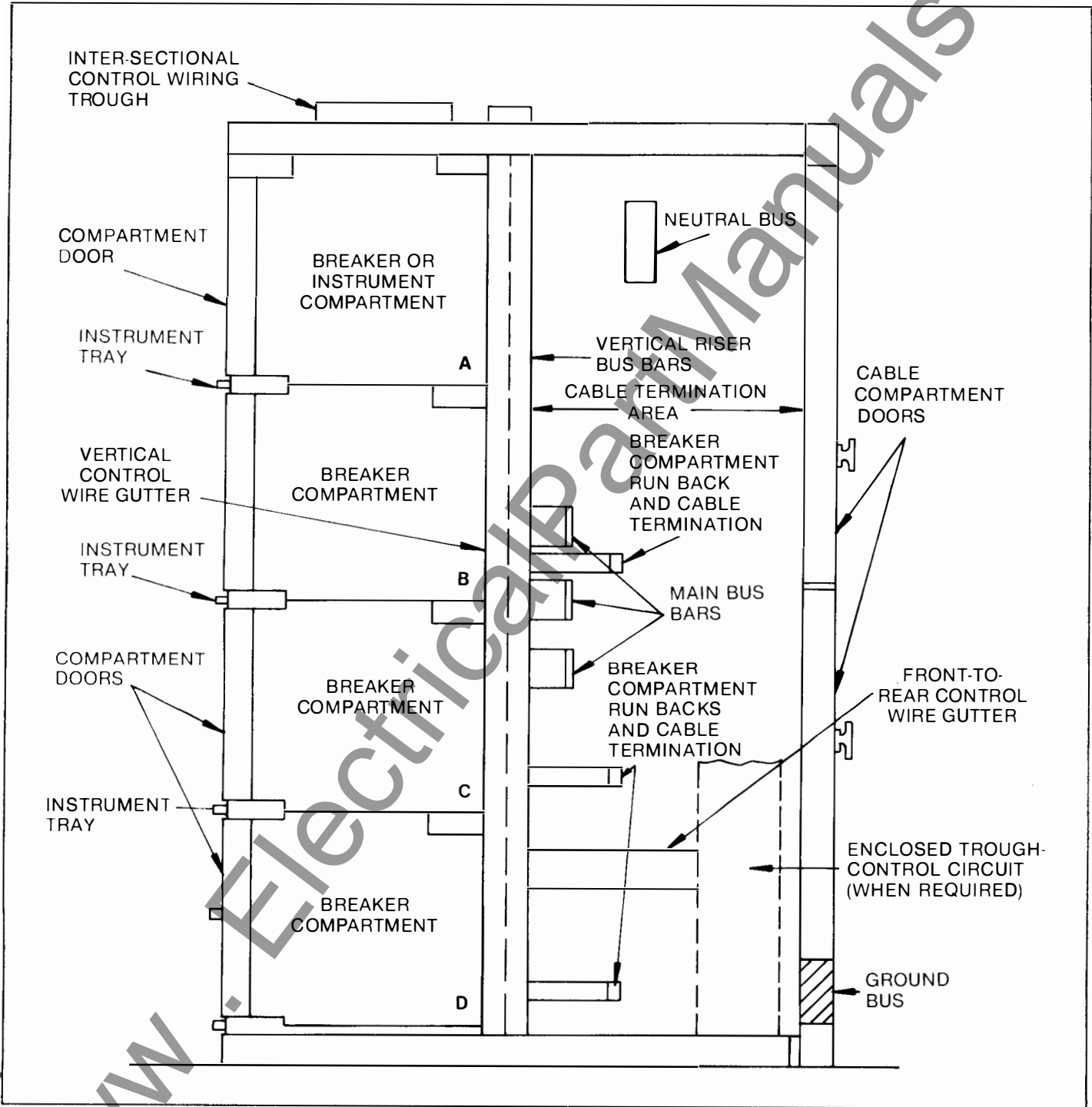

Fig. 3-2. Side-view section of AKD-8 switchgear

## SECTION III—Description

All of the primary circuit switching and protective devices, secondary control and metering devices, control fuses, and instrument transformers are mounted in the enclosure. The breaker compartments include drawout rails, stationary breaker contacts, interlocks, and necessary control and indi-

cating devices. The breakers are provided with self-aligning primary and secondary disconnecting contacts, breaker locking mechanism, and integral trip programmer. The individual sections, compartments, and devices are described in the following paragraphs.

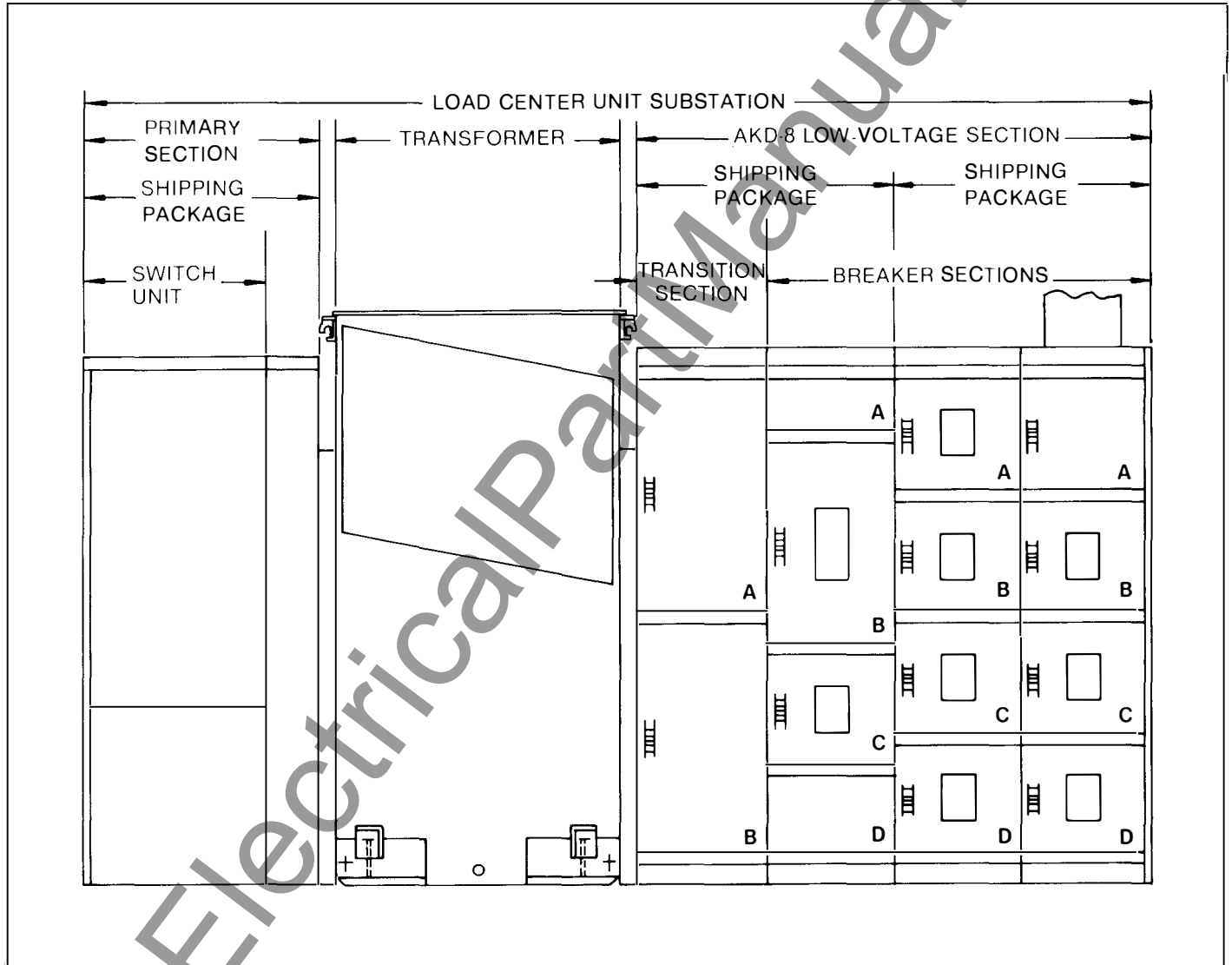

Fig. 3-3. Outline of typical AKD-8 Load Center Unit Substation

# AKD-8 Low-voltage Switchgear

## SECTION III—Description

### 3.3—Compartment Area

The front enclosure of each section is divided into individual compartments. These compartments house either a low-voltage power circuit breaker or are used to mount instruments, control components and other ancillary devices.

**WARNING:** WITH THE STANDARD SLIDE-OUT INSTRUMENTATION TRAY IN THE OPEN POSITION, LIVE TERMINALS ARE EXPOSED. TOUCHING THESE TERMINALS MAY RESULT IN ELECTRICAL SHOCK OR BURN.

### 3.4—Instrument Tray

A standard slide-out instrumentation tray, Fig. 3-4, is located above each breaker compartment eliminating cross-hinge wiring. When required, optional feeder instrumentation may be included and mounted on the front face of the tray such as a horizontal-edgewise ammeter, ammeter switch, pilot lights or annunciator, and test switches.

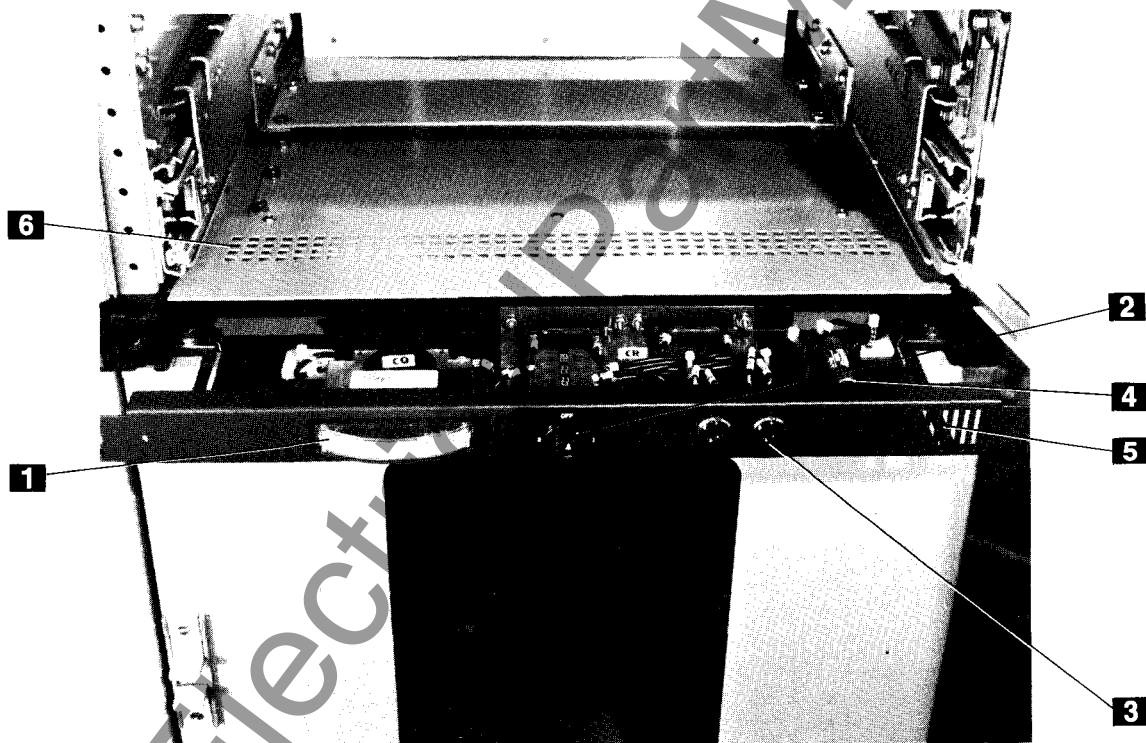

1. Ammeter
2. Ammeter switch
3. Pilot lights
4. Control circuit fuse
5. Grille
6. Ventilation openings in stationary cover

Fig. 3-4. Slide-out instrument tray

## SECTION III—Description

Fuses for the close and trip circuits of the electrically operated breakers are mounted inside the tray and are fully accessible when the tray is pulled out. Routine wiring inspections and fuse checks or fuse replacements can be performed with the breaker compartment door in the closed position so that operators are protected from the energized primary circuits.

The instrument tray also permits the flow of ventilating air to the breaker compartment. The grille, (5), Fig. 3-4, on the tray face with the openings (6) in the stationary cover provide an indirect path for the entrance of cooling air.

An instrument compartment with a recessed swinging instrument panel, Fig. 3-5, is available as a standard feature. These panels can be used to mount meters and/or instruments and other devices associated with the incoming supply circuit. Switches used in various control circuits may also be installed on these panels.

Relays, fuse cutouts and similar devices may be installed in the compartment behind the swing-out instrument panel or in adjacent compartments.

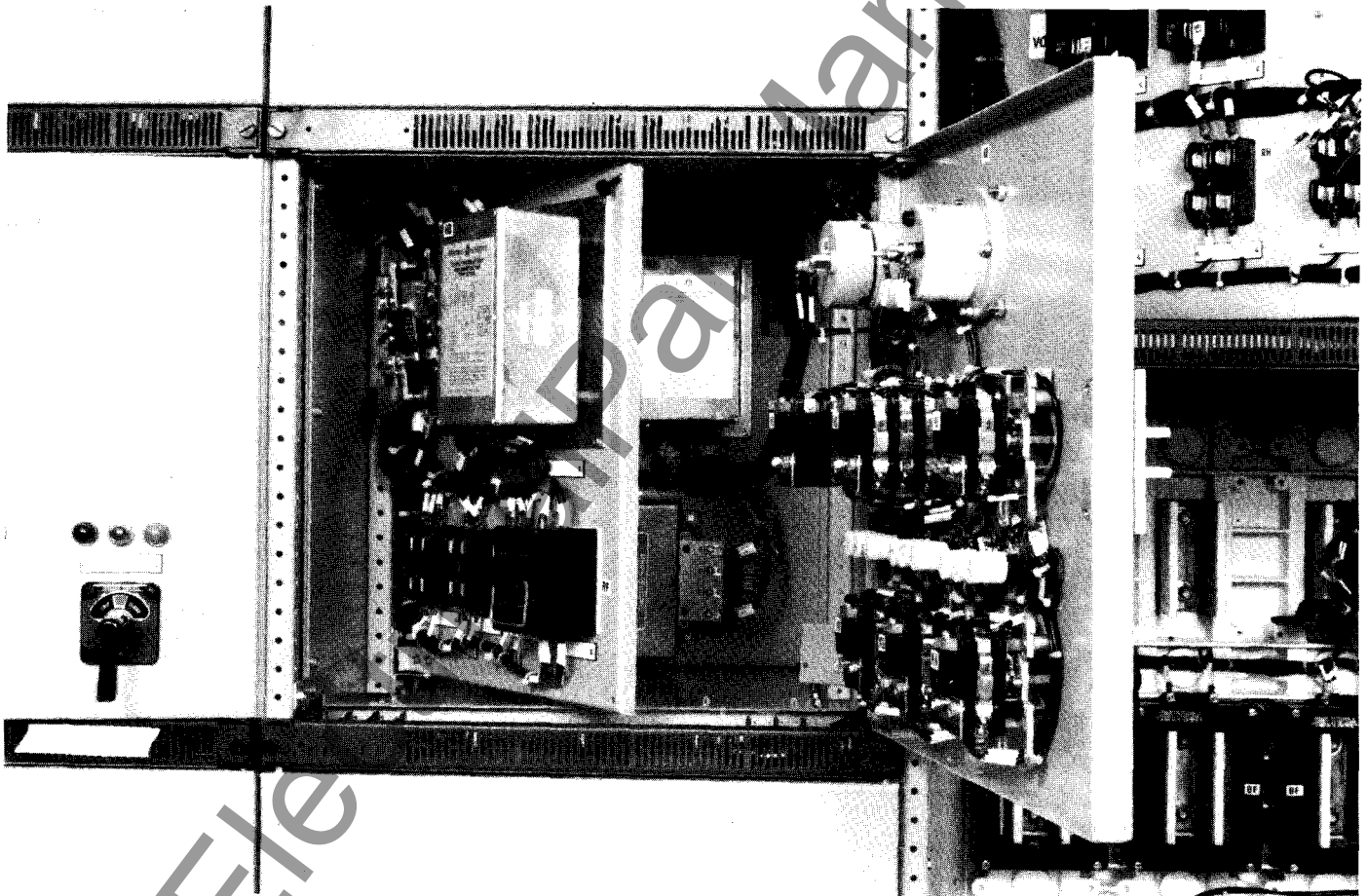

Fig. 3-5. Recessed swinging instrument panel

# AKD-8 Low-voltage Switchgear

## SECTION III—Description

### 3.5—Breaker Compartment

Closed-door drawout circuit breaker compartments, Fig. 3-6, are standard construction with all AKD-8 switchgear equipment. The circuit breaker compartment doors remain closed and latched while the breaker is racked out from the connected position, through test, to the disconnected position.

Breaker compartment doors do not have any ventilation slots, thus protecting operators from hot ionized gases which may be vented by the breaker during circuit interruption. Additionally, the breaker compartment, Fig. 3-7, is enclosed by grounded steel barriers on the top, sides, bottom, and front. In the back a flame-retardant, arc track resistant glass-filled polyester base minimizes the possibility of fault communication between compartments or to the bus.

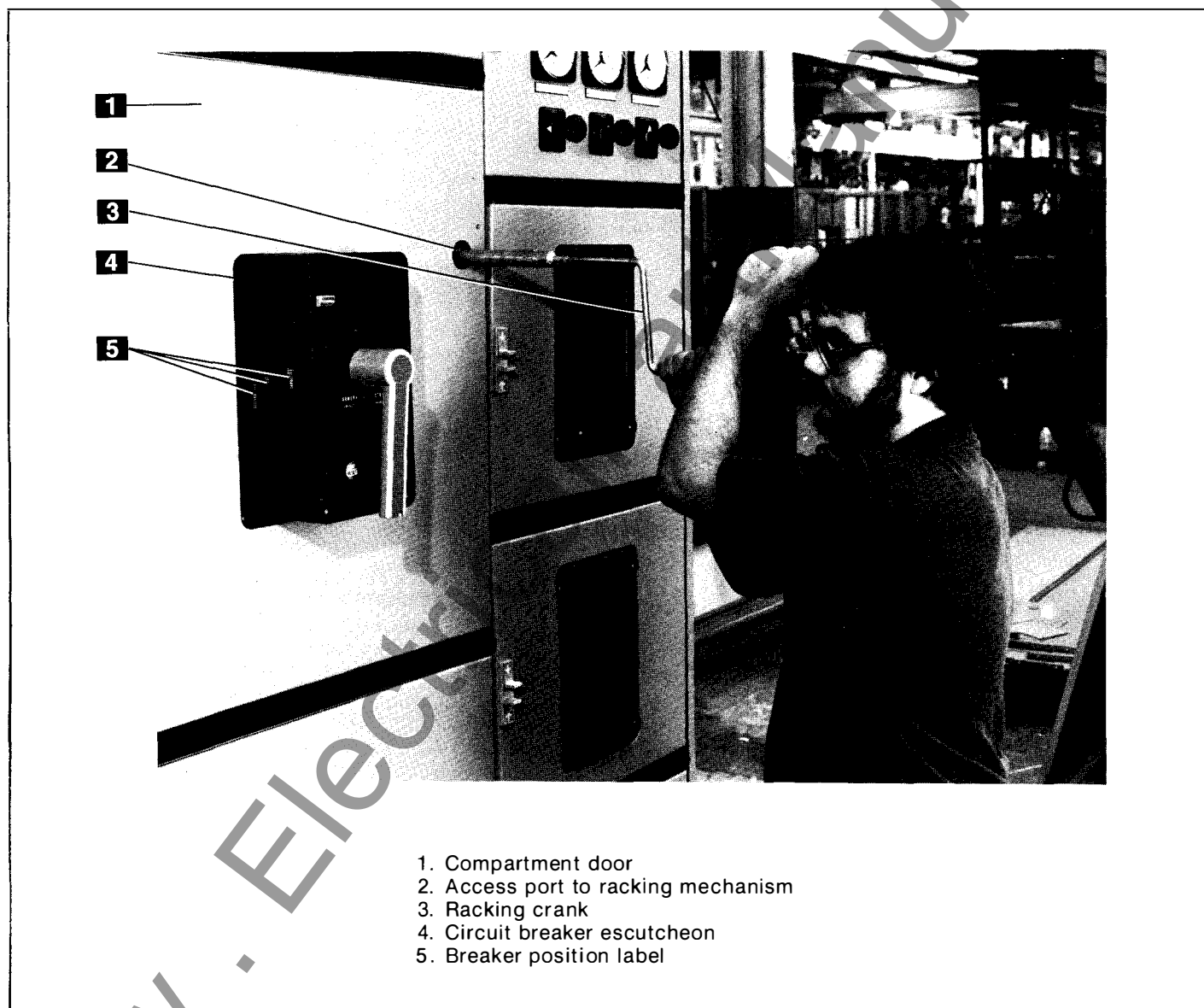

Fig. 3-6. AKR-75 circuit breaker compartment

## SECTION III—Description

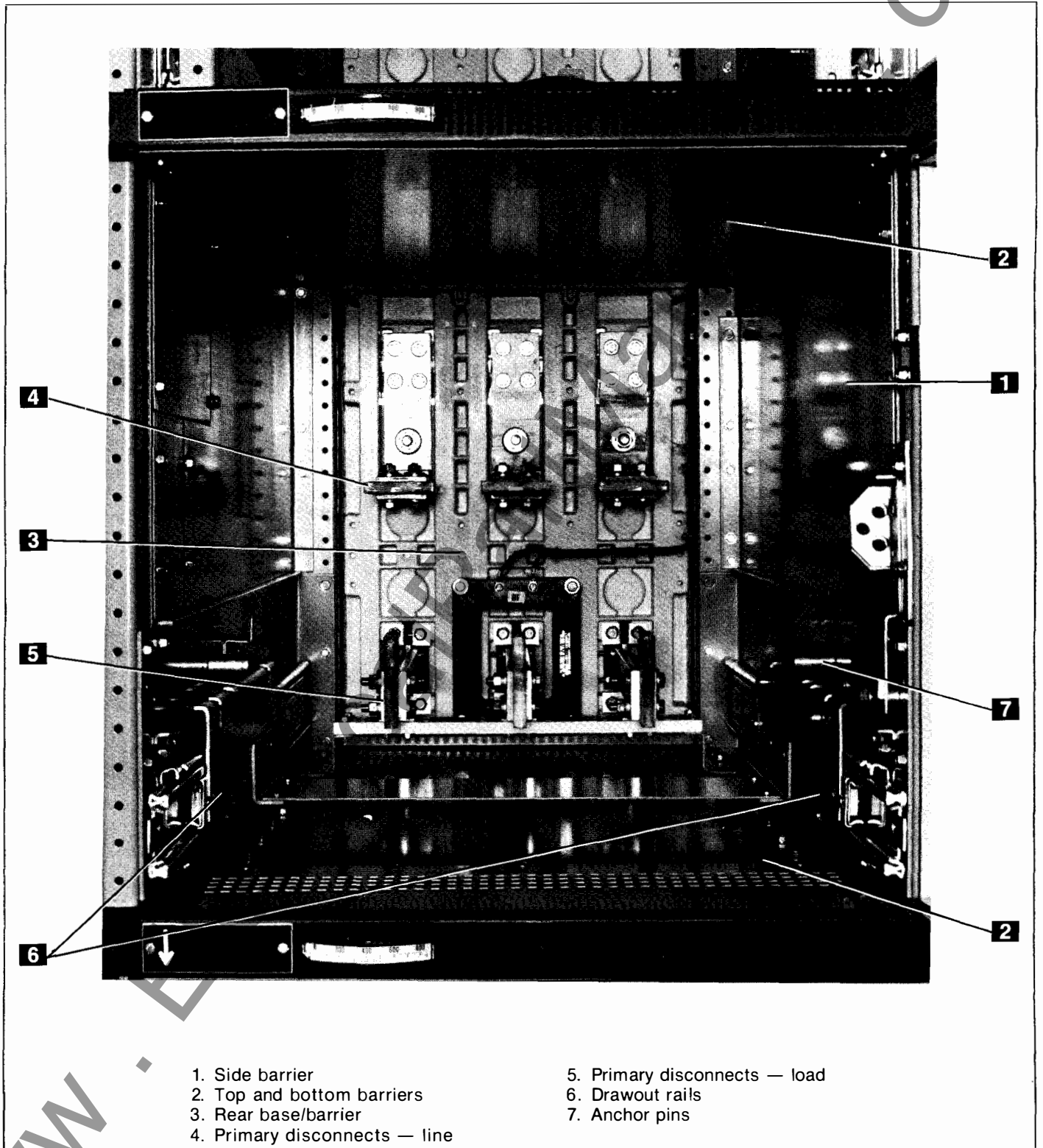

Fig. 3-7. Circuit breaker compartment (22-inch) showing rollout carriage for AKR-30/50/T50 breakers

# AKD-8 Low-voltage Switchgear

## SECTION III—Description

Primary disconnect shutters, Figs. 3-8 and 3-9, are available as options to provide protection against contact with the energized stationary primary disconnects when the breaker is removed from its compartment. Shutters are supplied as standard components in the main and tie breaker compartments of double-ended substations or dual-fed switchgear; additionally, they are standard components in compartments containing reverse-fed devices (i.e. those compartments where the line terminals are the bottom primary stabs). The shutters are constructed from glass-reinforced polyester insulating material.

**NOTE:** If a fuse rollout (FRO) carriage is used with an AKR-75 or AKR-100 circuit breaker whose compartment is equipped with shutters, the FRO compartment will also be equipped with shutters.

Referring to Fig. 3-8, the combination of the stationary barrier (1) and the shutters (movable barriers) prevent frontal access to the primary disconnect line and load power stabs.

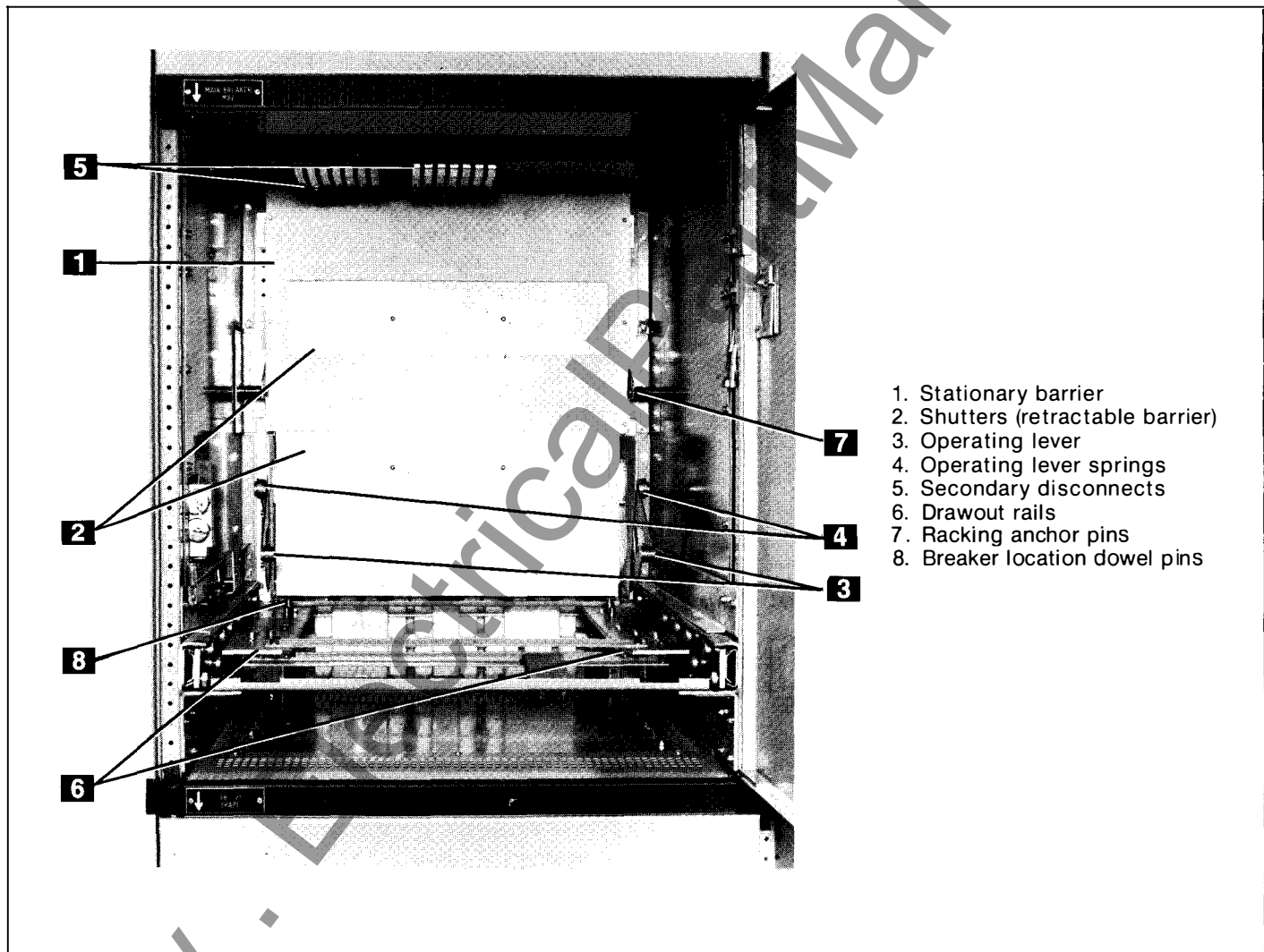

Fig. 3-8. AKD-8 primary disconnect shutter assembly (30-inch wide rollout carriage and compartment for AKR-75/100 breakers)

## SECTION III—Description

The shutters are not retracted as the circuit breaker is racked from the Disconnect Position to the Test Position. This arrangement allows the breaker control circuits to be completed through the secondary disconnects (5), Fig. 3-8, for testing purposes while the shutters remain interposed between the primary power stabs in the equipment and the primary disconnects on the circuit breaker.

As the breaker is racked from the Test Position to the Connected Position, the rear of the circuit breaker frame depresses the shutter operating lever (3) to cause the shutters to be retracted. The operating lever springs (4) cause the operating lever (3) to remain in contact with the circuit breaker frame during this operation.

Figure 3-9 also shows the shutter assembly with the shutters manually retracted to show the location of the primary disconnect stabs (7) behind the shutter assembly. Also shown are the shutter closing springs (6) which cause the closure of the shutters as the breaker is withdrawn from the connected position. These springs are automatically charged as the breaker is racked into the connected position.

Circuit breakers mounted in 22-inch wide compartments (AKR-30, AKR-50, AKRT-50, etc.) are supported on drawout rails (6), Fig. 3-7. The larger AKR-75 and AKR-100 circuit breakers and fuse rollout carriages are installed in 30-inch wide compartments and are supported on drawout rails (6), Fig. 3-8.

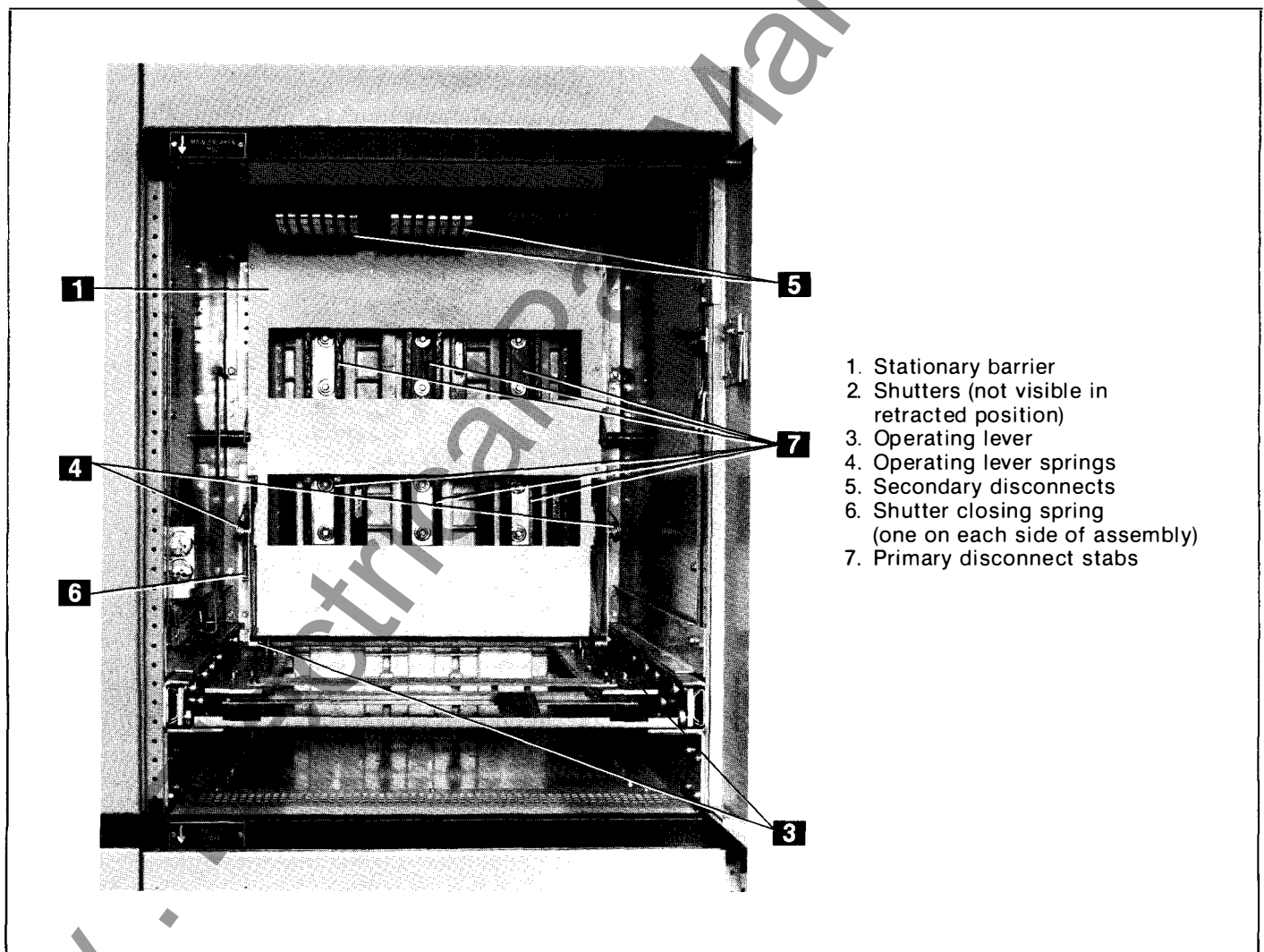
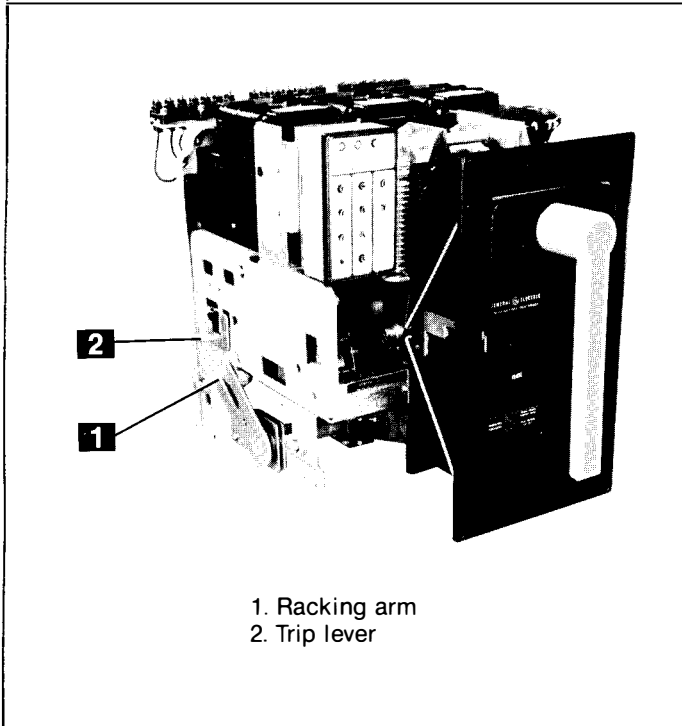

Fig. 3-9. AKD-8 primary disconnect shutter assembly (30-inch wide compartment). Shutters manually retracted — not normal operation.

# AKD-8 Low-voltage Switchgear

## SECTION III—Description



1. Racking arm  
2. Trip lever

Fig. 3-10. AKR-30 circuit breaker

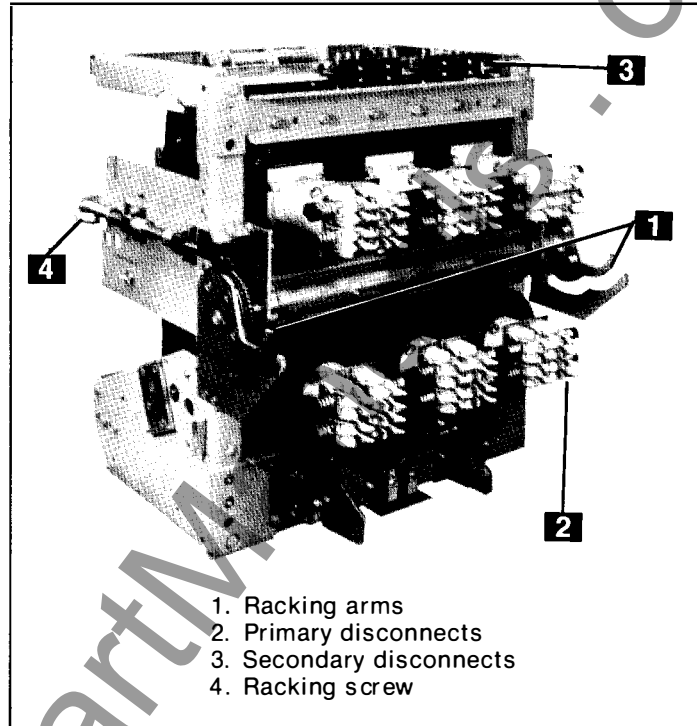

1. Racking arms  
2. Primary disconnects  
3. Secondary disconnects  
4. Racking screw

Fig. 3-11. AKR-75 circuit breaker (rear view)

Note that extra items shown in Figs. 3-8, 3-9, and 3-10 (such as secondary disconnects, current transformers, position switches and ground sensor secondary disconnects) may appear in any compartment or not be included at all, depending on the equipment specified. Primary disconnects are equipped with short-circuit braces when breakers are fused or when extra-deep breaker compartments are used.

The racking arm slots engage fixed racking anchor pins (7), Fig. 3-8, mounted in the breaker compartment. As the racking arms are rotated by operation of the breaker racking crank, the breaker is pulled into the compartment, and locked in its final connected position.

A breaker should always be OPEN when it is moved into or out of the CONNECTED position. As a safeguard, trip lever (2), Fig. 3-10, will cause the breaker to open before the primary disconnects lose contact if a closed breaker is moved out of the CONNECTED position.

All AKR-6D circuit breakers of the same type and rating, which have identical wiring, may be interchanged.

Each breaker compartment has four positions as described below:

1. **CONNECTED POSITION**—The breaker is in operating position, both primary and secondary contacts made, and the door closed.

2. **TEST POSITION**—The secondary contacts are made. If specified, the optional primary disconnect shutters are positioned in front of the primary stabs. Any breaker test which requires control power may be made in this position. The compartment door may be closed in this position and must be closed before charging the spring on a manually operated AKR breaker because an open door will interfere with the breaker handle travel.

3. **DISCONNECTED POSITION**—All primary power and secondary control electrical circuits between the breaker and the equipment are disconnected. The door may be closed. The breaker may be stored in this position with the door closed.

4. **WITHDRAWN POSITION**—The breaker is completely out of its compartment ready for removal from the equipment. The door must be open.

## SECTION III—Description

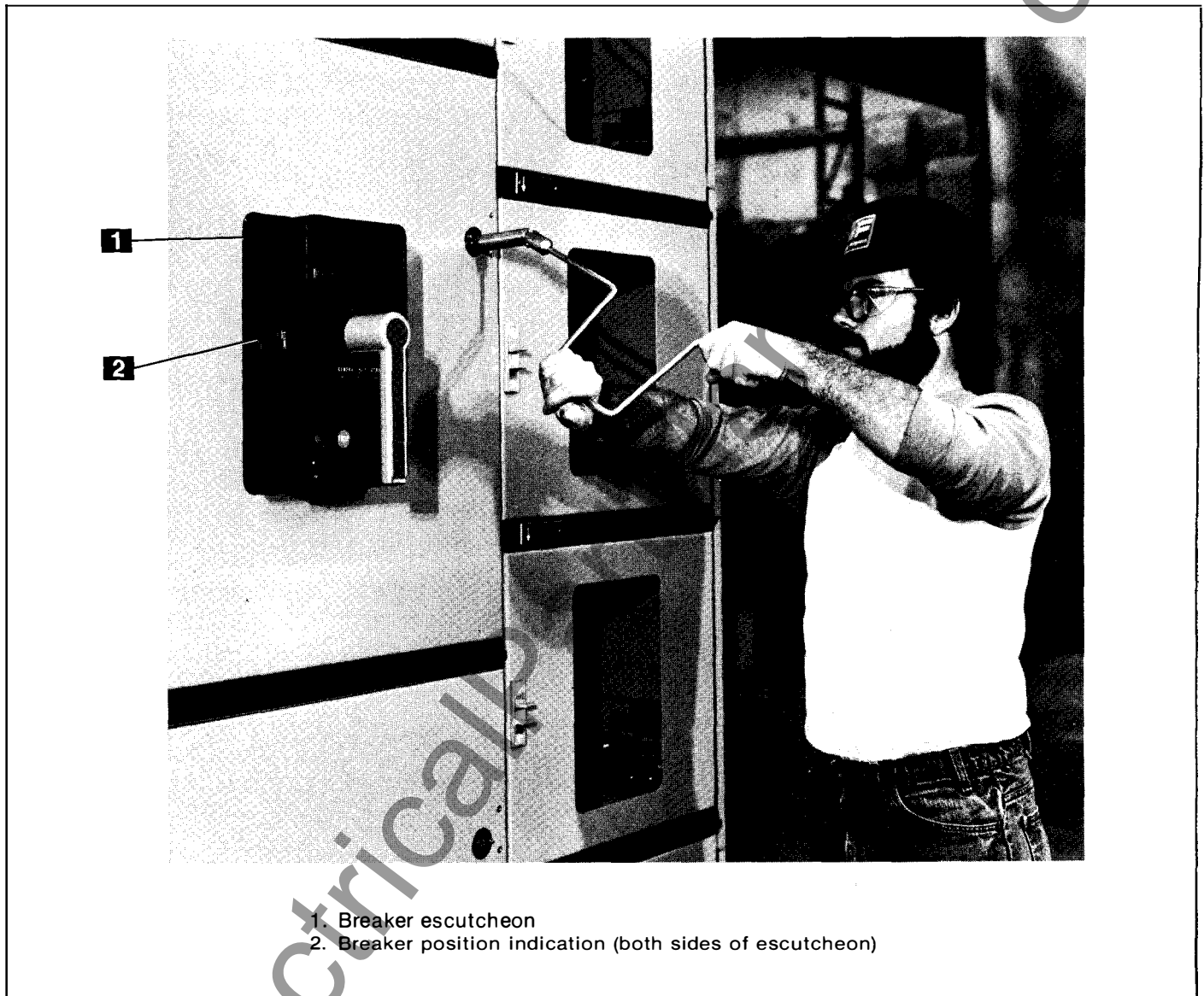

Fig. 3-12. Racking crank for movement of AKR-75 and AKR-100 breakers

Movement of the breaker between the connected, test, and disconnected positions is performed by the use of a racking crank which engages the racking mechanism mounted on the breaker. See Fig. 3-12. Movement to the withdrawn position is manually performed after opening the compartment door.

These positions are illustrated and described more fully in Section V of this instruction book.

**CAUTION:** THE DOOR SHOULD NOT BE OPENED WHEN THE CIRCUIT BREAKER IS CLOSED AND IN THE CONNECTED POSITION. ALTHOUGH THE BREAKER COMPARTMENT DOOR MAY BE OPENED IN ANY POSITION, IT IS RECOMMENDED THAT THE DOOR ONLY BE OPENED WHEN THE BREAKER IS IN THE DISCONNECTED OR WITHDRAWN POSITION.

# AKD-8 Low-voltage Switchgear

## SECTION III—Description

### 3.6—Circuit Breakers

The General Electric AKR Low-voltage Power Circuit Breaker includes spring-operated, stored energy, close and trip mechanisms for either manual or electrical operation.

Five General Electric AKR Circuit Breakers form the complete family of breakers used in the AKD-8 switchgear. These circuit breakers range from 800 to 4000 ampere frame size and are built with the following ratings and characteristics:

#### A. AKR-6D-30 Circuit Breaker (Figs. 3-13 and 3-14)

- 800-ampere frame size
- Standard 30,000-ampere interrupting and short-time capability (480 Volts)
- Four-high stacking, 22-inch wide sections
- Increased IC and short-time rating 42,000 amperes at 480 volts (AKR-6D-30H)

#### B. AKRU-6D-30 Fused Circuit Breaker (Fig. 3-15)

- 800-ampere frame size
- 300- through 1600-ampere integral fusing
- 200,000-ampere interrupting rating
- Four-high stacking, 22-inch wide sections

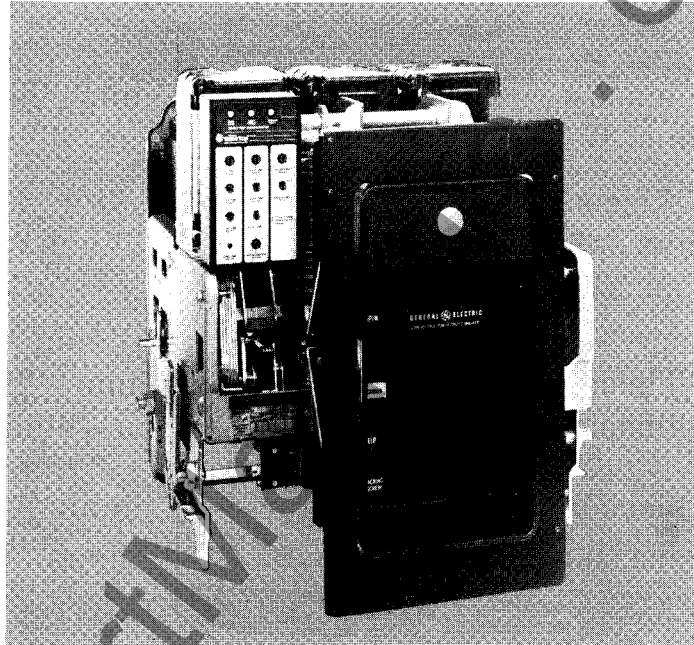

Fig. 3-14. AKR-30 circuit breaker (electrically operated)

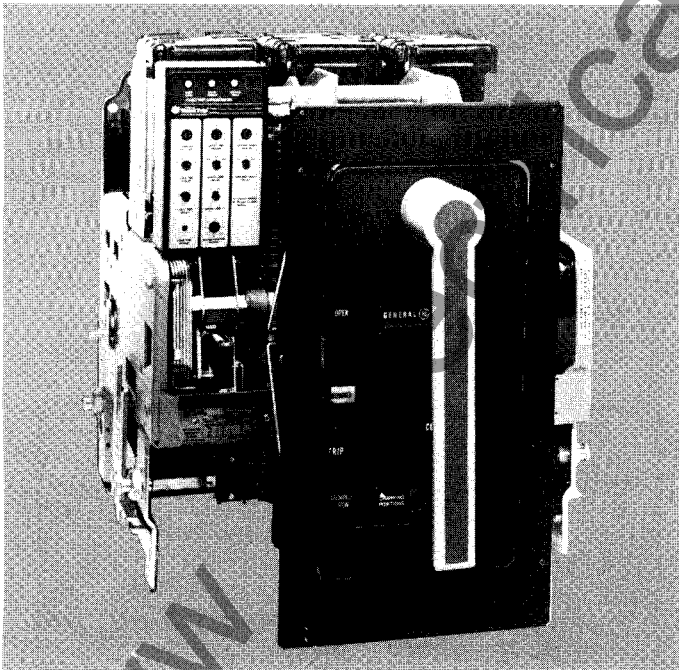

Fig. 3-13. AKR-30 circuit breaker (manually operated)

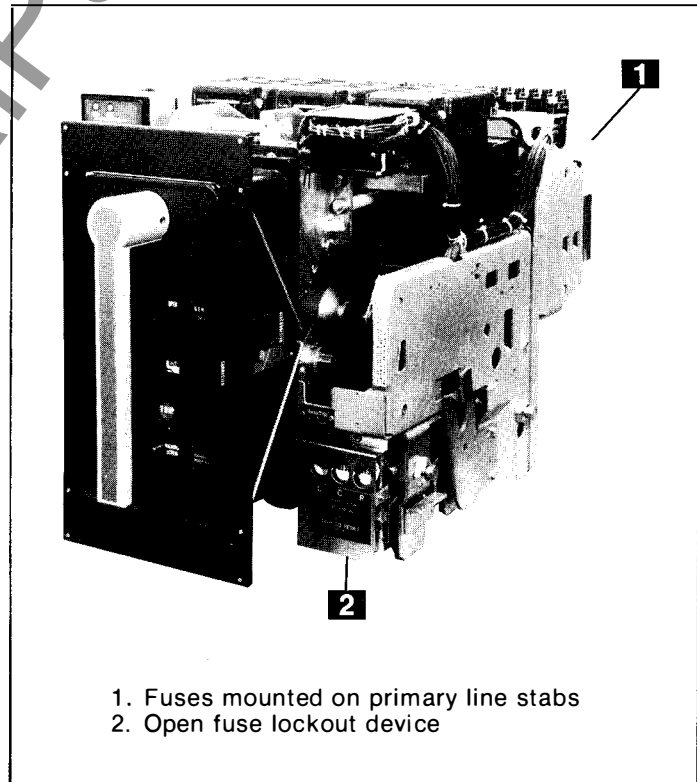

Fig. 3-15. AKR-30 integrally fused circuit breaker

## SECTION III—Description

### C. AKR-6D-50 Circuit Breaker

- 1600-ampere frame size
- Standard 50,000-ampere interrupting and short-time capability at 480 volts
- Four-high stacking, 22-inch wide sections
- Optional 65,000-ampere extended interrupting and short time capability at 480 volts

### D. AKRU-6D-50 Fused Circuit Breaker

- 1600-ampere frame size
- 450 thru 2500-ampere integral fusing
- 200,000-ampere interrupting rating
- Four-high stacking, 22-inch wide sections

### E. AKRT-6D-50H Circuit Breaker

- 2000-ampere frame size
- Standard 65,000-ampere interrupting and short-time capability at 480 volts
- Four-high stacking, 22-inch wide sections (physical loading)

### F. AKR-6D-75 Circuit Breaker (Fig. 3-16)

- 3200-ampere frame size
- Standard 65,000-ampere interrupting and short-time capability at 480 volts
- Two-high stacking, 30-inch wide sections

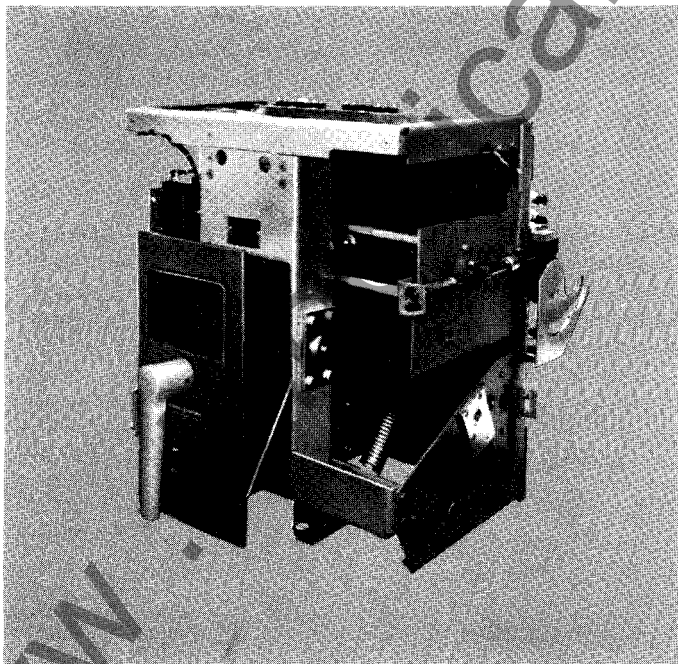

Fig. 3-16. AKR-75 circuit breaker (manually operated)

### G. AKR-6D-100 Circuit Breaker

- 4000-ampere frame size
- Standard 85,000-ampere interrupting and short-time capability at 480 volts
- Two-high stacking, 30-inch wide sections (main-tie)

## 3.7—Fuse Rollout Elements

When the system available short-circuit current exceeds the rating of an AKRT-50, AKR-75 or -100 breaker, current-limiting fuses can be used in series with the breaker to increase the short-circuit rating of the combination. When used, such fuses are housed in a separate drawout compartment located adjacent to the breaker compartment; they are mounted on a drawout carriage similar to a breaker frame and referred to as a fuse rollout element (FRO).

### A. AKR-75 Fuse Rollout Carriage (Fig. 3-17)

- 3000-ampere rating
- 200,000-ampere interrupting rating
- Accepts 2000- through 3000-ampere fusing

### B. AKR-100 Fuse Rollout Carriage

- 4000-ampere rating
- 200,000-ampere interrupting rating
- Accepts 2000- through 4000-ampere fusing

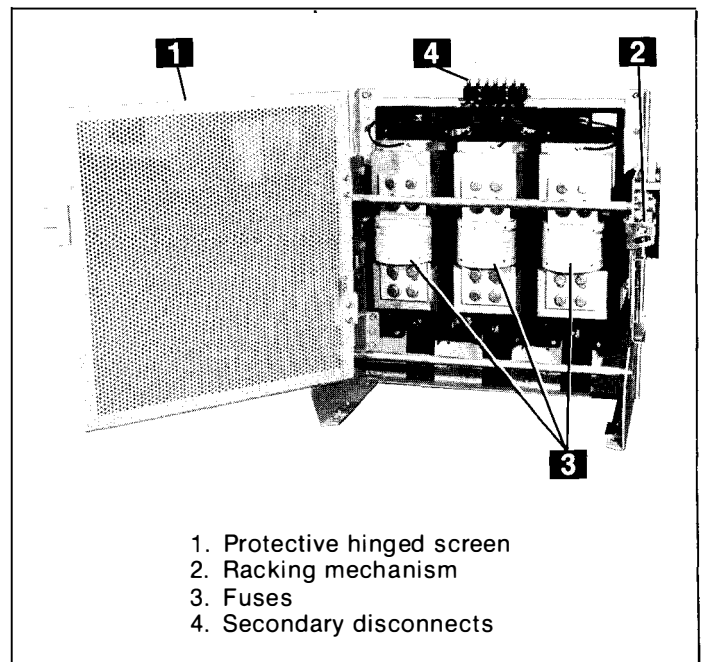

Fig. 3-17. Fuse roll-out carriage

# AKD-8 Low-voltage Switchgear

## SECTION III—Description

### 3-8—Compartments for Future Breakers

When specified, compartments may be supplied for future addition of circuit breaker elements. These compartments are fully equipped with racking tracks or trays, primary disconnects, and ancillary devices as required (i.e. secondary disconnects, accessory devices, etc.) The opening in the breaker compartment door (2), Fig. 3-18, is closed with a snap-in molded cover (3) and a metal barrier (1) is bolted across the face of the compartment to deter accidental contact with energized electrical circuits (i.e. primary disconnect stabs).

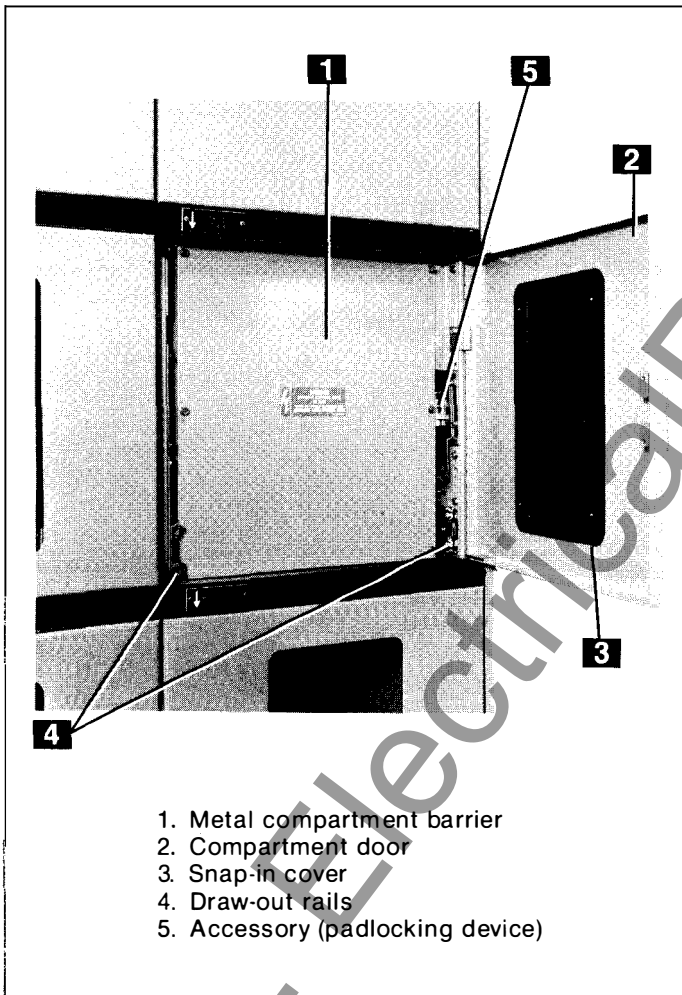

Fig. 3-18. Future breaker compartment

### 3.9—Auxiliary/Transition Sections

Sections may be provided for any one or more of several reasons including:

- Transition to a close-coupled transformer
- Transition to "match and line-up" with existing non-AKD-8 switchgear
- Incoming lines where the circuit is bottom entry and reverse feed is not acceptable (auxiliary)
- Incoming busway where additional termination space is required (auxiliary)
- Mounting and wiring of additional metering, relaying, and control devices requiring more space than available in a standard instrument tray or instrumentation compartment (transition or auxiliary)
- Mounting and wiring of purchaser specified and/or furnished devices (i.e. utility revenue metering equipment, etc.) (auxiliary)

Auxiliary sections may be 22-inch, 30-inch, or 38-inch wide as required to accommodate the space requirements. The compartment doors on the front of the sections are hinged and latched in the same manner as breaker compartment doors.

Generally, transition sections will be 22-inches wide for close-coupling to transformers and "match and line-up" to non-AKD-8 equipments. Transition section width to an AKD-5 or -6 equipment is usually twelve inches.

Power company metering requirements generally require either a 30-inch or 38-inch wide auxiliary section to accommodate the current transformers, kilowatt-hour meters, demand meters, etc. as required by their individual practices, tariff schedules, and/or regulatory commissions.

Figure 3-19 is a partial front view of a typical auxiliary/transition section.

Electric indicating instruments are located in the top compartment (1), Fig. 3-19, (partially shown), an auxiliary relay (2), and fuse cutouts (3) in the middle compartment, and potential transformers (4) and a control power transformer (5) in the lower compartment.

## SECTION III—Description

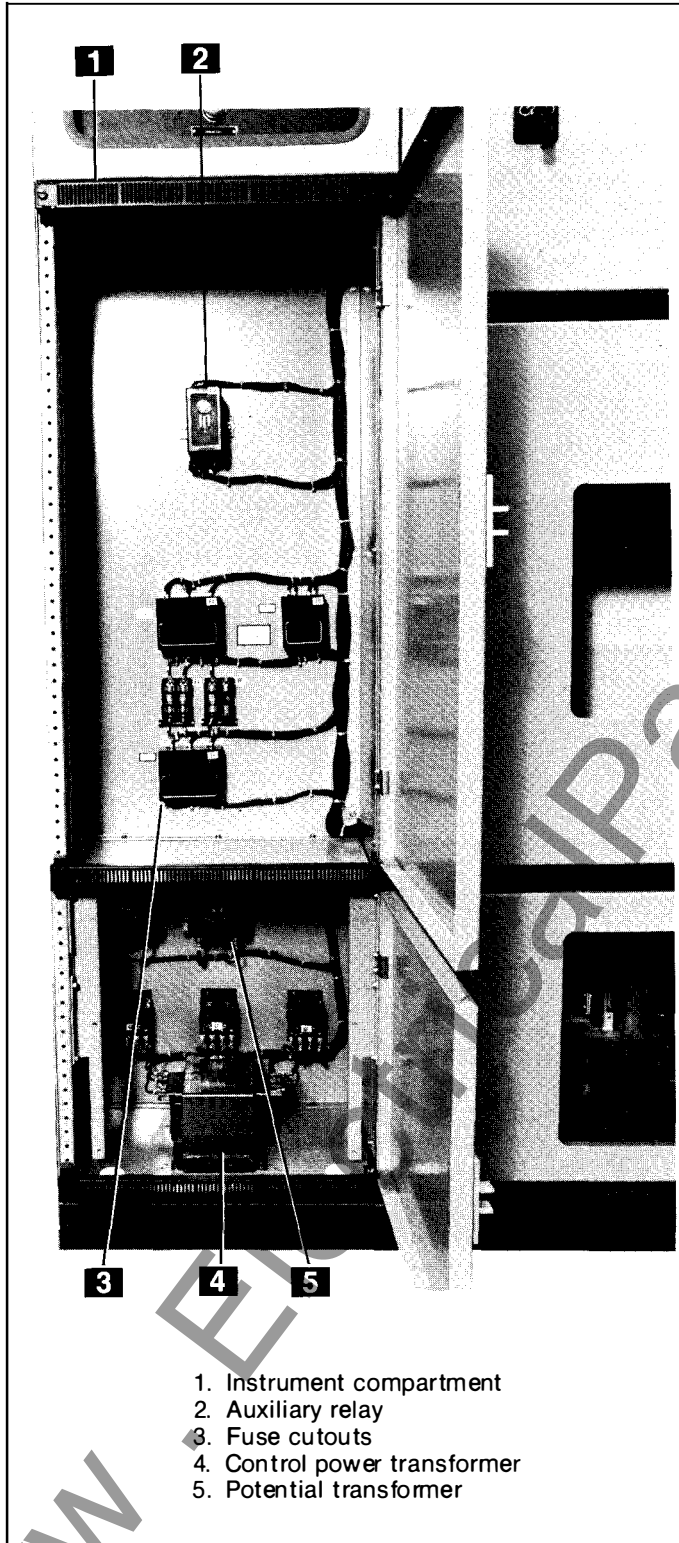

Fig. 3-19. Auxiliary/transition section — partial front view

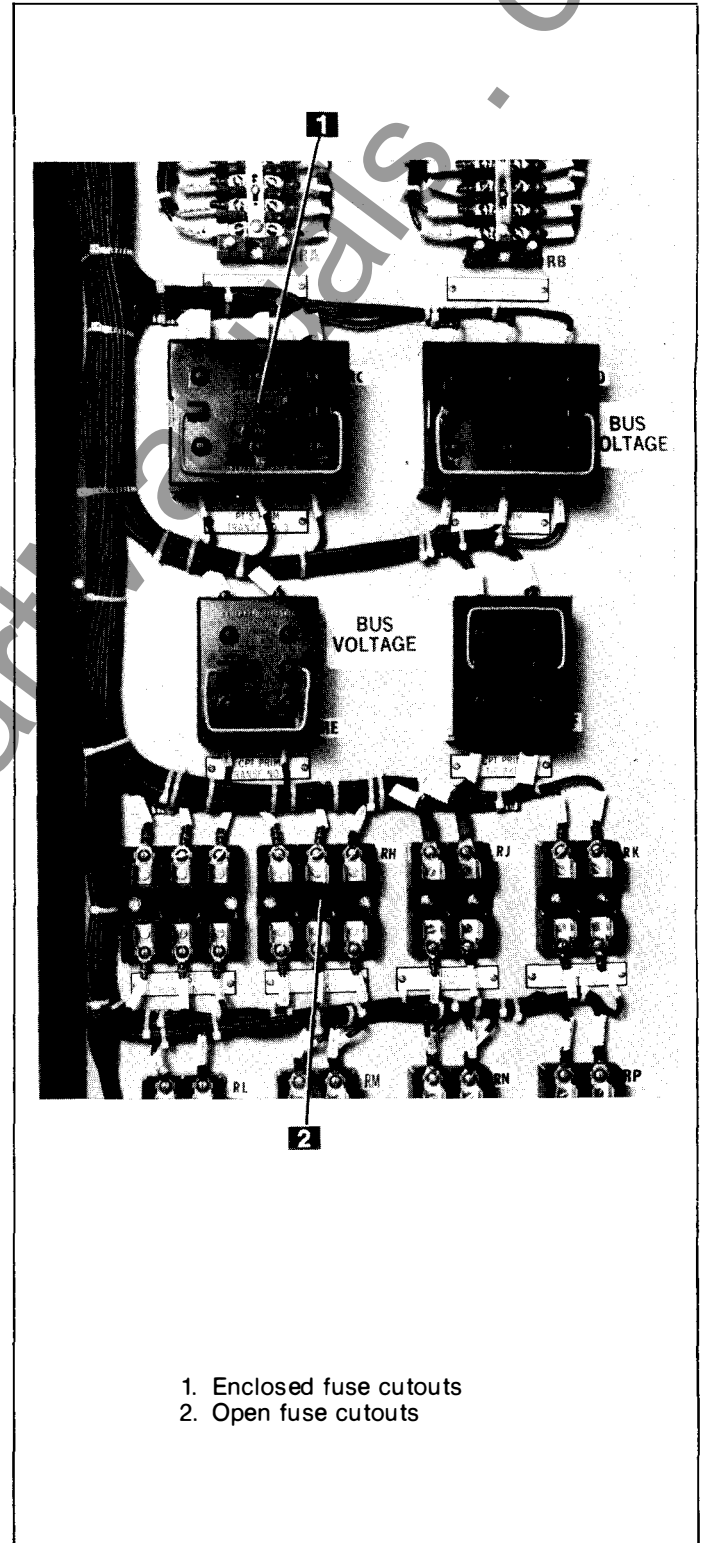

Fig. 3-20. Auxiliary/transition compartments — view of bottom section

# AKD-8 Low-voltage Switchgear

## SECTION III—Description

Figure 3-21 illustrates an auxiliary/transition compartment with switchgear-type relays mounted in semi-flush draw-out cases (2) installed on the compartment door (1). Space in the compartment has been used for storage of spare power fuses (3). The horizontal busbars are supported on power connector blocks welded to the vertical busbars. All bolted supports and connections are accessible from the rear for maintenance. The bus area is fully isolated from the breaker, instrument and auxiliary compartments by the molded bases or glass polyester sheet.

### 3.10—Bus Area

The bus area, Fig. 3-22, contains the main horizontal bus (2) and vertical riser busbars (3) for the particular section. The vertical busbars are nested in and bolted to recesses molded in the back of the glass-filled polyester bases (1) which form the rear wall of the breaker compartment. The horizontal busbars are supported on power connector blocks welded to the vertical busbars. All bolted supports and connections are accessible from the rear for maintenance. The bus area is fully isolated from the breaker, instrument and auxiliary compartments by the molded bases or glass polyester sheet.

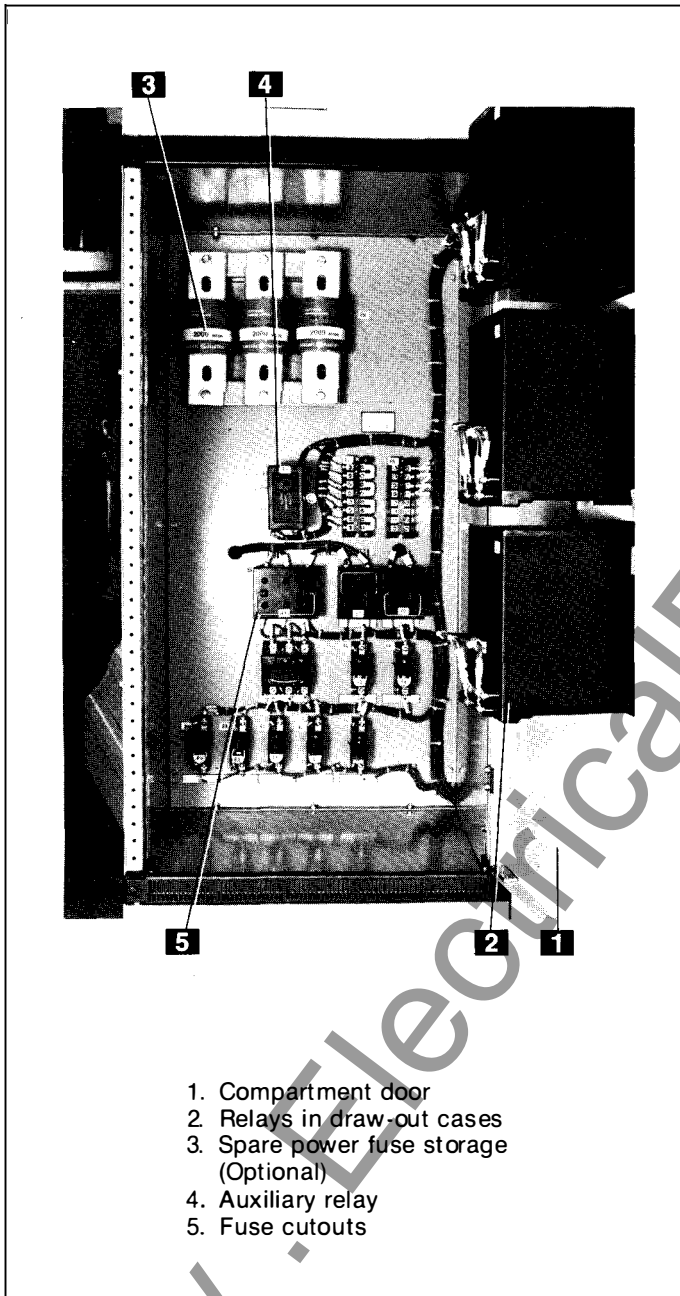

1. Compartment door
2. Relays in draw-out cases
3. Spare power fuse storage (Optional)
4. Auxiliary relay
5. Fuse cutouts

Fig. 3-21. Auxiliary/transition compartments — view of top section

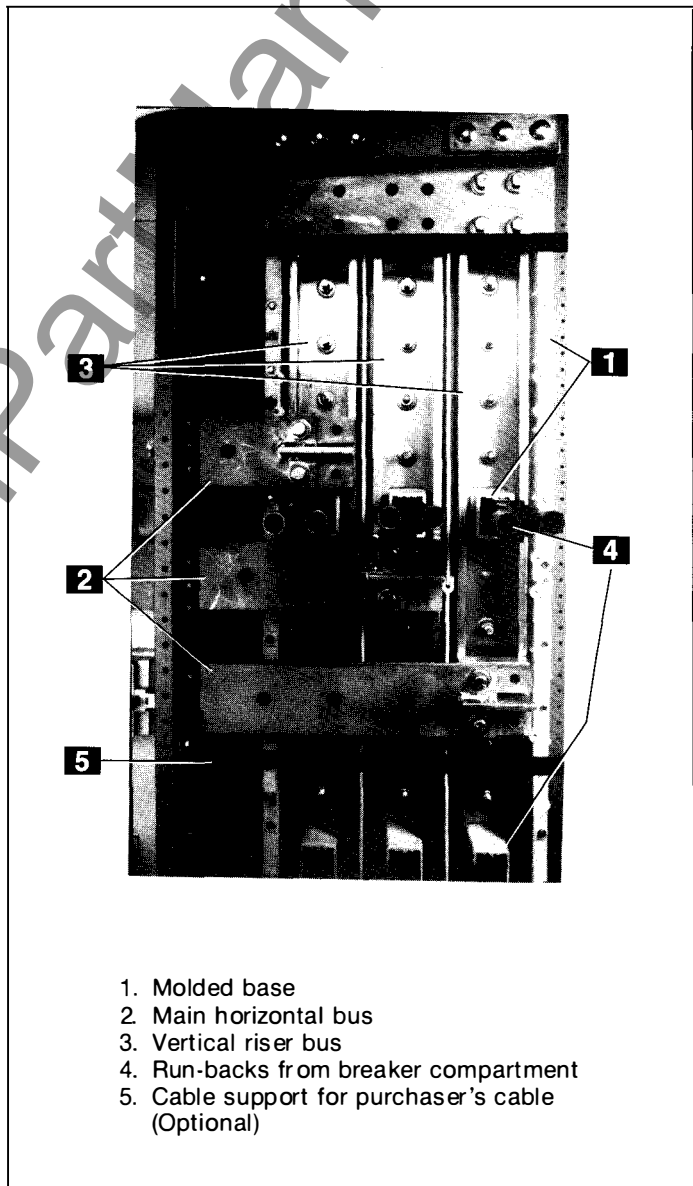

1. Molded base
2. Main horizontal bus
3. Vertical riser bus
4. Run-backs from breaker compartment
5. Cable support for purchaser's cable (Optional)

Fig. 3-22. Bus construction

## SECTION III—Description

### A. Busing System

The standard construction is open bus. A barrier system (Iso-Barrier) that isolates the main and vertical busbars from the cable area is available as an option if specified. All run-backs (load-side power conductors) from the breaker compartment to the cable termination area are coated with an epoxy insulation.

For maximum dependability and short-circuit strength, all vertical buses are nested in and bolted to a molded, glass-reinforced polyester base. This provides a rigid support structure and places solid insulation between the adjacent bus bars. Standard bus bar bracing is for 50,000 amperes, RMS symmetrical; bracing up to 200,000 amperes, RMS symmetrical is available as an option.

The typical arrangement with an all-welded aluminum bus is shown in Fig. 3-23. Bolts at bus joints are used only for mechanical support or at connections which must be made in the field. The bolts present on welded aluminum joints are only for supporting and positioning busbars prior to welding. Once the joints are welded, these bolts perform no further function; however, it is recommended that the bolts be left in place.

The bus system is also available with copper conductors as an option. This system utilizes bolted connections between all joints and to the breaker compartment run-ins. The riser bus power connectors, to which the main horizontal bus are bolted, are welded to the riser bars.

The standard bracing for either the welded aluminum or the bolted copper bus systems is 50,000 amperes, RMS symmetrical.

Aluminum bus bars between sections are bolted and then welded together to provide one continuous aluminum main bus. In general, when the switchgear equipment has no more than four sections or does not exceed 10 feet in length, it will be shipped as one complete lineup. In such cases, the only field assembly would be to a close-coupled transformer if the switchgear were part of a Load Center Unit Substation. If, because of shipping and/or handling considerations, the equipment cannot be handled in one piece, it can be split into two or more line-ups at the factory. The individual shipping splits require both mechanical and electrical connections between sections to be made in the field. At these shipping splits, provisions are made for bolting all buses and making the necessary electrical and mechanical connections. These are described in Section IV, of this publication.

On main and tie breakers, the bus area, Fig. 3-23, is divided into an upper (4) and lower (6) section by an isolation barrier (5) built into the molded base. For the main circuit breakers, the upper section contains the incoming line bus (4). This bus is fed from the bus connections (2) in the transition section. The lower section of the bus area contains the load side main bus (6) (protected by the main breaker) which feeds all

sections of the switchgear equipment. Similarly, barriers at tie breakers isolate the two main bus sections from each other.

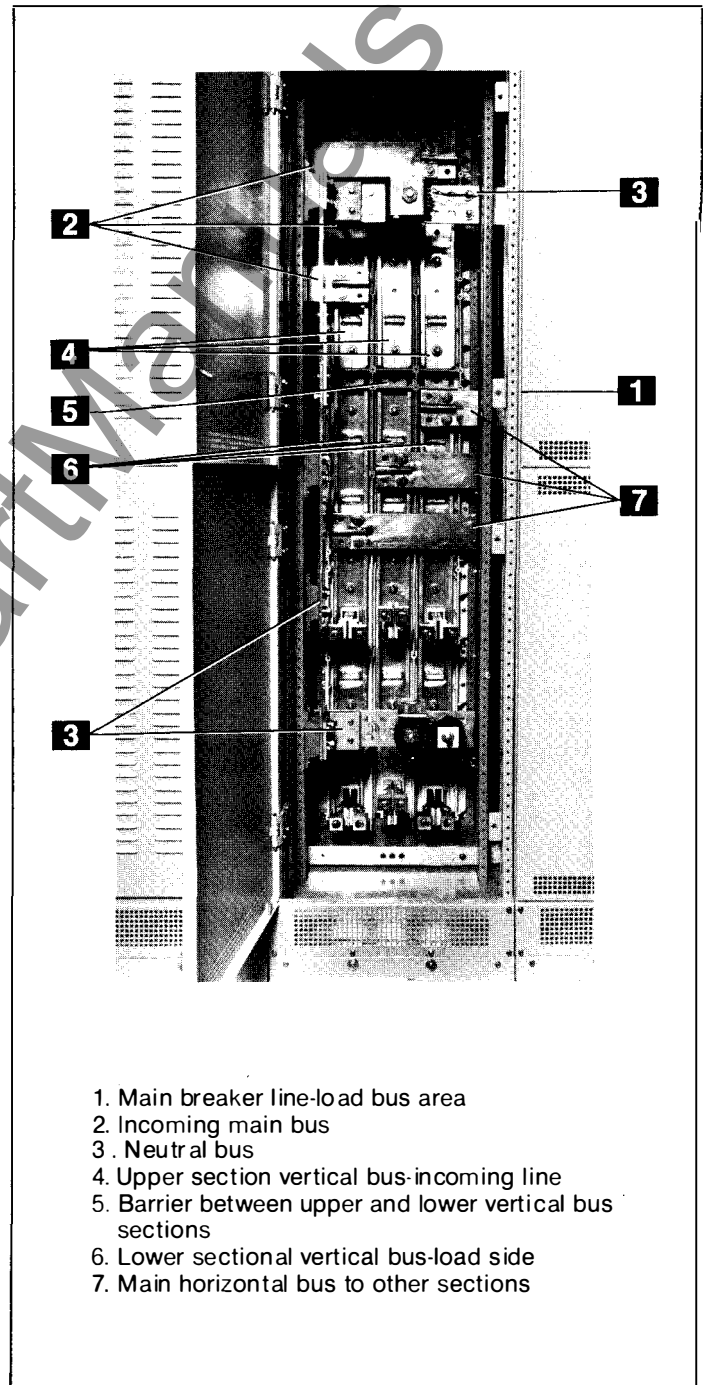

Fig. 3-23. Main breaker bus arrangement

# AKD-8 Low-voltage Switchgear

## SECTION III—Description

### B. INSUL-BAR Bus System™

A bus insulation system, Fig. 3-24, that fully insulates and isolates each phase of the main and vertical buses is optionally available for AKD-8 switchgear when specified. With the INSUL-BAR system, there are no live connections accessible in the rear of each section except the cable lugs.

A vertical barrier (2), Fig. 3-25, between the transition section (1) and the first breaker section is furnished where specified.

The buswork in the device/auxiliary/transition sections is not insulated at the termination points to the other connected equipments such as transformers, busway, or existing equipments.

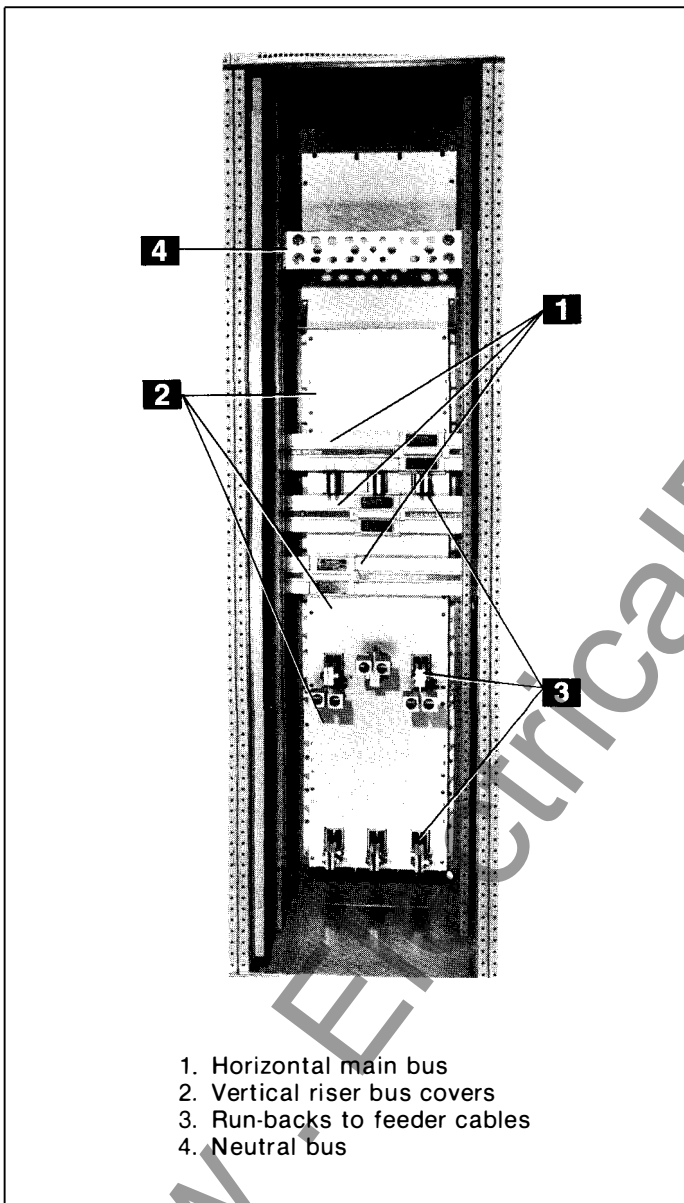

Fig. 3-24. Insul-Bar insulation/isolation system

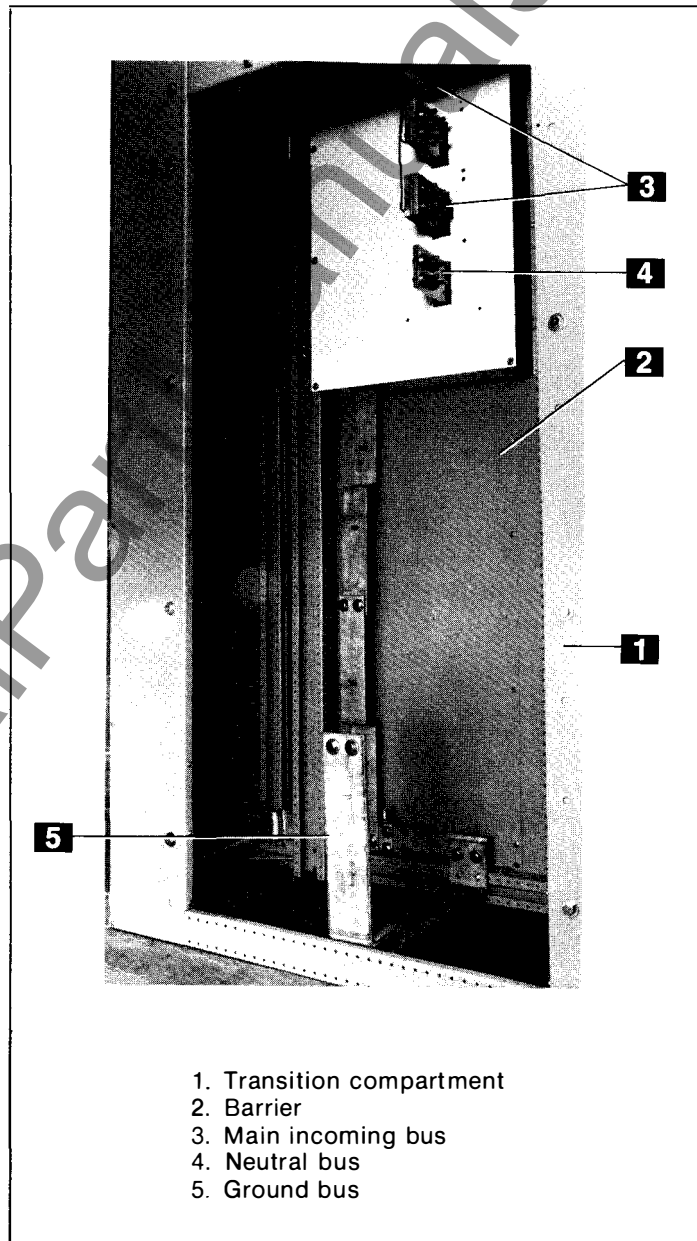

Fig. 3-25. Transition section

## SECTION III—Description

Insulation and isolation of the vertical riser bus bars (2), Fig. 26, is provided by mounting covers (3) over the bus bars as shown in Fig. 3-26. (The cover on the top portion of the vertical bus has been removed for illustrative purposes.)

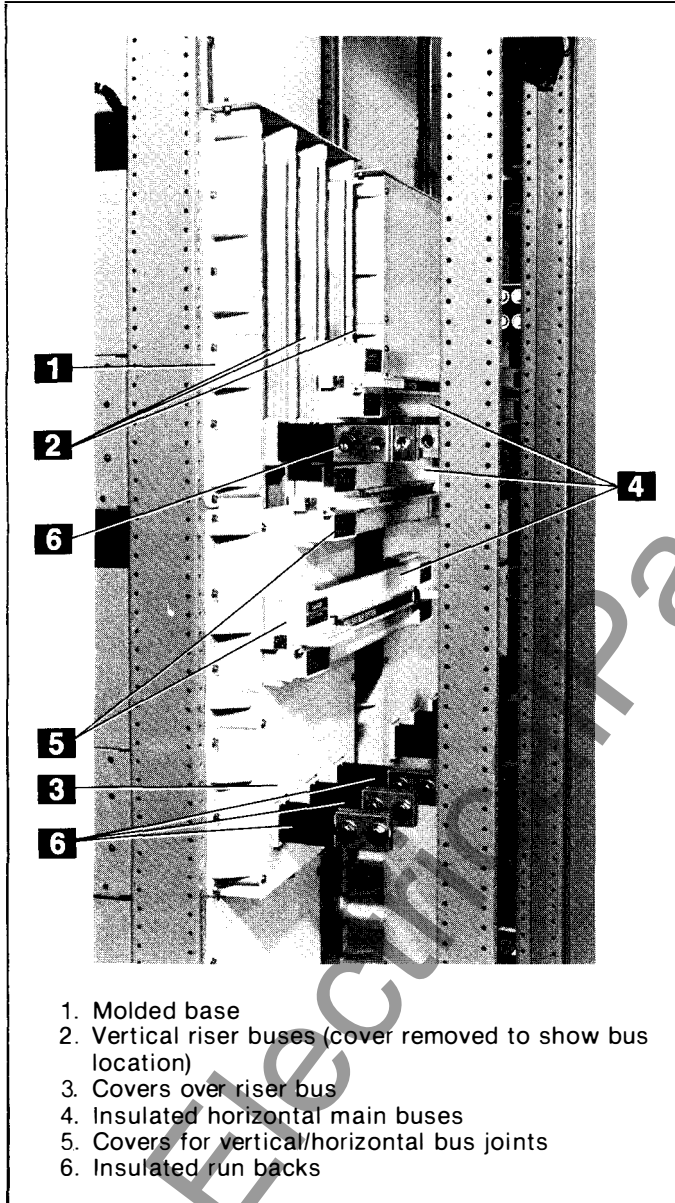

Fig. 3-26. Insul-Bar insulation/isolation bus system

The covers are constructed from glass-reinforced polyester insulating material. Insulation of the horizontal main bus bars (4) is achieved by a powder coating of insulating material. Impact-resistant Noryl® covers are attached to prevent damage to the insulation by falling wrenches or other tools during installation or maintenance work.

Figure 3-27 illustrates the various components comprising the insulation/isolation system for the horizontal main bus bars. The top bar (2), Fig. 3-27, on the right shows the aluminum bar prior to fluidized bed application of the powder coating. The middle bus bar (3) shows the aluminum bar with the fused epoxy insulation coating. The bottom bus bar (4) shows the insulation system complete with Noryl® protective cover and the joint cap held in place with captive spring clips.

**NOTE:** The aluminum bus bars would normally be welded at the power connectors to the vertical riser bus bars; this was eliminated for illustrative purposes.

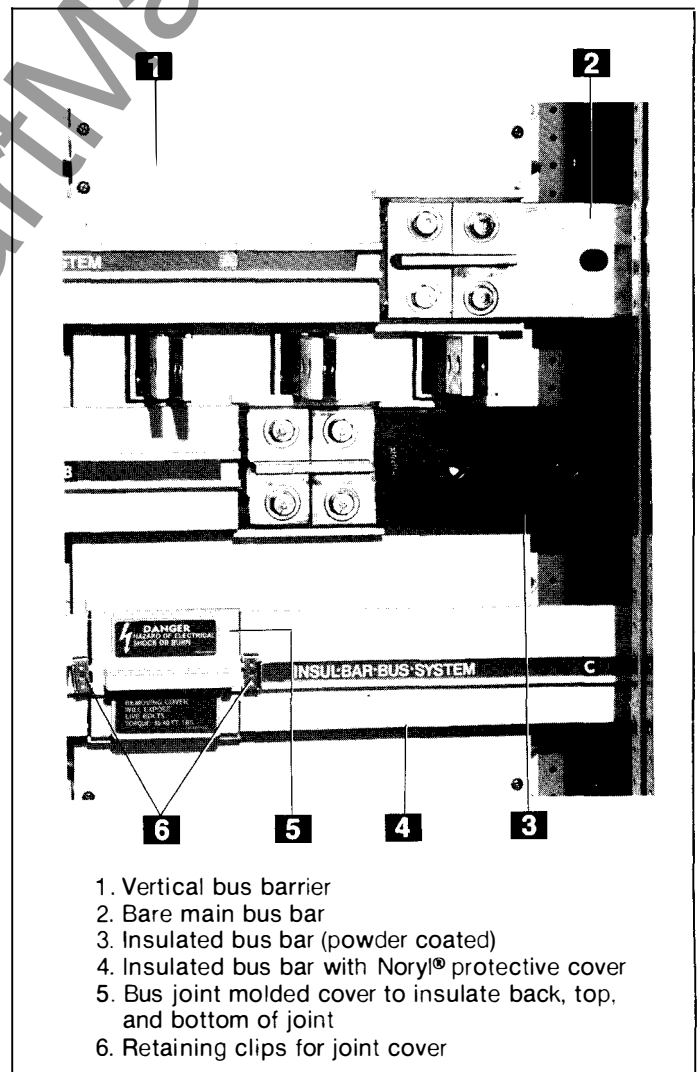

Fig. 3-27. Insul-bar horizontal bus insulation system

# AKD-8 Low-voltage Switchgear

## SECTION III—Description

### 3.11—Feeder Cable and Busway Compartment

The rear cable and terminal compartment, Fig. 3-28, provides for cable installation and terminations. The cable bending space meets the requirements of the 1981 National Electric Code. Various arrangements of single or double cable terminals are provided, depending upon the purchaser's requirements.

When specified, racks (1), Fig. 3-28, for the support of feeder cables are located in the cable compartment. The actual support of the cables is provided by lashing them to these racks.

Also located in the cable compartments are provisions for terminating control wire cables between external devices and control circuits within the switchgear equipments. See

Fig. 3-29. When furnished, the terminal boards (2), Fig. 3-29, for such connections are mounted in an enclosed vertical wiring trough mounted on the side of the cable compartment. The trough is of steel construction with bolted cover (4) to provide an isolation barrier between the control wiring (1) and the adjacent power cables.

A neutral bus, insulated from ground, is provided in the bus area on switchgear designed for four-wire systems. As shown in Fig. 3-30, the neutral bus (1) is located near the top of the cable compartment. It includes provisions for terminating the neutral conductor of four-wire feeder cables and also direct mounting of the neutral CT as required for those feeder system circuit breakers having an integral ground-fault trip function.

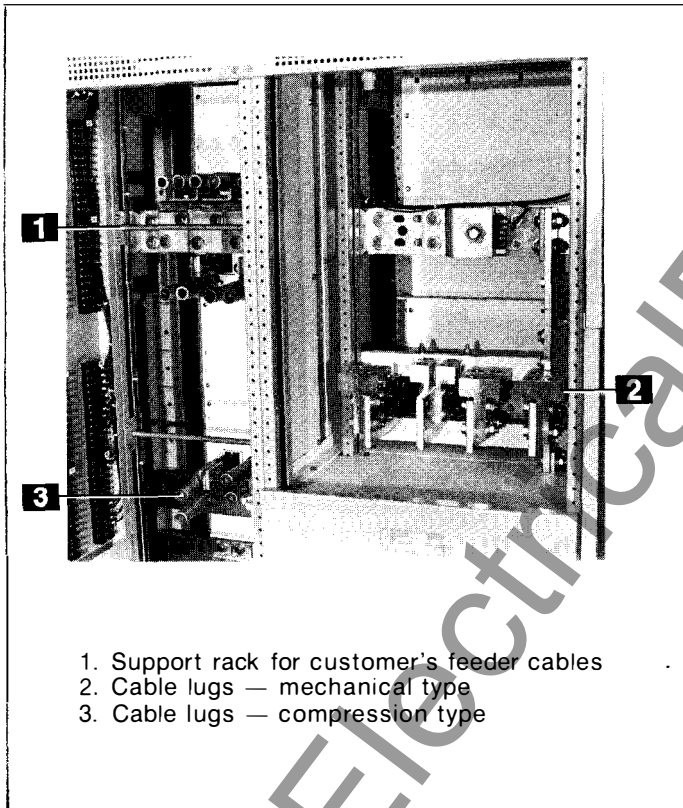

Fig. 3-28. Cable termination provisions

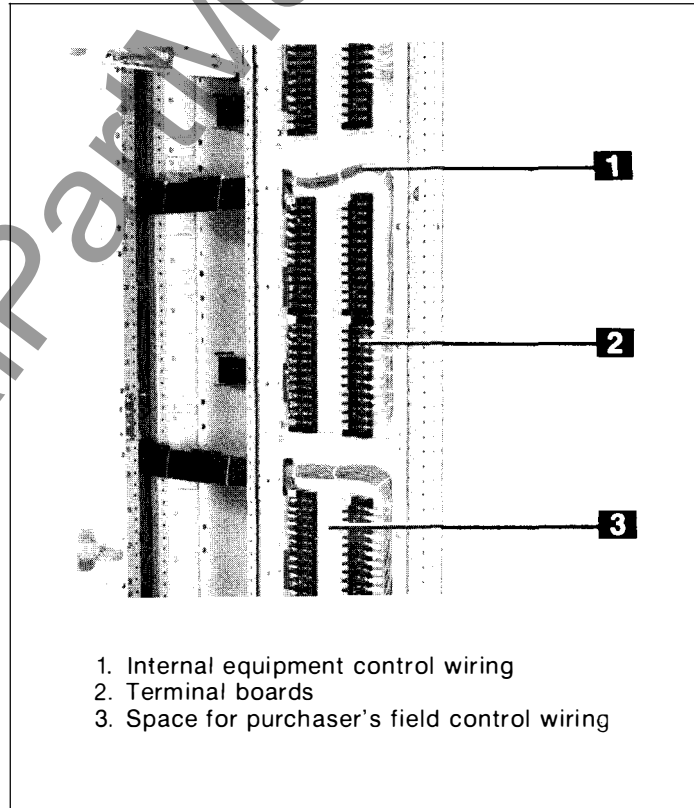

Fig. 3-29. Control wiring termination trough

## SECTION III—Description

### 3.12—Ground Bus

All General Electric AKD-8 switchgear sections are grounded to the internal equipment ground bus (4), Fig. 3-30, located at the bottom of the cable compartment.

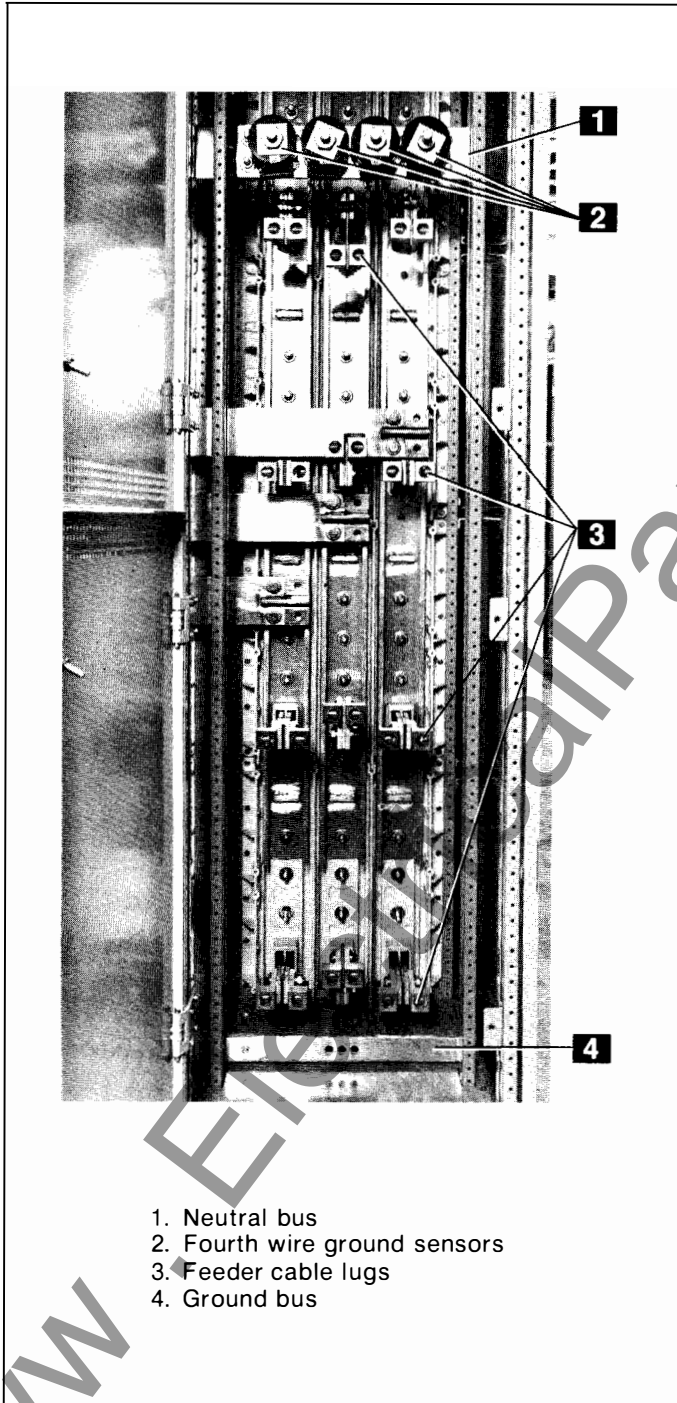

Fig. 3-30. Cable termination compartment

### 3.13—AKD-8 Outdoor Switchgear

AKD-8 switchgear designed for outdoor installations is fully weatherproofed. See Fig. 3-31 and 3-32. A weatherproof housing completely encloses the switchgear and is provided with a walk-in front aisle for easy access to all controls and instruments.

A light with wall switch (2), Fig. 3-32 and a 115-volt convenience outlet (4) are standard devices supplied with outdoor switchgear equipments. Also included in the walk-in front aisle area are the breaker lifting device (2), Fig. 3-31, and storage provision for the hoist operating crank (3).

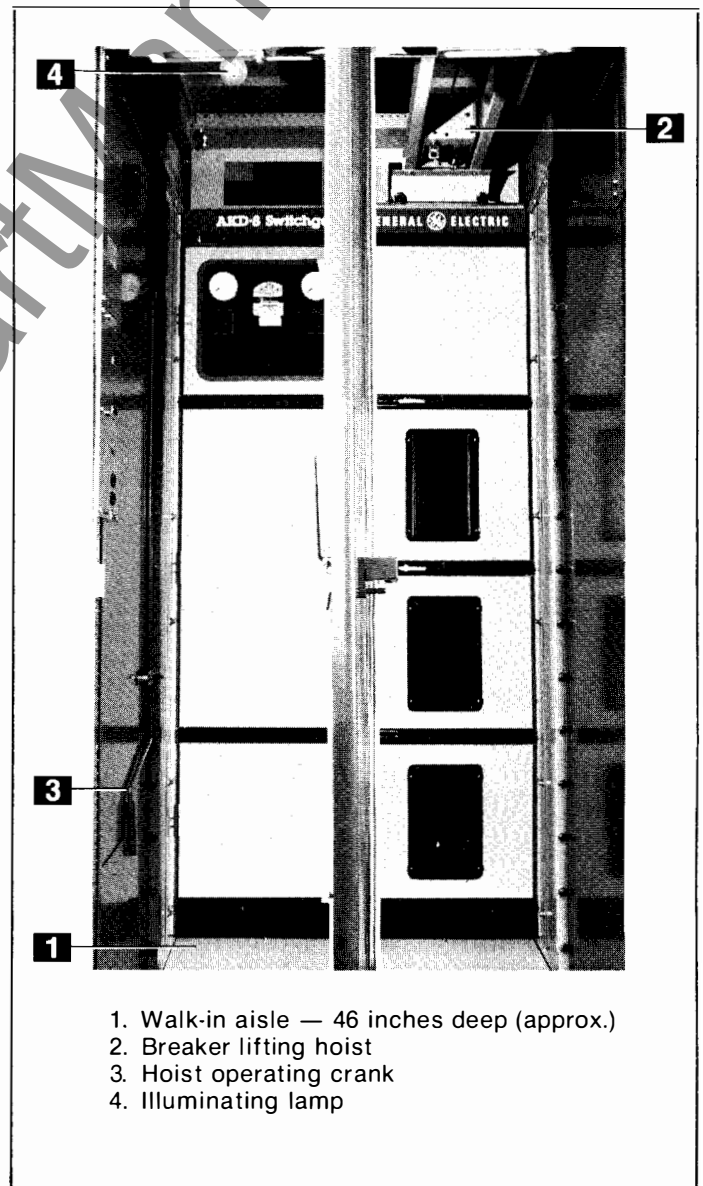

Fig. 3-31. AKD-8 Switchgear outdoor enclosure

# AKD-8 Low-voltage Switchgear

## SECTION III—Description

Space heaters (3), Fig. 3-33, are provided as standard equipment. They provide protection against condensation of moisture that could, in combination with air-borne contaminants, deteriorate insulation or cause corrosion. One 250-watt, 115-volt, ac heater is located on the floor of the bus compartment of each outdoor switchgear section. The heaters should be energized at all times to prevent condensation within the switchgear.

Heaters are fed by the control power transformer. The on-off control switch (3), Fig. 3-32, is located in the walk-in front aisle.

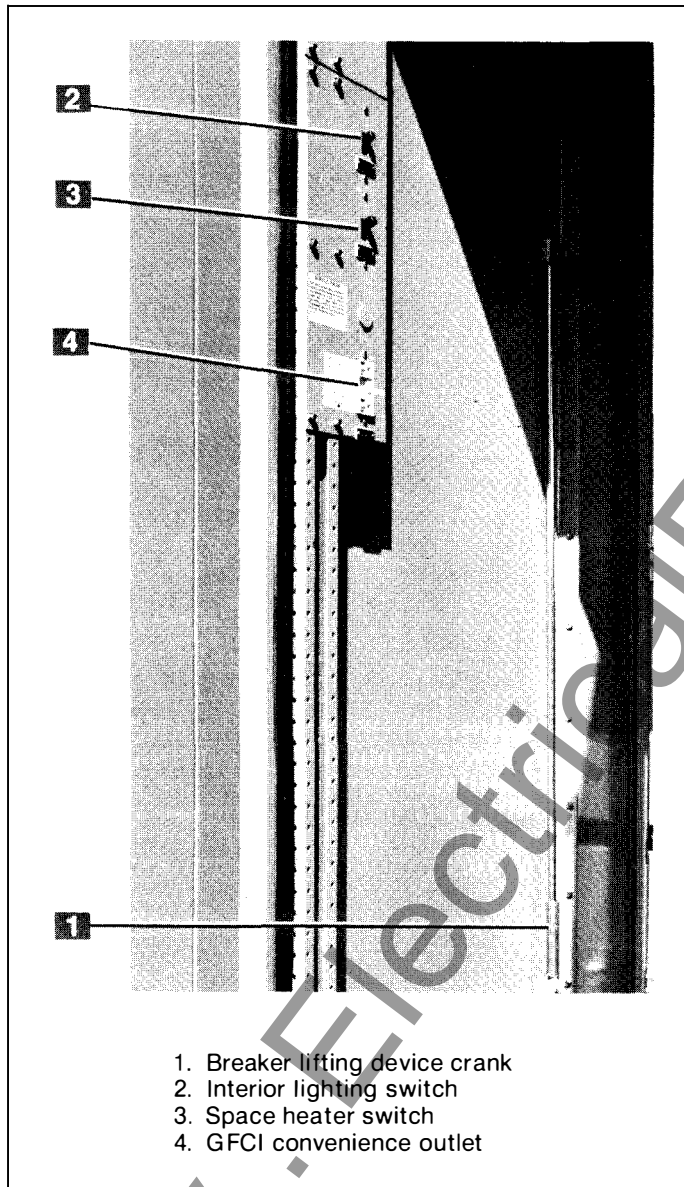

Fig. 3-32. Outdoor enclosure accessories

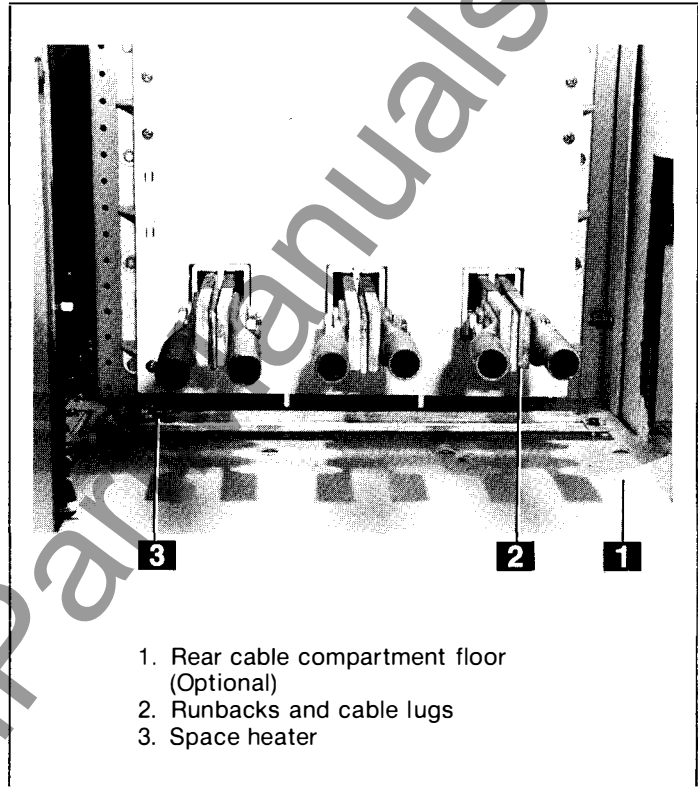

Fig. 3-33. Location of space heater

# SECTION IV—Equipment Installation

## 4.1—General

This section contains complete instructions for installing General Electric AKD-8 Low-voltage Switchgear.

**CAUTION:** EQUIPMENT INSTALLATION PERSONNEL MUST BE THOROUGHLY FAMILIAR WITH THIS INSTRUCTION MANUAL AND ALL ARTICLES OF THE NATIONAL ELECTRICAL CODE APPLICABLE TO THE INSTALLATION OF THIS SWITCHGEAR. IN ADDITION, ALL DRAWINGS, BOTH MECHANICAL INSTALLATION AND ELECTRICAL, MUST BE UNDERSTOOD AND STRICTLY FOLLOWED TO PREVENT DAMAGE TO THE SWITCHGEAR OR EQUIPMENT BEING PROTECTED BY THE SWITCHGEAR.

**NOTE:** Before installation work is started, it is important to review all of the drawings provided, including the General Electric equipment arrangement drawings, site installation drawings, elementary and remote connection drawings, mechanical connection drawings, and the summary of equipment list.

All expendable hardware for shipping purposes only, is painted yellow or tagged with yellow adhesive tape (as shown in Fig. 2-4) and may be discarded at completion of installation phase.

### A. Site Location

In general, the location of the switchgear equipment will have been predetermined during the specification and/or procurement of equipment phases. Indoor locations within buildings impose certain requirements which must be met so that the switchgear may operate efficiently with a minimum of maintenance.

In locating the AKD-8 Switchgear, adequate aisle space must be provided at the front and rear of the equipment to ensure proper ventilation of the equipment and to allow service and maintenance of the equipment with the front and rear doors open. The recommended aisle space is shown on the floor plan supplied with the equipment drawings.

The switchgear equipment should be placed in an area where clean, dry air is free to circulate around and above it. Since air is taken into the equipment at the bottom of each section and exhausted at the top, a location with good air flow must be provided for efficient operation. A minimum of 30 inches of clear space above the equipment is recommended.

### B. Foundation Requirements

For optimum performance of your General Electric switchgear equipment, the foundation requirements expressed in this section should be strictly adhered to.

**NOTE:** The foundation for the outdoor switchgear must provide proper drainage of ground and/or surface water accumulations away from the equipment.

The foundation must be smooth and level in all planes.

### C. Foundation Preparation

#### C-1. Indoor Equipment

Refer to Fig. 4-1 along with the owner's foundation construction drawings, and the General Electric supplemental installation drawings. Although the indoor switchgear equipment can be mounted directly on a smooth, level floor, it is recommended that recessed steel channels be installed for supporting the equipment. Channel sills, when supplied by the General Electric Company, are 5 inches x 1 $\frac{3}{8}$  inches nominal, with tapped holes for  $\frac{1}{2}$ -13 anchor bolts. The bolts are *not* supplied by General Electric.

**NOTE:** When the equipment is installed on a surface subject to impact (shock) loads due to operating conditions or environmental seismic (earthquake) conditions, the anchor bolts should be fabricated of medium carbon steel (grade 5 load rating).

The tapped holes on channel sills supplied by General Electric, are offset one inch from the center line to allow the sills to extend  $\frac{1}{2}$  inch in front of, and to the rear of, the switchgear equipments. The floor channels under the front and rear switchgear anchor points (see Fig. 4-1) should be embedded in a level concrete slab with their top surfaces flush with the finished floor. It is essential that these steel channels be level and aligned with each other prior to final anchoring, to prevent distortion of the switchgear structure, to assure proper mechanical and electrical connections between shipping splits, and to assure proper interfacing other close-coupled equipments.

AKD-8 Switchgear and Load Center Substations are frequently mounted on steel floors and/or structural steel in industrial installations (such as a mezzanine) to minimize usage of production floor space. Regardless of the type of mounting surface, the requirements for a smooth level surface remain.

# AKD-8 Low-voltage Switchgear

## SECTION IV—Equipment Installation

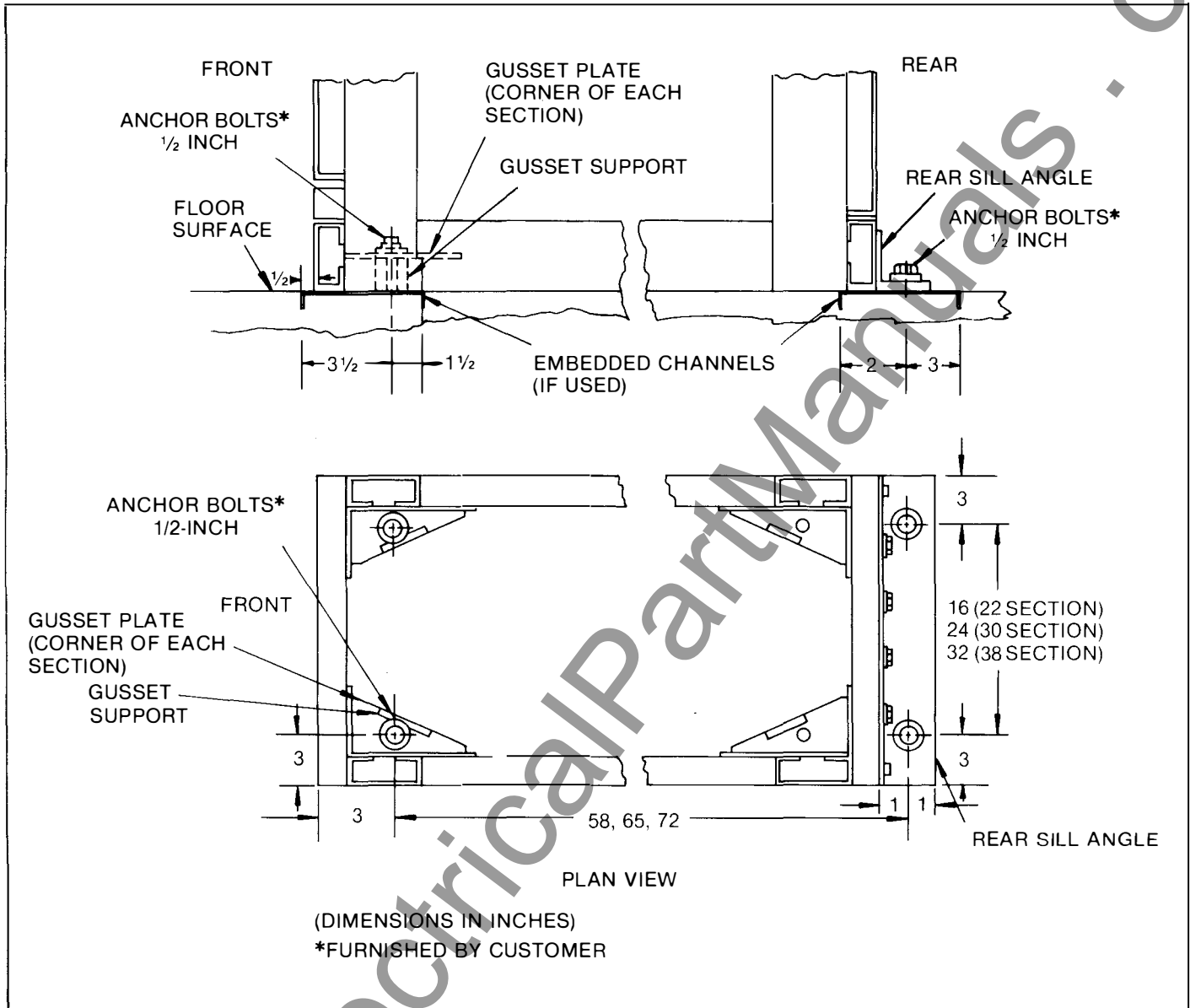

Fig 4-1. Indoor enclosure — location of equipment anchor points

If studs or anchor bolts are to be used, they should be installed in the foundation as it is poured. It is important that the studs or bolts are spaced to agree with dimensions given on the General Electric job drawings. The dimensions between anchor bolts for a particular installation are dependent upon the configuration of equipment ordered. The

dimensions shown on Fig. 4-1 cover all of the standard enclosures available for AKD-8 Switchgear.

Figure 4-2 illustrates the space available for conduit and/or cable entrance through the bottom or top of each equipment section. The space required for control wiring entry to the optional wiring trough is also shown.

# SECTION IV—Equipment Installation

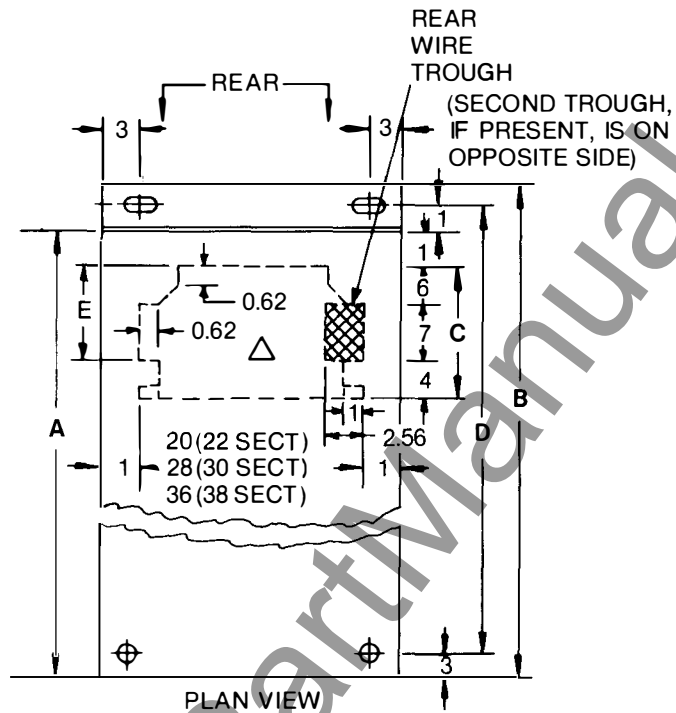

(DIMENSIONS IN INCHES)

△Space available for power cables/conduits is enclosed with broken lines. Cross-hatched area used for optional control wire cable trough (approximately 2-inches wide by 7-inches deep) and may be located on one or both sides of the section.

Section Type	Leads	A	B	C	D	E	Conduit Area Approx. (Sq. Inches)		
							22W	30W	38W
Standard—Nonfused and Fused R/O	Below	60"	62"	17"	58"	13"	340	476	612
	Above			26"			520	728	936
Standard— Integral Fused	Below	67"	69"	17"	65"		340	476	612
	Above			26"			520	728	936
Optional—Deep Non-Fused/Fused R/O	Below	67"	69"	24"	65"	20"	480	672	864
	Above			33"			660	924	1188
Optional—Deep Integral Fused	Below	74"	76"	24"	72"		480	672	864
	Above			33"			660	924	1188
Optional—Extra Deep Non-Fused/Fused R/O	Below	74"	76"	31"	72"	27"	620	868	1116
	Above			40"			800	1120	1440

Fig. 4-2. Bottom cable entry space — indoor AKD-8

# AKD-8 Low-voltage Switchgear

## SECTION IV—Equipment Installation

### C-2. Outdoor Equipment

Refer to Fig. 4-3 along with the owner's foundation construction drawings and the General Electric supplemental installation drawings. The outdoor switchgear equipment is

supplied with three built-in structural support channels in the base of the switchgear as shown in Fig. 4-3. The front and rear structural support channels are designed to be clamped to the foundation. The center channel is a structural stabili-

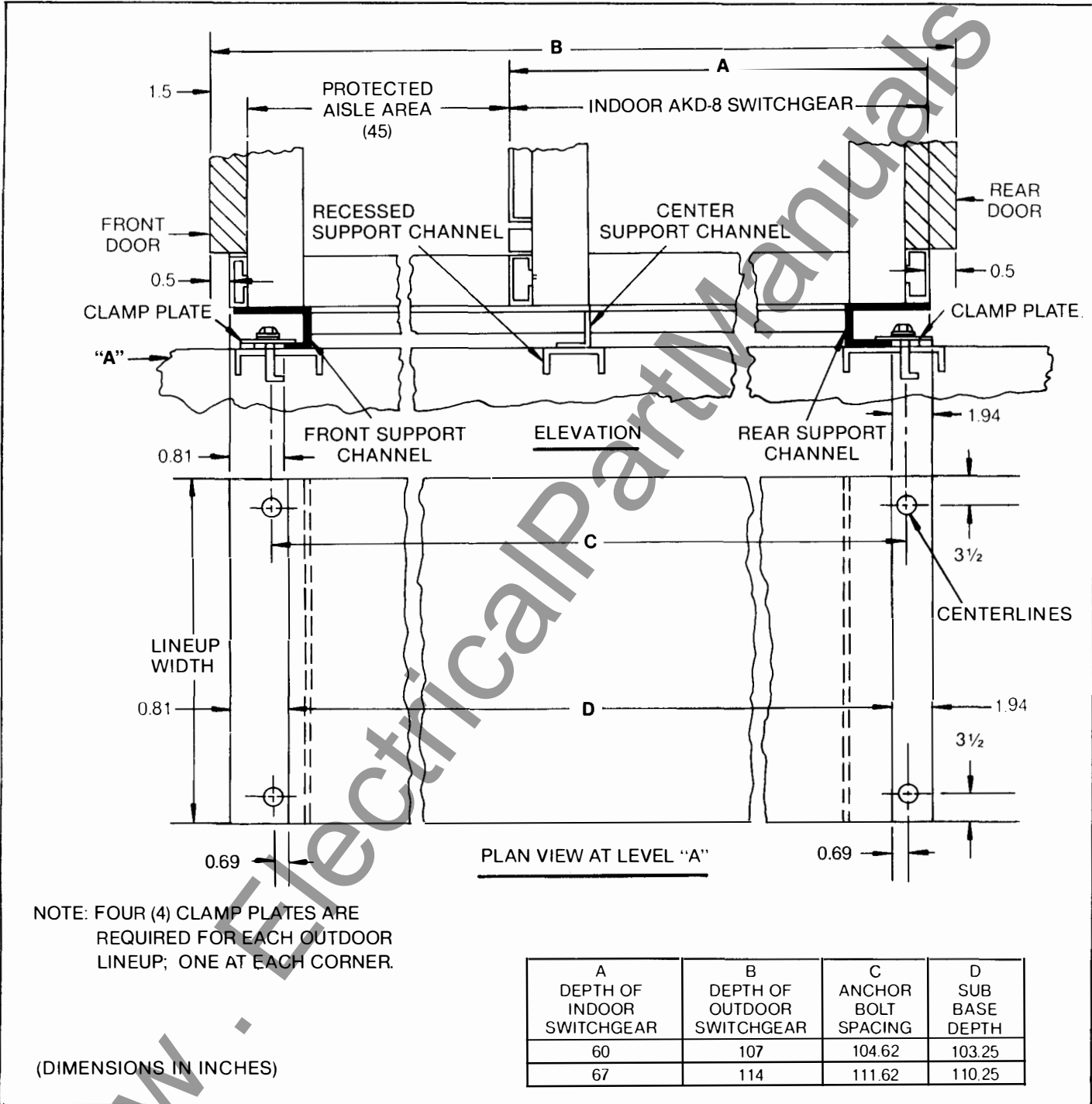

Fig. 4-3. Outdoor enclosure mounting details and anchor bolt location

## SECTION IV—Equipment Installation

zation channel. Although the equipment can be mounted directly on a smooth, level surface, it is recommended that recessed steel channels be installed to support the switchgear. The floor channel sills under the front, center, and rear of the switchgear base should be embedded in a level concrete slab with their top surfaces flush with the finished floor.

While the equipment base center channel is not anchored to the foundation, it is still required that the center channel sill (see Fig. 4-3) be level with the foundation and also with the front and rear channel sills to prevent structural distortion of the switchgear equipment.

Only four anchor bolts are normally used for outdoor enclosures.

**NOTE:** The factory must be consulted for anchoring recommendations for equipments subject to operational and/or environmental (seismic) shock loading.

Anchor bolts and channel are to be provided by the purchaser; the clamp plates (Fig. 4-4) are supplied with the equipment.

It is recommended that the anchor bolts be  $\frac{5}{8}$ -inch diameter.

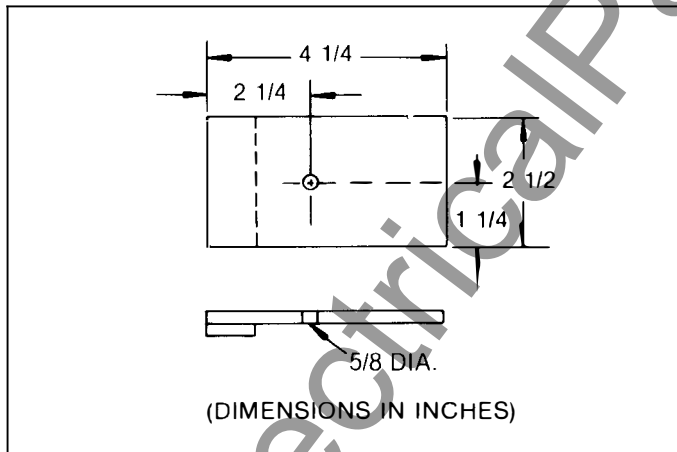

Fig. 4-4. Outdoor enclosure clamp plate

### 4.2—Assembly and Installation of Switchgear Equipment

#### A. General Requirements

Before assembling or installing the switchgear equipment, all components should be available at the site location. This will facilitate switchgear component identification as well as installation. The foundation should be prepared in accordance with the instructions in Sections 4.1 and 4.2, and all embedded conduits installed and capped.

**NOTE:** If rollers are to be used for movement of the equipment to its permanent installation, it is recommended that the shipping skid not be removed until the equipment is placed in position over the anchor bolts.

If a transformer is not part of the installation, and/or the equipment has been split for shipment, place the center section on the foundation first. Assemble the remaining sections outward from the center section, in each direction.

If the switchgear equipment is part of a Load Center Unit Substation, the transformer section should be set on its pad first in accordance with the instructions furnished with the transformer. All remaining sections of the switchgear should then be installed.

**NOTE:** Prior to assembling and installing the switchgear equipment, the foundation must be absolutely level and clear of debris to prevent damage to the switchgear equipment.

#### B. Detailed Assembly and Installation Instructions

##### B-1. Indoor Equipment

The recommended procedure for installation of an indoor switchgear or Load Center Unit Substation is as follows:

1. POSITION THE EQUIPMENT—Position the equipment or sections of the complete equipment in their final location.

**NOTE:** If the equipment line-up was split into shipping sections, the lifting plates on corners of adjacent sections shown in Fig. 4-5 must be removed. Failure to remove these plates will interfere with mating adjacent sections and prevent installation of bus splice plates, structure tie plates, etc.

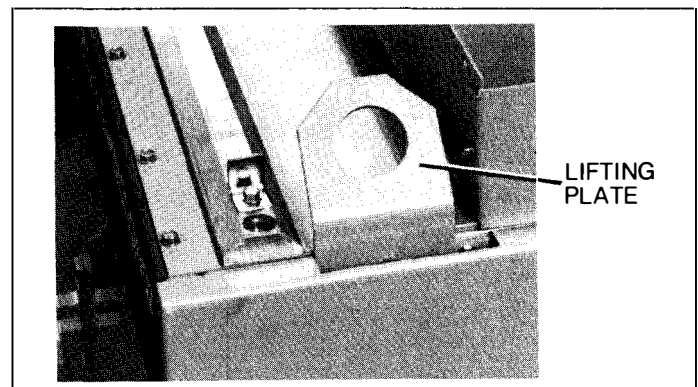

Fig. 4-5. Lifting plate location

# AKD-8 Low-voltage Switchgear

## SECTION IV—Equipment Installation

Once the lifting plates have been removed, they may be discarded.

**NOTE:** In the event the lifting plates must be reassembled on the equipment for lifting purposes, they must be moved to locations where unused screw holes are available, generally achieved by shifting the plate horizontally on the mounting surface one bolt-hole from its previous location. When remounting the lifting plates, torque the mounting bolts to 7-10 ft-lbs.

**NOTE:** All mating sections of the equipment line-up (including transformer, if applicable) must be securely fastened together prior to tightening anchor bolts fastening the equipment to the mounting surface.

2. REMOVE THE SHIPPING SKIDS—The equipment is fastened to the shipping skids with  $\frac{3}{8}$ -3 lag screws through the equipment anchoring holes. See Fig. 4-6.

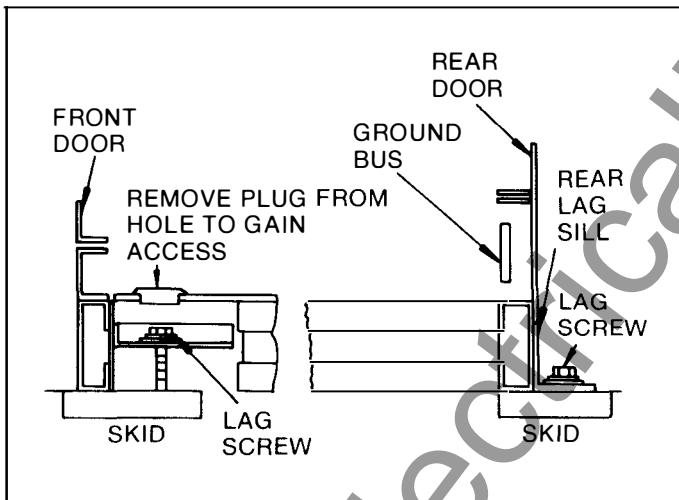

Fig. 4-6. View showing method of attaching equipment to shipping skids

Equipment shipping sections up to 10 feet long will be fastened to the equipment with four lag screws, one in each corner. Longer sections will have two additional lag screws which are located near the middle of the equipment. The shipping skid and lag screws are expendable material and may be disposed of at the purchaser's discretion.

3. FASTEN SECTIONS TOGETHER—After placement of the equipment and installing the anchor bolts loosely, the various shipping sections must be rigidly fastened together. A combination of tie clips and through-bolts fasten each section of the switchgear equipment to the adjacent section. Figure 4-7 shows the location of the tie clips and through-bolts.

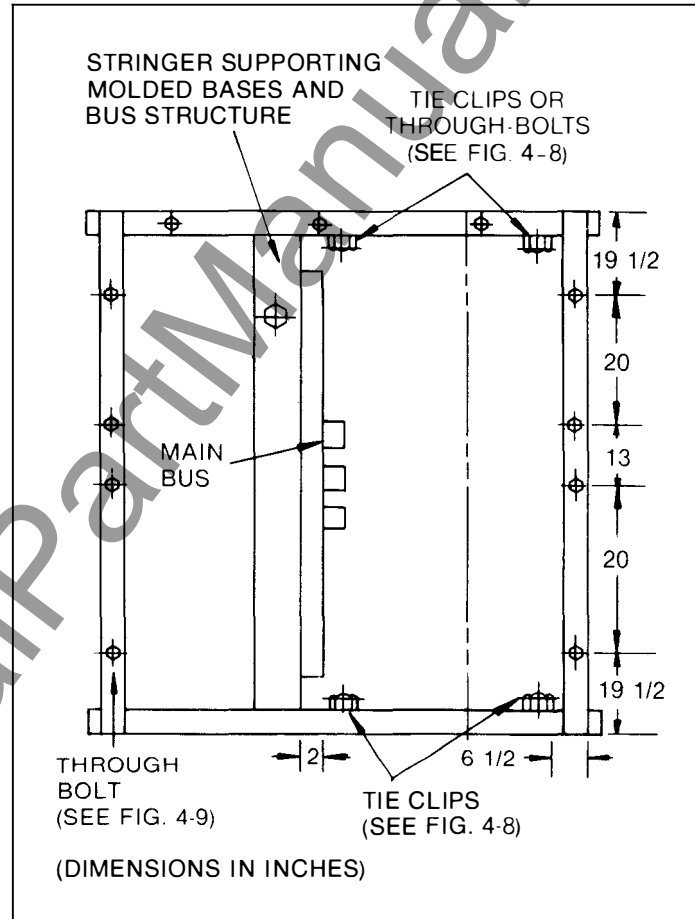

Fig. 4-7. Location of tie-clips

## SECTION IV—Equipment Installation

The four tie clip locations are accessible in the rear bus/cable termination area. Figures 4-8 and 4-9 illustrate the installation of the tie clips and through-bolts. The fasteners for the tie-clips are ¼-20 self-tapping bolts which should be tightened with a torque of nine ft-lbs.

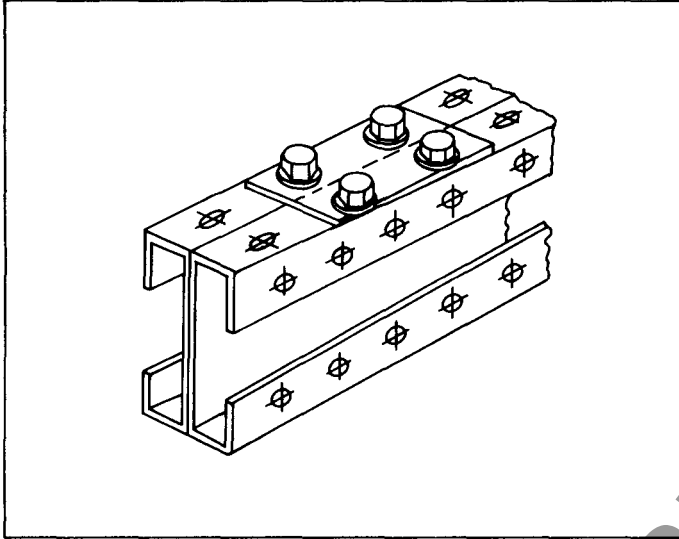

Fig. 4-8. Installation of tie-clips

The through-bolts are in the front and rear compartments. The nut and bolt assembly should be tightened with a torque of 25-30 ft-lbs.

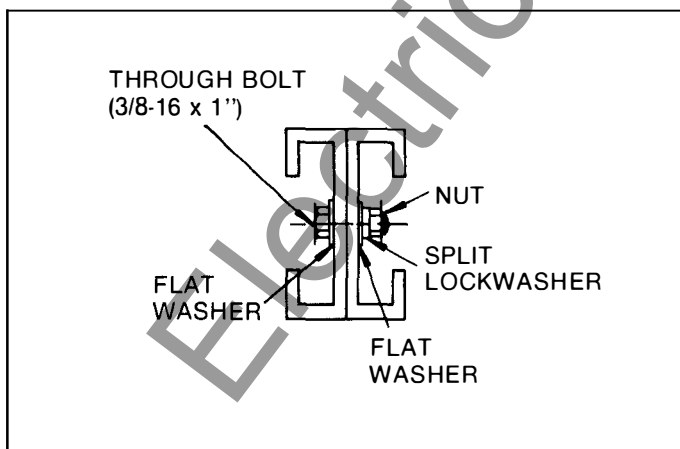

Fig. 4-9. Through-bolt installation

All of the hardware required for assembling the equipment across the shipping splits is furnished with the equipment. If a transformer is included in the line-up of equipment, the transformer flange should be aligned with the opening in the side of the transition compartment and fastened together using the ¾-16 bolts, nuts and washers supplied with switchgear. The fastener assembly should be tightened with a torque of 25-30 ft-lbs.

4. COMPLETE THE ELECTRICAL INTERCONNECTIONS— After completing the mechanical connections between the several sections of equipment, the electrical interconnections should be completed. This includes the installation of splice plates for the main bus bars, the neutral bus, and the ground bus in addition to the control and metering circuits.

**WARNING: ALL SWITCHGEAR EQUIPMENT MUST BE ADEQUATELY GROUNDED FOR SAFETY. FAILURE TO GROUND EQUIPMENT PROPERLY MAY RESULT IN SERIOUS INJURY.**

Figure 4-10 illustrates the general location of the buses that must be spliced across the shipping splits.

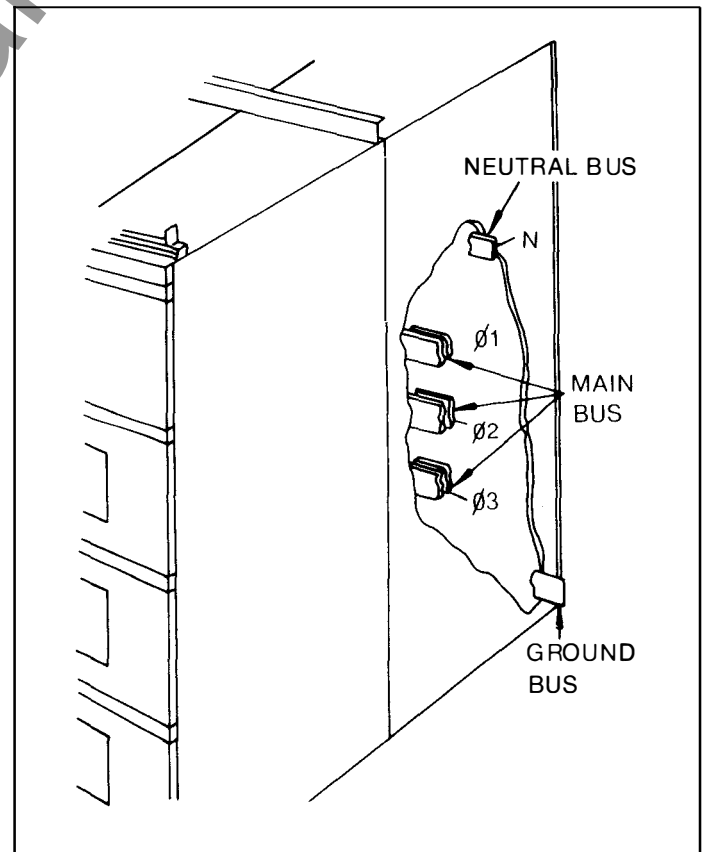

Fig. 4-10. Typical location of buses at shipping split

# AKD-8 Low-voltage Switchgear

## SECTION IV—Equipment Installation

The ground bus is mounted directly on the rear upright channels.

**NOTE:** It is particularly important that the ground bus be connected first since it provides an integral ground for all the equipment. It must also be connected to the station ground prior to proceeding with the installation.

A 4/0 AWG cable connector is located in the bottom of the transition section (or in the incoming line compartment if a transition section is not included) for terminating the purchaser's cable connection to ground. The specific location of the station ground connection is shown on the site floor plan drawing and in the electrical drawings supplied with the equipment. All grounding of the switchgear should be in accordance with National Electrical Code.

**CAUTION:** TO ACHIEVE THE MINIMUM CONTACT RESISTANCE ACROSS A BOLTED BUS JOINT, IT IS RECOMMENDED THAT THE JOINT CONTACT SURFACES BE COATED WITH A FILM OF LUBRICATING GREASE, D50HD35 (formerly D50H47). A TUBE OF THIS GREASE IS SUPPLIED WITH THE EQUIPMENT. DO NOT PUT GREASE ON THE BOLT THREADS AS THIS WILL AFFECT THE CLAMPING FORCE EXERTED BY THE BOLT.

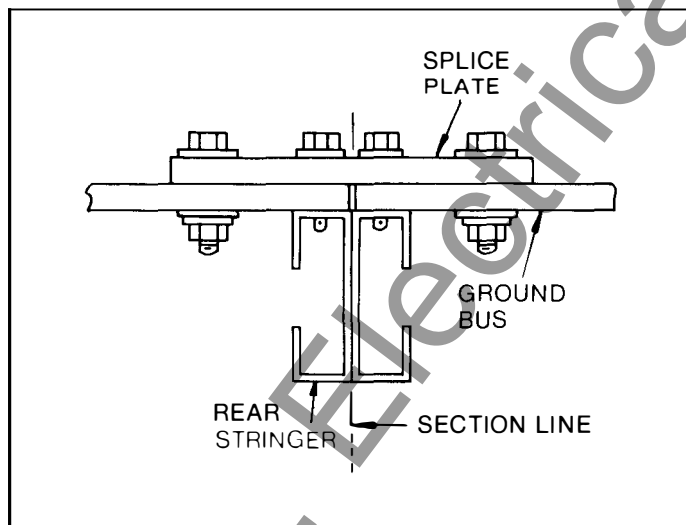

Fig. 4-11. Plan view of ground bus splice

Figure 4-11 illustrates the installation of the ground bus splice plate across a shipping split. In addition to the bolted fastening of the splice plate to the two ends of the ground bus, self-tapping ¼-20 bolts pass through the splice plate and ground bus stubs, and thread into the equipment frame. These bolts should be fastened with a torque of 9 ft-lbs.

If a transformer is present in the line-up, a ground bar located in the transition compartment, Fig. 4-12, is provided for connection of the transformer ground pad to the equipment ground termination point.

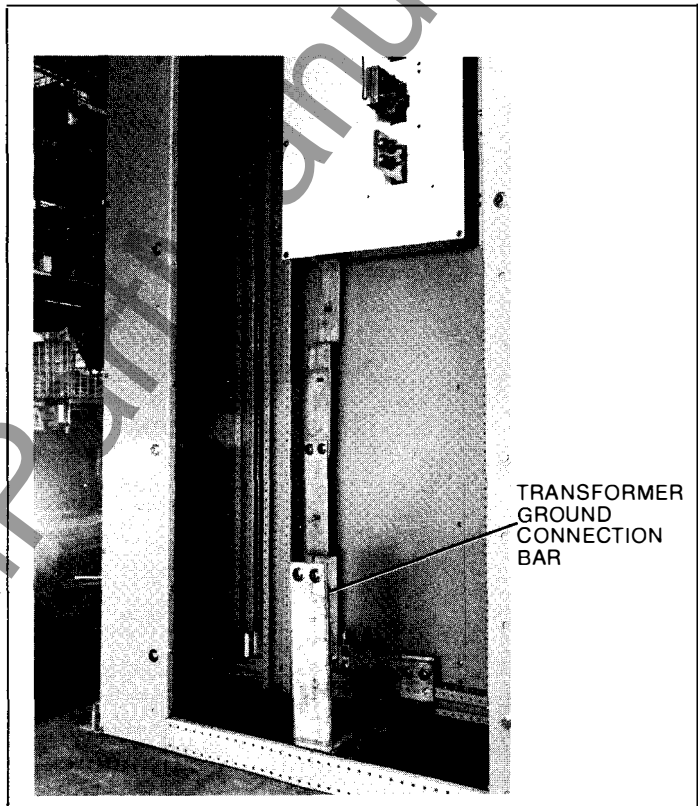

Fig. 4-12. Location of ground bar in transition compartment

As shipped, the ground bar is mounted so it does not protrude beyond the outer surface of the equipment. When the equipment is installed in its final location, the ground bar must be reassembled using the outer bolt holes in the horizontal ground bus spanning the width of the transition compartment. In this mounting location, the offset portion of the ground bar will permit connection to the transformer ground pad with the ½-13 bolt assembly supplied with the switchgear equipment. If an optional floor plate is supplied for the transition compartment, it will be necessary to remove the floor plate to permit relocation of the ground connection bar.

## SECTION IV—Equipment Installation

All bolted bus joints should be made using the proper torque as shown in Table A-1 in Appendix A of this manual.

Transformers not manufactured by General Electric may require special mounting and bus connection hardware.

The neutral bus may be insulated from the grounded frame of the switchgear equipment; thus, it is mounted on insulators throughout the equipment. Installation of the neutral bus splice plate across a shipping split is similar to the ground bar splice *except* that the splice plate is not bolted to the equipment frame. Figure 4-13 illustrates the installation of the neutral splice plate.

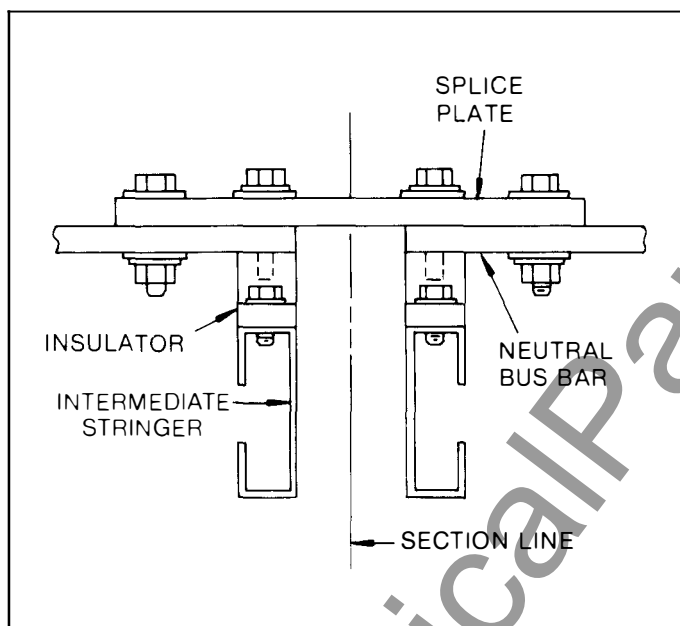

Fig. 4-13. Plan view of neutral bus splice installation

**CAUTION:** TO ACHIEVE THE MINIMUM CONTACT RESISTANCE ACROSS A BOLTED BUS JOINT, IT IS RECOMMENDED THAT THE JOINT CONTACT SURFACES BE COATED WITH A FILM OF LUBRICATING GREASE, D50HD35 (formerly D50H47). A TUBE OF THIS GREASE IS SUPPLIED WITH THE EQUIPMENT. DO NOT PUT GREASE ON THE BOLT THREADS AS THIS WILL AFFECT THE CLAMPING FORCE EXERTED BY THE BOLT.

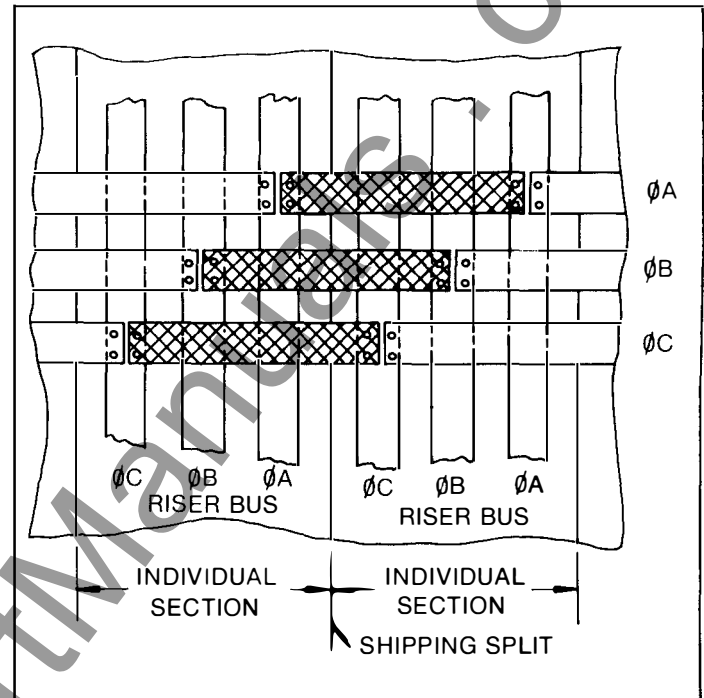

Fig. 4-14. Installation of main bus splice plate on copper bus system

The installation of the horizontal bus splice bars is intended to be accomplished with bolted joints whether the bus bars are fabricated of either copper or aluminum material. If the purchaser requires a welded joining of splice bars on an aluminum bus system, it may be achieved provided installation personnel have the skill and equipment to perform MIG welding.

Figures 4-14 and 4-15 illustrate the assembly of the main bus splice plates on a bolted copper bus system.

Figure 4-14 shows the rear view of the main bus area with the installed splice plates indicated with cross-hatching. Figure 4-15 shows that a spacer is used between bus bars when more than one bar is used per phase (normally the 2500-ampere and larger main bus ratings).

# AKD-8 Low-voltage Switchgear

## SECTION IV—Equipment Installation

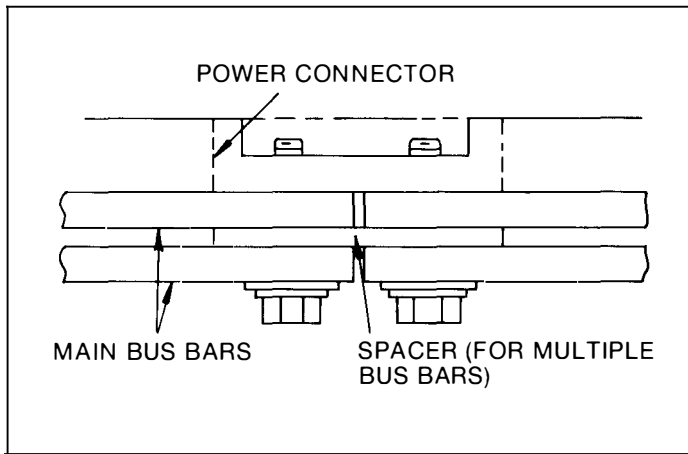

Fig. 4-15. Plan view of main bus splice plate on copper bus system

After assembly of the splice bar, the ½-13 bolts should be tightened to a torque of 35-40 ft-lbs.

Figures 4-16 and 4-17 illustrate the assembly and installation of the main bus splice plates on an aluminum bus system. Figure 4-16 is a rear view of the main bus area with the installed aluminum splice plates indicated by cross-hatching.

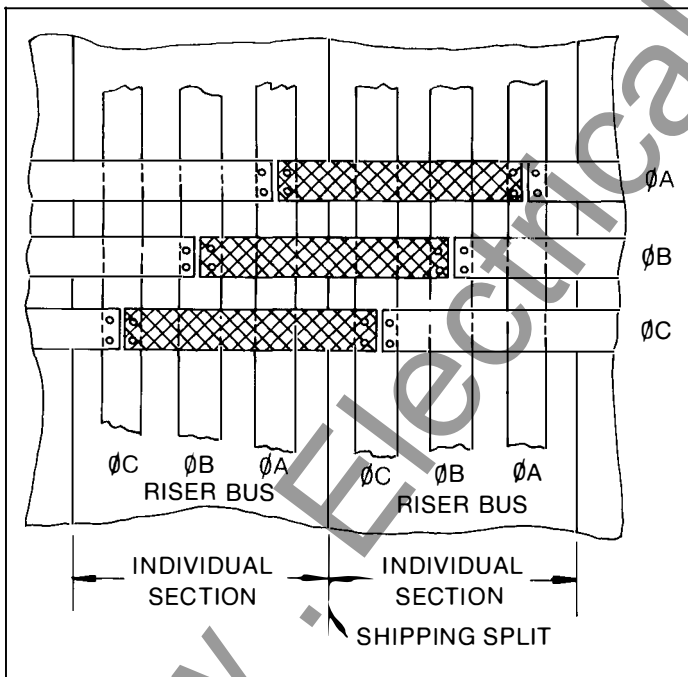

Fig. 4-16. Installation of main bus splice plate on aluminum bus system

The equipment has been designed for installation of the main bus bar splice plates with a bolted joint. In this case, the installation of the splice plate is similar to the procedure previously described for a copper bus joint. The primary difference is the use of a Belleville spring washer on the connection bolts and the different shape of the mounting surface on the power connector.

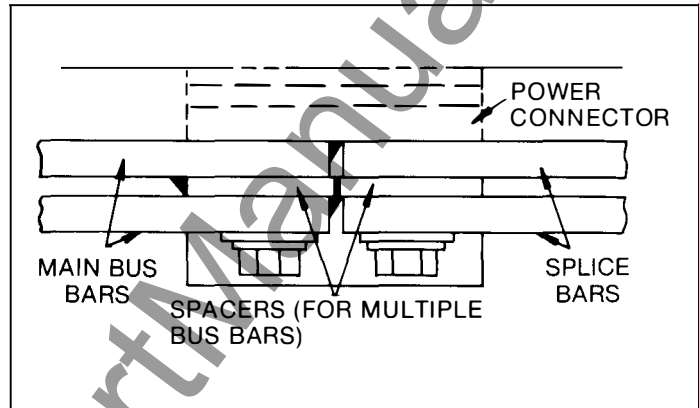

Fig. 4-17. Plan view of main bus splice plate on aluminum bus system

**CAUTION:** TO ACHIEVE THE MINIMUM CONTACT RESISTANCE ACROSS A BOLTED BUS JOINT, IT IS RECOMMENDED THAT THE JOINT CONTACT SURFACES BE COATED WITH A FILM OF LUBRICATING GREASE, D50HD35 (formerly D50H47). A TUBE OF THIS GREASE IS SUPPLIED WITH THE EQUIPMENT. DO NOT PUT GREASE ON THE BOLT THREADS AS THIS WILL AFFECT THE CLAMPING FORCE EXERTED BY THE BOLT.

The recommended torque for tightening the ½-13 bolts connecting the splice plates to the main bus bars and power connector is 35-40 ft-lbs.

Figure 4-17 illustrates a splice joint when multiple horizontal bus bars are used per phase on aluminum bus systems rated above 2000 amperes. If the bus system is rated 2000 amperes or less, only a single main bus bar is used for each phase and thus the spacers are not required at the joint.

## SECTION IV—Equipment Installation

After assembly of the splice bar, the ½-13 bolts should be tightened to a torque of 35-40 ft-lbs.

**NOTE:** Splice bars are designed to be bolted in place. In an aluminum bus system, it is possible to weld splice bars. Do not attempt to do this without contacting the factory for detailed instructions.

After completing the installation of the main bus splice bars, the joint covers may be mounted and secured by the sliding spring clips if the Insul-Bar bus insulation system has been supplied with the equipment.

5. CONNECT THE TRANSFORMER SECONDARY—The connection of the transformer secondary to the incoming bus bars in the transition is made using the flexible connection straps supplied with the transformer. These connections are always bolted joints. There is no provision for a welded joint on equipments supplied with aluminum bus bars.

**CAUTION:** TO ACHIEVE THE MINIMUM CONTACT RESISTANCE ACROSS A BOLTED BUS JOINT, IT IS RECOMMENDED THAT THE JOINT CONTACT SURFACES BE COATED WITH A FILM OF LUBRICATING GREASE, D50HD35 (formerly D50H47). A TUBE OF THIS GREASE IS SUPPLIED WITH THE EQUIPMENT. DO NOT PUT GREASE ON THE BOLT THREADS AS THIS WILL AFFECT THE CLAMPING FORCE EXERTED BY THE BOLT.

The recommended torque for tightening the ½-13 bolts fastening the transformer connection straps to the incoming bus bars is 35-40 ft-lbs.

6. INTERCONNECT CONTROL WIRING—Interconnection of control wiring across shipping splits is accomplished by connecting to terminal blocks located in the cross-section wiring trough on top of the equipment shown in Fig. 4-18.

If terminal blocks are provided, each wire must be attached to the correct point on the terminal block, following the circuit identification number attached to each wire.

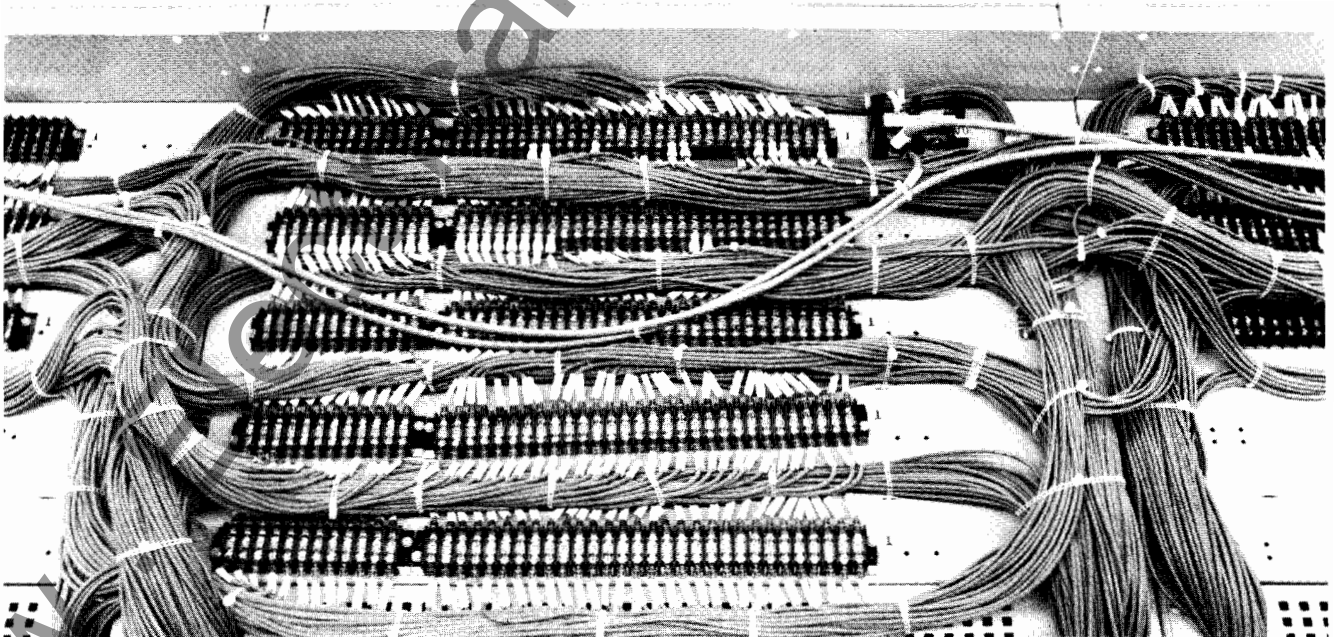

Fig. 4-18. Control wiring is located in the wiring trough on top of the equipment

# AKD-8 Low-voltage Switchgear

## SECTION IV—Equipment Installation

### B-2. Outdoor Equipment

The recommended procedure for installing a switchgear equipment supplied in an outdoor enclosure is as follows:

1. POSITION THE EQUIPMENT—Position the equipment or sections of equipment in their final location. If the equipment line-up was split into two or more shipping sections, it is necessary to first match, line up, and reassemble the multiple sections into one integrated equipment.

2. HOLD GASKET IN PLACE—After removal of the lifting plates (see Fig. 4-5), it is necessary to cement a gasket (6), Fig. 4-19, to the mounting surface of the roof flange (5). The gasket material and cement (3M No. EC870) are supplied with the equipment. Apply a coat of cement to one side of each gasket and position it on one side of the joint.

**NOTE:** The cement is not for sealing the joint. Its sole purpose is to hold the gasket in place.

3. ALIGN SECTIONS—Align the two sections with the mating surfaces butted together.

4. FASTEN SECTIONS TOGETHER—Referring to Fig. 4-19, the mating sections of the outdoor enclosure should be immediately bolted together including the front (3) and rear (4) vertical posts and the roof flange (5). Each vertical post will require ten  $\frac{3}{8}$ -16 NC x 1-inch bolt assemblies; the roof flange will require either eleven or twelve  $\frac{3}{8}$ -16 NC x  $\frac{1}{2}$ -inch bolt assemblies. The bolts should be tightened with a torque of 25 ft-lbs. Figure 4-20 is a cross-sectional view of the assembled roof joint.

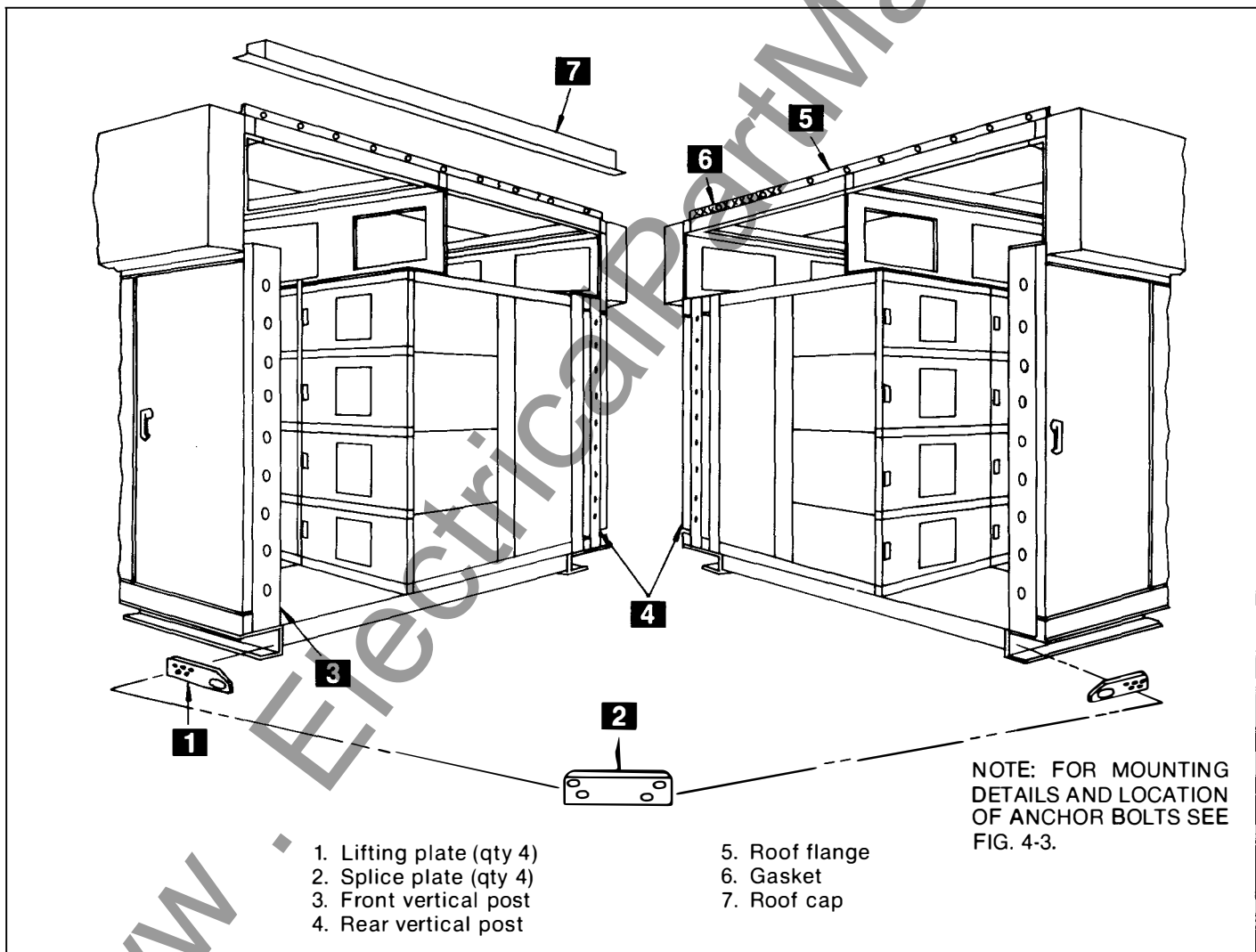

Fig. 4-19. Outdoor enclosure shipping split assembly

## SECTION IV—Equipment Installation

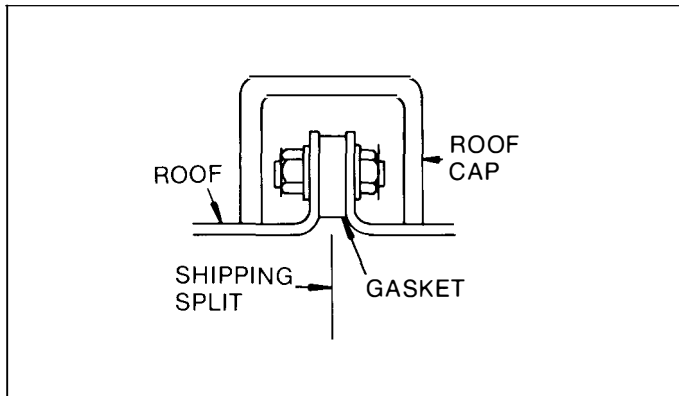

Fig. 4-20. Cross-section view of assembled roof joint

5. TIE HOUSING BASES TOGETHER—Referring to Fig. 4-19, tie the bases of the outdoor housing together using the splice plate (2) supplied with the equipment and the bolts which previously secured the lifting plates (1) removed after emplacement of the equipment. The nuts are welded to the rear surface of the base. The bolts should be tightened with a torque of 45 ft-lbs.

**NOTE:** There are two splice plates required, front and rear of the assembly.

6. INSTALL THE ROOFCAP—The roofcap (7), Fig. 4-19, should be installed over the sealed and fastened roof flange assembly (5). The roof cap is secured in place with two ¼-20 NC x ½-inch thread forming bolts, each at the front and the rear ends of the roof cap. These bolts should be tightened with a torque of nine ft-lbs.

7. CONNECT TRANSFORMER FLANGE—If a transformer is included in the equipment line-up, the flange should be connected to the switchgear opening using the gasket material, cement, and fastening material supplied with the switchgear equipment.

8. JOIN SECTIONS TOGETHER—The switchgear equipment within the outdoor enclosure should be joined to its mating sections in the manner described for indoor equipment in Section 4.2, Paragraph B-1, Step 3, Page 40.

9. MAKE ELECTRICAL INTERCONNECTIONS—The installation of bus splice plates for the main horizontal, neutral and ground buses should be done in accordance with the instructions for indoor equipment, Section 4.2, Paragraph B-1, Step 4, Page 41.

10. CONNECT THE TRANSFORMER SECONDARY—The installation of the transformer connection straps to the incoming bus should be done in accordance with the instructions for indoor equipment, Section 4.2, Paragraph B-1, Step 5, Page 45.

11. INTERCONNECT CONTROL WIRING—The interconnection of control wiring across shipping splits should be done in accordance with the instructions for indoor equipment, Section 4.2, Paragraph B-1, Step 6, Page 45.

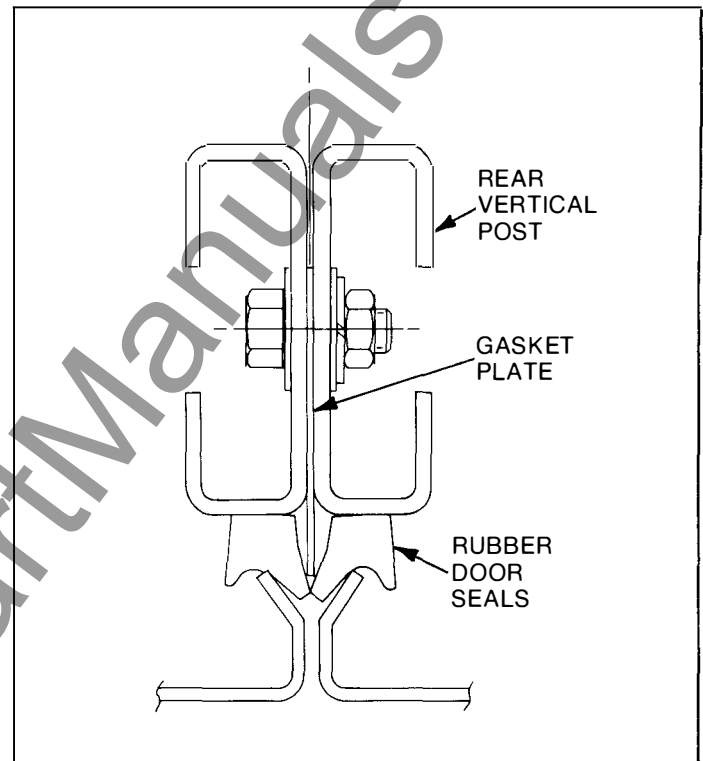

Fig. 4-21. Installation of door seals

12. INSTALL DOOR SEALS—The shipping split assembly is completed by installation of the seals for the front and rear doors. Refer to Fig. 4-21. The rubber door seals should be secured with cement (3M No. EC870) to the front and rear vertical posts. The gasket plate extends out from the enclosure to stiffen and maintain the seals in their proper position against the doors.

13. SEAL SMALL OPENINGS—After completion of the shipping split assembly, any small openings should be sealed with GE Clear Silicone Caulking Cement.

### C. Anchoring Switchgear Equipment

Correct anchoring of the switchgear equipment to the foundation is very important. After completion of reassembly of the equipment at the shipping splits, the equipment anchoring procedure should be completed.

# AKD-8 Low-voltage Switchgear

## SECTION IV—Equipment Installation

### C-1. Indoor Equipment

1. ANCHORING BY ANCHOR BOLTS—Indoor equipments are normally secured to their final mounting surface by anchor bolts threaded into the embedded channel sills. The bolts were loosely threaded into place before reassembling the equipment shipping splits and connecting to the close-coupled transformer, if appropriate.

The anchor bolts should now be tightened with a torque of 35-40 ft-lbs.

2. ANCHORING BY WELD—An alternate method of anchoring the equipment to its foundation is to weld the equipment to floor sills (or the floor itself if constructed of steel). Several methods, shown on Fig. 4-22, are available to the purchaser for welding the equipment to the channel sills.

- a. *The front of the equipment is attached to the embedded channel sills (1), Fig. 4-22, by two  $\frac{3}{16}$ -inch fillet welds (2). It is recommended that two welds, each 2½ inches long (min.), be used for each section to firmly tie the bottom width post (3) to the channel sill.*
- b. *The rear of the equipment may be anchored by one of three procedures:*
  - *The first method is by plug welds (4), Fig. 4-22, using the anchor bolt holes in the rear sill angle (5). The plug weld should receive a minimum ¼-inch bead around the entire circumference of the anchor bolt hole.*
  - *A second method of securing the rear sill angle (5) to the channel sill (1) is the use of two linear fillet welds (2) for each section. It is recommended that each weld be 2½ inches long (min.) with a  $\frac{3}{16}$ -inch fillet (min.).*

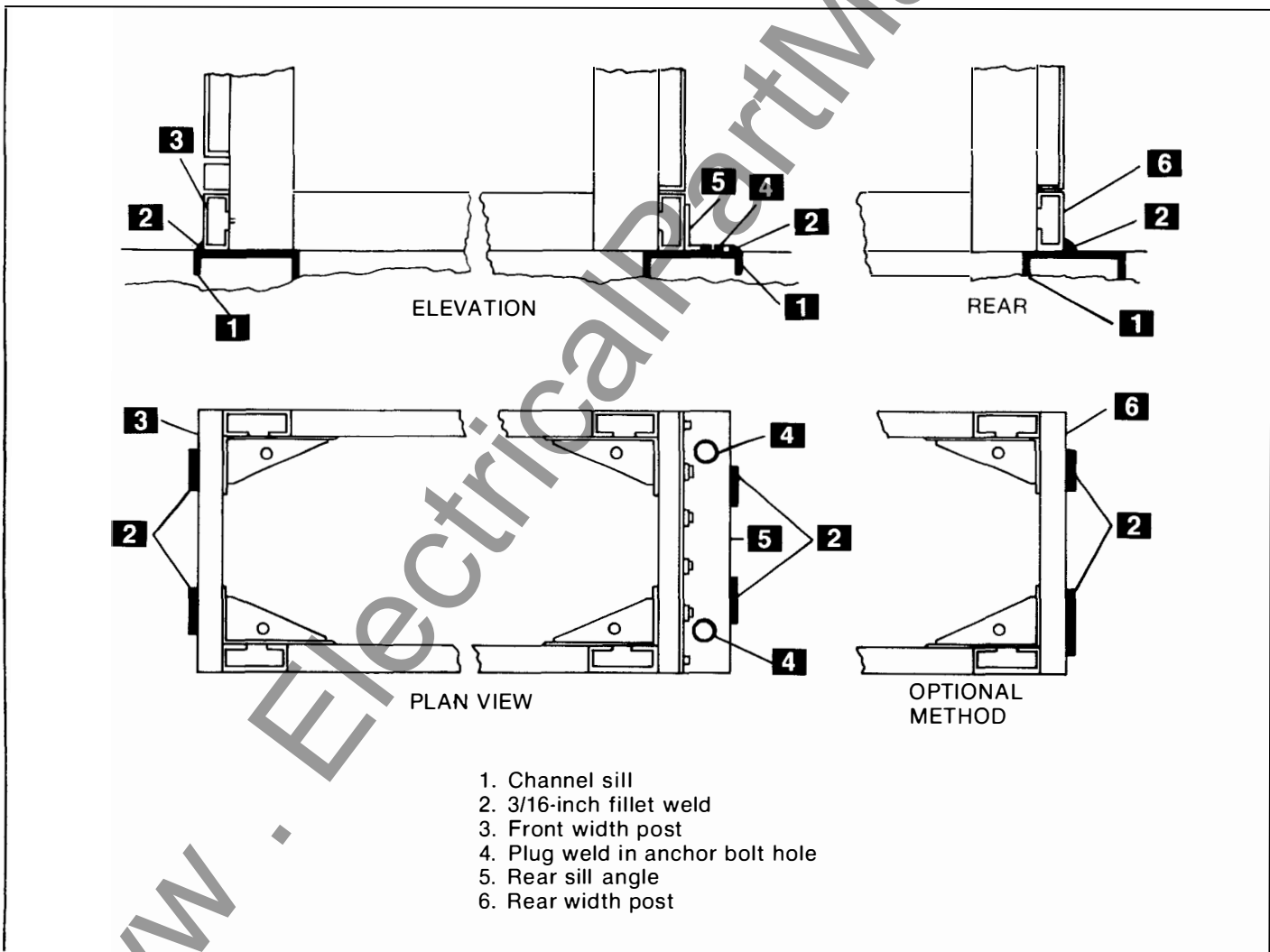

Fig. 4-22. Indoor equipment weld anchoring

# SECTION IV—Equipment Installation

- A third method for anchoring the rear of the equipment is to remove the rear sill angle (5) from the switchgear and weld the rear bottom width post (6) to the channel sill (1). These welds (2) should, like the front welds, have a  $\frac{3}{16}$ -inch (min.) fillet and each have a minimum length of  $2\frac{1}{2}$  inches.

## C-2. Outdoor Equipment

Outdoor equipments are anchored after reassembly of the separately shipped sections. The four anchor bolts should be tightened with a torque of 45 ft-lbs.

**CAUTION:** IF THE EQUIPMENT IS TO BE SUBJECTED TO OPERATIONAL OR ENVIRONMENTAL (SEISMIC) SHOCK LOADING, THE FACTORY MUST BE CONSULTED FOR ANCHORING RECOMMENDATIONS.

## D. Busway Connections

Busway runs must be aligned with openings in the equipment and connected to the mating components electrically and mechanically. A collar is mounted on the top of the equipment cable compartment to which is bolted the busway housing. See Fig. 4-23. The  $\frac{1}{4}$ -20 NC bolts, washers, and nuts for this mechanical connection are supplied with the

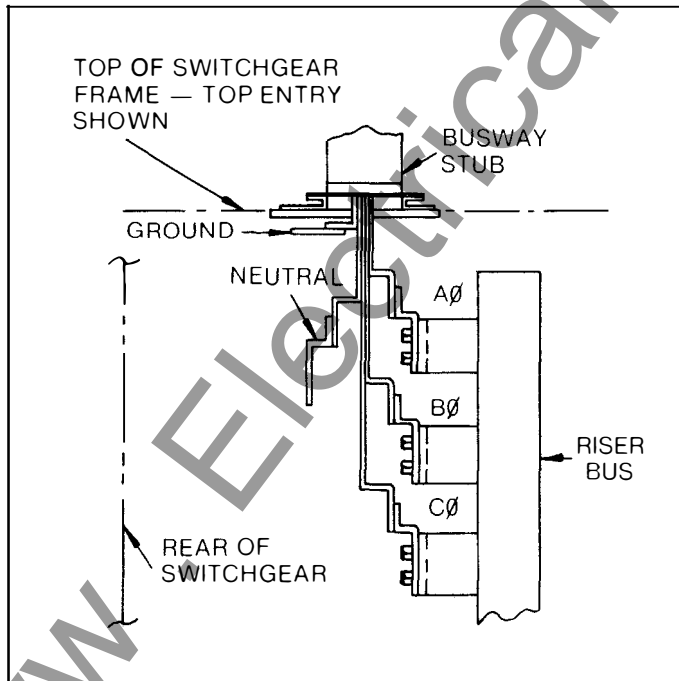

4-23. Armor-clad busway mounting (front-entry)

busway stub. The bolts should be tightened with a torque of nine ft-lbs.

The power conductors in the busway stub are designed to bolt directly to power connector blocks mounted on the switchgear riser bus bars. These connections are made with  $\frac{1}{2}$ -13 NC bolts supplied with the switchgear equipment.

**CAUTION:** TO ACHIEVE THE MINIMUM CONTACT RESISTANCE ACROSS A BOLTED BUS JOINT, IT IS RECOMMENDED THAT THE JOINT CONTACT SURFACES BE COATED WITH A FILM OF LUBRICATING GREASE, D50HD35 (formerly D50H47). A TUBE OF THIS GREASE IS SUPPLIED WITH THE EQUIPMENT. DO NOT PUT GREASE ON THE BOLT THREADS AS THIS WILL AFFECT THE CLAMPING FORCE EXERTED BY THE BOLT.

The recommended torque for tightening the  $\frac{1}{2}$ -13 NC bolts connected the busway stub conduction to the riser bus power connectors is 35 -40 ft-lbs.

## E. Control Wire Connections

For external control wiring, refer to Fig. 4-24 for switchgear cable area dimensions, and connect the control wires to the switchgear section as follows:

1. When control conduits enter the switchgear from below, they should not extend more than one inch above the

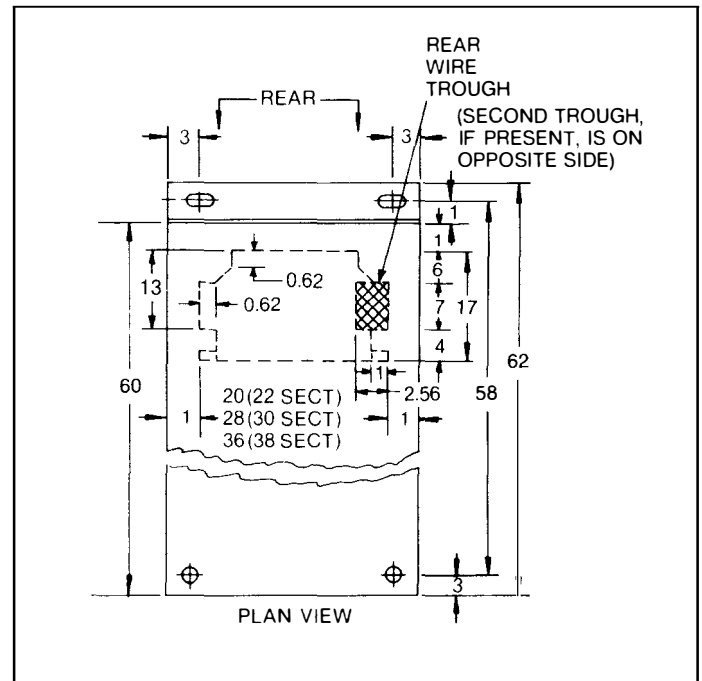

Fig. 4-24. Bottom cable entry space — indoor AKD-8 (60-inches deep)

# AKD-8 Low-voltage Switchgear

## SECTION IV—Equipment Installation

floor. The control wires may be pulled through the conduits before or after the switchgear is installed.

2. Route the control wires from the conduits through the wiring trough (cross-hatched area—2" x 7"—shown on Fig. 4-24) at the side of the cable compartment. Connect the cables to the terminal blocks in accordance with the connection diagrams for the equipment.

3. If the control conduits enter from above, drill the top cover within the available space indicated. See Fig. 4-24. Control wires should be routed to the wiring trough and connected to the terminal blocks as described previously.

### F. Power Cable Connections

Connect the main cables to the main lugs. Before any main cable connections are made, the cables should be identified to indicate their phase relationship with the equipment. Adequate electrical and mechanical clearances must be provided between conduit, cables, and bus. Where the cables enter the section, they can be lashed to optional cable supports at the rear of the cable compartment as required. (See Fig. 3-22.)

Mechanical cable terminals are normally included with the switchgear (compression terminals are supplied when ordered) and are mounted at the ends of the breaker runbacks in the cable compartment. Carefully follow the cable manufacturer's recommendations for installation of cable.

Install the cables in the proper path to the terminals, using temporary lashing if required. Cut the cables to the proper length. Strip the insulation to the desired dimension, being careful not to damage any strands.

For copper cables, coat the wires with D50H47 non-oxidizing grease, insert the cables into the terminals, and tighten the set screws in accordance with torque values shown in the torque value table for cable terminals in the addendum of this manual. See Appendix A, Table A-1.

**CAUTION:** THE TORQUE VALUES SHOWN IN THE TABLE ARE FOR DRY THREADS ONLY. DO NOT GREASE OR OTHERWISE LUBRICATE THE THREADS ON THE CABLE TERMINALS AS THIS WILL PERMIT OVERTIGHTENING OF THE SCREW AND CAUSE POSSIBLE DAMAGE TO THE TERMINAL OR CABLE.

For aluminum cables, wire brush the wire strands thoroughly. Immediately after wire brushing, coat the cable strands with a quality oxide inhibiting compound such as Penetrox A. Insert exposed wires into the terminals and tighten the set screws in accordance with values shown in the torque Table A-3 in Appendix A of this Instruction Book.

**CAUTION:** THE TORQUE VALUES SHOWN IN THE TABLE ARE FOR DRY THREADS ONLY. DO NOT GREASE OR OTHERWISE LUBRICATE THE THREADS ON THE CABLE TERMINALS AS THIS WILL PERMIT OVERTIGHTENING OF THE SCREW AND POSSIBLE DAMAGE TO THE TERMINAL OR CABLE.

This should result in the oozing of compound material from between individual strands. Wipe off any excess compound.

Bolt the cable terminal connectors to the ends of the bars in the cable compartment. A non-oxidizing grease, such as D50H47 furnished with each equipment, should be used at these connection surfaces. The bolts should be tightened with a torque of 35 ft-lbs.

Lash the cables securely to the cable support, if present, to take their weight off the runbacks and to brace them against short circuit forces in the event of a fault.

### G. Relays and Control Devices

Remove all blocking on relays and devices as shown in the instructions accompanying the devices.

## SECTION IV—Equipment Installation

### H. Breaker Hoist

#### H-1. Indoor Equipment

Figure 4-25 shows the breaker hoist assembled on an indoor switchgear equipment. When supplied with indoor equipment, the hoist is shipped in a separate carton completely assembled, Fig. 4-26.

Before attempting to install the hoist assembly on the switchgear equipment, it is necessary to remove the runner guide from the hoist carriage as shown in Fig. 4-27. Do not dispose of this guide since it must be reinstalled after mounting the hoist on the equipment.

**NOTE:** Maximum recommended lifting capacity is 700 lbs.

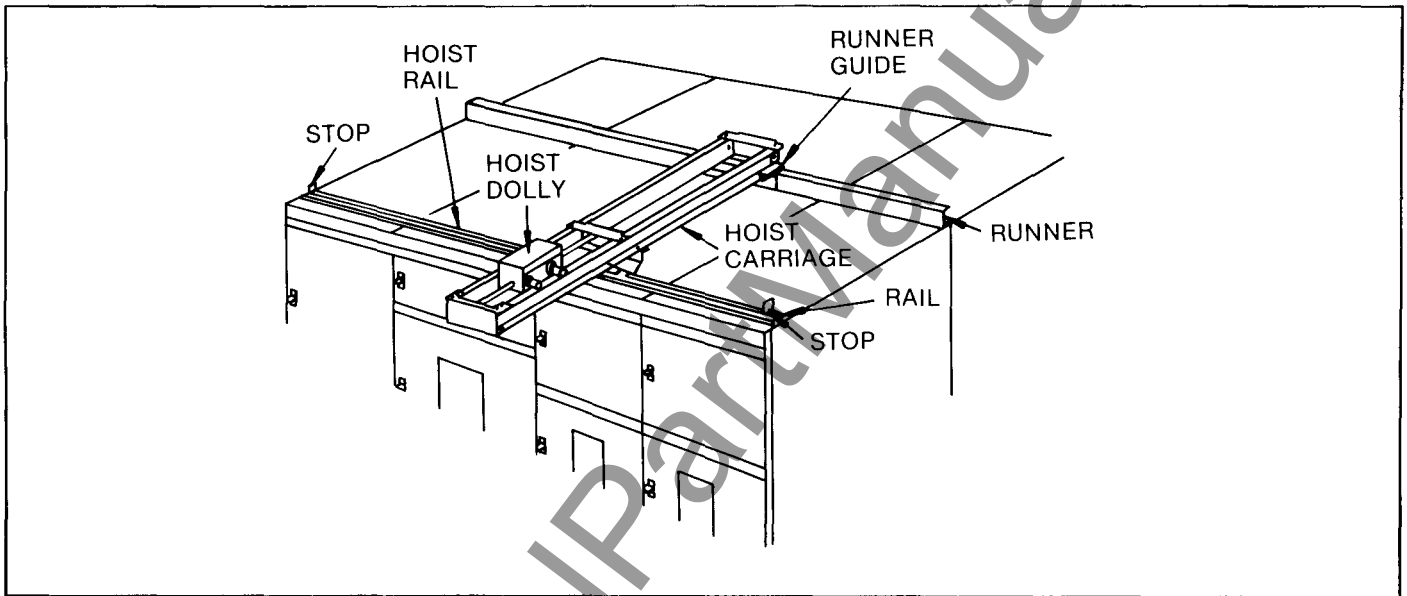

Fig. 4-25. Breaker hoist assembly on indoor switchgear

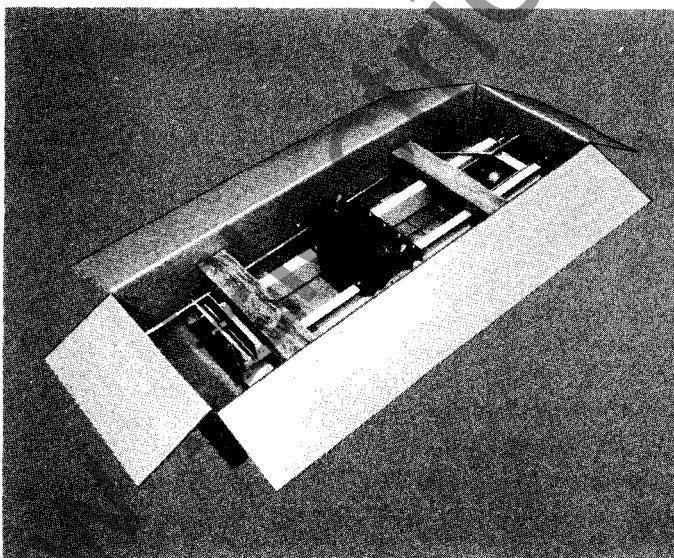

Fig. 4-26. Carton containing breaker lifting device

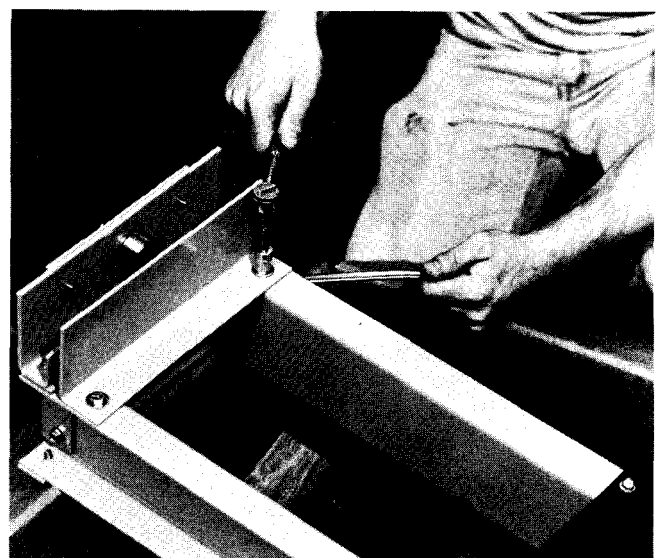

Fig. 4-27. Removal of hoist runner guide

# AKD-8 Low-voltage Switchgear

## SECTION IV—Equipment Installation

The hoist should be lifted into position on top of the switchgear so that the end with the single roller is toward the rear of the equipment, Fig. 4-28.

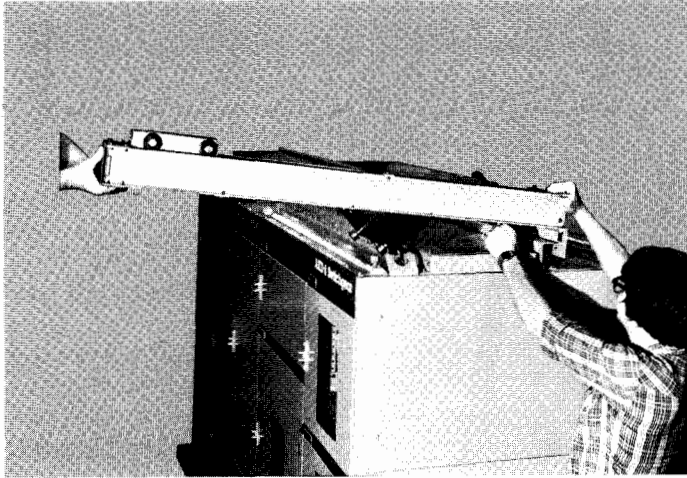

Fig. 4-28. Positioning of hoist on top of switchgear

The rear wheel can then be hooked under the channel and the front wheels can be positioned on the front track. See Fig. 4-29. The retaining angle at the rear should then be reassembled. Stop clips are provided at each end of the front track to prevent the hoist from rolling off the ends of the track.

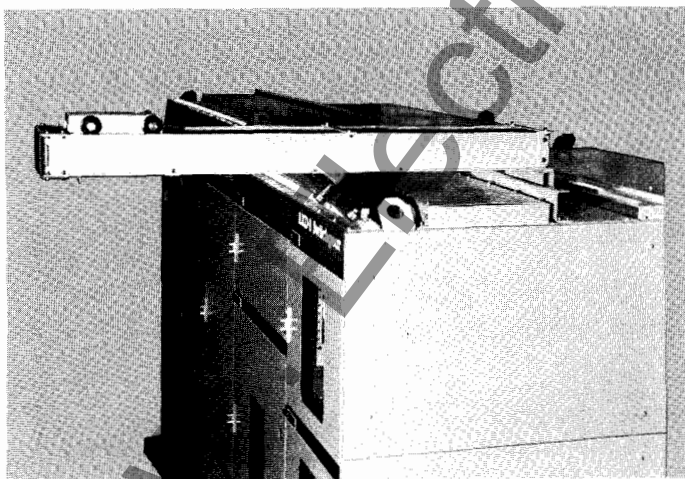

Fig. 4-29. Rear wheel hooked under channel and front wheels on front track

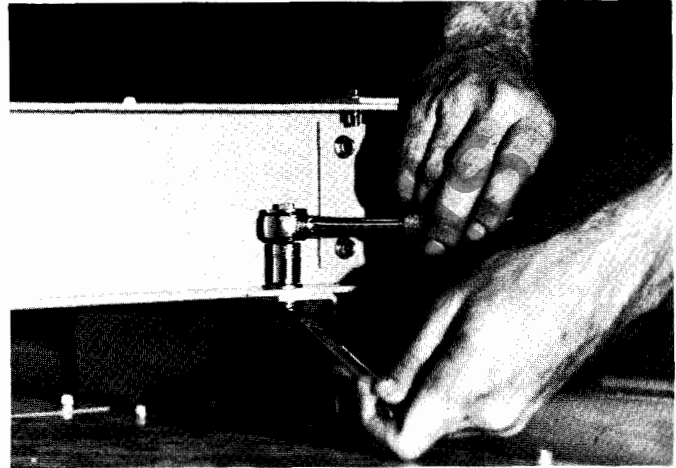

Fig. 4-30. Replacing the runner after completion of hoist installation

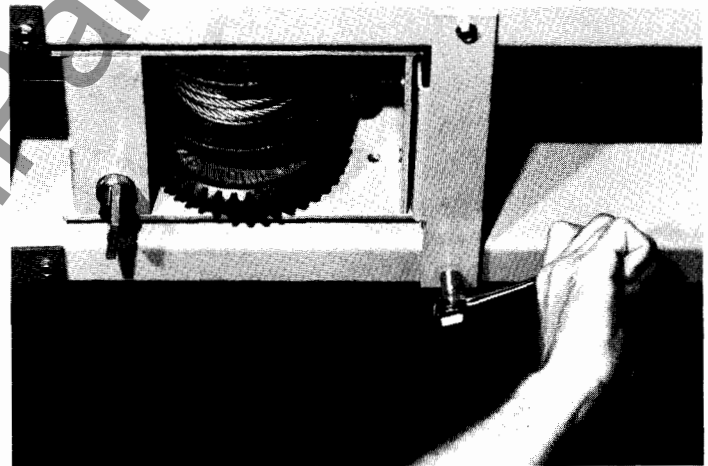

Fig. 4-31. Removing the bracket locking the hoist dolly

After completion of the hoist installation, replace the runner guide, Fig. 4-30, and remove the bracket, Fig. 4-31, locking the hoist dolly on the carriage.

If the equipment has been shipped in sections, run the hoist carriage over the assembled shipping split to check the alignment of the hoist rail and runner. If necessary, adjust the rail and/or runner for smooth operation of the rollers on the hoist carriage.

## SECTION IV—Equipment Installation

### H-2. Outdoor Equipment

When the hoist is provided with outdoor equipment, it is shipped mounted and secured in place. The shipping supports at either end of the hoist movable track must be removed. To free the hoist dolly, remove the retaining clip used to keep it in place during shipment, as shown in Fig. 4-32.

### I. Final Inspection

Make a final inspection to see that no tools, construction materials, or other foreign matter have been left in the switchgear equipment.

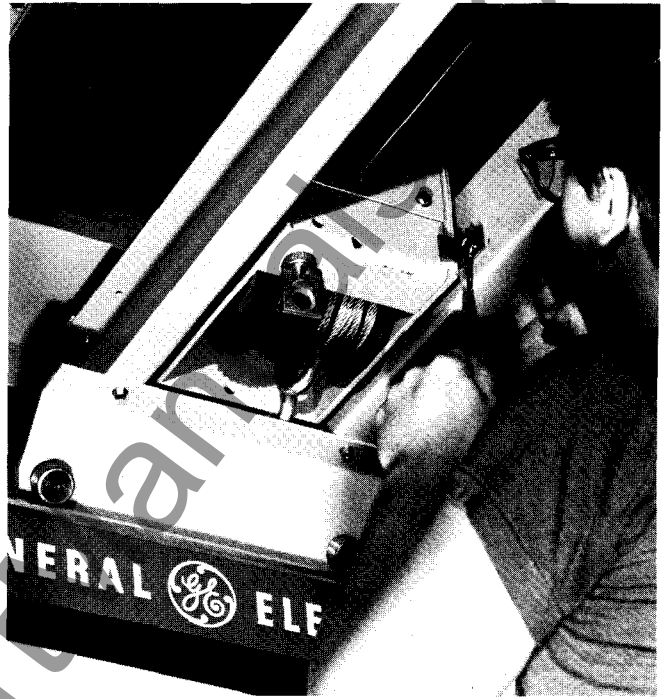

Fig. 4-32. Removing retaining clip to free hoist dolly

# AKD-8 Low-voltage Switchgear

## SECTION V—Installing and Removing Circuit Breakers

### 5.1—General

#### A. Inspection and Preparation of Circuit Breakers

Before installing, operating, or removing a circuit breaker, refer to the breaker instruction manual for preparation, inspection, and test. Check thoroughly for damaged or loose parts and for any dirt or foreign matter which may be in the breaker. Be sure that a thin film of D50H47 grease is present on primary disconnects of the switchgear before installing the breaker.

#### B. Circuit Breaker Installation

To install a circuit breaker, proceed as follows:

1. Before installing a breaker, check the tightness of the bolted joints in the primary disconnect bars. Refer to torque value table, Appendix A, Table A-1, in this manual for the proper torque values. Also check the contact areas on each primary disconnect bar or cluster of fingers for foreign matter that may have accumulated. Clean these areas if necessary. Be sure that a thin film of D50HD35 (formerly D50H47) grease covers the contact areas before putting a breaker in the compartment.

2. Check to see that the breakers match their respective compartments. Each breaker is assigned a part or mark number. This number is shown on the breaker sheets of the summary, the front view drawings, the breaker nameplate, and on the identification card on the breaker shipping carton.

3. To locate the breaker in the proper compartment, refer to the breaker location list on the front view drawing. Find the proper breaker by the identification card on the breaker carton or the mark number on the breaker nameplate. All identical breakers will have the same mark number.

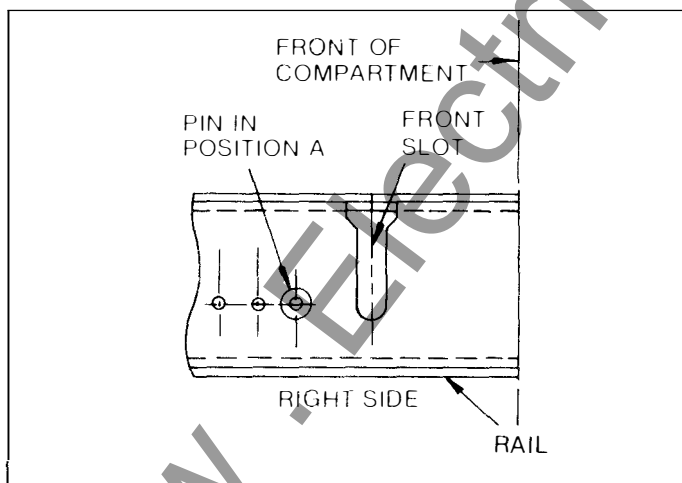

Fig. 5-1. Section view of rejection pin mounting used in AKR-30/30H, AKR-50/50H, and AKRT-50 compartments

#### C. Rejection Feature

Drawout breakers of the same type and rating are interchangeable in their equipment compartments. Drawout breakers of different frame size, type, or short-circuit rating are intentionally made non-interchangeable to prevent inserting the wrong type breaker into a drawout compartment; unique "rejection hardware" is affixed to each breaker and its compartment. When the wrong type breaker is placed on the compartment drawout rails, the bracket on the breaker and the pin on the rail assembly do not mate, and thus prevent the breaker from seating on the rails.

**EXCEPTION:** A breaker with a high short-circuit rating will fit a compartment keyed for a lower short-circuit rating. For example, a AKR-30H breaker can be inserted into an AKR-30 compartment. An AKR-30 breaker, however, will be rejected by an AKR-30H compartment.

Figures 5-1 and 5-2 illustrate the rejection pin mounting used in AKR-30/30H, AKR-50/50H and AKRT-50 compartments.

The AKR-75 and 100 breakers and their fuse carriages are equipped with different style brackets which mate with pins on the drawout rail assembly as shown in Figs. 5-3 and 5-4.

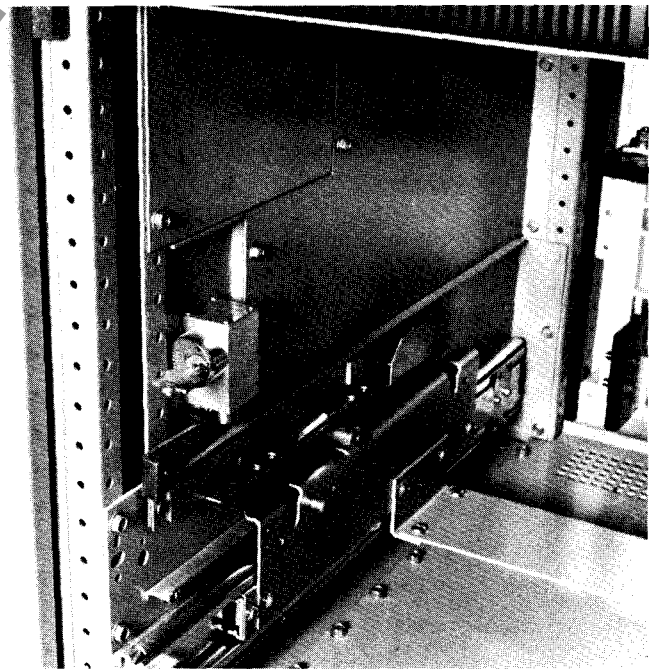

Fig. 5-2. Photograph of rejection pin mounting used in AKR-30/30H, AKR-50/50H, and AKRT-50 compartments

## SECTION V—Installing and Removing Circuit Breakers

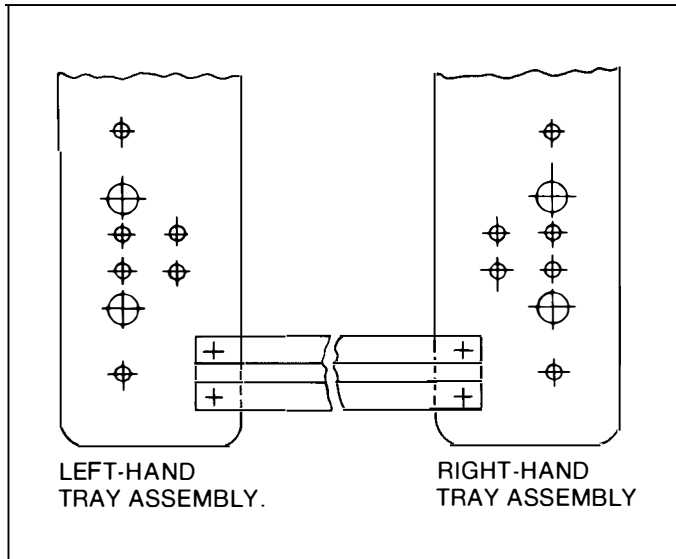

Fig. 5-3. Section view of drawout rail assemblies used in AKR-75 and AKR-100 compartments

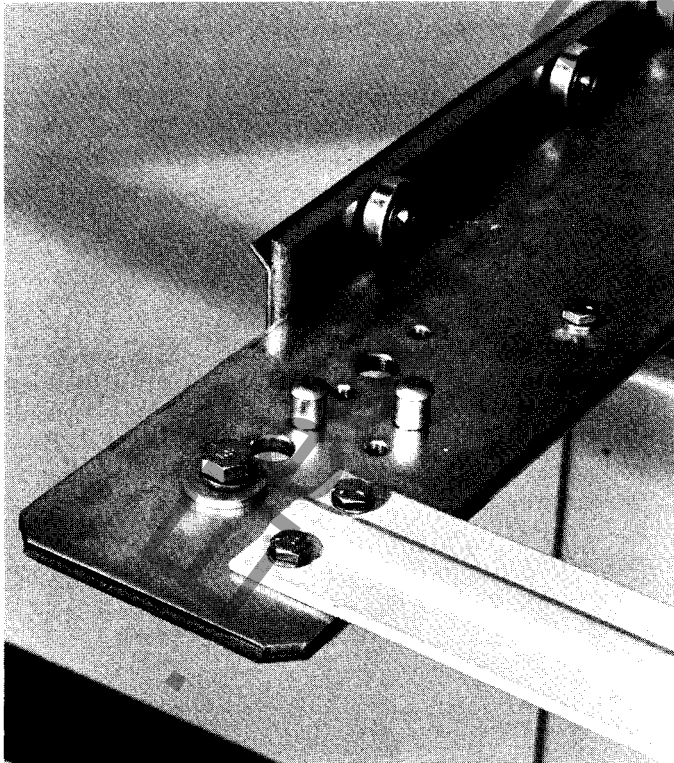

Fig. 5-4. Photograph of drawout tray assembly used in AKR-75 and AKR-100 compartments

**NOTE:** If a breaker is rejected by the drawout rails, check the breaker type and rating against the job drawing.

The complete rejection pin pattern code is included in Appendix B.

### 5.2—Installing the AKR Circuit Breakers

#### A. Prior to Installation

Prior to lifting a breaker to its intended compartment location, observe the following precautions:

##### PRECAUTIONS

1. Check the compartment to ensure that it is free of foreign objects.
2. Verify that the breaker is the correct type for that compartment.
3. Ensure that the breaker is OPEN.
4. Apply a thin fresh coat of D50HD35 (formerly D50H47) lubricant to the breaker's primary disconnects.
5. Ensure that the racking on the breaker are correctly positioned for initial engagement with the pins in the compartment. To do this, insert the racking handle and rotate it fully counter-clockwise.

#### B. Installation Procedures

To install the AKR circuit breakers, proceed as follows

1. Carefully place the breaker in front of the section in which it is to be installed. See Fig. 5-5.
2. Open the breaker compartment door by squeezing the pinch-type latch.
3. Using the switchgear hoist or a suitable lifting mechanism (and spreader rig for AKR-30/50 and AKRU-30/50 breakers), raise the breaker about one-half inch above the elevation of the rails. See Fig. 5-6. Insert the spreader bar hooks in the *forward* slots for non-fused AKR-30/50 breakers and in the *rear* slots for fused AKRU-30/50 models.

**WARNING:** DO NOT STAND UNDER THE CIRCUIT BREAKER DURING THE HOISTING OPERATION.

# AKD-8 Low-voltage Switchgear

## SECTION V—Installing and Removing Circuit Breakers

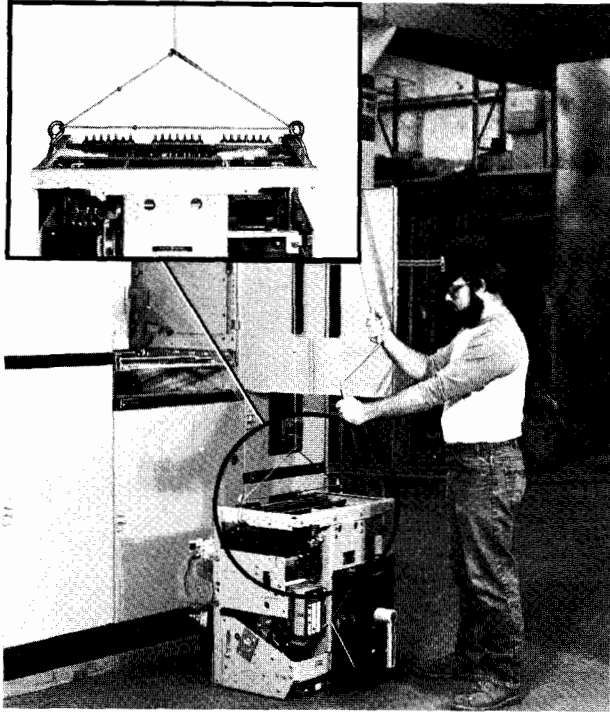

Fig. 5-5. Pay out hoist cable. Attach hoist to circuit breaker

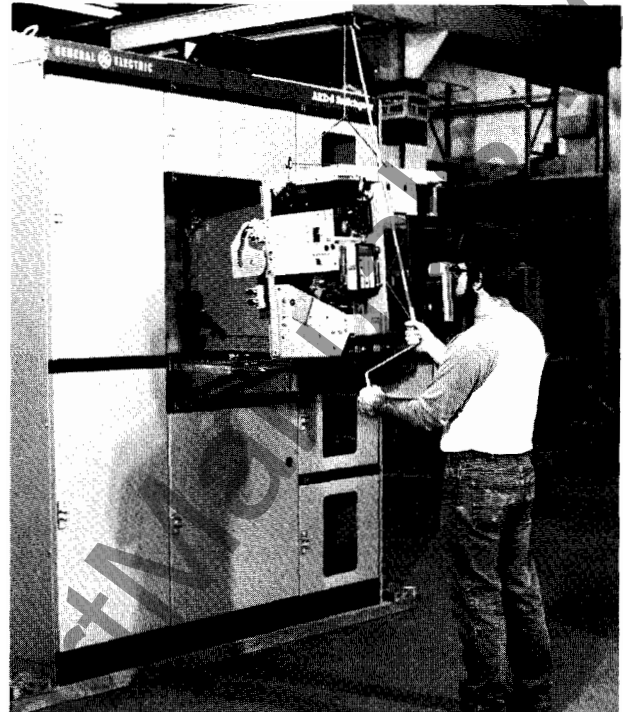

Fig. 5-7. Pull rails out completely from the circuit breaker compartment

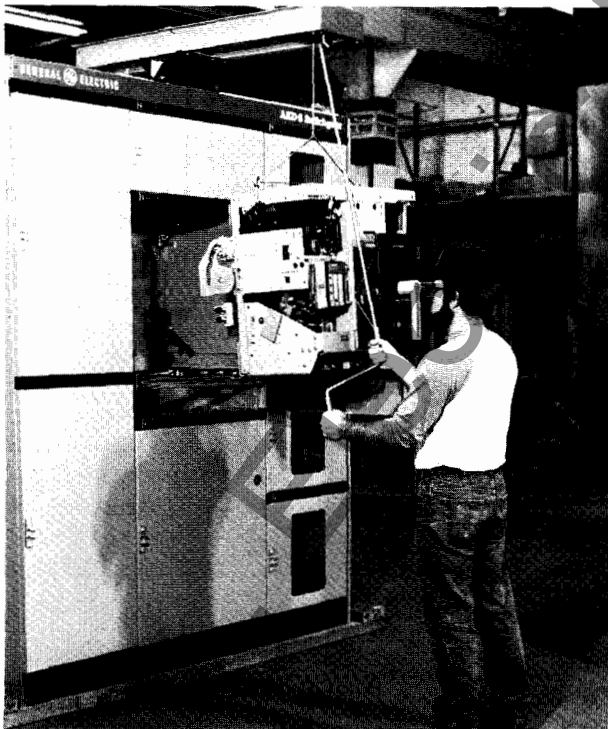

Fig. 5-6. Hoist breaker about one-half inch above rails

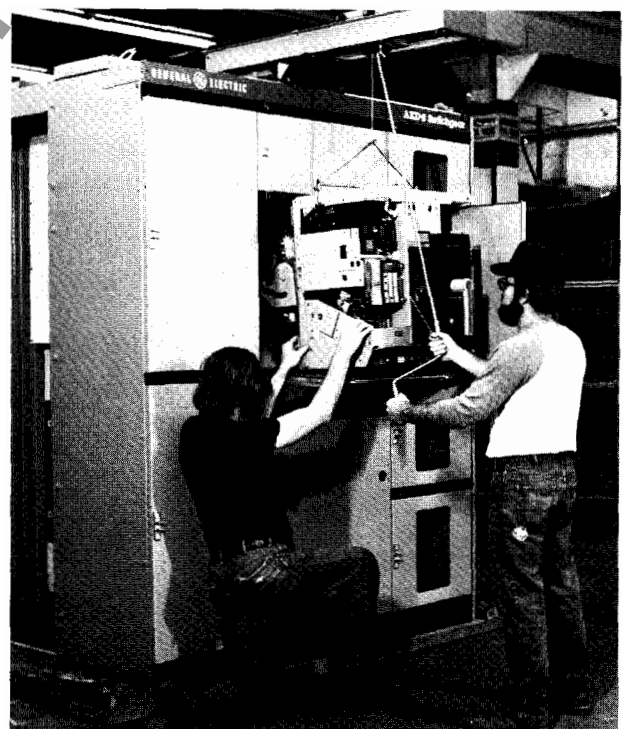

Fig. 5-8. Lower the breaker onto locating pins on the tray. Remove the hoist cable.

## SECTION V—Installing and Removing Circuit Breakers

**CAUTION:** WHEN USING THE SWITCHGEAR HOIST, DO NOT UNWIND THE CABLE COMPLETELY FROM THE DRUM. TO LIFT THE BREAKER, TURN THE HOIST OPERATING CRANK CLOCKWISE. TO LOWER THE BREAKER, TURN THE HOIST OPERATING CRANK COUNTERCLOCKWISE.

4. Pull the rails out completely from the circuit breaker compartment, Fig. 5-7. Due to a different drawout mechanism for the larger AKR-75/100 breakers, refer to Section 5.3 for specific details on mounting these breakers on their drawout trays.

5. Slowly lower and guide the breaker to allow the breaker mounting pins to drop into the slots in the rails. See Fig. 5-8. Remove the lifting device. Failure to seat properly may indicate the breaker is being barred by the rejection pins in the drawout rails. With the AKR-30/50 or AKRU-30/50 breakers, the breaker is now completely mated to the drawout mechanism (rails). With the AKR-75/100 breakers, it is necessary to bolt the breaker to the drawout tray.

6. Push the breaker into the compartment until it reaches the rail stops. See Fig. 5-9. This is the DISCONNECT position. At this point, the racking arms must be positioned to engage the fixed racking pins in the compartment.

7. Close the compartment door.

8. Engage the racking handle. With the AKR-30/50 and AKRU-30/50 breakers, the racking handle is engaged by pushing the trip button in the breaker escutcheon, sliding the cover below it to the right, and inserting the handle on the jackshaft. See Fig. 5-10.

9. Rotate the handle clockwise as far as it will go. Toward the end, a high force will be felt as the disconnect fingers on the breaker engage the stationary studs. Several turns later, the stop will be encountered. The position indicator on the side of the breaker escutcheon will display the word CONNECTED, flush with the breaker door.

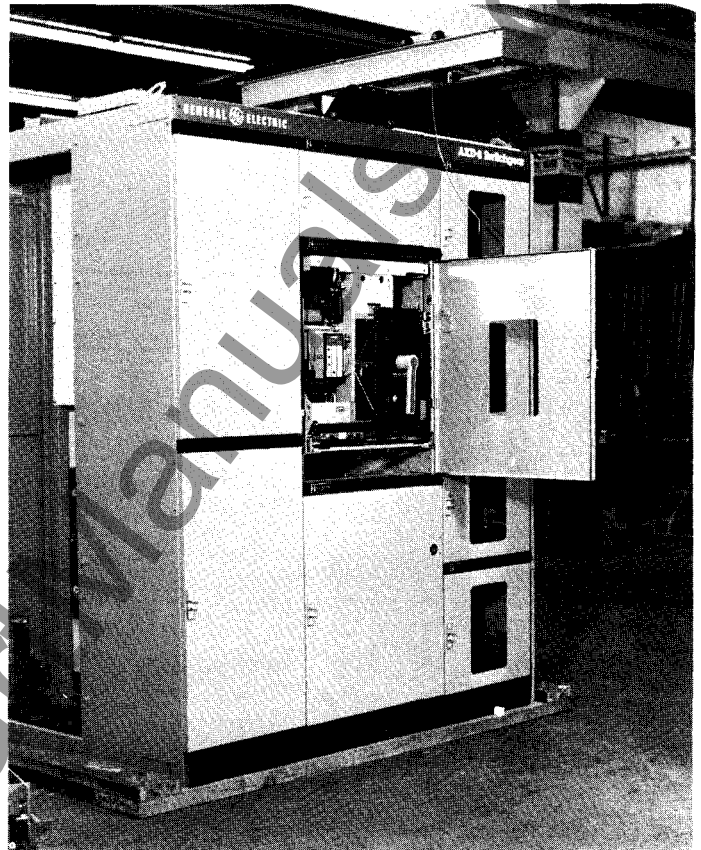

Fig. 5-9. Push the breaker in completely. Close the door.

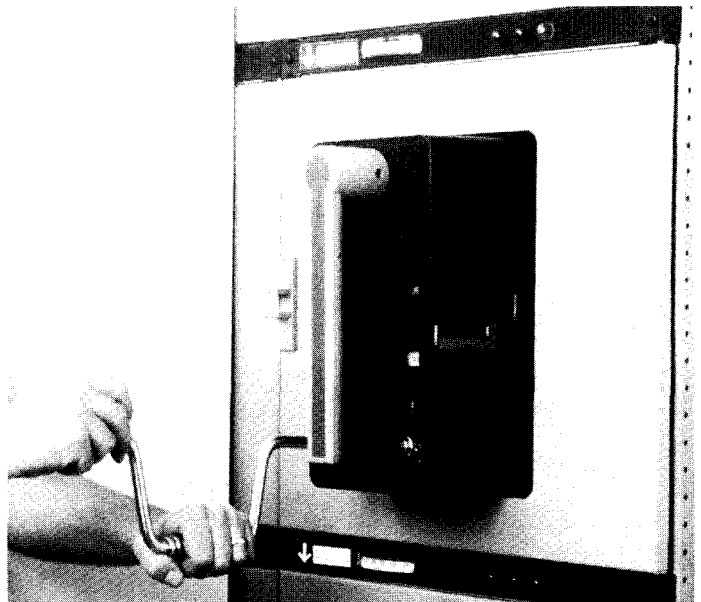

Fig. 5-10. Engage the racking crank with the racking screw (AKR-30/50)

# AKD-8 Low-voltage Switchgear

## SECTION V—Installing and Removing Circuit Breakers

### 5.3—Mounting the AKR-75/100 Circuit Breaker on the Drawout Tray

**WARNING:** DO NOT STAND UNDER THE CIRCUIT BREAKER DURING THE HOISTING OPERATION.

**CAUTION:** WHEN USING THE SWITCHGEAR HOIST, DO NOT UNWIND THE CABLE COMPLETELY FROM THE DRUM. TO LIFT THE BREAKER, TURN THE HOIST OPERATING CRANK CLOCKWISE. TO LOWER THE BREAKER, TURN THE HOIST OPERATING CRANK COUNTERCLOCKWISE.

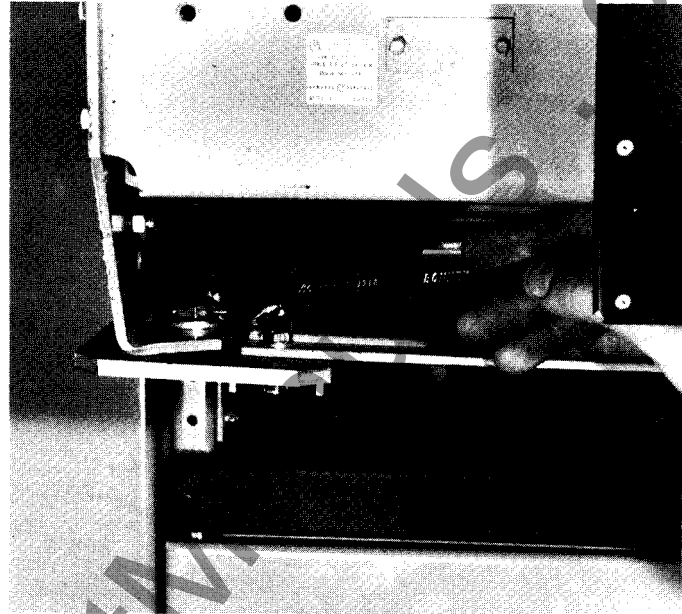

Fig. 5-11. Securing AKR-75/100 breakers to drawout tray

To mount the AKR-75/100 circuit breaker on the drawout tray, proceed as follows:

1. Pull the drawout tray all the way out to its WITHDRAWN limit.
2. Lower the breaker over the tray until it is about one-half inch above the two dowel pins on the tray. Push the breaker back into the compartment until the rear bottom flange of the breaker rests against the guides behind the dowel pins.
3. Slowly lower and guide the breaker onto the tray so the holes in the rear flange fit over the two dowel pins. When correctly positioned on the dowel pins, the breaker's rear and side bottom flanges will rest firmly on the tray.

**NOTE:** Failure to seat properly may indicate the breaker is being barred by the rejection pins in the draw out rails.

4. Secure the breaker to the tray by inserting and tightening two  $\frac{3}{8}$ -inch hex head screws into the front holes of its side flange as shown in Fig. 5-11.
5. Push the breaker into the compartment until the spring discharge stop engages, preventing further movement. This is the DISCONNECTED position. At this point, the racking cams are positioned to engage the fixed racking pins in the compartment, ready to begin the racking motion.

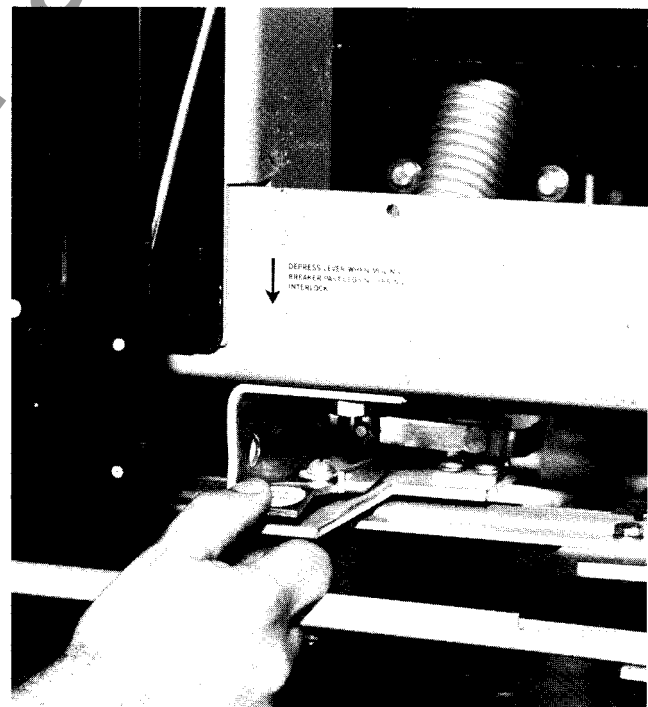

Fig. 5-12. Release lever used on manually operated breaker models in place of spring discharge interlock

## SECTION V—Installing and Removing Circuit Breakers

**NOTE:** Manually operated breaker models do not employ a spring discharge interlock. It is unnecessary because their operating mechanism never statically position the springs in a fully charged state. However, to provide the necessary means for mechanically securing the breaker in the DISCONNECTED position, a position stop is employed. It has a release lever (Fig. 5-12) marked "Push to Withdraw" and is located in the same place as the spring discharge release lever on electrically operated breakers.

### 5.4—Removing the AKR-30/50/T50 and AKRU-30/50 Circuit Breakers

**WARNING:** DO NOT STAND UNDER THE CIRCUIT BREAKER DURING THE LOWERING OPERATION.

**CAUTION:** WHEN USING THE SWITCHGEAR HOIST, DO NOT UNWIND THE CABLE COMPLETELY FROM THE DRUM. TO LIFT THE BREAKER, TURN THE HOIST OPERATING CRANK CLOCKWISE. TO LOWER THE BREAKER, TURN THE HOIST OPERATING CRANK COUNTERCLOCKWISE.

To remove the AKR-30/50/T50 and AKRU-30/50 circuit breaker, proceed as follows:

1. With the door closed and latched, trip the breaker.
2. Insert the racking handle and rotate it counterclockwise until the breaker travels from CONNECTED through TEST to the DISCONNECTED position, as indicated by the jackscrew coming to a stop. This operation should be performed with the door closed. If the breaker closing spring is fully charged, it will be automatically discharged a few turns before the end of the racking action.
3. Open the compartment door. Pull the breaker out to the limit of rail travel. This is the WITHDRAWN position.
4. Before proceeding, visually check the breaker's spring charge and close indicators to verify that breaker is open and the springs are discharged.
5. Attach the lifting device and hoist the breaker until its mounting pins clear the rail's slots.
6. Push the drawout rails back into the compartment.

7. Swing the breaker forward until the primary disconnects clear the compartment.

8. Lower the breaker onto a flat surface free of protrusions that could damage the breaker's internal parts.

### 5.5—Removing the AKR-75/100 Circuit Breakers

**WARNING:** DO NOT STAND UNDER THE CIRCUIT BREAKER DURING THE LOWERING OPERATION.

**CAUTION:** WHEN USING THE SWITCHGEAR HOIST, DO NOT UNWIND THE CABLE COMPLETELY FROM THE DRUM. TO LIFT THE BREAKER, TURN THE HOIST OPERATING CRANK CLOCKWISE. TO LOWER THE BREAKER, TURN THE HOIST OPERATING CRANK COUNTERCLOCKWISE.

To remove the AKR-75/100 circuit breakers, proceed as follows:

1. With the door closed and latched, trip the breaker.
2. Insert the racking handle and rotate it counterclockwise until the breaker travels from CONNECTED through TEST to the DISCONNECTED position, as indicated by the jackscrew coming to a stop. This operation should be performed with the door closed.
3. Open the door. On electrically operated breakers, depress the spring discharge lever (Fig. 5-12) to discharge the breaker's closing springs. While holding this lever depressed, pull the breaker all the way out to its WITHDRAWN position. On manually operated breakers, this release lever is labeled "PUSH TO WITHDRAW."
4. Before proceeding, visually check the breaker's spring charge and close indicators to verify that the breaker is open and the springs are discharged.
5. Remove the two  $\frac{3}{8}$ -inch hex head screws (Fig. 5-11) which fasten the breaker to the compartment tray.
6. Attach the lifting device to the cutout notches in the top wraparound frame of the breaker, using care to prevent damage to the wiring.
7. Lift the breaker approximately one-half inch off the dowel pins. Push the tray back into the compartment.
8. Swing the breaker forward until the primary disconnects clear the compartment. Lower the breaker onto a flat surface free of protrusions that could damage the breaker's internal parts.

# AKD-8 Low-voltage Switchgear

## SECTION V—Installing and Removing Circuit Breakers

### 5.6—Installing and Removing AKRU-30/50 Fused Circuit Breakers

Except for the open fuse lockout device and the integrally mounted fuses on the upper studs, the AKRU-30 and -50 breakers are identical to the unfused AKR-30 and -50 models. To compensate for added weight of the fuses and their mounting supports, the lifting hoist spreader bar hooks must engage the rear (away from escutcheon) slots on the breaker frame. Later production breakers have one slot on each side located for correct balance. The procedural steps for installing and removing the AKRU-30/50 breakers from the AKD-8 switchgear equipment are the same as that described in paragraph 5.4 for non-fused AKR-30/50 breakers.

### 5.7—Installing Fuses in AKRU-30/50 Circuit Breakers

The fuses on AKRU-30/50 breakers are mounted on the line side primary disconnect CONDUCTORS. The Class L fuses are mounted as shown in Fig. 5-13. Other than the 800A size, which has a single mounting hole per tang, each Class L fuse tang has two holes sized for one-half inch bolts.

Appendix G includes a tabulation of the range of fuse sizes available for these breakers including catalog numbers of both General Electric CLF and Gould Shawmut Fuses.

Class J fuses rated 300 through 600A have one mounting hole per tang. The 300, 350 and 400A sizes require copper adapter bars as shown in Fig. 5-14.

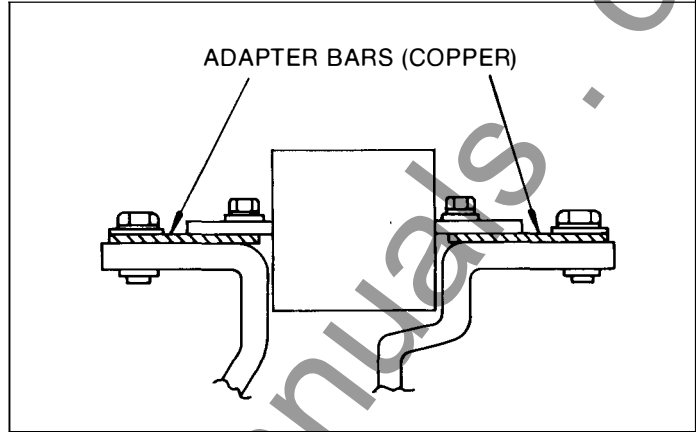

Fig. 5-14. Mounting for 300, 350, and 400-ampere Class "J" fuses on AKRU-30 breakers

A special fuse is available for use with AKRU-50 breakers. This fuse provides a melting time-current characteristic that coordinates with 1600A trip devices. Compared physically with a 2500A, NEMA Class L fuse, the special fuse is more compact (shorter) and its tangs are specially configured and offset to achieve the required pole-to-pole fuse spacing. A special primary disconnect assembly mounts directly on the outboard tang of the fuse. Because of their unique mounting provisions, the following procedure should be adhered to when replacing these fuses (Fig. 5-15):

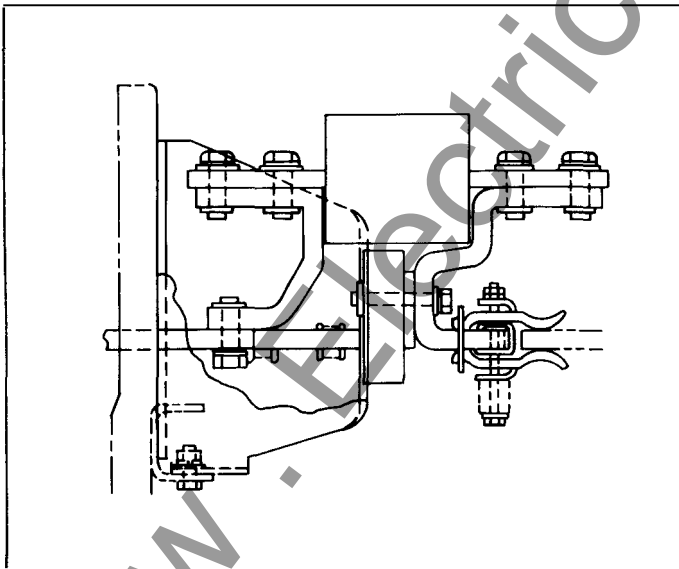

Fig. 5-13. Typical mounting for Class "L" fuse on AKRU-30/50 breakers

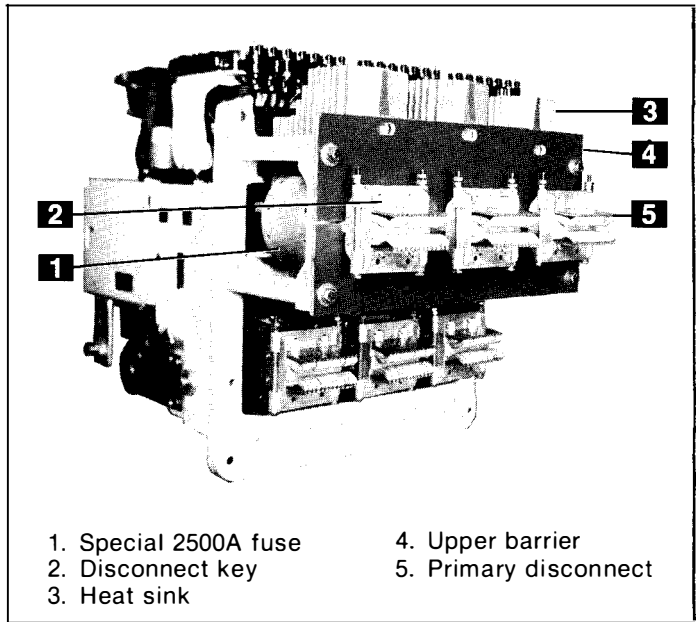

Fig. 5-15. AKRU-50 breaker with special 2500-ampere fuse

## SECTION V—Installing and Removing Circuit Breakers

1. Remove the primary disconnect assembly from the fuse tang. This is accomplished by first loosening the two keys (2), Fig. 5-15, via their holding screw and pulling them upward and out. After the keys are removed, pull the disconnect assembly off the end of the fuse tang.

**NOTE:** This removal does not disturb the disconnect's clamping force adjustment.

2. Remove the upper barrier (4).
3. Detach the inboard end of the fuse by removing the two ½-13 NC bolts. A ratchet and socket with a short extension will be required.
4. Remove the heat sink (3).
5. Remove the fuse.

6. Install the new fuse by reversing the disassembly procedure. Ensure that the mating faces of the fuse and heat sink are clean.

**CAUTION:** WHEN REPLACING THE FUSE IN THE RIGHT POLE (PLAN VIEW) OF THE BREAKER, NOTE PARTICULARLY THAT THIS FUSE IS MOUNTED DIFFERENTLY FROM THE OTHER TWO FUSES. AS SHOWN IN FIG. 5-16, FOR THIS PHASE THE FUSE IS ROTATED 180 DEGREES ABOUT ITS AXIS SO THAT ITS INBOARD TANG IS POSITIONED *BENEATH* THE BREAKER STUD. THIS TANG IS OFFSET WITH RESPECT TO THE OPPOSITE END, (FIG. 5-17), SO THAT ROTATING THE FUSE DOES NOT ALTER THE POSITION OF THE PRIMARY DISCONNECT.

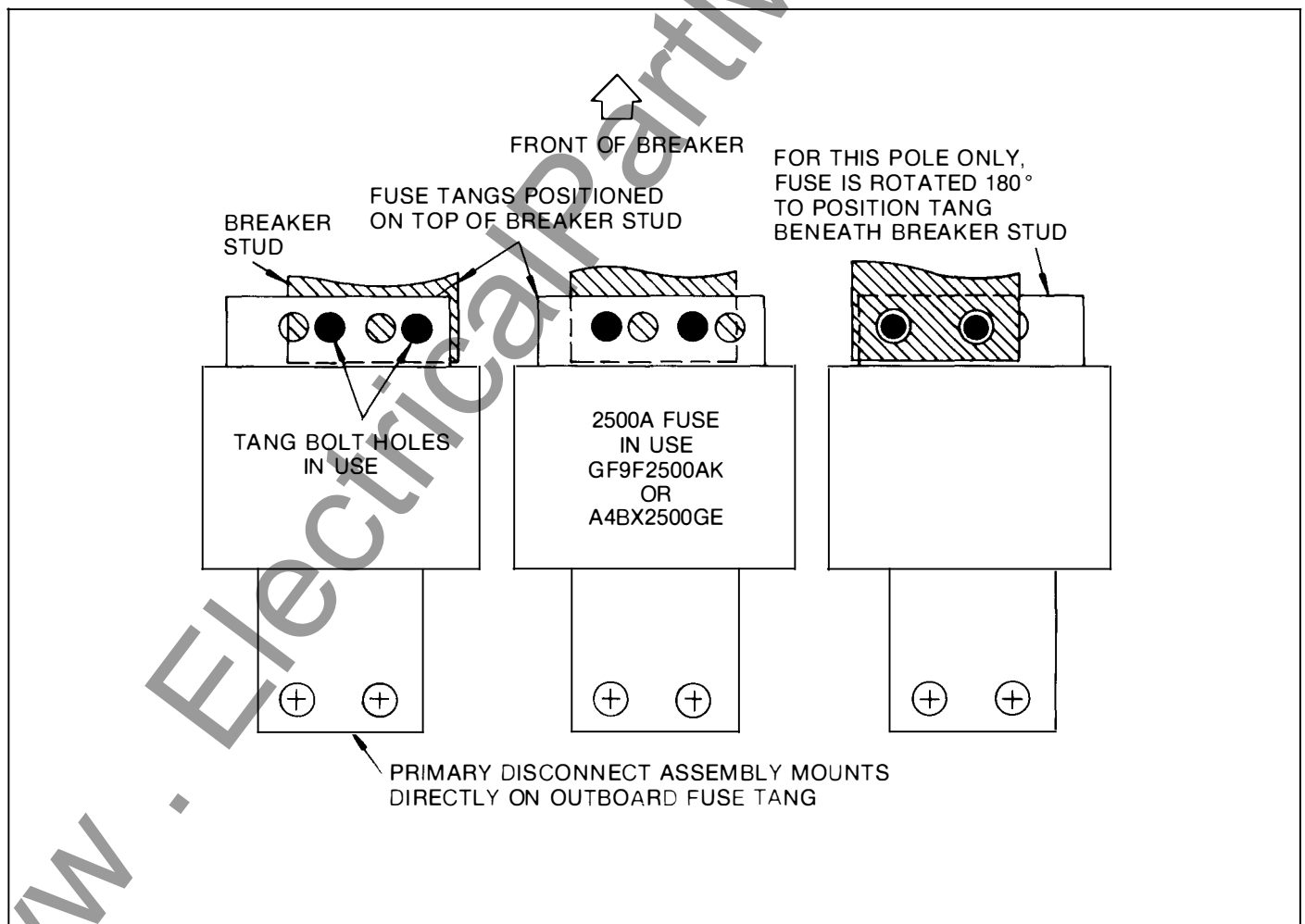

Fig. 5-16. Plan view of AKRU-50 breaker showing 2500-ampere fuse tang positions

# AKD-8 Low-voltage Switchgear

## SECTION V—Installing and Removing Circuit Breakers

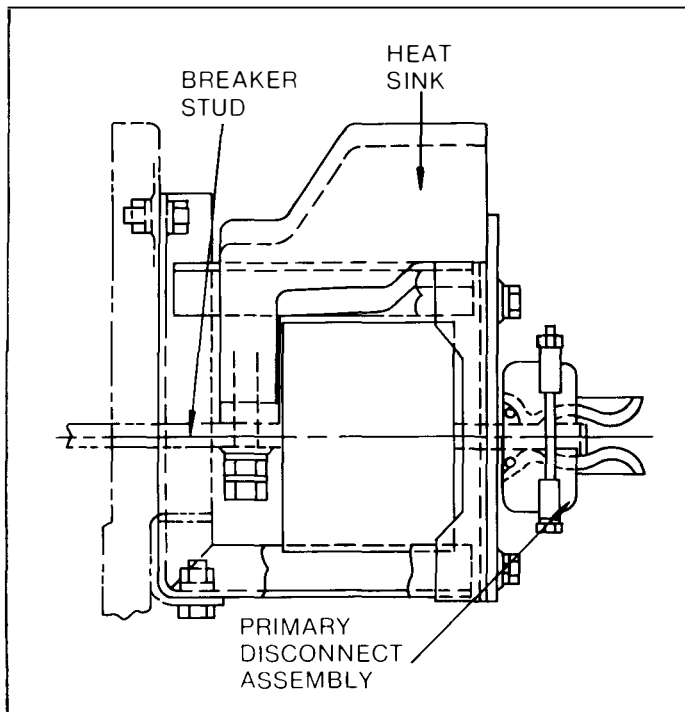

Fig. 5-17. Mounting for special 2500-ampere fuse on AKRU-50 breaker

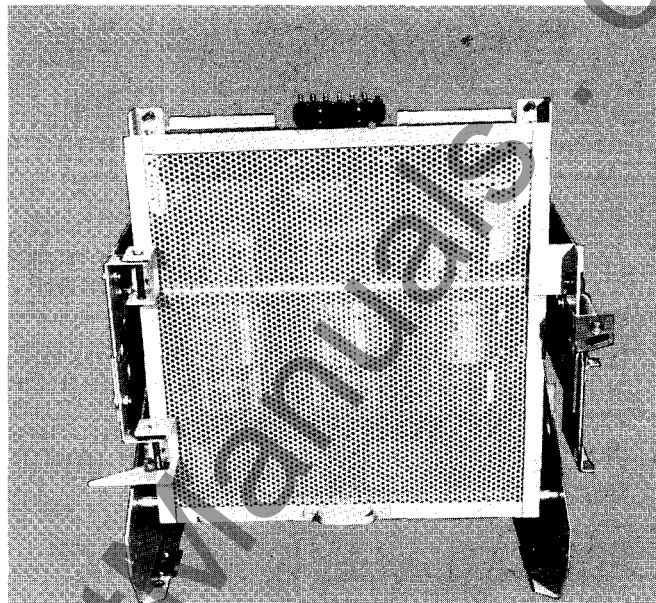

Fig. 5-18. Fuse rollout carriage (FRO) showing hinged, perforated steel screen panel

### 5.8—Installing and Removing Fuse Rollout Elements (FRO)—30-Inch Wide Compartments

The FRO is racked into and out of its compartment just like a breaker. However, the fuse and breaker compartments each are equipped with keylocks to prevent racking the FRO when its associated breaker is closed. The FRO also utilizes a rejection pin scheme similar to that used on AKR-75/100 breakers, to prevent installation of an incorrect FRO.

All FRO models feature a hinged, perforated steel screen panel in front of the fuses as shown in Fig. 5-18. This panel can be opened to allow access to the fuses, Fig. 5-19, only when the FRO is in the WITHDRAWN position. In all other positions, an interference plate attached to the right side of the panel prevents it from being opened. Operation of the breaker compartment keylock is the same for all models. With the breaker open, the key can be removed; this extends the lock bolt, thereby maintaining the breaker in a trip-free state while in the CONNECTED position. The breaker can be racked at will regardless of the keylock position.

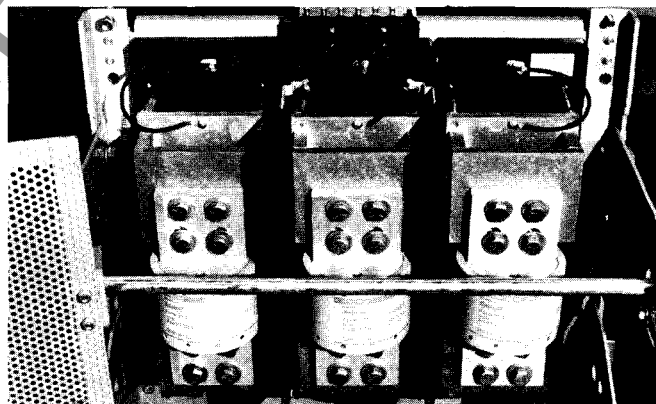

Fig. 5-19. View showing perforated panel open to allow easy access to fuses

The FRO compartment is KEY INTERLOCKED with the associated breaker immediately above. The FRO racking mechanism is locked in an inoperative position until a key is inserted in the FRO key interlock, Fig. 5-20. The key is captured in the breaker compartment KEY INTERLOCK, Fig. 5-21, and is not released until the breaker is tripped.

## SECTION V—Installing and Removing Circuit Breakers

The breaker is prevented from being closed until the key is reinserted and captured in the breaker compartment key interlock mechanism.

Secondary disconnects on the FRO provide the voltage signals across each fuse to the OPEN FUSE LOCKOUT DEVICE on the associated circuit breaker, Fig. 5-22.

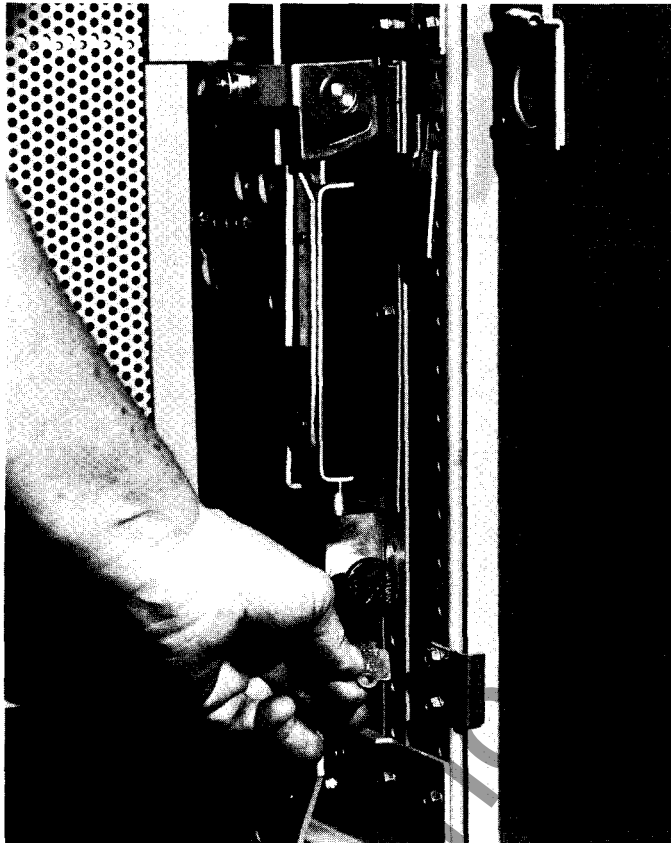

Fig. 5-20. View showing insertion of key in FRO key interlock to release FRO racking mechanism

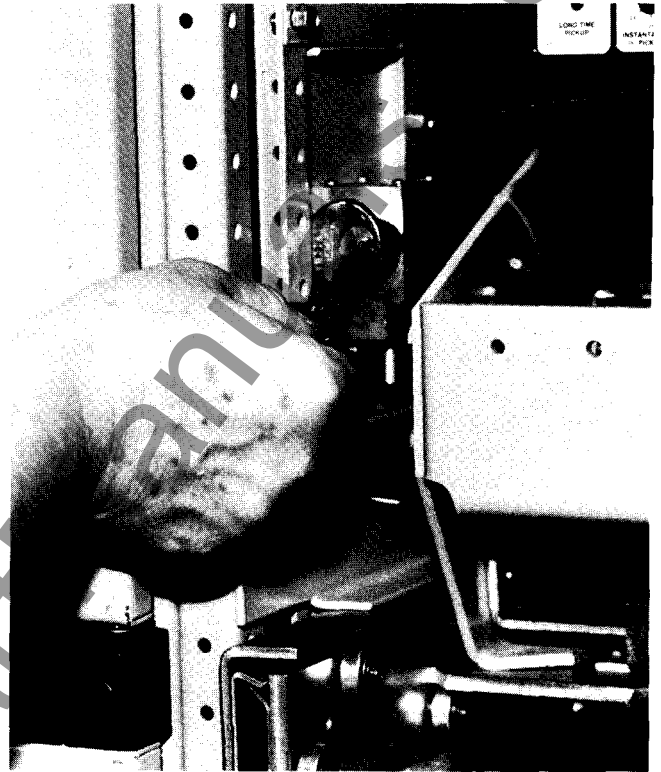

Fig. 5-21. Key is captured in key interlock until breaker is tripped

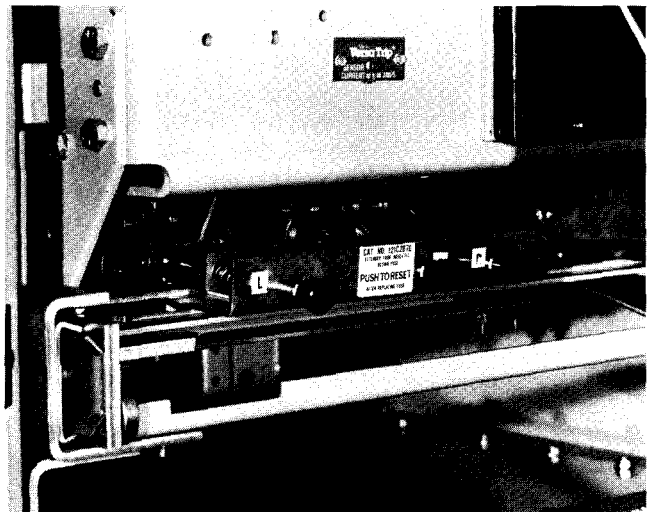

Fig. 5-22. View showing Open Fuse Lockout Device on the associated breaker

# AKD-8 Low-voltage Switchgear

## SECTION VI—Testing and Inspection

### 6.1—General

After the equipment has been installed and all connections made, it must be tested and inspected before it is put in service. Although the equipment and devices have been tested at the factory, a final field test must be made to be sure that the equipment has been properly installed and that all connections are correct.

**WARNING:** THE EQUIPMENT MUST BE COMPLETELY DE-ENERGIZED WHILE THE TESTS ARE IN PROGRESS.

Directions for testing relays, instruments, and meters are given in the instruction book furnished for each device. The proper settings of the protective relays and circuit breaker trip programmers are normally determined from a complete power system coordination study performed by the purchaser or his consultant; therefore, the settings of these devices must be made by the purchaser. When the equipment is shipped from the factory, the time dial of all inverse-time induction disc relays (i.e., IAC types) is set to zero to prevent contact bounce during transportation.

**NOTE:** The trip setting adjustments of the trip programmer on circuit breakers may be in any position when shipped from the factory and must be correctly positioned prior to energization of the equipment.

General instructions for setting the relays are given in the Relay Instruction Book.

The extent of the tests on the equipment as a whole will depend on the type and function of the equipment. Tests which should be performed, however, include circuit breaker operation, and switchgear meggering, phasing, and grounding checks.

High-potential tests to check the integrity of the insulation are not necessary if the installation instructions are carefully followed. If local codes demand this test, or the purchaser wishes to make high-potential tests, the voltage should not exceed 75 percent of the IEEE factory test voltage.

For the power circuit, the IEEE factory test voltage is two times switchgear rating plus 1000 volts. See Table VI-1. Potential and control power transformers must be disconnected during high-voltage testing.

Table VI-1

Switchgear Voltage Rating	Test Voltage
600V	2200V
480V	1960V
240V	1480V

### 6.2—Key Interlocks

After initial installation of the switchgear equipment, all necessary interlock keys should be inserted into the appropriate locks and all spare keys should be stored in a location in accordance with the owner's established procedures.

**CAUTION:** REFER TO THE KEY INTERLOCK SCHEMATIC INCLUDED IN THE SUMMARY FURNISHED WITH THE EQUIPMENT TO DETERMINE THE SEQUENCE OF OPERATION AND THE CORRECT NUMBER OF OPERATING KEYS REQUIRED. THIS PRECAUTION IS NECESSARY SINCE THE IMPROPER USE OF SPARE KEYS WILL DEFEAT THE INTERLOCKING SCHEME.

### 6.3—Breaker Operation Test

All compartments housing AKR circuit breakers have a TEST position in which the breaker primary contacts are disconnected while the secondary contacts are still engaged. This TEST position permits complete testing of the electrical control circuit without energizing the primary power circuit. When the breaker is first put into service, its control circuit must be thoroughly tested while in this position to make sure that all closing and tripping circuits are complete and functioning properly.

The TEST position is not suitable for inspection and maintenance of the breaker and should therefore be used only for testing breaker operation.

Refer to the appropriate breaker instruction manual for other pre-operational checks on the breakers.

### 6.4—MicroVersaTrip™ Programmer

The calibration of the MicroVersaTrip™ programmer should be checked with the Type TVTS1 test kit, a portable instrument designed for the field testing of MicroVersaTrip solid-state programmers. The complete trip system is comprised of the following components:

1. Solid-state Programmer
2. Phase Current Sensors
3. Flux Shift Magnetic Trip Device
4. When applicable, a Neutral Sensor for units containing a Ground Fault Trip element.

## SECTION VI—Testing and Inspection

All components, except the Neutral Sensor, are integrally mounted in the circuit breaker. When used, the Neutral Sensor is separately mounted in the bus or cable compartment of the switchgear. In drawout construction, it is automatically connected to the programmer in the breaker via a drawout secondary disconnect block.

The test Set is used to perform various programmer tests in two basic modes:

- Testing the Solid-state Programmer Only—Mode “1”
- Testing the Complete Trip System—Mode “2”

**WARNING:** THESE TESTS CAN BE CONDUCTED ONLY ON A DE-ENERGIZED BREAKER—ONE WHICH IS COMPLETELY DISCONNECTED FROM ITS PRIMARY AND CONTROL POWER SOURCES. BEFORE CONNECTING THE TEST SET TO THE BREAKER, ENSURE THAT THE CIRCUIT BREAKER IS COMPLETELY DISCONNECTED FROM ITS POWER SOURCE. ON DRAWOUT EQUIPMENT, RACK THE BREAKER TO ITS DISCONNECTED POSITION. VERIFY THAT THE BREAKER IS OFF.

**CAUTION:** NEVER DISENGAGE THE PROGRAMMER ON A BREAKER THAT IS ENERGIZED AND CARRYING LOAD CURRENT. THIS WILL OPEN-CIRCUIT THE CURRENT SENSORS, ALLOWING DANGEROUS AND DAMAGING VOLTAGES TO DEVELOP.

Complete Instructions for testing the programmer are included with the test set. The publication number is GEK-64464.

### 6.5—Final Steps to Be Taken Before Energizing Equipment

The following steps should be taken before energizing the equipment:

1. Manually exercise all switches, circuit breakers, and other operating mechanisms to make certain they are properly aligned and operate freely.
2. Conduct an electrical insulation resistance test to make sure the switchgear is free from short circuits and grounds. This should be done both phase-to-ground and phase-to-phase with the switches or circuit breakers both opened and closed.
3. Check any electrical relays, meters, or instrumentation to determine that connections are made properly and the devices function properly.
4. Electrically exercise all electrically operated circuit breakers, and other mechanisms (but not under load), to determine that the devices operate properly. An auxiliary source of control power may be necessary to provide power to the electrical operators.
5. Test the ground fault protection system (if furnished) in accordance with the manufacturer's instructions.
6. Set the adjustable current and voltage trip mechanisms to the proper values. Experience has indicated that damage from faults can be reduced if the devices used for overload and short circuit protection are set to operate instantaneously (that is, without intentional time delay) at 115 percent of the highest value of phase current which is likely to occur as the result of any anticipated motor starting or welding currents.
7. Make certain that field wiring is clear of live bus and, where necessary, physically secured to withstand the effects of fault currents.
8. Check to determine that all grounding connections are made properly.
9. Remove all debris, scrap wire, etc., from the switchgear interior before closing the enclosure.
10. Install covers, close doors, and make certain that no wires are pinched and that all enclosure parts are properly aligned and tightened.

# AKD-8 Low-voltage Switchgear

## SECTION VII—Operating the Switchgear

### 7.1—Circuit Breaker Operation

#### A. General

Included below are abbreviated operating instructions for AKR and AKRU circuit breakers. Before activation of the circuit breakers or operation of the switchgear equipment, thoroughly read, and be familiar with, the circuit breaker manuals which will be supplied as supplementary information to this manual.

#### B. Manually Operated Breakers

##### B-1. Closing Manually Operated AKR Circuit Breakers

Manually operated AKR breakers are equipped with a handle and a push button marked CLOSE on the front of the escutcheon. The closing spring must be charged first.

1. FOR AKR-30 AND AKR-50 BREAKERS—A complete charge is accomplished by either rotating the handle counterclockwise back to the normal position or by using three similar cycles of about 50 degrees each.

2. AKR-75 AND AKR-100 BREAKERS—These breakers require the handle to be rotated counterclockwise through 120 degrees and then back, for four cycles. The circuit breaker will close after approximately seven degrees travel of the fourth clockwise movement. A charge-indicator, numbered one to four and visible through the breaker escutcheon, indicates the number of complete handle movements performed.

##### B-2. Tripping Manually Operated AKR Breakers

A mechanically operated trip button, mounted on the breaker escutcheon, operates the trip shaft to open the breaker.

#### C. Electrically Operated Breakers

Electrically operated breakers may be closed by ac control power, or dc (normally station or standby battery) control power. Refer to elementary diagrams for information on control circuitry.

The breakers may be controlled by a push-button switch on the breaker escutcheon, by a breaker control switch, or by a relay contact. The control switch or relays may be located in the equipment which houses the breaker, or may be installed in a remote location. Fuses are located in the instrument tray just above the breaker compartment.

#### D. Electrical Tripping of AKR Breakers

A shunt trip device is used for electrical tripping. A normally open auxiliary switch "a" contact opens the control circuit after the breaker opens.

### 7.2—Circuit Breaker Drawout Operation

#### A. Breaker Positions

Refer to Fig. 7-1. The drawout operation features four positions:

1. CONNECTED—In the CONNECTED position, the primary and secondary disconnects are fully engaged. The breaker must be tripped before it can be racked in or out of this position.

2. TEST—When in the TEST position, the primary contacts are disconnected, but the secondary contacts remain engaged. This allows complete breaker operation without energizing the primary circuit.

3. DISCONNECT—In the DISCONNECTED position, neither primary or secondary contacts are made. Breakers may be racked between these three positions with the compartment door closed.

4. WITHDRAWN—With the door open, the breaker can be pulled out manually from the DISCONNECTED to the WITHDRAWN position. Here, the breaker is completely out of its compartment, ready for removal.



Fig. 7-1. AKD-8 switchgear circuit breaker in drawout position

## SECTION VII—Operating the Switchgear

### B. Drawout Operation

All breakers are supported on telescoping drawout rail assemblies mounted on the side walls of the breaker compartments. On small frame breakers (AKR-30/50/50T), two pins on each side of the breaker rest in slots in the rails. On large frame breakers (AKR-75/100), the rails are part of a drawout tray to which the breaker is bolted.

Motion is provided by a mechanism mounted on the breaker. This mechanism drives racking cams which engage pins anchored to each side of the compartment.

The cams are driven by a removable racking handle which engages the mechanism. On small frame breakers, the handle is inserted through an opening in the breaker escutcheon; on large frame breakers, the handle is inserted in an opening in the left side of the door.

Turning the handle in a clockwise direction drives the breaker into the compartment. As the breaker disconnect fingers engage the stationary studs, a high force will be felt. Turn the racking handle as far as it will go to be sure the disconnect fingers are completely engaged.

The position of the breaker is indicated by markings which appear on both sides of the breaker escutcheon as it moves through the door cutout.

### 7.3—Front Doors

#### A. Operation

The front access doors on all general AKD-8 Switchgear are hinged and equipped with a pinch-type latch, Fig. 7-3. To open the door, place your thumb and forefinger on the latch and squeeze.

#### B. Removal and Installation

Refer to Fig. 7-3 and remove or install the switchgear front doors.

##### B-1. Door Removal

To remove the AKD-8 Switchgear door, proceed as follows:

1. Open door.
2. Remove the two screws holding the top hinge pin plate to the inside of the door flange. Remove hinge. See Fig. 7-3.
3. Move the top of the door away from the switchgear and lift the door out of the lower hinge pin socket.

##### B-2. Door Installation

To install the AKD-8 Switchgear door, proceed as follows:

1. Place lower hinge pin into hinge pin socket on switchgear. See Fig. 7-3.
2. Swing door open and align hinge pin socket.
3. Install hinge pin plate into door with pin inserted in socket. Secure the hinge pin to the door with the two attaching screws.
4. Close door.

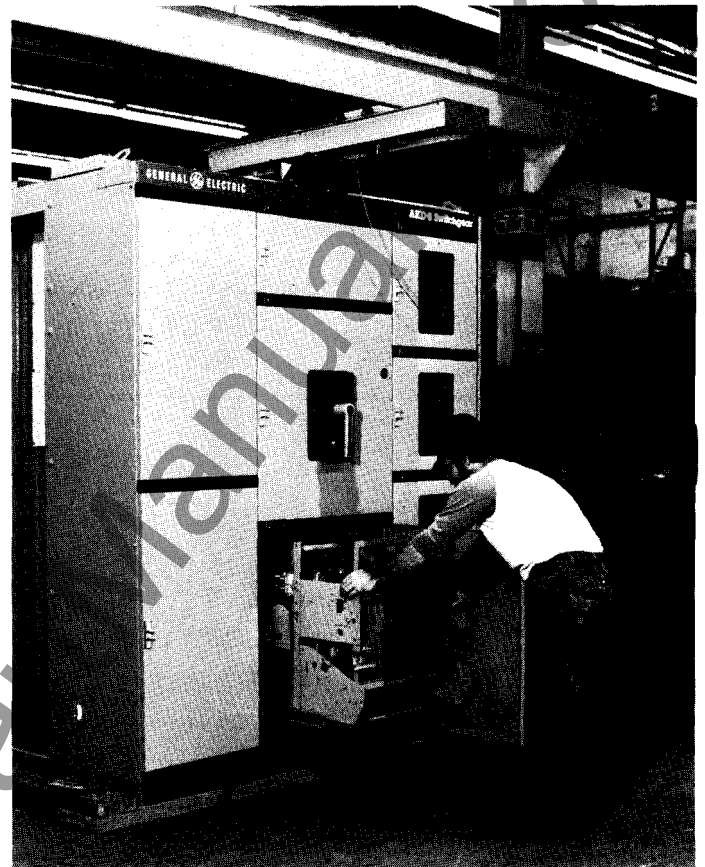

Fig. 7-2. AKD-8 switchgear front access doors are hinged with pinch-type latch

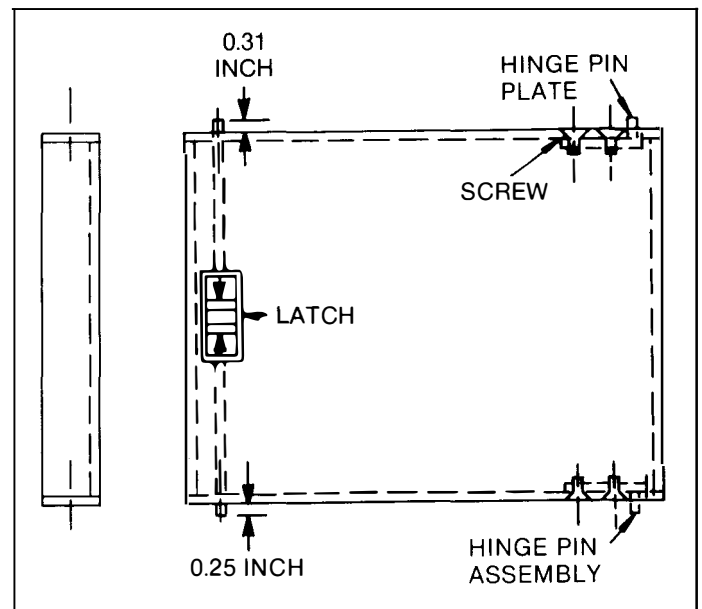

Fig. 7-3. Drawing showing front access details

# AKD-8 Low-voltage Switchgear

## SECTION VII—Operating the Switchgear

### 7.4—AKD-8 Switchgear Accessories

#### A. Future Circuit Breaker Compartments

Breaker compartments designed for future use are complete and ready to use. These breaker compartments have a plastic panel to cover the door cutout, Fig. 7-4, and a protective steel barrier to shield live primary stabs. To prepare the circuit breaker compartment for use, remove the plastic outer cover and protective steel barrier.

**WARNING: TERMINALS BEHIND THE STEEL BARRIER MAY BE ELECTRICALLY HOT.**

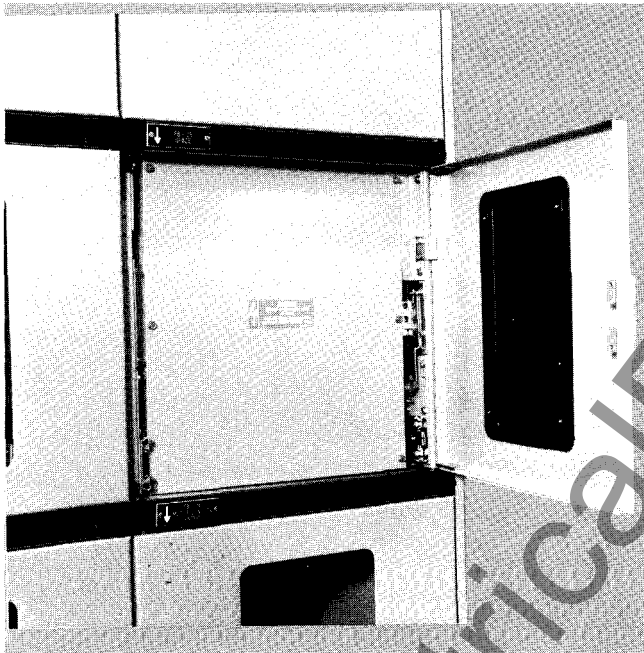

Fig. 7-4. Future-use breaker compartments

#### B. Circuit Breaker Key Interlock

##### B-1. General

A circuit breaker key interlock is available to provide protection against unauthorized operation. See Fig. 7-5. The key interlock is mounted with two one-way screws and lock-washers on the left side of the breaker compartment.

The interlock system is designed so that the key may be removed from the lock only if the breaker is tripped and the lock bolt is extended. With the bolt extended, the breaker is rendered trip free only in the CONNECTED position in this compartment.

The breaker may be operated (closed and tripped) in the TEST or DISCONNECTED positions even when the lock bolt is extended and the key removed.

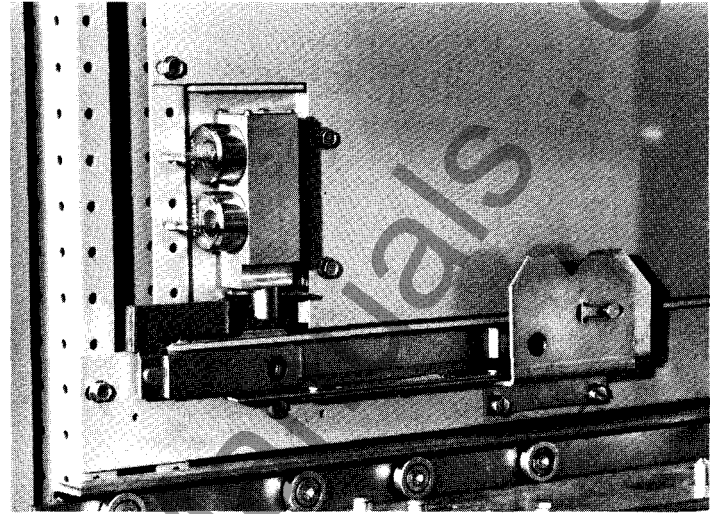

Fig. 7-5. View showing circuit breaker key interlock to provide protection against unauthorized operation

##### B-2. Key Interlock Operation Check

The operation of the key interlock should be checked as follows:

1. With the breaker in the CONNECTED POSITION, manually trip the breaker. This then allows the interlock trip slide to be pushed in. When the trip slide is in, the lock bolt may be extended and the key removed. The breaker will remain trip free in the CONNECTED position until the key is returned and the lock bolt is retracted.
2. If desired, the breaker may be moved to either the TEST or DISCONNECTED position while the key is removed from the lock. In these positions, the breaker can be operated for checking or maintenance.

#### C. Rackout Mechanism Padlock Device

##### C-1. General

A rackout mechanism padlock device is available to prevent unauthorized racking of the breaker. The rackout mechanism for AKR-30, AKR-50, AKRU-30 and AKRU-50 circuit breakers may be locked in either the DISCONNECTED, TEST or CONNECTED position. AKR-75 and AKR-100 circuit breakers may be locked in the DISCONNECTED or TEST position.

##### C-2. Padlocking the AKR-30/50/T50 AND AKRU-30/50 Breakers. (See Fig. 7-6.)

To padlock these breakers, proceed as follows:

1. The circuit breaker compartment door must be opened to put the padlock on; however, there is no interference with the door after the padlock has been placed in position.
2. With the breaker moved to the appropriate position, push down on the sliding lock plate until its holes are aligned with those in the post plate. Insert and lock the padlock.

## SECTION VII—Operating the Switchgear

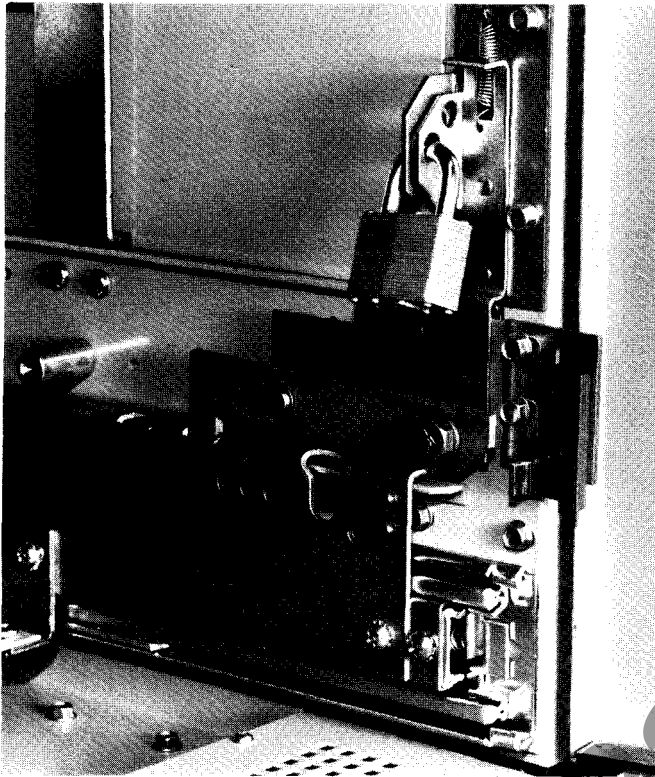

Fig. 7-6. Racking mechanism padlock device (AKR-30/50/T50 and AKRU-30/50 breakers)



Fig. 7-7. Racking mechanism padlock device (AKR-75/100 breakers)

### C-3. Padlocking the AKR-75/100 Breakers. (See Fig. 7-7.)

1. The circuit breaker compartment door must be opened to put the padlock on; however, there is no interference with the door after the padlock has been placed in position.

2. The padlock device will permit locking the cradle in the DISCONNECTED or TEST position. Hasps, which pivot on the corner post in combination with the circuit breaker crank interlock, prevent movement of the breaker from its locked position.

3. Align the appropriate hasp (front hasp for DISCONNECTED position or rear hasp for TEST position), insert, and lock the padlock.

### D. Installing and Removing Metering Current Transformers

**WARNING:** DO NOT OPERATE ANY CURRENT TRANSFORMER WITH SECONDARIES OPEN-CIRCUITED. BE SURE TO SHORT CIRCUIT SECONDARY BEFORE MOVING A CURRENT TRANSFORMER.

Current transformers (CT's) for metering are generally mounted on the stationary primary disconnect studs in the breaker compartment and are readily accessible for inspection and replacement. In some applications they are located in the bus compartment or in the transition section.

When current transformers are mounted in device compartments, care must be exercised when installing or removing transformer mounting screws so as not to strip the holes in the plastic base. Do not torque screws over nine ft/lbs.

### E. Removing Shutter Units

Visual inspection of primary disconnects and CT's can be made by first removing the breaker and opening the shutters manually. This is done by pressing the left and right hand actuating rollers toward the rear of the compartment simultaneously. This is a two-hand operation.

If it is necessary to perform work on the primary disconnects or CT's, it is necessary to remove the entire shutter unit.

# AKD-8 Low-voltage Switchgear

## SECTION VII—Operating the Switchgear

**WARNING:** UNLESS THE PROPER PRECAUTIONS ARE TAKEN, THE REMOVAL OF A SHUTTER UNIT PRESENTS THE HAZARD OF ELECTRICAL SHOCK AND BURN.

DO NOT REMOVE THE SHUTTER UNIT UNLESS THE EQUIPMENT HAS BEEN DE-ENERGIZED.

FAILURE TO DO THIS CAN RESULT IN SERIOUS INJURY.

### E-1. Removing an AKR-30/50 or AKRU-30/50 Shutter Unit

To remove these shutter units, proceed as follows:

1. The shutter unit frame is mounted on the vertical stringers located at each side of the rear of the breaker compartment. See Fig. 7-8.
2. Take out two 1/4-inch hex head screws on each side of the frame. A socket wrench with a 7/16-inch driving head with 4-inch extension will be needed.

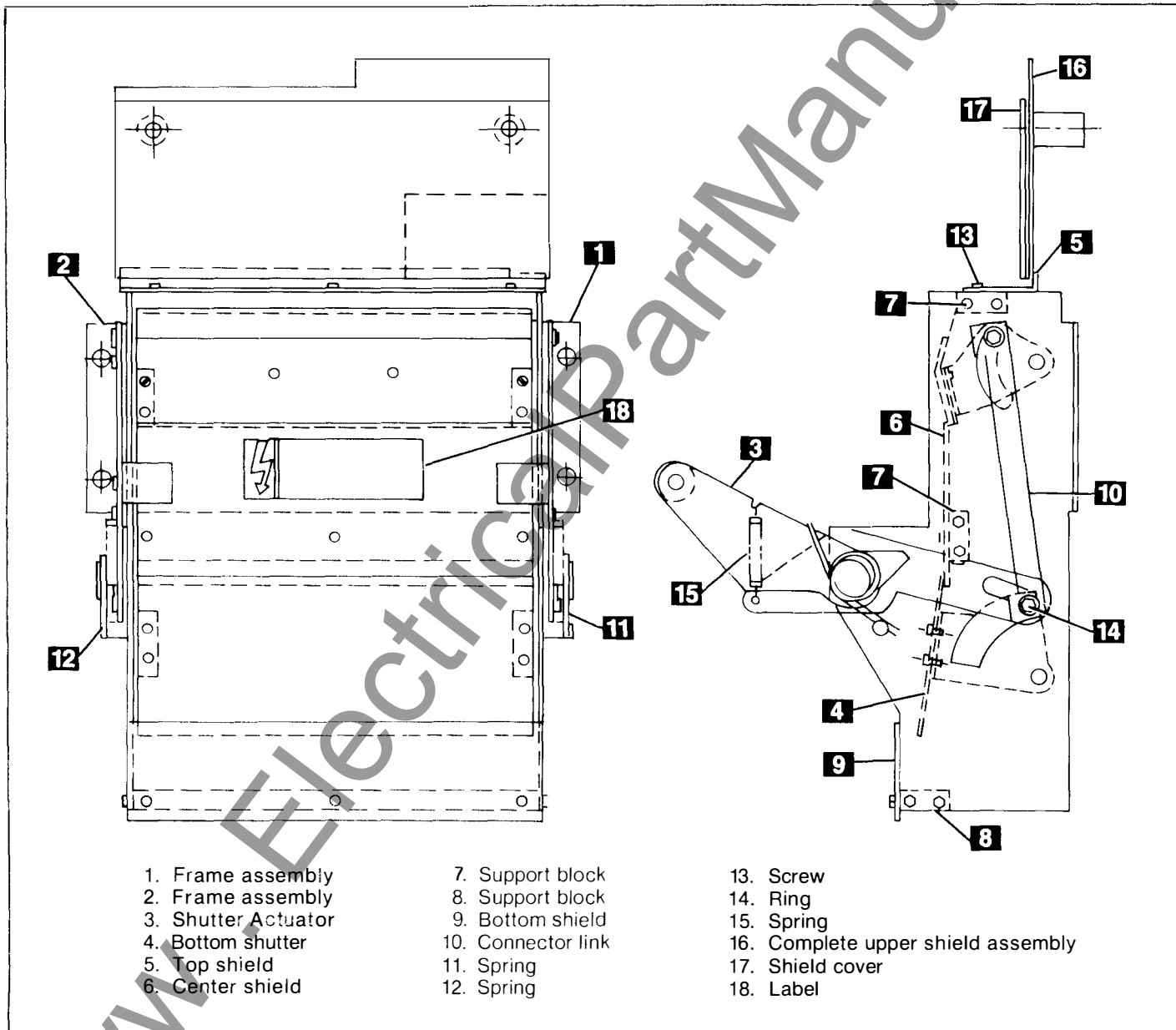

Fig. 7-8. AKD-8 circuit breaker shutter unit (AKR-30/50 breakers)

## SECTION VII—Operating the Switchgear

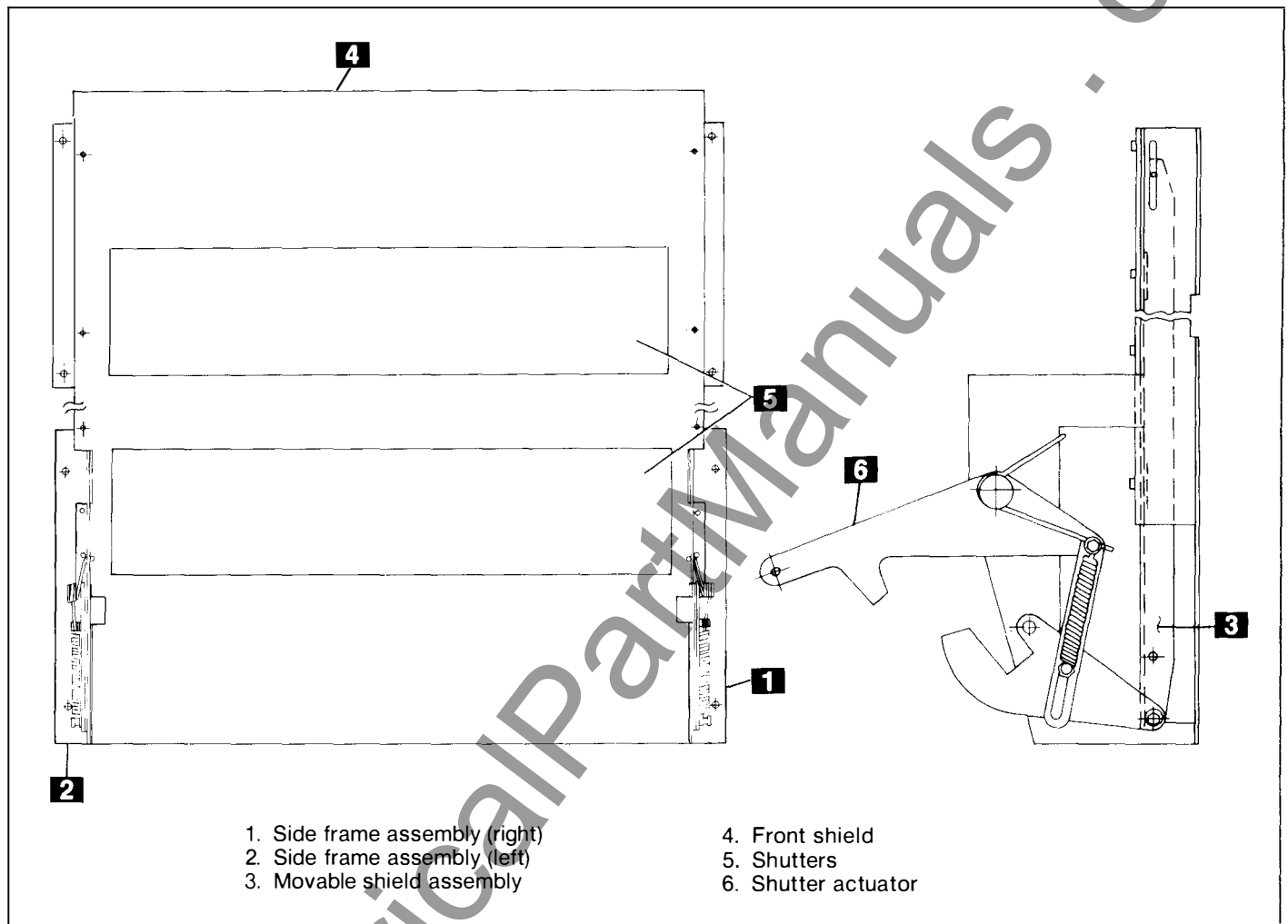

Fig. 7-9. AKD-8 circuit breaker shutter unit (AKR-75/100 breakers)

3. Carefully remove the entire shutter frame. It is necessary to tip the bottom of the frame slightly forward to disengage the flange at the top of the frame from the vertical shield across the top of the rear compartment wall.

4. The frame is then maneuvered forward past the cam plates on each side, then upward and forward over the cam pins.

2. Take out four ¼-inch hex head screws on each side of the frame. A socket wrench with a ⅞-inch driving head with 8-inch extension will be needed. See Fig. 7-9.

3. Carefully remove the entire shutter frame, lifting it slightly to clear the rollout undercarriage.

### E-2. Removing an AKR-75/100 or Fuse Roll Out Shutter Unit

To remove these shutter units, proceed as follows.

1. First, withdraw the drawout undercarriage. The shutter unit frame is mounted to the vertical stringers located at each side of the rear of the breaker compartment.

**NOTE:** If the compartment contains a position switch (Fig. 7-10), it must be moved slightly to allow the frame to be taken out. To do this, remove two ¼-inch hex head screws which hold the position switch mounting bracket to the right stringer of the compartment. It is not necessary to disconnect the wiring. The switch and its bracket can be moved enough to clear the shutter frame as it is removed.

# AKD-8 Low-voltage Switchgear

## SECTION VII—Operating the Switchgear

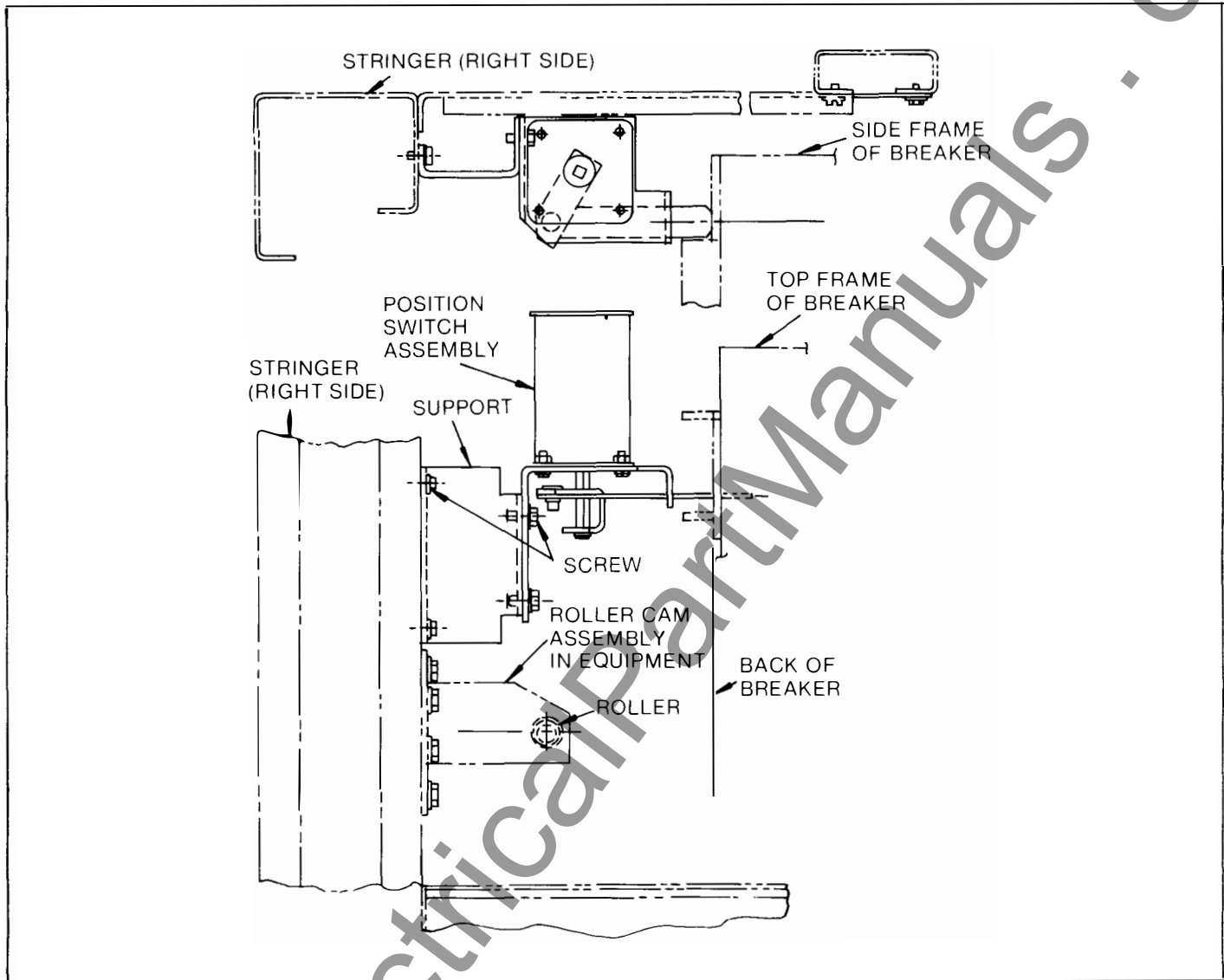

Fig. 7-10. Position switch assembly (AKR-75/100 breakers)

### F. Installing a Shutter Unit

**WARNING:** UNLESS THE PROPER PRECAUTIONS ARE TAKEN, THE INSTALLATION OF A SHUTTER UNIT PRESENTS THE HAZARD OF ELECTRICAL SHOCK AND BURN. DO NOT INSTALL THE SHUTTER UNIT UNLESS THE EQUIPMENT HAS BEEN DE-ENERGIZED. FAILURE TO DO THIS CAN RESULT IN SERIOUS INJURY.

#### F-1. Installing an AKR-30/50 or AKRU-30/50 Shutter Unit

To install these shutter units, proceed as follows:

1. Carefully maneuver the shutter frame into the compartment, first lifting it over the cam pins on each side wall and past the cam plates.
2. Tip the upper edge back so it will slip up behind the vertical shield at the top rear of the compartment.
3. Position the rear flanges of the shutter frame against the vertical stringers at the rear corners of the compartment.

## SECTION VII—Operating the Switchgear

4. Align the holes in the flange and drive in two ¼-inch hex head screws using a 7/16-inch driver with a socket wrench with a 4-inch extension.

5. Check the operation of the moveable shutters by pressing the left and right hand actuating rollers toward the rear of the compartment.

### F-2. Installing an AKR-75/100 Fuse Roll Out Shutter Unit

To install these shutter units, proceed as follows:

1. First, withdraw the drawout undercarriage.

2. Carefully maneuver the shutter frame into the compartment, lifting it slightly to clear the roll out undercarriage.

3. Position the rear flanges of the shutter frame against the vertical stringers at the rear corners of the compartment.

4. Align the holes in the flange and drive in four ¼-inch hex head screws using a 7/16-inch driver with a socket wrench with 8-inch extension.

5. Check the operation of the moveable shutters by pressing the left and right hand actuating rollers toward the rear of the compartment.

---

## SECTION VIII—Energizing the Switchgear

### 8.1—Before Energizing

Before switchgear is energized, a thorough final check should be made using the following checklist:

- Breakers and other operating mechanisms exercised
- Electrical insulation resistance tested phase-to-phase and phase-to-ground
- Relays, meters and instruments properly connected
- Electrically operated breakers and operating mechanisms exercised
- Ground fault protection system tested
- Adjustable trips properly set
- Field wiring secured and free of live bus
- Grounding connections made
- All debris, scrap wire, etc. removed
- All covers installed, doors closed and latched

### 8.2—Energizing

**CAUTION:** ENERGIZING SWITCHGEAR FOR THE FIRST TIME IS POTENTIALLY DANGEROUS. THEREFORE, QUALIFIED ELECTRICAL PERSONNEL SHOULD BE PRESENT WHEN THE EQUIPMENT IS ENERGIZED. IF PROBLEMS CAUSED BY DAMAGE OR POOR INSTALLATION PRACTICES HAVE NOT BEEN DETECTED IN THE CHECKOUT PROCEDURE DESCRIBED PREVIOUSLY, SERIOUS DAMAGE CAN RESULT WHEN POWER IS TURNED ON.

#### A. Energizing Procedures

1. There should be no load on the switchgear when it is energized.

2. Turn off all of the downstream loads, including those such as motor control centers and other devices which are remote from the switchgear.

3. The equipment should be energized in sequence by starting at the source end of the system and working toward the load end. In other words, energize the main devices, then the feeder devices, and then the branch-circuit devices.

4. Turn the devices on with a firm positive motion.

# AKD-8 Low-voltage Switchgear

## SECTION IX—Maintaining the Switchgear

### 9.1—Maintenance Requirements

#### A. General

A periodic maintenance schedule must be established to obtain the best service from the switchgear. An annual check should be made and over-all maintenance procedures for the switchgear devices and all connections should be followed as a minimum requirement. Equipment subject to highly repetitive operation may require more frequent maintenance.

A permanent record of all maintenance work should be kept. The record should include a list of periodic checks and tests made, the date they were made, the condition of the equipment, and any repairs or adjustments that were performed. Maintenance employees must follow all recognized safety practices, such as those contained in the National Electric Safety Code ANSI C2-1981 and in company or other safety regulations during the maintenance.

**WARNING:** SOLID INSULATION SURROUNDING AN ENERGIZED CONDUCTOR AND POWER APPARATUS MUST NEVER BE RELIED UPON TO PROVIDE PROTECTION TO PERSONNEL.

For specific information regarding the maintenance of devices, such as circuit breakers, relays, meters, etc., refer to the separate instruction book furnished for each device.

### 9.2—Breaker and Instrument Compartments

Periodic inspection of the circuit breaker is recommended at least once a year. More frequent inspections are recommended where severe load conditions, dust, moisture or other unfavorable conditions exist, or if the vital nature of the load warrants it.

Always inspect the breaker after a short-circuit current has been interrupted.

#### A. Breakers

##### A-1. Test for Proper Operation

Test and inspect all circuit breakers for proper operation as follows:

1. Operate each breaker while in the TEST position and check all functions. This is particularly important for breakers that normally remain in either the opened or closed positions for long periods of time.

**WARNING:** PRIMARY EQUIPMENT MUST BE COMPLETELY DE-ENERGIZED WHILE TESTS ON CONTROL CIRCUITS, ETC. ARE BEING CONDUCTED. BE SURE THAT ALL AREAS OF FEED-BACK FROM SECONDARY CIRCUITS, AS WELL AS OUTSIDE SOURCES, ARE DISCONNECTED.

2. Remove the breakers from their compartments to a clean maintenance area. Close the compartment door and cover the breaker cutout to prevent access to live parts.

**WARNING:** DE-ENERGIZE EQUIPMENT COMPLETELY BEFORE DOING MAINTENANCE WORK ON ANY DEVICES, CONNECTIONS, BUS WORK, BREAKER OR FEEDER CABLE COMPARTMENTS. THIS INCLUDES DE-ENERGIZING ANY CONNECTIONS TO OUTSIDE PRIMARY OR SECONDARY SOURCES, SUCH AS TRANSFORMERS, TIE LINES, ETC.

##### A-2. Checks After Breaker Is De-energized

At the time of inspection, the following checks should be made after the breaker has been de-energized.

1. Manually operate the breaker several times, checking for obstructions or excessive friction. Manual closing of an electrically operated breaker may be performed by the following two steps:
  - a. Install maintenance crank (568B386G1) to the motor gear reducer shaft on the front right side of the breaker. Ratchet the maintenance crank up and down until the springs are fully charged as indicated by the distinct click as the prop is set which prevents any further charging of the closing springs. After the prop is set, do not apply undue force to the maintenance handle.
  - b. On AKR-75 and AKR-100 breakers depress the SPRING DISCHARGE lever located under the horizontal support on the front frame. The springs should discharge and, if the latch is properly reset, the breaker will close.
2. Electrically operate the breaker several times to check performance of the electrical accessories.
3. Visually check the breaker for loose hardware on the breaker; also, check the bottom of the compartment for any hardware that has fallen from the breaker.
4. Remove the arc quenchers and inspect the arc quenchers and contacts for breakage or excessive burning.
5. The performance of the solid-state current trip devices may be checked with a suitable test set. Check electromechanical devices for positive trip in accordance with the instructions in the proper Maintenance Manual.
6. Check insulating parts for evidence of overheating and for cracks that indicate excessive thermal aging.

Refer to circuit breaker instruction manuals for detailed maintenance instructions and information for replacement of parts.

## SECTION IX—Maintaining the Switchgear

### A-3. Lubrication

In general, the circuit breaker requires moderate lubrication. Bearing points and sliding surfaces should be lubricated at the regular inspection periods with a thin film of GE lubricant D50HD38 (Mobil 28). Before lubricating, remove any hardened grease and dirt from latch and bearing surfaces with kerosene.

**CAUTION:** ALL EXCESS LUBRICANT SHOULD BE REMOVED WITH A CLEAN CLOTH TO AVOID ACCUMULATION OF DIRT OR DUST.

On drawout breakers, the contact surface of the disconnect fingers should be cleaned and greased with GE lubricant D50HD38.

### B. Instruments, Instrument Transformers, and Relays

Check and inspect all devices to see that they are functioning properly. Check that all electrical connections are tight. Check mounting of the device.

Under normal conditions, the protective relays do not operate; therefore, it is important to check the operation of these devices regularly. Refer to Relay Instruction Books for detailed instructions.

### C. Breaker Compartment Interiors

**WARNING:** DE-ENERGIZE EQUIPMENT COMPLETELY BEFORE DOING MAINTENANCE WORK IN COMPARTMENTS. THIS INCLUDES DE-ENERGIZING ANY CONNECTIONS TO OUTSIDE PRIMARY OR SECONDARY SOURCES, SUCH AS TRANSFORMERS, TIE LINES, ETC.

1. Thoroughly clean the interior of the breaker and instrument compartments. Use a vacuum cleaner and clean rags only. Do not use steel wool or oxide papers. Blowing with compressed air is not recommended.

2. Check indicating devices, mechanical and key interlocks.

3. Check primary disconnecting device contacts for signs of abnormal wear or overheating. Discoloration of the silvered surfaces is not ordinarily harmful. These contacts should be cleaned only by wiping with a lint-free cloth.

4. Clean the racking mechanism and lubricate with lubricant D50HD38 (Mobil 28).

5. Before replacing the breaker, wipe off the primary disconnecting device contacts. Apply a thin coat of contact lubricant D50H47 to the stationary studs and to the primary disconnects on the breaker.

### 9.3—Bus Area

Inspect and check the bus area as follows:

1. Inspect the buses and connections carefully for evidence of overheating or weakening of the insulating supports.
  - a. If bus insulation is present, remove the molded covers over the main bus connection to expose joints for inspection.
2. Check all connection bolts in the bus compartment and all bracing bolts for tightness. See the Torque Table A-1 in Appendix A.
3. Vacuum and, with a clean rag, wipe the buses and supports.
4. Visually inspect the insulation on the bars that run from the breaker studs through the bus structure to the cable area.
5. After cleaning, megger and record the resistance to ground and between phases of all insulated bars and all buses and connections. Disconnect all control circuits before checking resistance. Do not use over a 1500-volt megger. Since definite limits cannot be given for satisfactory insulation resistance values, a record must be kept of the readings.

Weakening of the insulation from one maintenance period to the next can be recognized from the recorded readings. The readings should be taken under similar conditions each time, if possible, and the record should include the ambient temperature and humidity.

### 9.4—Cable and Busway Compartment

Inspect and check the cable and busway compartment as follows:

1. Inspect all power cable connections for signs of overheating and tighten all connections. If severe discoloration or if damage is apparent, remove the damaged portion of the cable.

**CAUTION:** BE SURE THE CONDITION WHICH CAUSED THE OVERHEATING HAS BEEN CORRECTED BEFORE ENERGIZING.

2. Check all bolts that hold cable terminals to the connection bars for tightness.
3. Check the neutral bus and ground bus connection and mounting bolts for tightness.
4. Check that all secondary control wiring connections are tight and that all control cabling is intact.

# AKD-8 Low-voltage Switchgear

## SECTION IX—Maintaining the Switchgear

### 9.5—Over-all Switchgear

Make the following checks on the complete switchgear equipment.

1. Clean and inspect all painted surfaces and retouch where necessary.
2. Check to see that all anchor bolts and other structural bolts are tight.
3. Check that all breaker and instrument compartment door latches operate properly.
4. If the switchgear is equipped with heaters, check to see that all heaters are energized and operating.
5. For exterior vent openings in equipment furnished with air filters, the foam filter elements should be removed and washed in warm soapy water, rinsed, and reassembled at least annually. Elements should be inspected before reassembly and replaced if any signs of deterioration are evident.

### 9.6—Paint Refinishing

Indoor switchgear is finished with ANSI-61 gray polyester paint, which is applied with an electrostatic spray system and

is oven baked. To refinish damaged areas, remove all loose paint, rust, scale, oil or grease. Sand any scratches smooth. Apply ANSI-61 Gray Glidden semi-gloss vinyl acrylic, Cat. 439-E-2102, using a spray can supplied by the factory for touch-up purposes.

Outdoor switchgear is finished with an additional coat of ANSI-61 gray paint over the baked finish. The final coat is ANSI-61 Gray Glidden semi-gloss vinyl acrylic, Cat. 439-E-2102. To refinish damaged areas, remove all loose paint, rust, scale, oil, or grease. Sand any scratches smooth. Spray with ANSI-61 Gray Glidden semi-gloss vinyl acrylic, Cat. 439-E-2102, using spray cans supplied by the factory.

### 9.7—Circuit Breaker Lifting Mechanism

Under normal conditions, no special maintenance procedures or lubrication is required for this device. If the cable is abraded under any condition, it should be inspected for broken strands or other damage and replaced if necessary.

## APPENDIX A—Torque Values

**Table A-1—Torque Values for Low-voltage Equipment Electrical Joint Hardware other than Cable Terminals (Copper or Aluminum)**

Hardware Size	Torque* (ft/lbs) Standard Nut with Conical Spring Washer or Lockwasher
¼-20	7-9
⅜-16	25-30
½-13	35-40
⅝-11	40-45

\*These torque values are for non-lubricated threads

**Table A-2—Torque Values for Self-threading Screws in Plastic**

Caution should be exercised when installing parts or components to the compartment molded base. Torque ¼-inch screws slowly and do not exceed nine ft/lbs.

**Table A-3—Torque Values for Cable Terminals**

Wire Size	Torque* (ft-lbs)
6	8
5	
4	
3	
3	10
2	
1	
0	12
00	
000	17
0000	
200,000	
250,000	
300,000	21
350,000	
400,000	
500,000	
600,000	25
700,000	
750,000	
800,000	
900,000	33
1,000,000	
1,250,000	
1,500,000	42
1,750,000	
2,000,000	
2,000,000	

\*These torque values are for non-lubricated threads.

## APPENDIX B—Circuit Breaker Rejection Features

### B.1—General

In general, drawout breakers of the same type and rating are interchangeable in their equipment compartments; drawout breakers of different frame sizes or short circuit ratings are intentionally made non-interchangeable. To prevent inserting the wrong type breaker into a drawout compartment, unique "rejection hardware" is affixed to each breaker and its compartment. Two different mountings of rejection hardware used: one for those breakers mounted in 22-inch wide compartments (AKR-30/50 family) and the other for those breakers mounted in 30-inch wide compartments (AKR-75/100 family). The different types of rejection hardware are required due to different drawout mechanisms used for the two breaker families.

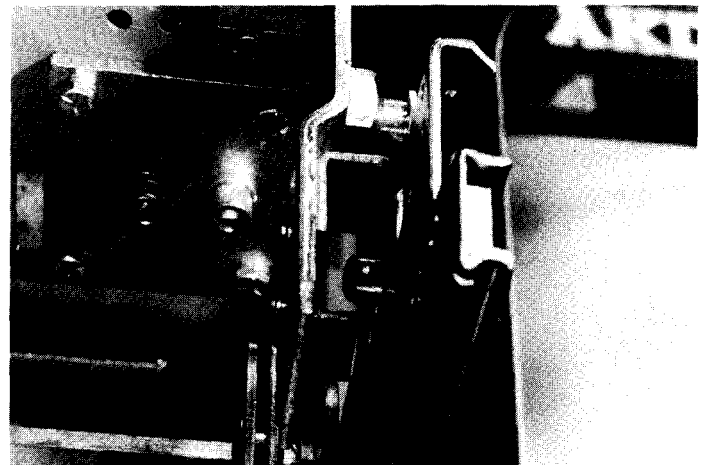

Fig. B-1. Breaker-mounted rejection bracket

# AKD-8 Low-voltage Switchgear

## APPENDIX B—Circuit Breaker Rejection Features

### B-1A. 22-Inch Wide Compartment

Figure B-1 (AKR-30/50 breaker family) shows the breaker-mounted rejection bracket and its uniquely located slot.

This slot (one in each side of the breaker) must align with a rejection pin uniquely located on the drawout rail, one on each rail.

When the wrong type breaker is inserted into a compartment, the bracket and pin do not mate, preventing the breaker from seating itself into the rail slots.

There is one exception to the above rule. Breakers of the same frame size, having different short circuit ratings, may be interchanged in one direction only. Specifically:

1. An AKR-30H can be inserted into an AKR-30 compartment.

2. An AKR-50H can be inserted into an AKR-50 compartment.

The rejection hardware prevents the converse of 1. and 2.

Figures B-2 and B-3 show the rejection pin/bracket combinations employed for the various breaker models and frame sizes. As dictated by its intended breaker type, each drawout compartment has its rejection pin(s) installed in positions A, B or C (Figs. B-2 and B-3) along the drawout rails. The AKRU-30/50 fused breakers employ a single bracket while all non-fused breakers employ two brackets.

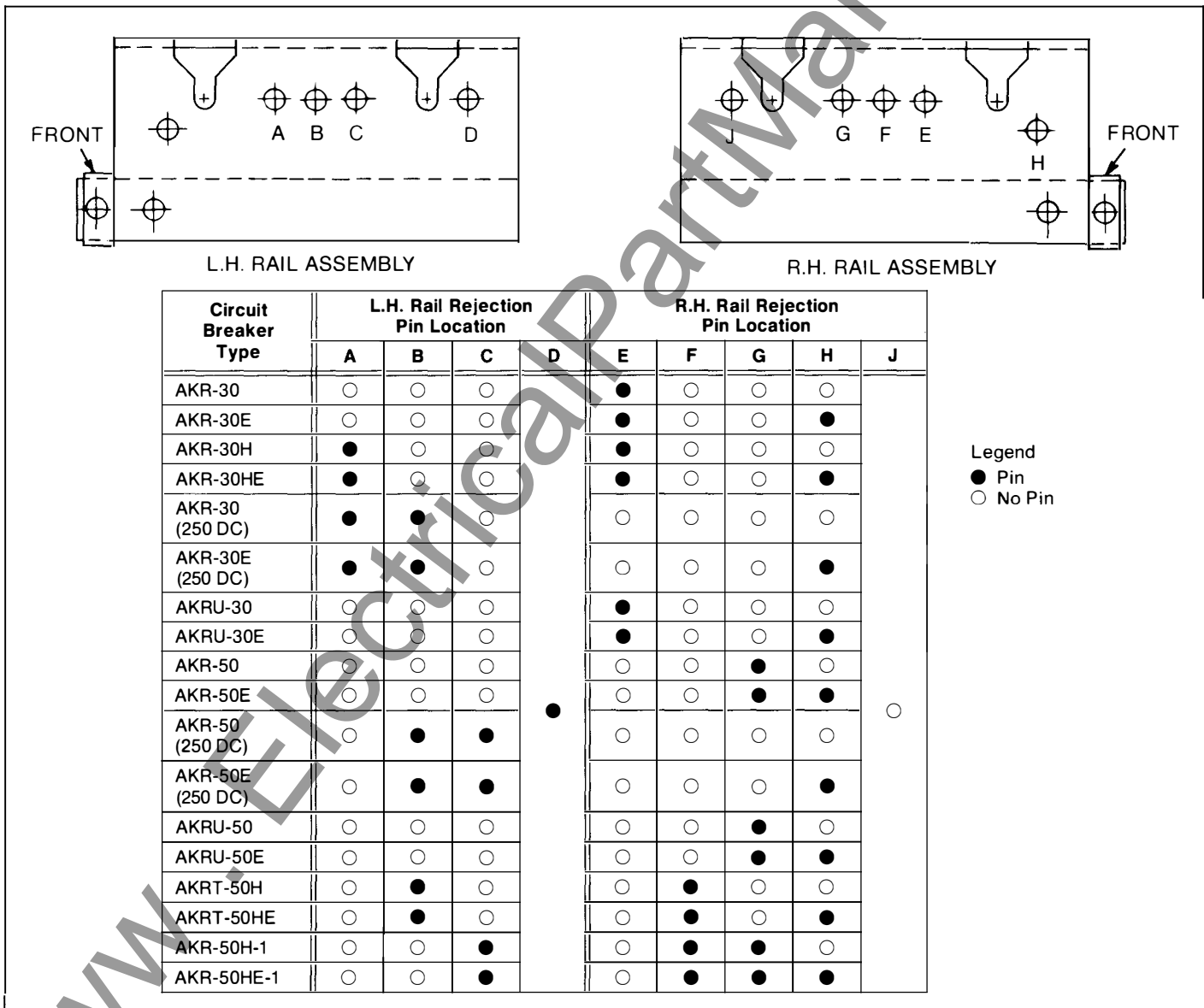

Fig. B-2. Rejection pin pattern code for AKR-30/50 main breakers

# APPENDIX B—Circuit Breaker Rejection Features

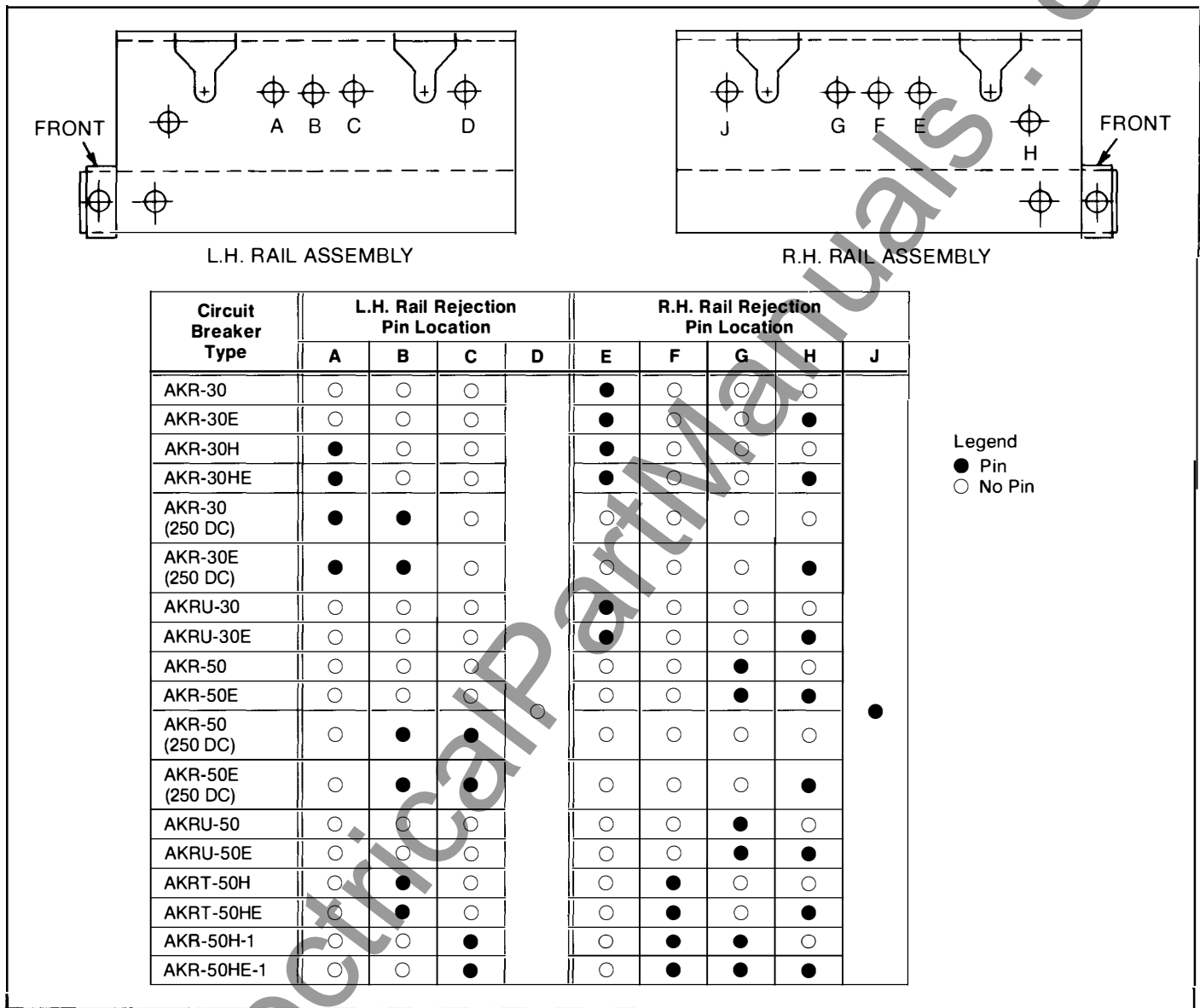

Fig. B-3. Rejection pin pattern code for AKR-30/50 feeder breakers

Some installations require that breakers serving essential circuits be segregated from identical models deployed elsewhere in the power system. The segregation is physical and is accomplished by supplemental rejection hardware added to the breaker and its drawout compartment.

In this publication, these special category breakers are designed as "E-type." They are interchangeable as follows:

- E-type compartments reject standard breakers
- Standard compartments accept E-type breakers.

E-type rejection is an optional feature available on both A and B-type breakers. It is achieved by installing an extra pin in the right-hand slide rail (H location) which engages an additional notch in the breaker's rejection bracket. See Figs. B-2 and B-3.

# AKD-8 Low-voltage Switchgear

## APPENDIX B—Circuit Breaker Rejection Features

### B-1B. 30-Inch Wide Compartment

Like the AKR-30/50 breaker family, AKR-75/100 breakers for AKD-8 switchgear height and width also must include means to prevent inadvertent interchange of these 3200- and 4000-ampere sizes. This is done by adding interference hardware to each breaker and its compartment, causing the compartment to accept the correct breaker type and reject all others.

However, due to the difference in drawout mechanisms, the hardware to provide the rejection features differs from that for AKR-30/50 breakers.

Interchangeability within and between frame sizes is prevented by the rejection system of Fig. B-4. Various positioned pins on the drawout tray must align with matching

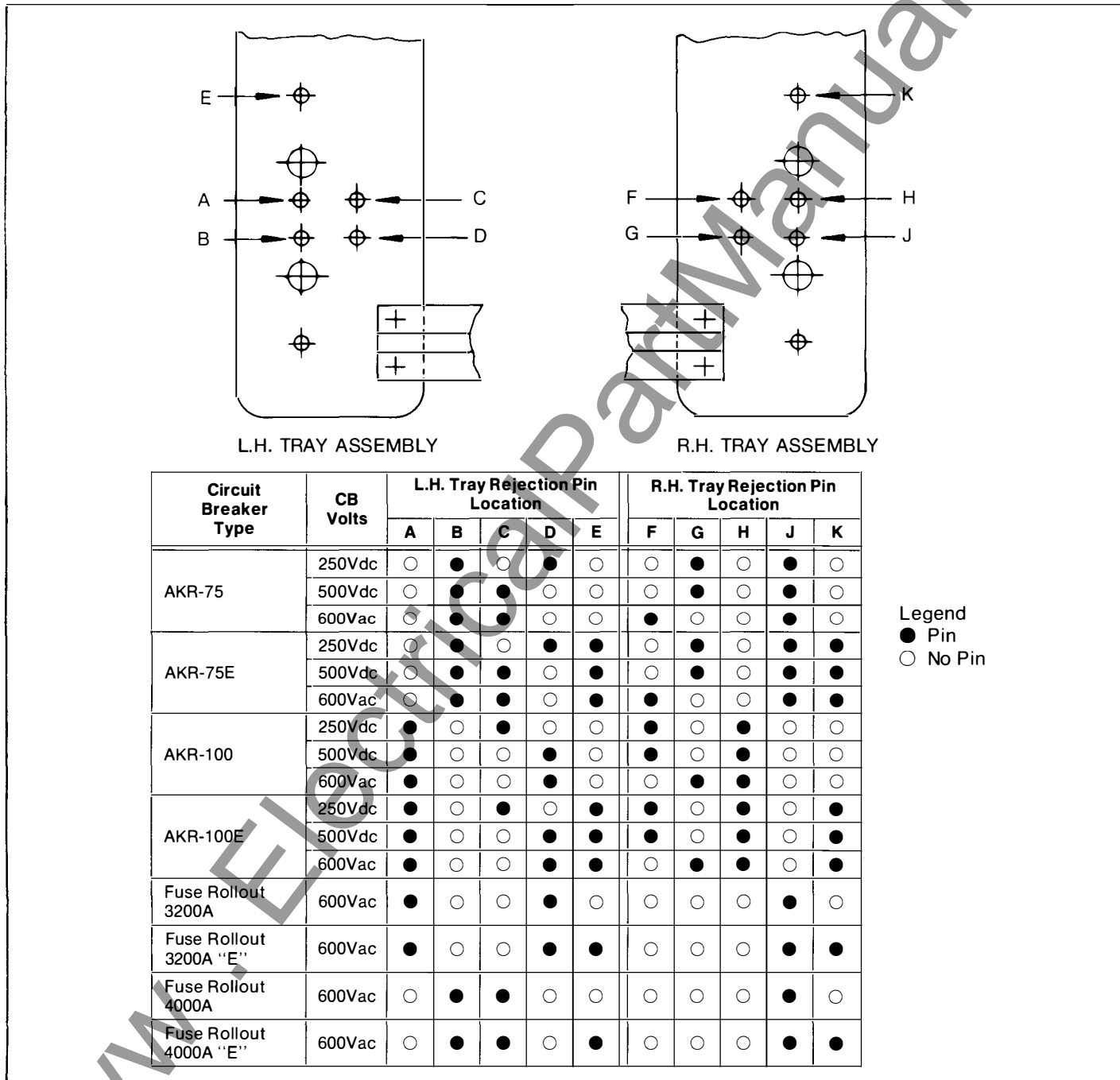

Fig. B-4. Rejection pin pattern code for AKR-75/100 breakers and FRO

## APPENDIX B—Circuit Breaker Rejection Features

holes and notches in rejection plates bolted to the breaker's bottom flanges. An incorrect style breaker presents a mismatch and will not seat on the tray. Figure B-5 shows the location of the rejection pins on the drawout tray.

E-type rejection, as previously described for AKR-30/50 breakers, is achieved by notching the breaker's right side plate to clear a special rejection pin added to the right slide rail.

### B-2. Fuse Rollout Elements

Fuse rollout (FRO) elements to be used in conjunction with either the AKR-75 (3200 ampere) or AKR-100 (4000 ampere) breakers employ the same type drawout mechanism as its companion breaker and utilize the same type rejection system. Only a 3200-ampere fuse rollout element may be installed in a 3200-ampere fuse rollout compartment; likewise only a 4000-ampere fuse rollout element may be installed in a 4000-ampere fuse rollout compartment. The rejection pin pattern is shown on Fig. B-4.

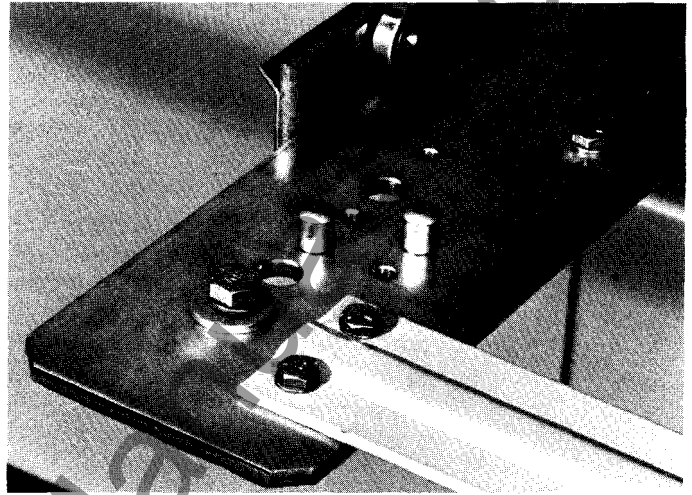

Fig. B-5. View showing location of rejection pins on drawout tray

## APPENDIX C—Circuit Breaker Ratings

Table C-1—General Circuit Breaker Ratings

Frame Size (Amperes)	Breaker Type	System Nominal Voltage 60 Hz, Ac	Three-phase Short Circuit Rating RMS Symmetrical Ka	
			With Instantaneous Trip	Without Instantaneous Trip
800	AKR-30	600	30	30
		480	30	30
		240	42	30
800	AKR-30H	600	42	42
		480	42	42
		240	50	42
1600	AKR-50	600	42	42
		480	50	50
		240	65	50
1600	AKR-50H-1	600	65	65
		480	65	65
		240	65	65
2000	AKRT-50H	600	65	65
		480	65	65
		240	65	50
3000 } 3200 }	AKR-75	600	65	65
		480	65	65
		240	85	65
4000	AKR-100	600	85	85
		480	85	85
		240	130	85

\*Short time current ratings

# AKD-8 Low-voltage Switchgear

## APPENDIX C—Circuit Breaker Ratings

**Table C-2—Integrally Fused Circuit Breaker Ratings**

Frame Size (Amperes)	Breaker Type	Rated Maximum Voltage 60 Hz, A-c	CLF Fuse Rating (Amperes)		Interrupting Rating RMS Symmetrical Ka
			Min	Max	
800	AKRU-30	600	300	1600	200
1600	AKRU-50	600	450	2500	200

**Table C-3—Circuit Breaker Control-operating Currents**

Mode	Rated Voltage	Voltage Range	Amperes Inrush/Sustained		
			AKR-30/50 AKRT-50	AKR-75/100	
Closing	Ac 60 Hz	{ 120 240	104-127 208-254	25/5 12/3	25/8.1 12/3.5
	Dc	{ 125 250	100-140 200-280	27/5 13/3	27/7 13/3.2
	Tripping	Ac 60 Hz	{ 120 240	95-127 190-254	12.3/10.8 3.9/3.4
Dc		{ 125 250	70-140 140-280	1.9/1.9 1.0/1.0	

## APPENDIX D—Circuit Breaker Accessory Device Ratings

### Shunt Trip

The shunt trip offers remote electrical tripping of breakers. Usually controlled by a switch or push button, it may also be used in conjunction with protective relays for automatic tripping.

The shunt trip coil is rated for intermittent duty. When ordered factory installed, it is supplied with a cutoff switch which automatically removes control power following a breaker trip. See Table D-1.

**Table D-1**

Control Voltage		Shunt Trip Amperes		
Nominal	Operating Range	Inrush	Sustained	
Dc	48	28-60	4.5	4.5
	125	70-140	1.9	1.9
	250	140-280	1.0	1.0
60 Hz Ac	120	95-127	12.3	10.8
	208	175-220	3.2	2.6
	240	190-254	3.9	3.4
480	575	380-508	3.4	3.1
		475-625	2.8	2.5

### Undervoltage Trip (UV)

The undervoltage trip device protects against harmful drops in line voltage by automatically tripping the breaker. This device is set to pick up at approximately 80 percent of bus voltage and drop out between 30 percent and 60 percent. See Table D-2.

**Table D-2**

Control Voltage		UV Coil Amperes	
		Inrush	Sustained
Dc	48	0.20	0.20
	125	0.07	0.07
	250	0.04	0.04
60 Hz Ac	120	0.66	0.24
	208	0.51	0.17
	240	0.37	0.12
	480	0.23	0.08
50 Hz Ac	120	0.75	0.25
	208	0.30	0.10
	240	0.34	0.11
	480	0.17	0.07

# APPENDIX D—Circuit Breaker Accessory Device Ratings







The UV device is also available with an optional static time-delay unit. This offers a field adjustable 2- to 6-second delay between undervoltage fault and breaker trip to prevent potential nuisance tripping due to momentary loss of voltage.

The time-delay unit is mounted external to the breaker. It is rated 125 or 250 volts dc or 208/240 volts ac, 50 or 60 hertz. For any other ac source voltage, a control power transformer with a 240-volt secondary rated at least 100 Va is required.

## Auxiliary Switch

The auxiliary switch is used for remote indication of breaker main contact position and is available in groupings of four contacts (two stages) or ten contacts (five stages). Each stage is composed of one "A"-Type (N.O.) contact and one "B"-Type (N.C.) contact. All contacts feature rugged double break construction. See Tables D-3 and 4.

**Table D-3**

CB Main Contacts	Auxiliary Switch Position	
	"A" Contact	"B" Contact
Open or Tripped 	Open 	Closed 
Closed 	Closed 	Open 

**Table D-4**

Control Voltage		Auxiliary Switch Interrupting Ratings (Amperes)	
		Non-inductive	Inductive
Dc	125	11*	6.3*
	250	2	1.8
Ac 60 Hz	115	75*	50*
	240	50*	25*
	480	25*	12*

\*Limited to 20 ampere continuous rating of switch on all breakers and to 5-ampere continuous rating of No. 16 wire on drawout breakers.

## Remote Close Solenoid—

### For Manually Operated Type AKR-30/50 Breakers

This solenoid provides a means to electrically close the AKR-30/50 breakers from a remote location. It may be controlled

by a switch or push button for five-cycle closing. The breaker must be charged locally. The available ratings are shown in Table D-5.

**Table D-5**

Control Voltage		Amperes	
		Inrush	Sustained
Dc	48	2.7	2.7
	125	1.3	1.3
	250	0.68	0.68
60 Hz Ac	120	2.6	0.4
	240	1.3	0.2

## Bell Alarm With Lockout

The bell alarm operates one "A" and one "B" contact or two A's or two B's. It is activated when the breaker is tripped by any (automatic) means other than the manual trip button or the shunt trip device. The ratings are shown in Table D-6.

The contacts may be used for remote indication of an automatic trip.

The lockout feature is available to mechanically lock the breaker "open" when the device is activated. "Reset" is accomplished through operation of manual trip button or shunt trip device.

The bell alarm is available without the lockout feature when so specified.

**Table D-6**

Control Voltage		Bell Alarm Contact Ratings (Amperes)	
		Inrush	Continuous
Dc	125	2.5	2.5
	250	0.9	0.9
60 Hz Ac	115	30	10
	230	15	5
	460	7	3

## Electric Lockout

The electric lockout device provides a means of electrically interlocking breakers so that two cannot be closed at the same time. This electro-mechanical device consists of a coil whose winding must be energized to close the breaker. Once the breaker is closed, loss of voltage will not trip the breaker. A bypass interlock is provided for initial start-up. Refer to the UV device for ratings and coil characteristics.

Auxiliary switches for cross-interlocking breakers must be ordered separately.

# AKD-8 Low-voltage Switchgear

## APPENDIX E—Circuit Breaker Weights

**Table E-1—Average Weight (Pounds)**

Device	Net Weight		Shipping Weight	
	Manual	Electrical	Manual	Electrical
AKR-30	200	205	225	230
AKR-30H	200	205	225	230
AKRU-30	245	250	275	280
AKR-50	210	215	235	240
AKR-50H	210	215	235	240
AKRU-50	255	260	285	290
AKRT-50H	215	220	240	245
AKR-75	420	435	470	485
AKR-100	525	560	575	590
2000-Ampere Fuse Rollout	250		300	
3200-Ampere Fuse Rollout	350		400	
4000-Ampere Fuse Rollout	400		450	

## APPENDIX F—Circuit Breaker Repetitive Duty Data

### General

Circuit breakers are designed primarily to perform the function of circuit interruption under short-circuit conditions. Nevertheless modern circuit breaker mechanisms are capable of many operations under full-load operation and in-rush

conditions such as encountered in motor starting applications. Industry standards have been established for the minimum performance which is indicated in Table F-1. With adequate maintenance, GE breakers can be expected to exceed the standards.

**Table F-1—Repetitive Duty and Normal Maintenance**

Circuit Breaker Frame Size (Amperes)	Number of Operations Between Servicing	Number of Operations Rated Continuous Current Switching* (A) (C) (D) (E) (F) (G) (H) and (J)	Number of Operations No-Load Closing and Opening* (A) (B) (C) (D) (E) (F) and (G)	Number of Operations In-Rush Current Switching* (C) (D) (E) (F) (G) (I) and (J)
225	2500	4000	10000	2000
800	1750	2800	9700	1400
1600	500	800	3200	400
2000	500	800	3200	400
3200	250	400	1100	—
4000	250	400	1100	—

\*Refer to lettered paragraphs under NOTES.

### Notes

Power operated circuit breakers, when operating under usual service conditions, shall be capable of operating the number of times specified in Table F-1. The operating condi-

tions and the permissible effect of such operations upon the breaker are given in the following lettered paragraphs. For each column, all paragraphs listed in the column heading must be given consideration.

## APPENDIX F—Circuit Breaker Repetitive Duty Data

This standard applies to all parts of a circuit breaker that function during normal operation. It does not apply to other parts, such as overcurrent tripping devices, that function only during infrequent abnormal circuit conditions.

- (A) Servicing consists of adjusting, cleaning, lubricating, tightening, etc., as recommended by the manufacturer. When current is interrupted, dressing of contacts may be required as well. The operations listed are on the basis of servicing at intervals of 6 months or less.
- (B) When closing and opening no-load.
- (C) With rated control voltage applied.
- (D) Frequency of operation not to exceed 20 in 10 minutes or 30 in an hour. Rectifiers or other auxiliary devices may further limit the frequency of operation.
- (E) Servicing at no greater intervals than shown in Column 2 of Table F-1.
- (F) No functional parts should have been replaced during the listed operations.
- (G) The circuit breaker should be in a condition to carry its rated continuous current at rated maximum voltage and perform at least one opening operation at rated short-

circuit current. After completion of this series of operations, functional part replacement and general servicing may be necessary.

- (H) When closing and opening current up to the continuous current rating of the circuit breaker at voltages up to the rated maximum voltage and at 85% of the power factor or higher.
- (I) When closing currents up to 600% and opening currents up to 100% (80% power factor or higher) of the continuous current rating of the circuit breaker at voltages up to the rated maximum voltage.

When closing currents up to 600% and opening currents up to 600% (50% power factor or less) of the continuous current rating of the circuit breaker at voltages up to rated maximum voltage, the number of operations shown shall be reduced to 10% of the number listed.

- (J) If a fault operation occurs before the completion of the listed operations, servicing is recommended and possible functional part replacements may be necessary, depending on previous accumulated duty, fault magnitude, and expected future operations.

## APPENDIX G—Fuses for AKRU-30/50 and FRO Elements

Table G-1—Fuses for Integrally Fused AKRU Breakers

NEMA Fuse Class 600V, 60 Hz	Breaker Type AKRU		Ampere Rating	GE CLF Fuses		Gould Shawmut Fuse Cat. No.
	30	50		Cat. No.	Time Current Curves	
"J"	x	—	300*	GF8B300	GES-8004	A4J300
	x	—	350*	350	"	A4J350
	x	—	400*	400	"	A4J400
	x	x	450	450	"	A4J450
	x	x	500	500	"	A4J500
	x	x	600	600	"	A4J600
"L"	x	x	800	800	GES-8005	A4BY800
	x	x	1000	1000	"	A4BY1000BG
	x	x	1200	1200	"	A4BY1200BG
	x	x	1600	1600	"	A4BY1600BG
	—	x	2000	2000	"	A4BY2000BG
Special	—	x	2500	GF9F200AK	183B7832	A4BX2500GE

\*Mounting adapter required.

Table G-2—Fuses for Roll-out Fuse Carriages

Fuse Carriage	Fuse Size		Fuse Cat. No.'s.	
	Min.	Max.	GE CLF	Gould Shawmut
3200	2000A	3000A	GF8B2000	A4BY2000
4000	2000A	4000A	GF8B3000	A4BY3000
			GF8B4000	A4BY4000

**Notes**

www . ElectricalPartManuals . com

**Notes**

[www.ElectricalPartManuals.com](http://www.ElectricalPartManuals.com)

www.ElectricalPartManuals.com

These instructions do not purport to cover all details or variations in equipment nor to provide for every possible contingency to be met in connection with installation operation or maintenance. Should further information be desired or should particular problems arise which are not covered sufficiently for the purchaser's purposes, the matter should be referred to the General Electric Company. These instructions are intended for use by qualified personnel only.

---

For further information  
call or write your local  
General Electric  
Sales Office or . . .

General Electric Co.  
Distribution Equipment  
41 Woodford Avenue  
Plainville, CT 06062, USA

---