

**HV single phase  
SF6  
gas insulated  
switchgear**

**type Hexabloc  
245 - 300 kV**

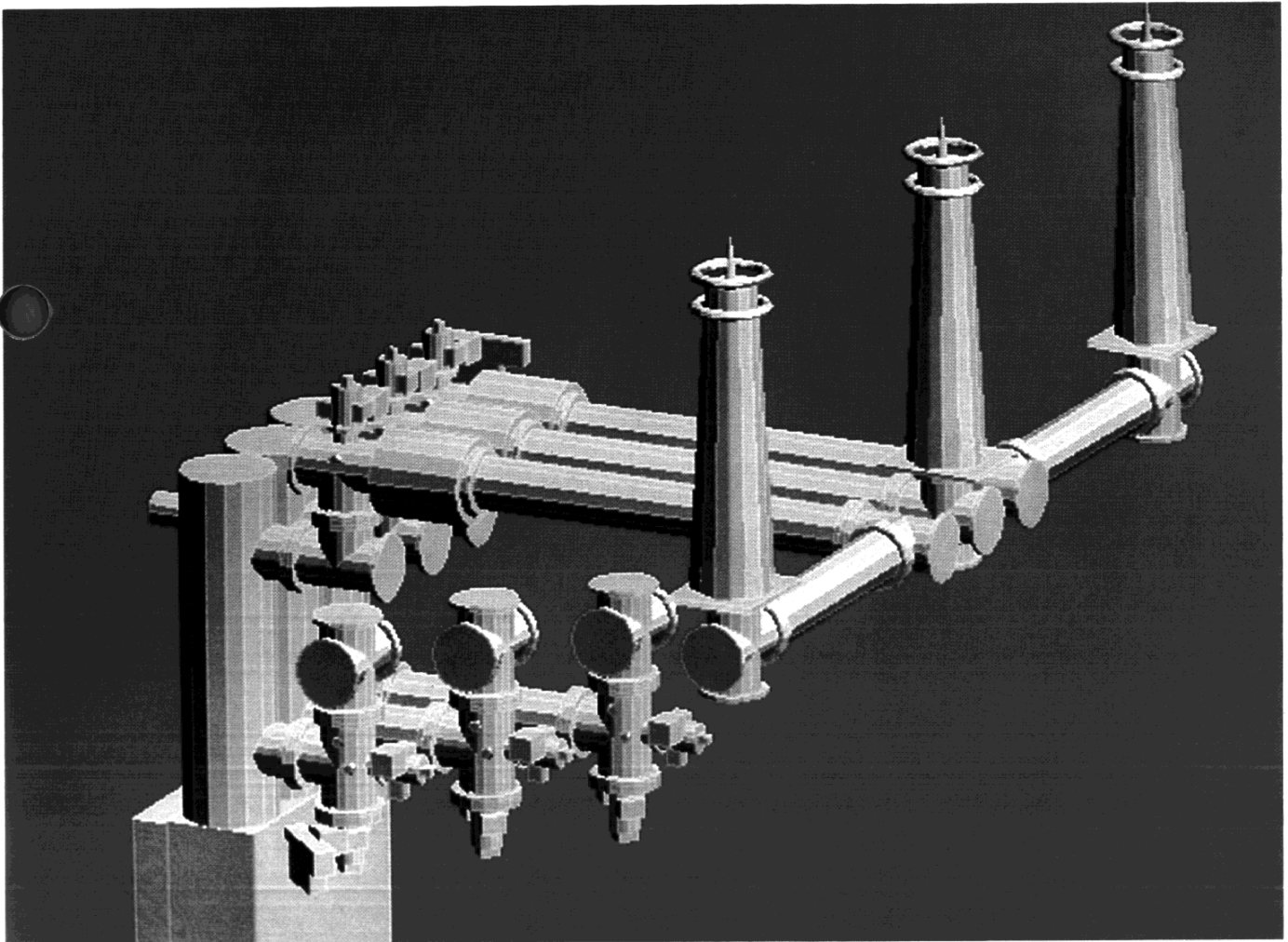

# introduction

The increasing demand for electrical energy in big cities and industrial areas has made it necessary to bring EHV systems right to the doorstep of load centres.

This has led Merlin Gerin towards the development of a range of SF6 gas insulated HEXABLOC switchgear. Hexabloc H9S is designed for substations with a rated voltage between 245 and 300 kV.

Thanks to the choice of technical options and the technology used, Hexabloc achieves the following objectives :

- high safety
- very high reliability
- insensitivity to pollution
- compact size
- outdoor or indoor installation
- elimination of harmful effects
- ease of transport, installation and operation
- reduced maintenance.

It ensures :

With gas insulated switchgear (GIS) all foreign bodies (persons, animals, tools) are prevented from coming into contact with live parts.

#### Very high reliability

Due to great attention to detail and strict quality control at all stages of manufacture.

#### Insensitivity to pollution

All live parts are totally protected from atmospheric pollution (fog, salt, sand,...) or industrial pollution (dust, smoke, gas,...).

#### Large reduction in size

Using SF6 gas as a dielectric medium reduces insulation distances. For a given layout, GIS is much more compact than the conventional «open» type.

The relation between the surface areas of the two types of construction can be expressed as follows :

- Conventional substation : 100
- Hexabloc : 10 to 15.

The compact dimensions :

- simplify transport and installation
- enable installation in the immediate vicinity of load
- greatly reduces installation costs (cost of ground, civil works erection) which play a large part in the price of an "open" substation.

#### Installation : indoor or outdoor

Hexabloc has been designed for outdoor unprotected installation. The reduced size allows the equipment to be installed in enclosed premises which can also be small, therefore less costly.

#### Elimination of harmful effects

Harmful effects caused by the corona and radio interferences are totally eliminated with GIS.

Moreover, the Hexabloc substation is silent. So there is no noise problem when installed in residential areas.

#### Ease of transport and installation

A Hexabloc H9S substation consists of factory assembled and tested bays transported as such to the site. Each

bay is placed on the civil works without any additional assembly other than connections between the various bays, and to incoming and outgoing feeders. Bursbars are fitted with connectors consisting of robust contact fingers. Civil works are kept to a minimum with two rails or concrete beams and power cable ducts.

#### Simplified maintenance and easy operation

Merlin Gerin's objective was :

- to simplify maintenance :
  - mechanical protection provided by the enclosures
  - chemical neutrality of SF6
  - electrical endurance of the circuit-breaker
- to provide sufficient room for the necessary operations, whilst gaining the benefit of a compact design
- standardization of sections requiring only a small number of spares to be kept in stock
- reduced weight due to light alloy construction, small dimensions, etc...

#### Bay cross section :

- 1 Busbars
- 2 Disconnecter
- 3 Grounding switch
- 4 Circuit breaker
- 5 Current transformer
- 6 Voltage transformer
- 7 Cable termination

Outdoor 245 kV GIS



Section of a bay (double busbars and cable termination)

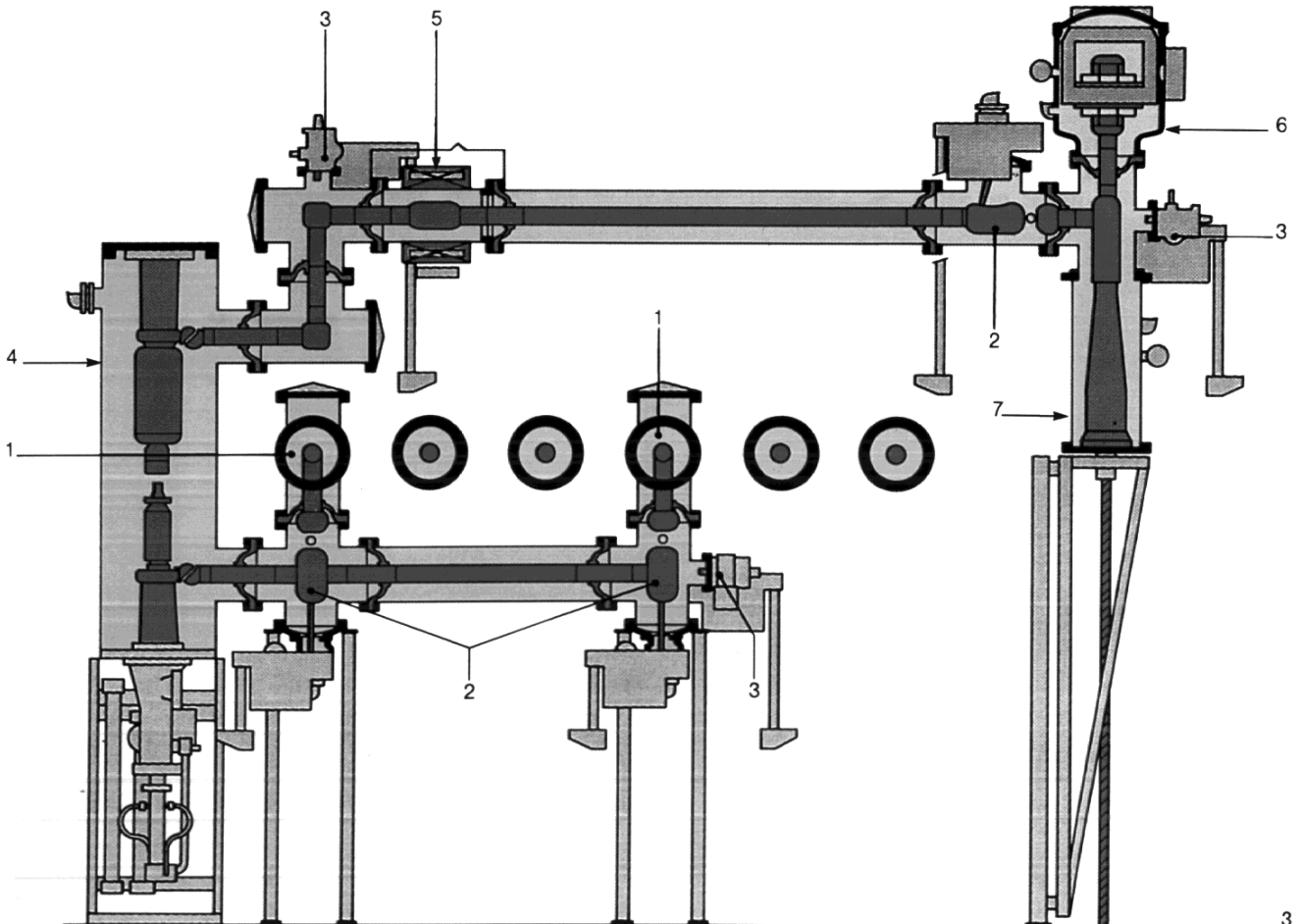

<b>summary</b>	page
<b>introduction</b>	2
<b>technical options</b>	4
<b>technology</b>	6
<b>quality</b>	8
<b>tests</b>	10
<b>Hexabloc H9S electrical characteristics and functions</b>	12
<b>transport, erection on site</b>	18
<b>installation</b>	18
<b>maintenance</b>	20

# technical options

The major technical options distinguishing Hexabloc H9S equipment are :

- Metalcladding (one enclosure per phase)
  - Insulation using SF6 gas
  - Internal compartments.
- 
- ensures a tight enclosure
  - protects the switchgear from external agents
  - forms an earthing circuit.

SF6 has been chosen because of its excellent dielectric and interrupting properties.

These ensure internal separation of functions. Each piece of equipment forms a separate sealed compartment .

Separate compartments simplify maintenance :

- finding leaks is easier
- replacing a given piece of equipment is simplified as it is an independent element which can be depressurized without affecting continuity of service of adjacent bays
- limiting the portion of work reduces the quantity of gas to be handled thus reducing down-time.

Other features of separate compartments are :

- pressure monitoring, fault location, fault limiting. If the pressure of SF6 gas accidentally drops to the atmospheric pressure, rated voltage withstand is still guaranteed.

However, overvoltage withstand and breaking capacity are directly linked to the pressure of the gas.

The pressure is therefore permanently monitored in each compartment by a temperature-compensated multilevel setting plug-in type pressure-switch. Moreover, each compartment is fitted with an overpressure limiting device. This is a disc (or «membrane») designed to function under pressure, like a safety valve.

**SF6 molecule**

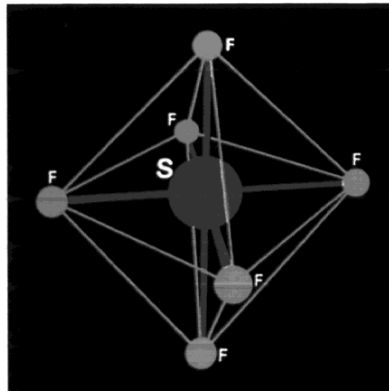

**Enclosure**

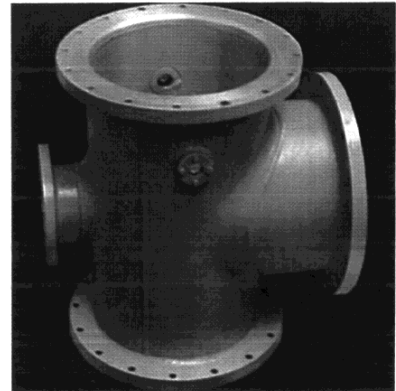

Hexabloc H9S computer aided design (HEXADES)

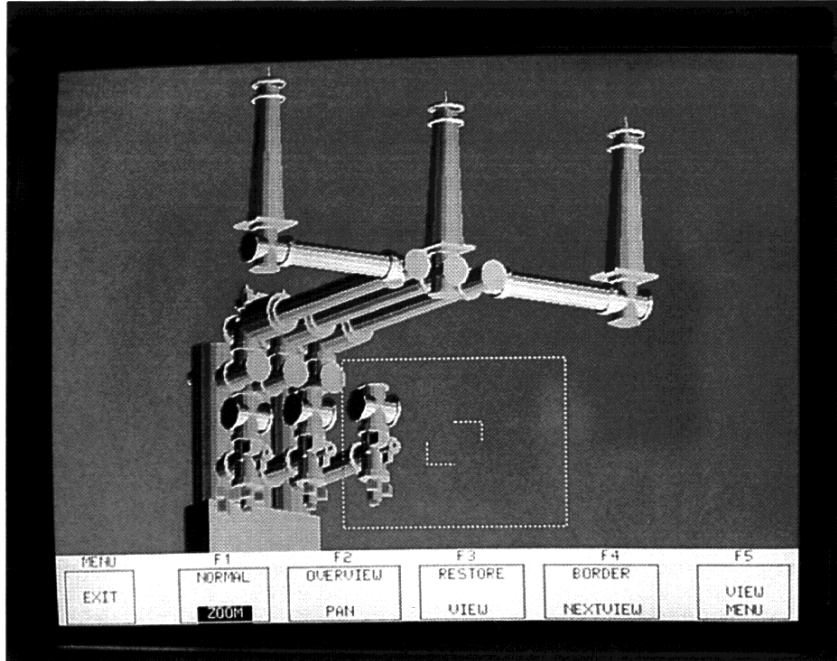

Internal partitioning

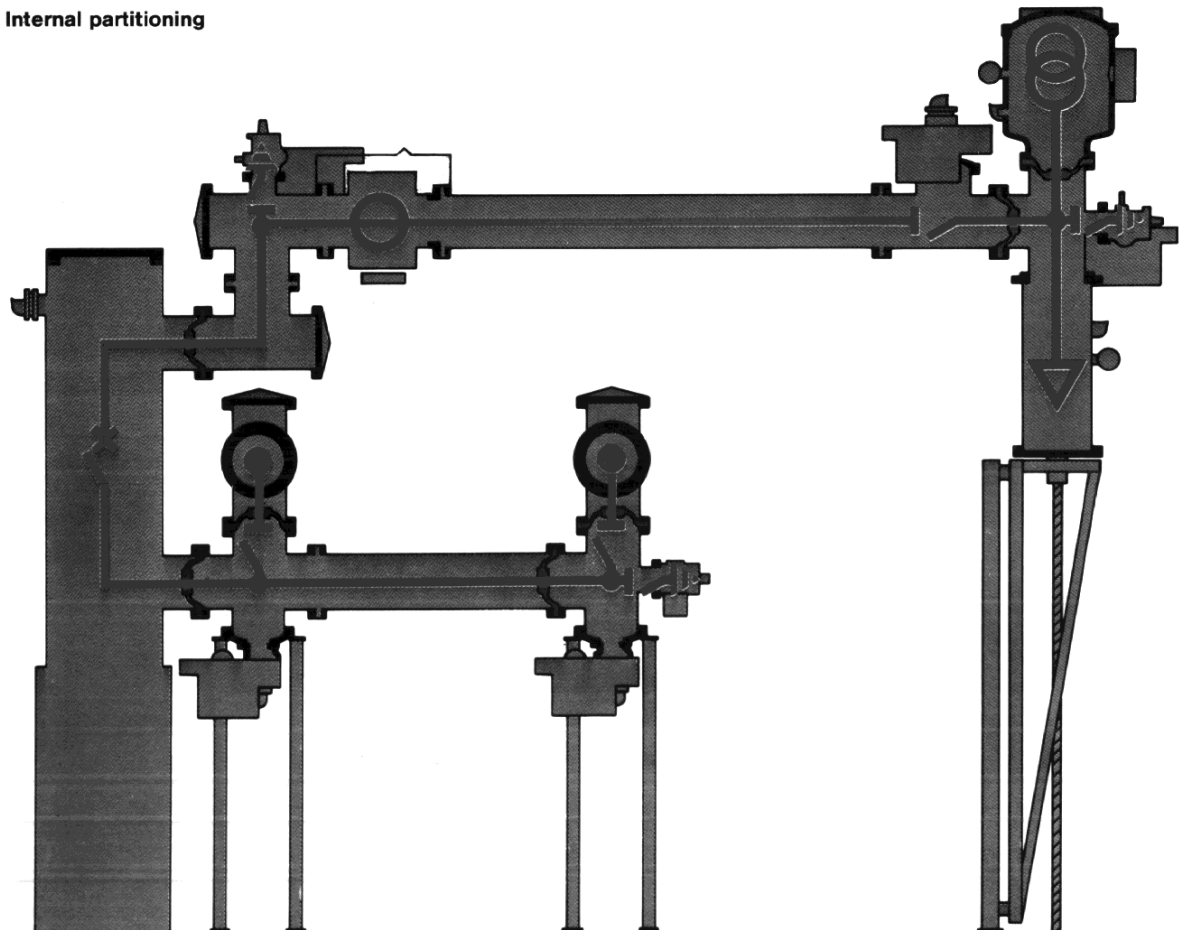

# technology

Hexabloc technology is based on many years' experience :

■ **the metal enclosure** is made from a light aluminium alloy. This has several advantages :

- reduction in weight - easy handling
- resistance to corrosion
- no eddy currents, thus reducing overheating.

■ **tightness**

The tightness of enclosures is obtained with well-tried manufacturing processes :

- units positioned with tools before welding
- automatic welding
- checking tightness of welds.

Tightness of sub-assemblies is achieved :

- between compartments, with insulators which also act as conductor supports.
- between compartments and outside, with o-rings : one or two concentric rings depending on their position and size.

■ **absorption of SF6 decomposed products.**

This is achieved by absorbants placed in compartments where an electrical arc would be produced (e.g. circuit-breaker compartment).

■ **particle trap**

All the compartments are provided with particle traps located on the gas barriers.

■ **choice of SF6 pressure**

SF6 pressure, monitored by the pressure-switches has been fixed at 3.5 bars (relative pressure) at 20°C for all the compartments except the breaker compartment which is at 5.5 bars.

SF6 pressure variation versus temperature

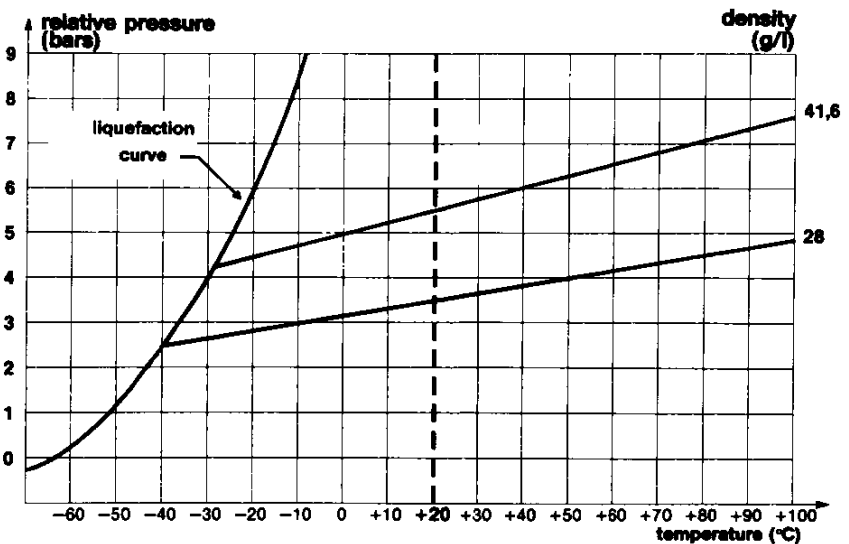

Machine for forming of tee-connections

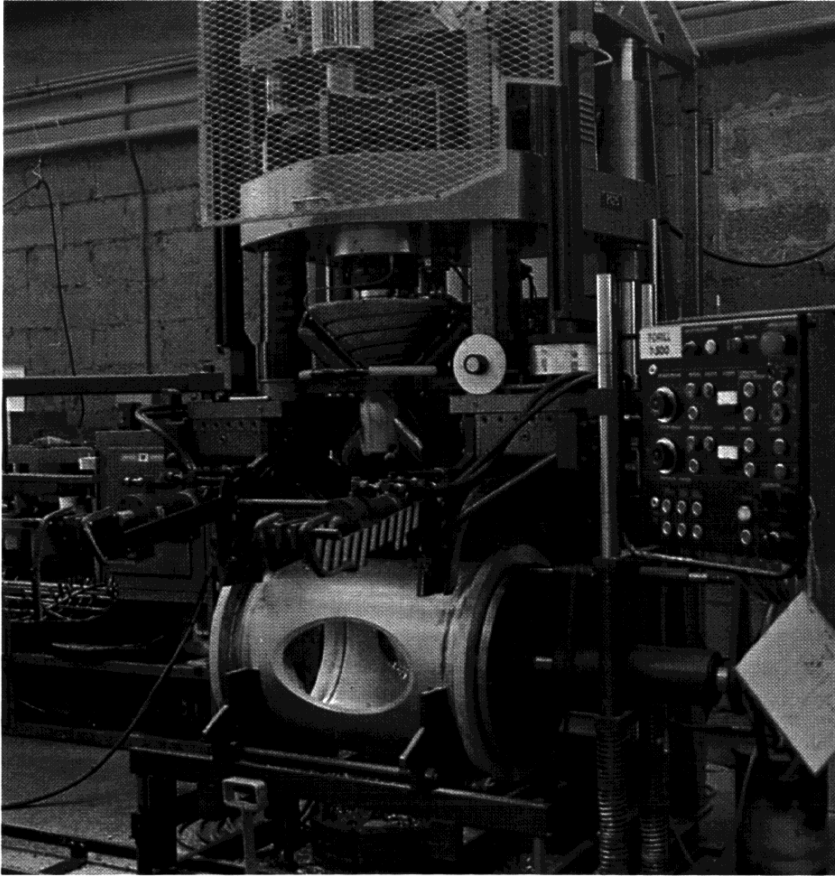

Tightness device

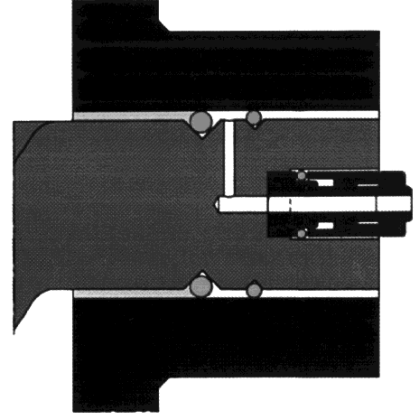

Diagram of a connecting flange with its two o-rings. The venting aperture is for the checking of the inner seal gastightness.

Automatic machining system with digital control



# quality

The products' ability to perform to the customer's satisfaction is Merlin Gerin's basic objective.

To achieve this objective, Merlin Gerin has a Quality Organization based on the concept of Quality Assurance, that is a network of planned, systematic means designed to ensure conformity of supplied products and services with the client's requirements. This system prevents, detects and corrects any possible malfunctioning, and also avoids its recurrence and ensures that the correcting actions are implemented:

- the quality assurance programme is in charge of the implementation of the Quality Assurance programme whose procedures for organization and internal operations are documented in the regularly updated Quality Assurance Manual. The internal audit ensures that the Q.A. programme is properly carried out.
- the Product Quality Assurance is responsible, broadly speaking, for the control of the product design and its application to various contracts, the supplier's audits and the schedules for inspection visits and test planning.
- the Quality Inspection is performed through out the manufacturing processes. It is a valuable «tool» for the Quality Assurance.
- the Incoming Quality Inspection ensures the quality control of the total external procurement.
- the in Process Quality Inspection ensures the control of intermediary operations of assembly, final electric and mechanical tests and checks conformity of products with the requirements specified in the contract.
- the Final (on site) Quality Inspection ensures the controls of the proper on-site assembly operations as well as the dielectric tests prior to commissioning. All results obtained during inspection visits and on-site tests are documented in a test report handed over to the customer.

To sum up, Merlin Gerin places great emphasis on the Quality Assurance and Quality Control and, for these reasons, stringent quality control measures are imposed along the manufacturing and assembly of the product.

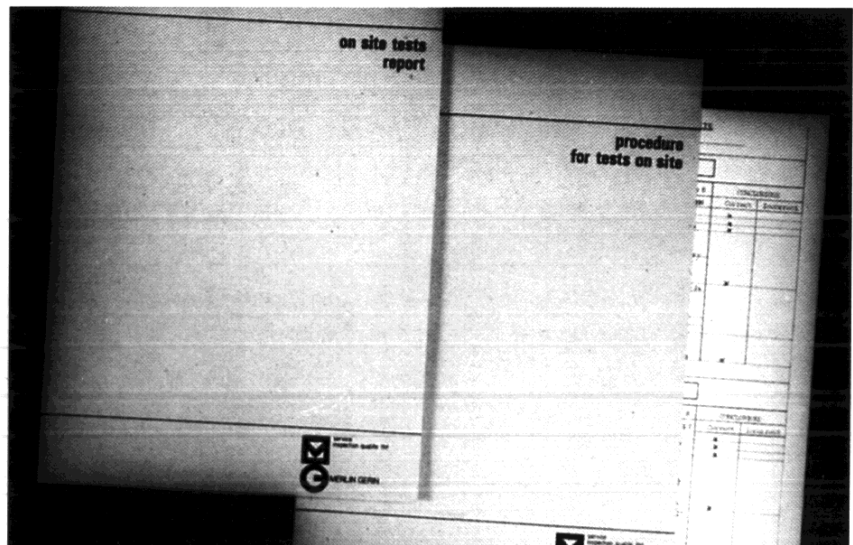

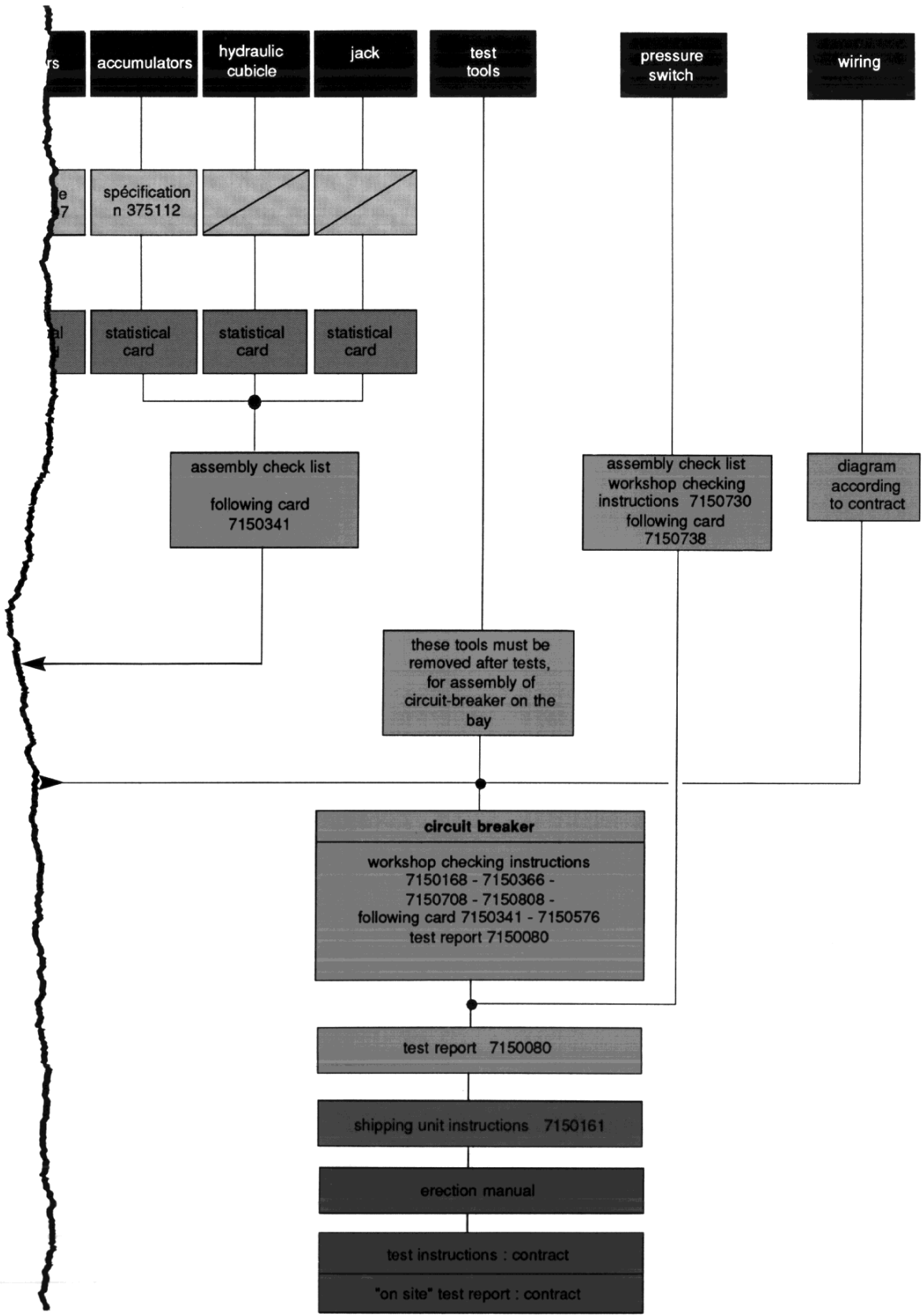

rs

accumulators

hydraulic cubicle

jack

test tools

pressure switch

wiring

le  
7

spécification n 375112

[diagonal line]

[diagonal line]

al

statistical card

statistical card

statistical card

assembly check list  
following card 7150341

assembly check list  
workshop checking instructions 7150730  
following card 7150738

diagram according to contract

these tools must be removed after tests, for assembly of circuit-breaker on the bay

**circuit breaker**  
workshop checking instructions 7150168 - 7150366 - 7150708 - 7150808 - following card 7150341 - 7150576  
test report 7150080

test report 7150080

shipping unit instructions 7150161

erection manual

test instructions : contract

"on site" test report : contract

Quality inspection : circuit breaker control "flow chart"

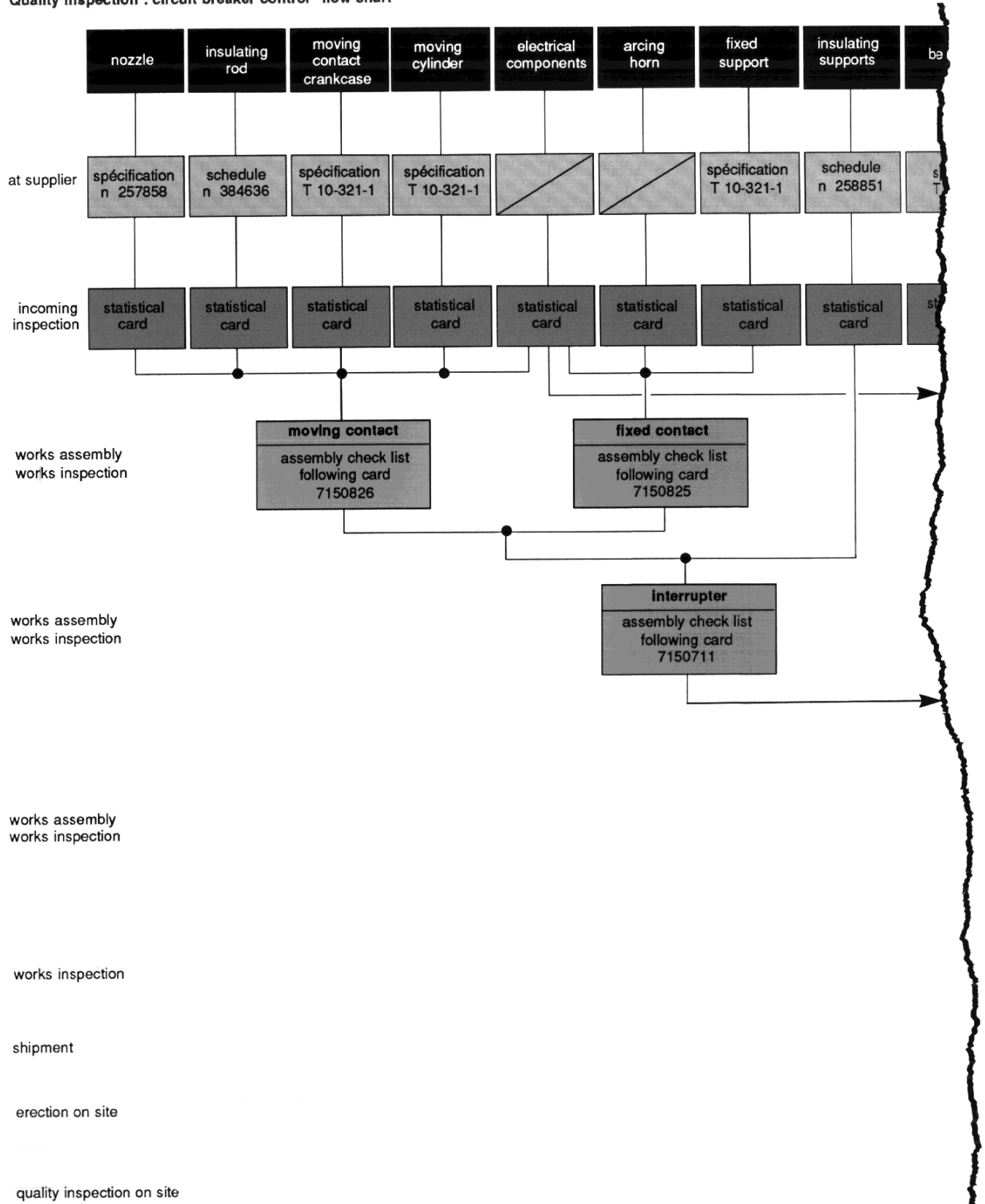

# tests

## Type tests

Hexabloc H9S has undergone type tests prescribed by international standards and the specifications :

- dielectric withstand
- temperature rise
- short circuit withstand
- breaking capacity tests (terminal and short line faults, etc..)
- internal faults
- measuring contact resistances and operating speeds
- mechanical and environmental tests
- long-time ageing tests.

## Routine tests

- in the works : tightness, dielectric including partial discharges, contact resistance and operation tests
- on site after erection : tightness of sub-assemblies, dielectric, contact resistance and operating tests.

**Dielectric routine tests using a gas insulated test unit**

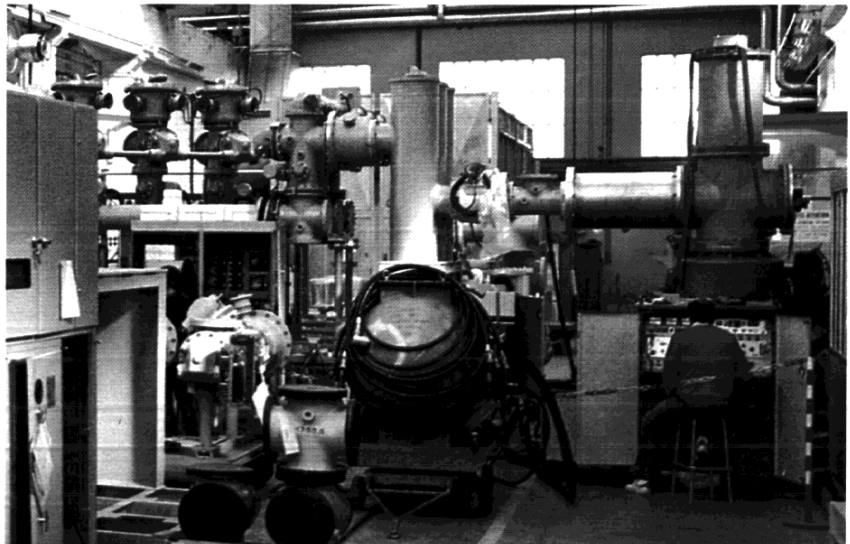

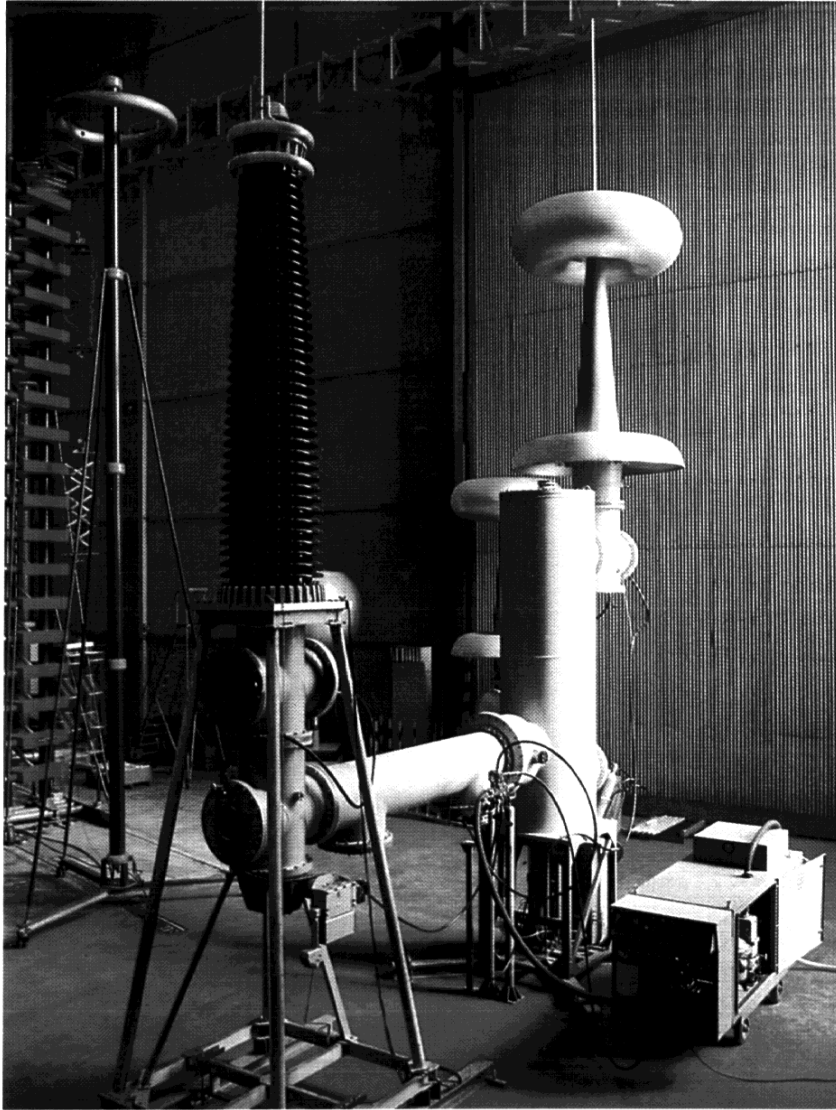

Dielectric tests on Hexabloc units



Dielectric tests on site, after erection

# Hexabloc H9S electrical characteristics and functions

## electrical characteristics

Rated voltage (kV)	245 and 300
Rated insulation level (kV peak)	1050
Rated current (A)	3150
Circuit-breaker breaking capacity from 50 to 60 Hz (kA)	40 and 50
Short time current withstand (kA/3 s)	40 and 50

## insulation

The switchgear is insulated by :

- the SF6 gas
- support insulators whose material (epoxy resin) and shape have been determined by computer studies and numerous tests in order to provide the switchgear with :
  - mechanical resistance to permanent and electrodynamic withstand
  - dielectric withstand (power frequency, lightning and switching impulse, low partial discharges, atmospheric pressure withstand)
  - thermal withstand
  - overpressure withstand.

## functions

### circuit-breaker

The circuit breaker used is an SF6 single pressure puffer type breaker. The «current flow» function and «breaking function» are separate and entrusted to different contacts of the same moving unit :

- «main contact» for current flow
- «arcing contact» for breaking.

### Circuit breaker cross section :

- 1 Enclosure
- 2 Interrupter
- 3 Gas barrier insulator
- 4 Connections
- 5 Hydraulic jack
- 6 Accumulator
- 7 Pressure-switch
- 8 Over pressure limiter

### Interrupter cross section (3 positions) :

- 1 Main fixed contact
- 2 Fixed arcing contact
- 3 Main moving contact
- 4 Moving arcing contact
- 5 Contact fingers
- 6 Compression cylinder
- 7 Insulating rod
- 8 Nozzle

### Operating mechanism

Hydraulic, oil pressure, with :

- motor-pump unit
- emergency hand pump
- electro-valves
- hydraulic jack.

### Hydraulic schematic diagram :

- 1 Oil tank
- 2 Jack
- 3 Pressure accumulator
- 4 Main valve
- 5 Close and trip coils
- 6 LP auxiliary tank
- 7 Motor pump
- 8 Hand pump
- 9 Auxiliary contact control device
- 10 Oil pressure switch
- 11 Connection for calibrated gauge
- 12 Safety valve

Circuit breaker-Section

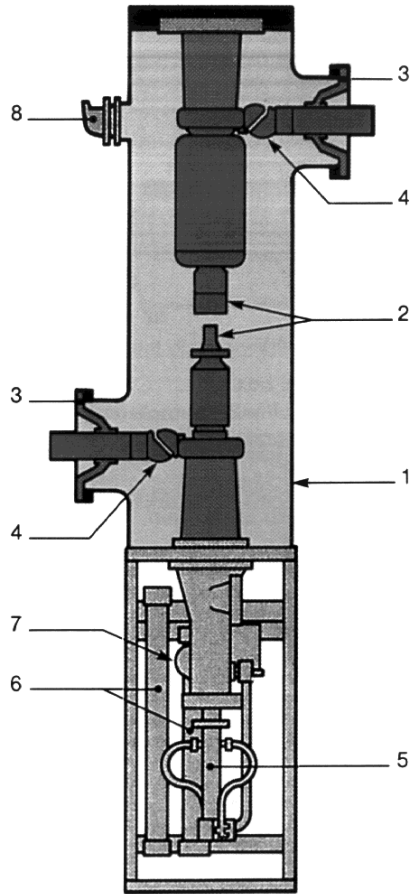

Circuit breaker interrupter

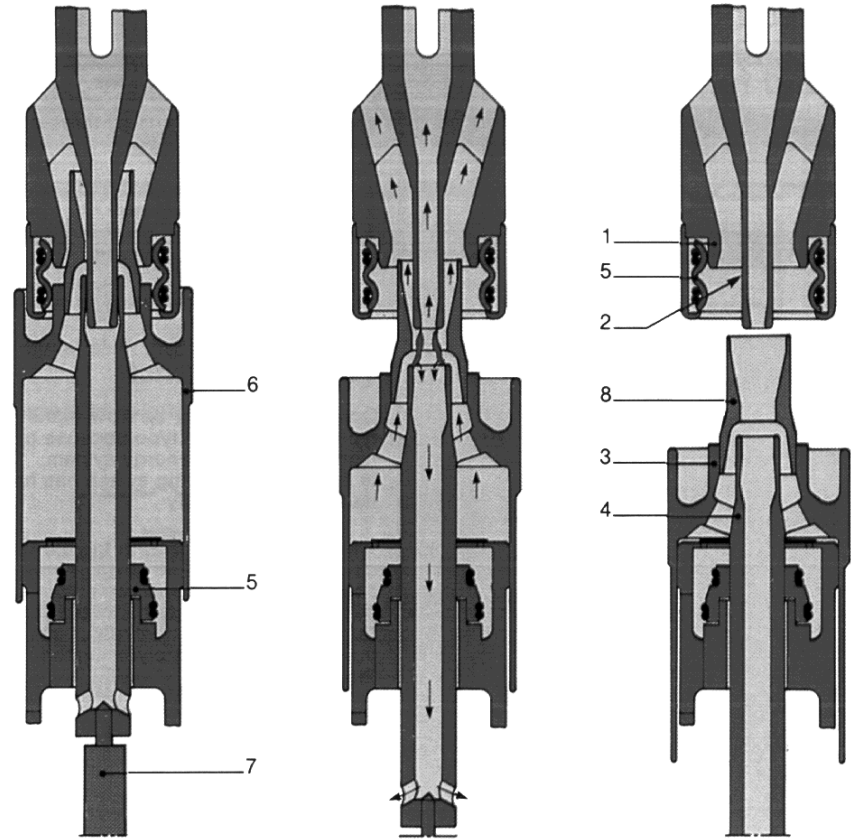

in «closed» position

during tripping operation

in «open» position

Circuit breaker hydraulic operating mechanism - Schematic diagram

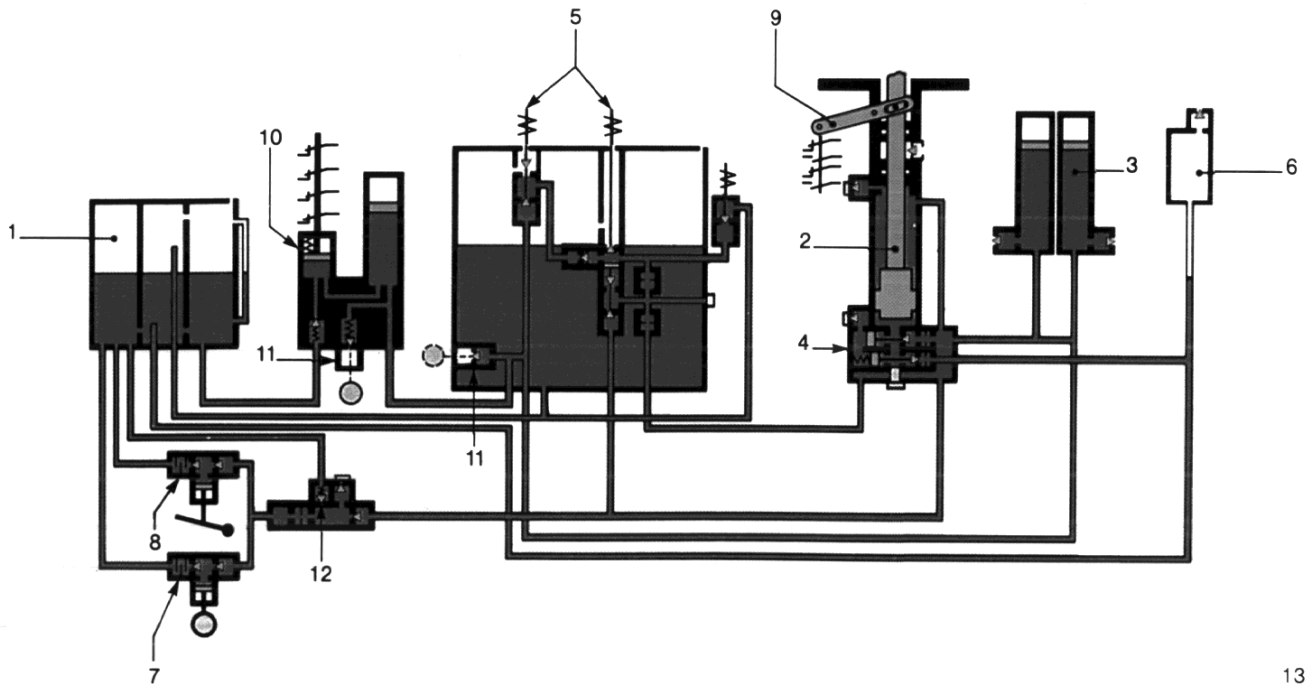

## Hexabloc H9S electrical characteristics and functions

### disconnecter

Depending on the layout, there is a choice between two disconnectors

- axial movement disconnector
- angular shaft disconnector.

Position signalling is at the end of the control shaft common to all three poles.

#### Cross section :

- 1 Operating mechanism
- 2 Insulating rod (or shaft)
- 3 Moving contact
- 4 Fixed contact
- 5 Pressure switch
- 6 Overpressure limiter
- 7 Viewing window

### grounding switch

Operation can either be slow-make type or quick-make type because of the high speed stored energy system. In this case grounding switch has full fault making capacity .

The contacts are linked to the earthing circuit via bushings fitted on the crank-case. For special measurements, namely current injection, contact resistance measurement, etc..., each outlet can be separately insulated from the earthing circuit.

#### Cross section :

- 1 Operating mechanism
- 2 Moving contact
- 3 Fixed contact
- 4 Bushing terminal
- 5 Position indicator

### grounding switch and disconnecter operating mechanism

This is common to the three poles. It can be :

- manual-lever
- electric ("Vegalec" type) reduction gear motor and worm screw type. The nut on the worm screw drives a handle on the axle of the mechanism. The operating mechanism accepts different types of interlocks.

#### Electrical operating mechanism

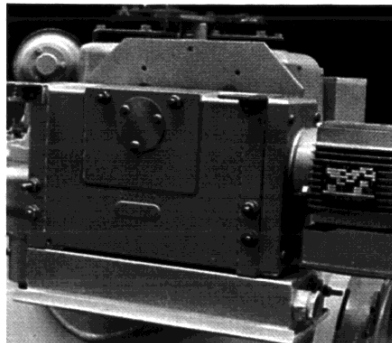

### voltage transformer

#### Cross section :

- 1 Enclosure
- 2 Magnetic circuit
- 3 Primary
- 4 Secondary
- 5 Terminal box
- 6 Pressure switch
- 7 Overpressure limiter

### current transformer

#### Cross section :

- 1 Enclosure
- 2 Magnetic circuit
- 3 Primary
- 4 Secondary
- 5 Shunt
- 6 Terminal box

### surge arrester

Various types of surge arresters can be installed in SF6 enclosures (especially gapless zinc oxide type).

### busbars

Hexabloc H9S has separate phases (one enclosure per phase). However it is possible to reduce the dimensions by equipping the busbars with one enclosure for the three phases.

#### Section of a busbar element or bus trunking with one enclosure per phase :

- 1 Enclosure
- 2 Connection flange
- 3 Insulator
- 4 Conductor

#### Section of a busbar element with enclosure common to all 3 phases :

- 1 Enclosure
- 2 Connection flange
- 3 Insulating spacer
- 4 Insulators
- 5 Conductor bars

**Disconnecter - Section**

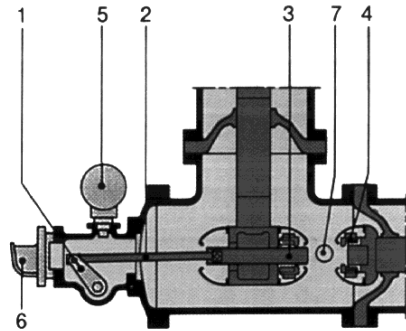

Axial movement disconnector

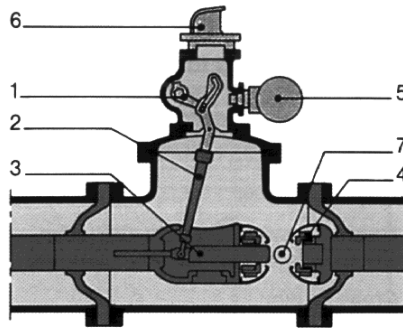

Angular shaft disconnector

**Grounding switch - Section**

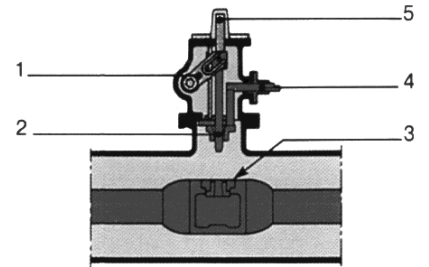

**Voltage transformer - Section**

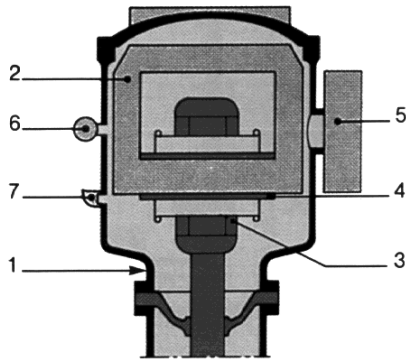

**Current transformer - Section**

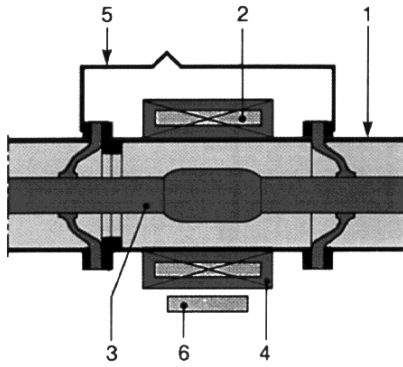

**Busbar with one enclosure per phase - Section**

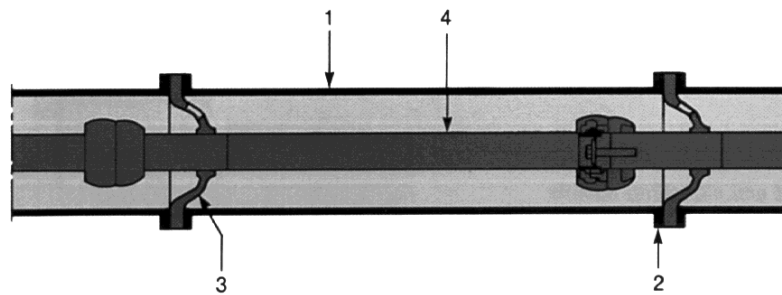

**Busbar with enclosure common to all 3 phases - Section**

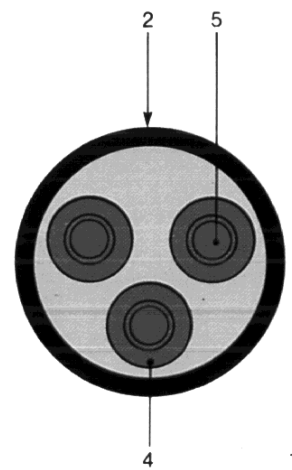
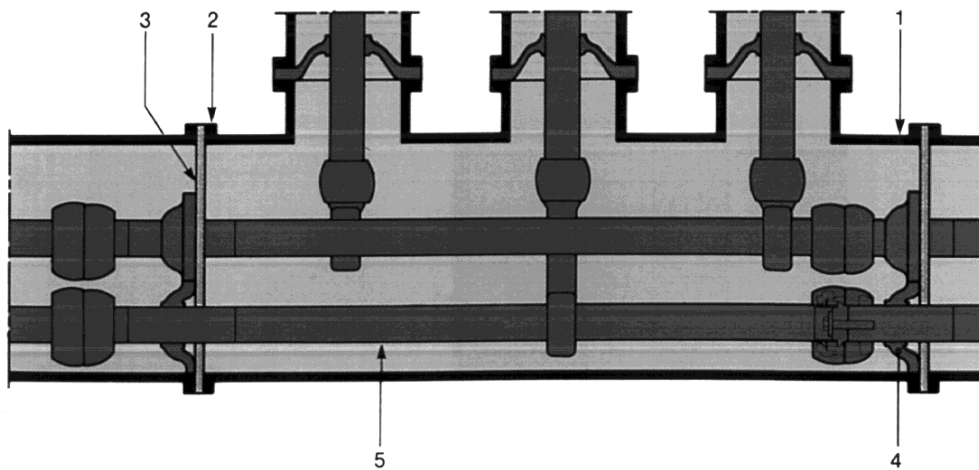

## Hexabloc H9S electrical characteristics and functions

### interfaces

All modes of connection are possible.

#### Air/SF6 bushing for overhead line connection

**Cross section :**

- 1 Enclosure
- 2 Insulator
- 3 Conductor

#### Cable termination with GIS (dry insulated or impregnated cables)

**Cross section :**

- 1 Enclosure
- 2 Insulator
- 3 Cable
- 4 Connector
- 5 Connection to cable testing device

#### Connection to power transformer

**Cross section :**

- 1 Enclosure
- 2 Transformer terminal
- 3 Connector
- 4 Expansion bellow

### local control cubicle

A cubicle near the bay groups together all the equipment necessary for control and monitoring :

- control equipment : push button, signalling lamps, relays,...
- protection of GIS : pressure-switch indication feedback, signalling and alarm sequences, electrical interlocks, instrument transformer secondary connection.

### Control and signalling cubicle

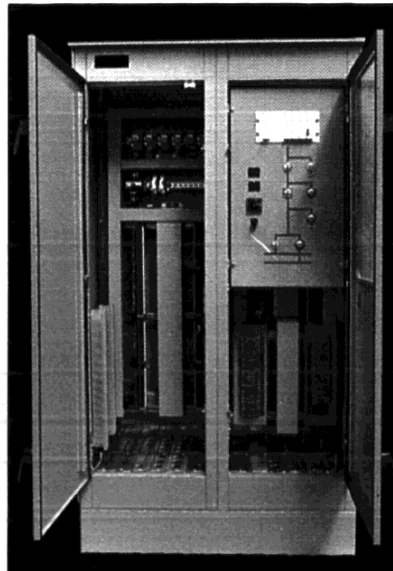

**Air/SF6 bushing for overhead line connection - Section**

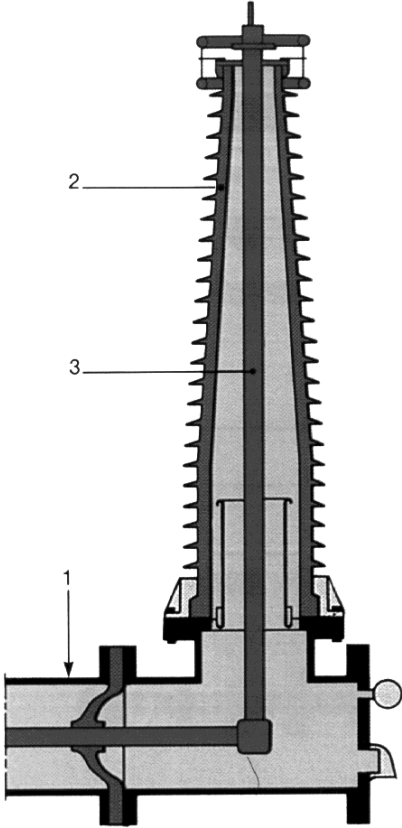

**Connection to power transformer - Section**

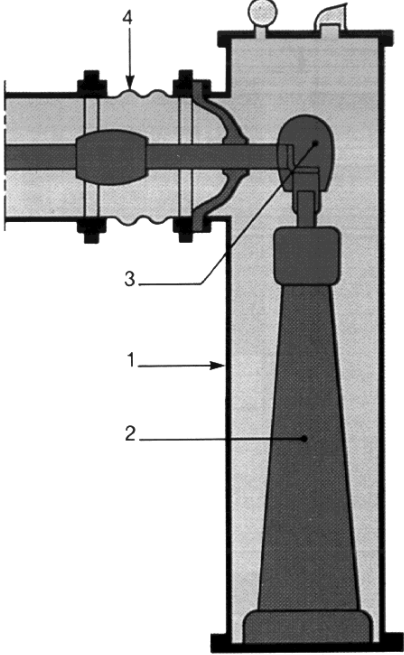

**Cable termination - Section**

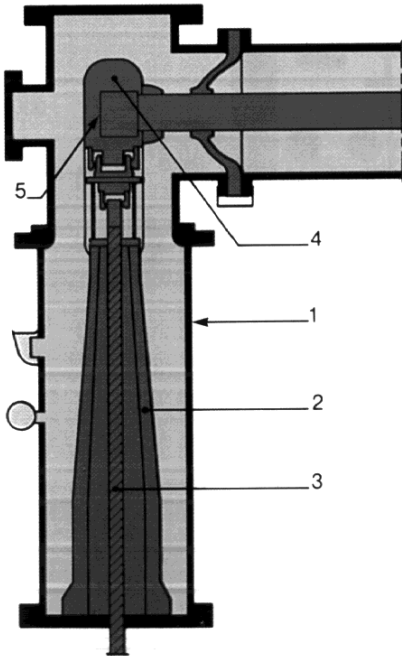

# installation

All schemes are possible; the most common are shown below as examples :  
«Double busbar» bay - (busbar with enclosure common to all 3 phases)

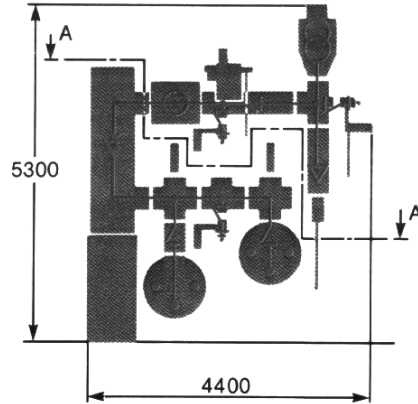

view AA

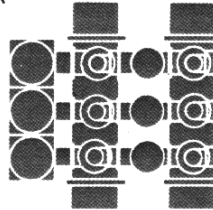

«Busbar coupling» bay

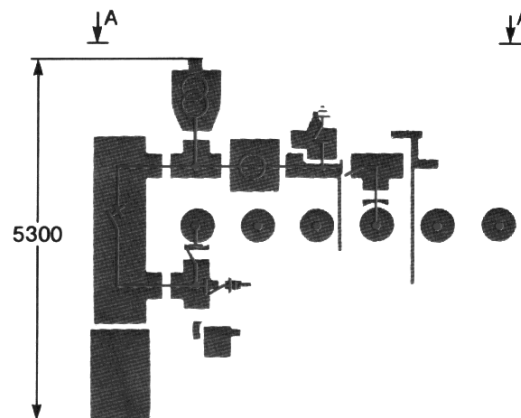

view AA

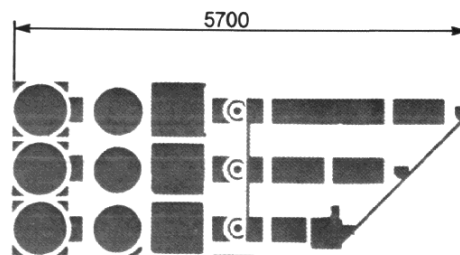

«Double busbar» bay - (busbar with one enclosure per phase)

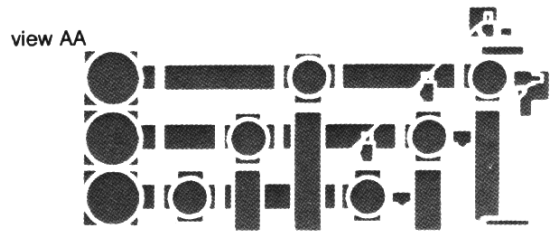
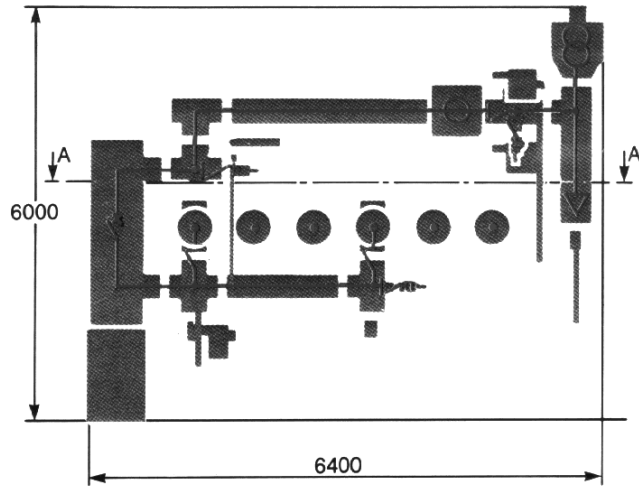

«Breaker and a half» bay

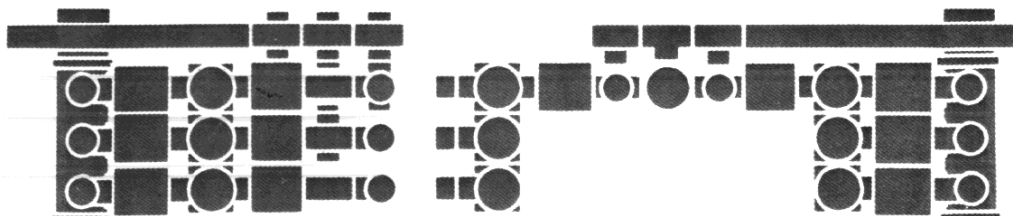
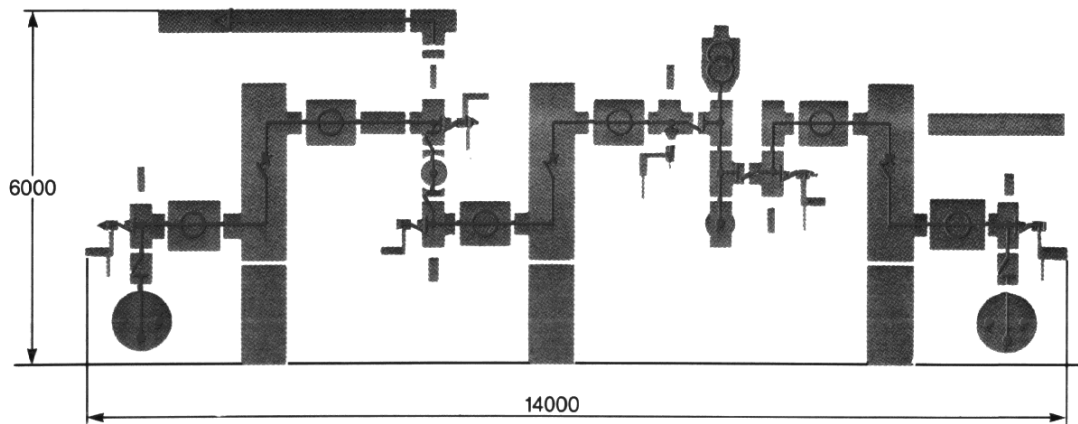

## transport erection on site

A Hexabloc H9S bay is brought to the site fully assembled and wired. Erection work on site is therefore simple :

- positioning of pre-assembled unit on civil works
- connections :
  - power circuit
  - auxiliary circuit
  - earthing circuit.

Civil works : in the most frequent case (outdoor installation) civil work is very simple : two concrete beams and troughs for cables (if necessary).

Tests on site : the equipment is fully and systematically tested in the works, thus tests on site are limited to pre-commissioning tests.

Precise quality control check lists and manuals ensure that all the equipment supplied has been correctly tested.

## maintenance

One of the main advantages of Merlin Gerin's gas insulated switchgear is that it is practically maintenance free :

- The active parts, protected by encapsulation and the neutral SF6 gas require no maintenance during the whole life of the installation.
- Cleaning the insulators, a considerable constraint in open type substations, is practically eliminated.
- Very high electrical endurance of circuit-breaker contacts means that in most cases they will never be replaced.

Maintenance is thus virtually limited to monitoring :

- gas pressure and topping up if the pressure drops
- oil level in hydraulic operating mechanism of circuit-breaker and replacement of oil at regular intervals.

### Hexabloc bays loaded on truck for dispatch

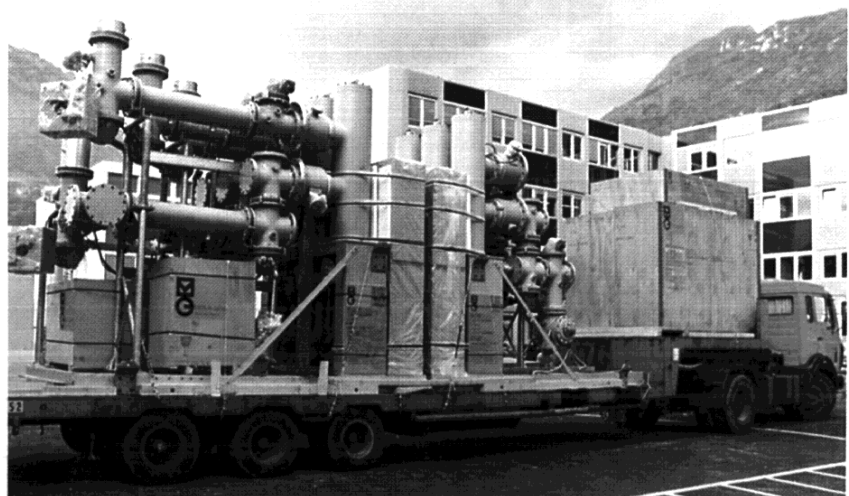

Square D Company  
1700 Sunshine Drive  
Clearwater, FL 34625

0150CT9404 AC0148/1E