



SQUARE D
Instruction Bulletin

Bulletin 6055-30
August 1995
Smyrna, TN, USA

MASTERCLAD™ Metal-Clad Indoor Switchgear

4.76–15.0 kV

Series 5

With Type VR Vacuum Circuit Breakers

Class 6055

PRELIMINARY

NOTICE

Read these instructions carefully and look at the equipment to become familiar with the device before trying to install, operate, or maintain it. The following special messages may appear throughout this manual to warn of potential hazards and to call attention to additional information which clarifies or simplifies a procedure.

DANGER

Used where there is a hazard of severe bodily injury or death. Failure to follow a "DANGER" instruction *will* result in *severe* bodily injury or death.

WARNING

Used where there is a hazard of severe bodily injury or death. Failure to follow a "WARNING" instruction can result in severe bodily injury or death.

CAUTION

Used where there is a hazard of minor bodily injury or equipment damage. Failure to follow a "CAUTION" instruction can result in minor bodily injury or equipment damage .

PRELIMINARY

Square D and  are Registered Trademarks of Square D Company

MASTERCLAD is a Trademark of Square D Company.

© 1995 Square D Company. All rights reserved. This bulletin may not be copied in whole or in part, or transferred to any other media, without the written permission of Square D Company.

PRELIMINARY

CONTENTS

1. INTRODUCTION	1
2. SAFETY PRECAUTIONS	3
3. RECEIVING, HANDLING, AND STORAGE	4
Receiving	4
Handling	4
Storage	4
4. DESCRIPTION	6
Front Section	7
Circuit Breaker Cell	7
Circuit Breaker Positioning Rails	8
Racking Mechanism	9
Circuit Breaker Position Indicator	9
Disconnect Position Latch	9
Circuit Breaker Interlocks	9
Compartment Rating Interlock	10
Control Power Receptacle	10
Ground And Test Unit Dummy Circuit Breaker Interlock	10
Primary High Voltage Contacts	10
Current Transformers	11
Shutters	11
Barrier	11
Cell Interlock	12
Ground Contact Bar	12
Mechanism Operated Contacts (MOC)—Optional	12
Truck Operated Contacts (TOC)—Optional	13
VT, CPT, And Fuse Drawout Units	13
Drawout Voltage Transformer Compartment	14
Drawout Control Power Transformer Compartment	14
Drawout Fuse Compartment	16
Main Bus Compartment	16
Cable Compartments	16
Surge Arresters	17
5. OPERATING INSTRUCTIONS	18
Circuit Breaker-Circuit Breaker Cell Interlock System	18
Circuit Breaker Operation	18
Racking Mechanism	18
Control Power Plug	19
Disconnect Position Latch	19
Manual Spring Charging Mechanism	19
Manual Close And Open Pushbuttons	19
6. INSTALLATION	20
Site Preparation	20
Foundation	20
Switchgear Installation	21
High-Potential Testing	26
Phasing	26
Cable Connections	26
7. START-UP	28

PRELIMINARY

Bulletin 6055-30
August 1995

CONTENTS (cont.)

8. INSPECTION AND MAINTENANCE	29
Main Bus Compartment	26
Cable Compartment	29
Circuit Breaker Compartment	29
Circuit Breakers	30
VT, CPT and Fuse Drawout Units	30
9. ACCESSORIES	32
Circuit Breaker Lift Truck	32
Test Cabinet—Optional	32
Ground And Test Device—Optional	32
10. OUTLINE	34
11. INSTALLATION AND MAINTENANCE LOG	35

ILLUSTRATIONS

Figure	Page
1. Circuit breaker cell, VT and CPT drawouts	2
2. Circuit breaker in lower circuit bkr cell; Upper circuit bkr w/o circuit bkr or barrier	6
3. Switchgear, upper and lower circuit breaker cell	7
4. Circuit breaker floor plate/racking device and interlock	8
5. Vacuum circuit breaker Type VR (front view)	10
6. Vacuum circuit breaker Type VR (rear view)	11
7. Circuit breaker cell—shutter forced open	12
8. Circuit breaker cell with barrier	13
9. VT drawout	14
10. Control power transformer —secondary circuit breaker interlock	14
11. Drawout units in withdrawn position	15
12. Drawout units in connected (operating) position	15
13. Two-bay structure—rear view	17
14. Switchgear mounting floor channels	20
15. Floor plan	21
16. Main bus assembly	23
17. Main bus connections—side view	23
18. Main bus connections—top view	23
19. Main bus pass-through, porcelain—optional	24
20. Stand-off bus support	24
21. High voltage cable lug insulation	27
22. Wall-mounted test cabinet—optional	33
23. MASTERCLAD indoor switchgear outline	37

TABLES

1. Bolt Torque	25
2. One Minute High-Potential Test	26

SECTION 1—INTRODUCTION

Square D two-high 4.76–15.0 kV drawout MASTERCLAD metal-clad switchgear (figure 1, page 2) is designed to provide a reliable source for medium voltage power distribution. The drawout circuit breaker type VR employs state-of-the-art vacuum technology.

The assembly consists of individually-grounded, compartmentalized steel structures. Each compartment has doors, barriers, and removable access panels to isolate the separate working functions and to provide personnel protection. All of the circuit breakers, instrument and control power transformers, relays, meters, and other components are factory-assembled, wired, and tested as an assembly. The user normally makes only the external control, ground, and power connections at the terminals provided, and reconnects the wiring and busbars at the shipping breaks.

Each assembly is custom-designed to the user's specifications. Standard structures and bus configurations are arranged per customer specifications. The structures are then combined with the circuit breaker and other components necessary to provide the required protective scheme, metering, and number of feeders.

Complete customer drawings are furnished for each assembly. The drawings include floor plans and elevations, one-line diagrams, control schematics, and wiring diagrams.

PRELIMINARY

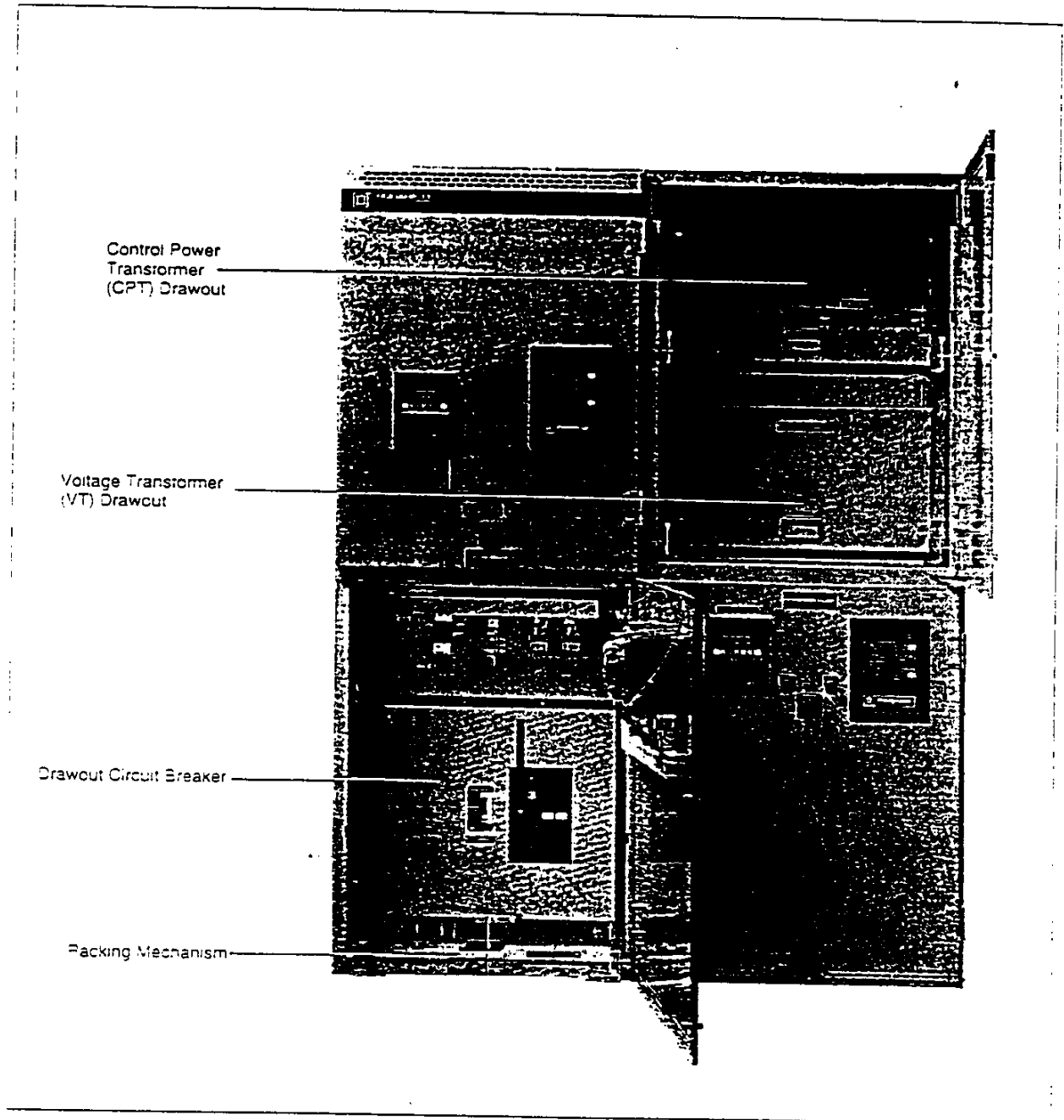

Figure 1: Circuit breaker cell, VT and CPT drawouts

SECTION 2—SAFETY PRECAUTIONS

DANGER

HAZARD OF BODILY INJURY OR EQUIPMENT DAMAGE.

- All personnel involved in handling, site preparation, installation, testing, operation, and maintenance should be thoroughly familiar with the information in this instruction bulletin and customer drawings provided *before* working on this equipment.
- The metal-clad switchgear protective features include automatic shutters, circuit breaker interlocks, and compartment barriers. All are designed to provide personnel protection when operated as instructed. Never make these interlocks inoperative or operate the equipment with any safety barriers removed.
- Always assume that all high-voltage parts are energized until it is certain they are de-energized.
- Use only test equipment rated for the service intended; incorrect use of such equipment can result in an explosion and serious personal injury.
- Check interconnection diagrams and make sure there are no backfeed potential sources.
- Never disconnect the main trip source of energized equipment.
- Do not open a circuit breaker door unless the circuit breaker is tripped.
- Move circuit breakers to the *disconnected* position before removing rear access panels.
- Use out-of-service tags and padlocks when working on equipment. Leave tags in place until the work is completed and the equipment is ready to be put back into service.
- When in doubt, stop and re-read the instruction manual or refer to the customer drawings before proceeding.
- The complete assembly arrangement determines if the top or bottom contacts are the line side; both can be energized when the circuit breaker is removed from the compartment (figure 1).
- Disconnect all high voltage to the switchgear before accessing the horizontal bus compartment.
- Do not use liquid fire extinguishers or water on electrical fires! Before extinguishing fires within the assembly, be absolutely certain the main power source is disconnected and the main and all feeder circuit breakers are tripped.
- This instruction bulletin does not cover all possible equipment combinations nor does it cover circumstances that may arise during handling, installation, testing, operation, or maintenance. For additional information, contact the local Square D field office.

Failure to observe these precautions will result in severe personal injury, death, or equipment damage!

PRELIMINARY

SECTION 3—RECEIVING, HANDLING, STORAGE

Receiving

MASTERCLAD Two-high 4.76–15.0 kV metal-clad indoor switchgear is shipped on skids in protective crates or wrapping to prevent damage during normal transit. Circuit breakers are individually skid-mounted.

Inspect each crate for external damage or indications of rough handling before accepting the shipment. If there is any indication of external damage or mistreatment, or if the correct number of crates has not been received, make note of the situation on the shipping papers before signing them. Immediately file a formal damage claim with the carrier. Notify the local Square D field office about the extent of damage or shortages, and attach a copy of the formal damage claim.

Open the shipping crates as soon as possible after receipt and inspect the contents for damage. Check the packing list in detail against the equipment received to ensure the order and shipment are complete.

If the equipment is stored prior to installation, leave it on the shipping skids to facilitate moving it later.

Handling

The switchgear sections are normally shipped in one or two bays. Each section has four lifting lugs bolted on top. If more than two bays are shipped as one section, lifting channels or frames may be bolted on top. Put a crane hook through each of the four holes to lift and move the sections. After the group has been placed in position, remove and discard the lifting lugs, then screw the bolts back into place to cover the mounting holes.

If no crane is available, the sections may be unloaded and moved with a forklift. Rollers under the skids may be used on a relatively flat surface if other moving equipment is not available or space prohibits the use of other moving methods.

See Section 6, "Installation," for handling uncrated assemblies.



CAUTION

HAZARD OF EQUIPMENT DAMAGE.

Do not remove the skids until the shipping sections are in the final location. Do not maneuver the switchgear directly on rollers; always use the skids to prevent switchgear distortion or damage.

Failure to observe these precautions can result in equipment damage.

Storage

If the assembly is stored prior to installation, place it in a clean, dry, well-ventilated area with a mean temperature of approximately 70°F. Prohibit unauthorized personnel from entering the storage area to eliminate tampering. Place dust covers over circuit breakers. If space heaters are furnished in the assembly, energize them from an external source. Consult the schematic diagrams and wiring diagrams for a logical connection point, and for voltage and power requirements.

PRELIMINARY

Bulletin 6055-30
August 1995

If no space heaters are installed in the assembly, and the area is cold and damp, use a temporary heating source within the assembly. A minimum of 200 watts of heat per cell is recommended. Avoid greasy, smoky heaters; high carbon content smoke can deposit carbon on insulation, causing tracking and eventual insulation breakdowns.

DANGER

HAZARD OF PERSONAL INJURY.

If the space heaters are normally energized from the assembly control power transformer, open the control power transformer secondary circuit breaker, remove the primary current limiting fuses, and install an out-of-service tag before energizing the space heaters. This prevents backfeed to the main bus through the control power transformer.

Failure to observe this precaution can result in severe personal injury or death.

PRELIMINARY

SECTION 4—DESCRIPTION

A MASTERCLAD metal-clad switchgear assembly has a number of bays, depending on customer needs. Each bay is a separate rigid, self-contained, bolted structure fabricated of heavy gauge steel. It consists of:

- front section, secondary control
- circuit breaker cell, VT, CPT, and fuse drawout section
- main bus compartment
- cable compartment

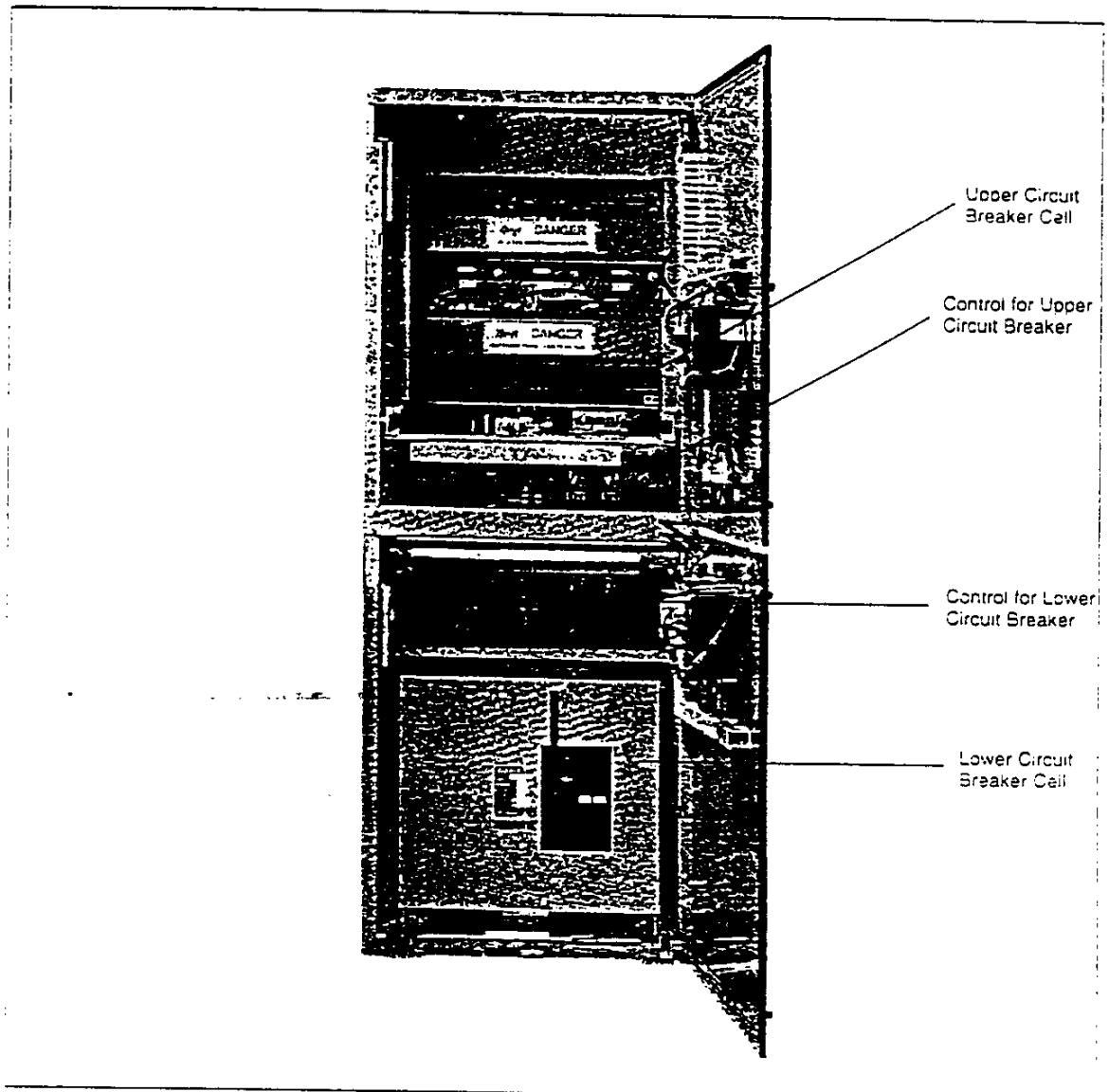

Figure 2: Circuit breaker in lower circuit breaker cell;
Upper circuit breaker cell without circuit breaker or barrier

Front Section

The front section includes the front hinged doors with instruments, relays, and control switches, the terminal blocks, fuse blocks, and other required secondary control devices. It also houses the wiring space for inter-unit connection and customer cable connections.

Circuit Breaker Cell

The circuit breaker cell contains 16 separate but coordinated features, each necessary for the safe operation of the circuit breaker:

- Circuit breaker positioning rails
- Racking mechanism
- Breaker position indicator
- Disconnect position latch
- Circuit breaker interlocks
- Compartment rating interlocks
- Secondary control power receptacle
- Ground and test unit interlock
- Primary high voltage contacts
- Current transformers
- Shutters
- Barrier
- Cell interlock
- Ground contact bar
- Mechanism operated contacts (MOC)—optional
- Truck operated contacts (TOC)—optional

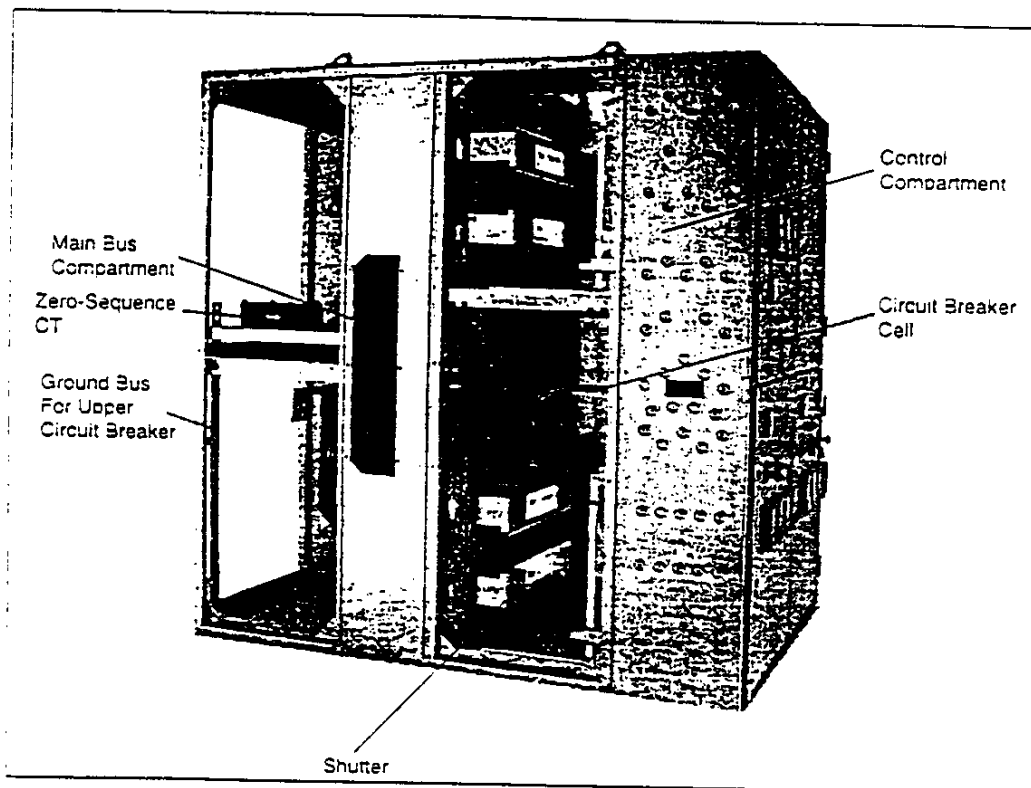
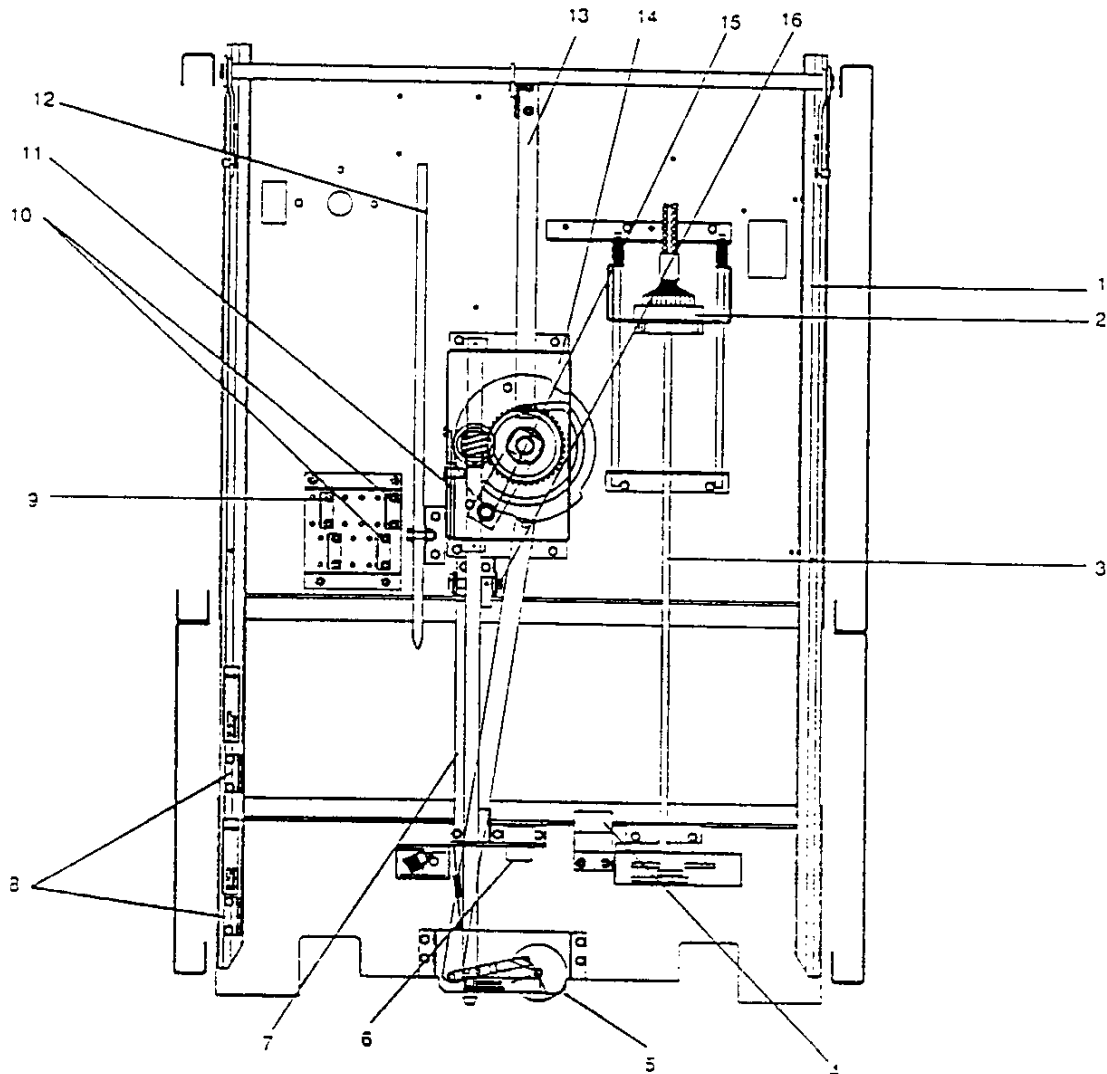

Figure 3: Switchgear, upper and lower circuit breaker cell

PRELIMINARY

Circuit Breaker Positioning Rails—The circuit breaker is equipped with one set of wheels for moving on the floor outside the switchgear, and a set of rollers which guide and position the circuit breaker inside the circuit breaker cell. All four rollers are captured in rails (figure 4) which position the circuit breaker in the vertical position.



- | | |
|---------------------------------------|--|
| 1. Circuit breaker rails | 9. Rating interlock |
| 2. Control power receptacle | 10. Ground and test unit dummy breaker interlock |
| 3. Control plug pull rod | 11. Racking block lever |
| 4. Spring discharge bracket | 12. Ground bus |
| 5. Circuit breaker position indicator | 13. Shutter actuator |
| 6. Cell key interlock | 14. Racking mechanism |
| 7. Racking block bar | 15. Racking roller |
| 8. Circuit breaker position latch | 16. Lockout lever |

Figure 4: Circuit breaker floor plate/racking device and interlock

Racking Mechanism—The racking mechanism is located on the circuit breaker cell floor. It is operated by a removable racking crank inserted into the front of the circuit breaker cell, with the front door either open or closed. The circuit breaker engages in a gear driven racking roller. As the roller rotates, it moves the breaker from the *test* to the *operating* position (figure 4).

Circuit Breaker Position Indicator—A rotating indicator beside the racking port indicates if the circuit breaker is in *test/disconnected*, *transit*, or *connected* position. When the door is open, two arrows that line up with the front cover are visible on the left hand rail. They also indicate the position of the circuit breaker.

Disconnect Position Latch—A spring loaded latch on the circuit breaker engages behind the latch brackets on top of the left hand guide rail when the circuit breaker is in the *test/disconnected* position. The latch is disengaged by the circuit breaker release handle (figure 5, page 10) in the *test/disconnected* position.

Circuit Breaker Interlocks

- A racking block bar welded to the racking shaft will hit an interlock pin on the circuit breaker when it is closed. This interlock mechanism will stop a closed circuit breaker from being moved between the *test/disconnected* position and the *connected* position. See figure 4.
- The racking roller actuates an interlock located underneath the circuit breaker. This interlock mechanism is designed to stop a circuit breaker from being closed when it is between the *test/disconnected* position and the *connected* position.
- A "lockout lever" located on the drawout gear box stops the circuit breaker from being inserted into the cell when the racking roller is not in the *test* position. See figure 4.
- A "racking block lever" will not allow racking mechanism operation when the circuit breaker is not in the cell. Without the circuit breaker in the cell, the shutter cannot be opened. This interlock provision can be defeated by simultaneously holding the lever down and turning the racking crank. Refer to figure 4.
- A "spring discharge interlock" will discharge the closing and tripping springs when the circuit breaker is inserted or withdrawn from the cell (figure 4).



CAUTION

HAZARD OF EQUIPMENT DAMAGE.

Do not test interlocks by hand. Test interlocks only by moving the circuit breaker over the cell-mounted operating cams. Operating interlocks in an incorrect sequence may result in mechanism damage.

Failure to observe this precaution can result in equipment damage.

PRELIMINARY

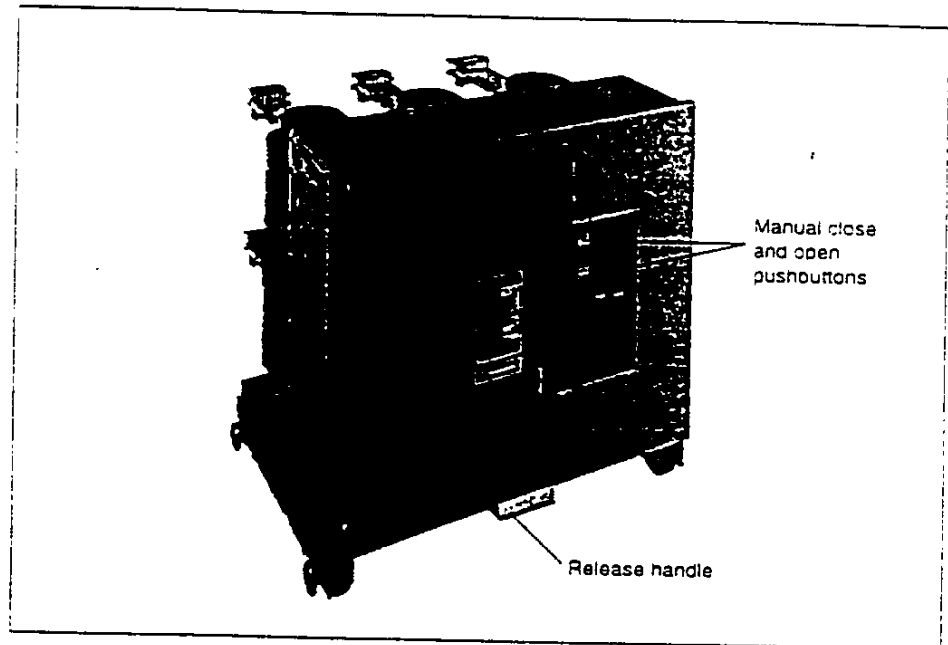

Figure 5: Vacuum circuit breaker Type VR (front view)

Compartment Rating Interlock—These interlocks stop accidental insertion of circuit breakers with incorrect current, voltage, or interrupting ratings into the compartment. The stationary interference brackets are mounted on the floor of the compartment and the moving part of the interlock system is mounted on the underside of each circuit breaker. See figure 4, page 8.

Control Power Receptacle—The circuit breaker control power receptacle is located on the lower right floor of the compartment. The molded insulating receptacle contains 24 contacts and two tapered guidepins. The control power can be connected in the *test* position by rotating the handle and pulling it forward.

Ground and Test Unit Dummy Circuit Breaker Interlock—Each circuit breaker cell is equipped with a ground and test unit (G & T) and dummy breaker permissive interlock. G & T and dummy breakers that are not equipped with the required ground and test unit interlocks cannot be inserted into the circuit breaker cell. The permissive interlocks are located beside the position interlock (figure 4, page 8) on the circuit breaker cell floor. Refer to the specific G & T and dummy breaker instruction bulletins.

Primary High Voltage Contacts—The primary main contacts are housed in a "bell" assembly (figure 7, page 12) consisting of insulating tubes extending toward the front. The current transformers are mounted on the tubes, which are covered at the open end by the shutter when the circuit breaker is in the *test* or *disconnected* position or is withdrawn from the cell. The "bell" assembly is furnished with molded fiberglass polyester tubes as standard, but may also be equipped with porcelain tubes.

Current Transformers—Bushing-type single- or multi-ratio current transformers (figure 7, page 12) can be mounted around either the top or bottom insulating tubes. A maximum of four current transformers, depending on accuracy, can be mounted per phase—two on line, two on load.

Shutters—Two steel shutters (figure 8, page 13) are mounted directly in front of the primary high voltage contacts. Shutters bar incidental contact with the primary high voltage contacts. The shutters move with a rotary motion, actuated by the racking mechanism. See Figure 4, page 8.

Barrier—A barrier in front of the shutter and “bell” assembly and CT’s is designed to stop accidental contact with any live part.



WARNING

HAZARD OF PERSONAL INJURY OR EQUIPMENT DAMAGE.

Disconnect power to both line and load connections before removing the barrier for maintenance or repair.

Failure to observe this precaution can result in severe personal injury or death!

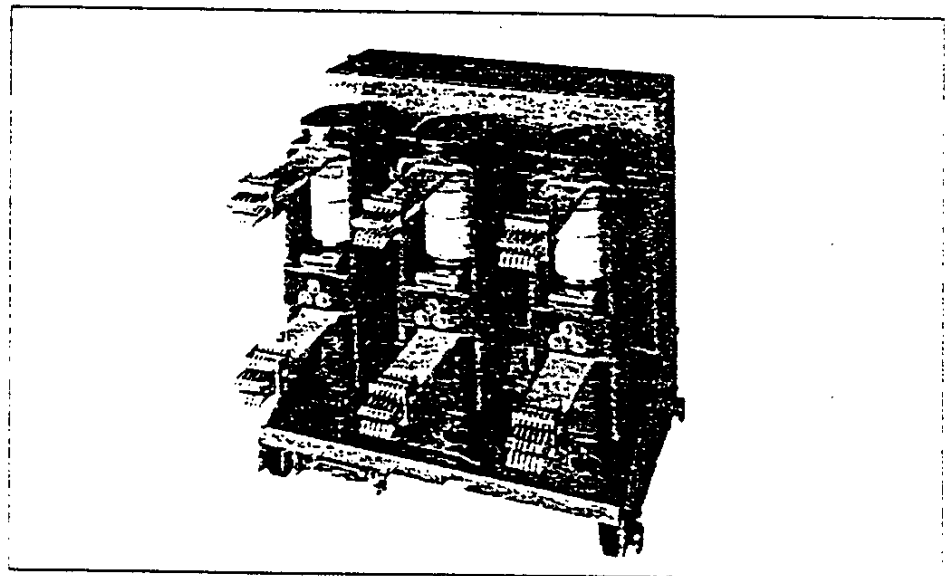

Figure 6: Vacuum circuit breaker Type VR (rear view)

PRELIMINARY

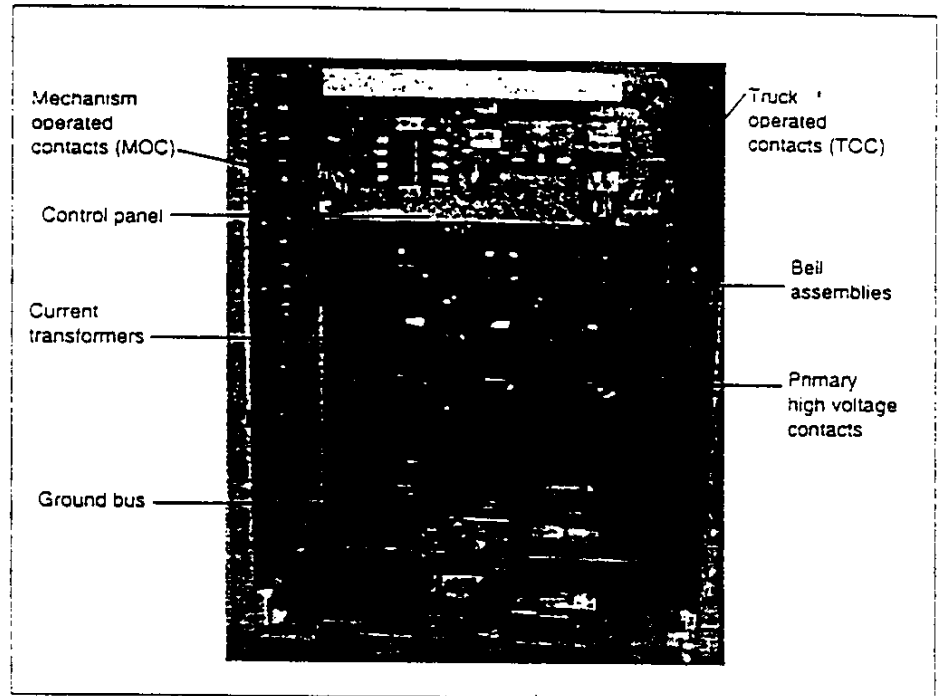

Figure 7: Circuit breaker cell—shutter forced open

Cell Interlock—A cell key interlock (figure 4, page 8) is provided in each circuit breaker cell for locking a circuit breaker out of the *connected* position. The cell interlock is located in the center of the cell floor and has padlock provisions as standard. It can be equipped with a key interlock when specified by the user. The cell interlock prevents racking the circuit breaker into the *connected* position. A circuit breaker can be stored in the *test/disconnected* position with the cell interlock locked.

Ground Contact Bar—A ground contact bar is located on the bottom of the circuit breaker cell. It is directly connected to the main ground bus. A mating set of sliding contacts is located on the underside of the circuit breaker. The contacts engage before the circuit breaker reaches the *test* position and stay continuously grounded to the *connected* position.

Mechanism Operated Contacts (MOC)—Optional—Mechanism operated contacts are compartment-mounted auxiliary contacts operated by the circuit breaker mechanism (figure 7). Like circuit breaker mounted auxiliary contacts, they indicate whether the circuit breaker is in the open or closed position. They operate in both the *connected* and *test/disconnected* positions.

The MOC unit is mounted on the left side of the circuit breaker cell. It is operated by a mechanism that is driven vertically by a roller on the left side of the circuit breaker.

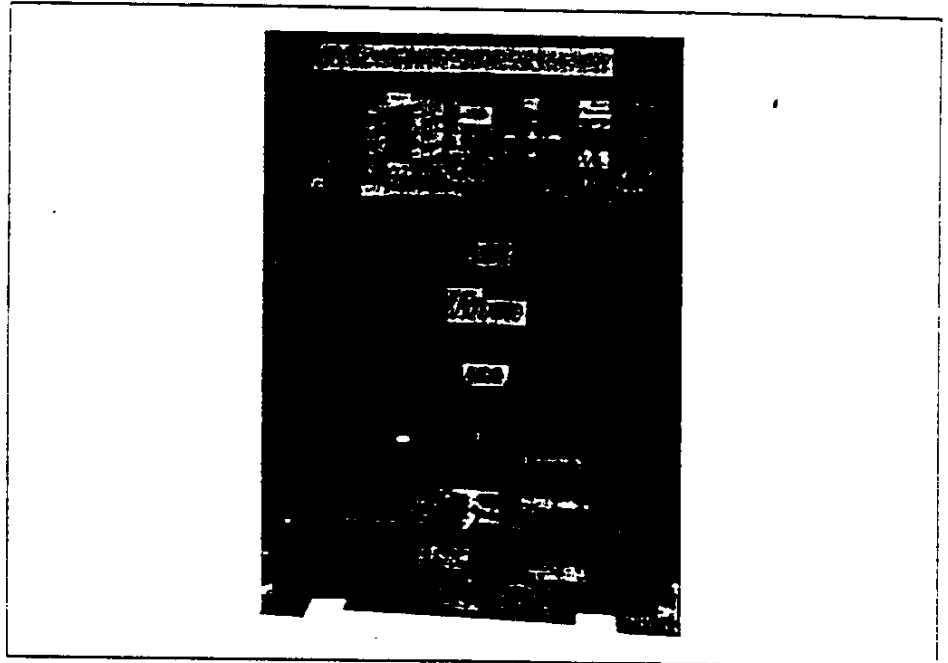

Figure 8: Circuit breaker cell with barrier

Truck Operated Contacts (TOC)—Optional—Truck operated contacts are used to indicate the physical position of the circuit breaker in the compartment (figure 7). They indicate whether the circuit breaker is in the *connected* or *test/disconnected* position.

The TOC unit does not distinguish between the circuit breaker being in the *test/disconnected* position or withdrawn completely from the compartment.

The TOC unit is mounted on the right side of the horizontal steel barrier in the top of the circuit breaker cell. It is operated by a spring-loaded lever. This lever is activated, just before the circuit breaker reaches the operating position, by a pin on the upper right side of the front cover of the circuit breaker.

VT, CPT, and Fuse Drawout Units

The voltage transformer (VT), control power transformer (CPT), and fuse drawout units are self-contained drawers (figure 11, page 15) which roll on two sliding extension rails from the *disconnected* to the *connected* position. The drawer front panel is recessed behind the front door in the *connected* position. It is held in place by two thumbscrews.

An insulating barrier (figure 12, page 15) divides the compartment. The stationary contacts (figure 12) and associated high voltage parts are mounted behind the barrier. Floating, self-aligning line contacts engage the moving contacts as the drawer is inserted into the *connected* position. As the drawer is withdrawn, a static ground contact mounted on top of the compartment grounds the primary connection.

PRELIMINARY

Drawout Voltage Transformer Compartment—Voltage transformers supply voltage indication for metering and relaying purposes. Primary current limiting fuses are mounted on each voltage transformer. Secondary sliding finger-type contacts (figure 9) are mounted on the front left side of the drawer and engage fixed compartment mounted contacts in the *connected* position. Secondary fuses for the voltage transformers are located in the front compartment.

Drawout Control Power Transformer Compartment—The control power transformer (CPT) supplies control voltage for circuit breaker closing, capacitor trip charging, and miscellaneous station auxiliary power functions. The transformer is sized for the specific order requirements; do not add arbitrary non-specified loads after installation. The maximum capacity of the CPT in a drawout unit is 15 kVA.

The CPT, its primary current limiting fuses, and secondary molded case circuit breaker are mounted on the drawer and are withdrawn as an assembly. The secondary circuit breaker handle must be in the *off* position in order to withdraw or insert the drawer. To release the latch, push the secondary circuit breaker handle to the left (*off* position). To engage the latch, push the secondary circuit breaker handle to the right (*on* position) after returning the assembly to the *connected* position.

Each drawout control power transformer is equipped with a padlock provision (figure 10) which locks the unit in the engaged position.

Secondary sliding finger-type contacts are mounted on the front left side of the drawer. They engage fixed mounted contacts in the *connected* position.

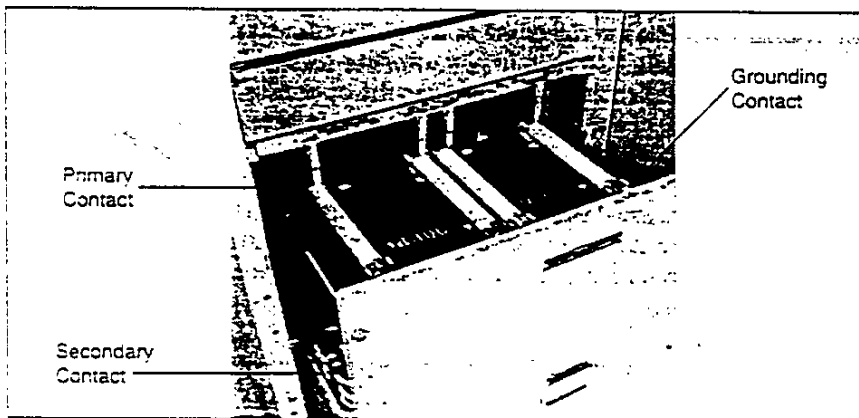

Figure 9: VT drawout

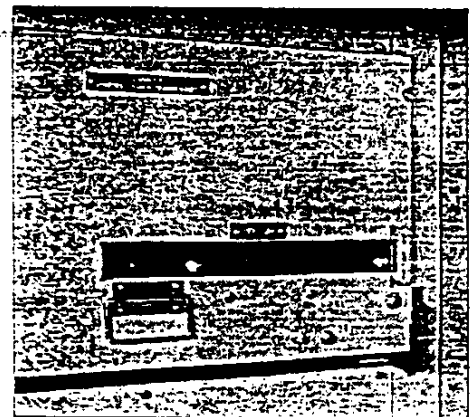

Figure 10: Control power transformer—secondary circuit breaker interlock

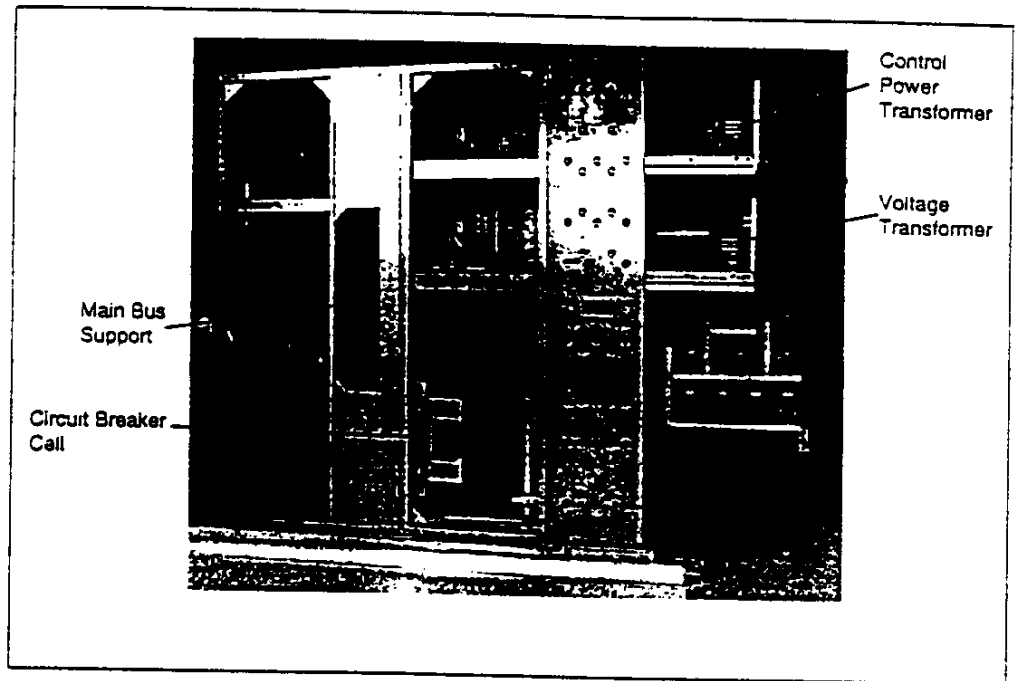

Figure 11: Drawout units in withdrawn position

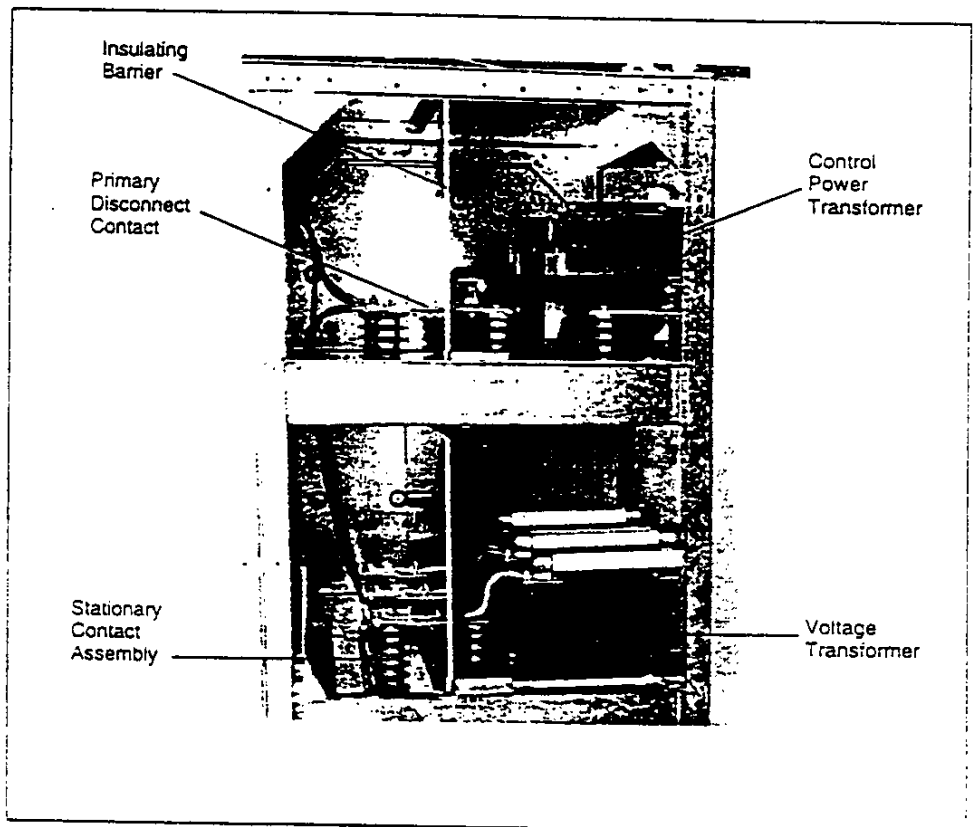

Figure 12: Drawout units in connected (operating) position

PRELIMINARY

Drawout Fuse Compartment—Drawout fuses are provided for fixed mounted control power transformers. Fixed mounted CPTs are supplied when three-phase control power is required or control power requirements exceed 15 kVA. The current limiting fuses are mounted in the drawer and withdrawn as an assembly.

The fuse drawout is interlocked with the secondary circuit breaker by a key interlock system. One interlock locks the drawout in the *connected* position; a second interlock allows closing of the secondary circuit breaker only when the drawout is in the *connected* position. The secondary circuit breaker with interlock is mounted above or below the drawout unit.

Main Bus Compartment

The main bus compartment (figure 3, page 7) is located in the center of the switchgear. It is isolated from other compartments by removable metal access plates. The main bus compartment is accessible from the back (figure 13) through the cable compartment and from the front (figure 3) through the circuit breaker cell.

1200A and 2000A main buses are available in aluminum or copper. The 3000A is always copper.

Each busbar has fluidized bed epoxy insulation rated for 105°C operation. Flame- and track-resistant glass polyester barriers are used to separate the bus compartments between adjacent cells. Optional porcelain inserts are available.

Polyvinyl chloride boots insulate the connection in the main bus compartment, overlapping the epoxy insulation on the busbars. The busbar insulation and boots form an integral insulating system for the equipment to meet its dielectric ratings. The busbar insulation must not be damaged or modified. Boots must be in place before operating the equipment.

Cable Compartments

Each circuit breaker in a vertical section has a separate cable compartment, accessible by removing a steel cover on the back. Insulated load connectors are provided for terminating cables. As standard, the load connectors are punched for terminating two cables per phase with a NEMA 2-hole pattern. If requested, lugs can be provided by Square D. Tape and associated material for insulating cable terminations is not supplied as standard.

A ground bus (figure 13) in the cable compartment has lugs on each end for the assembly ground. This ground bus connects to each circuit breaker compartment ground bar and to the individual ground bar in each cable compartment, providing a common ground for the assembly. All instrument transformer, metering, and relaying grounds are also connected to this common ground system.

Conduit must enter the cable compartments, in the areas shown on the customer drawings, from either the top or bottom of the cable compartment. A removable steel cable pull box (figure 13) is provided to isolate cables when two circuit breakers are installed in one vertical section.

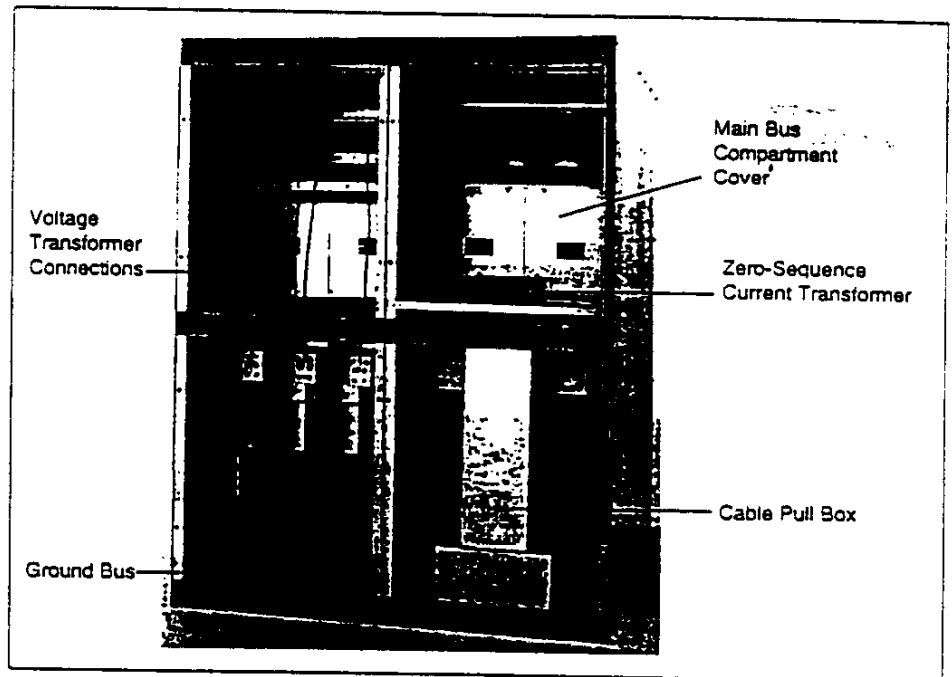

Figure 13: Two-bay structure—rear view

NOTE: Conduit should be stubbed in the concrete as part of the site preparation *before* the assembly is installed, but top entrance conduit must be installed *after* the assembly is in place. The top covers can be removed, punched to fit the conduit, and put back in place.

The front conduit area is for the bottom circuit breaker when all cables enter from below, and for the top circuit breaker when all cables enter from above. This cable pull box may be removed to install the rear cables first. When required, zero-sequence current transformers (figure 13) are conveniently located in each cable compartment.

Various cable termination systems are used; these are detailed on the plans and specifications. Solderless or compression lugs can be supplied on the load connectors. Potheads are mounted on grounded support brackets. The compound and tape for their internal connections are shipped in a container with the other miscellaneous parts. Tape and insulating material necessary for completing the field connection at the bus pad is not supplied with the assembly.

Surge Arresters

Surge arresters are furnished only when listed in the user's specifications. The vulnerability of the incoming and outgoing lines to lightning strikes or other high voltage transient conditions determines their type and justification. Surge arresters, when specified, are mounted in the incoming and outgoing cable compartments.

PRELIMINARY

SECTION 5—OPERATING INSTRUCTIONS

Circuit Breaker—Circuit Breaker Cell Interlock System

The circuit breaker and the circuit breaker cell are equipped with an interlock system.

The interlocks are designed to:

- Not allow the circuit breaker to be pushed into the cell when the circuit breaker is closed.
- Not allow the circuit breaker to be closed while it is moved between the test and operating position.
- Not allow the circuit breaker to be moved from the operating position when it is closed.
- Discharge both the closing and trip springs when the circuit breaker is being moved from the circuit breaker cell.

Circuit Breaker Operation

Racking Mechanism—The racking mechanism moves the circuit breaker from the *test/disconnected* position to the *connected* position and back to the *test/disconnected* position.

Push the circuit breaker into the compartment to the *test/disconnected* position, and the disconnect release handle engages (figure 5, page 10).

Insert the racking handle and rotate it clockwise to rack the circuit breaker into the *connected* position. When in the *connected* position, the circuit breaker's forward motion stops.

With the door closed, the position indicator (figure 4, page 8) shows if the circuit breaker is in the *test/disconnected* position, in *transport*, or in the *connected* position. With the door open, two arrows on the left hand rail show if the breaker is in the *test/disconnected* position or in the *connected* position.

To remove a circuit breaker from the *connected* position to the *test/disconnected* position, open the circuit breaker electrically with the compartment door closed, and with the racking handle, move the circuit breaker to the test position.



WARNING

HAZARD OF BODILY INJURY OR EQUIPMENT DAMAGE.

When the switchgear is energized, always open and close the circuit breaker, and rack the circuit breaker from one position to another with the door closed.

Never use force to move the circuit breaker inside the circuit breaker cell. If a mechanism is not operating smoothly, look for the cause.

Failure to observe these precautions can result in severe personal injury, death, or equipment damage!

Control Power Plug—In normal operation, the Control Power Plug automatically connects and disconnects as the circuit breaker is moved into and out of the connected position.

To test the control system with the circuit breaker in the *test/disconnected* position, rotate and pull the handle of the secondary control power receptacle forward until it can be rotated again and locks the receptacle in position. The circuit breaker can now be electrically operated the same as in the *connected* position. After checking all electrical functions, push the receptacle back in its normal operating position. Only then, rack the breaker into the operating position.

Disconnect Position Latch—The disconnect position latch prevents the circuit breaker from rolling out of the compartment in the *test/disconnected* position. To remove the circuit breaker from the cell, pull the release handle of the breaker.

Manual Spring Charging Mechanism—In normal operation, when the control plug is engaged, the motor automatically charges the circuit breaker closing springs. The springs can also be charged manually, using the manual spring charging mechanism. This feature is provided for testing and maintenance purposes, and for emergency operating conditions.



CAUTION

HAZARD OF EQUIPMENT DAMAGE.

Never manually close a circuit breaker in the *connected* position unless the opening source of power and protective relays are connected and operable.

Failure to observe this precaution can result in equipment damage.

Manual Close and Open Pushbuttons—Manual close and open pushbuttons are located at the front of the circuit breaker (figure 5, page 10). These pushbuttons operate the circuit breaker whether the circuit breaker is charged manually or electrically; use them only when testing the circuit breaker during start-up or maintenance.



CAUTION

HAZARD OF EQUIPMENT DAMAGE.

When the switchgear is energized, never use the manual open and close pushbuttons on the front of the circuit breaker. Use the control switch with the front door closed.

Failure to observe this precaution can result in equipment damage.

PRELIMINARY

SECTION 6—INSTALLATION

Site Preparation

Good site preparation is absolutely necessary. It eliminates costly and time-consuming installation problems and ensures proper, reliable operation of the assembly. Carefully compare the plans and specifications with the customer drawings provided to be sure the following conditions are met:

- Provide adequate ventilation at all times so the ambient temperature around the assembly does not exceed 104°F (40°C). Clean, dry, filtered air should be supplied.
- Provide adequate lighting in both the front and back aisle spaces. Also provide convenience outlets in both areas for hand tool use.
- Provide adequate floor drains.
- Route sewer, water, and steam lines so they do not pass over or near the assembly. Dripping liquids may damage the insulation.

Foundation

The switchgear must be installed on a flat, level surface. Square D recommends installing the switchgear on a concrete pad leveled to 1/16 inch (1.6 mm) in any square yard, with steel channels (figure 14) installed in the pad (figure 15) for anchoring the switchgear.

Pour a 7-foot wide aisle space in front of the mounting pad, flush with and finished to the same tolerance as the mounting pad. This level surface is necessary for the circuit breaker lift truck and for inserting the circuit breakers into the bottom compartment.

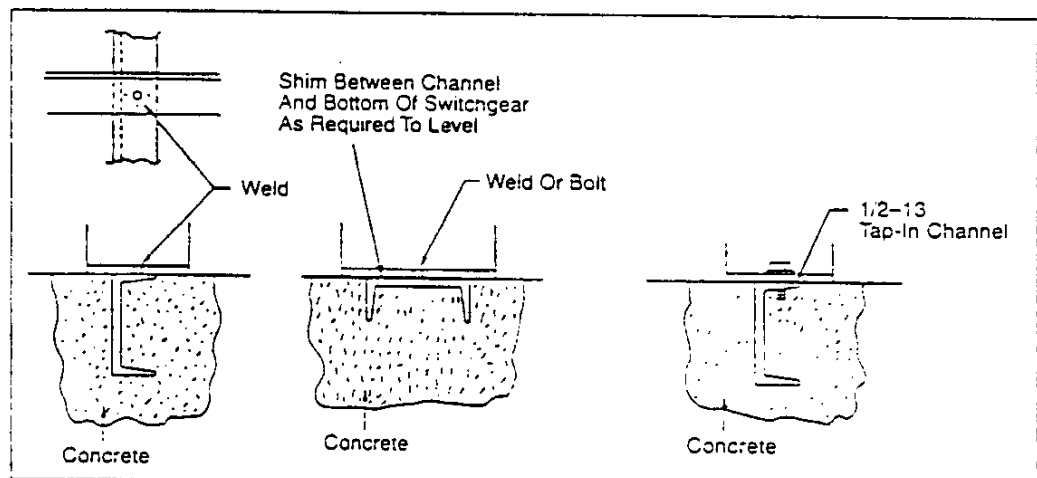

Figure 14: Switchgear mounting floor channels

PRELIMINARY

Bulletin 6055-30
August 1995

NOTE: A minimum of 3 feet (76 mm) is *absolutely* necessary on the right end facing the front of the line-up. This space is necessary for door clearance when removing the circuit breakers.

Conduits should be stubbed a maximum of 1 inch (25 mm) above floor level. To simplify moving the switchgear into place, keep the conduit flush with the surface of the floor. Position the conduit very accurately so that there is no mechanical interference with the assembly frame. Eliminate continuous loops of reinforcing rod or structural steel around any single conductor of a three-phase power circuit.

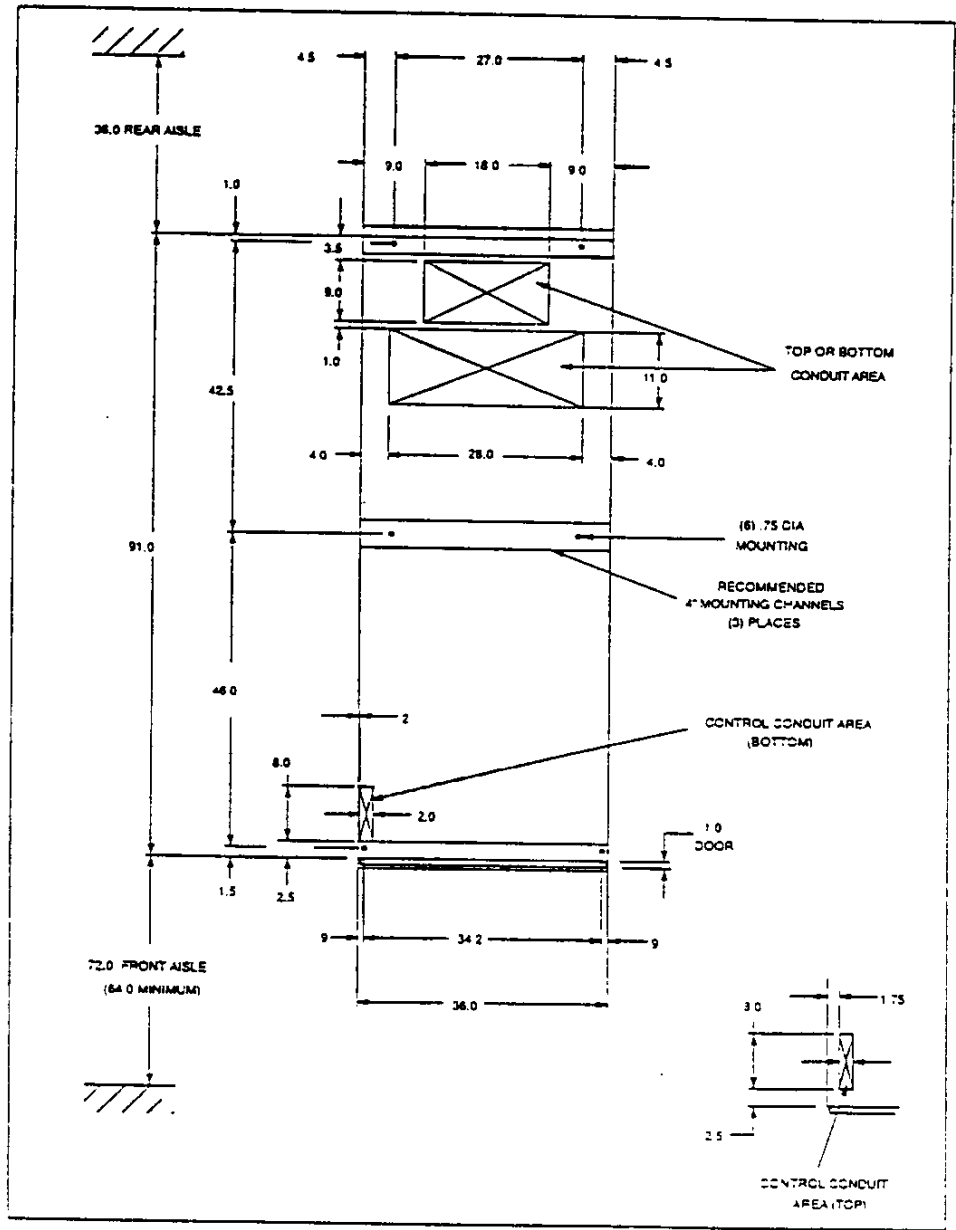

Figure 15: Floor plan

PRELIMINARY

Switchgear Installation

Two-high 4.76–15.0 kV metal-clad indoor switchgear may be shipped in one or more shipping sections, depending on the number of cells in the assembly.

Before installing each section, refer to the customer drawings and section markings to ensure proper alignment.

When installing two shipping sections, install first the section that allows the most maneuverability before installing the second section.

When more than two shipping sections are involved, carefully measure the conduit spacings and compare with the customer drawings. Cumulative error in conduit location may require starting with the center shipping section and working toward either end. If the conduits are properly located, install first the end shipping section that allows the most maneuverability before installing the additional sections.

Sweep the pad before installing any sections. Move the section(s), with skid(s) intact, into place. If rollers must be used, move with the skid in place. Remove the skid only when the switchgear is in proper position on the pad. Lower the first section onto the pad. If necessary, place a 2" x 6" board across the assembly, and pry into place. Do not pry directly on the structure, doors, or covers. Before proceeding, check that:

- the conduits are in the center of the cutouts
- the back of the unit is perpendicular to the pad and has proper clearance
- the mounting holes line up with the holes in the mounting channels

Level each section before installing the next; install steel shims, when necessary, between floor channels and switchgear. After leveling a section, bolt it to the previously installed section(s) before proceeding. If the sections do not fit snugly together, remove the most recently placed section with the crane. Check for obstructions and try again. Do not attempt to pull sections together with the hardware.

All shipping sections must be bolted together in place before bolting or welding sections to the channel sills, or installing the horizontal main bus.

After all the sections are level and bolted together, again check that all shipping sections are in their correct position per the job drawings. If they are, weld or bolt the switchgear to the pad. If bolting, use 1/2-13 bolts.

Install the main bus at the shipping break only after all sections are securely anchored in place and no additional movement of the assembly will occur.

Busbar extensions for shipping breaks are shipped with the miscellaneous items.

A typical main bus assembly is shown on page 23 (figure 16). The side and rear views (figure 16) of the assembly show the general arrangement of the main bus and riser. The side (figure 17) and top (figure 18) views show the different bus connections and the orientation of the filler and splice plates. When aluminum bus is furnished, some of the circuit breaker connections and splice or filler plates are copper.

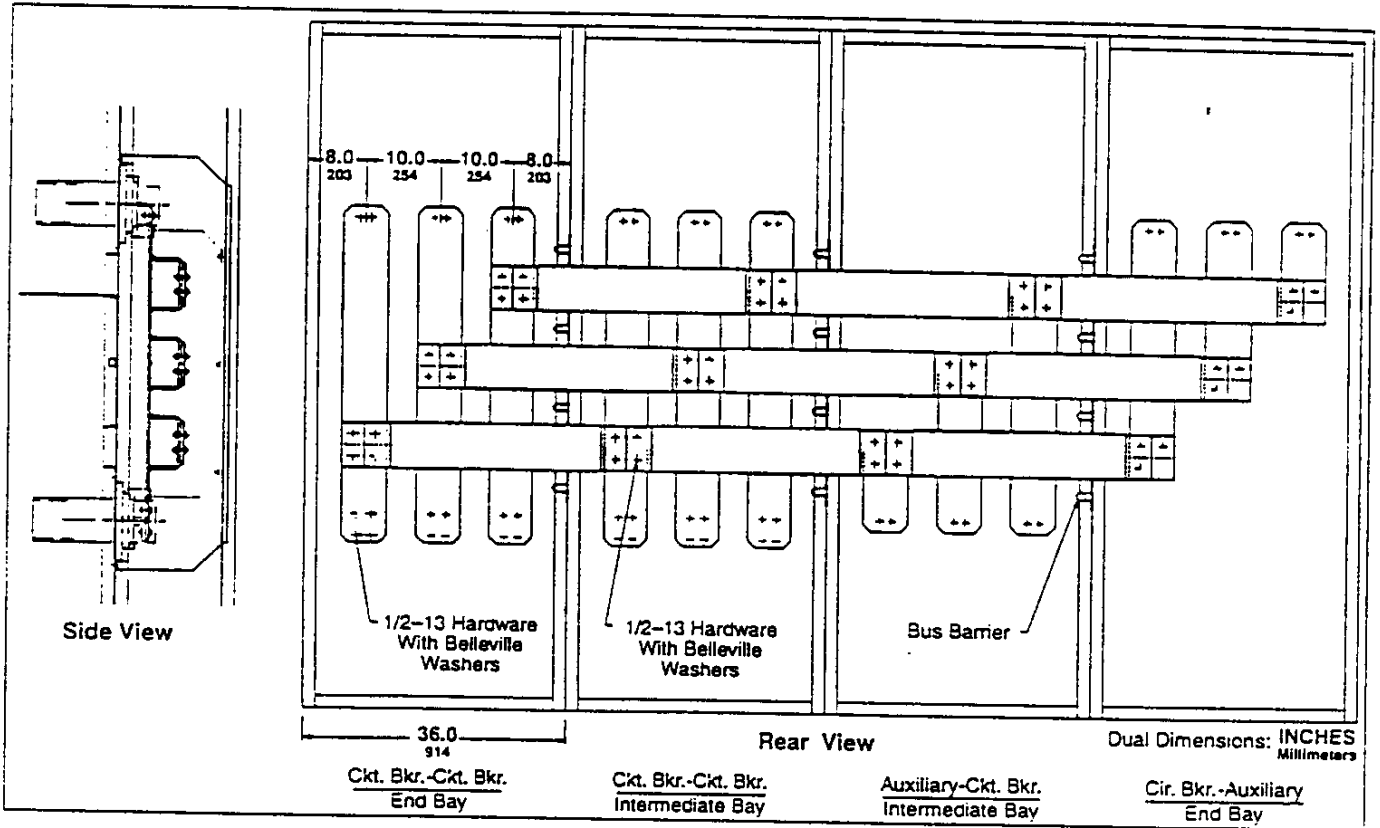

Figure 16: Main bus assembly

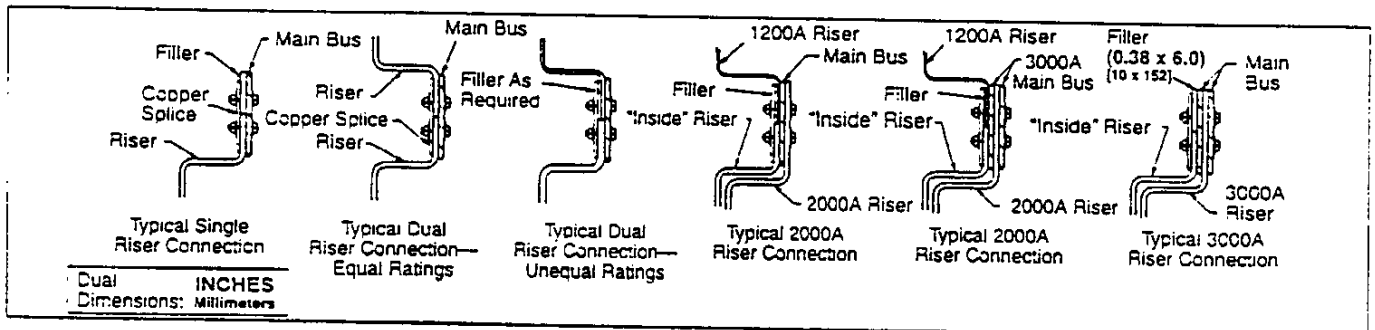

Figure 17: Main bus connections—side view

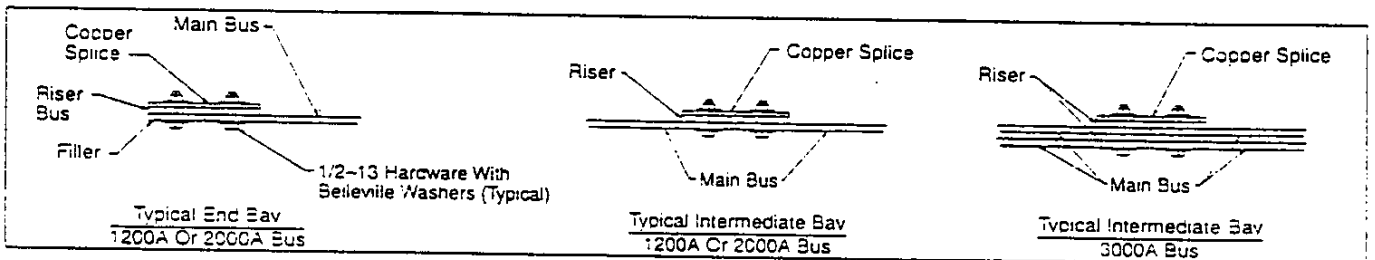

Figure 18: Main bus connections—top view

PRELIMINARY

The standard switchgear is furnished with fiberglass-polyester bus barriers between bays. Porcelain "pass-throughs" are available as an option (figure 19).

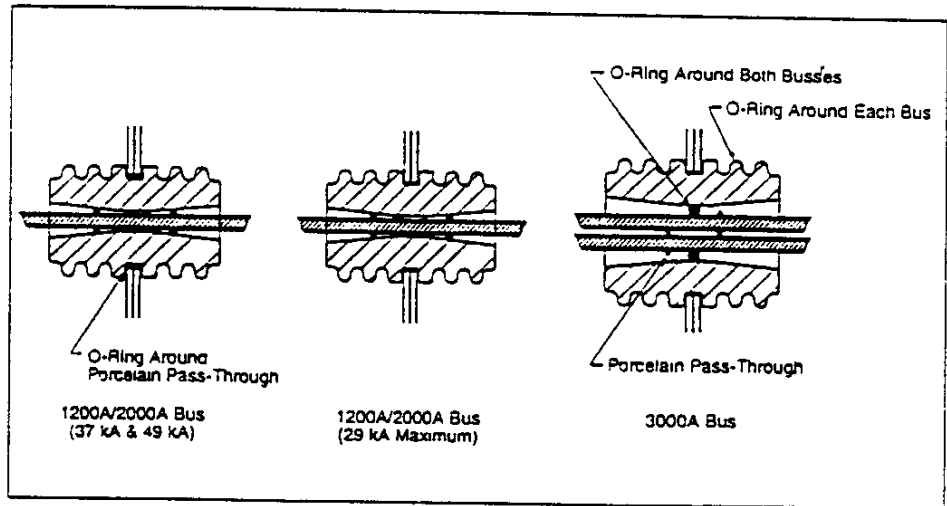

Figure 19: Main bus pass-through, porcelain—optional

For porcelain pass-throughs only, O-rings must be installed inside the pass-throughs to cushion the busbars under short circuit conditions.

An easy way to install two busbars is to place the larger O-ring around both bars at the correct distance from the end (figure 19), and the smaller rings around each bar approximately 1" (25 mm) on each side from the large O-ring. Next, slide both bars into the porcelain (one end of the porcelain may have a larger opening).

When busbar on stand-off insulator installation is required on shipping sections, refer to figure 20. Fiberglass-polyester washers and O-rings must be installed as shown.

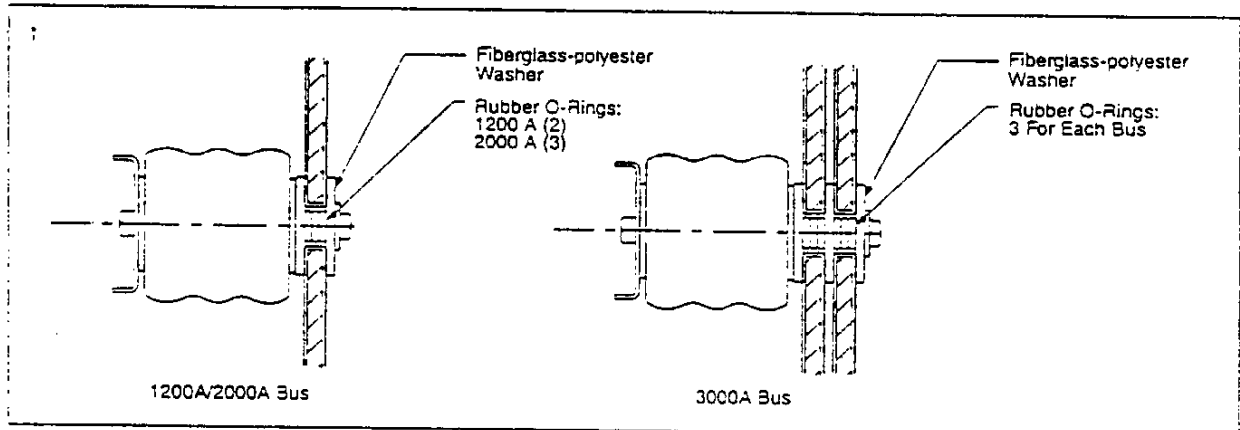

Figure 20: Stand-off bus support

Remove the main bus covers and the insulating boots. Install one phase at a time by sliding the busbar through the bus barriers and loosely bolting the horizontal bus to the vertical bus. Do not bend or force the bus to make this connection. The through bushings and the divided insulating barrier may be loosened if necessary. They have sufficient clearance and adjustment to compensate for minor field misalignment of shipping sections. Tighten the bolts holding the busbar joints only after all three busbars are in place and properly fitted. Use a torque wrench to ensure that the bolts for busbar connections are tightened in accordance with the table below.

Table 1
Bolt Torque

Bolt Size	Mechanical Joints	Busbar Connections
1/4-20	7 lb-ft (9.45 N•m)	—
5/16-18	14 lb-ft (18.91 N•m)	—
3/8-16	21 lb-ft (28.36 N•m)	30 lb-ft (40.52 N•m)
1/2-13	42 lb-ft (56.72 N•m)	55 lb-ft (74.28 N•m)

Connect the ground bus splice at each shipping section. Remove the hardware and position the splice plate, then replace and tighten hardware on both ends. The ground bus must be connected for proper operation of relaying and instrumentation, and for personnel safety.

Consult the customer wiring diagram for reconnection of wiring at the shipping break. Each wire is identified and has been previously connected during assembly and testing at the factory. If the identification is missing or blurred, ring-out before connecting to avoid control circuit and instrument panel problems at start-up.

With all primary and control power circuits de-energized, insert each circuit breaker into the *connected* position of its respective circuit breaker compartment. Observe the operation of the ground contacts, shutters, and disconnect position latch.

Remove each circuit breaker from its compartment. Open the shutters and check that tracks made in the contact grease by the fingers of the main disconnects extend back a minimum of 1/2" (13 mm) from the front edge of each bar. Ensure that the ground shoe leaves tracks on the ground bus.

Do not force circuit breakers into circuit breaker compartments; compartment rating interlocks prevent inserting circuit breakers into incorrect cells.

Withdraw the drawout control power fuse drawer and the drawout voltage transformer drawer; observe their operation. Check that the static ground operates properly, and that the primary and secondary contacts make proper contact.

PRELIMINARY

High-Potential Testing

Before making external power connections, high-potential (hi-pot) test the bus and circuit breakers as an assembly. Before conducting this test, take the following steps:

- Disconnect lightning arresters.
- Withdraw the control power transformer drawer, the voltage transformer drawer, and drawout fuse drawer (if provided).
- Place each of the circuit breakers in its proper circuit breaker compartment in the *connected* position. Charge their springs manually, then close each circuit breaker by using the manual closing lever.

A reliable transformer-type tester with a built-in voltmeter and milliammeter must be used for hi-pot testing. Capacitor loaded bench-type testers with neon bulb indicators do not have sufficient capacity to give reliable results.

The table below gives normal test values for dry, clean, new assemblies. Field hi-pot tests are made at 75% of factory test voltages in accordance with ANSI standards.

Table 2
One Minute High-Potential Test ①

Assembly Rated Maximum Voltage	Factory Test Voltage	Field Test Voltage	
		AC	DC
4.76 kV	19 kV	14 kV	20 kV
8.2 kV	36 kV	27 kV	38 kV
15 kV	36 kV	27 kV	38 kV

① All voltages are 60 Hz rms symmetrical.

If satisfactory results are not obtained, locate the problem, correct it, and rerun the test before proceeding. If the test is successful, the power cables, ground wires, external wiring, and battery (if supplied) can be connected to the assembly.

Phasing

Per NEMA standards, all bus within the switchgear is phased A-B-C left to right, top to bottom, and front to back when viewing the assembly from the front (the circuit breaker compartment side). If, for any reason, the bus must be phased differently, the different phase will be identified on the bus with a label.

Cable Connections

Use extreme care when making up all types of cable terminations, as terminations are critical to the successful operation of the electrical distribution system. Avoid sharp turns, edges, or corners in order to prevent damage to the cable insulation. Follow the cable manufacturer's recommendations for minimum bending radius. These instructions will vary from manufacturer to manufacturer.

Solderless or compression-type cable lugs are the most common method for connecting power cables to metal-clad switchgear. When making the

terminations for each type of power cable, follow the cable manufacturer's instructions. After the cable connections are made, insulate them as follows:

1. Place 3M brand Scotchfil putty around the lugs and bolts to reduce the concentrated field created by their irregular shapes (figure 21). Apply a layer of No. 13 semi-conducting tape over the Scotchfil. Half-lap the tape, which must extend onto the conductor. Do not extend the tape up over the bus epoxy insulation. Apply Scotch brand No. 130C tape over the No. 13 tape. Half-lap this tape for two layers on 4.76 kV installations, and four layers on 8.25 kV and 15.0 kV installations. For 4.76 kV applications, extend this tape 1-1/2" (38 mm) up over the bus insulation and cable insulation; extend the tape 2" (51 mm) for 15.0 kV applications.
2. Apply two layers of Scotch Brand No. 22 tape, extending the tape up over the No. 130C tape in all directions. The tape and other insulating materials for completing these field connections are not normally supplied with the switchgear.
3. When potheads or terminators are supplied for terminating power cables, follow the pothead manufacturer's instructions for terminating the cables in these devices. To facilitate installation of the power cables, the bus side is not taped. After the cables are installed, insulate the pothead-to-bus connections per the cable lug insulation instructions described earlier in this section.

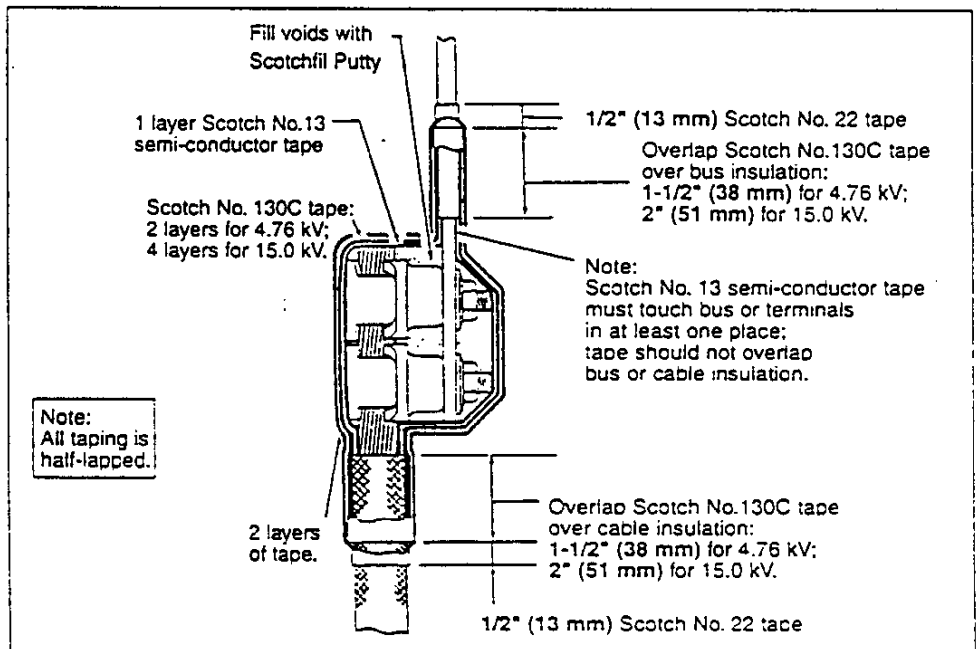

Figure 21: High voltage cable lug insulation

NOTE: The external surface of each shielded cable is at ground potential and must be positioned a minimum of 6" (152 mm) from any live part (even its own pole), including insulated bus bars.

PRELIMINARY

SECTION 7—START-UP

To start up the switchgear, follow these steps:

1. Before the main source of power is connected to the assembly, make a thorough inspection of the system.
2. Vacuum out every compartment. Remove all loose parts, tools, miscellaneous construction items, and litter.
3. Replace all the main bus covers and any other barriers or covers which were removed during installation.
4. Ensure all boots are installed.
5. Install the cable compartment back covers.
6. Connect the battery charger and batteries (if used) to the switchgear control bus per the order drawings.
7. Unblock all of the protective relays and set to the relay schedule. Using a relay tester, verify the settings and electrical operation of each relay.
8. Ensure that the drawout control power transformer (or drawout fuse drawer) has the current limiting fuses in place. *Pull the drawer out to the withdrawn position.*
9. Place all circuit breakers in their compartments in the *test/disconnected* position.
10. Connect a temporary source of low-voltage power to the stationary secondary contact of the control power transformer or any logical point (consult the customer schematic and wiring diagram). Open the secondary circuit breaker and remove the primary fuses.
11. Rack one circuit breaker at a time into the *connected* position, then electrically close and open the circuit breaker with the door-mounted circuit breaker control switch. Open the circuit breaker by temporarily closing the contacts of each protective relay. Reset the targets after each operation and rack the circuit breaker into the *test/disconnected* position.
12. Electrically operate from remote control locations and check the remote indicating lights.
13. Operate all electrical interlocks, transfer schemes, lock-out relays, and other control functions to ensure proper operation.
14. Remove the temporary source of low voltage power and make the permanent connection of low voltage power. Rack all circuit breakers into their *connected* position. Insert the drawout control power transformer, drawout fuses, and drawout voltage transformers into the *connected* position.
15. Check again that trip voltage is available at circuit breaker terminals in each compartment.
16. Energize incoming high voltage circuit(s).
17. Close circuit breakers to initiate service.

SECTION 8—INSPECTION AND MAINTENANCE

Perform inspection and maintenance on the basis of operating conditions and experience. Abnormal operation or conditions may require immediate action, while regularly scheduled inspection and maintenance will depend on when downtime can be tolerated and qualified personnel are available.

DANGER

HAZARD OF BODILY INJURY OR EQUIPMENT DAMAGE.

Perform inspection and maintenance only with the main source(s) of power disconnected and locked open with a "work" lock. Be absolutely sure there is no backfeed through any feeder circuit. Ground the main and feeder circuits before touching the main bus, bus pads, or primary contacts.

Failure to observe these precautions will result in severe personal injury, death, or equipment damage!

Main Bus Compartment

Remove the front and rear covers from each main bus compartment. Inspect the busbars, primary contact supports, and insulating barrier. Check all busbar connections, and torque all 1/2" bolts to 55 lb-ft (74.28 N•m).

Slight discoloration or tarnish of the silver plate is normal and of no concern. Severe discoloration of the silver plate is an indication of an improper or loose contact and overheating. Clean the discoloration from the contact surfaces of the busbar and primary contact. Use an abrasive pad such as Scotch Brite.

Vacuum each compartment to remove dust, spiderwebs, etc. Wipe off the insulation with a clean cloth.

Cable Compartment

Inspect the load connectors, stand-off insulators, primary contact supports, and all accessible cable terminations for indications of insulation deterioration. Clean the silver-plated contact surfaces if necessary. Vacuum each compartment and wipe off all insulation. Replace removable back covers.

Circuit Breaker Compartment

Withdraw each circuit breaker from its compartment, and thoroughly inspect each of the moving mechanisms in the compartment.

The shutters should raise and lower smoothly with no indication of binding, twisting, hesitation, or hang-up. Inspect the shutter hardware; tighten if necessary.

PRELIMINARY

No burn or pit marks should be visible on the primary contacts; they should have a silver-gray appearance, indicating good contact with the circuit breaker separable contacts. Slight discoloration or tarnish of the silver plate on the primary contact is normal and of no concern. Severe discoloration of the silver plate is an indication of excessive heating and should be corrected. Typical causes are:

- poor contact between the circuit breaker separable contacts and the primary contacts
- loose hardware or otherwise improper contact at the bus connection
- severe over-current operating condition for an extended period of time
- internal heating problems in the circuit breaker

Investigate each possible trouble source, correcting the problem once it is determined.

Clean the discoloration and tighten the contact mounting bolts to the proper torque. Inspect the primary contact and support insulators.

No burn or pit marks should be visible on the ground contact; it should have marks indicating good contact with the circuit breaker sliding contacts. Clean the contact surfaces, removing grease and dirt buildup. Inspect and tighten the hardware.

Inspect the stationary control power receptacle, ensuring that the molding is free of cracks, the female contacts are clean, and the assembly is free to move. Clean the front and back surfaces of the receptacle to prevent contamination buildup. Vacuum the compartment, and wipe off the primary contact high voltage insulating tubes and support insulation with a clean, dry cloth.

Lightly lubricate the primary contacts and the ground contacts with Mobilux EP 1, Square D part number 1615-100790.

Lubricate all moving joints (shutters, MOC, TOC, etc.) with Mobilgrease 2S, Square D part number 1615-100950.

Check all terminal block connections for loose hardware and crimp-on terminal conditions. Make certain that the hinge wiring to the door is not frayed and has no insulation damage. Route all wires through the hinge loop.

Circuit Breakers

Consult the individual circuit breaker instruction and maintenance manual for cleaning, adjustment, and lubrication information.

VT, CPT and Fuse Drawout Units

Pull the drawer to the fully withdrawn position. Inspect the moving and stationary primary and secondary contacts and the static ground contacts. Clean the contact surfaces, removing any burn or pit marks if required. Use an abrasive pad such as Scotch Brite.

Remove the current limiting fuses, and inspect the fuse clip and fuse contact

PRELIMINARY

Bulletin 6055-30
August 1995

surfaces. Inspect the transformer for indication of insulation deterioration. Tighten all hardware, including the secondary contact wiring terminals.

Vacuum the compartment and drawer. Wipe off the insulation and control power transformer with a clean, dry cloth.

Lightly lubricate the moving primary and secondary contacts and fingers with Mobilux EP 1, Square D part number 1615-100790.

Lubricate all rollers and sliding parts with Mobilgrease 28, Square D part number 1615-100950.

Inspect the interlock mechanism for proper operation. Replace the current limiting fuses, but leave the drawer in the withdrawn position until all the inspection and maintenance is completed.

Insert all of the circuit breakers to the *test/disconnected* position with their secondary control power plugs engaged, and close the compartment doors. Connect the control power source.

Close the main source of power, and operate each circuit breaker electrically in the *test/disconnected* position.

If all controls are functioning properly, disconnect the secondary control plugs. Rack the circuit breakers into the *connected* position. Close the circuit breakers and resume normal operation.

PRELIMINARY

SECTION 9—ACCESSORIES

Circuit Breaker Lift Truck

One circuit breaker lift truck is required for each two-high line up. The cradle is raised and lowered by a self-braking worm and pinion drive system with a winch and wire cable. No ratchet release or locking is required due to the automatic load-retaining clutch feature. Rotating the handle clockwise raises the cradle; rotating the handle counterclockwise lowers the cradle.

Push the lift truck toward the circuit breaker compartment so the cradle is square with the front of the circuit breaker cell. Raise the cradle until the hook brackets on each side of the cradle clear the blocks on each side of the circuit breaker cell rails. Lower the cradle until the hook brackets lock over the blocks on each side of the circuit breaker cell rails. The circuit breaker can now be moved easily into and out of the cell.

To remove the circuit breaker from the cell, secure the circuit breaker on the lift truck using the securing means provided. Raise the cradle until it clears the blocks on each side of the circuit breaker cell rails. Remove the lift truck and circuit breaker from the cell and lower the cradle to the floor.

To remove the circuit breaker from the lift truck, disconnect the safety cable from the front of the circuit breaker. Then, push the circuit breaker slightly toward the back of the cradle and press the lever on the side of the cradle while rolling the circuit breaker off of the cradle.

Test Cabinet—Optional

An optional wall-mounted test cabinet (figure 22) is furnished when listed in the user's specifications.

The test cabinet consists of a small enclosure with a *power on-off* toggle switch, white *power on* indicating light, red *circuit breaker closed* indicating light, green *circuit breaker open* indicating light, *close* and *open* push buttons, and an 8-foot cable with a secondary control receptacle which can be plugged directly into the circuit breaker control plug. Refer to the customer drawings for the external power connections and requirements necessary for the cabinet. A convenient terminal block is provided inside the test cabinet for these connections.

Ground and Test Device—Optional

Two types of ground and test devices are available:

- manual
- automatic

Ground and test devices are safety devices, typically used for:

- grounding of circuits during maintenance periods
- connection points for applying voltage for hi-pot testing and cable testing
- access to both lineside and loadside circuits for phase sequence testing

A complete description, operating instructions, and maintenance information is included in a separate ground and test devices instruction bulletin.

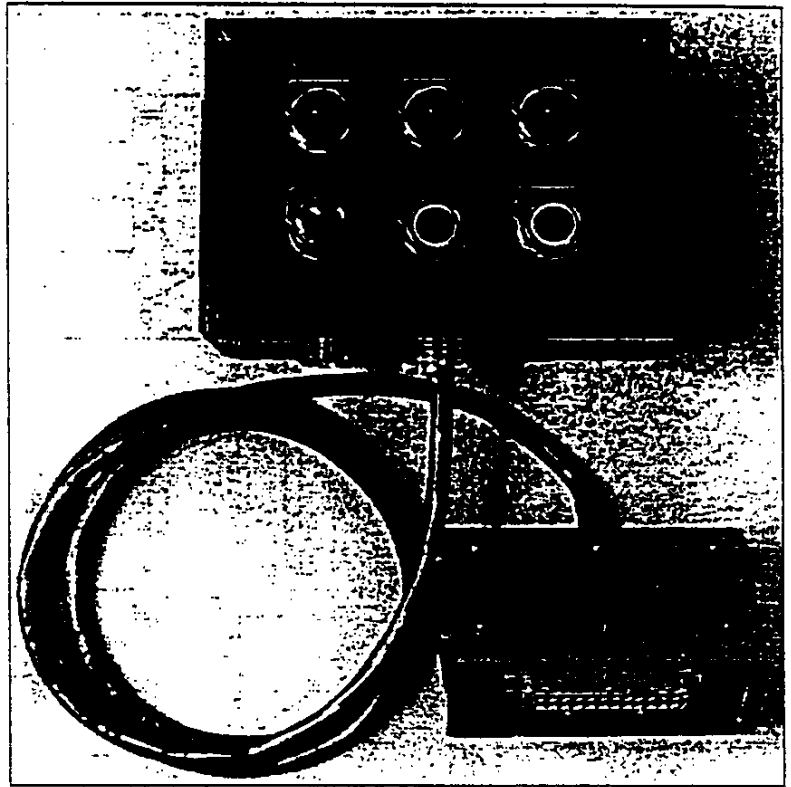

Figure 22: Wall-mounted test cabinet—optional

PRELIMINARY

SECTION 10—OUTLINE

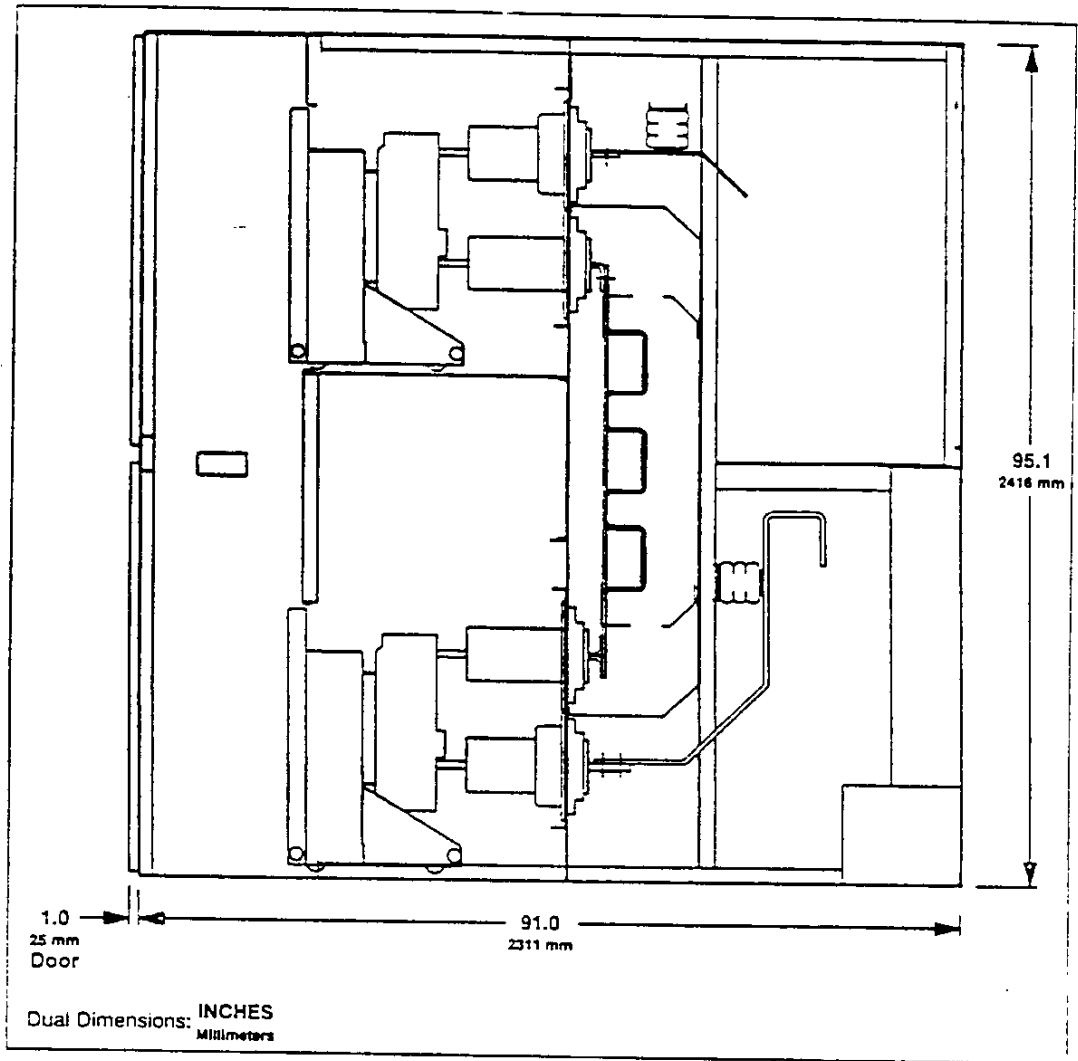

Figure 23: MASTERCLAD indoor switchgear outline

PRELIMINARY

Square D Company
330 Weakley Road
Smyrna, TN 37167 U.S.A.

Order No. 5055-30



Part No. 5055-30 BEE
Printed in USA