

# Plugging Switch for Type UR Tap Changer

## INSTRUCTIONS

### GENERAL

This switch is used to close a plugging circuit to stop the tap changer operating motor. It is designed for use with Westinghouse type UR tap changers and regulators only. It must not be applied to any other apparatus without consulting the manufacturer.

Rotation of the motor in either direction causes this switch to close one or the other set of its contacts. These contacts, when properly connected to the motor control circuit, set up a circuit to plug the motor to a stop when a tap change has been completed.

### CONSTRUCTION AND OPERATION

Refer to Fig. 1. The rotating assembly R is attached to the motor shaft, and by friction drive causes lever L to rotate and close contacts XR or XL.

The rotating assembly is pictured in Figs. 2 and 3. The switch shaft SH is keyed to the motor shaft. The spool assembly SP consists of a threaded portion with a notched end-piece and an oilite friction disc O on each end. This spool is free to spin on shaft SH. The stainless steel friction disc D has a tongue which engages a keyway in the extension of shaft SH so disc D rotates with SH.

Spool SP is driven by friction, which is obtained between the shoulder on shaft SH and the oilite friction disc O on the left end of SP; also between the friction disc D and the oilite friction disc O on the right end of SP. Pressure to produce the friction is applied by compression spring S. This friction drive causes movement of SP in the direction of rotation of the motor shaft.

On the threaded portion of SP is the nut N to which are fastened a stop ST and the lever L. The tendency of the nut N to rotate with SP is limited by the guides G (See Fig. 1). As SP rotates, N travels along the screw. As it approaches the end of the threaded portion of SP, stop ST engages a notch in the end-piece of SP. This halts the axial travel of N and applies to Nut N the

torque exerted by the friction drive. This torque then forces lever L against the stop G and the contact spring (Fig. 1) closing the contacts.

A light drag brake B bears on the brake drum section BD of shaft SH. This light drag is constantly present and functions to prevent drift of the tap changer while idle. A slight adjustment of this drag may sometimes be used to improve accuracy of positioning as described in later sections of this leaflet.

Fig. 4 shows the operation of guides G to limit the travel of lever L. When stopped by plugging, the motor may reverse for part of a turn causing the lever to swing in the opposite direction. These guides prevent this back swing from causing hunting of the motor.

### INSTALLATION AND ADJUSTMENT

To install the switch on a tap-changer operating mechanism, follow these steps:

Apply a coat of red gasket cement to the back of the stationary assembly and to the face of its upright support.

Bolt the stationary assembly loosely to the upright support. Slip the rotating assembly carefully into place, drive it onto the motor shaft with the key in place, and tighten the set screws. Before fully tightening the bolts holding the stationary assembly, it must be accurately positioned so the lever travel is correct as shown by Fig. 4. This is determined as follows:

Rotate shaft by hand in each direction. Note the point at which the lever just passes the corner of the guide and begins to move toward closing the contacts. From this point until the stop on the top of the nut engages the notch on the spool end piece should require not less than  $\frac{1}{8}$  nor more than  $\frac{1}{4}$  turn ( $45^\circ$  to  $90^\circ$  rotation) of the spool. Adjust the position of the stationary assembly to meet this condition for both directions of rotation. After tightening the bolts, re-check this adjustment.

Care must be taken to see that the bolts and set screws are fully tightened. The dieter nuts furnished with the bolts

are to be drawn down tightly on top of the regular nuts.

**DO NOT MOVE GUIDES G, AS THEY ARE CORRECTLY ADJUSTED AT THE FACTORY.**

Next apply normal voltage to the control circuit and operate the tap changer over its entire range, stopping on each position and noting the position the roller on cam 120 stops relative to the center of the cam lobe. On an average, the roller should stop on the center of the cam lobe or within  $\frac{1}{4}$  inch before reaching the center of the lobe. Due to certain characteristics of the control circuit, there may be slight deviations from the above limits. However, the roller should always stop within the limits of  $\frac{3}{8}$  inch before, to  $\frac{1}{4}$  inch past, the center of the cam lobe.

If the tap changer consistently stops short or long of the limits given above, the necessary adjustment may be made by changing the pressure of the drag brake. Any such adjustment should be slight, since an excessive drag would tend to overload the tap changer motor with resulting damage to its winding or lockout of the thermoguard. If the switch still fails to stop the tap changer as specified, refer to the procedure described under "Correction of Trouble".

Fig. 5 shows the plugging switch mounted on a standard UR tap changer operating mechanism.

### MAINTENANCE

At each regular periodic inspection of the tap changer, the following maintenance operations should be performed on the plugging switch:

(a) Place a drop or two of lubricating oil on the friction faces of the two oilite friction discs (O - Figs. 2 and 3). Use a high quality mineral oil. Grade SAE-10 is recommended.

(b) Inspect the contacts (XL and XR) for burning and for the condition of the contact surfaces. If necessary, dress the contact surfaces using a very fine file. Style No. 1002110 is recommended.

(c) Check contact spring over-travel. The operating lever should move the

# Plugging Switch for Type UR Tap Changer—Continued

## INSTRUCTIONS—Continued

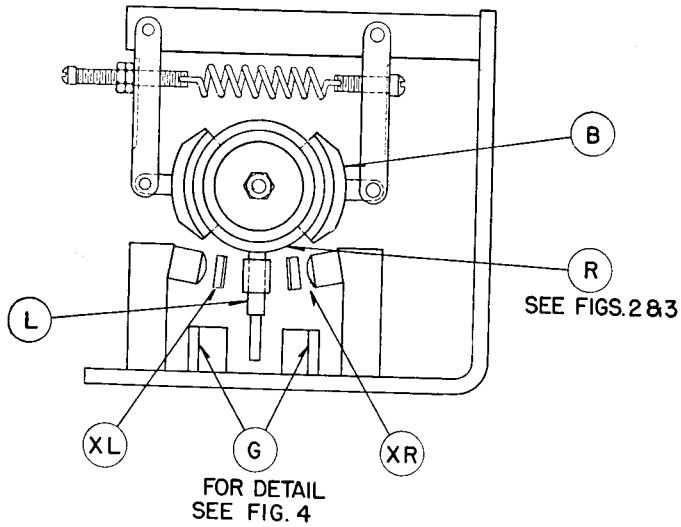

FIG. 1—COMPLETE PLUGGING SWITCH  
END VIEW

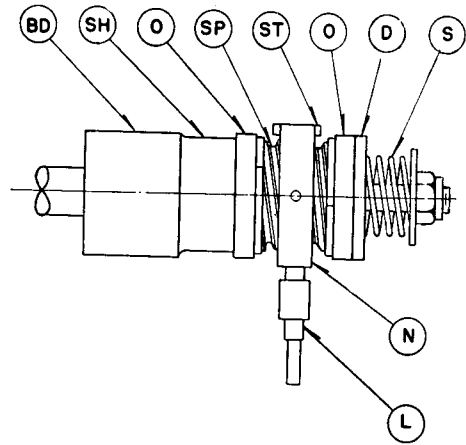

FIG. 2—ROTATING ASSEMBLY

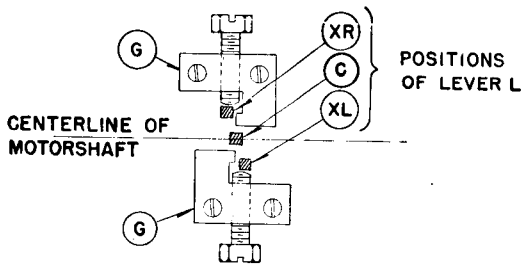

FIG. 3—ROTATING ASSEMBLY VERTICAL  
SECTION OF FIG. 2

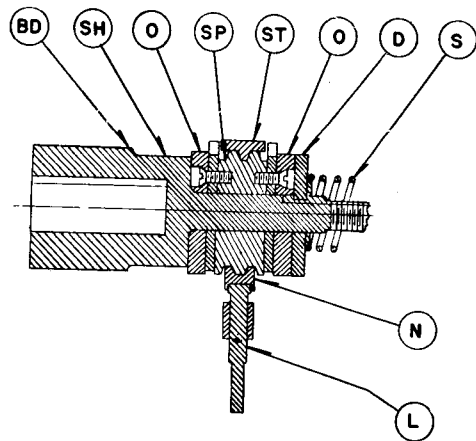

FIG. 4—DETAIL OF GUIDES AND LEVER TRAVEL  
TOP VIEW OF BASE PLATE

## Plugging Switch for Type UR Tap Changer—Continued

### INSTRUCTIONS—Continued

contact leaf spring  $1/32$  inch after the contact closes before the lever strikes the stop screw in the guide. If necessary, adjust the stop screw to obtain this over-travel.

(d) Run the tap changer over its entire range in both directions, stopping on each position, noting on each position the point at which the roller on cam 120 stops. Observe the limits and corrective procedure described in the last two paragraphs of the section entitled "Installation and Adjustment" above.

**Note:** When checking the results of any adjustment affecting the accuracy of positioning, be sure to run the tap changer over its entire range in both directions, noting the accuracy on each

position. Minor variations between positions may be expected within the limits given.

### CORRECTION OF TROUBLES

If the tap changer fails to stop on position, or if it stops with the roller on cam 120 outside the position limits previously given, the following procedure is suggested:

1. Are the leads to the switch connected correctly? If leads XL and XR are reversed, the tap changer will run to the limit position and lock out.

2. Are the back contacts on the motor control relay clean and making good contact?

3. Does the motor control relay drop out sharply when de-energized? If it is sluggish dropping out, it will delay plugging the motor and allow it to run beyond position.

4. Is voltage too low? If adjusted to stop within position limits with normal voltage applied to the control circuit, the switch should stop the changer before roller on the 120 cam passes the center of the cam by  $1/4$  inch with 80% normal voltage applied.

5. Is compression spring (S in Fig. 2) exerting sufficient pressure? The friction drive should be firm enough so the switch will act positively when the shaft is rotated by hand.

6. Are switch contact leaf springs deformed? These springs should open the contacts sharply when pressure on the lever is released. Sluggish action of these springs will cause the motor to travel too far in reverse direction after plugging and stop the tap changer short of position.

### RENEWAL PARTS

No attempt should be made to repair the switch in case of damage. It should be returned to the factory for repair, or a new switch ordered as a replacement.

Contacts may safely be replaced by the customer, but excessive contact burning indicates faulty operation of the switch or of the tap changer mechanism. The cause of the faulty operation should be detected and corrected lest more serious damage occur.

Replacement contacts or a new switch if required should be ordered from the nearest Westinghouse Electric & Manufacturing Company office or Sharon, Pa. Works, giving serial or stock order number of regulator or transformer as will be found on its diagram instruction plate.

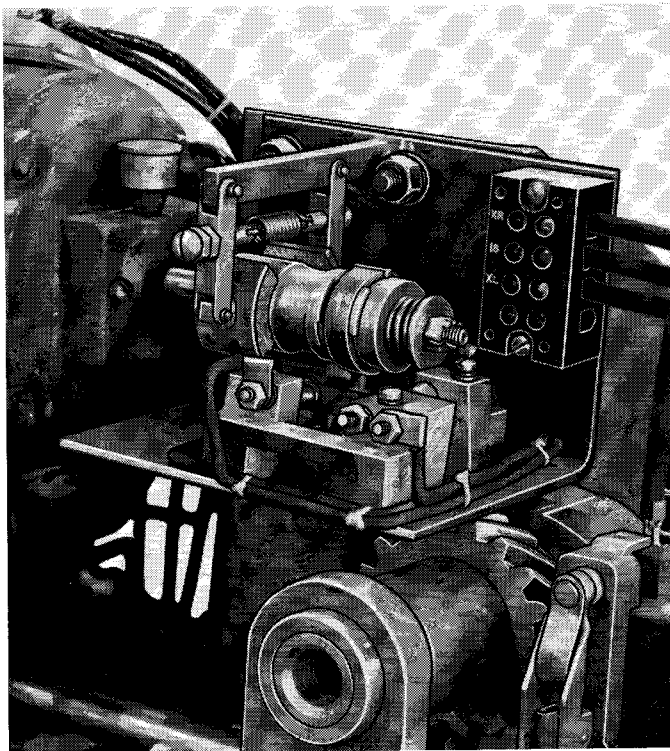

FIG. 5—PLUGGING SWITCH MOUNTED ON A STANDARD UR TAP CHANGER OPERATING MECHANISM

Westinghouse Electric & Manufacturing Company  
Sharon, Pa.