

Westinghouse

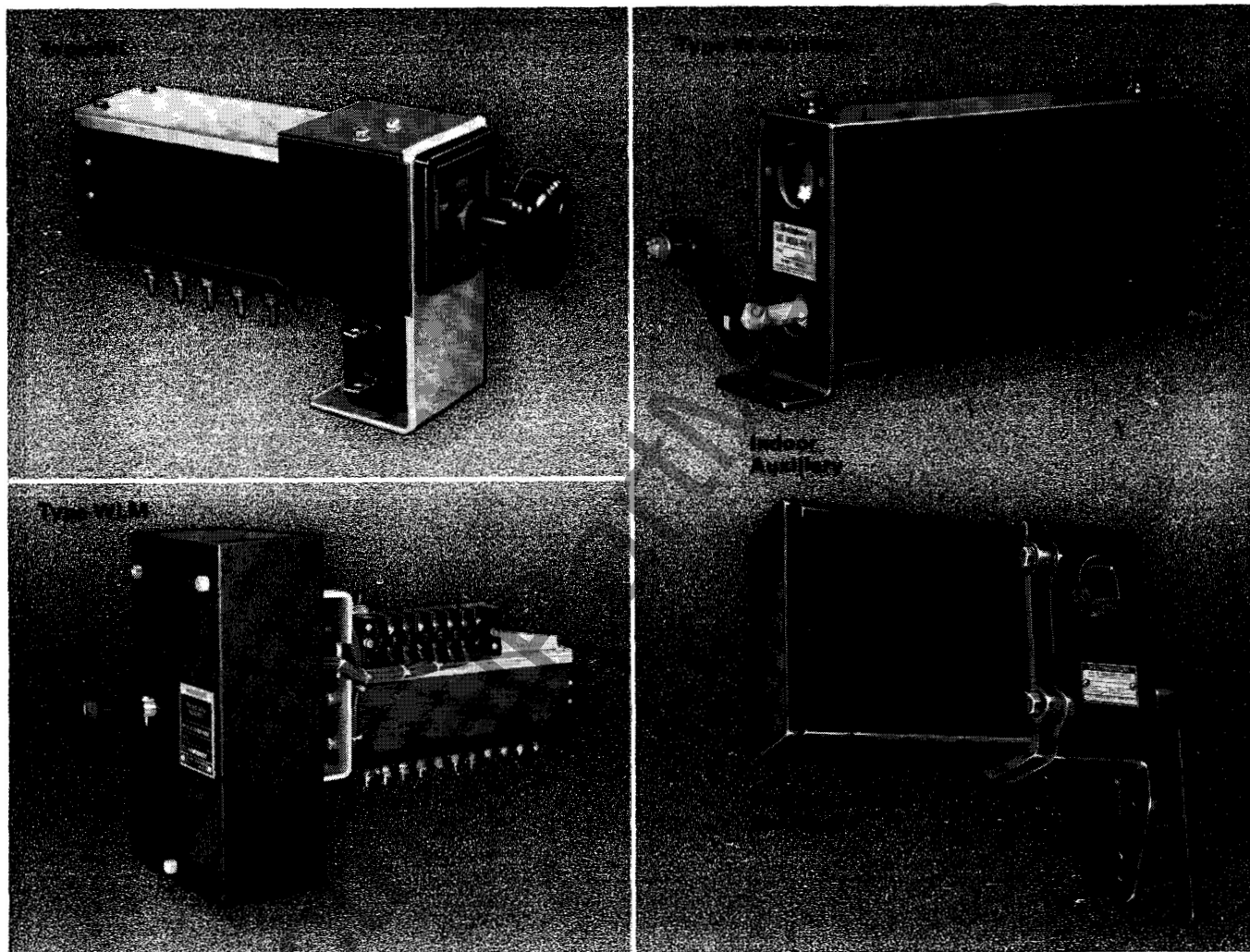

Switches: Types WL, WLM and W Auxiliary

Circuit Breaker Tripping – Control,
600 Volts, 20 Amperes
Continuous Capacity



Application

Type WL

Type WL control switches are solenoid tripped, hand reset, and are applicable where it is desired that a number of operations be performed simultaneously. For example, they can be used to provide simultaneous tripping of several breakers as may be required in differential protection or trip the main circuit breaker of a system in conjunction with other associated auxiliary breakers.

Type WLM

The WLM control switch is similar to the type WL except that in addition to being hand reset, it is provided with a motor reset mechanism thus permitting both remote tripping and resetting.

Type W Auxiliary

The type W auxiliary switch is applicable to circuit breaker operating mechanisms or other apparatus requiring auxiliary switches operable through linkages. They are used to give a signal or alarm as to the action of a mechanical device. The switches may also be used in relay and interlocking circuits. They are available with indoor and weatherproof housings.

May, 1968

Supersedes DB 37-250 dated December, 1962, and
supplement, page .01, dated May 22, 1963
E. D. C/1977/DB

Westinghouse



Type WL Switch

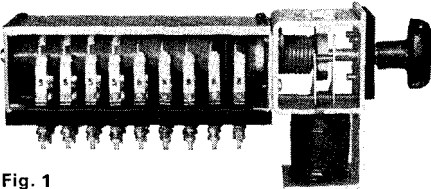

Fig. 1

The type WL switch, incorporating the parts and operating principle of the type W instrument and control switch, is a spring-operated switch with a shunt-trip arrangement. The switch can be provided with any desired arrangement of make and break contacts up to 10; however, by gearing switches, any desired combination or number of circuits up to 30 can be supplied on special order.

The type WL switch is provided with a trip coil as standard for ac voltages of 110, 220 and 440 or dc voltages of 24, 48, 125 and 250, and may be used on static or nonstatic control systems. For all ac voltages and for dc voltages up to 125 volts, only one coil cutoff contact is used (Fig. 3). For 250 volts dc application, two coil cutoff contacts, connected in series are used (Fig. 4). Diode-resistor assembly or capacitor is not included as standard.

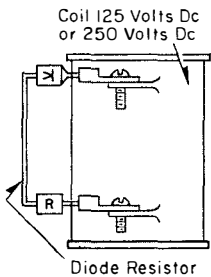

Fig. 2

As an optional feature, a diode-resistor assembly can be added across the coil ter-

minals (Fig. 2) for 125 and 250 volt dc application to prevent excessive arcing and so prolong coil cutoff contact life. A Zener self-protecting diode is used in the assembly. The addition of the diode-resistor will not preclude the use of the WL switch in a solid state system. When applied to 250 volt dc system, two coil cutoff contacts in series are recommended.

In place of the diode-resistor option, there can be supplied a capacitor in the coil circuit to reduce arcing (Fig. 5). This arrangement requires only one coil cutoff contact for all control voltages. Where such a capacitor is used, the switch must not be used on a system incorporating solid state components.

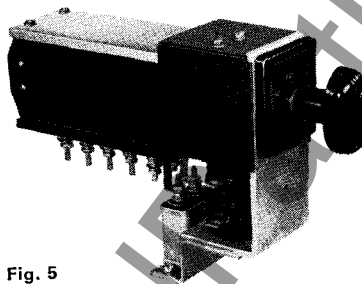

Fig. 5

Two operating arrangements are available: (1) nonhandle trip in which the switch can be tripped only by means of energizing the shunt trip coil, and (2) handle trip in which the switch can be tripped by rotating the handle at the front of the switch or by energizing the shunt trip coil.

Position of the operating handle provides a visible indication of the last operation of the switch. A target indicator can be supplied on request.

Performance

The contacts are normally held in "reset" or "open" position against the force of a torsional spring by a positive latch. A high angle of rake and one latch spring are used to insure a positive latch at all times so that the contacts cannot be bumped, jarred or vibrated to the release position.

The plunger of the solenoid is independent of the latch and operates with a hammer-like blow against the latch to release the rotor mechanism. The latch itself is a two-piece roller type, pivoted at one end. All latching surfaces are made of hardened steel, with a durable finish for long life.

A strong coil insures positive tripping. The torsional spring provides the force for the trip action of the switch. Because of its strength, a high speed of operation is obtained, providing a higher interrupting capacity than is usual with standard auxiliary switches.

Interrupting Capacity

The following values are for inductive circuits:

Volts	Interrupting Capacity	
	Dc Amperes	Ac Amperes
60	30	40
125	30	40
250	10	20
600	4	10

Auxiliary Switches

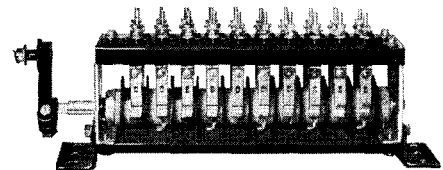

Fig. 6: Indoor Type

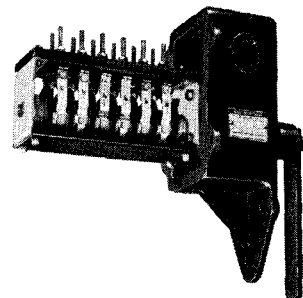
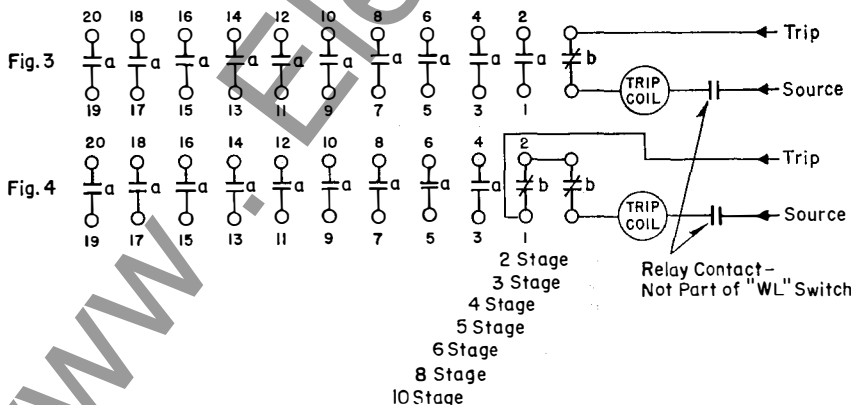

Fig. 7: Weatherproof Type, Cover Removed

Typical Wiring Schematic using one coil cutoff contact (Fig. 3) and for 250 volts using two coil cutoff contacts wired in series (Fig. 4)



- 2 Stage
- 3 Stage
- 4 Stage
- 5 Stage
- 6 Stage
- 8 Stage
- 10 Stage

Switches: Types WL, WLM and W Auxiliary

Circuit Breaker Tripping - Control,
600 Volts, 20 Amperes
Continuous Capacity

Type WLM Switch

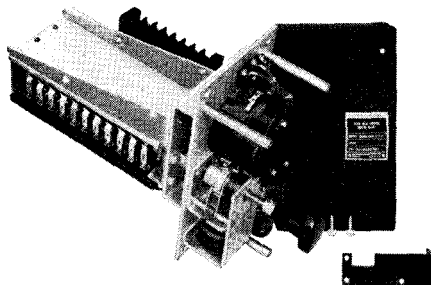

Fig. 8

The type WLM switch is a spring-operated switch with shunt trip and motor reset mechanisms for either 120 or 220 volt circuits. The basic switch, shunt trip mechanism and roller latch mechanism are the same as those on the type WL switch.

The motor mechanism utilizes type ADS motor as used on Westinghouse circuit breakers and network protectors. This motor, operating through a gear train, causes a cam assembly to rotate, and during part of the rotation makes mechanical contact with a reset lever securely fastened to the switch shaft. The cam rotates this lever to the position of reset. Once the lever resets the mechanism, it is latched and the cam may continue its rotation without any effect on the lever.

The motor circuit is equipped with a cutoff switch, which opens during part of cam rotation causing the motor to stop until the

Wiring Schematic

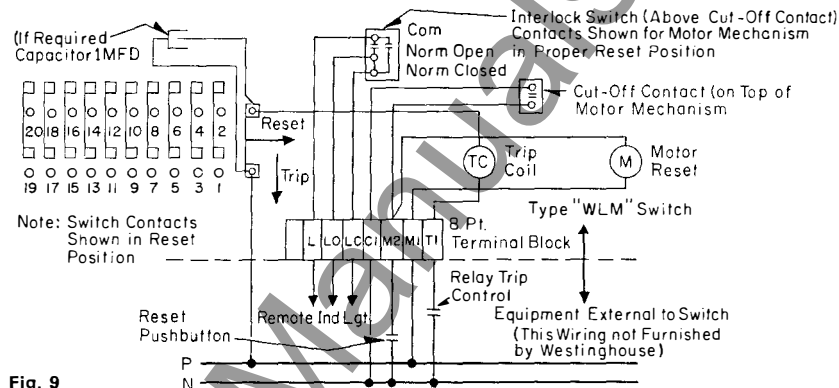

Fig. 9

reset button (supplied by purchaser) is released. The reset pushbutton should be of the momentary contact type. If the reset button is held down, maintaining a closed circuit, the motor will continue to operate. This will not cause any malfunction of the motor mechanism. It only means it runs excessively until the reset contact is opened, which then allows the cutoff switch to stop the motor automatically. The motor mechanism stops so that the cam assembly will not interfere with the reset lever in the tripping operation of the switch.

In addition, the WLM switch is equipped with a double throw microswitch to provide auxiliary make and break contacts for indicating when motor has reset and stopped

cam properly for electric tripping. Indicating lights can be connected to circuits for remote signaling. All wiring for the trip coil, motor and microswitch is connected to a terminal block mounted on the top of the switch cover behind the panel, thereby simplifying installation wiring for the customer.

The type WLM switch is designed for front panel mounting, requiring a cutout in the panel for insertion of switch body. The trip mechanism and motor assembly are on the front of panel. All wiring connections are made behind the panel. The mechanism is enclosed in a neat, heavy gauge sheet metal cover with a black crinkle finish. Cover is held secure by three thumb screws.

Auxiliary Switches Operation

The rotor turns to two positions 90 degrees apart. The rotor segment makes contact with its pair of stationary fingers in one or the other 90-degree position. Any individual segment can be rotated 90 degrees to change from a "make" to a "break" contact or vice versa. Special segments can be supplied for special switching arrangements.

Indoor Auxiliary Switch Construction

The switch is made in two forms, with and without terminal covers. The switch equipped with a Micarta® cover has provision for bringing out terminal leads from either end of the switch through holes provided in the end brackets. A coverplate is supplied for the hole not in use.

The switch without cover is used on applications where the apparatus is otherwise housed, for example, with the operating

mechanism on outdoor oil circuit breakers. The operating lever of both types of switches clamps to the squared end of the rotor shaft. Provision is made for changing the length of the operating lever so as to adapt the switch to an operating rod travel of from one to three inches. The angular travel of the rotor is always 90 degrees.

Where wires are to be carried in conduit, the auxiliary switches are arranged to accommodate a special nut with 1¼-inch pipe threads which can be bolted to the switch bracket. This nut (Style No. 762198), with mounting bolts is not included in the switch style number, but will be furnished when ordered with the switch without additional charge.

Weatherproof Auxiliary Switch Construction

Weatherproof auxiliary switches can be furnished in 2, 4, 6 or 10-stage types, and a made of standard indoor switch parts mount

ed on a cast brass base to which the cover is bolted. Switches with eight stages or an odd number of stages are available on special order.

The base contains holes for ¾-inch mounting bolts. Holes tapped for conduit connection are provided on two sides and the top, two of which are fitted with pipe plugs. These holes are for 1-inch conduit on the 2 and 4-stage switches, 1½-inch conduit on the 6-stage switch, and 1½-inch conduit on the 10-stage switch.

A substantial cover, with a cast alloy flange, is provided to enclose the switch. This cover contains an inner lining of insulating material. All joints are fitted with gaskets to assure weatherproof construction.

Switches: Types WL, WLM and W Auxiliary

Circuit Breaker Tripping – Control,
600 Volts, 20 Amperes
Continuous Capacity

Dimensions (In Inches)

Type WL Switch

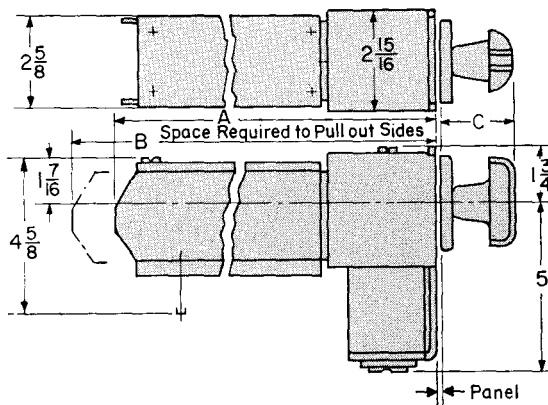

Handle Types

Modern Oval

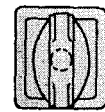

Fig. 1

Heavy Duty Oval

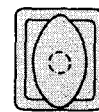
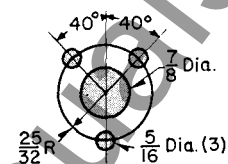

Fig. 2

Figure Number	Dimension C
1	2 1/8
2	3 1/8

Drilling Plan



Number of Stages ^①	Dimensions		Coils
	A	B	
2	7 1/8	12 1/8	110-volt, 60-cycle
3	8 3/32	14 3/8	220-volt, 60-cycle
4	9 7/8	16 1/8	24-volt, dc
5	9 3/32	17 7/8	48-volt, dc
6	10 1/8	19 1/8	125-volt, dc
8	12 1/2	22 1/8	250-volt, dc
10	14 3/8	26 1/8

① See wiring diagram, page 2.

Type WLM Switch

Stages	Dimensions			
	Single Units		Geared Units	
	A	B	A	B
1-2	4 1/32	8 1/16	5 3/32	10 1/16
3	5 1/4	10 3/8	5 15/16	11 1/8
4	6 3/32	12 1/16	6 29/32	13 3/16
5	6 1/16	13 3/8	7 1/8	15 1/8
6	7 29/32	15 1/16	8 15/32	16 13/16
7-8	9 15/32	18 1/16	10 3/32	20 1/16
9-10	11 3/32	23 3/32	11 27/32	23 1/32

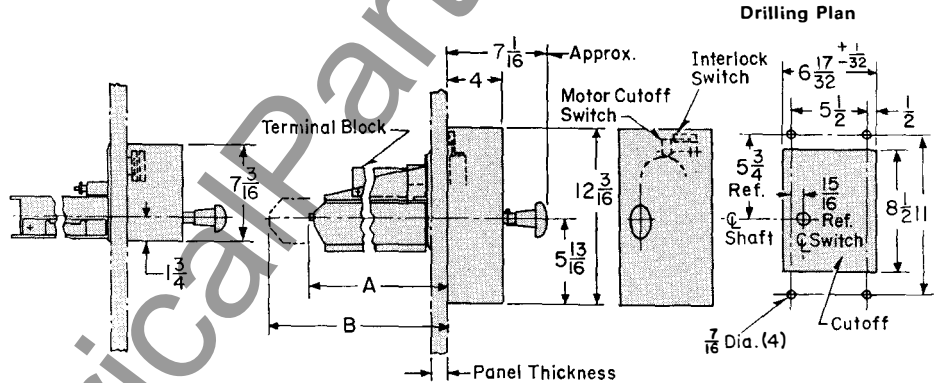

Drilling Plan

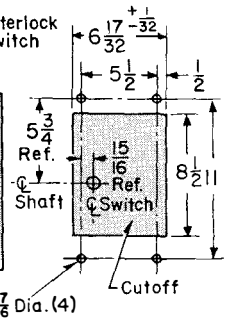

Indoor Auxiliary Switch

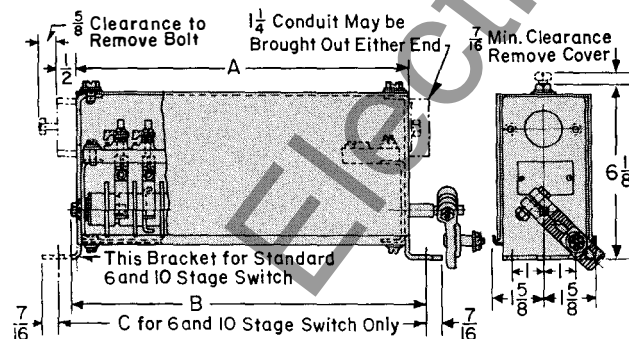

Description	Stages	Contacts ^③		Dimensions			Style Numbers	
		"Make" ("a")	"Break" ("b")	A	B	C	With Cover	Without Cover
	2	1	1	3 3/8	4 1/32	676 957	591 816
	4	2	2	5 1/8	6 3/32	676 960	591 819
	6	3	3	7 1/8	7 29/32	8 1/8	676 963	591 822
	10	5	5	10 1/2	11 3/32	11 1/2	676 966	591 825

Weatherproof Auxiliary Switch

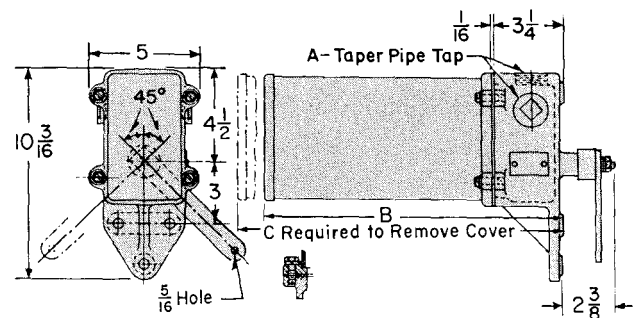

Description	Stages	Contacts ^③		Dimensions			Style Numbers
		"Make" ("a")	"Break" ("b")	A	B	C	
	2	1	1	1-11 1/2	7 1/8	11 1/4	599 938
	4	2	2	1-11 1/2	9	14 1/2	599 939
	6	3	3	1 1/2-11 1/2	10 1/8	17 1/2	599 940
	10	5	5	1 1/2-11 1/2	14 1/8	24 1/2	599 941

③ The letters "a" and "b" designate "make" and "break" as shown in the NEMA handbook on switching equipment.