

ENCLOSED "BUILDING-TYPE" DISTRIBUTION SWITCHBOARDS are specifically designed for the control of low voltage distribution circuits (600 volts and below) in offices and other commercial types of buildings, where Westinghouse Type AB Nofuze "De-ion" circuit breakers are suitable for ratings up to and including 600 amperes. For ratings above 600 amperes,

Westinghouse air circuit breakers of the fixed DA type are available. For circuits 600 amperes and below where the characteristics of the AB breaker do not meet the job application requirements, fixed type DB air circuit breakers are available.

NOTE—In industrial plants and other applications where complete access to any individual breaker for quick inspection, maintenance, repair or replacements is important to continuity of service, the use of Westinghouse Low-Voltage Metal-Enclosed switchgear with drawout air circuit breakers is recommended.

WESTINGHOUSE FEATURES

1

STANDARDIZED FOR LOWER INSTALLED COSTS—Westinghouse standardized design eliminates special design and engineering costs; yet, it is "custom-built" in that it meets specific application requirements.

3

SAFETY ASSURED—Totally enclosed construction means protection against accidental contact with live parts.

2

QUICKLY PLACED IN SERVICE—Factory-assembled, factory-wired and factory-tested, the switchboard is ready for installation and connection upon arrival at destination.

4

MODERN STREAMLINED APPEARANCE—"Building-type" distribution switchboards not only harmonize in appearance with modern equipment, but their construction is modern throughout.

NEW INFORMATION

E42-5H; D63-5D; C26-5C; C20-5, DAK
Classified File

EFFECTIVE JANUARY, 1950

1 MODERN APPEARANCE

"Building-type" switchboards are fabricated from sheet steel manufactured by the stretcher-leveled process. This process results in an absolutely level panel surface which greatly enhances its final appearance. All front covers are flanged—No flat sheet steel butt joints are used. Previous to applying grey finish coats, all structural members and panels are rust proofed, a process which provides a secure anchor for final enamel coat, minimizes corrosion, improves appearance and assures a lasting finish.

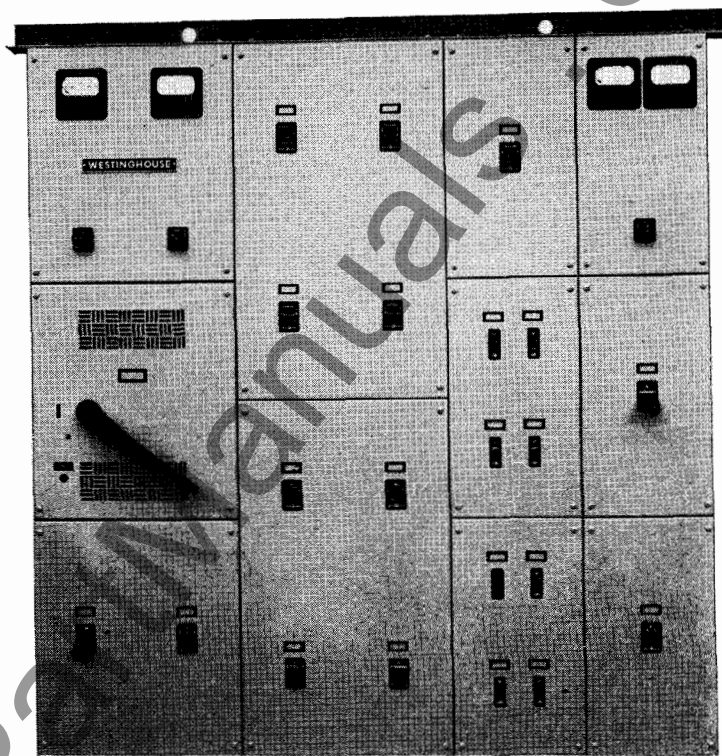

2 LOWER INSTALLED COST

This type of switchboard permits any number of special assemblies without extra engineering cost through the use of standard structural parts, standard circuit breakers and associated equipment. In addition to lower installed cost, this switchboard design assures matching of future additions at either end of the structure or re-arrangement of an existing switchboard without factory assistance.

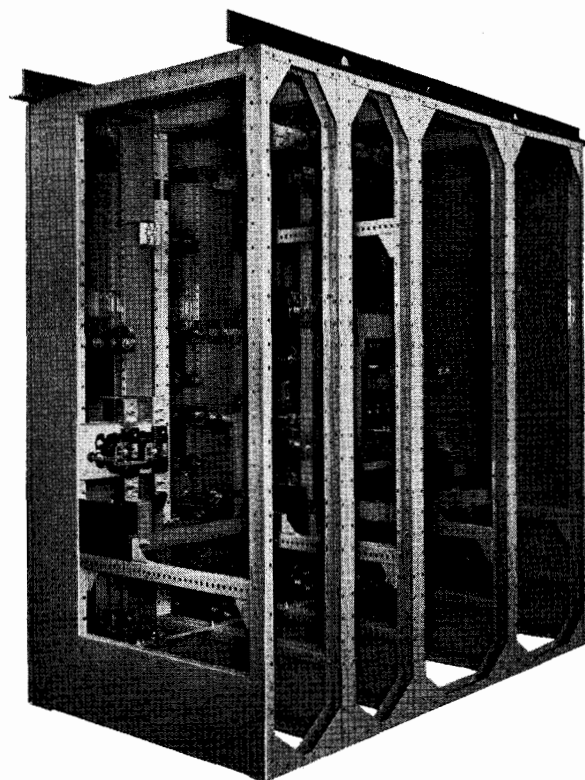

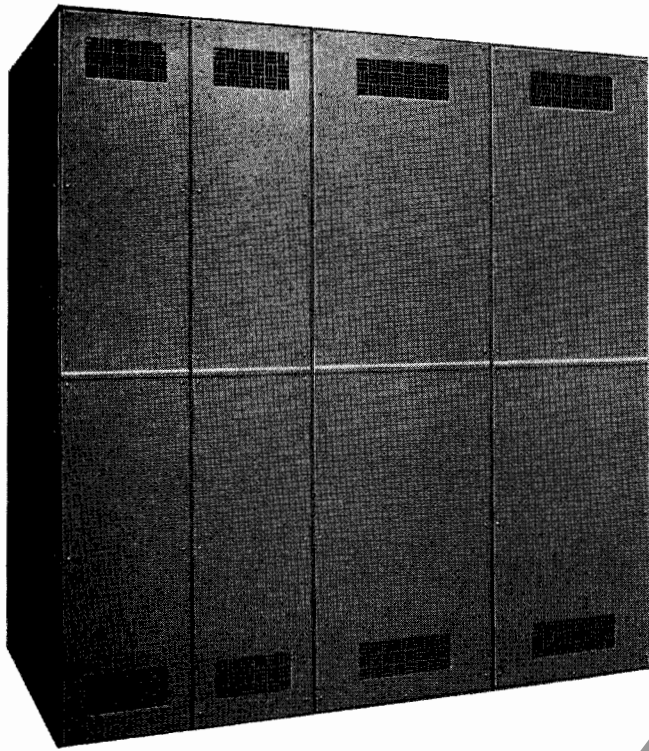

3 COMPLETELY METAL ENCLOSED, SELF SUPPORTING

"Building-type" switchboards consist of a completely metal enclosed, self-supporting metal structure containing one or more fixed air circuit breakers with associated bus bars, instrument transformers and instruments where required. Types DB and DA breakers when used are enclosed in individual cells—The molded case of the Type AB breaker acts as an individual cell. Instruments are semi-flush mounting type.

Rear View of Switchboard
Shown At Left.

4 QUICKLY PLACED IN SERVICE

These switchboards are factory-assembled, factory-wired and factory-tested, and are shipped as a single unit (if handling facilities at destination permit) ready for placement on a channel iron foundation which can be installed in advance. All that is required is fastening switchboard to base and completing main cable and circuit connections. Each switchboard is shipped with temporary steel angle irons bolted on top for handling with a crane.

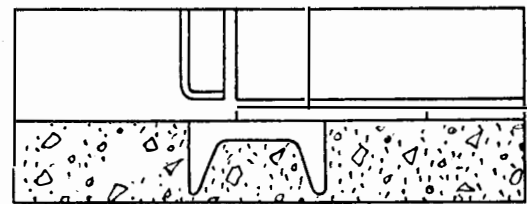
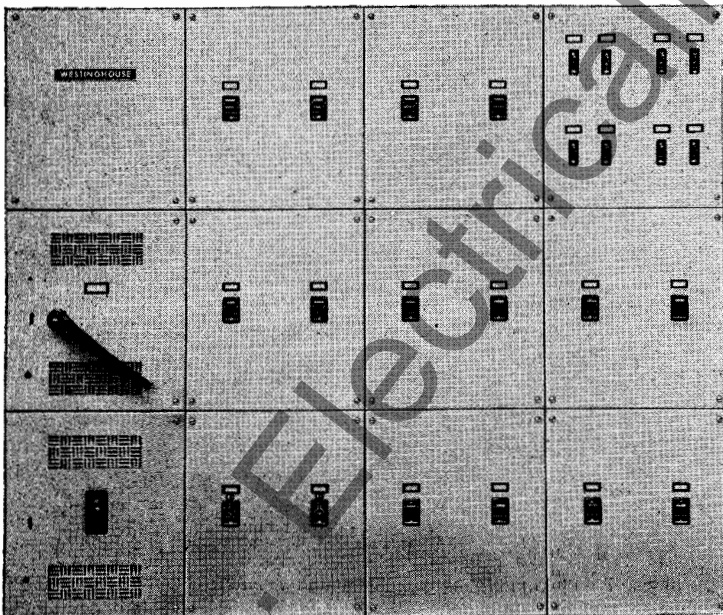

Front Channel And Corner Of Housing.

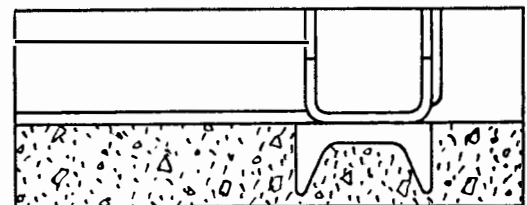

Rear Channel And Corner Of Housing.

THE STEEL CHANNELS (supplied by the purchaser) should be imbedded in a concrete floor with the top surfaces of the channels flush with the finished floor.

UNIVERSAL FRAMES

Standardized "Building-type" switchboards are designed to meet various combinations of circuit requirements and circuit breaker arrangements. This design makes it possible to locate circuit breakers, bus-bars, instrument transformers, etc., as dictated by circuit and circuit breaker arrangements without sacrifice of flexibility. This has been accomplished through use of standardized basic parts from which all "Building-type" switchboards are fabricated. These parts are:

- 1 Standardized Circuit Breaker Cell Structures
- 2 Rear Frames
- 3 Bottom Members
- 4 Top Member
- 5 Bus-Bar Support Members including Insulating Blocks
- 6 Mounting for DA-50 Circuit Breaker

FLEXIBLE DESIGN—Universal frame structures provide much greater flexibility and adaptability for present and future use than equivalent all-welded construction. All members of the frame structure are cut to a standard pattern but the key to the flexibility of this switchboard is the square hole punchings at regular intervals, permitting the use of standard $\frac{3}{8}$ " carriage bolts for all fastenings. This results in a flexible arrangement whereby circuit breakers, bus-bars, instrument transformers, etc., can be installed to conform to dimensions of all types of circuit breakers, etc., used. They facilitate changes in the field without factory assistance.

THE CELL STRUCTURE (1) forms a vertical steel barrier between each complete panel group. It is open at the back to permit connecting bus-bars to circuit breaker studs.

THE REAR FRAME is of welded steel construction and adequately braced with steel corner plates welded in position.

HEIGHT—Switchboards are built in two overall heights—75 $\frac{3}{8}$ " and 90 $\frac{3}{8}$ " including bottom mounting plate and top cover. Mounting channel not included.



BUS BAR ARRANGEMENT

Standard bus supports permit mounting 3 phase buses with one, two, or three bars per phase, in widths up to 6-inches, thus giving a maximum current carrying capacity of 3800 amperes. The mechanical strength is adequate for short circuit currents up to 50,000 amperes, average 3 phase r.m.s. current.

The bus support parts are made up of Micarta and are arranged for mounting on the steel bus support member, one of the standard universal frame parts. As shown in Figure 1, the bus support can be located against the back of the breaker cell structure with the outer end against an angle bracket. An angle bracket can be used at each end of the support assembly if the bus is located back from the breaker cell structure. The insulating members are made up of five parts, one being a quarter-inch thick Micarta channel which straddles the steel support member, and the other four are Micarta blocks. These blocks are deeply tapped on two edges for $\frac{3}{8}$ inch bolts which enter from the bottom through the steel and Micarta channel.

Figure 1 shows the support arranged for one bar per phase. Figure 2 shows the block nearest the breaker unit and the second block from it turned upright. The horizontal dimension of the block is shorter with this mounting, and permits the addition of one more bar per phase. The original three bars were on 4-inch centers and their position remains unchanged, so that with a bus having two bars per phase, the actual centers of the conductors are no longer equally spaced. Figure 3 shows all of the blocks turned upright, with three bus bars used in each phase conductor. In this case the center bar of each group is in the same position as when a single bar was used and the busses are again on 4-inch centers.

The universal frame construction makes it possible to locate the bus supports in any desired position, and re-arrangements of busses can be made easily in the field if changes in loads make this necessary.

FRONT PANEL AND CIRCUIT BREAKER ARRANGEMENT

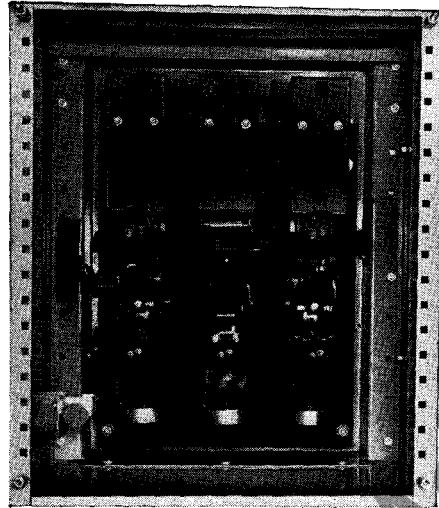
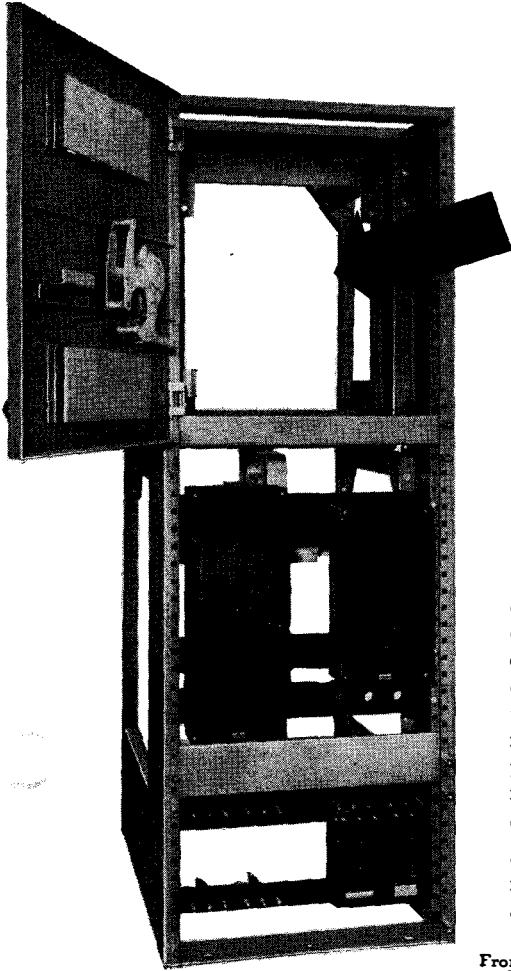

Type DA-50 Circuit Breaker As It Would Appear in Switchboard At Left.

CIRCUIT BREAKER MOUNTING—Type AB "De-ion" circuit breakers are fixed mounted within the cell structure on Micarta cross members. These cross members are drilled to accommodate circuit breaker studs. By using special insulated tools, Type AB breakers are removable from the front of the switchboard without disturbing adjacent units, or without removing studs, disturbing copper bus or disconnecting load cables. The steel structure used for mounting Types DA and DB circuit breakers are designed to form individual steel cells. Breakers may be removed after first disconnecting bus from breaker studs.

Front View Switchboard Shown At Left with DA-50 Circuit Breaker Removed.

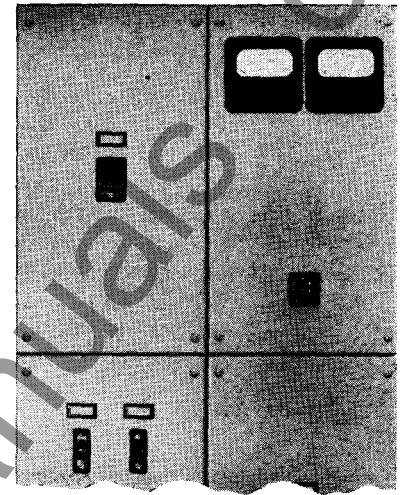

FRONT PANELS—The square punchings also serve for mounting of all front panels. Panels align themselves perfectly and those for AB Breakers are held in place by button-headed machine screws which fit snugly to the panel and conform to the streamlined effect of the entire switchboard.

Panels for Types DA and DB circuit breakers have concealed hinges so that they can be swung open for ready access to the breaker. Refer to pages 8 and 9 for panel dimensions and circuit breaker arrangements.

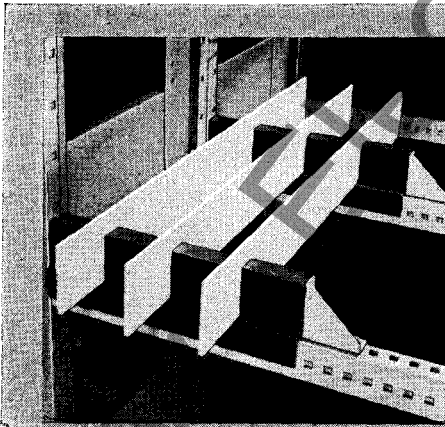

Fig. 1—Three-Phase Bus-Bar Arrangement Using A Single Bus-Bar Per Phase.

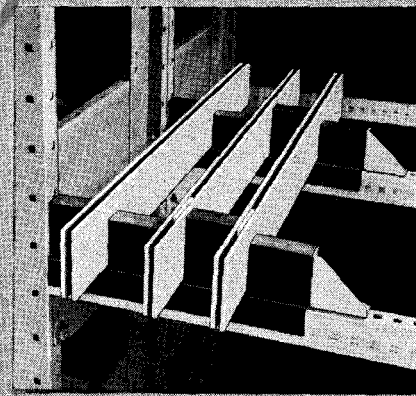

Fig. 2—Three-Phase Bus-Bar Arrangement Using Two Bus-Bars Per Phase.

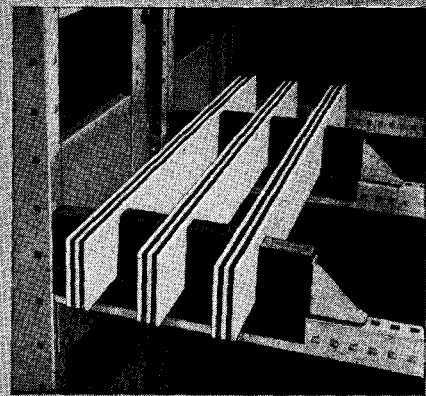

Fig. 3—Three-Phase Bus-Bar Arrangement Using Three Bus-Bars Per Phase.

SELECTION OF CIRCUIT BREAKERS

CIRCUIT BREAKERS should be selected not only on the basis of continuous current rating but must provide adequate interrupting capacity. No over-current protective device (fuse or circuit breaker) should be applied on systems in excess of the manufacturer's published interrupting capacity of the device unless such application is in accordance with recognized engineering practice.

Recognizing that conditions, applications, and requirements vary with each job, the information given on this and the following page makes it possible to select the proper breaker. Two factors influence the selection:

- (a) Continuous current rating required.
- (b) Interrupting capacity requirements of the application.

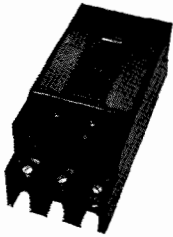

Type AB, "F" Frame Breaker with Non-interchangeable Trip Units.

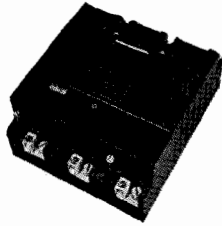

Type AB "G", Frame Breaker with Interchangeable Trip Units.



Type AB "K" Frame Breakers with Interchangeable Trip Units.



Type AB "L" Frame Breaker with Interchangeable Trip Units.

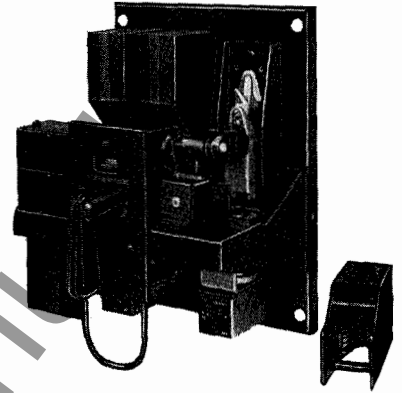

Type DB-15 Breaker with Front Panel Removed.

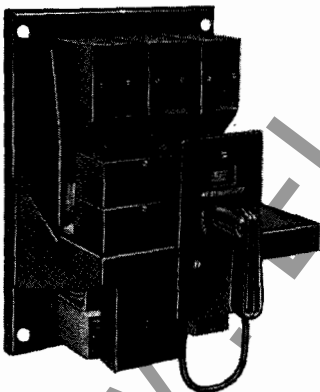

Type DB-25 Breaker.

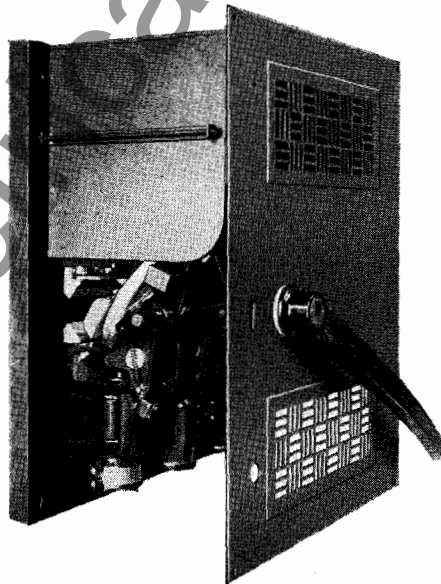

Type DA-50 Manually Operated Breaker, with Front Plate and Breaker Handle in Position.

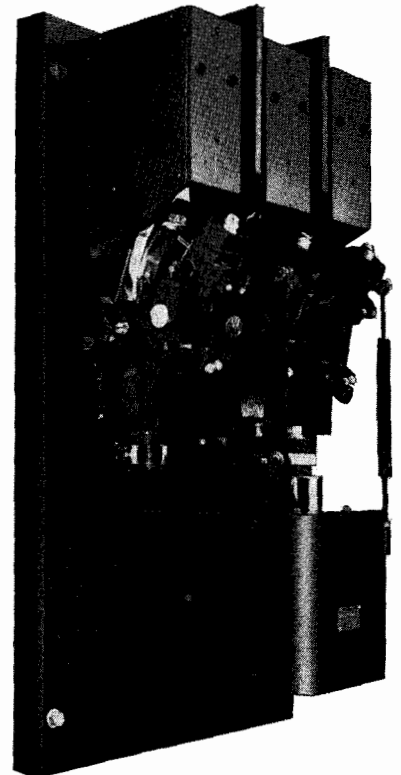

Type DA-75 Electrically Operated Breaker with Cover Removed.

CIRCUIT BREAKER TYPES AND RATINGS

| FRAME AND TYPE OF CIRCUIT BREAKER | MAXIMUM CONTINUOUS RATING AMPERES | AVAILABLE AMPERE RATINGS | AVAILABLE VOLTAGE RATINGS | MAXIMUM A-C INTERRUPTING CAPACITY BASIS NEMA STANDARD | OPERATION |
|-----------------------------------|-----------------------------------|---|---|---|----------------------|
| "F" Frame Type AB | 100‡ | 15,20,30,40,50,70,90,100 | 250 volts a-c, 125/250 v. d-c 600 volts a-c, 250 volts d-c | 5000 A. at 250 v. 15,000 A. at 600 v. | Manual Only |
| †"G" Frame Type AB | 100‡ | 50,70,90,100 | 250 volts a-c, 125/250 v. d-c 600 volts a-c, 250 volts d-c | 15,000 Amperes | Manual Only |
| †"K" Frame Type AB | 225‡ | 70,90,100,125,150,175, 200,225 | 250 volts a-c, 125/250 v. d-c 600 volts a-c, 250 volts d-c | 15,000 Amperes | Manual Only |
| †"L" Frame Type AB | 600‡ | 125,150,175,200,225,250, 275,300,325,350,400,450, 500,550,600 | 250 volts a-c, 125/250 v. d-c 600 volts a-c, 250 volts d-c | 25,000 Amperes | Manual Only |
| Type DB-15 | 225 | 15,20,25,35,50,70,90,100, 125,150,175,200,225 | 600 volts a-c, 250 volts d-c | 15,000 Amperes | Manual or Electrical |
| Type DB-25 | 600 | 35,50,70,90,100,125,150, 175,200,225,250,300,350, 400,500,600 | 600 volts a-c, 250 volts d-c | 25,000 Amperes | Manual or Electrical |
| Type DA-50 | 1600 | 200,225,250,300,350,400, 500,600,800,1000,1200, 1600 | 600 volts a-c, 250 volts d-c | 50,000 Amperes | Manual or Electrical |
| Type DA-75 | 3000 | 2000,3000 | 600 volts a-c, 250 volts d-c | 75,000 Amperes | Electrical Only |
| Type DA-100 | 4000 | 4000 | 600 volts a-c, 250 volts d-c | 100,000 Amperes | Electrical Only |

* Non-interchangeable Trip Units.

† Interchangeable Trip Units.

‡ Continuous ampere rating based on circuit breaker operating in the open in an ambient of 25°C.

AVAILABLE ATTACHMENTS FOR AIR CIRCUIT BREAKERS

| DESCRIPTION | "AB" "F" FRAME | "AB" "G" FRAME | "AB" "K" FRAME | "AB" "L" FRAME | DB15 DB25 | DA50 | DA75 | DA100 |
|---|----------------|----------------|----------------|----------------|-----------|------|------|-------|
| Instantaneous series overload trip for DA and DB breakers | — | — | — | — | ● | ● | ● | ● |
| Inverse time series overload trip for DA and DB breakers | — | — | — | — | ● | ● | ● | — |
| Dual-magnetic series overload trip | — | — | — | — | — | — | — | — |
| Thermal-magnetic series overload trip | ● | ● | ● | ● | — | — | — | — |
| Transformer trip, time delay or instantaneous | — | — | — | — | — | — | — | ● |
| Shunt trip | ● | — | ● | ● | ● | ● | ● | ● |
| Undervoltage trip, instantaneous | — | † | ● | ● | ● | ● | ● | ● |
| Undervoltage trip, time delay | — | — | — | — | ● | ● | ● | ● |
| D.C Reverse Current Trip | — | — | ● | ● | ● | ● | — | — |
| Bell alarm switch for manually operated breakers | ● | ● | ● | ● | ● | ● | — | — |
| Auxiliary Switch | * | * | * | * | ● | ● | ● | ● |

● Available

— Cannot be supplied

† Available on 3-pole breakers only

* Number of auxiliary switches per breaker is limited. Refer to nearest Westinghouse office if more than one per breaker is required.

For further information concerning details and permissible combinations of attachments for individual circuit breakers, consult nearest Westinghouse Office.

LAYOUT INSTRUCTIONS

(Read Carefully)

Switchboards are built in 2 overall heights—75 $\frac{3}{8}$ " and 90 $\frac{3}{8}$ " including bottom mounting plate and cover (not shown in layout views).

All depth dimensions are recommended minimums, but depth of deepest unit determines overall switchboard depth. Where job conditions require shallower depths, consult nearest Westinghouse office.

DA, DB OR AB BREAKERS can be omitted from any section to provide a blank panel section for mounting instruments. The front covers of 30" high AB breaker sections can be divided into 2 individual 15" high sections, one of which may be used as a 15" high instrument panel.

MANUALLY OPERATED DA-50 OR DB BREAKERS may be mounted at the top and/or middle of the same vertical panel with AB breakers provided the latter are mounted below the DA or DB breakers. An electrically operated DA-50 breaker can be substituted for the manually operated DA-50, but a section height of 45" will apply. AB breakers cannot be mounted on the same vertical panel with DA-75 or DA-100 breakers.

A manually operated and an electrically operated DA-50 breaker can be combined on the same vertical panel. DB breakers can be combined on the same vertical panel as DA-50 breakers; however when so combined, the DB breakers will require a section width of 26".

A 26" WIDE BY 30" HIGH SECTION can be utilized for installing a lighting panel with a maximum of 24 single pole Quicklag or E-frame type AB circuit breaker branches and main lugs only.

TYPES DA AND DB CIRCUIT BREAKER PANEL

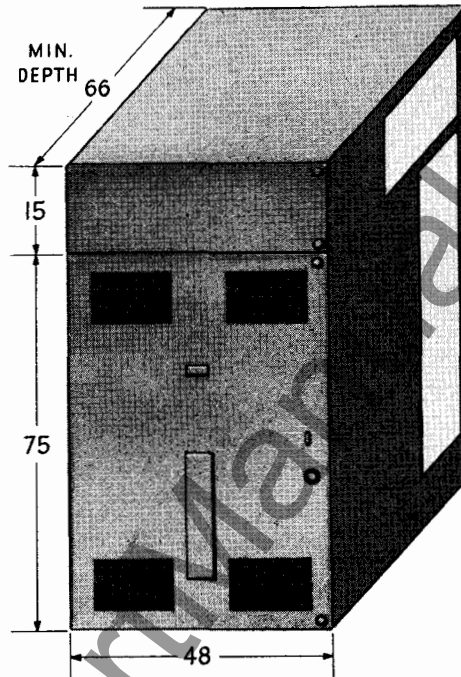

Fig. 1—4000 Ampere DA-100 Electrically Operated Breaker Panel.

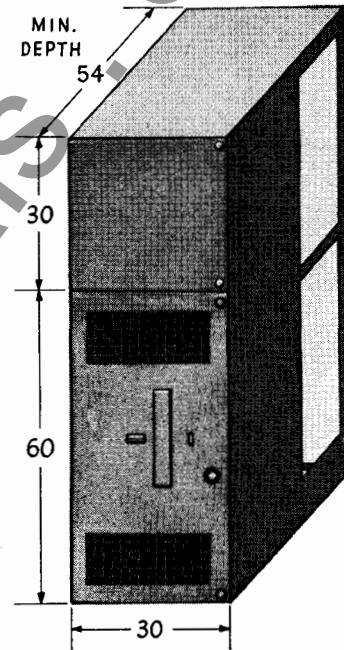

Fig. 2—DA-75 Electrically Operated Breaker Panel.

TYPE AB "DE-ION", F, G, K AND L FRAME BREAKER PANEL ARRANGEMENTS AND Letters at Handle Locations Indicate AB Breaker Frame

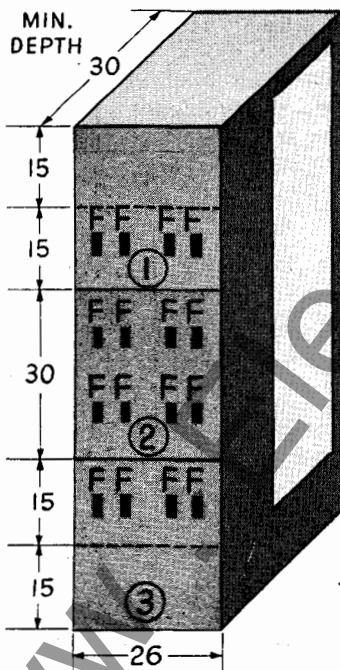

Fig. 7

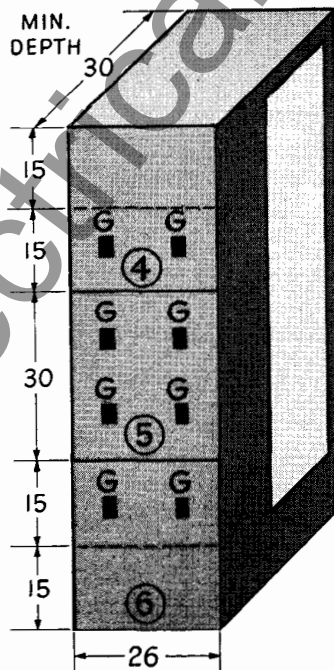

Fig. 8

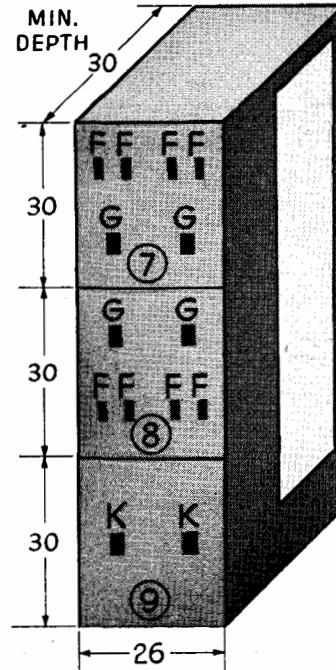

Fig. 9

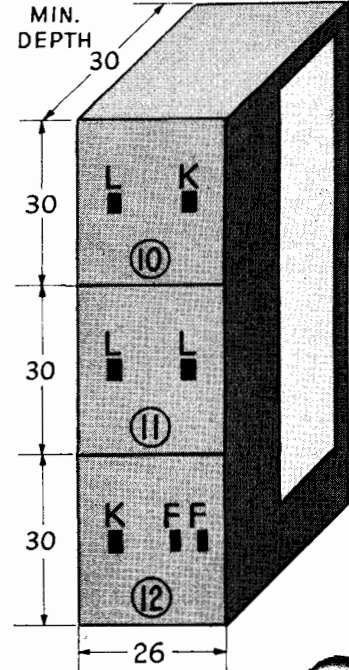

Fig. 10

Numerals in Circles i.e. (1) are for Quick Reference to Various AB Breaker Sections.

ARRANGEMENT AND DIMENSIONS

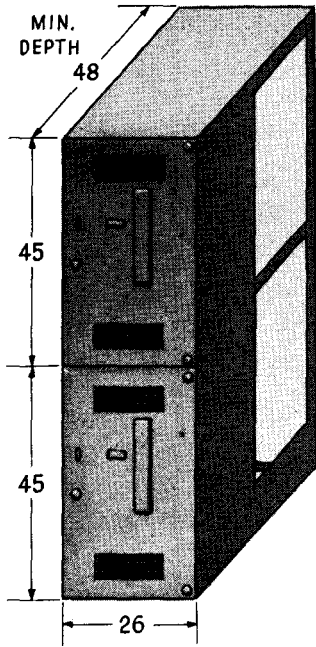

Fig. 3—DA-50 Electrically Operated Breaker Panel.

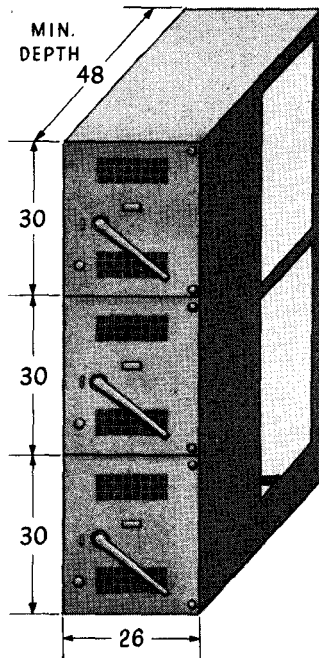

Fig. 4—DA-50 Manually-Operated Breaker Panel.

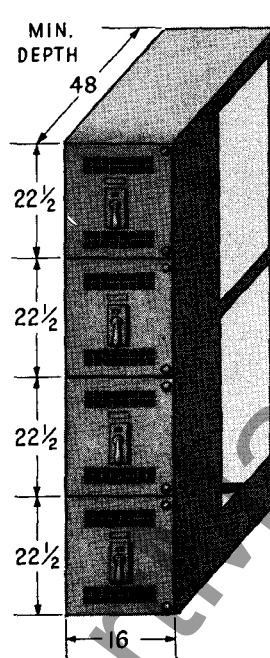

Fig. 5—DB-15 or DB-25 Manually or Electrically Operated Breaker Panel.

BLANK PANEL

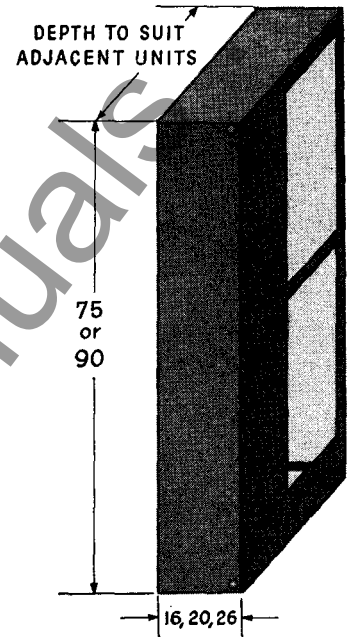

Fig. 6

DIMENSIONS

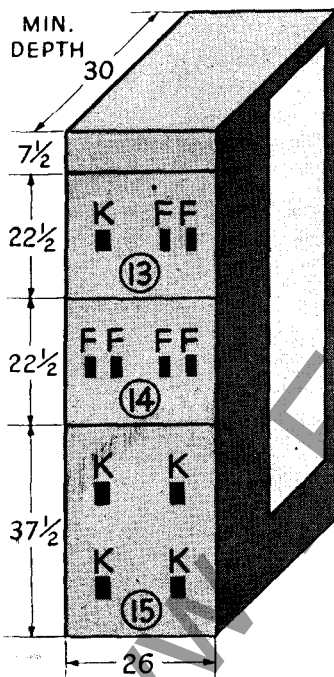

Fig. 11

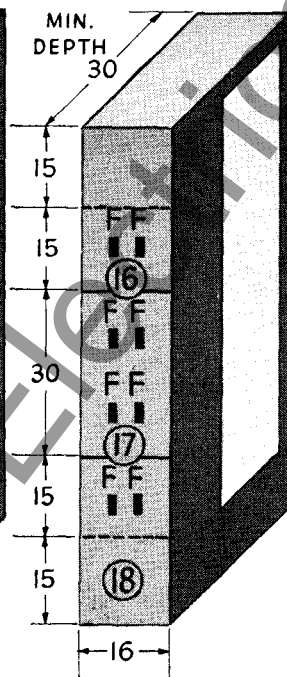

Fig. 12

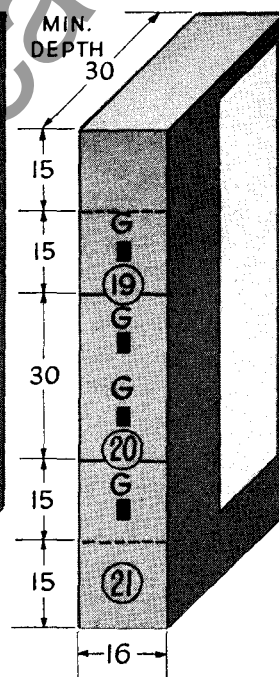

Fig. 13

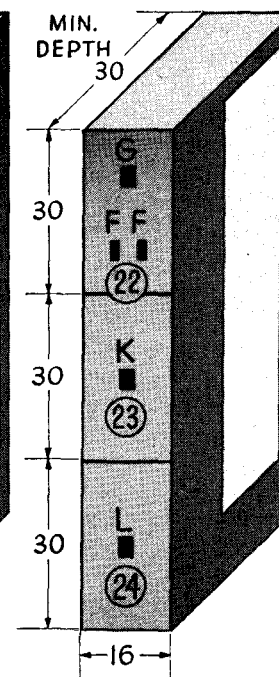

Fig. 14

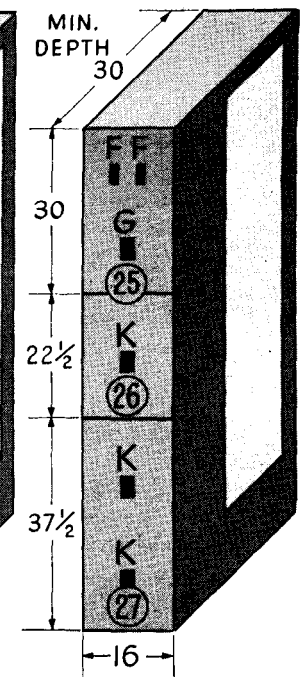

Fig. 15

NOTE—One "K" Frame can be substituted for the Two "F" Frames in Section (13) Fig. 11

EXAMPLE AND SOLUTION

Assuming switchboard with 2 services: Lighting—3 phase, 4-wire, 120/208 volts. Power—3-phase, 3-wire, 480 volts, the following are required:

POWER SECTION TO HAVE

Space only for power company meters

- 1—1600A 3P DA50 main breaker
- 1— 800A 3P feeder breaker
- 2— 275A 3P Type AB (L frames)
- 1— 450A 3P (L frame)
- 1— 125A 3P (K frame)
- 2— 50A 3P (F frames)
- 2— 25A 2P (F frames)

LIGHTING SECTION TO HAVE

Space only for power company meters
Blank 30" x 26" wide panel for equipment to be mounted by customer.

- 1—1600A 3-pole DA50 main breaker
- 10—150A 3-pole Type AB breakers (K frames)
- 4—100 (F frames)
- 4—50 (F frames)

The finished layout using panel layouts and dimensions as shown on pages 8 and 9 appears at right.

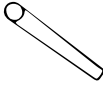
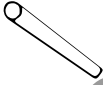
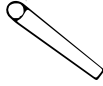
| | | | | |
|---|--|---|---------------------------------------|---|
| Power Section Meter Space | 2-50A. 3P. 2-25A. 2P. ① Fig.7 Page 8 □ □ □ □ | Lighting Section Meter Space | 2-150A. 3P. □ □ ⑨ Fig. 9 Page 8 | 4-50A. 3P. □ □ □ □ ② Fig.7 Page 8 □ □ □ □ 4-100A. 3P. |
| 1600A. 3P. DA-50 Fig. 4 Page 9  | 1-450A. 3P. 1-125 A. 3P. □ □ ⑩ Fig. 10 Page 8 | 1600A. 3P. DA-50 Fig.4 Page 9  | 2-150A. 3P. □ □ ⑨ Fig. 9 Page 8 | 2-150A. 3P. □ □ ⑨ Fig. 9 Page 8 |
| 800A. 3P. DA-50 Fig. 4 Page 9  | 2-275 A. 3P. □ □ ⑪ Fig. 11 Page 8 | Space for Customers Equipment | 2-150A. 3P. □ □ ⑨ Fig. 9 Page 8 | 2-150A. 3P. □ □ ⑨ Fig. 9 Page 8 |

TYPICAL SPECIFICATIONS

Switchboard shall consist of a completely enclosed, self-supporting metal structure containing fixed-type circuit breakers and any other associated equipment as indicated on the plans. The switchboard shall consist of the required number of formed and welded sheet steel enclosures required to mount circuit breakers and other equipment. Bolted frames shall be provided at the rear to support and house copper bus, cables, instrument transformers, and other details. The switchboard shall be completely enclosed on front, sides, top, and rear with removable sheet plates not less than 12 gauge excepting that removable front sections over breakers may be 14 gauge. All fastenings between structural members shall be bolted, not welded, in order to provide flexibility during installation. The construction of the front cubicles shall be such that air breakers above 600 amperes will be isolated from adjacent breakers by means of barriers.

VENTILATION—The rear enclosing sheets and all front covers for breakers above 600 amperes shall be provided with ventilating grille work. Louvres will not be acceptable.

FINISH—Switchboard shall be finished with a light gray for exterior and interior surfaces and all sheet steel parts shall be rust-proofed after fabrication and prior to painting.

CIRCUIT BREAKERS—Where the interrupting capacity requirements of the job permit, Westinghouse Nofuze type AB circuit

breakers or equal shall be used on all circuits 600 amperes and below. All type AB breakers shall be provided with rear connected studs on both line and load terminals. Solderless terminals shall be provided on load studs for feeder connections. Circuit breakers above 600 amperes shall be Westinghouse type DA.

All breakers shall be of the stationary type. Thermal type AB breakers shall be so mounted that they can be removed without disturbing studs, bus work, or having to disconnect load cables. Where future type AB breaker space only is called for, all studs, copper work, and provisions for mounting the breaker shall be provided so that when the breaker is added, no additional parts or changes to the structure or bus work are required.

Access to type AB breakers shall be by removing screwed-on flanged front covers. Front covers on type DA breakers shall be hinged. Butt joints on front covers will not be acceptable.

ALL BUSSES, SWITCHING DEVICES AND CONNECTIONS shall be of sufficient size to limit the temperature rise to 30°C over an ambient temperature of 40°C inside the enclosure and all bus contact surfaces shall be silverplated. All bus connections shall be bolted. All bus work and connections shall be accessible for inspection and maintenance purposes from ends and rear after first removing respective enclosing plates.

The entire switchboard structure shall be securely fastened to channel iron sills grouted into and set flush with the floor.

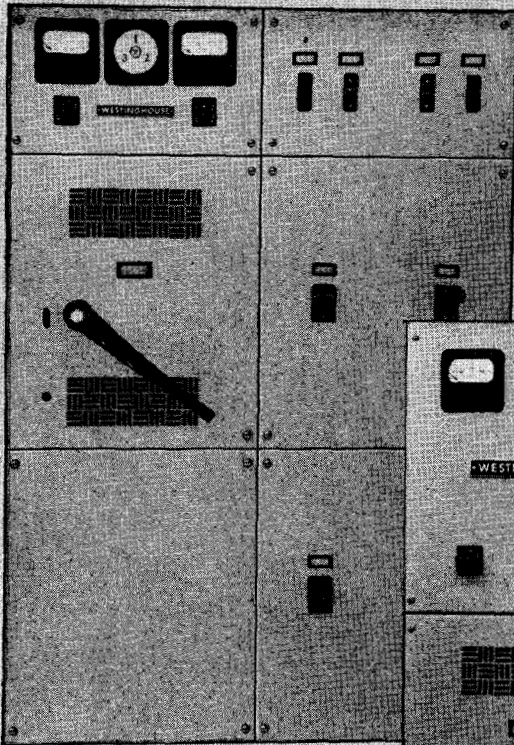

75 1/2 Inch High Switchboard with DA-50 and AB Types "F", "K" and "L" Frames Manually Operated Circuit Breakers.

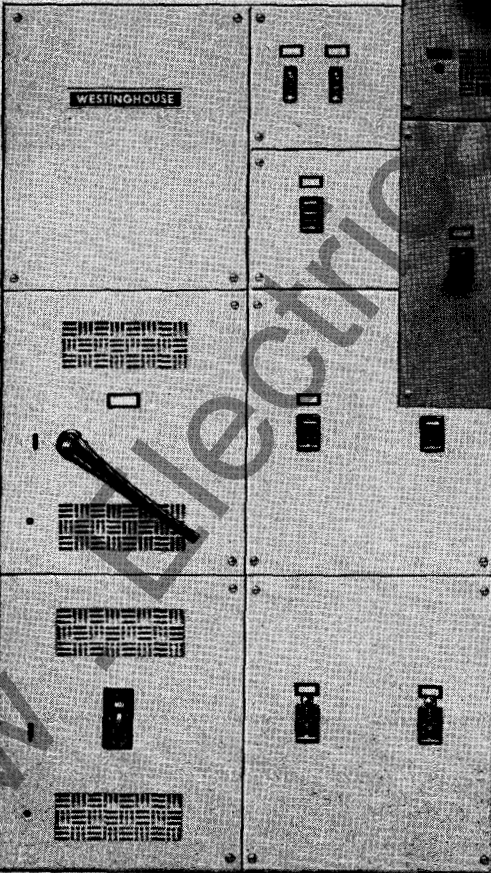

90 1/2 Inch High Switchboard using DA-50 and AB Types F, G, K and L Frames Manually Operated Circuit Breakers.



90 1/2 Inch High Switchboard Employing DA-50, DB-25 and AB Types F, G, K and L Frames Manually Operated Circuit Breakers.

www.ElectricalManuals.com

Typical Installation of "Building-Type" Distribution Switchboard Using "L" Frame Type AB De-ion, DB and DA Manually-Operated Circuit Breakers with Flush Instruments. Note Blank Panels Permitting Future Addition of Circuit Breakers.

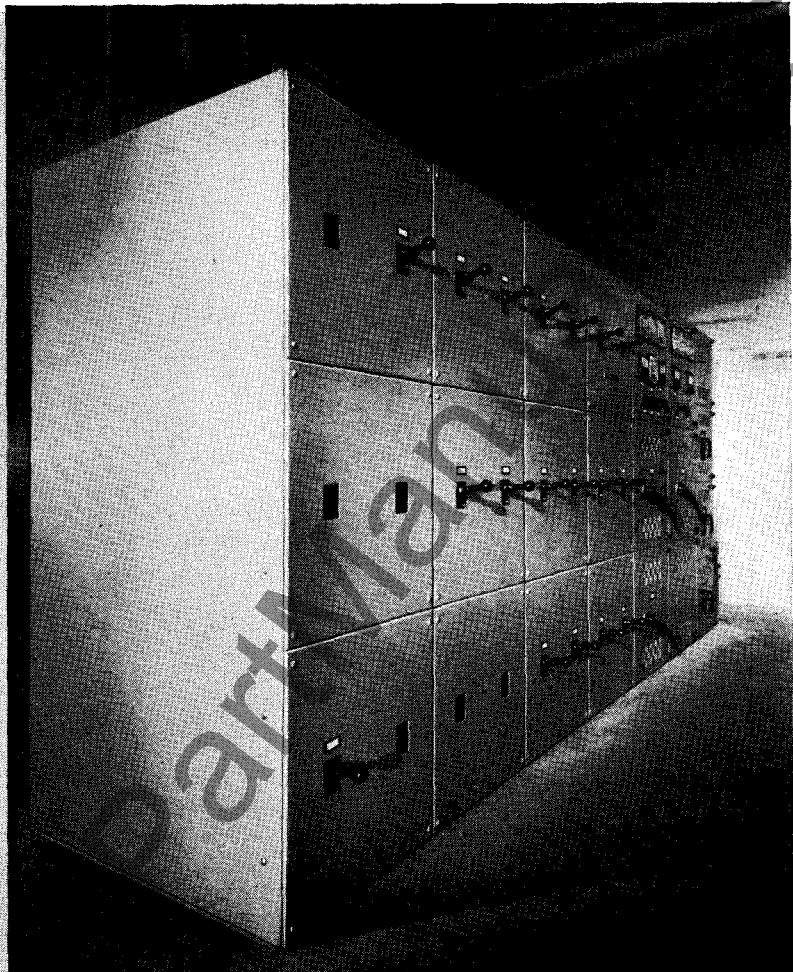

NATION-WIDE LOCALIZED SERVICE

14 Shops Assemble Westinghouse "Building Type" Switchboards

In order to provide quick delivery on Westinghouse switchboards, there are fourteen assembly shops located at strategic points throughout the United States. Each one of these shops is equipped to manufacture and assemble building type switchboards built to the designs incorporated in this book. Whether your switchboard is built in our Boston or San Francisco shop, you get the same board with equal quality and uniformity.



LITERATURE REFERENCE

PRICES—Refer to Nearest Westinghouse Office.



WESTINGHOUSE ELECTRIC CORPORATION
DISTRICT M&R PLANT • PANELBOARD HEADQUARTERS • HILLSIDE, N. J.

Printed in U.S.A.