

WESTINGHOUSE SPECIAL FEATURES

CONTROL SWITCHBOARDS provide centralized operation of switching equipment located throughout the generating plant or substation. Control, indicating, recording, regulating, and protective equipments are mounted on factory-assembled dead-front switchboards, with separate control desks or benchboard designs where desired.

Westinghouse control switchboards are available in eight designs, as standardized by the National Electrical Manufacturers Association:

1. **Vertical Switchboard**.....Page 2
2. **Enclosed Switchboard**.....Page 2
3. **Dual Switchboard**.....Page 3
4. **Duplex Switchboard**.....Page 3
5. **Control Desk**.....Page 4
6. **Benchboard**.....Page 4
7. **Dual Benchboard**.....Page 5
8. **Duplex Benchboard**.....Page 5

1. **COMPACT, FACTORY-ASSEMBLED UNITS**, with all equipment mounted and wired, simplify installation.
2. **MODERN APPEARANCE** of semi-flush mounted instruments, relays, meters and other equipment results in an attractive switchboard.
3. **COORDINATED APPARATUS** includes correct complement of indicating equipment, relays, control switches, meters and auxiliary devices.
4. **EASY ACCESSIBILITY** to inside of switchboard is provided through hinged panels and aisles.
5. **DEAD-FRONT CONSTRUCTION** provides maximum safety for operating personnel.
6. **REMOVABLE END TRIMS** permit extension of switchboard at either end.
7. **STANDARD DESIGNS** mean lower installed cost and shorter delivery.

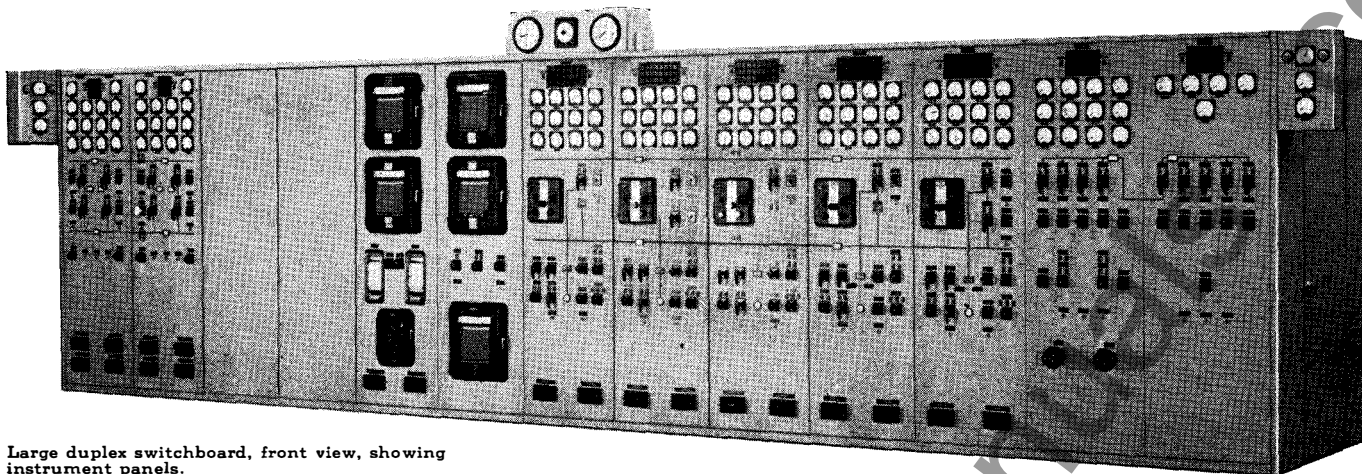

Large duplex switchboard, front view, showing instrument panels.

1 VERTICAL SWITCHBOARD

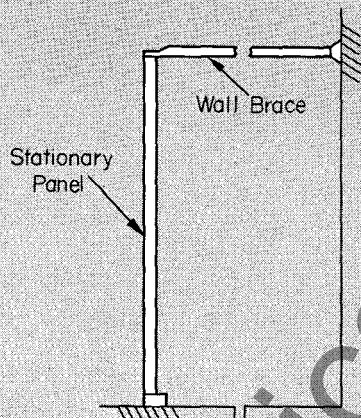

VERTICAL SWITCHBOARD... A dead-front (having no exposed live parts on the front) switchboard composed of standard, vertical, sheet-steel panels, the required number being bolted together, side by side, to form a complete assembly. The panels are bolted to structural-steel base channels for the Purchaser to secure to the foundation; fittings for wall braces are provided at the top of the panels. Each panel consists of a cold-rolled, stretcher-leveled steel sheet, approximately $\frac{1}{8}$ -inch thick, formed with angle sections at the top and bottom and channel sections at the sides. All corners are welded to increase the rigidity of the section and ground smooth to assure good appearance. The angle sections provide for bolting to the top strip and bottom channel. The channel-shaped sides provide all necessary vertical framing facilities for tie bolts between panels and serve as raceways for vertical wiring. The wiring raceways, which may be either three or six inches wide, are equipped with covers so that the vertical wiring is concealed and protected. Standard panel widths are 12, 16, 20, 24, 28, and 32 inches, with either three or six-inch wiring channels available in the standard 90-inch high panels and three-inch channels in the 76-inch high panels. Terminal blocks for the Purchaser's outgoing control wires are mounted either at the top or bottom rear, as required by the conduit location

2 ENCLOSED SWITCHBOARD

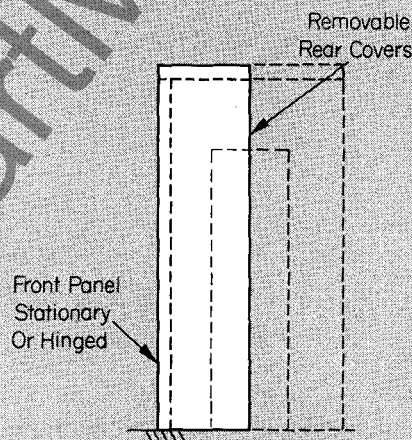

ENCLOSED SWITCHBOARD... A dead-front switchboard which has an overall sheet-metal enclosure (not grille) covering the rear, top and ends of the entire structure. It is made in the following two designs:

A. WITH STATIONARY FRONT PANELS. Essentially a vertical switchboard furnished with a rear enclosure to make it self-supporting. The rear covers are bolted on, and the enclosing end sheets may have hinged doors to permit access to the interior. The standard section widths are 20, 24, 28 and 32 inches with a height of 90 inches. If end access doors are required, the standard depth is 36 inches. When access is through the removable rear covers, the standard depth is 24 inches.

B. WITH HINGED FRONT PANELS. Where space is at a premium (necessitating a shallower board), or where access to the interior can only be obtained from the front, the enclosed type switchboard will be constructed with hinged front panels. Each section is an individual cubicle, with steel side sheets extending the full height and depth of the section. A formed metal wiring trough extends the length of the board for inter-panel wiring. The rear covers are bolted on, and the end sheets are solid, without access doors. Standard section widths are 20, 24, 28, and 32 inches, with a height of 90 inches and a standard depth of 24 inches.

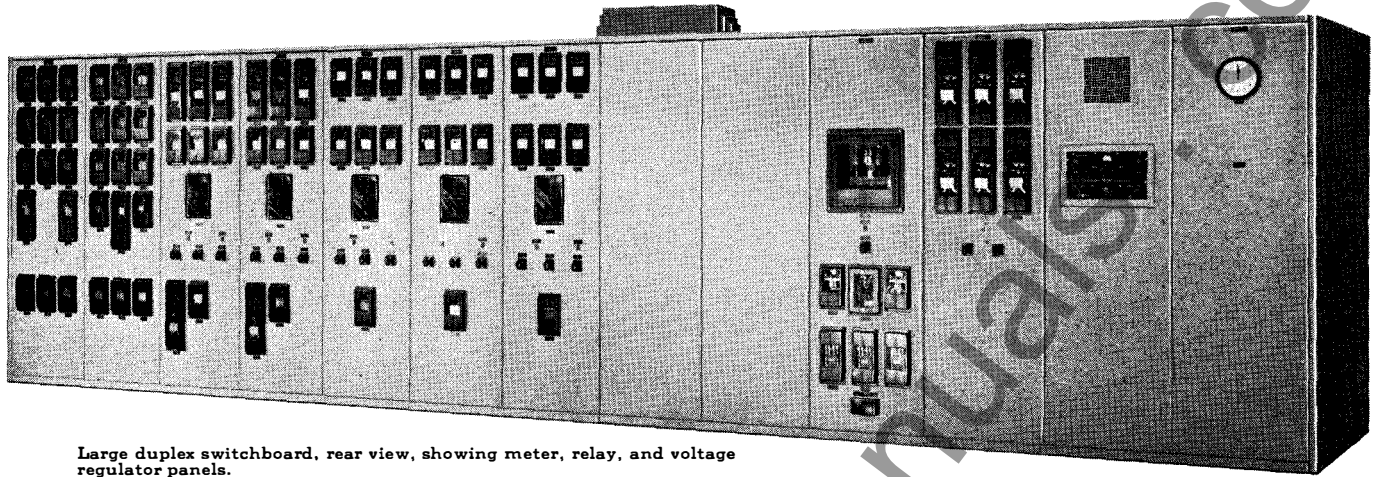

Large duplex switchboard, rear view, showing meter, relay, and voltage regulator panels.

3 DUAL SWITCHBOARD

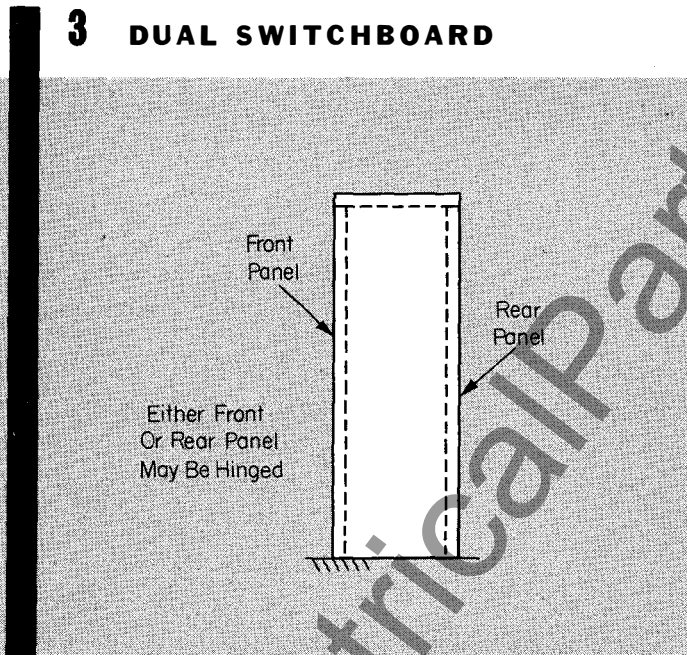

DUAL SWITCHBOARD . . . A structure with dead-front panels on the front and rear, separated a comparatively short distance and enclosed at both top and ends. Either the front or rear panels may be hinged. The accepted arrangement is to mount the indicating instruments and control devices on the hinged panels and the protective relays on the stationary panels. Each section is an individual cubicle, with steel side sheets extending the full height and depth of the section. The side sheets serve as tie members between the front and rear panels, and also support terminal blocks and auxiliary equipment. A longitudinal wiring trough carries the wiring between panels. Standard section widths are 20, 24, 28, and 32 inches, with a height of 90 inches and standard depths of 30 and 36 inches.

4 DUPLEX SWITCHBOARD

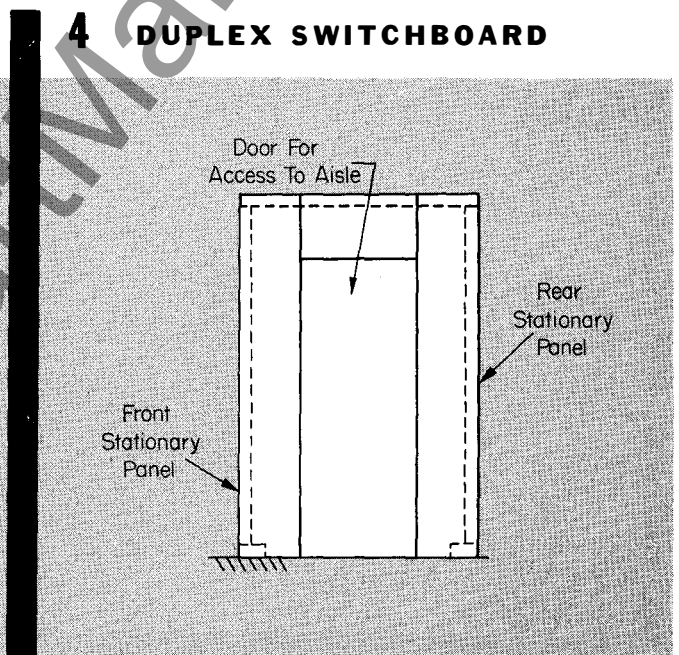

DUPLEX SWITCHBOARD . . . A self-supporting structure consisting of standard stationary panels located in a back-to-back arrangement, with access space at the rear of the panels in the form of an aisle extending the length of the board. The top and ends are enclosed, with hinged doors in the ends providing access to the interior of the switchboard. Formed metal troughs are provided for the wiring between front and rear panels and for inter-panel wiring. Provisions are made for adequate interior lighting; and three-way light switches, together with convenience receptacles, are located inside each end access door. Standard section widths are 16, 20, 24, 28, and 32 inches, with a height of 90 inches and standard depths of 60 and 72 inches.

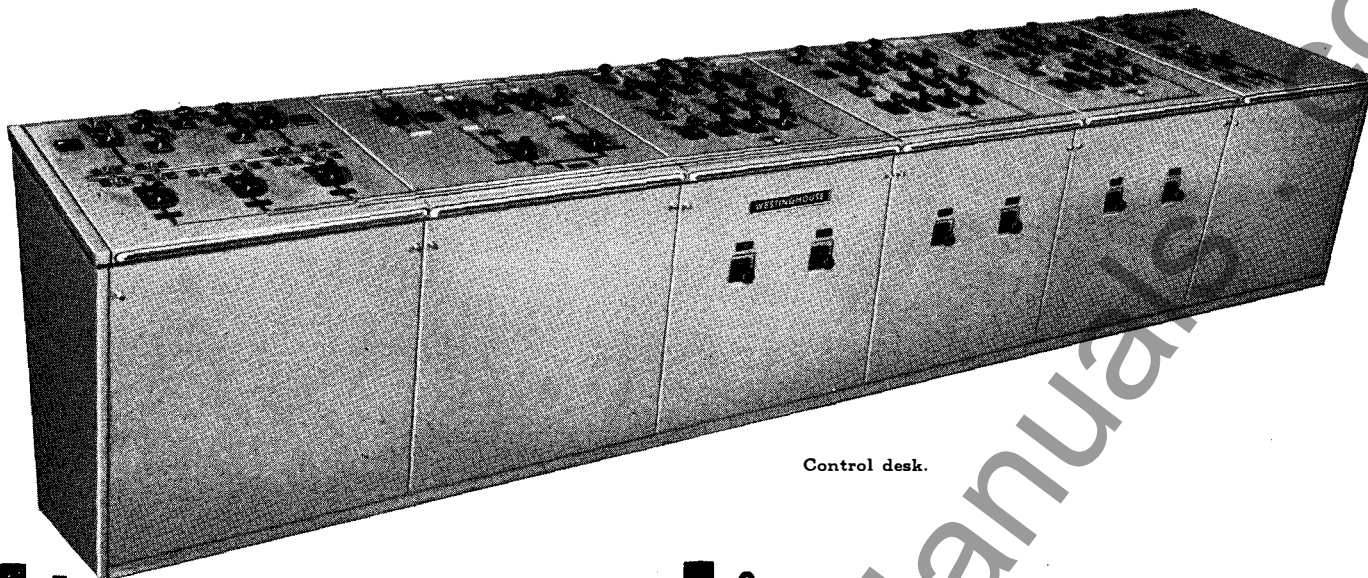

Control desk.

5 CONTROL DESK

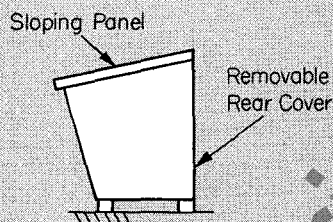

CONTROL DESK... A switchboard having inclined panels mounted on a structure of such height that the panel-mounted control devices are within convenient reach of the operator. Each desk section is constructed with a welded steel framework, enclosed by formed sheet-steel sloping and front apron panels and removable rear covers. The top panel is inclined upwards 15° from front to back so that, when the operator is facing the desk, all indicating lights, mimic bus, and control devices are readily visible. The front apron panel is inclined 15° from top to bottom to provide toe space for the operator. The steel side sheets in each section provide space for terminal blocks and auxiliary equipment. A vertical wiring duct is provided on the side sheet adjacent to the terminal blocks, and a horizontal wiring trough extends the full length of the structure. Complete accessibility to all wiring and devices in the interior of the switchboard is provided through the removable apron panel on the front and the removable rear covers. Standard unit widths are 20, 24, 28, and 32 inches; the standard height at the rear is 40 inches.

6 BENCHBOARD

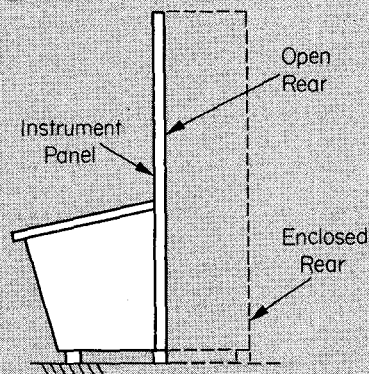

BENCHBOARD... A combination of a control desk and a vertical or enclosed switchboard, with the inclined section touching the vertical section. The features of the control desk and vertical or enclosed switchboard described previously apply also to this type of construction.

When an enclosed switchboard is part of a benchboard, it is, of course, the type with stationary front panels and removable rear covers.

DUAL BENCHBOARD... A combination of a control desk and a dual switchboard with hinged rear panels. The instrument and control switches are mounted on the inclined panel, the indicating instruments are on the front vertical panels, and the protective relays are on the hinged rear doors. There is no interior aisle in this type of construction; interior access is obtained through the hinged rear doors.

DUPLEX BENCHBOARD... A combination of a control desk and a duplex switchboard, with an interior aisle extending the length of the structure. The instrument and control switches are mounted on the inclined panel, the indicating instruments are on the front vertical panels, and the protective relays are on the stationary rear panels.

Dual Benchboard with swinging panel.

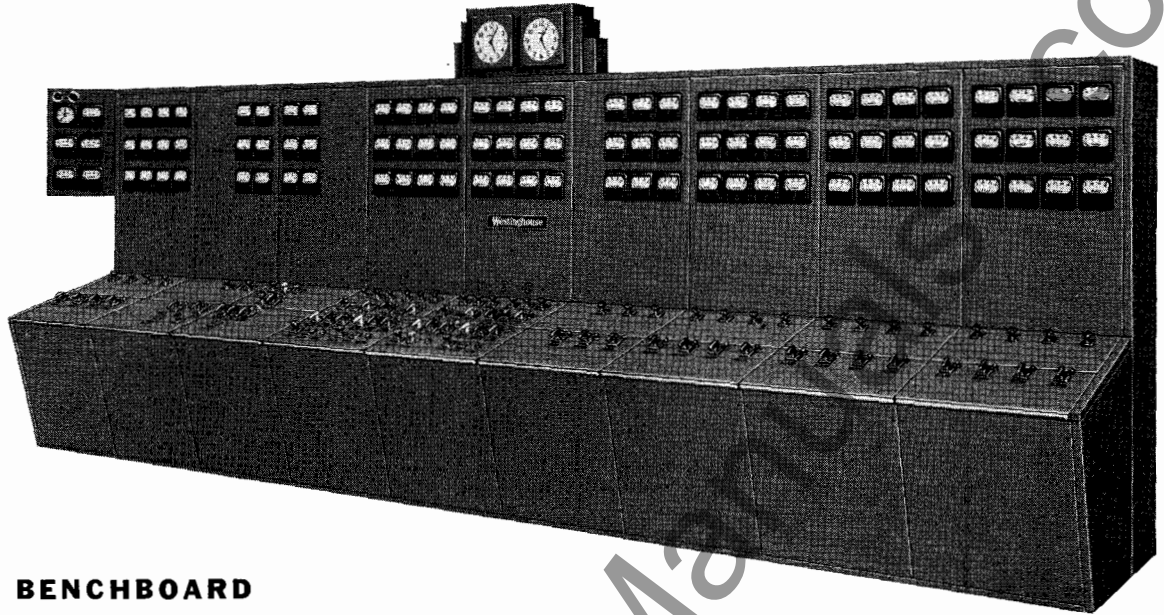

7 DUAL BENCHBOARD

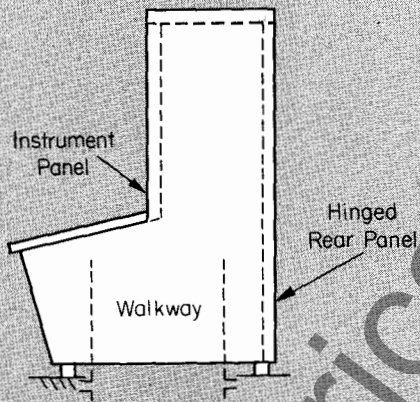

8 DUPLEX BENCHBOARD

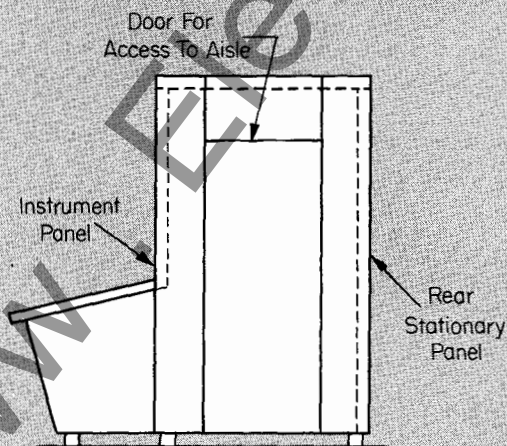

EASY ACCESSIBILITY

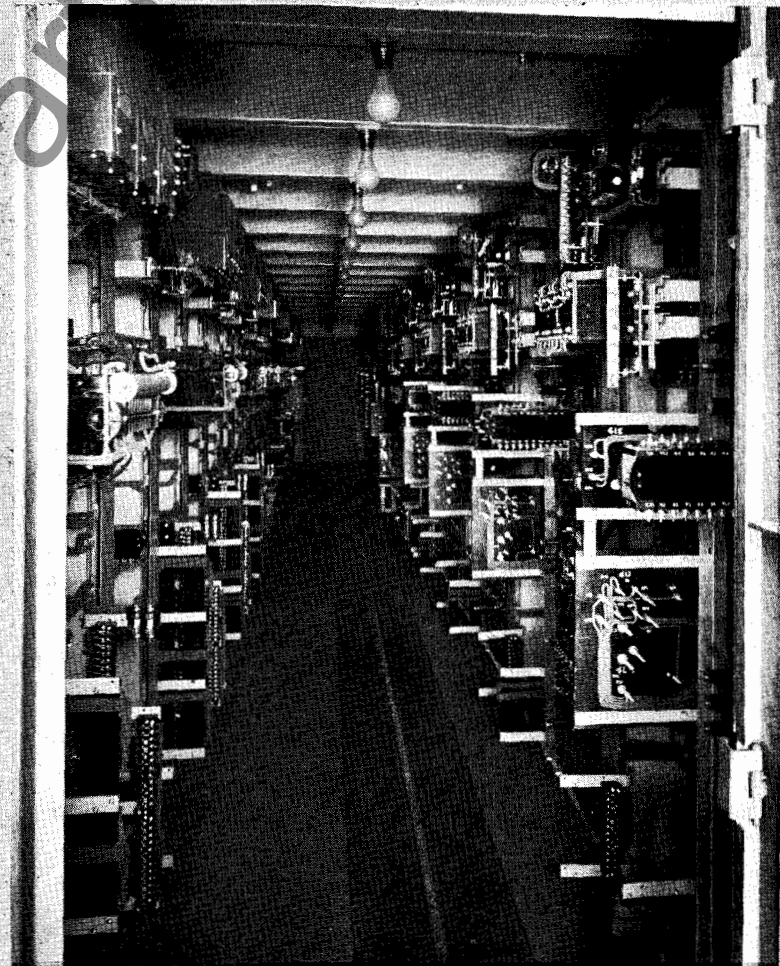

INTERIOR AISLEWAY provides easy access to duplex switchboards. Wiring and other interior details are accessible through hinged or removable panels in enclosed or dual designs.

Switchboard instruments, meters and relays are mounted in semi-flush rectangular cases, finished a dull black, with a harmonious, pleasing modern appearance. For switchboard devices not described here (such as voltage regulators, field rheostats, recording instruments, and miniature bus indication) refer to your Westinghouse District Office.

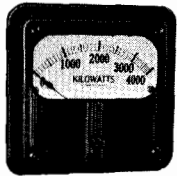

Type K-25 instrument.

INDICATING INSTRUMENTS

Two complete lines of switchboard instruments are available: Type K-25, with rectangular dial, and Type K-24, with round dial. Both instruments have permanently white, clear, readable dials with black markings and pointers.

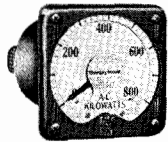

Type K-24 instrument.

The movements in these instruments are designed to provide high overload capacity. Non-ageing springs, permanent magnets, low-friction pivots and exceptionally uniform a-c scales are other Westinghouse features.

WATTHOUR METERS

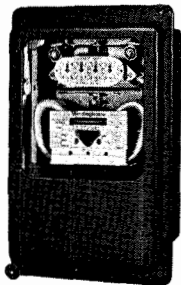

Type CB-F meter.

Type CB-F induction-type watthour meters are equipped with Flexitest built-in knife-blade test switches. The meter elements are mounted on a removable unit chassis to permit convenient testing and maintenance. Test connections are made either by clip leads or test plug.

These meters have high accuracy from light loads to heavy overloads, making them suitable for the most exacting requirements. The meter register utilizes gold-finished milled involute gears. The frame is finished to prevent corrosion, the vertical shaft runs on a ball and jewel bearing, and the entire construction reduces friction to a minimum.

PROTECTIVE RELAYS

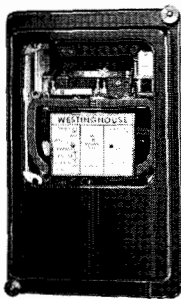

Type CO relay.

Flexitest cases with built-in knife-blade test switches facilitate testing and maintenance. The relays may be tested on the switchboard by either clip leads or test plugs. When it is necessary to remove the relay for laboratory testing, the chassis can be easily removed and a spare substituted.

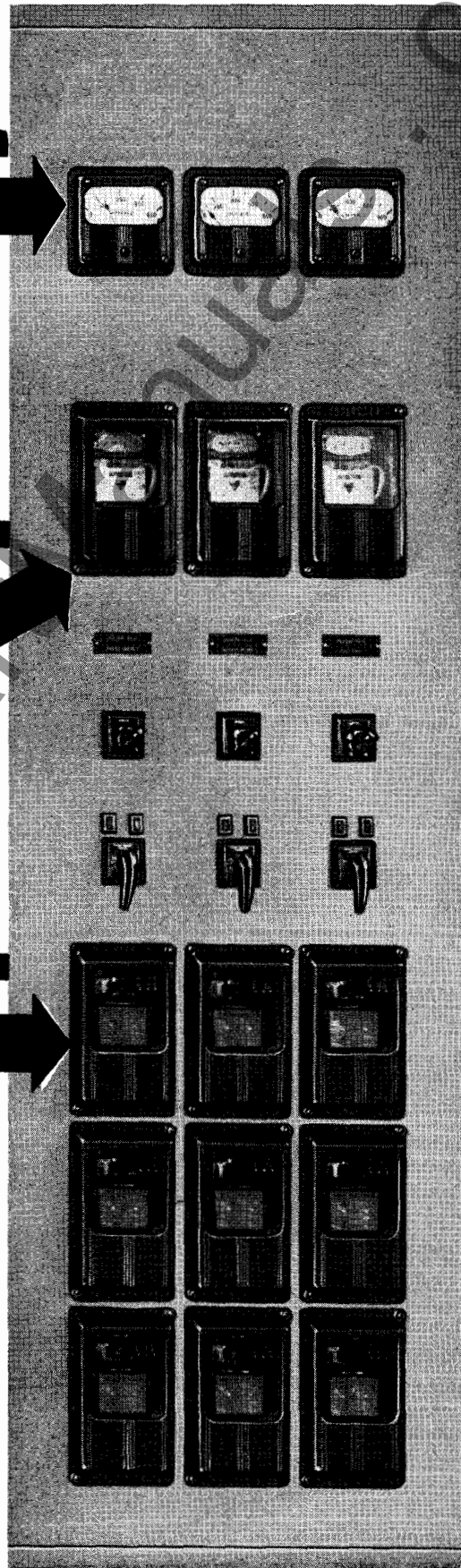

Flexitest Cases Give Choice of Testing Procedure

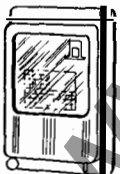

Dust-tight cover.

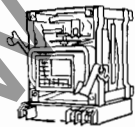

Removable relay chassis

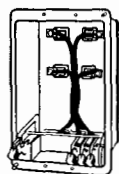

Permanently mounted case.

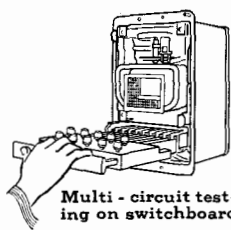

Multi-circuit testing on switchboard

ANNUNCIATORS

Two types of annunciators are available with either 1" x 1" or 2 1/4" x 3 1/4" windows.

Normally-open control relays indicate "trouble" when their contacts close the illuminating lamp and audible alarm circuits. A common silencing switch will stop the audible alarm without preventing the alarm from functioning on subsequent "trouble". Illumination of the designation continues until a common reset switch is pressed; however, the lamp cannot be permanently extinguished until the "trouble" contacts return to their normally-open position. A test pushbutton is furnished for the simultaneous testing of all lamp circuits.

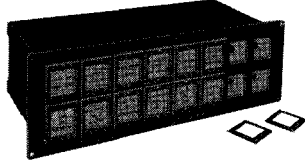

Annunciator with 1" x 1" designations.

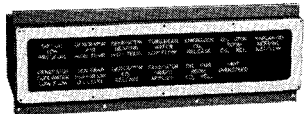

Annunciator with 2 1/4" x 3 1/4" designation.

Lamps and designations are accessible from the front of the switchboard to facilitate lamp replacement or changes of designation.

Control switch and indicating lamps mounted together.

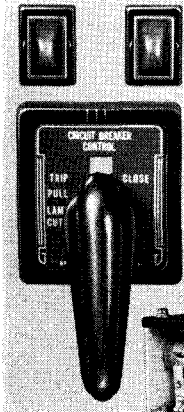

INDICATING LAMPS AND SWITCHES

RECTANGULAR MINALITE® INDICATING LAMPS provide extreme angular visibility in a design which matches other switchboard devices. Slide base bulbs and glass lenses, available in a variety of colors, are replaceable from the front of the panels.

TYPE W INSTRUMENT AND CONTROL SWITCHES have rotary enclosed silver-plated contacts. Control switches have pistol-grip, spring-return handles, and the necessary closing, tripping alarm, and lamp cutout contacts. Instrument switches have round notched handles for 360° manipulation.

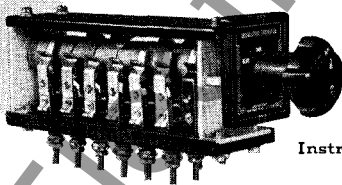

Instrument switch

FLEXITEST TEST SWITCHES

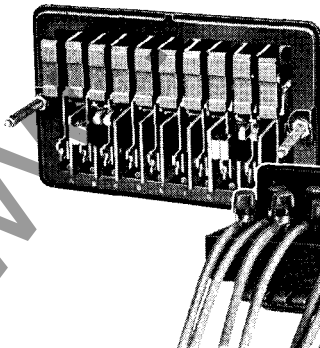

(Left) Flexitest switch, cover removed.

(Below) Test plug inserted for testing.

Type FT Flexitest switches provide rapid, reliable multi-circuit testing of switchboard instruments, meters, and relays. The switch is built in a maximum of 10 circuits, with test plugs to match.

When the test plug is used, any number of circuits may be tested in rapid succession, since one plug properly connected can test all instruments or meters of a particular type. Plugs are available for either separate source or series testing. For maximum flexibility, spring clip leads can be used in place of the test plug. The individual knife switches can be operated independently, or two or more can be interlocked for testing requirements.

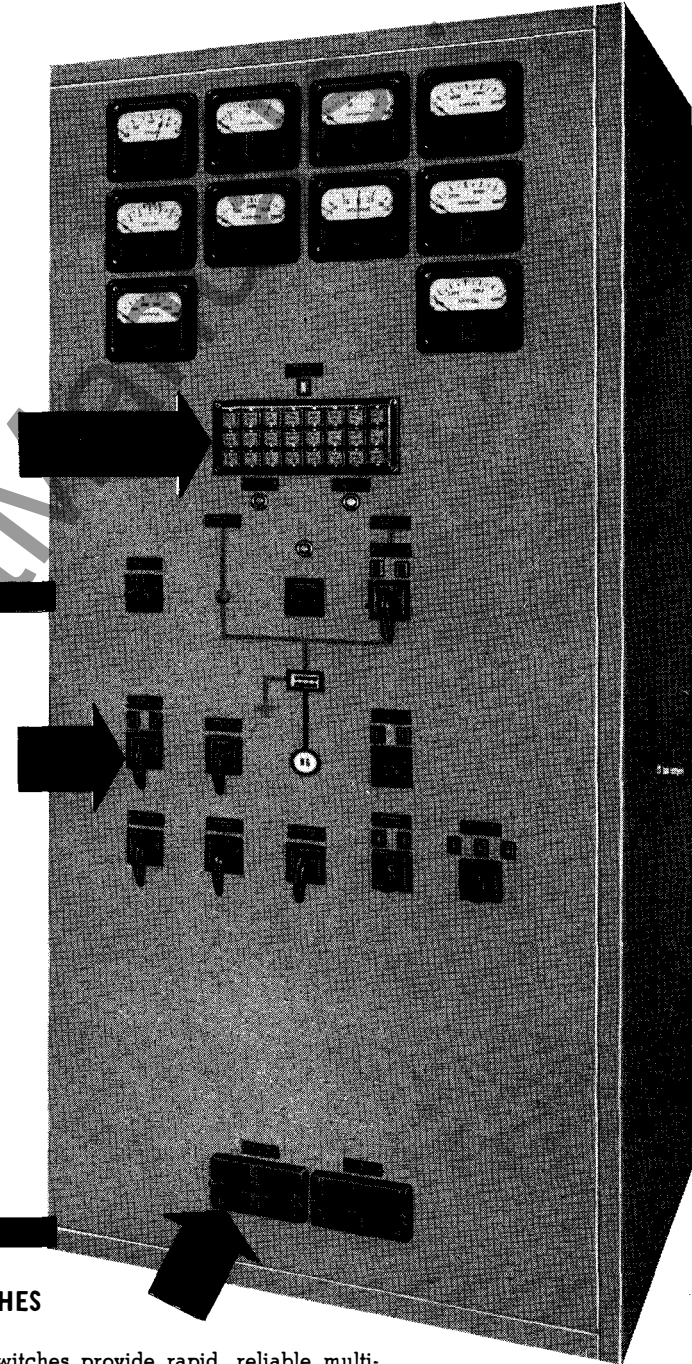

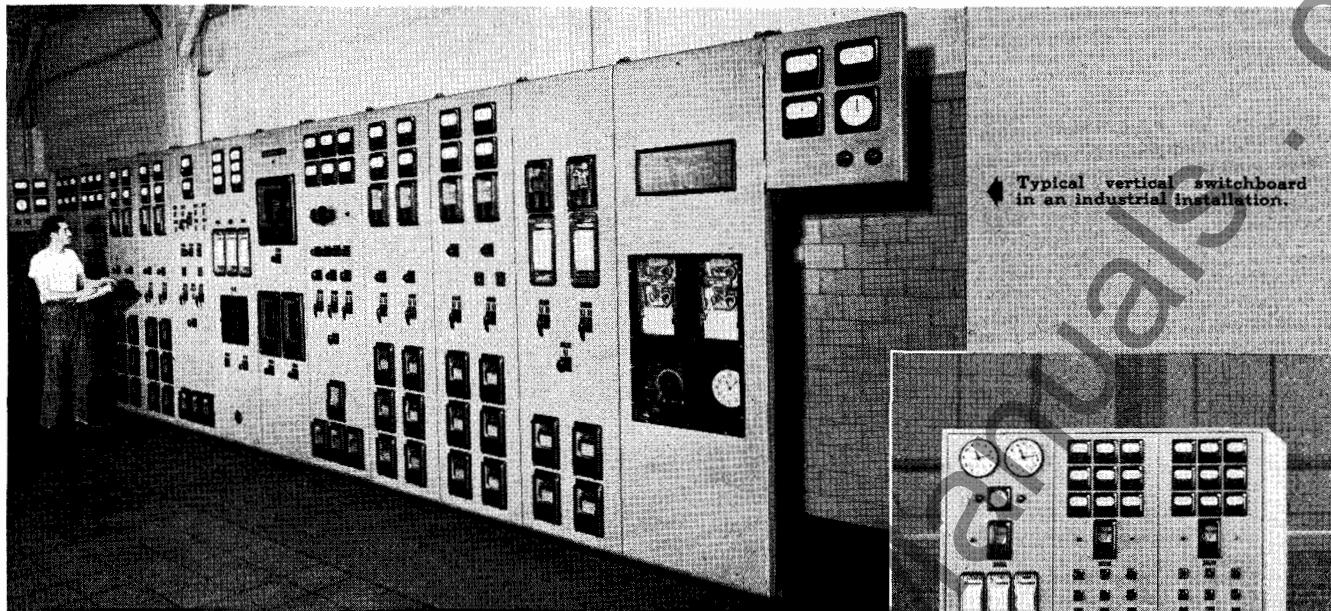

Typical vertical switchboard in an industrial installation.

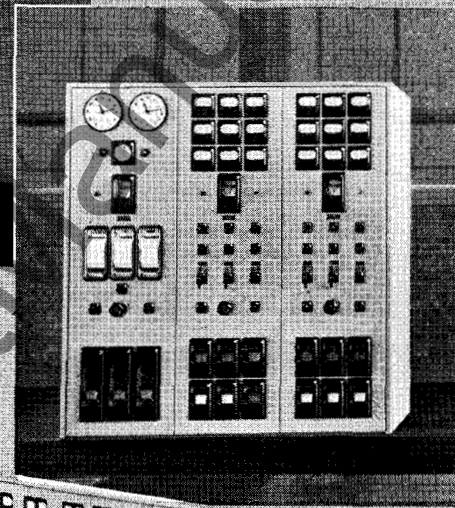

Typical enclosed switchboard.

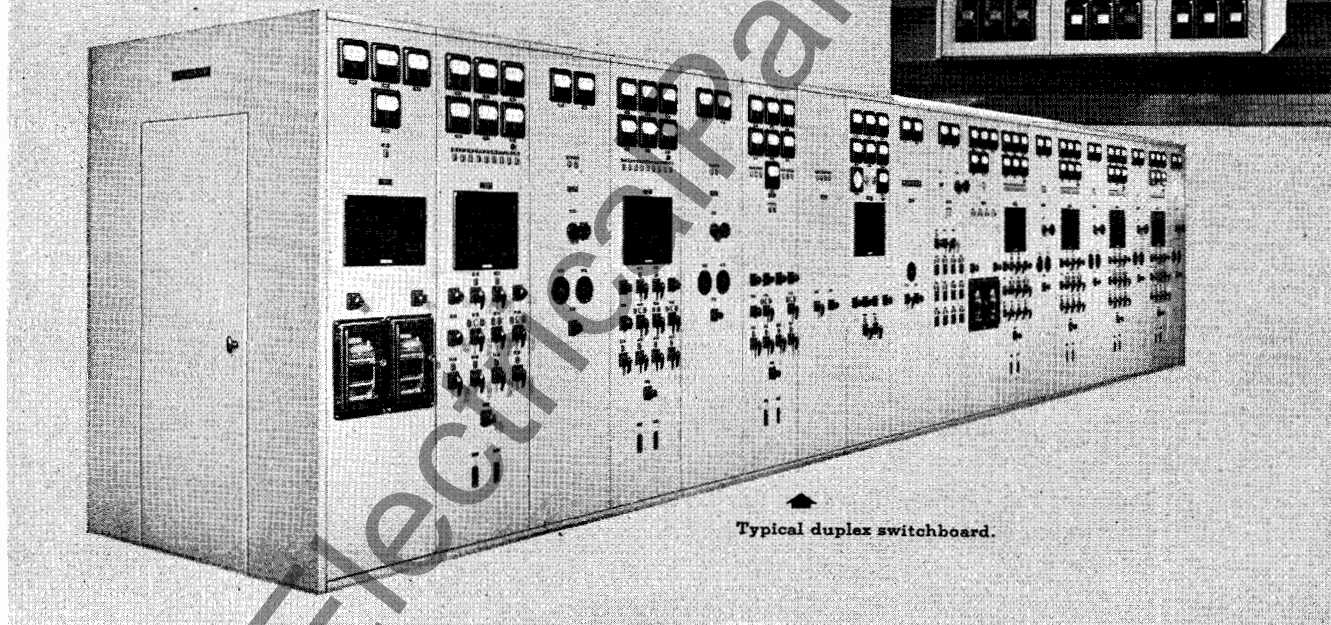

Typical duplex switchboard.

LITERATURE REFERENCE

PRICES

Refer all negotiations to Westinghouse

DESCRIPTION

- SWITCHBOARD INSTRUMENTS—Refer to Catalog Section 43-200
- TYPE CB-F WATTHOUR METERS—Refer to Catalog Section 42-104
- PROTECTIVE RELAYS—Refer to Index 41-000
- INDICATING LAMPS—Refer to Catalog Section 37-200
- INSTRUMENT AND CONTROL SWITCHES—Refer to Descriptive Bulletin 37-150
- FLEXITEST SWITCHES—Refer to Catalog Section 37-225
- VOLTAGE REGULATORS—Refer to Price List 31-220



WESTINGHOUSE ELECTRIC CORPORATION
 EAST PITTSBURGH PLANT • SWITCHGEAR DIVISION • EAST PITTSBURGH, PA.

Printed in U.S.A.