

### Primary or Secondary Unit

#### GENERAL

Cooper Power Systems Primary or Secondary Unit Substation Transformers are designed to meet exact customer specifications. Flexibility in design, combined with the highest quality manufacturing processes and equipment, enable Cooper Power Systems to provide a product optimized to the customer's requirements. All units meet applicable ANSI, NEMA, IEEE Standards and NEC® and CEA specifications.

Unit substation transformers are available with enclosed sidewall-mounted bushings for connections to primary and/or secondary switchgear.

Substation transformers are made with a wide range of core steels and winding conductors to meet total owning cost or material requirements. Flexible core and tank construction enables your dimensional requirements to be met.

Cooper Power Systems transformers are available with standard electrical grade mineral insulating oil or other dielectric coolants manufactured by Cooper Power Systems.

Unit substation transformers intended for indoor use are filled with R-Temp® fluid, a less-flammable, high molecular weight hydrocarbon with a flawless fire safety record. Electrical codes recognize the advantages of using R-Temp fluid both indoors and outdoors for fire sensitive applications. R-Temp fluid-filled units meet OSHA and Section 450-23, 1996 NEC requirements. Transformers intended for outdoor applications may be filled with R-Temp fluid or normally formulated hydro-refined mineral oil.



**Figure 1.** Secondary unit substation transformer equipped with transition flange and full length cabinet.

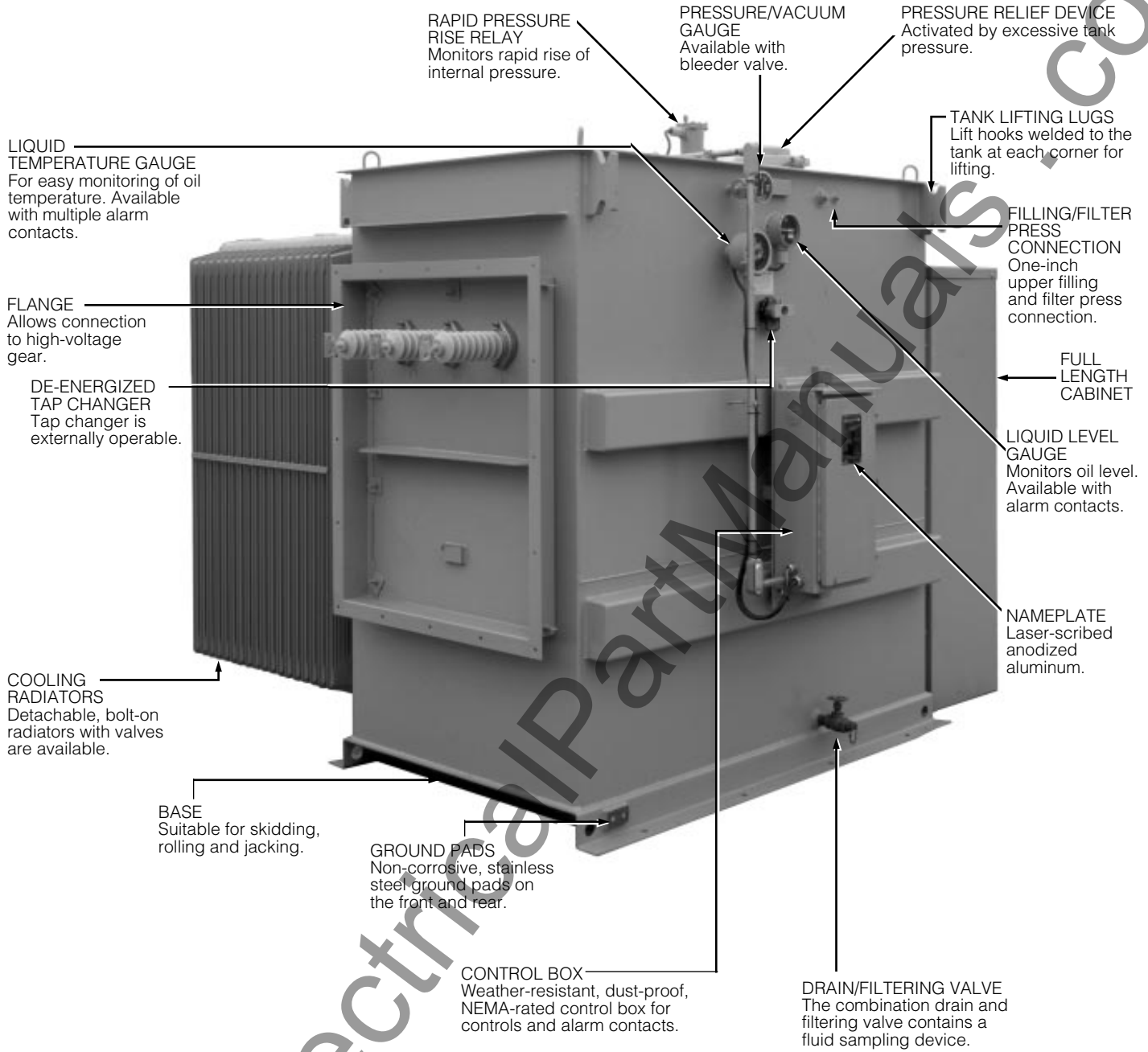

**Figure 2.**  
Secondary unit substation transformer with standard features and optional accessories.

**STANDARD FEATURES**

- De-energized tap changer, externally operable
- Extra-heavy, welded-in-place lifting lugs and jack pads
- Sidewall mounted high-voltage porcelain bushings
- Sidewall mounted low-voltage molded epoxy bushings with NEMA six-hole spades
- Tank bases designed to allow skidding or rolling in any direction
- One-inch upper filling plug with filter press connection
- One-inch combination drain/filtering valve with sampling device
- Available in ANSI #61 Light Gray or ANSI #70 Sky Gray
- Tank interior is painted light gray, improving visibility for field inspection and servicing
- Pressure test connection
- Dial-type thermometer
- Dial-type liquid level gauge
- Pressure vacuum gauge
- Stainless steel grounding pads
- Laser-scribed anodized aluminum nameplate
- Cooling radiators are welded directly to the tank
- Standard grade mineral insulating oil (for outdoor applications)
- Pressure relief device

**OPTIONAL ACCESSORIES**

- Primary and secondary termination enclosure options
  - Throat
  - Flange
  - Top- or bottom-entry air terminal chamber
  - Top- or bottom-entry full length cabinet
- Pressure vacuum bleeder valve
- Cover mounted pressure relief device (for oil-cooled units; standard with R-Temp units)
- Detachable, bolt-on radiators with valves
- Monitoring devices
  - Dial-type thermometer with alarm contacts (standard with FA Fan Package)
  - Liquid level gauge with alarm contacts
  - Pressure/vacuum gauge with alarm contacts
  - Cover mounted pressure relief device with alarm contacts
  - Rapid pressure rise relay
    - Optional seal-in panel
- Winding temperature indicator with alarm contacts
- R-Temp less-flammable fluid and other environmentally desirable fluid options
- Primary air disconnect switch
- Forced air fan control package
  - Package includes fans, NEMA 3R control box, fan controls, dial-type thermometer with alarm contacts.
- Nitrogen blanket with purge valves (3 psi)
- Control box

**PROTECTION OPTIONS**

- Surge arresters
  - Distribution, intermediate, or station class
- Kyle® Vacuum Fault Interrupter (VFI)

**ELECTRICAL DATA**

**TABLE 1**  
Three-phase, Single Temperature kVA Ratings

Three-phase kVA Self-cooled and forced-air cooled with 65° C temperature rise		
65° C Rise OA		65° C Rise OA/FA
500	} +15%	575
750		862
1000		1150
1500		1725
2000		2300
2500	} +25%	3125
3750		4687
5000		6250
7500		9375
10000		12500

**TABLE 2**  
Percent Impedance Voltage<sup>1</sup>

kV BIL Class	Low Voltage	
	< 2400 V	≥ 2400 V
45-150	5.75 <sup>2</sup>	6.50 <sup>3</sup>
200	7.25	7.00
250	7.75	7.50

<sup>1</sup> The standard tolerance is ± 7.5%.  
<sup>2</sup> Option for 6.75% is available.  
<sup>3</sup> Option for 5.50% is available.

**TABLE 3**  
Audible Sound Levels

Self-cooled, Two Winding kVA Rating	NEMA Average	
	dB, OA	dB, FA
500	56	67
501-700	57	67
701-1000	58	67
1001-1500	60	67
1501-2000	61	67
2001-2500	62	67
2501-3000	63	67
3001-4000	64	67
4001-5000	65	67
5001-6000	66	68
6001-7500	67	70
7501-10000	68	71

**TABLE 4**  
Three-phase, Dual Temperature kVA Ratings

Three-phase kVA Self-cooled and forced-air cooled with dual rated 55/65° C temperature rise			
55° C Rise OA		55° C Rise OA/FA	65° C Rise OA/FA
500	} +12%	575	644
750		862	965
1000		1150	1288
1500		1725	1932
2000		2300	2576
2500		2800	3500
3750		4200	5250
5000		5600	7000
7500		8400	10500
10000		11200	14000

**TABLE 5**  
Insulation Test Levels

kV Class	Induced Test 180 or 400 Hz-7200 Cycle	kV BIL		Applied Test 60 Hz (kV)
		Distribution	Power	
1.2	} TWICE RATED VOLTAGE	30	45	10
2.5		45	60	15
5.0		60	75	19
8.7		75	95	26
15.0		95	110	34
25.0 (Grd Y Only)		125	150	40
25.0		150	150	50
34.5 (Grd Y Only)		125	150	50
34.5		150	200	70
46.0		200	250	95

**TABLE 6**  
Temperature Rise Ratings 0 - 3300 feet (0-1000 meters)

	Standard	Optional
Unit Rating	65° C	55/65° C
Ambient Temperature Max.	40° C	40° C
Ambient Temperature 24 Hour Av.	30° C	30° C
Temperature Rise Winding <sup>1</sup>	65° C	55° C
Temperature Rise Hotspot	80° C	65° C

<sup>1</sup> Average Rise by resistance. Refer to NEMA Standards TRI; ANSI Standard C57.12.00.  
Note: Derate kVA by 0.4% for each 100 M (330 ft.) that the altitude is above 1000 M (3300 ft.).

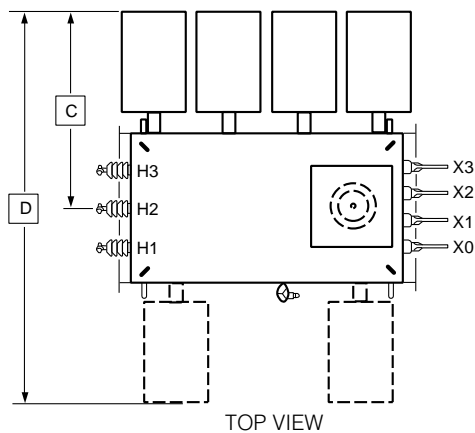

**TABLE 7**  
Oil Filled – Aluminum Windings 55/65°C Rise<sup>1</sup>

kVA	Base Dimensions (in.)		Drawing Dimensions (in.)				Gallons Of Fluid	Approx. Total Weight (lbs.) (With Fluid)
	Width	Depth	A	B	C	D		
500	51	35	69	50	40	59	335	6,300
750	56	36	69	55	36	56	355	7,300
1000	58	36	69	57	42	62	370	8,200
1500	54	36	78	53	54	75	400	9,800
2000	57	38	78	56	55	109	455	12,000
2500	68	40	78	67	50	99	595	14,680
>2500	* Consult Factory Representative							

<sup>1</sup> Weights, gallons of fluid and dimensions are for reference only, and not for construction. Please contact Cooper Power Systems for exact dimensions.

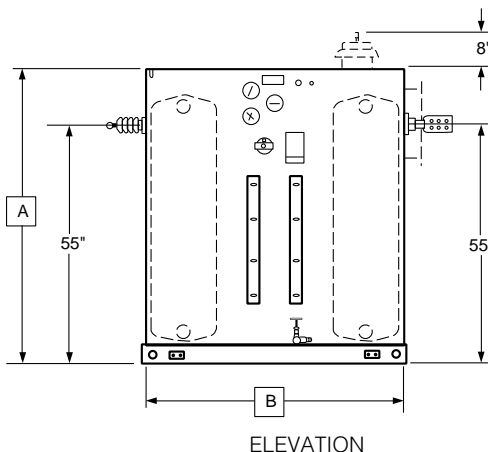
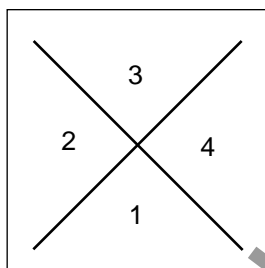

**TABLE 8**  
R-Temp<sup>®</sup> Filled – Aluminum Windings 55/65°C Rise<sup>1</sup>

kVA	Base Dimensions (in.)		Drawing Dimensions (in.)				Gallons Of Fluid	Approx. Total Weight (lbs.) (With Fluid)
	Width	Depth	A	B	C	D		
500	51	35	69	50	40	59	325	6,300
750	56	36	69	55	42	62	355	7,600
1000	58	36	69	57	42	84	375	8,400
1500	56	36	78	55	62	83	425	10,800
2000	60	40	78	59	56	111	530	13,500
2500	68	40	78	67	58	115	620	16,300
>2500	* Consult Factory Representative							

<sup>1</sup> Weights, gallons of fluid and dimensions are for reference only, and not for construction. Please contact Cooper Power Systems for exact dimensions.

**Figure 3.**  
High-voltage left (Segment 2) shown.  
High-voltage right (segment 4) also available.



ANSI segment designation

**TABLE 9**  
Oil Filled – Copper Windings 55/65°C Rise<sup>1</sup>

kVA	Base Dimensions (in.)		Drawing Dimensions (in.)				Gallons Of Fluid	Approx. Total Weight (lbs.) (With Fluid)
	Width	Depth	A	B	C	D		
500	51	34	69	50	39	59	320	5,500
750	55	38	69	54	39	60	375	7,500
1000	59	38	69	58	45	66	390	8,750
1500	51	40	78	50	56	78	435	11,000
2000	59	38	78	58	57	113	475	13,250
2500	59	38	78	58	57	113	500	14,500
>2500	* Consult Factory Representative							

<sup>1</sup> Weights, gallons of fluid and dimensions are for reference only, and not for construction. Please contact Cooper Power Systems for exact dimensions.

**TABLE 10**  
R-Temp<sup>®</sup> Filled – Copper Windings 55/65°C Rise<sup>1</sup>

kVA	Base Dimensions (in.)		Drawing Dimensions (in.)				Gallons Of Fluid	Approx. Total Weight (lbs.) (With Fluid)
	Width	Depth	A	B	C	D		
500	47	34	69	46	39	59	310	5,250
750	55	34	69	54	39	59	350	6,750
1000	55	35	69	54	40	78	350	8,000
1500	59	36	78	58	51	102	450	11,500
2000	59	36	84	58	59	118	510	13,500
2500	63	38	84	62	60	120	550	15,500
>2500	* Consult Factory Representative							

<sup>1</sup> Weights, gallons of fluid and dimensions are for reference only, and not for construction. Please contact Cooper Power Systems for exact dimensions.

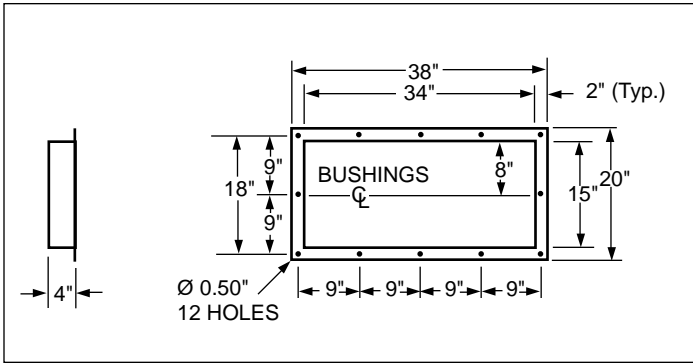

**Figure 4.**  
Throat.

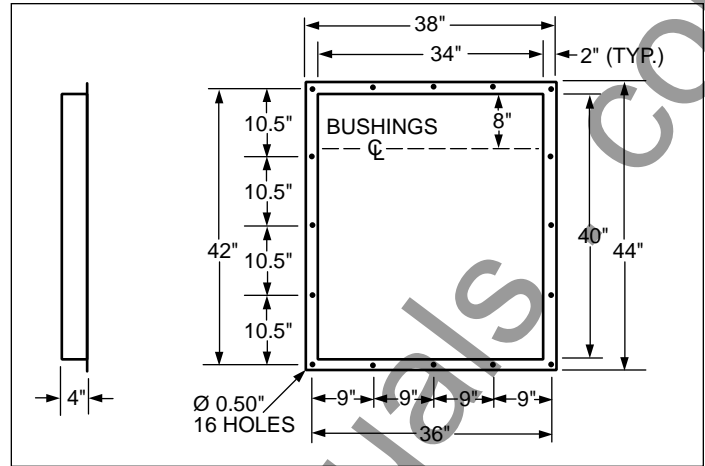

**Figure 7.**  
Flange.

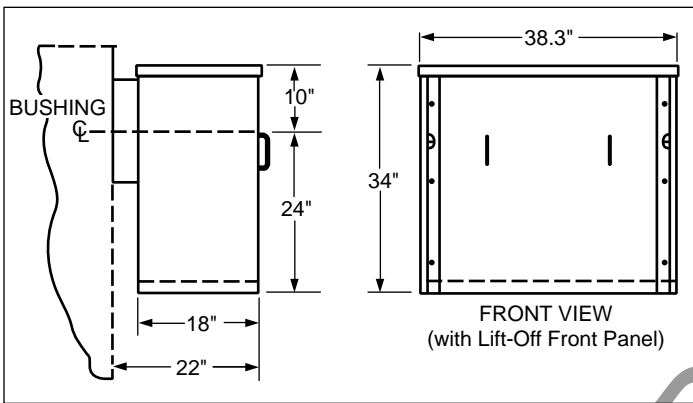

**Figure 5.**  
Air terminal chamber-bottom entry.

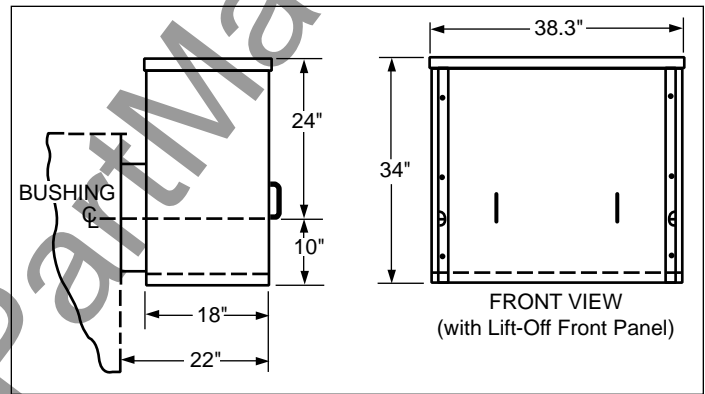

**Figure 8.**  
Air terminal chamber-top entry.

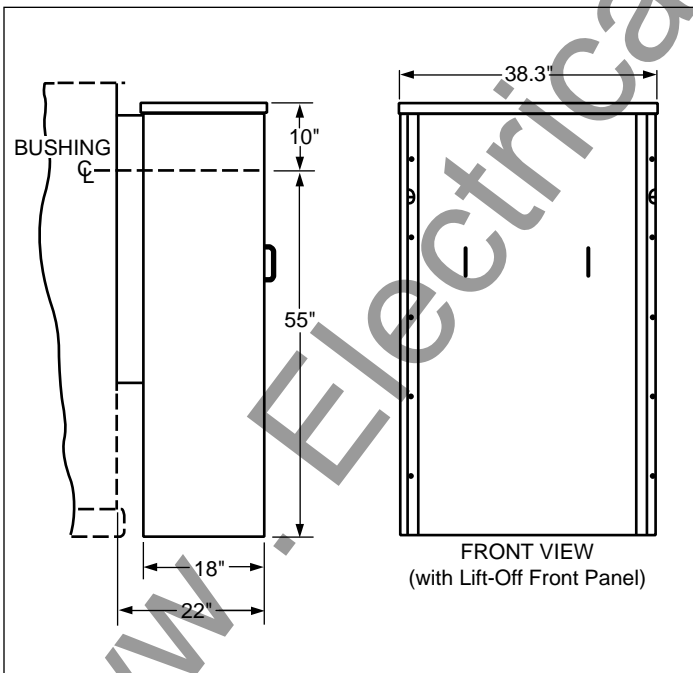

**Figure 6.**  
Full length cabinet-bottom entry.

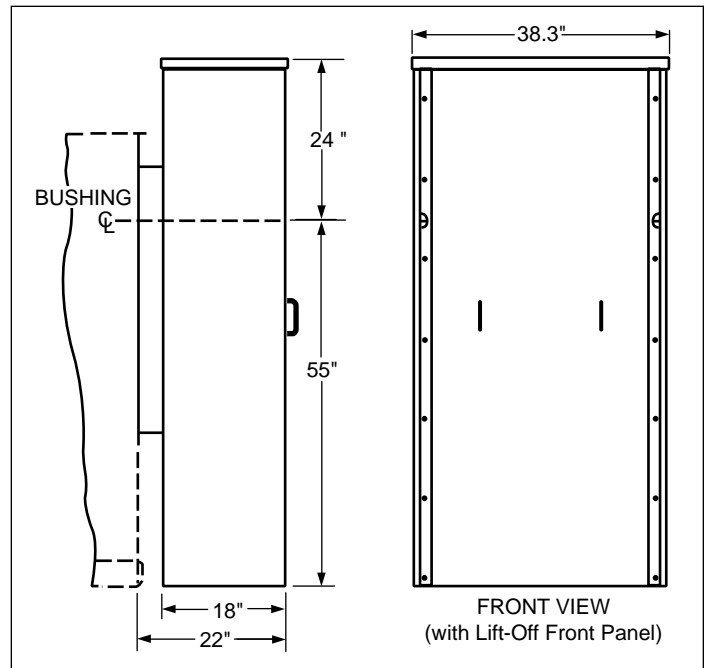

**Figure 9.**  
Full length cabinet-top entry.

## CONSTRUCTION

### Core

The three-legged, step-lap mitered core construction is manufactured using a high-quality cutting machine. For maximum efficiency, cores are precisely stacked, virtually eliminating gaps in the corner joints.

Five-legged wound core or shell-type triplex designs are used for wye-wye connected transformers, and other special transformer designs.

Cores are manufactured with precision cut, burr-free, grain-oriented silicon steel. Many grades of core steel are available for optimizing core loss efficiency.

### Coils

Substation transformers feature a rectangular coil configuration with wire-wound, high-voltage primaries and sheet-wound secondaries. The design minimizes axial stress developed by short circuits and provides for magnetic balancing of tap connections.

Coils are wound using the highest quality winding machines providing exacting tension control and conductor placement for superior short-circuit strength and maximum efficiency.

Extra mechanical strength is provided by diamond pattern, epoxy coated paper insulation, used throughout the coil, with additional epoxy at heavy stress points. The diamond pattern distribution of the epoxy and carefully arranged ducts, provide a network of passages through which cooling fluid can freely circulate.

Coil assemblies are heat-cured under calculated hydraulic pressure to ensure performance against short-circuit forces.

### Core and Coil Assemblies

Substation transformer core and coil assemblies are braced with heavy heavy steel end plates to prevent the rectangular coil from distorting under fault conditions. Plates are clamped in place using presses, and welded or bolted to form a solid core and coil assembly.

### Tanks

Transformer tanks are designed for high strength, and ease of handling, installation, and maintenance. Tanks are welded using precision-cut, hot-rolled, pickled and oiled steel. They are sealed to protect the insulating fluid and other internal components.

Transformer tanks are pressure-tested to withstand 7 psig without permanent distortion and 15 psig without rupture.

### Tank Finish

An advanced multi-stage finishing process exceeds ANSI C57.12.28 standards. The eight-stage pretreatment process assures coating adhesion and retards corrosion. It converts tank surfaces to a nonmetallic, water insoluble iron phosphate coating.

The three-step, epoxy primer (E-coat) provides a barrier against moisture, salt and corrosives. The electrostatically-applied, oven-cured polyester power coat (P-coat) enhances resistance to abrasion and impact. A urethane final coat seals and adds ultraviolet protection.

### Vacuum Processing

Transformers are dried and filled with filtered insulating fluid under vacuum, while secondary windings are energized. Coils are heated to drive out moisture, ensuring maximum penetration of fluid into the coil insulation system. Special attention to moisture removal is the major reason for Cooper's track record of superior reliability and service life.

### Cooling System

Oil-Air (OA) cooling is provided with transformers rated 500 kVA. A choice of OA-FFA (Future Forced Air) or OA-FA (Forced Air) cooling is provided with units rated 750 kVA and above.

### Insulating Fluid

Cooper Power Systems transformers are available with standard electrical grade mineral insulating oil or other dielectric coolants manufactured by Cooper Power Systems. The highly refined oil is tested and degassed to assure a chemically inert product with minimal acid ions. Special additives minimize oxygen absorption and inhibit oxidation. To ensure high dielectric strength, the oil is retested for dryness and dielectric strength, refiltered, heated, dried, and stored under vacuum before being added to the completed transformer. R-Temp fluid, manufactured by Cooper Power Systems under strict quality control for optimum transformer cooling characteristics, provides higher dielectric strength than mineral oil. The special formulation is less flammable as defined by the National Electric Safety Code, as well as non-toxic and biodegradable. Envirotemp® FR3 fluid, the fluid used in Envirotran® transformers is a fire resistant, natural

ester-based fluid. Envirotemp FR3 fluid offers the advantage of a seed oil-based dielectric coolant with food grade additives, in addition to increased fire safety when compared to mineral oil. R-Temp and Envirotemp FR3 fluid can be used in a substation transformer next to buildings or inside buildings with suitable containment provisions.

### SUBSTATION VFI TRANSFORMER

The VFI transformer combines a conventional Cooper Power Systems distribution transformer with the proven Kyle Vacuum Fault Interrupter (VFI). This combination provides both voltage transformation and transformer overcurrent protection in one space saving, money saving package.

The substation VFI transformer with transformer protection protects the transformer and provides proper coordination with upstream protective devices. When a transformer fault or overload condition occurs, the VFI breaker trips and isolates the transformer.

The three-phase VFI breaker has independent single-phase initiation, but is three-phase mechanically gang-tripped. A trip signal on any phase will open all three phases. This feature eliminates single-phasing of three-phase loads. It also enables the VFI breaker to be used as a three-phase loadbreak switch. Because the VFI breaker is resettable, restoring three-phase service is faster and easier.

### R-TRAN™ FM APPROVED TRANSFORMER

Cooper Power Systems' R-Tran Transformer is FM Approved for indoor locations. Factory Mutual Research Corporation's approval of the R-Tran transformer line makes it easy to comply and verify compliance with the 1996 National Electrical Code (NEC®) section 450-23, Less-Flammable Liquid-Filled Transformer Requirements for both indoor and outdoor locations.

FM Approved R-Tran transformers offer the user the benefit of a transformer that can be easily specified to comply with NEC, and makes FM Safety Data Sheet compliance simpler, while also providing maximum safety and flexibility for both indoor and outdoor installations. Because the "FM Approved" logo is readily visible on the transformer and its nameplate, NEC compliance is now easily verifiable by the inspector.

Substation R-Tran FM Approved transformers from Cooper Power Systems are manufactured under strict compliance with FMRC Standard 3990, and are filled with FM Approved R-Temp fire-resistant dielectric coolant.

## Primary Air Disconnect Switch

- Provides economical, visible disconnect primary loadbreak switching.
- Fully coordinated and packaged with the transformer by Cooper Power Systems.
- Meets IEEE/ANSI C37.20.3, NEMA SG-5 and related standards.
- Standard features
  - Switch
    - Three-pole, two-position, gang-operated air interrupter; unfused
    - Standard ratings:
      - 600 A continuous and loadbreak; 40 kA fault close and momentary
      - 5 kV (60 kV BIL) or 15 kV (95 kV BIL)
  - Enclosure
    - Standardized modular self-supporting, bolted design
    - Mechanical safety interlock prevents access when switch is closed or closing of switch when door is open.
- Optional Features
  - 1200 A continuous and load break current rating; 61 kA fault close and momentary. Requires 1200 A copper bus option.
  - Key interlocks (single cylinder) for interlocking primary switch with secondary main circuit protective device.
  - Auxiliary switch for remote indication of primary switch position
  - Where high interrupting ratings and short-circuit protection are desired: current-limiting non-expulsion power fuses
  - Where lower interrupting ratings are adequate:
    - Non-disconnect power fuses
    - Disconnect power fuses

## QUALITY CONTROL

- All transformers are subjected to Routine and Design Performance Tests per the requirements of ANSI C57.12.00
- Each transformer must pass the following tests:
  - Resistance measurements of all windings at the rated voltage connection of each unit, and at the tap extremes.
  - Ratio tests at the rated voltage connection and at all tap connections.
  - Polarity and phase-relation tests at the rated voltage connections.
  - No load losses at rated voltage on the rated voltage connection.
  - Exciting current at rated voltage on the rated voltage connection.
  - Impedance and load loss at rated current on the rated voltage connection of each unit.
- Temperature rise tests
  - Performed in accordance with ANSI Standards.
  - Performed on one unit of a given rating when test records on an essentially duplicate unit are not available.
- Applied potential test
- Induced potential test
- Routine impulse test