

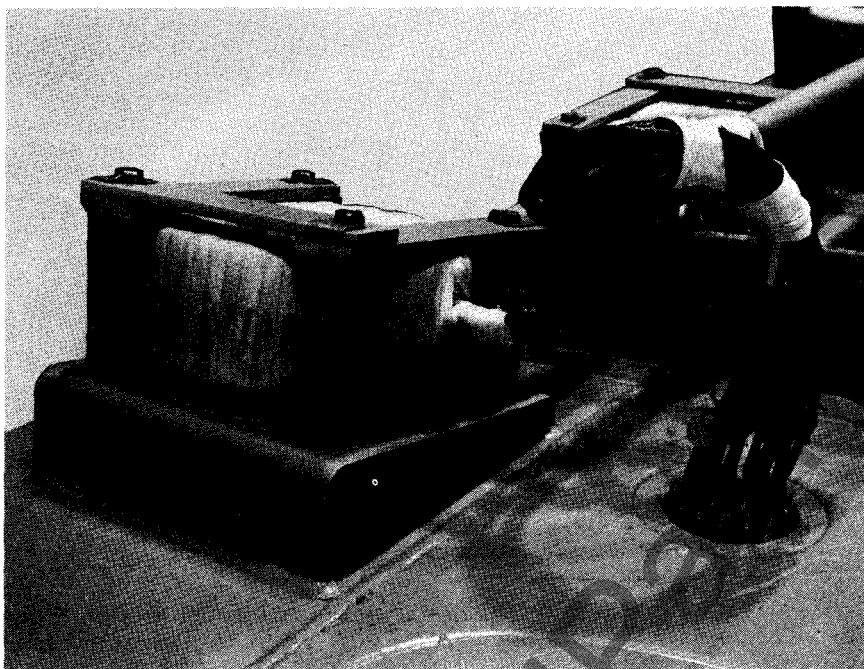

# Current Transformers

## BUSHING AND CABLE TYPES



**Fig. 1. Typical current transformer mounting (viewed with cover upside down)**

### INTRODUCTION

Current transformers (CT's) are employed in power transformers as a source of current for relaying and metering purposes and also in connection with winding temperature equipment and line-drop compensators. They will safely carry a continuous current and a momentary overload equal to that of the equipment in which they were originally furnished.

Current transformers have output currents in proportion to their primary currents and are designed with varying degrees of accuracy, depending upon the application. When furnished for a particular purpose a CT should not be used in some other application without checking its characteristics. Refer to the American Standards Association (ASA C57.13) for an explanation of accuracy classifications for relaying and metering CT's.

### RECEIVING, HANDLING AND STORING

Current transformers are normally shipped completely assembled and ready for service except when ordered as renewal or supply parts. Those mounted in removable bushing adapters are left in the adapter when it is removed for shipment and are to be re-installed with the adapter as an assembly. CT's shipped separately should be examined upon receipt and if injury or rough handling is evident, file a damage claim with the transportation company and notify the nearest Apparatus Sales Office of the General Electric Company.

The crating or boxing used to ship a CT should be removed carefully to avoid damaging the windings. A suggested method of handling is shown in Fig. 2. Care should be taken during handling and storing to keep the transformer flat at all times. Handling in

such a manner as to deform its shape or storing the CT on its round side will usually result in an increase in exciting current. If the CT is to be stored for a period of time, it should be placed in a dry location, out of the weather.

### DESCRIPTION

Two types of CT's are commonly used in power transformers, the bushing-type and the cable-type. The bushing type CT consists of a ribbon-wound core of high-permeability, low-loss silicon steel on which a coil is wound. With the CT mounted around a transformer bushing, this coil serves as the secondary and the bushing conductor becomes a one-turn primary winding. Mounting pads of an insulating material are employed to provide a cushioning effect for mechanical reasons and also for cooling purposes.

Construction of cable-type CT's is identical to that of the bushing-type, except for a smaller opening for the primary. They are usually mounted in



**Fig. 2. Suggested method of handling CT. Place crossbar under spacers when provided**

These instructions do not purport to cover all details or variations in equipment nor to provide for every possible contingency to be met in connection with installation, operation or maintenance. Should further information be desired or should particular problems arise which are not covered sufficiently for the purchaser's purposes, the matter should be referred to the General Electric Company.

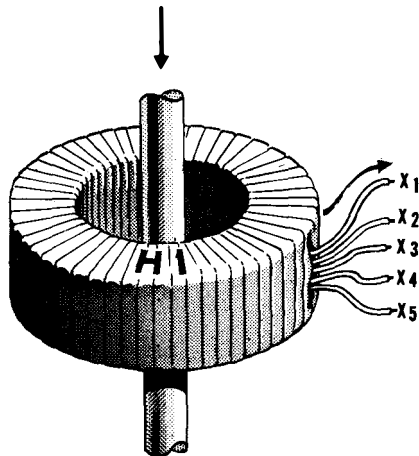

**Fig. 3. CT polarity and lead marking. Arrows show instantaneous direction of current**

the transformer's internal superstructure and use a cable as the primary. In some cases the primary cable is looped around so that it passes through the core window two or more times.

In the case of bushing and cable type CT's, the term "current transformer" normally refers only to the core and its secondary winding. The CT in itself does not provide adequate insulation for full circuit voltage between primary and secondary and therefore depends on the bushing, cable, or other separate material for this insulation.

Secondary windings are of the distributed type, with the turns equally spaced around the circumference of the core. This distribution gives the CT a low leakage reactance, thus maintaining a high degree of accuracy when the transformer is subjected to overload currents. The winding may be tapped to obtain multi-ratio characteristics when required.

The relative instantaneous directions

of primary and secondary currents are subtractive as shown in Fig. 3. The H<sub>1</sub> mark on the secondary coil indicates the polarity of the primary conductor with reference to the secondary terminal. When current in the primary conductor flows toward the H<sub>1</sub> side of the CT, current in the secondary coil flows out from terminal X<sub>1</sub>. With any combination of taps, the tap numerically nearest terminal X<sub>1</sub> has the same polarity as X<sub>1</sub>.

**CT OUTLET**

Secondary leads from relaying and metering CT's are brought out through a low-voltage CT outlet (Fig. 4) which is located on the cover or sidewall of the main transformer. Nameplates inside the outlet cover list the turns ratios for the various taps of each CT and another nameplate on the outside of this cover identifies each lead with respect to its stud number.

The standard CT wiring terminates in this outlet except when the transformer is provided with load-tap-changing equipment or an auxiliary terminal box, in which case two leads from each CT are wired down to these compartments. For shipment, each CT is shorted in the outlet with a jumper and this jumper is not to be removed until the CT is connected to its burden.

**APPLICATION DATA**

The secondary current of a CT will be slightly less than its turns ratio would indicate owing to the error introduced by the exciting current requirements of its core steel. For certain relay applications it may be necessary to determine the extent of this ratio error for a given burden and tap setting at a specified primary current. Typical ratio-correction-factor and excitation curves are available and will be furnished upon request. From these curves it is possible to determine the ratio of the CT with accuracy sufficient

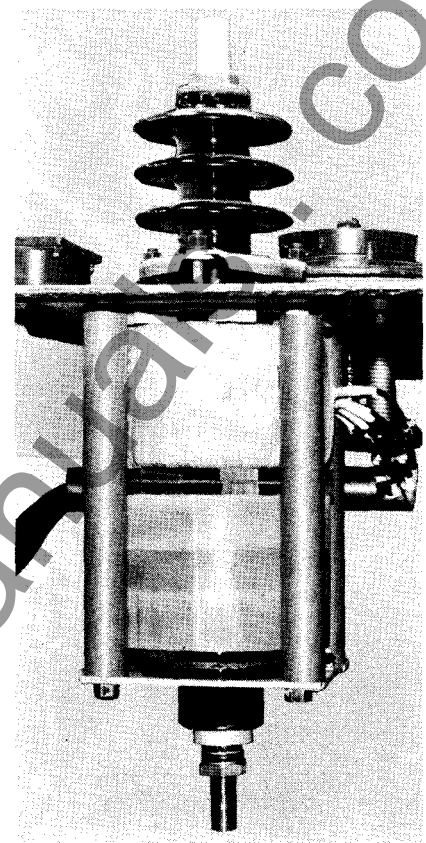

**Fig. 5. Double mounting. Wooden block takes the place of future CT**

for most relay applications (refer to ASA standards C57.13).

For metering applications, CT's can be designed with a slot or opening in the core which permits the use of a compensating winding to correct for ratio and phase-angle errors. This special winding links only a portion of the core and allows the CT to be adjusted to meet a given ASA metering accuracy class on the rated burden. This arrangement thus provides a higher accuracy in the normal operating range than can be obtained with a relaying-type CT of the same physical size. Overcurrent accuracy, however, may be slightly less than with the relaying-type construction. Ratio and phase-angle curves obtained from typical current transformer test data are available upon request.

**INSTALLATION**

All CT's shipped separately should have their condition checked prior to installation. If it is suspected that moisture has entered either during transit or storage, it is recommended that the CT be oven dried for at least 24 hours at a temperature not to exceed 90C. To obtain the proper polarity, the CT must be installed with its H<sub>1</sub> polarity mark

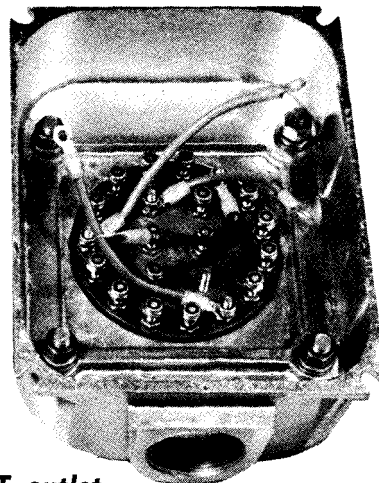
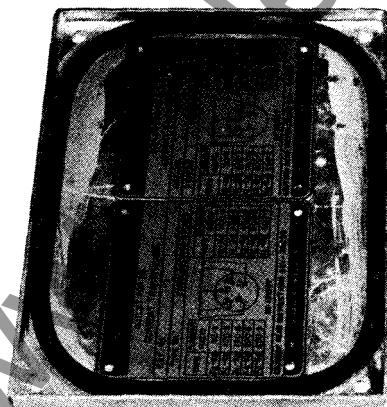

**Fig. 4. CT outlet**

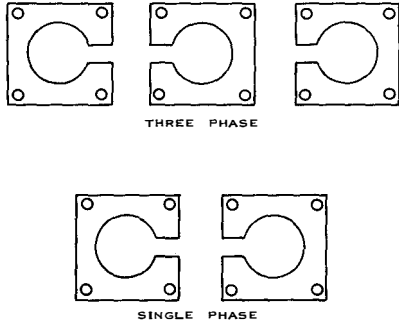

**Fig. 6. Position of slot in supporting plates**

in the correct position as indicated on the main transformer nameplate.

Have all tools and tackle ready before starting the installation so that the work can be performed as quickly as possible. Do not expose the CT or the interior of the main transformer to the atmosphere any longer than necessary. Mounting and wiring details for CT's furnished as supply parts are covered by the Supply Parts Assembly drawing. Note that when two CT's are mounted on a single bushing (Fig. 5) the slots in the supporting plates are to be positioned as shown in Fig. 6. Locking strips are provided for securing the mounting bolts and hardware. Any leads not being used should be insulated so that they will not come in contact with any other leads or grounded parts.

**CONNECTIONS**

**CAUTION:** The secondary circuit of an energized current transformer **MUST NOT** be opened at any time. It must be closed through a load or by the short-circuiting link provided. If the secondary is opened with current flowing in the primary, an excessive peak voltage of many thousands of volts may be developed in the secondary that will present a hazard to operating personnel and can magnetize the core and possibly damage the insulation.

Current transformers removed as part of a bushing adapter assembly have their leads tagged for identification and are to be re-connected at the sleeve-

type disconnect terminals (see Fig. 7). After connecting, these bare terminals are to be insulated with three half-lap wraps of cotton tape followed by an application of G-E A15B15A sticker (air-drying Glyptal®).

All CT secondary windings should be grounded unless doing so will interfere with proper operation of the associated circuit. Where multi-ratio CT's are used and two of its secondary leads are wired down to an auxiliary compartment, it will be necessary for the user to select the desired ratio and make appropriate connections in the CT outlet box in order to complete the external wiring.

In some cases, all of the leads from multi-ratio CT's are wired down to special short-circuiting terminal boards which permit connecting the CT to its load or changing taps while energized. The terminals are provided with knurled set screws which can be inserted through a copper strip to short and/or ground the CT as required. After all connections have been made, remove the shorting screws and store them in the holes provided at each end of the board. Always replace these screws before attempting to remove the burden from the CT.

**MAINTENANCE**

Current transformers generally will not require attention other than occasional inspection to see that all connections are clean and tight and that the leads have not been damaged. However, if it should become necessary to use any of the following procedures while primary current is flowing in a CT, it is again emphasized that great care should be taken in changing burdens or taps to see that the secondary is not accidentally open-circuited.

**EXCITATION TESTS**

The excitation characteristics of the current transformer may be checked, either in or out of the power transformer, by forcing a current of the proper frequency through the primary or secondary. When current is applied through the primary, the developed av-

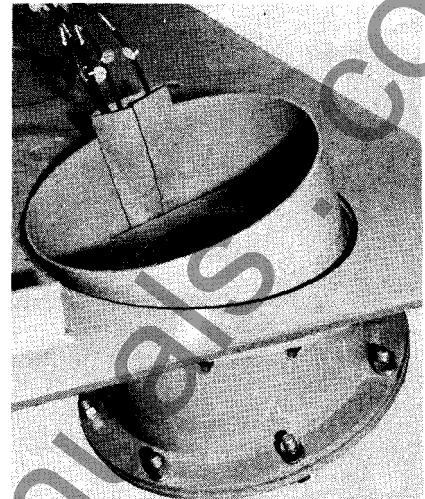

**Fig. 7. CT mounted in removable bushing adapter**

erage voltage can be measured across any two secondary leads as shown in Fig. 8. When energized through the secondary, see Fig. 9, the CT acts like an ideal autotransformer, thus the current can be applied to and the voltage measured from any combination of taps.

This excitation test is an open-circuit test and should be performed without any burden except an averaging type voltmeter connected to the current transformer. An averaging or rectifier type voltmeter such as the DP-2X (which is composed of a d.c. instrument with a rectifier and is calibrated in terms of RMS sine wave voltage) is recommended so that the results obtained will be independent of the harmonics in the applied current or those developed by the CT. The results obtained may be reduced to a common basis or number of secondary turns since both the ampere turns and the volts per turn are constant for any one value of excitation. In making this test, it is always desirable to demagnetize the core beforehand. This is done automatically by checking the excitation at the saturation voltage first and then reducing the current slowly to check the next point without interrupting the circuit and continuing in this manner until the lowest point desired has been

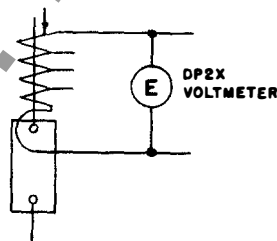

**Fig. 8. Connections for checking excitation characteristics with primary current**

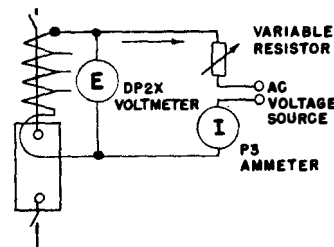

**Fig. 9. Connections for checking excitation characteristics with secondary current**

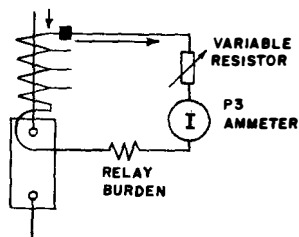

Fig. 10. Connections for demagnetizing with primary current

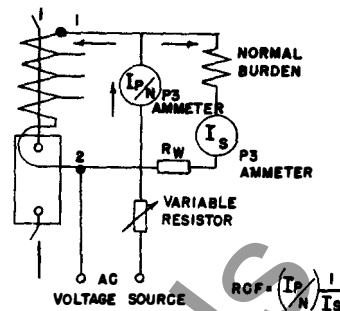

Fig. 11. Connections for checking ratio characteristics with secondary current. See text

taken. It is to be noted that the power transformer must be out of service since the excitation current must be under control. The exciting currents obtained from this test should check within 35 to 50 per cent of the values on the typical curve (available on request or included with the drawings). If the exciting current is very much greater than this, it could indicate a shorted turn which might seriously affect the ratio.

**RATIO TESTS**  
(Except Metering Types)

If it is desired to make a ratio check with a specific burden, this may be performed either by passing primary current through the bushing or cable as in Fig. 10 without the variable resistor or by applying a voltage to the secondary as in Fig. 11 with the primary open-circuited. If the burden is small in magnitude it is advisable to connect a resistance,  $R_W$  (equal to the resistance between points 1 and 2 through the transformer), in series with the burden. The ratio correction factor at a secondary current,  $I_s$ , will be equal to the quotient of the two meter readings as  $RCF = (I_p/N) / I_s$ . The error introduced by the method of Fig. 11 is negligible with resistor  $R_W$  in the circuit. It is preferable to demagnetize the core prior to testing.

**RATIO AND PHASE ANGLE TESTS**  
(Metering Types)

Since the accuracy requirements for metering applications are normally greater than can be obtained from tests using indicating instruments, it is nec-

essary to use accurate measuring techniques such as those listed in ASA standards 57.13-94. Calculation of ratio and phase-angle errors of a current transformer compensated by partial turns from the excitation characteristic is not recommended because the flux density in the core is not a linear function of secondary current. The compensating effect requires the flow of secondary current which is not present when taking an excitation curve.

**INSULATION RESISTANCE**

Checking the current transformer for accidental grounding or low leakage resistance may be most easily performed with either a 500 or 1000 volt "Megger". Short circuit the secondary windings, disconnect all external leads from the terminal boards, and megger the resistance between the secondary winding and station ground. This resistance should have a value in megohms. If the resistance is unusually low the transformer and secondary leads should be inspected for accidental grounding.

**DEMAGNETIZING**

Current transformer cores can acquire a residual magnetism which normally is not removed by load currents. This magnetism may be produced as a result of energizing the primary with the secondary open-circuited or by the application of a high overcurrent, especially if a circuit breaker interrupts a high instantaneous value of current. The bias thus produced will increase the density at which the core operates; therefore, the exciting current increases, affecting the accuracy of the CT. The resulting

error can be neglected in many cases, but where the best accuracy is required any residual magnetism should be removed. This can be done by raising the flux density to the saturation level and then gradually reducing it. Excitation may be obtained with the power transformer either in or out of service.

To demagnetize the core with the unit in service it is only necessary to insert a variable resistance (of suitable wattage) and an ammeter in series with the burden as shown in Fig. 10. The resistance should be increased from zero to such a magnitude that the ammeter reading will fall to at least one-half of its original value. Then gradually reduce the resistance to zero and repeat the process several times. To determine the magnitude of the resistance required, obtain the CT saturation voltage from the excitation curve and divide this figure by one-half of the prevailing secondary current. This quotient can then be adjusted according to the tap being used. Thus, for example, if the saturation level for a particular CT is 100 volts on a given tap and the prevailing secondary current is 5 amps, the required resistance would be  $100/2.5$  or 40 ohms.

To demagnetize the core with the unit out of service, refer to the CT excitation curve and determine the amount of secondary current required to saturate the core. Taking into account the turns ratio or tap being used, gradually apply saturation current to either the primary or secondary with the other winding open-circuited (Figs. 8 and 9) and then slowly reduce it to zero. Repeat several times.

MEDIUM TRANSFORMER DEPARTMENT

**GENERAL ELECTRIC**

ROME, GEORGIA

# INSTRUCTIONS

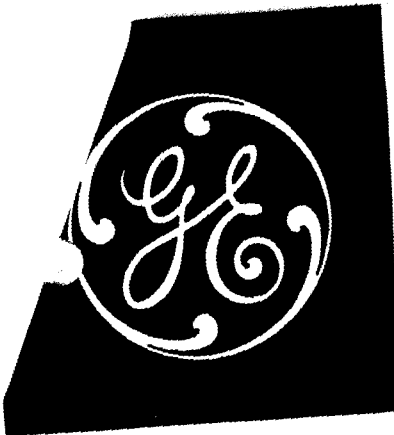

## Current Transformers BUSHING AND CABLE TYPES

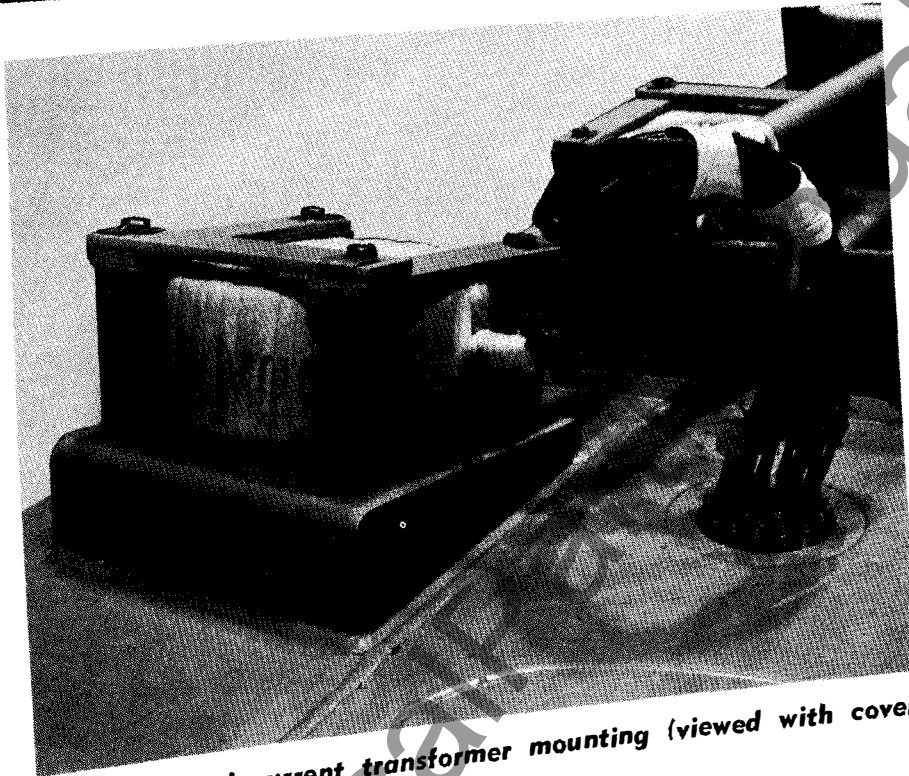

Fig. 1. Typical current transformer mounting (viewed with cover upside down)

### INTRODUCTION

Current transformers (CT's) are employed in power transformers as a source of current for relaying and metering purposes and also in connection with winding temperature equipment and line-drop compensators. They will safely carry a continuous current and a momentary overload equal to that of the equipment in which they were originally furnished.

Current transformers have output currents in proportion to their primary currents and are designed with varying degrees of accuracy, depending upon the application. When furnished for a particular purpose a CT should not be used in some other application without checking its characteristics. Refer to the American Standards Association (ASA C57.13) for an explanation of accuracy classifications for relaying and metering CT's.

### RECEIVING, HANDLING AND STORING

Current transformers are normally shipped completely assembled and ready for service except when ordered as renewal or supply parts. Those mounted in removable bushing adapters are left in the adapter when it is removed for shipment and are to be re-installed with the adapter as an assembly. CT's shipped separately should be examined upon receipt and if injury or rough handling is evident, file a damage claim with the transportation company and notify the nearest Apparatus Sales Office of the General Electric Company.

The crating or boxing used to ship a CT should be removed carefully to avoid damaging the windings. A suggested method of handling is shown in Fig. 2. Care should be taken during handling and storing to keep the transformer flat at all times. Handling in

such a manner as to deform its shape or storing the CT on its round side will usually result in an increase in exciting current. If the CT is to be stored for a period of time, it should be placed in a dry location, out of the weather.

### DESCRIPTION

Two types of CT's are commonly used in power transformers, the bushing-type and the cable-type. The bushing type CT consists of a ribbon-wound core of high-permeability, low-loss silicon steel on which a coil is wound. With the CT mounted around a transformer bushing, this coil serves as the secondary and the bushing conductor becomes a one-turn primary winding. Mounting pads of an insulating material are employed to provide a cushioning effect for mechanical reasons and also for cooling purposes.

Construction of cable-type CT's identical to that of the bushing-type except for a smaller opening for the primary. They are usually mounted



Fig. 2. Suggested method of handling and storing

These instructions do not purport to cover all details or variations in equipment nor to provide for every particular with installation, operation or maintenance. Should further information be desired or should particular questions for the purchaser's purposes, the matter should be referred to the General Electric Company.

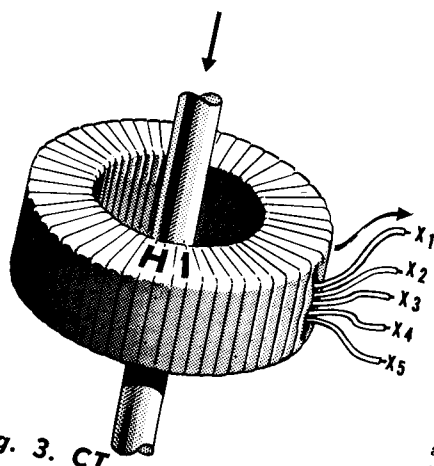

Fig. 3. CT polarity and lead marking. Arrows show instantaneous direction of current

of primary and secondary currents are subtractive as shown in Fig. 3. The H<sub>1</sub> mark on the secondary coil indicates the polarity of the primary conductor with reference to the secondary terminal. When current in the primary conductor flows toward the H<sub>1</sub> side of the CT, current in the secondary coil flows out from terminal X<sub>1</sub>. With any combination of taps, the tap numerically nearest terminal X<sub>1</sub> has the same polarity as X<sub>1</sub>.

CT OUTLET

Secondary leads from relaying CT's are brought a low-voltage CT outlet is located on the cover side the outlet cover for the various another name this cover respect to

the transformer's internal superstructure and use a cable as the primary. In some cases the primary cable is looped around so that it passes through the core window two or more times. In the case of bushing and cable CT's, the term "current transformer" normally refers only to the secondary winding. The does not provide adequate secondary and the bushing, cable, material for this :

Second  
tribut  
pace.  
ore. 1.  
w leaka  
high deg.  
nsformer is  
ents. The win  
in multi-ratio  
red.  
relative instantan

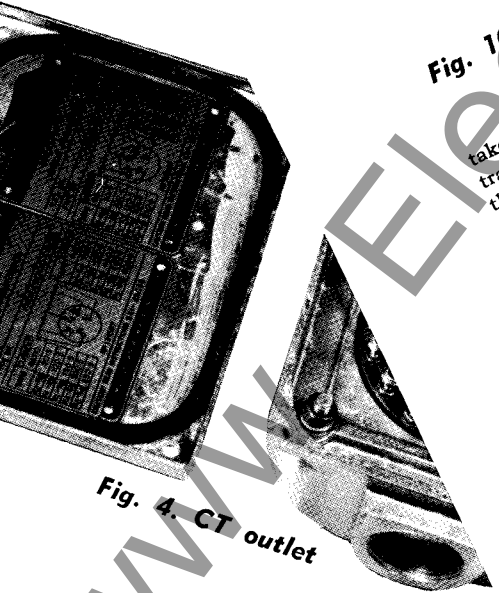

Fig. 4. CT outlet

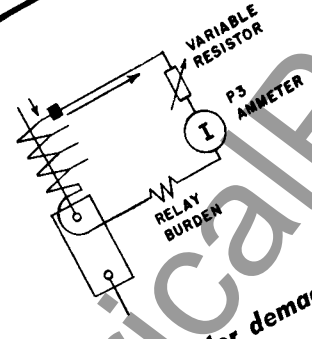

Fig. 10. Connections for demagnetizing with primary current

It is to be noted that the power transformer must be out of service since the exciting current must be under control. The exciting current obtained from this test should check within 5 to 50 per cent of the values on the typical curve (available on request included with the drawings). If the exciting current is very much greater than this, it could indicate a shorted turn which might seriously affect the ratio.

RATIO TESTS  
(Except Metering Types)

If it is desired to make a ratio check with a specific burden, this may be performed either by passing primary current through the bushing or cable as in Fig. 10 without the variable resistor or by applying a voltage to the secondary as in Fig. 11 with the burden short-circuited. If the burden is small in magnitude it is advisable to connect a resistance, R<sub>w</sub> (equal to the resistance between points 1 and 2 through the transformer), in series with the burden. The correction factor at a secondary readings will be equal to the quotient of the error introduced as

INSULATION RESISTANCE

Checking the current transformer for accidental grounding or low leakage resistance may be most easily performed with either a 500 or 1000 volt "Megger". Short circuit the secondary windings, disconnect all external leads from the terminal boards, and megger the resistance between the secondary winding and station ground. This resistance should have a value in megohms. If the resistance is unusually low the transformer and secondary leads should be inspected for accidental grounding.

DEMAGNETIZING

Current transformer cores can acquire a residual magnetism which normally is not removed by load currents. This magnetism may be produced as a result of the primary with the secondary short-circuited or by the application of a high current. The

Fig. 11. Connections for checking ratio characteristics with secondary current. See text

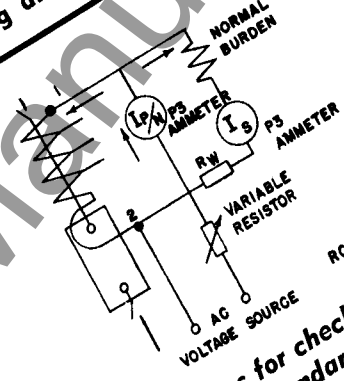

Current Transformers, Bushing and Cable Types GEI-65093

