

SECONDARY UNIT SUBSTATIONS

RATINGS: ALL STANDARD KVA RATINGS ■ PRIMARY: 2.4 THROUGH 13.8KV
■ SECONDARY: 208/120 THROUGH 600 VOLTS ■ INDOOR OR OUTDOOR ■ WITH OIL OR ASKAREL-IMMERSED, VENTILATED OR SEALED-DRY TRANSFORMERS.

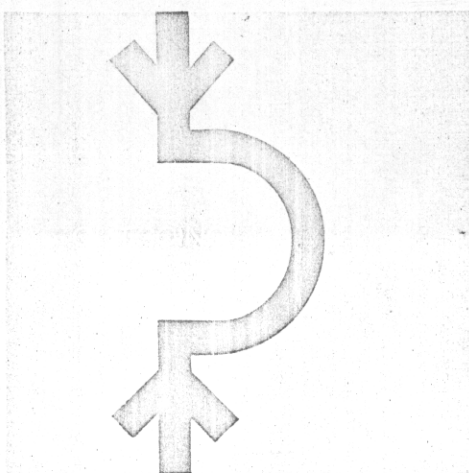

*Issue Date
Jan 65*

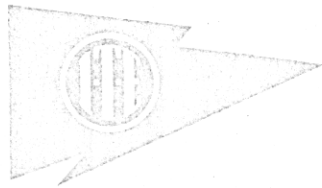

CONSIDER THESE

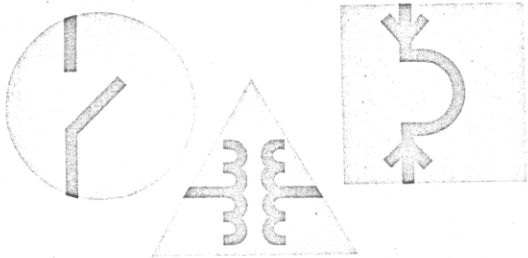

PRIME ADVANTAGES BEFORE YOU PURCHASE ANY ELECTRICAL DISTRIBUTION EQUIPMENT

INCREASED SAFETY

Personnel and equipment are protected at all times. All live parts are insulated and the entire structure is completely metal enclosed. No fences or rails are necessary.

CONTINUITY OF SERVICE

No lost time replacing component parts. Overloads and faults will affect only a small portion of the system. The affected breaker can be reset in seconds.

COORDINATED ENGINEERING

Application and engineering of all components are completely coordinated by I-T-E under one roof. No loose ends for purchaser to tie together. All components are manufactured in one plant and shipped at one time.

SPACE SAVING

Neat, compact, functionally-designed units requiring much less space than separately-connected individual assemblies. They may be installed anywhere—indoors, outdoors, on balconies, in basements, etc.

LOWER COSTS

Economical initial investment together with reduced power costs by bringing high voltages direct to load areas. This also effects greater savings in conductor costs.

FUTURE EXPANSION

Future expansion may be accomplished by two means. The secondary switchgear may have blank or future compartments built right in. Also, additional structures may be added at the ends that will completely match and line up with the original installation.

PROMPT DELIVERY

One order, completely coordinated from one supplier is assembled, tested and shipped as a unit ready for immediate installation.

MORE EFFICIENT

Better voltage regulation for machinery and lighting by reduction of voltage drops inherent in long low voltage cable runs.

EASY INSTALLATION

Simplified sections or parts are easily assembled in the desired location according to your floor plan. Final connections to the primary and the secondary leads complete the job.

COMPLETE FLEXIBILITY

Great variety of primary devices, transformers and secondary switchgear permits adaptability to any application.

LITTLE MAINTENANCE

Once installed, an I-T-E substation requires little or no maintenance to give years of trouble-free service.

BUILDING-BLOCK SUBSTATION DESIGN ALLOWS YOU TO SELECT THE RIGHT COMPONENTS TO FIT YOUR EXACT REQUIREMENTS

1. SELECT THE SYSTEM

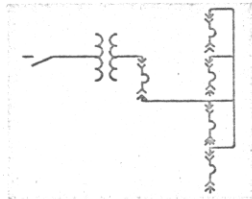

RADIAL

This type has a single incoming primary device, a single transformer and an outgoing section of one or more low-voltage power circuit breaker feeders.

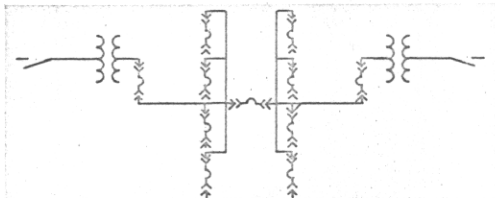

SECONDARY SELECTIVE

This type has two incoming primary devices and two transformers, each connected to their own outgoing section of one or more low-voltage power circuit breaker feeders. These breakers are joined by a bus which contains a normally-open tie breaker.

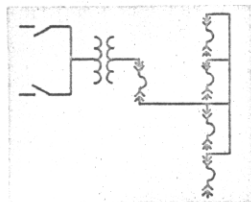

PRIMARY SELECTIVE

This type contains two primary sources (one or more devices), a single transformer and an outgoing section of one or more low-voltage power circuit breaker feeders.

2. SELECT THE COMPONENTS

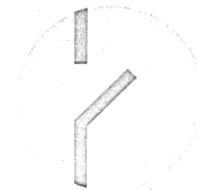

PRIMARY DEVICES—INCOMING

- AIR INTERRUPTER SWITCH (FUSED OR UNFUSED)
- AIR INTERRUPTER SELECTOR SWITCH (FUSED OR UNFUSED)
- AIR TERMINAL CHAMBER
- LIQUID INTERRUPTER OR DISCONNECT SWITCH
- OIL CUTOUPS (FUSED OR UNFUSED)
- METAL-CLAD SWITCHGEAR

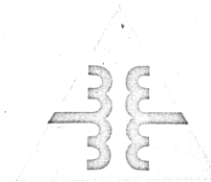

TRANSFORMERS

- LIQUID-IMMERSED (ASKAREL)
- LIQUID-IMMERSED (OIL)
- VENTILATED-DRY
- SEALED-DRY, GAS

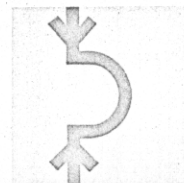

SECONDARY DEVICES—OUTGOING

- LOW-VOLTAGE POWER CIRCUIT BREAKERS
- FUSED LOW-VOLTAGE POWER CIRCUIT BREAKERS

TABLE OF CONTENTS

	Page No.
BUILDING BLOCK CONSTRUCTION.....	3
DESCRIPTION	
INCOMING LINE SECTION	4
TRANSFORMER SECTION	6
OUTGOING SECTION	14
DIMENSIONS AND WEIGHTS	
INCOMING SECTION	24
TRANSFORMER SECTION	25
OUTGOING SECTION	25
WEIGHTS	27
APPLICATION INFORMATION	
INCOMING SECTION	28
TRANSFORMER SECTION	29
OUTGOING SECTION	30
GUIDE SPECIFICATIONS.....	36

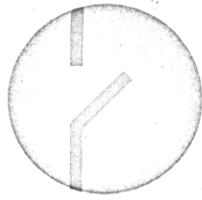

Incoming Line Section



1. AIR INTERRUPTER SWITCH— FUSED OR UNFUSED

The I-T-E type HPL-C air interrupter switch is a 3-pole, 2-position device which utilizes a snap-action quick-make, quick-break blade in combination with an arc chute for safe closing and interruption. Visual indication thru the safety glass front window and on the handle mechanism shows the blade position.

Fused switches are interlocked to prevent opening of the fuse door while the switch is in the closed position. I-T-E type CL current-limiting fuses are used.

The switches are available with or without lightning arresters, can be equipped with cable lugs or potheads and can be entered from top or bottom.

Duplex switches are available, consisting of two key-interlocked switches located side by side.

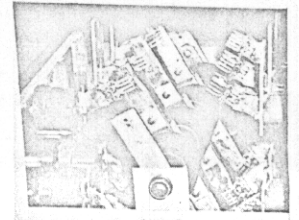
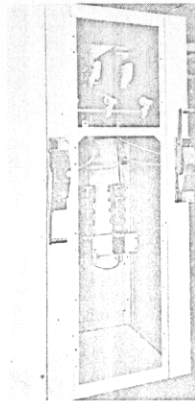
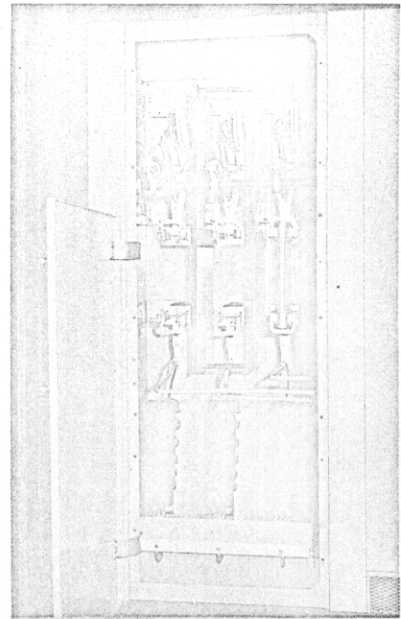

Cutaway of 3-pole selector switch shows blade positions for connection of one incoming line.

Air Interrupter Selector Switch consists of a rear mounted 3 pole, 2-position selector device in series and interlocked with the interrupter switch. An interlock prevents switching of lines while under load. It has a front mounted handle mechanism which visually indicates Line 1 or Line 2.

2. AIR TERMINAL CHAMBERS

Full-height floor-mounted air terminal chambers equipped with cable lugs or potheads are directly connected to the transformer. Top or bottom entrance and indoor or outdoor construction are available.

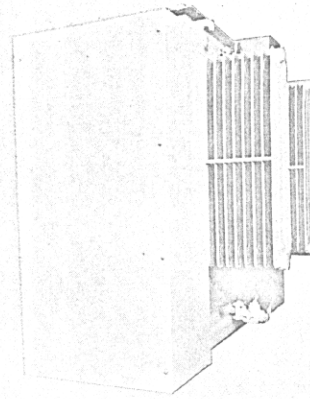

3. LIQUID INTERRUPTER OR DISCONNECT SWITCH

These devices can be provided on liquid-immersed transformers only. They are three-pole, two- or three-position units. The switch enclosure is welded or bolted to the transformer tank. When oil filled, they are interrupter switches that can interrupt load currents up to 400 amperes. When askarel filled, they have no interrupting capacity but can be used as disconnect switch to break magnetizing currents up to 10 amperes five times, after which the askarel must be changed. Potheads are always provided. Liquid is shipped in separate container to avoid draining the switch to make cable connections.

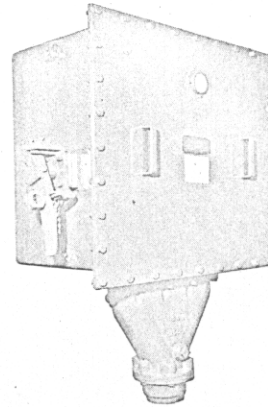

4. OIL CUTOUTS—FUSED OR UNFUSED

Oil cutouts are supplied mounted in a terminal chamber and have provisions for terminating one 3-phase feeder cable. They may be used within rating limits of 300 kva at 2400 volts and 500 kva at 4160 volts. They can also be used unfused as disconnects up to 750 kva at 2400 volts or 1000 kva at 4160 volts. Values are based on applying fuses at twice the full-load current rating of the transformer. Available for indoor or outdoor installation.

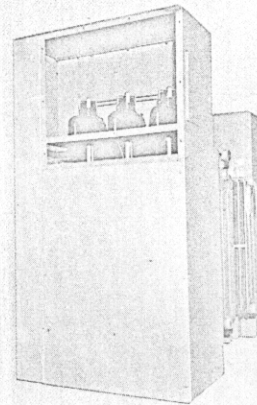

5. METAL-CLAD SWITCHGEAR

For the ultimate in primary protection, type HK metal-clad switchgear with stored-energy air-magnetic power circuit breakers is available. They are drawout elements mounted in full-height compartments complete with all standard accessories.

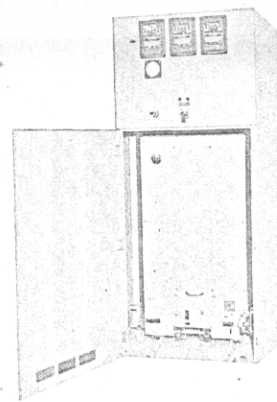

For complete information on metal-clad switchgear see I-T-E Bulletin 2800-2B.



Compare these features with other transformer designs →

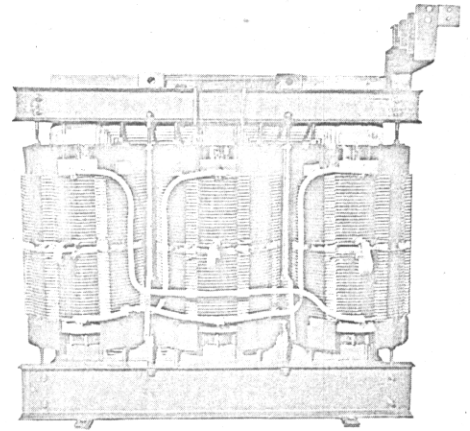

VENTILATED-DRY

- ☐ Moisture-resistant insulating materials
- ☐ Low sound levels
- ☐ Reduced size and weight
- ☐ Increased impulse and dielectric level
- ☐ Logical-sequence-assembly enclosure

TRANSFORMER SECTION

TABLE 1. STANDARD TRANSFORMER RATINGS*

TYPE	KVA 3-Phase Self Cooled	KVA 3-Phase Forced Air Cooled	Primary Voltage Delta	SECONDARY VOLTAGE		
				208Y/120 240 delta	480Y/227 480 delta	
Liquid- Immersed Oil Askarel 65 C Rise	112½	—	} 2400 4160 4800 6900 7200 12000 13200 13800	X	X	
	150	—		X	X	
	225	—		X	X	
	300	—		X	X	
	500	—		X	X	
	750	862		X	X	
	1000	1150		X	X	
	1500	1725			X	
	2000	2300			X	
	2500	2875			X	
Vent-Dry 150 C Rise	112½	—	} 2400 4160 4800	X	X	
	150	—		X	X	
	225	—		X	X	
	300	—		X	X	
	500	—		} 2400 4160 4800 6900 7200 12000 13200 13800	X	X
	750	1000			X	X
	1000	1333			X	X
	1500	2000				X
	2000	2666				X
	2500	3333				X
Sealed-Dry Gas Filled 150 C Rise	300		} 2400 4160 4800 6900 7200 12000 13200 13800	X	X	
	500			X	X	
	750			X	X	
	1000			X	X	
	1500				X	
	2000				X	
	2500				X	

55 C or 55/65 C rise liquid-immersed oil or askarel, 80 C rise ventilated-dry type and 150 C nitrogen-filled sealed-dry type transformers are available as non-standard. For information consult your nearest I-T-E District Office.

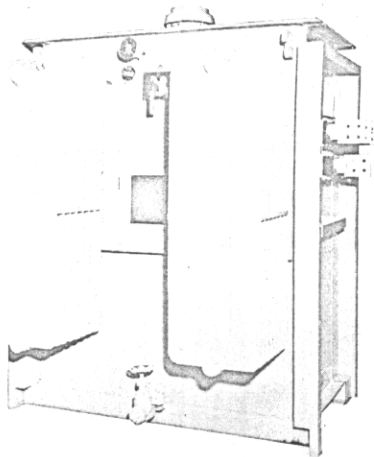

INDOOR (ASKAREL)

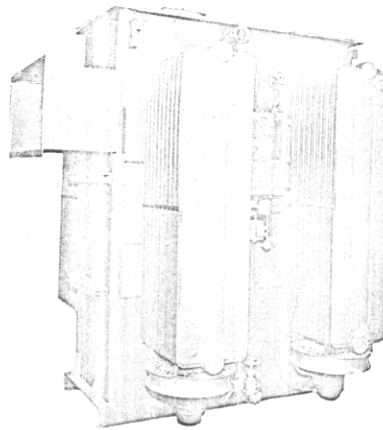

OUTDOOR (OIL)

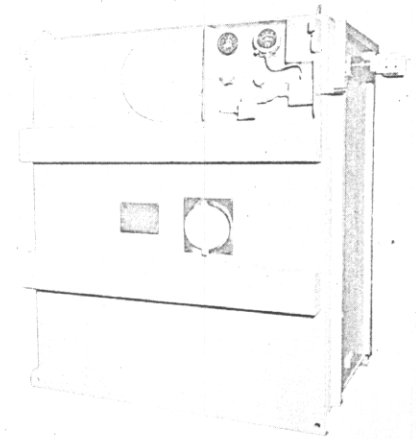

SEALED-DRY

LIQUID-IMMERSED

- ☐ 25%—Lighter weight
- ☐ 25%—Less floor space
- ☐ 10%—Lower height
- ☐ New radiator design
- ☐ New insulation system

- ☐ Fluorocarbon gas
- ☐ Higher dielectric
- ☐ Higher impulse levels
- ☐ Faster heat transfer
- ☐ Lighter weight
- ☐ More compact

TABLE 2. COMPARISON OF CHARACTERISTICS OF LIQUID-IMMERSED AND DRY-TYPE TRANSFORMERS

1500 KVA, 15 KV to 480 volts, Oil-immersed transformer as base.

CHARACTERISTICS	LIQUID-IMMERSED 65 C		VENTILATED-DRY 150 C	SEALED-DRY 150 C
	OIL	ASKAREL		GAS (C ₂ F ₆)
Insulation Type	Class A	Class A	Class H	Class H
Impulse Strength	110 kv	110 kv	65 kv	95 kv
Losses @ 75 C: No Load Full Load	100% 100%	100% 100%	155% 117%	155% 100%
Maximum Voltage Class	15 kv	15 kv	15 kv	15 kv
Temperature Ratings: Average Rise, C Hottest Spot Rise, C	65 80	65 80	150 180	150 180
Sound Level	100%	100%	108%	106%
Weights	100%	120%	80%	100%
Dimensions: Floor Space Height	100% 100%	100% 105%	130% 103%	120% 103%
Application: Indoor, Outdoor	Indoor (vault only) Outdoor	Indoor Outdoor	Indoor	Indoor Outdoor †
Fire, Explosion, and Toxic Resistant	No	No	Yes	Yes
Maintenance: Liquid Cleaning (Internal) (External)	Yes No Normal	Yes No Normal	No Yes Occasionally	No No Minimum
Precautions before energizing after shutdown to dry insulation	None	None	None	None

Note: Values stated are approximate average and subject to variation with KVA size, KV rating, etc.

†Applicable for all types of installations assuming no exposure to lightning, and assuming adequate protection against impulse voltage.

STANDARD ELECTRICAL TESTS

- Winding-resistance test
- Ratio test
- Polarity and phase-relation test
- No-load loss test
- Exciting current test
- Impedance and load loss test
- Applied potential test
- Induced potential test

STANDARD ACCESSORIES ON UNIT SUBSTATION TRANSFORMERS:

LIQUID-IMMERSED TRANSFORMERS (ALL KVA RATINGS)

- Magnetic liquid-level gauge
- Thermometer in closed well with maximum indicating hand
- Pressure-vacuum gauge
- Pressure-vacuum bleeder
- Pressure-relief device (askarel only)
- Combination drain valve, lower-filter connection and sampling valve
- Upper-filter connection
- Sampling device at top-liquid level (askarel only)
- Skid base with jacking and towing provisions
- Transformer lifting hooks
- Cover lifting eyes
- Ground pad located on LV end
- No load, externally-operated tap changer
- 1-inch vent plug in cover

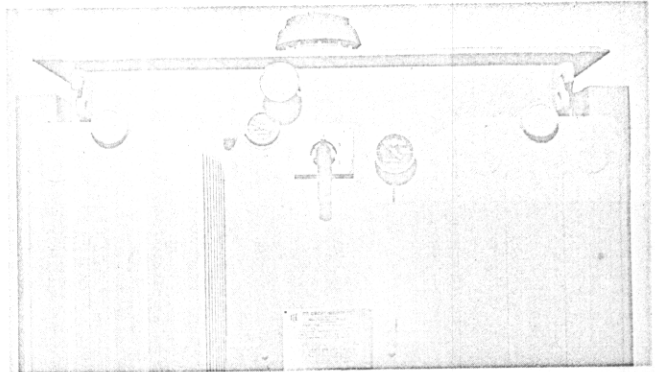

- Hand-hole in cover
- Diagrammatic nameplate
- Sealed tank with welded cover

VENTILATED-DRY TRANSFORMERS (ALL KVA RATINGS)

- Skid base with provision for jacking or towing
- Flexible links for changing taps
- Ground pad
- Lifting eyes on upper core clamp
- Diagrammatic nameplate

SEALED DRY TRANSFORMERS

- Pressure test and filling valve
- High-low pressure-alarm device with contacts
- Pressure-vacuum gauge
- No-load externally-operated tap changer
- Ground pad on LV side
- Skid base with provision for jacking and towing
- Transformer lifting hooks
- Cover lifting eye
- Hermetically-sealed bushings
- Diagrammatic nameplate
- Pressure relief valve

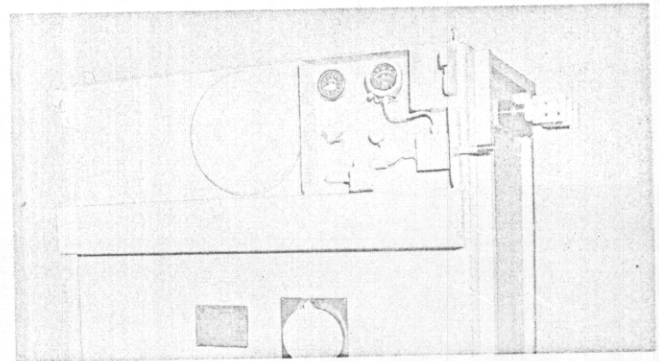

OPTIONAL ACCESSORIES ARE AVAILABLE AS FOLLOWS:

- Winding temperature equipment
- Gas absorbers for askarel filled transformers
- Tap changer interlocks

FAN PROVISIONS:

All liquid-filled and ventilated-dry transformers, 750 KVA and above have provision for the future addition of cooling fans.

This provision for forced air cooling will include:

1. Capacity in all current-carrying parts, including bushings for the forced-cooled rating.
2. Provision for mounting in the field, the balance of the equipment required.
3. Provision for the future automatic control of the fans as follows:
 - a. Liquid-filled units—provision for incorporating the thermometer relay for control of the future fans from top liquid temperature.
 - b. Ventilating-dry units—provision only for mounting winding-temperature relay for control of future fans from winding temperature.

DETAILS OF CONSTRUCTION

CORE

The core of each transformer is made of non-aging, high permeability, grain-oriented, cold-rolled, silicon steel specifically processed for consistently low losses.

The thin-gauge laminations are sheared with special high quality shear blades in such a manner that the flux path will be aligned with the axis of highest permeability in the steel. Each lamination is flat and free from burrs and is inorganically insulated on both surfaces to minimize eddy-current loss.

Laminations are hand stacked on a specially designed table which ensures flatness and prevents the introduction of bending stresses while the finished core is being set in an upright position. Careful positioning of each lamination produces close fitting lap and butt joints to further minimize core loss and noise.

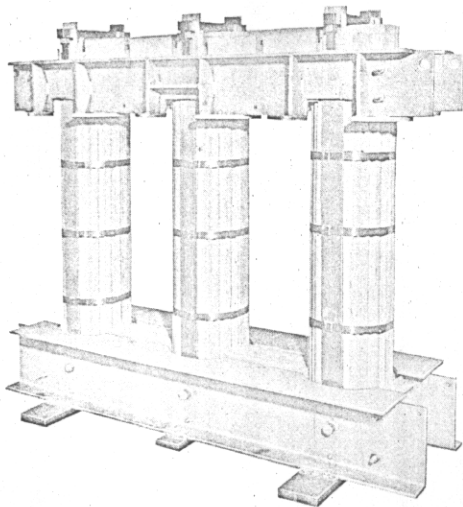

Core legs are assemblies of laminations of various widths, thereby approximating circular cross sections to accommodate the coils with the optimum combination of high space factor and coolant flow.

The upper and lower core yokes are rigidly clamped by welded assemblies of structural steel members consistent with bracing and supporting requirements. Core clamps are steel grit blasted to remove mill scale and slag and to assure that only clean, bright metal will be in contact with the cooling liquid. On ventilated-dry type transformers, the entire core assembly is painted to insure against oxidation. Core clamps and all structural parts are insulated to prevent local circulating currents and are solidly bonded to ground and to the core to prevent development of potential in any part.

I-T-E regards the coils as the most important part of the transformer. No fixed rules are followed for their construction. They may be barrel helical, disk or sheet wound depending on rating, current and voltage. Regardless of the construction used, the following requirements must be met:

1. **STRESSES:** Primary and secondary coils must be concentric to eliminate interaction of forces caused by short-circuit stresses. I-T-E coils are, therefore, wound with the secondary coil nearest the core and supported by a strong insulating cylinder. The primary coil is then wound on top of the secondary coil. A suitable insulating full-length barrier is provided between the two coils, consisting of spacers and sheet insulation built up to the proper thickness. The coil wire is wound tightly and uniformly thru a tension device to insure maximum strength.
2. **COOLING:** The coils must be equipped with cooling channels in order to dissipate the heat generated in the coils. This is accomplished by insertion of spacer sticks at suitable intervals between the layers of the coil.

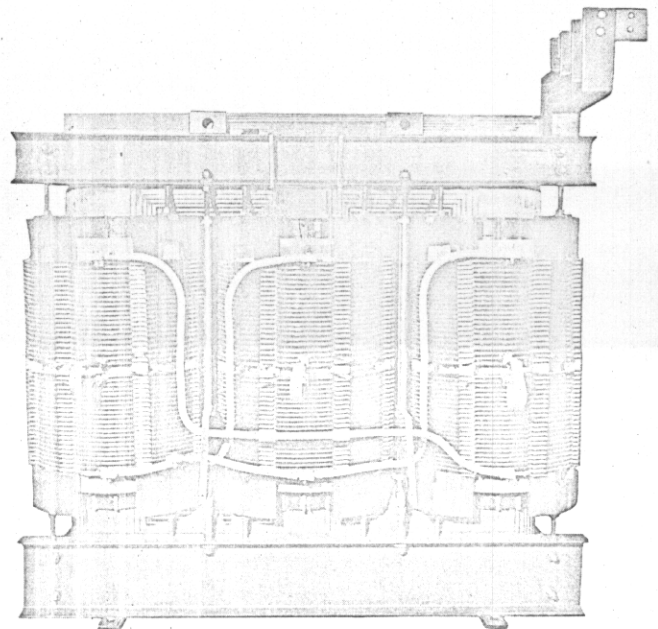

Core and Coils—Ventilated Dry Type

3. **CURRENT CARRYING ABILITY:** The current density in the individual strands of the coil must not be greater than permitted by the proper cooling of the coil. Heavy current coils are made of multi-conductors properly transposed to minimize eddy currents and to obtain equal current distribution in the conductor.

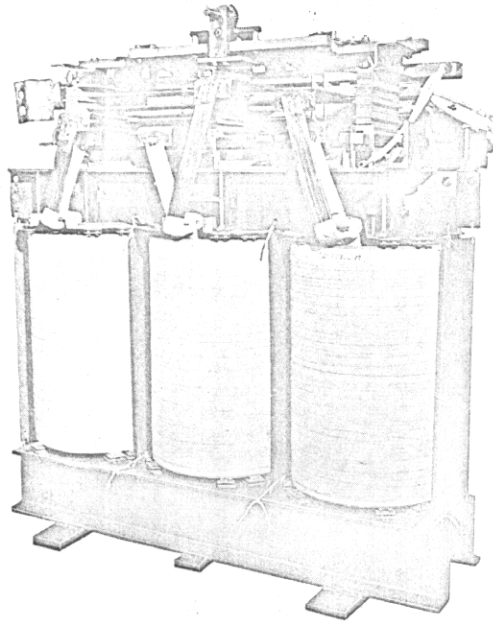

Core and Coils—Liquid-Immersed Type

4. **CONDUCTORS:** I-T-E coils are wound from continuous wires to eliminate joints; taps are silver brazed to the coils at the proper locations.

10

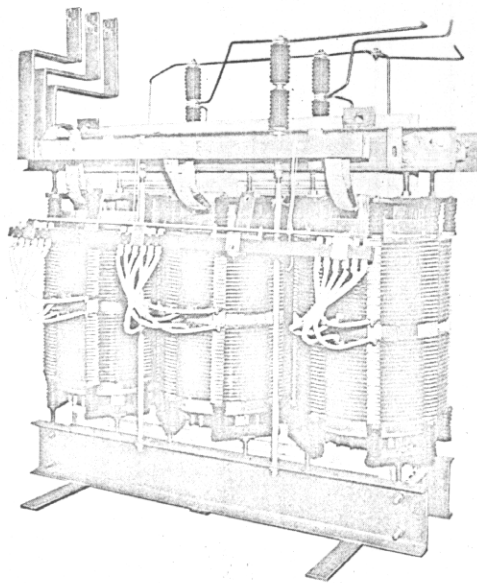

Core and Coils—Sealed-Dry Type

INSULATING MATERIAL

All insulating materials used have been thoroughly tested and proven with respect to their electrical and mechanical characteristics and are stable at operating temperatures and compatible with the cooling medium.

In liquid-filled transformers, the insulation system is thermally upgraded. It is chemically modified to resist the effects of high temperature. The improved insulation enables the new, compact transformers to maintain full load-carrying ability at their higher operating temperature without affecting life expectancy.

Thermally-upgraded pressboard insulation is used for coil spacers, both longitudinal and radial, as well as ends. It is also used between layers and between high and low-voltage coils. The porosity of the insulating materials permits the insulating liquid to penetrate the insulating materials giving it a high dielectric strength.

The figure below compares the absolute value of toughness, measured in inch-pounds, of thermally-upgraded insulation and untreated electrical-grade kraft.

As shown by the curve, the initial toughness of the new insulation after drying and oil impregnating is 97% higher than that of electrical-grade kraft, and a substantial improvement in toughness is maintained during aging at 150 C.

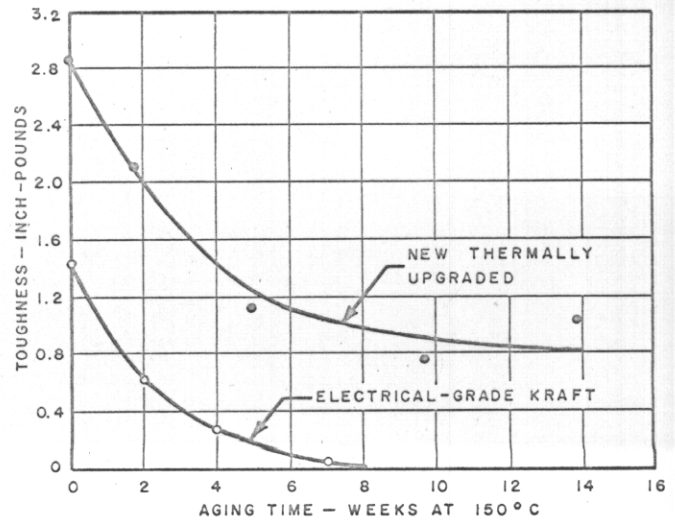

Figure 1—Comparison of absolute values for toughness of new thermally-upgraded insulation vs electrical-grade kraft.

TRANSFORMER SUPERSTRUCTURE

The superstructure consists of the secondary bus bars with their associated connections to the secondary coil leads, the tap changer and the supporting channels for the primary leads. Secondary bus bars are held in alignment by pressboard spacers. Non-magnetic through-

IMMERSED TRANSFORMERS

bolts in an insulating tube bind the spacers securely together. The primary leads are supported in pressboard channels.

The complete superstructure is pre-assembled and installed on the transformer.

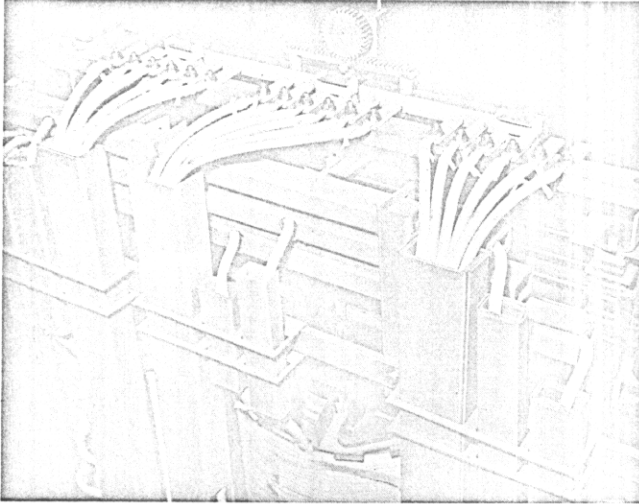

TAP CHANGER

The tap changer is the in-line type, consisting of an insulated bar on which are mounted three-sets of six stationary contacts. Bridging two stationary contacts of each set are two self-aligning spring-loaded movable contacts. The movable contacts are driven by a common insulated bar by means of a gear train thru an externally-operated tap-changer handle.

DRYING OF CORE AND COIL

An important step in the manufacturing process of liquid filled transformers is the drying of the coil and core assembly prior to tanking. The coil and core is heated in an oven to 100 C.

During the drying, the insulating materials give up moisture and therefore shrink in dimensions. While the core and coil are still hot, all coil clamping screws are tightened with torque wrenches. All other bolts and nuts are also tightened and the transformer is then lowered into the tank. The connections between coil and core and tank are then made. The braces to the tank are secured and the tank is filled with liquid while the transformer is still warm. The cover is welded in place and the transformer is ready for tests.

TANK

The transformer tank is fabricated of heavy, hot-rolled, steel plates. A minimum number of plates are used to reduce the number of welded seams.

The tank base is fabricated of formed steel to receive and transmit the core and coil weight to the mounting pad or foundation and provides for skidding or rolling in any direction. Facilities for jacking are at the corners of the base.

Formed structural members are welded to the side walls so that the complete tank will be sufficiently reinforced to withstand a test of 10 lbs. pressure or 10 lbs. vacuum. This will prevent tank distortion during operation or pressure testing. The top of the tank is further strengthened by a flange which is used as a welding ring for securing the tank cover. An asbestos-type gasket is provided between the reinforced cover and the top flange and is compressed during the welding operation to prevent weld spatter from entering the tank. Lifting hooks are provided at the corners of the tank to permit the finished transformer, complete with liquid, to be handled by a crane.

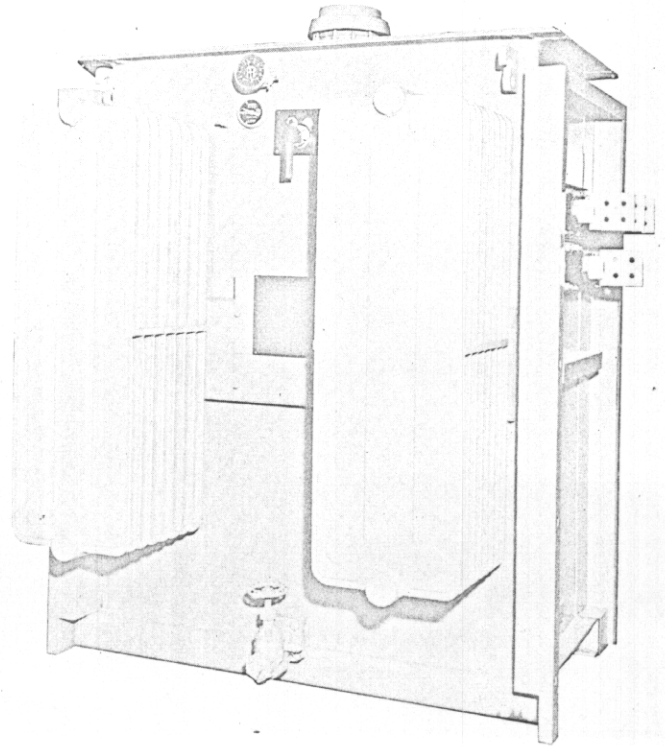

Adequate radiation surface is provided by new plate type radiators to assure that the temperature rise of the cooling liquid will not exceed the specified limit when the transformer is continuously operated at rated full load. The combination of the plate principle and special design features assures maximum cooling surface in compact form.

The entire tank is steel-grit blasted before painting to remove mill scale and rust. Each tank is painted with a rust inhibitor prime coat and two finish coats in accordance with ASA standards. The tank base is thoroughly undercoated with a rubber-base coating.

DRY-TYPE TRANSFORMERS

INSULATING MATERIAL

All insulating materials used have been thoroughly tested and proven with respect to their electrical and mechanical characteristics and are stable at operating temperatures and compatible with the cooling medium. In dry-type 150 C transformers, the wire is film insulated. Spacers and packout are silicon glass except with disk coil construction where key spacers are ceramic. Layer insulation is glass and mica cloth. These insulation materials will withstand the high operating temperature permitted in this type of transformer.

IMPREGNATION OF COILS

All coils are first dried in spring-loaded compression fixtures in temperature controlled ovens to relieve stresses and assure proper dimensions. They are next impregnated with silicon varnish under vacuum. The vacuum helps avoid tiny air pockets where corona might start, or where moisture and dirt might penetrate the coils and coil insulation. It gives the highest dielectric strength possible. Finally they are returned to the ovens to give the varnish a thorough curing.

SEALED-DRY TYPE

BUS ASSEMBLY

A superstructure, mounted on the transformer upper core clamp, contains all of the secondary and primary bus and associated insulators and connections to the high and low voltage coil leads. Both high and low voltage bus ends are brazed to the transformer bushings.

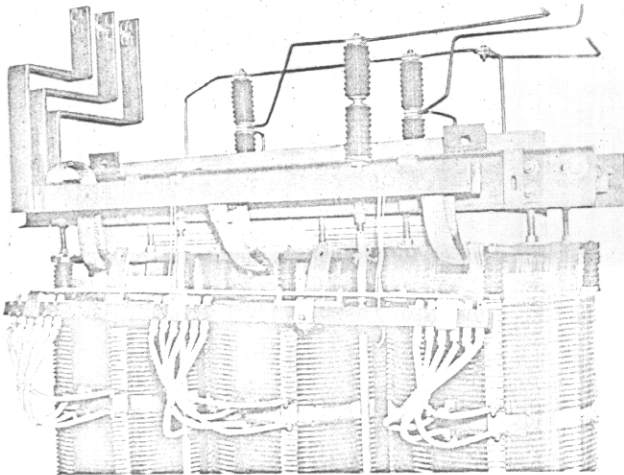

TAP CHANGER

The tap changer is the in-line type similar in construction to that used on liquid-immersed transformers. It is operated thru an externally-operated tap-changer cover.

NEW FLUOROCARBON GAS

The new fluorocarbon gas has a dielectric strength of approximately 2.8, compared with air as a base of 1.0. This higher dielectric strength results in higher basic impulse levels than nitrogen-filled or ventilated-dry type units.

As a heat-transfer medium, the higher molecular weight and lower viscosity of fluorocarbon make it more efficient than nitrogen. This results in faster heat transfer from the transformer core and coils to the tank walls and permits a lighter, more compact design.

TANK

The tank on the sealed-dry transformer is similar in construction to the liquid-immersed type. It, however, is designed to withstand 15 lbs. pressure or vacuum. Other features include: protected instrumentation, external stiffeners and hermetically-sealed glass bushings, which are jig welded to a non-magnetic bushing panel to prevent distortion during assembly.

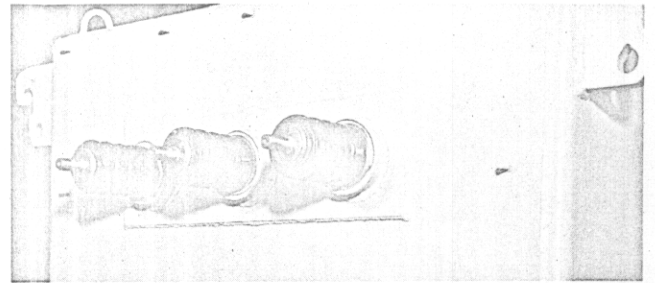

VENTILATED-DRY TYPE

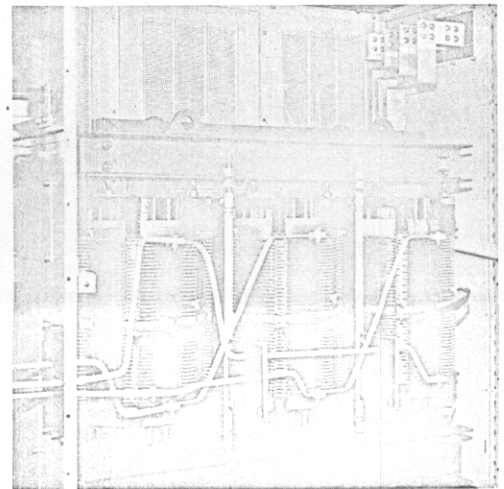

BUS ASSEMBLY

The low voltage bus is mounted to the upper core clamp of the transformer. The primary connections from the high voltage compartment are made directly to the coil ends. Tap connections are changed manually.

I-T-E INTRODUCES COST-SAVING LOGICAL-SEQUENCE

ASSEMBLY FOR VENTILATED-DRY TYPE TRANSFORMER ENCLOSURES

Saves installation time, money and floor space. Instead of shipping the enclosure already assembled around the transformer, I-T-E ships it ready to assemble.

You unpack the components in a logical sequence for easy assembly. That way you don't have to do the double work of taking the enclosure apart, making

the connections in tight quarters, then assembling it again. Installation is faster, easier, more economical—and you have a far better assurance of good results. Rigging is simplified and the transformer can more easily be moved under pipes, through doors, onto elevators and into position. Just follow these simple steps.

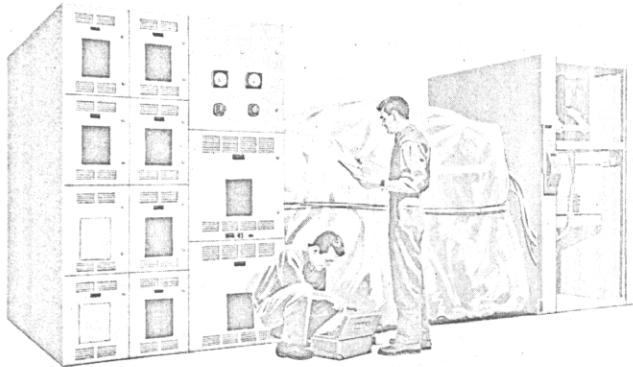

1. First step — position all components. Transformer is delivered wrapped in plastic to protect it from dirt.

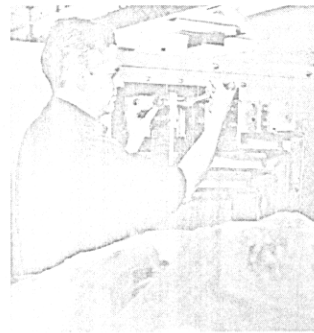

2. Make low voltage connections.

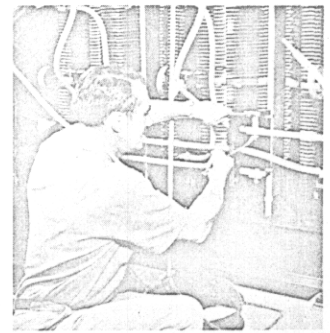

3. Make high voltage connections.



4. Connect low voltage ground.

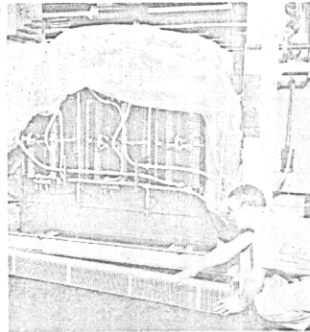

5. Assemble floor angle with screen attached.



6. Assemble corner panels.

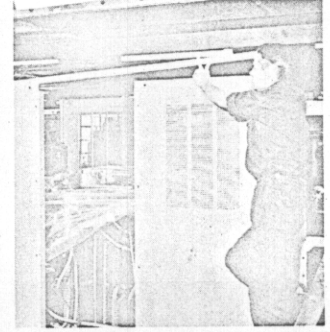

7. Assemble top cross angles.



8. Assemble temperature panel (if furnished).



9. Assemble top shelves.

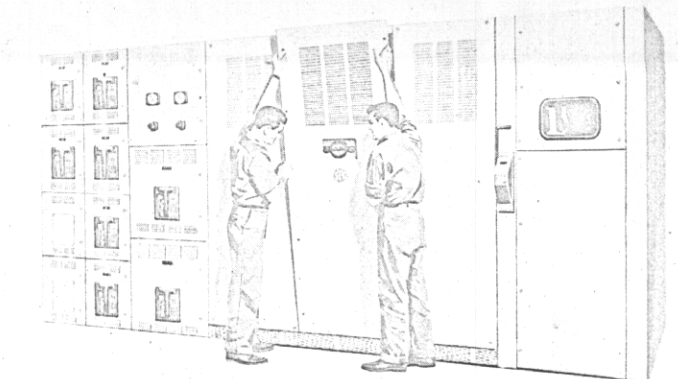

10. Assemble center panels. Jobs done.

FEATURING TIME-TESTED, COMPACT, METAL-ENCLOSED DRAWOUT SWITCHGEAR WITH MANUAL AND ELECTRICAL STORED-ENERGY K-LINE® CIRCUIT BREAKERS

TABLE 3. INTERRUPTING CAPACITY SYMMETRICAL AMPERES

Breaker Type	600 Volts	480 Volts	240 Volts
K-225	14,000	22,000	25,000
K-600	22,000	30,000	42,000
K-1600	42,000	50,000	65,000
K-3000	65,000	65,000	85,000
K-4000	85,000	85,000	130,000



OUTGOING SECTION

14

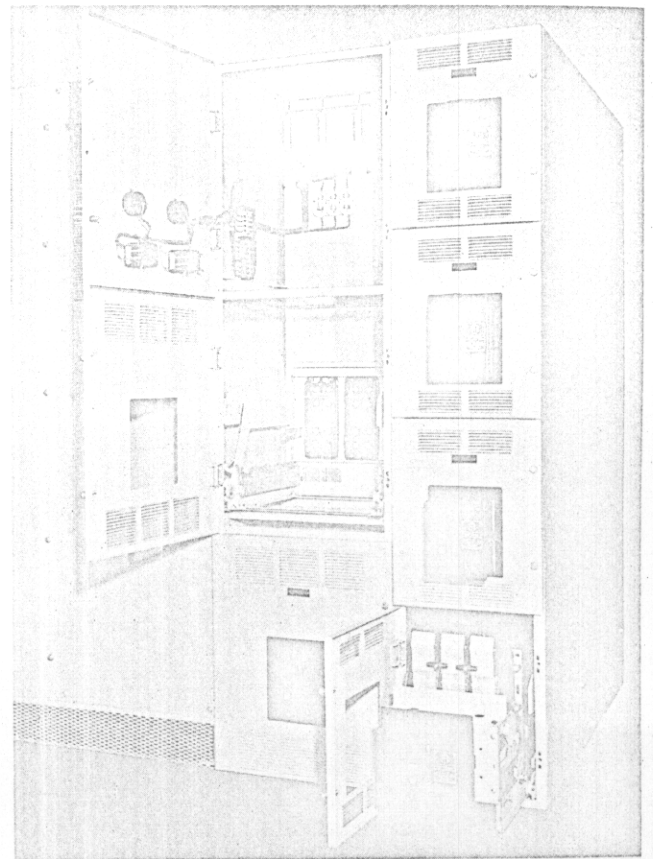

I-T-E low-voltage power switchgear is the most compact available. Circuit breakers rated up to 600 amperes can be mounted four high. In addition, the I-T-E design offers a significant reduction in weight through the use of recently developed materials with high strength-to-weight ratios. Notice also that the semi-flush circuit breaker handles do not project into the aisle. Hence, there is less risk of accidental breakage or false tripping.

Complete isolation of front compartments. Versatility of compartment sizes and hardware allow auxiliary devices or multiple breaker ratings according to your exact requirements.

The switchboards are assemblies of individual frames. Each frame is welded in a fixture. Manufacturing duplicates assure complete interchangeability in the field. Each frame is a strong, sturdy unit built to protect as well as support switching equipment. Frames are erected and securely bolted to each other. This type of construction permits versatility in selecting unit sizes for shipment.

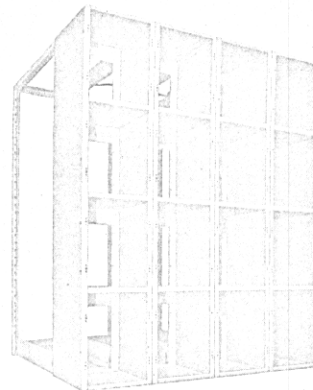

Louvered grills are scientifically designed to allow full air circulation. Hinged doors are flanged for greater rigidity. Door hinges are completely concealed by being mounted inside the enclosure and are easily adjusted for perfect door alignment. Panel screws fit easily into floating nut blocks for quick easy alignment. A coin will fit easily into the slotted head of the screw for easy tightening without use of tools.

Control-separable contacts are tiered, upper and lower, so you can mount twice as many within the narrower dimensions—as many as 32 in each compartment. This means more auxiliary circuits for your use. Standardized wiring of specific breaker devices to particular terminals makes maintenance far easier. Notice also that the control contacts are located at the bottom where they are safe and accessible.

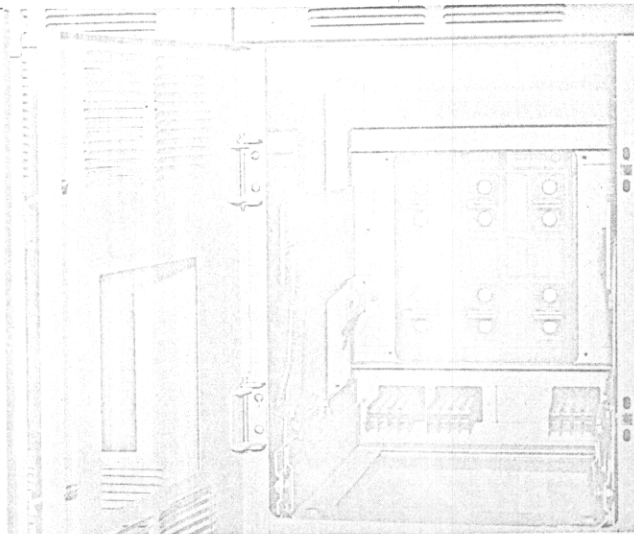

Any compartment may be converted to a circuit-breaker compartment by the installation of a cradle. A cradle comprises power and control-separable contacts and all other drawout mechanisms in a complete jig welded rigid assembly. No dependence upon switchboard frame for any critical alignment.

Versatility assured. With any one of the five K-Line breaker sizes, the cradle can easily be inserted into the K-3000 or K-4000 compartment. Any one of three sizes can be inserted into the K-1600 compartment and two sizes into the K-600 compartment.

Interchangeability assured. The cradle is secured only by bottom bolts, not side or top. Any slight misalignment of switchboard frame which may result from extreme transportation or installation abuse will not affect the alignment of the breaker.

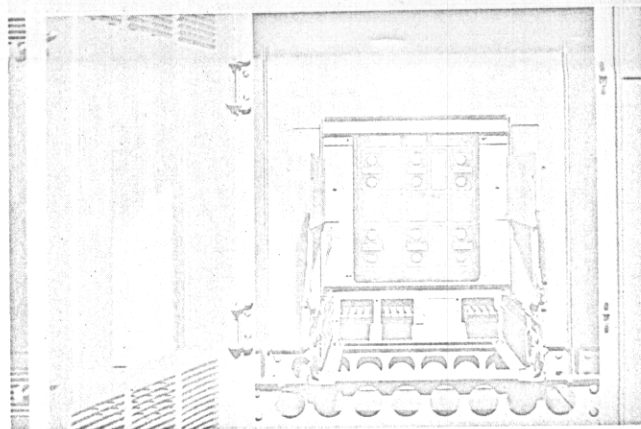
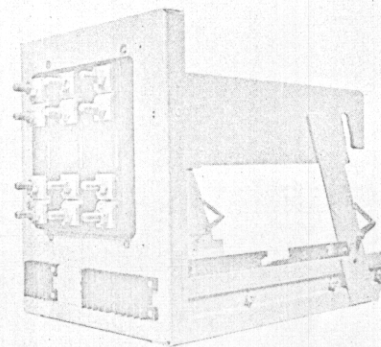

SAFE, EFFICIENT, CLOSED-DOOR DRAW-OUT

The circuit-breaker compartment door need never be opened while moving the K-Line circuit breaker from completely disconnected through test or into completely connected positions. Unique construction reduces the switchgear to three basic components; breaker, enclosure and removable cradle on which the breaker rolls for drawout. The mechanism permits racking the breaker into connected, test and disconnected positions without ever opening the compartment door. It facilitates testing and maintenance and promotes safety. A lift shutter is provided on the breaker escutcheon which permits insertion of a racking crank to move the breaker. It is completely interlocked, i.e., the shutter cannot be lifted while the circuit breaker is closed and the circuit breaker cannot be closed while the shutter is lifted. When open, the breaker can be padlocked in connected, test or disconnected positions. When pad-

locked, the breaker cannot be closed or moved to any other position.

The extendable escutcheon mounted on the circuit breaker slides through an opening into the compartment door while the spring-loaded cover plate surrounding the escutcheon is held in place by the door. Visual indication denotes all three breaker positions. Compartment doors may be opened, if desired, when the breaker is in any position. To remove the breaker from its compartment, it must be racked to the fully-disconnected position, the door opened and the breaker pulled manually to the fully-withdrawn position while it is supported by extending sliding rails. At this point the breaker may be lifted directly from the rails by means of an overhead lifting device or transfer truck or combination lifting device and transfer truck.

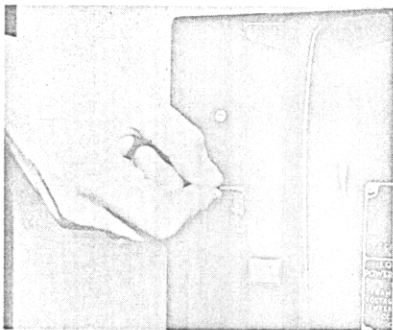

SHUTTER must be raised to insert breaker racking crank. Can not be raised when breaker contacts are closed.



INSERT CRANK to move breaker between positions. Crank cannot be inserted without raising shutter.

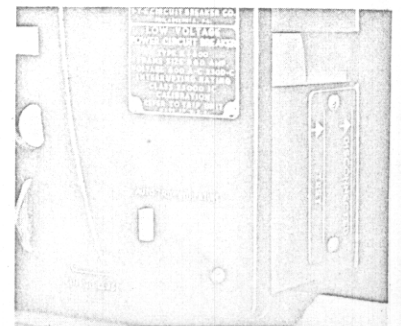

READ BREAKER POSITION from target on side of escutcheon. When breaker is in disconnected, test or connected positions, shutter will close. Breaker contacts cannot be closed until shutter is closed.

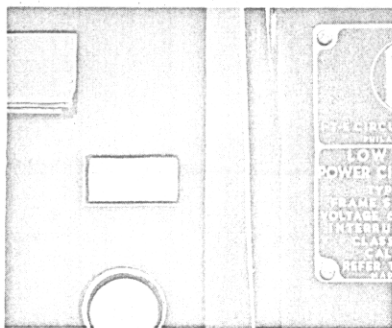

OPEN-CLOSED INDICATOR visually shows position of breaker contacts directly on front of escutcheon.

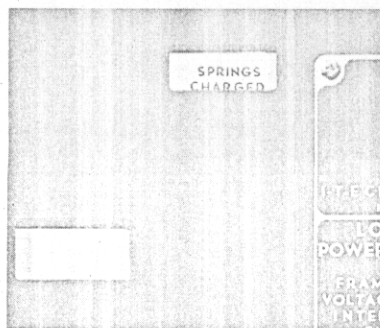

SPRING CHARGED INDICATOR visually shows condition of stored-energy springs on electrically-operated breakers and all 3000 and 4000 amp breakers.

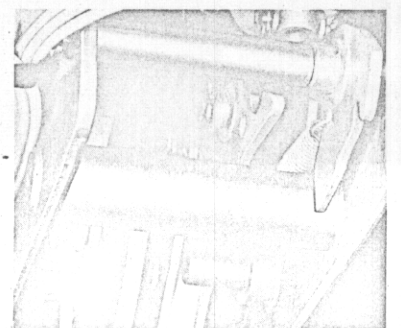

SPRING DISCHARGE DEVICE automatically discharges stored-energy springs as the breaker exits or enters the compartment. Standard on 3000 and 4000-amp breakers, optional on other electrically-operated breakers.

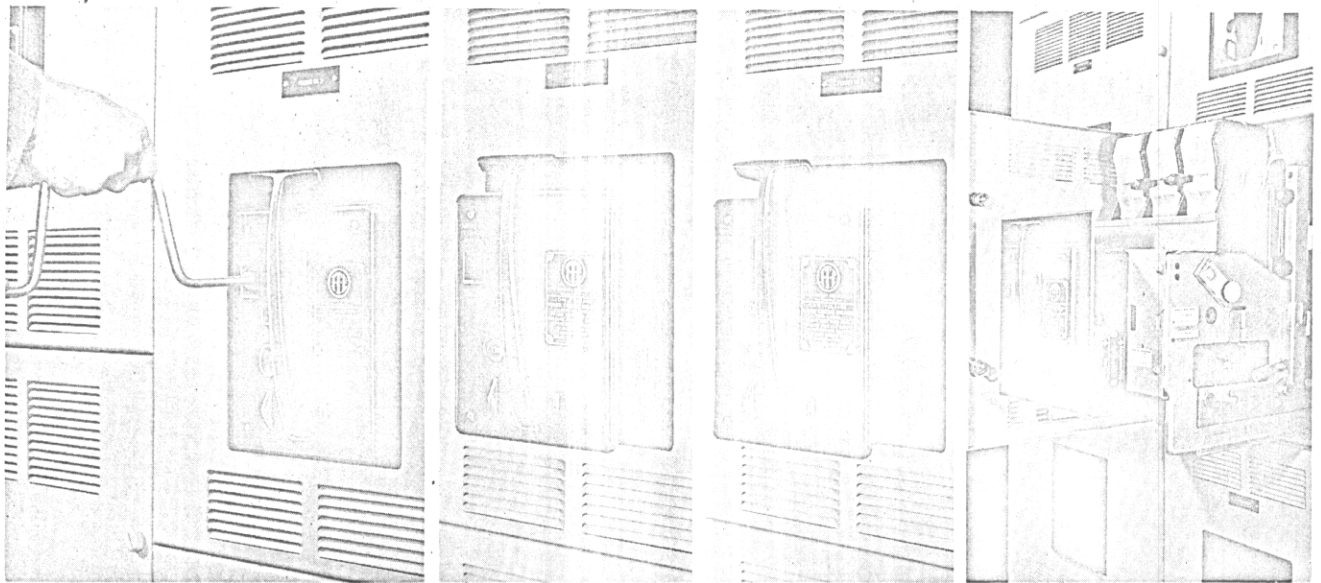

CONNECTED TEST DISCONNECTED FULLY WITHDRAWN

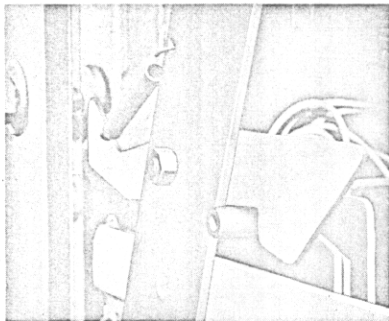

RAIL LATCH prevents breaker from rolling off track when breaker is fully withdrawn. Latch must be released to lift breaker from rails.

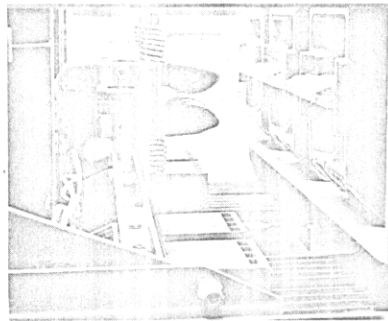

PRIMARY, SECONDARY AND GROUND CONTACTS on the circuit breaker mate sequentially in a straight-line motion with counterparts within the switchboard insuring proper operation at each position.

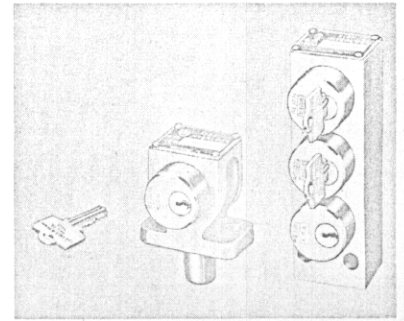

KIRK® KEY INTERLOCKS offer an unlimited number of interlocking arrangements between all components of the switchgear. Particularly adaptable to sequential operations or prevention of unauthorized operation.

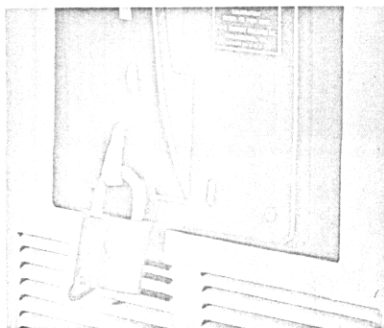

PADLOCKS — Breaker, when open, can be padlocked (with up to three locks) in all three positions. When padlocked, breaker cannot be closed or moved to any other position.

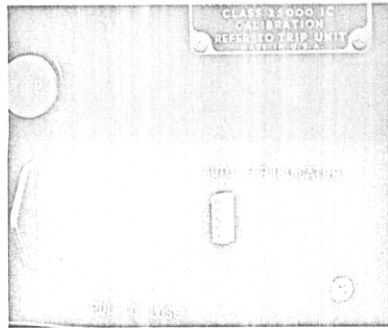

AUTOMATIC TRIP INDICATOR gives visual indication when the breaker has tripped from a fault or overcurrent.

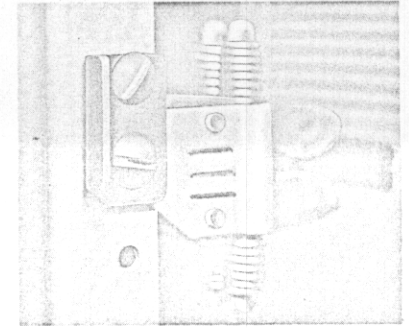

INTERFERENCE KEY on the breaker mates with slot on cradle allowing only the proper rating breaker to be inserted into the compartment. It is virtually impossible to insert a lower rating into any compartment.

MANUAL STORED ENERGY GIVES QUICK-MAKE QUICK-BREAK OPERATION



18

LESS UPKEEP, LONGER CONTACT LIFE

Manually-charged stored-energy breakers offer many advantages to its users. Of primary importance is the added safety for operating personnel. This quick-make mechanism also provides longer contact and breaker life and increases the scope of application for manual breakers. K-Line breakers cannot be teased into the closed position. A pair of powerful springs actually close the contacts. The operator simply supplies energy to the device by pulling the semi-flush closing handle downward to approximately 100°. The initial 90° fully charges the closing springs and the remaining motion releases the spring energy to drive the contacts into the closed position by a smooth cam action. The fully charged springs develop sufficient energy to close and latch the breaker safely under any conditions within the breaker rating. A flush-mounted manual trip button is located on the easily-accessible breaker escutcheon. It is also equipped with a hand-reset automatic trip indicator which provides for visual indication of automatic trip operation.

SIMPLIFIED SKETCHES SHOWING HOW MECHANISM OPERATES:

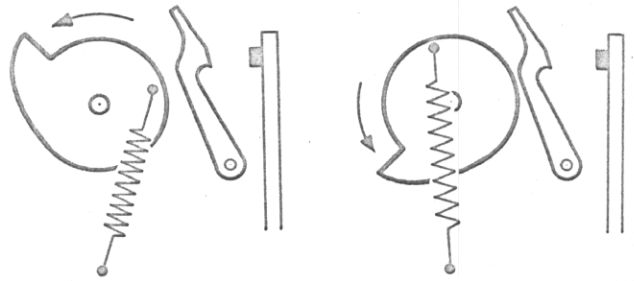

1. Energy is being stored in heavy springs.

2. At crossover point, springs will release energy.

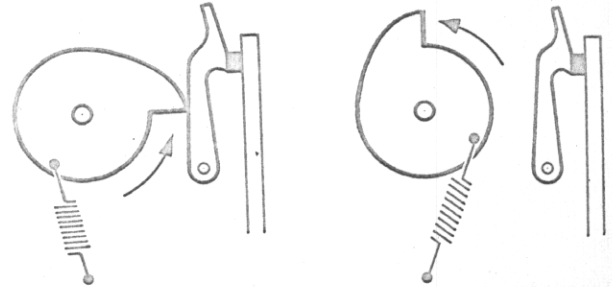

3. Cam closes contacts.

4. Contacts are closed.

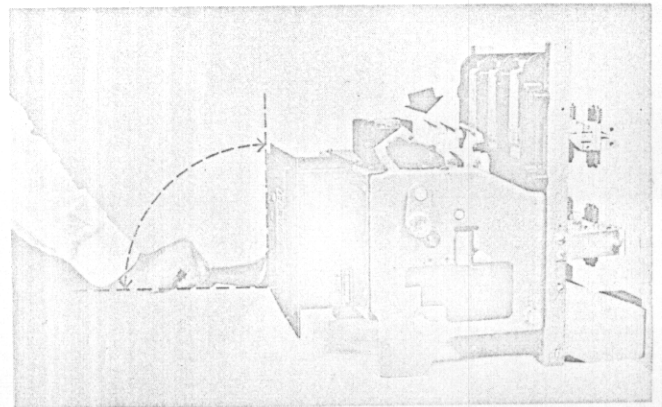

SPRINGS CHARGING

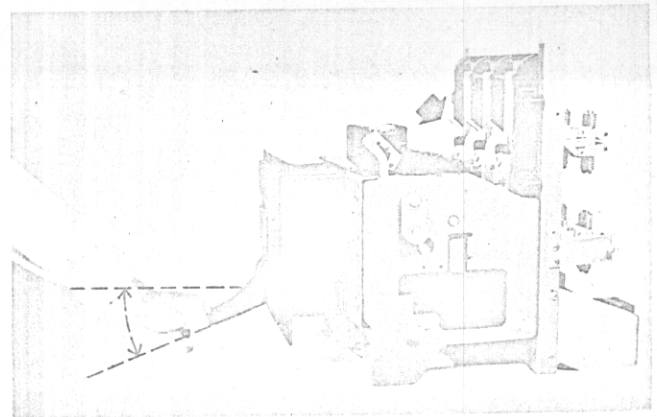

ENERGY RELEASED

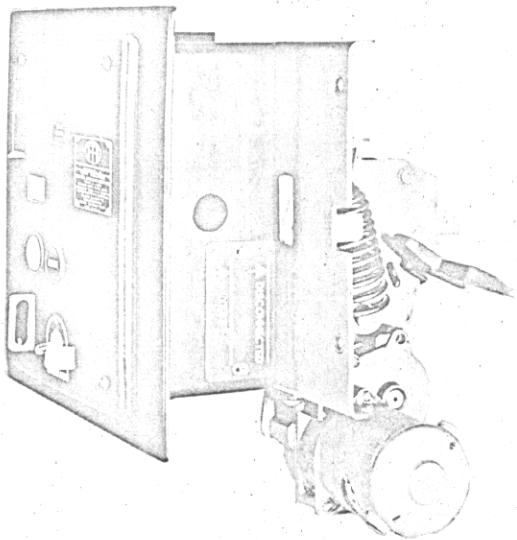

ELECTRICAL OPERATION

All K-Line circuit breakers are also available with motor-charged stored-energy closing mechanisms to be used when remote control or local electrical control is required. The normal control power required by this mechanism is only a fraction of the requirements of a powerful solenoid closing mechanism.

Fractional-horsepower motor with enclosed speed-reduction gears provides the closing energy. The high-torque, high-speed output easily charges the powerful closing springs. The springs are retained in a fully-charged condition until the energy is required for closing. Upon tripping, the springs are again recharged automatically by the mechanism. An emergency charging handle is provided for manual charging if control power is lost. Manual breakers may easily be converted to electrical operation in the field.

EXPANDED-CALIBRATION OVERCURRENT TRIP DEVICE

The K-Line overcurrent trip device offers maximum load flexibility and service continuity. Each overcurrent trip device has a much greater range of continuous current capacity compared with conventional units. When the power load grows, you simply increase the current rating of the circuit breaker by changing the setting of the trip unit. In these few minutes, you are spared the costs of new trip devices, installation and service down time.

I-T-E trip units are available in any combination of three elements, long and short time delay and instantaneous tripping. The general-purpose device provides the standard combination of long time delay and instantaneous trip while the selective-trip device provides long time delay and short time delay trip characteristics. Each unit is individually calibrated at the factory directly in amperes. Setting is simple and you have assurances of complete accuracy.



EASY TO ADJUST

Trip devices are clearly visible and within easy reach from the front. Even on electrically operated circuit breakers, they are readily accessible to the operator for quick, easy adjustment.

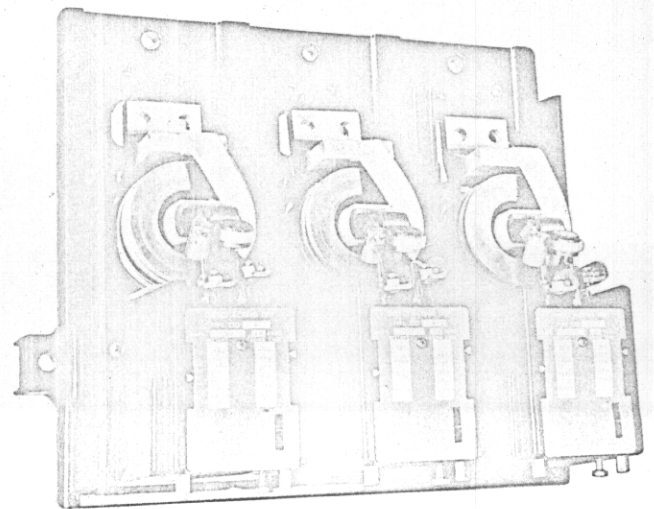

EASY TO SERVICE

The overcurrent trip device assembly is mounted on a one-piece impact-resistant molding on smaller sizes and, on larger sizes, they consist of three individual units. If repair or replacement is required, the assembly is easily removed from the back of the breaker. Associated devices need not be disturbed.

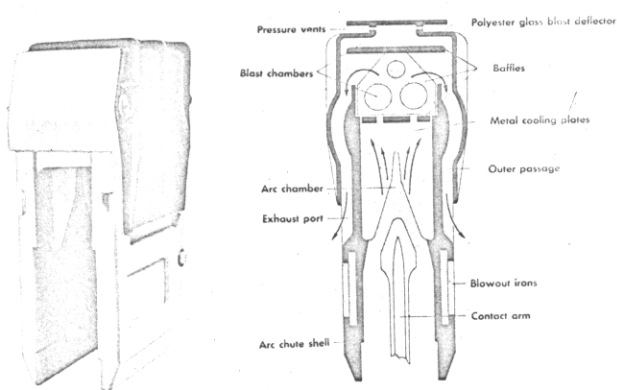

FAST-ACTING ARC QUENCHER

K-line arc quenchers employ a unique design which provides improved arcing extinction in a minimum amount of space. A unique system of baffles and deflectors confine the interruption to the arc quencher and control the discharge of gaseous arc products after they have cooled and deionized. Resulting interruption is very fast and efficient. Since no external display is seen at even the highest short circuits, the breaker requires very little overhead clearance. The arc quenchers are easily removed from the front of the breaker for contact inspection without removing the breaker from the cubicle.

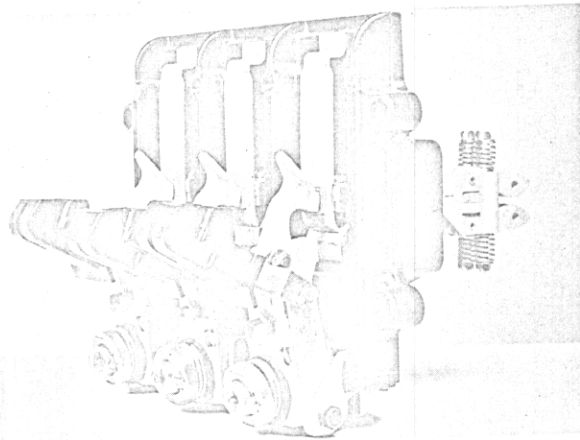

EASILY-MAINTAINED CONTACT STRUCTURE

The breaker contact structure on the smaller model is mounted on a one-piece impact-resistant molding which serves as an insulated barrier between the current carrying parts and the grounded frame. Forged contact carrying arms are 30% stronger than conventional ones. Contacts are made of high-temperature alloys which combine high conductivity with improved durability and arc-resistant properties. A unique pressure-hinged arrangement has eliminated the need for flexible conductors. On larger units, three single moldings are employed.

K-DON® CURRENT-LIMITING CIRCUIT BREAKER

200,000 AMPERES INTERRUPTING CAPACITY WITH COMPLETE RANGE OF OPERATION OF K-LINE LOW-VOLTAGE CIRCUIT BREAKERS

TABLE 4

CIRCUIT BREAKER TYPE	FRAME SIZE AMPERES	MAXIMUM CONTINUOUS CURRENT AMPERES	MAXIMUM INTERRUPTING RATING SYM. AMPERES
K-DON-600	600	600	200,000
K-DON-1600	1600	1600	200,000

The K-Don circuit breaker is a compact-versatile protective device which incorporates all of the features of the K-Line circuit breaker and the current-limiting characteristics of the Amp-trap®. It is essentially a K-Line circuit breaker with such proven features as expanded-range overcurrent trip, manual or electrical stored-energy closing, undervoltage trip, shunt trip, auxiliary switches, etc. Physically connected in series to the line side at the rear are standard Amp-trap current limiting fuses.

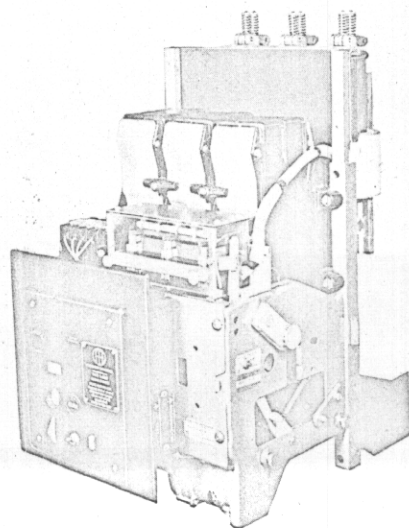

The circuit breaker performs its normal functions of time delay and instantaneous tripping throughout its entire range of interrupting capacity. At any selected point either below or at the interrupting rating of the circuit breaker the fuse takes over giving protection up to 200,000 amperes. The fuse never blows below the pre-selected area thus saving nuisance replacements. This system affords vast flexibility in applying pinpointed protection to any type of electrical apparatus.

For complete information on K-Don equipment see Bulletin No. 4300-1A

BUS & CABLE COMPARTMENTS

Single-main horizontal bus and vertical risers are located as close to front of switchboard as possible, providing large area for auxiliary equipment and cable makeup. Vertical mounting of bus provides maximum ventilation. The top sheet of each frame is removable to facilitate installation of overhead conduit and cable. Small wiring when required is contained neatly and safely in wiring troughs. Inserts between compartments prevent abrasion of wires. Wide-opening hinged rear door permits easy access to cable and bus compartments. No bolts to remove or heavy steel panels to lift.

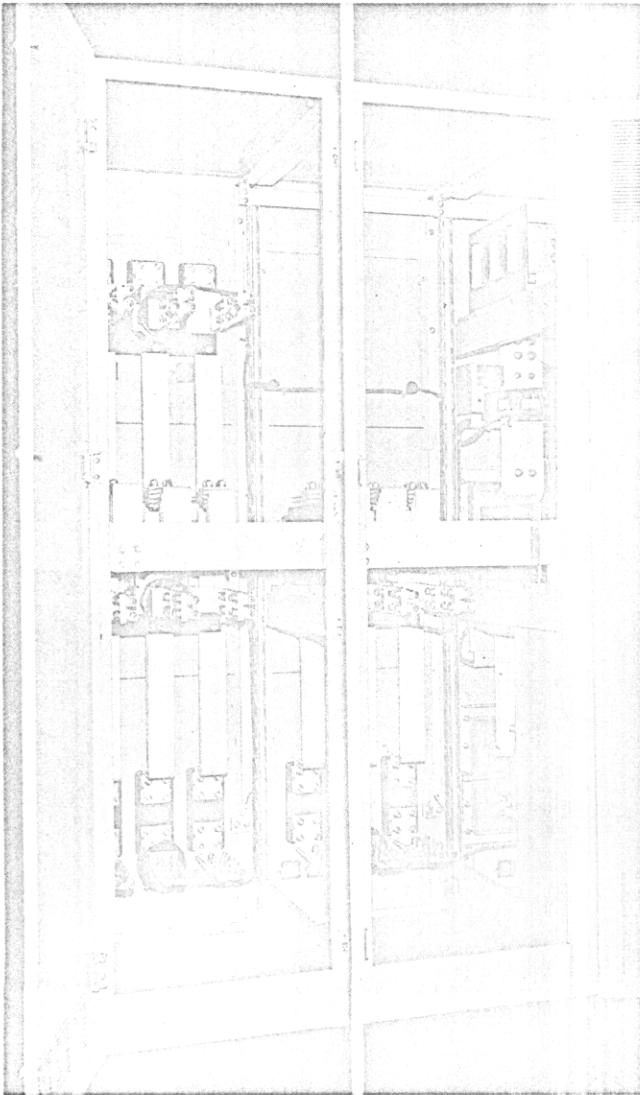

Aluminum bus is silver-plated over its entire area and is braced against movement in any direction under all possible short-circuit conditions. Bus taps extending between vertical risers are insulated with polyester glass. All joints are bolted. Pre-slotted mounting members permit flexibility to add mounting supports when required in the field for incoming cables, etc.

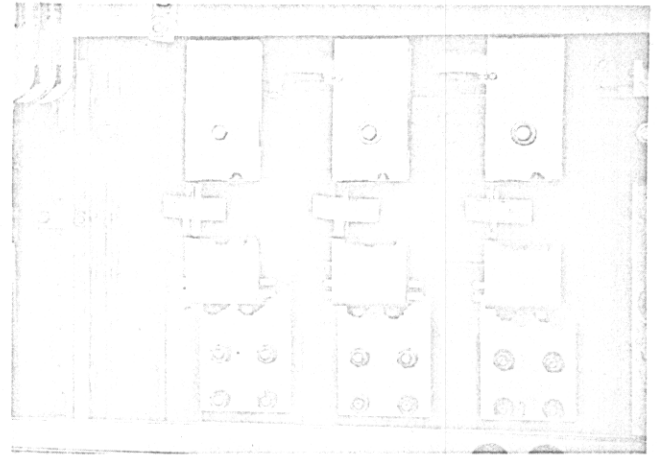

I-T-E bushing current transformers utilizing high-permeability, low-loss cores and toroidal windings are employed in this switchgear. They are small in size and high in accuracy. They are slipped over the bus and are rigidly mounted and braced to withstand maximum short circuit forces.

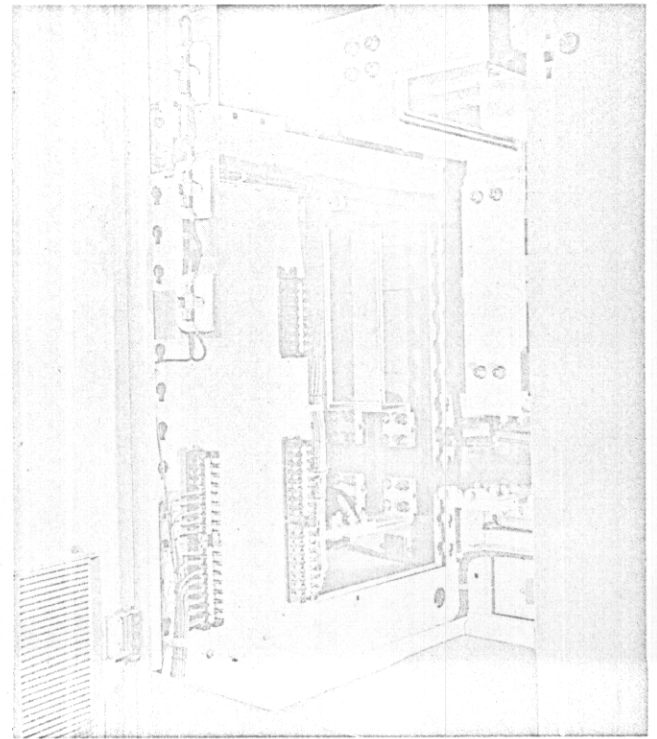

Terminal blocks for secondary and control wiring are located uniformly in each frame. These terminations are kept at a safe distance from the main buses and are readily accessible from the back of the switchboard. Vertical stacking of terminal blocks simplifies customer's connections. Fuses are mounted on a separate accessible panel.

LIFTING DEVICE

For ease of handling K-line circuit breakers, a traveling lifting device can be provided. This device is supported from the front section of the assembly and will not affect any incoming power or control cables at the rear bus section. The hoist can be moved the full length of the switchboard and with the aid of a lifting yoke, the breaker can be lifted from the floor or from the completely withdrawn breaker cradle. Lifting power is provided through a removable hand crank, worm-driven mechanism and sturdy flexible cable. Although the driving mechanism is designed for easy hand operation, the weight of the breaker will not allow the load to move even when the crank is unattended or removed.

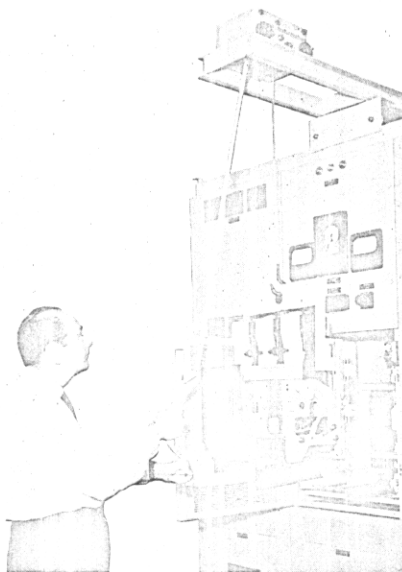

ACCESSORIES

Each factory-assembled switchboard is shipped with circuit breaker racking crank and lifting yoke as standard accessories. A maintenance handle is included on electrically-operated breakers only.

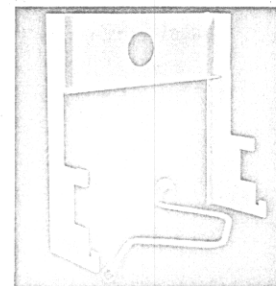

WEATHERPROOF WALK-IN CONSTRUCTION

Weatherproof walk-in construction provides allweather protection when the switchboard must be located out of doors. The same arrangement principles are used in weatherproof as in standard indoor construction, including the all-positions-with-door-closed feature. In addition, this construction provides approximately three feet of aisle space on the breaker side to protect equipment and personnel from inclement weather. Also provided are large areas at the top and bottom of each frame for cable entry. Large working area is provided in the rear compartment for pulling and connecting cables.

The standard arrangements provided:

1. Manually-operated lifting device.
2. Filtered louvers and screened vents, front and rear.
3. Strip heaters to prevent condensation.
4. Convenience outlets and interior lighting.
5. Weatherproof gasketing throughout.

A control-power transformer may be mounted in an auxiliary compartment, if required, to furnish power to outlets and strip heaters.

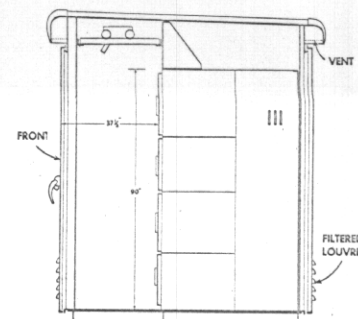
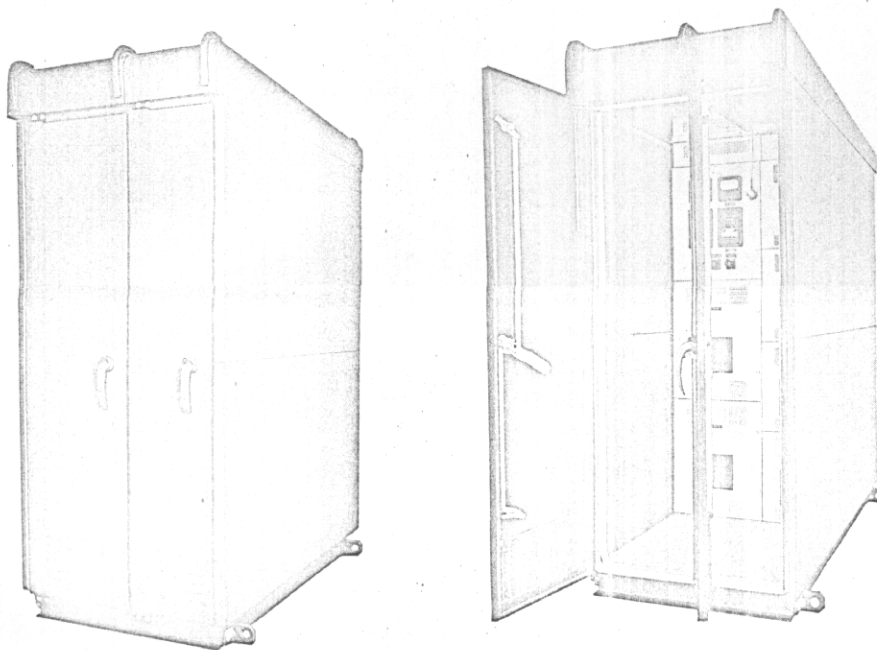

OTHER PRIMARY DEVICES

AIR TERMINAL CHAMBER INDOOR - OUTDOOR

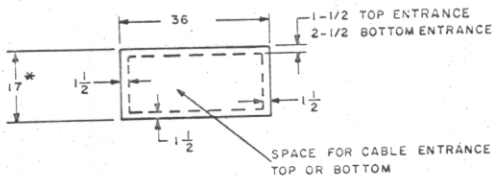
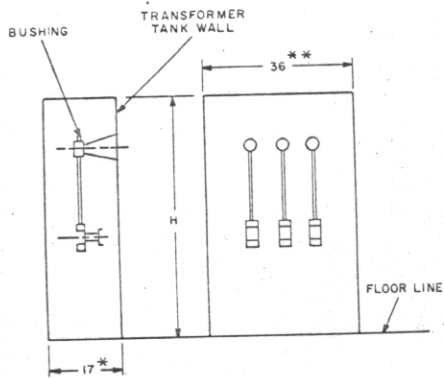

24

* ADD 10" WHEN 15KV POTHEADS ARE USED WITH 500KVA AND 750KVA LIQUID OR SEALED-DRY TRANSFORMERS
ADD 1" ON ALL VENTILATED-DRY TRANSFORMERS.

** WHEN USED WITH VENTILATED-DRY TRANSFORMER - MATCH TRANSFORMER DEPTH

TABLE 5
FULL-HEIGHT AIR TERMINAL CHAMBERS

TRANSFORMER DIMENSION	LIQUID		SEALED DRY		VENTILATED DRY	
	KVA	KV	BOTTOM ENTR.	TOP ENTR.	BOTTOM ENTR.	TOP ENTR.
500	5	60	70	80	90	90
	15	80	80	100	100	
750	5	70	80	80	90	90
	15	90	80	100	100	
1000	5	70	80	80	90	90
	15	90	80	100	100	
1500	5	80	90	90	100	110
	15	100	90	110	110	

OIL CUTOUTS INDOOR - OUTDOOR

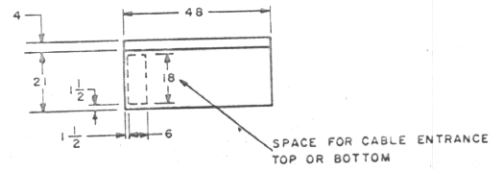
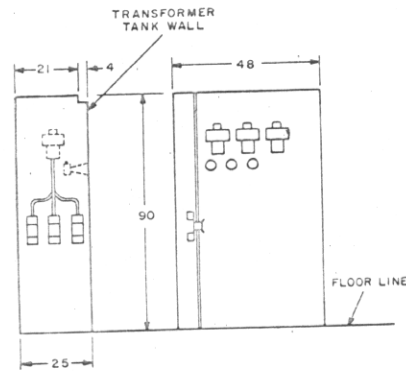

NOTES:
1. FOR OUTDOOR, ADD 2" HIGH ROOF WITH 1/2" OVERHANG
2. TOP ENTRANCE NOT AVAILABLE WITH POTHEADS

METAL-CLAD SWITCHGEAR

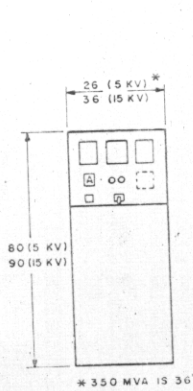

INDOOR

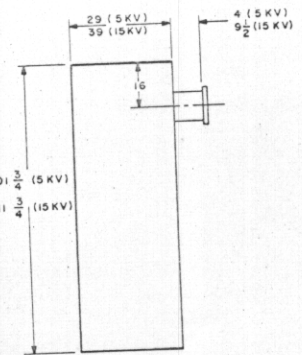
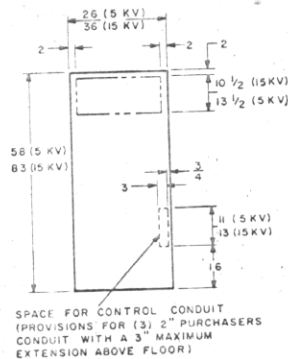

OUTDOOR

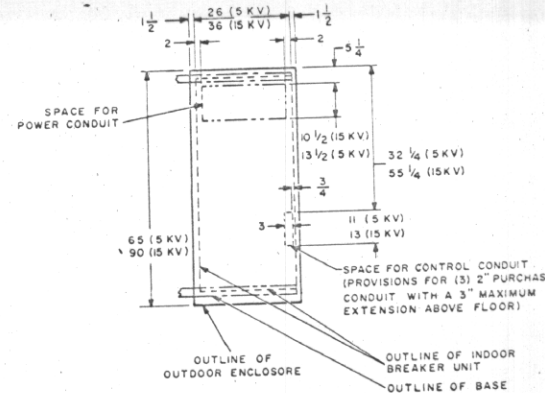

DIMENSIONS

INTERRUPTER SWITCH,

SELECTOR SWITCH — INDOOR

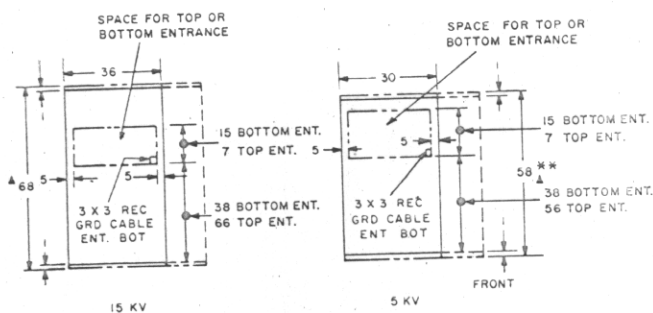
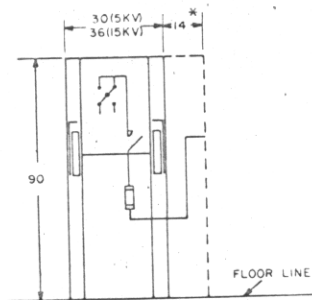

- * USE TRANSITION WITH LIQUID OR SEALED DRY TRANSFORMER ONLY
- ** WHEN USED WITH VENTILATED DRY TRANSFORMER—MATCH TRANSFORMER DEPTH
- ▲ ADD 10" FOR TOP ENTRANCE.

SELECTOR SWITCH — OUTDOOR

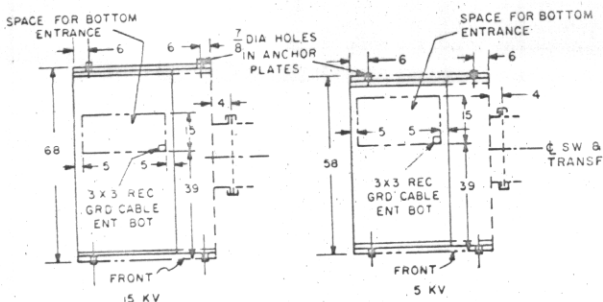
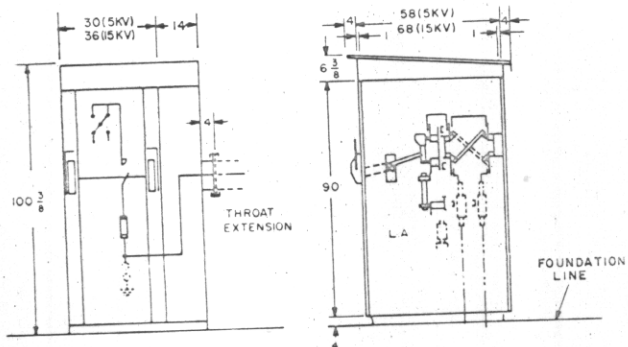

VENTILATED-DRY — INDOOR

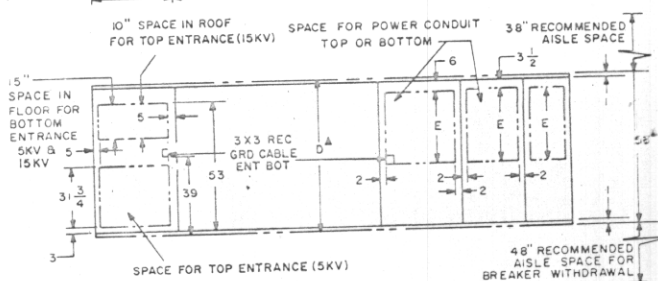
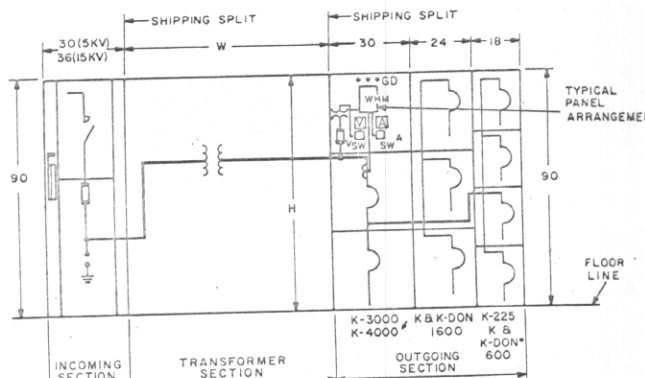

- K-DON MOUNTED 3-HIGH ONLY
- ▲ INCOMING SWITCH AND OUTGOING SWITCHGEAR MUST MATCH TRANSFORMER DEPTH, EXCEPT WHEN 2-3/C POTHEADS ARE USED FOR TOP ENTRANCE ON 15 KV SWITCH—ADD 10"
- ▲ K-4000, 2-45" HIGH COMPARTMENTS, 1 BREAKER IN BOTTOM COMPARTMENT.

LIQUID (OIL & ASKAREL) & SEALED-DRY — OUTDOOR

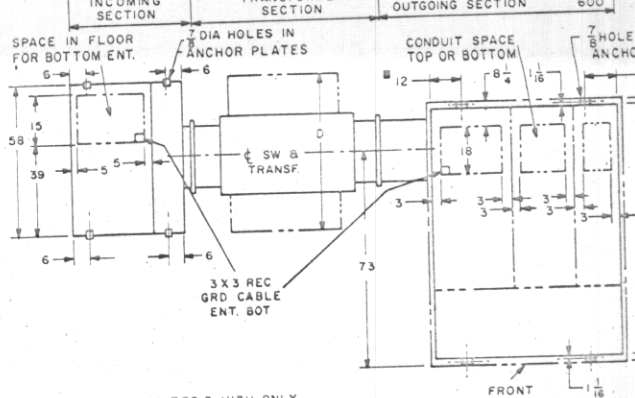
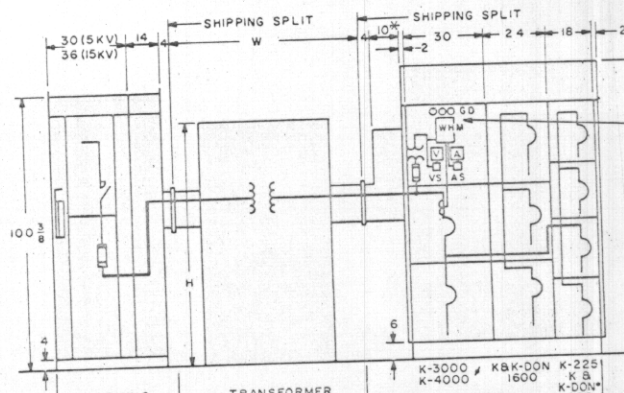

- K-DON MOUNTED 3-HIGH ONLY
- * ELIMINATE 10" L EXTENSION FOR 1500 AND 2000 KVA TRANSFORMER, EXCEPT WHEN MAIN BREAKER IS K-3000 WITH CT'S ON LINE SIDE, OR WHEN K-DON BREAKER IS 88" IF K-600 OR K-1600 ARE MANUALLY OPER. AND HAVE NO AUX. DEVICES, THAT WIRING TO TERMINAL BLOCKS. CABLE ENTRANCE SPACE REDUCES TO 12"—108" MAIN BREAKER IS K-4000.
- 6" WHEN SINGLE UNIT ONLY, 72" MAX BETWEEN ANCHOR BOLTS.
- ▲ K-4000, 2-45" HIGH COMPARTMENTS, 1 BREAKER IN BOTTOM COMPARTMENT.

TRANSFORMER AND SECONDARY SWITCHGEAR

TABLE 6
VENTILATED-DRY

KVA	INCOMING SECTION	DIMENSIONS		
		WT	H	D
500	5 KV	36	72	
	15 KV			
750 and 1000	5 and 15 KV	78	90	58
1500 and 2000	5 and 15 KV	90	96	68

† A 14" transition compartment on the outgoing side must be added when no space above breaker is available for bus transition.

TABLE 7
LIQUID (ASKAREL) & SEALED-DRY

KVA	INCOMING RATING	DIMENSIONS					
		LIQUID			SEALED-DRY		
		W*	H	D	W*	H	D
225		30 ^{1/2}	72 ^{1/2}	60 ^{1/2}			
300		51	70	41 ^{3/8}			
500	5 KV	52	71 ^{1/2}	46 ^{5/8}	72	80 ^{1/4}	48
	15 KV				76		54
750	5 KV	60 ^{1/2}	79 ^{1/8}	60 ^{1/2}	74	80 ^{1/4}	50
	15 KV				78		54
1000	5 KV	61 ^{1/2}	83 ^{1/8}	61 ^{1/2}	78	80 ^{1/4}	52
	15 KV				82		56
1500	5 KV	65 ^{1/2}	91 ^{1/8}	62	86	90 ^{1/4}	54
	15 KV				88		58
2000	5 KV	68 ^{3/8}	97 ^{1/8}	70 ^{1/2}	88	90 ^{1/4}	56
	15 KV				92		60
2500		72 ^{3/8}	102 ^{1/8}	75 ^{1/2}			

* Subtract 4" for collar on HV side when used with full ht. at terminal chamber, cutouts, or liquid filled switches.

LIQUID (ASKAREL) & SEALED-DRY — INDOOR

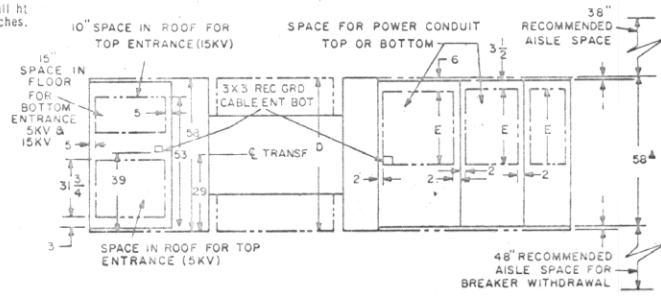
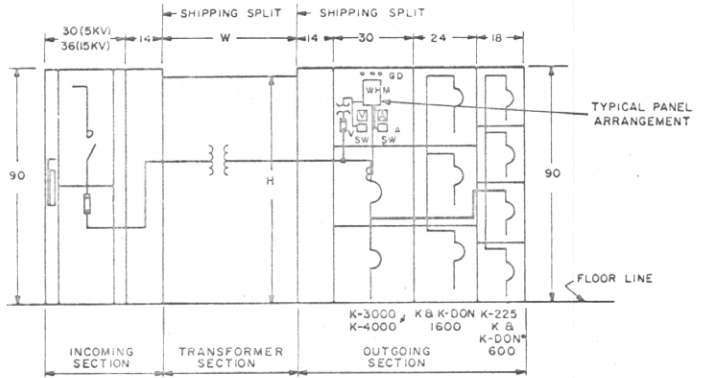

- K-DON MOUNTED 3-HIGH ONLY
- ▲ DEPTH MUST BE 68" WITH K-4000, 4W OR K-3000 AND K-4000 WITH 5 OR 6000 AMP COPPER.
- † K-4000, 2-45" HIGH COMPARTMENTS, 1 BREAKER IN BOTTOM COMPARTMENT.

TABLE 8
LOW-VOLTAGE SWITCHGEAR

Depth	Top Ent.	Bottom Ent.
	E	E
58	28 ^{1/2}	23 ^{1/2}
68	39	37

SWITCHBOARD TIE BUS DUCT INDOOR — OUTDOOR

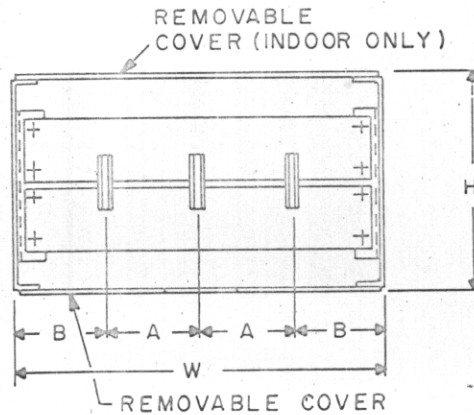

- NOTES:
INDOOR BUS DUCT IS VENTILATED ON BOTH SIDES AND BOTTOM.
OUTDOOR BUS DUCT IS UNVENTILATED, CONDUCTOR SIZE IS INCREASED.

TABLE 10
BUS DUCT — 600 VOLTS

CAP. IN AMPS 50 C RISE 60 CYCLE	SIZE			
	A	B	W	H
600 - 800	5	6	22	12
1000 - 1200	5	6	22	16
1600 - 2000	5	6	22	16
2500	5	6	22	16
3000	5	6	22	16
4000	9	8	34	16

TABLE 9A
OIL AND ASKAREL

KVA	DIMENSIONS			
	W †	H OIL	H ASKAREL	D
225	42 ^{1/2}	69	72 ^{1/2}	60 ^{1/2}
300	63	66 ^{1/2}	70	41 ^{3/8}
500	64	68	71 ^{1/2}	46 ^{5/8}
750	78 ^{1/2}	74 ^{7/8}	79 ^{1/8}	60 ^{1/2}
1000	79 ^{1/2}	78 ^{1/8}	83 ^{1/8}	61 ^{1/2}
1500	83 ^{1/2}	86 ^{7/8}	91 ^{1/8}	62
2000	86 ^{5/8}	92 ^{7/8}	97 ^{1/8}	70 ^{1/2}
2500	90 ^{5/8}	97 ^{7/8}	102 ^{1/8}	75 ^{1/2}

† When using full ht. air terminal chamber, cutouts or liquid filled switches, subtract 10" for 225 thru 500 kva and 16" for 750 thru 2500 kva.

TABLE 9B
SEALED-DRY

KVA	INCOMING RATING	W †	H	D
500	5KV	94	80 ^{1/4}	48
	15KV	103		54
750	5KV	95	80 ^{1/4}	50
	15KV	105		54
1000	5KV	100	80 ^{1/4}	52
	15KV	109		56
1500	5KV	108	90 ^{1/4}	54
	15KV	115		58
2000	5KV	110	90 ^{1/4}	56
	15KV	119		60

† When using full ht. air terminal chamber, cutouts or liquid filled switches, subtract 15" for 5 kv and 20" for 15 kv.

WEIGHTS LBS.

**TABLE 11A — INCOMING HIGH-VOLTAGE SECTION
PRIMARY DEVICES**

PRIMARY ENTRANCE HPL-C SW. FRAME INCL. 600A SW.	DEPTH						3 FUSES	1-3/C OR 3-1/C POT- HEAD	3 L. A.
	INDOOR		OUTDOOR INCL. TRANSIT						
	58"	68"	58"	68"	58"	68"			
5KV Unfused	900	1000	1350				150	35	
15KV Unfused	1200	1300	1800	1950			200	50	
5KV Unfused with Sel. SW.	1100	1200	1550				150	35	
15KV Unfused with Sel. SW.		1600		2250			200	50	
FULL HEIGHT AIR TERMINAL CHAMBER	HEIGHTS							100	
	KV	60	70	80	90	100	110		
	5	240	260	290	320	340			
	15	260	280	310	340	330	360		
Oil Fused Cutouts	800								

**TABLE 11B
METAL-CLAD SWITCHGEAR**

Type of Breaker	Continuous Current Amperes	Breaker	(Does Not Include Breaker)	
			Indoor 58"	Outdoor 65"
5HK75	1200	575	1325	1690
5HK250	1200	575	1325	1690
5HK250	2000	625	1458	1823
Add Per Switchboard for End Panels				545
5HK350	1200	775	1400	1790
5HK350	3000	1550	—	—
Add Per Switchboard for End Panels				590
			83"	90"
7.5HK500	1200	1200	2170	2675
7.5HK500	2000	1250	2411	2916
15HK500	1200	1200	2170	2675
15HK500	2000	1250	2411	2916
Add Per Switchboard for End Panels				775
			91"	98"
15HK750	1200A	1450	2260	2778
15HK750	2000A	1500	2501	3019
Add Per Switchboard for End Panels				835

5HK—Potential transformer drawout unit with 3 PT's—216 lbs.
 15HK—Potential transformer drawout unit with 3 PT's—315 lbs.
 5 & 15KV—Stationary mounted control power transformers to 15 KVA—305 lbs.
 5HK—Drawout fuse unit—160 lbs.
 15HK—Drawout fuse unit—295 lbs.

TABLE 12 — TRANSFORMER SECTION

TRANSFORMER TYPE	KV	TRANSFORMER KVA								14" TRANSITION	
		225	300	500	750	1000	1500	2000	2500	58"	66"
VENTILATED-DRY	5	1970	2320	3220	5275	6575	8915	10815	12915	400	450
	15			4975	5675	6975	9315	11315	13415		
LIQUID ASKAREL	5 or	4675	5150	6175	9250	10600	13650	16400	19750	400	450
	15	3750	4150	5050	7600	8800	11350	13750	16550		
LIQUID OIL	5			5900	6700	8100	10800	12900		400	450
	15			6400	7200	8700	11300	15500			

**TABLE 13A — OUTGOING LOW-VOLTAGE SECTION
SWITCHGEAR**

TYPE	FRAME WIDTH	DEPTH						
		INDOOR		OUTDOOR				
		58"	68"	98"	108"			
BREAKER UNITS INCL. BUS DOES NOT INCLUDE BREAKER	K-225	18	750	850	1300	1420		
			K-600	900	1000	1450	1570	
	K-1600	24	1000	1200	1650	1880		
			K-3000	30	1550	1750	2300	2535
					K-4000	1600	1800	2350
END PANELS				1000 PER SWBD	1125 PER SWBD			
TRAVELING LIFTING DEVICE				100 PER SWBD				

TABLE 13B — CIRCUIT BREAKERS

TYPE	Man. Oper.	Elec. Oper.
K-225	103	133
K-600	112	142
K-1600	185	215
K-3000	650	680
K-4000	700	730
K-DON-600	158	188
K-DON-1600	296	326

SELECTION AND APPLICATION

Incoming Line Section

TABLE 14, AIR INTERRUPTER SWITCHES (FUSED OR UNFUSED)

VOLTAGE RATING				CURRENT RATING				INTERRUPTING LIFE ON CLOSE-OPEN DUTY CYCLE NUMBER OF INTERRUPTIONS					FAULT CLOSING WITH SPRING OPERATOR	
Nom. KV	Max. Design KV	Withstand 60 Cycle KV	Impulse KV	Contin. Current A	At KV	10 Cycle Momentary Rms Asym. KA	4 Sec. Short-Time Rms Sym. KA	KV	Power Factor	200A	400A	600A	UNFUSED Rms Asym. KA	FUSED
4.8	5.5	19	60	600	5.5	61	38	5.5		1000	1000	300	40	Fuse Interrupting Rating
				1200										
7.2/13.8	14.5	36	95	600	15			15	0.8	800	400	300		
				1200										

TABLE 15A, POWER FUSE SELECTION I-T-E TYPE CL CURRENT-LIMITING (50/60 CYCLES) NON-DISCONNECT TYPE

SYSTEM KV L-L	INTERRUPTING RATING		FUSE KV
	MVA SYM	KA ASYM	
2.4	150	57.6	2.4 & 4.8
4.16	216	48.0	2.4 & 4.8
4.16	216	48.0	4.8
4.8	250	48.0	2.4 & 4.8
4.8	250	48.0	4.8
6.9	335	44.8	7.2

SYSTEM KV L-L	INTERRUPTING RATING		FUSE KV
	MVA SYM	KA ASYM	
7.2	350	44.8	7.2
11.5	499	40.0	13.8
12.0	520	40.0	13.8
12.47	540	40.0	13.8
13.2	573	40.0	13.8
13.8	600	40.0	13.8

TABLE 15B

SYSTEM KV L-L	2.4				4.16				4.8				6.9 — 7.2				11.5 — 12.47				13.2 — 13.8			
	TRANSF. KVA	I F.L.	MIN FU	133% FU	MAX FU	I F.L.	MIN FU	133% FU	MAX FU	I F.L.	MIN FU	133% FU	MAX FU	I F.L.	MIN FU	133% FU	MAX FU	I F.L.	MIN FU	133% FU	MAX FU	I F.L.	MIN FU	133% FU
112.5	27.1	40E	40E	65E	15.6	25E	25E	40E	13.6	20E	20E	30E	9.41	15E	15E	25E	5.65	10E	10E	15E	4.93	10E	10E	15E
225	54.1	80E	80E	125E	31.2	40E	50E	65E	27.1	40E	40E	65E	18.3	30E	30E	40E	11.3	20E	20E	30E	9.85	20E	20E	25E
300	72.2	100E	100E	150E	41.6	50E	65E	100E	36.1	50E	50E	80E	25.2	40E	40E	50E	15.1	25E	25E	30E	13.1	20E	20E	30E
500	120	125E	200E	250E	69.4	80E	100E	150E	60	80E	80E	125E	41.8	50E	65E	65E	25.1	40E	40E	50E	21.9	30E	30E	50E
750	180	200E	250E	300E	104	125E	150E	200E	90	100E	125E	150E	62.8	—	—	—	37.7	50E	50E	80E	32.8	40E	50E	65E
1000	241	300E	—	300E	139	150E	200E	270A	120	125E	200E	200E	83.8	—	—	—	50.2	65E 50E	80E 65E	100E	43.7	50E	65E	80E
1500	361	—	—	—	208	270A	300E	300E	180	200E	270A	300E	126	—	—	—	75.3	80E	100E	125E	65.6	80E	100E	125E
2000	482	—	—	—	278	300E	—	362A	241	250E	362A	300E	167	—	—	—	100	125A 100E	156A	170A	87.5	100E	125E	170A
2500	602	—	—	—	348	—	—	—	300	362A	—	362A	210	—	—	—	126	125E	170A	170A	109	125E	156A	170A

E—NEMA standard fuse 30 C rise above 40 C average ambient

A—50 C rise above 40 C average ambient

Minimum fuse sizes shown will carry transformer full load continuously and will pass inrush.

Maximum fuse sizes shown will protect transformer from secondary bolted faults.

TABLE 16A. METAL-CLAD SWITCHGEAR

CIRCUIT BREAKER TYPE	5HK-75	5HK-250	5HK-350	7.5HK-500	15HK-500	15HK-750	15HK-1000
Current Ratings (Continuous)	1200A	1200 & 2000A	1200, 2000 & 3000A	1200 & 2000A	1200 & 2000A	1200, 2000 & 2500A	1200 & 3000A
Rated MVA.(Sym)	75	250	350	500	500	750	1000
Current, Momentary	20000A	60000A	80000A	70000A	40000A†	60000A‡	80000A
Current, 4 Sec.	12500A	37500A	50000A	44000A	25000A	37500A	50000A
Voltage, Rated KV	4.16	4.16	4.16	7.2	13.8	13.8	13.8
Voltage, Max. Design KV	4.76	4.76	4.76	8.25	15.0	15.0	15.0
Voltage, Min. at Rated MVA	3.5	3.85	4.0	6.6	11.5	11.5	11.5
I.C. at Rated KV	10500A	35000A	48600A	40000A	22000A	33000A	43500A
I.C. at Max. KV	9100A	30200A	42400A	35000A	19000A	29000A	38500A
I.C. at Min. KV	12500A	37500A	50000A	44000A	25000A	37500A	50000A

† 60,000 Amp Momentary Available
 ‡ 80,000 Amp Momentary Available

TABLE 16B

CIRCUIT BREAKER TYPE	5HK	7.5 & 15 HK
60 Cycle Withstand	19 KV	36 KV
B.I.L.	60 KV	95 KV
Interrupting Time (0-100% IC)	5 cycles	5 cycles
Average Closing Time	6.5 cycles	10 cycles
Average Tripping Time	1.8 cycles	1.8 cycles
Spring Charging Time—Max	2 seconds	2 seconds

TABLE 16C

CONTROL POWER REQUIREMENTS						
Control Voltage	Closing Coil		Tripping Coil		Charging Motor	
	Voltage Range Volts	Current Amps	Voltage Range Volts	Current Amps	Voltage Range Volts	Avg Current Amps
48 V. D-C	35-50	10.7	28-60	10.7	—	—
125 V. D-C	90-130	6.7	70-140	6.7	90-130	7.0
250 V. D-C	180-260	2.2	140-280	2.2	180-260	3.5
115 V. A-C	95-125	4.5	95-125	4.5	95-125	11
230 V. A-C	190-250	2.3	190-250	2.3	190-250	5.5

Transformer Section

TABLE 17. STANDARD TRANSFORMER RATINGS

TYPE	KVA 3 Phase Self Cooled	KVA 3 Phase Forced Air Cooled	Primary Voltage Delta	SECONDARY VOLTAGE		Standard Impedence	NEMA Sound Level db	
				208Y/120 240 delta	480Y/227 480 delta		Self Cooled	Fans Run- ing
				Liquid- Immersed Oil Askarel 65 C Rise	112½ 150 225 300 500 750 1000 1500 2000 2500		— — — — 862 1150 1725 2300 2875	2400 4160 4800 6900 7200 12000 13200 13800
Vent-Dry 150 C Rise	112½ 150 225 300	— — — —	2400 4160 4800	X X X X	X X X X	3.0 3.5 4.5 5.0	50 50 55 55	— — — —
Sealed-Dry	300 500 750 1000 1500 2000 2500	— 1000 1333 2000 2666 3333	2400 4160 4800 6900 7200 12000 13200 13800	X X X X X X X	X X X X X X X	5.0 5.0 5.75 5.75 5.75 5.75 5.75	57 59 63 63 64 65 66	— — — — — — —

TABLE 18. DIELECTRIC TESTS:

Trans- former Type	Voltage Class (KV)	Applied Test 60 Cycles All KVA Ratings	Basic Impulse Levels (1.5 x 40 Full Wave)		Induced Test 7200 Cycles All KVA Ratings
			500 KVA and below	501 KVA and above	
Liquid- Immersed	1.2	10 kv	30 kv	45 kv	Twice normal voltage
	2.5	15 kv	45 kv	60 kv	
	5.0	19 kv	60 kv	75 kv	
	8.66	26 kv	75 kv	95 kv	
	15.0	34 kv	95 kv	110 kv	
ALL KVA RATINGS					
Venti- lated- Dry	1.2	4 kv	10 kv	20 kv	Twice normal voltage
	2.5	10 kv	20 kv	25 kv	
	5.0	12 kv	25 kv	65 kv	
	8.66	19 kv	65 kv	65 kv	
	15.0	31 kv	65 kv	65 kv	
Sealed- Dry	1.2	10 kv	30 kv	45 kv	Twice normal voltage
	2.5	15 kv	45 kv	60 kv	
	5.0	19 kv	60 kv	75 kv	
	8.66	26 kv	75 kv	95 kv	
	15.0	34 kv	95 kv	95 kv	

TABLE 19. STANDARD TAPS on I-T-E unit substation transformers are as follows:

NORMAL VOLTAGE	TAPS			
2400	2520	2460	2340	2280
4160	4360	4260	4055	3950
4800	5040	4920	4680	4560
6900	7245	7070	6730	6555
7200	7560	7380	7020	6840
12000	12600	12300	11700	11400
13200	13860	13530	12870	12540
13800	14400	14100	13500	13200

Outgoing Section

TABLE 20 RATINGS—LOW-VOLTAGE POWER CIRCUIT BREAKERS

A-C VOLTS	FRAME SIZE AMPERES	ASYMMETRICAL INTERRUPTING RATING WITH		SYMMETRICAL INTERRUPTING RATING WITH		ASYM-METRICAL 30 CYCLE SHORT TIME RATING AMPERES	SYM-METRICAL 30 CYCLE SHORT TIME RATING AMPERES	ASYM-METRICAL FAULT CURRENT LIMIT 2-STEP CASCADE AMPERES	SYM-METRICAL FAULT CURRENT LIMIT 2-STEP CASCADE AMPERES	DIRECT-ACTING TRIP DEVICES					TYPE OF OPERATION (MANUAL OR ELECTRICAL)
		INSTAN-TANEOUS TRIP AMPERES	DELAYED TRIP AMPERES	INSTAN-TANEOUS TRIP AMPERES	DELAYED TRIP AMPERES					MINIMUM PICKUP SETTING WITH					
										MAXI-MUM COIL RATING AMPERES	DELAYED TRIP				
											INSTAN-TANEOUS TRIP AMPERES	MINI-MUM BAND AMPERES	INTER BAND AMPERES	MAXI-MUM BAND AMPERES	
208 and 240	225	30,000	15,000	25,000	14,000	15,000	14,000	60,000	50,000	225	20	72	72	130	M or E
	600	50,000	25,000	42,000	22,000	25,000	22,000	100,000	85,000	600	130	130	130	200	M or E
	1,600	75,000	50,000	65,000	42,000	50,000	42,000	120,000	100,000	1,600	400	240	240	400	M or E
	3,000	100,000	75,000	85,000	65,000	75,000	65,000	150,000	130,000	3,000	1,600	1,600	1,600	1,600	M or E
4,000	150,000	100,000	130,000	85,000	100,000	85,000	150,000	130,000	4,000	3,200	3,200	3,200	3,200	M or E	
4 8 0	225	25,000	15,000	22,000	14,000	15,000	14,000	50,000	42,000	225	12	72	72	130	M or E
	600	35,000	25,000	30,000	22,000	25,000	22,000	70,000	60,000	600	70	130	130	200	M or E
	1,600	60,000	50,000	50,000	42,000	50,000	42,000	100,000	85,000	1,600	250	240	240	400	M or E
	3,000	75,000	75,000	65,000	65,000	75,000	65,000	100,000	85,000	3,000	1,600	1,600	1,600	1,600	M or E
4,000	100,000	100,000	85,000	85,000	100,000	85,000	100,000	85,000	4,000	3,200	3,200	3,200	3,200	M or E	
6 0 0	225	15,000	15,000	14,000	14,000	15,000	14,000	30,000	25,000	225	12	72	72	130	M or E
	600	25,000	25,000	22,000	22,000	25,000	22,000	50,000	42,000	600	20	130	130	200	M or E
	1,600	50,000	50,000	42,000	42,000	50,000	42,000	100,000	85,000	1,600	130	240	240	400	M or E
	3,000	75,000	75,000	65,000	65,000	75,000	65,000	100,000	85,000	3,000	1,600	1,600	1,600	1,600	M or E
4,000	100,000	100,000	85,000	85,000	100,000	85,000	100,000	85,000	4,000	3,200	3,200	3,200	3,200	M or E	

Series Coil Ratings: 20, 40, 70, 125, 225, 400, 600, 800, 1600, 3000, 4000. For 5000 or 6000 ampere breakers refer to Home Office.

Recommended maximum continuous current rating of largest feeder breaker in per cent of transformer (self-cooled) rated current, when primary power fuses are included is 40% for current limiting type and 50% for non-current limiting type.

SELECTION OF LOW-VOLTAGE POWER CIRCUIT BREAKERS IN LOW-VOLTAGE DRAWING SWITCHGEAR

Selection of Breaker Tripping Characteristics

The degree of service continuity available from a low voltage distribution system depends on the degree of coordination between circuit-breaker tripping characteristics.

Three methods of tripping coordination are in general use, each representing a different degree of service continuity and of initial cost.

These methods, or systems, combine breaker ratings and tripping characteristics as follows:

Fully-Rated System

A fully-rated system is one in which both the main and the feeder breakers have adequate interrupting capacity for the fault current available at the point of application.

All breakers are equipped with long time delay and instantaneous overcurrent trips. Ordinarily only the breaker nearest the fault will open. The main breaker will trip, however, when the fault current exceeds its instantaneous trip setting, and service continuity may be lost.

Cascade System

A cascade system is one in which only the main breaker has adequate interrupting capacity. Feeder breakers with inadequate interrupting capacity may be used provided the main breaker trips instantaneously to protect them when the fault current reaches a dangerous level.

All breakers are equipped with long time delay and instantaneous trips. The main (back-up) breaker is

set to trip instantaneously when the fault current through the feeder (backed-up) breaker exceeds 80% of the feeder breaker interrupting capacity.

The cascade system offers a minimum initial cost when maximum continuity of service is not required.

Selective System

A selective system is one in which both the main and feeder breakers have adequate interrupting capacity for the fault current available at the point of application.

The main breaker is equipped with long time delay and short time delay trips. The feeder breakers are equipped with long time delay and instantaneous trips unless they are required to be selective with other protective devices nearer the load. In this case, the feeders are equipped with long time delay and short time delay trips.

In a selective system, only the breaker nearest the fault trips. Service continuity is thus maintained through all other breakers.

The main breaker trips only on a bus fault. The selective system offers a maximum of service continuity, with a slightly higher first cost than the other systems described.

Selection of Breaker Type

These three basic factors determine the selection of a breaker after a decision has been reached on the type of system required:

System voltage and frequency

Continuous current
Available fault current

Having chosen the right table, refer to that part of it which covers the system voltage.

Use of Application Tables

Application Tables 21A, B and C provide for proper selection of the circuit-breaker type required. They should be used as follows:

- Use Table 21A for a fully-rated system
- Use Table 21B for a cascade system
- Use Table 21C for a selective system

Look for the horizontal line listing an available fault current nearest the one required at the point of application (let the nearest one be higher, rather than lower than the exact fault current needed).

Then select the circuit-breaker type listed where the Available Fault Current line crosses the vertical column headed with the wording: Continuous Current Rating.

TABLE 21-A FULLY RATED SYSTEM

System Voltage And Frequency	Available Fault Current 3 Phase Average Symmetrical RMS Amps	Continuous Current Rating																								
		15	20	30	40	50	70	90	100	125	150	175	200	225	250	300	350	400	500	600	800	1000	1200	1600	2000	2500
481-600 25-60 Cycle	14000	K-225																								
	22000	K-600																								
	42000	K-1600																								
	65000	K-3000																								
	85000	K-4000																								
241-480 50-60 Cycle	22000	K-225																								
	30000	K-600																								
	42000	K-1600																								
	50000	K-3000																								
	85000	K-4000																								
Up to 240 50-60 Cycle	22000	K-225																								
	25000	K-225																								
	30000	K-600																								
	42000	K-600																								
	50000	K-1600																								
	65000	K-1600																								
	85000	K-1600																								

Note 1. Manually-charged stored energy closed circuit breakers may be applied within their 600 v, 480 v, or 240 v interrupting rating, provided their instantaneous trips are set below their short time* ratings.

TABLE 21-B SECOND-STEP CASCADE SYSTEM

(First Step Cascade System—same as Fully Rated)

System Voltage And Frequency	Available Fault Current 3 Phase Average Symmetrical RMS Amps	Continuous Current Rating																								
		15	20	30	40	50	70	90	100	125	150	175	200	225	250	300	350	400	500	600	800	1000	1200	1600	2000	2500
481-600 25-60 Cycle	25000	K-225																								
	42000	K-600																								
	85000	K-1600																								
241-480 50-60 Cycle	42000	K-225																								
	60000	K-600																								
	85000	K-1600																								
Up to 240 50-60 Cycle	50000	K-225																								
	65000	K-600																								
	85000	K-600																								
	100000	K-1600																								

Note 2. Circuit breakers subjected to fault currents in excess of their interrupting ratings are to be electrically operated and are to be controlled from a position other than in front of the breaker to provide protection for the operator when the breaker is closing against a fault current.

TABLE 21-C SELECTIVE SYSTEM

System Voltage and Frequency	Available Fault Current 3 Phase Average Symmetrical RMS Amps	Short Time Delay Band	Continuous Current Rating																
			100	125	150	175	200	225	250	300	350	400	500	600	800	1000	1200	1600	2000
Up to 600	14000	Minimum	K-225																
		Intermediate	K-225																
		Maximum	K-225																
50-60 Cycle	22000	Minimum	K-600																
		Intermediate	K-600																
		Maximum	K-600																
	42000	Minimum	K-1600																
		Intermediate	K-1600																
		Maximum	K-1600																
	65000	Minimum	K-1600																
		Intermediate	K-1600																
		Maximum	K-1600																
	85000	Minimum	K-1600																
		Intermediate	K-1600																
		Maximum	K-1600																

Note 3. The manually-charged stored-energy closed circuit breakers with delayed trip may be applied within their short time* ratings.

*The short time rating is equal to the 600 v interrupting rating.

TABLE 22-A. K-225, K-600, AND K-1600 CIRCUIT-BREAKER CONTROL POWER REQUIREMENTS

Nominal Control Voltage	Average Closing Motor Current (amperes)	Shunt Trip Current (amperes)	CLOSING RELAY CURRENT-AMPERES		Under Voltage Trip Current (amperes)	Closing Circuit Voltage Range	Trip Circuit Voltage Range	Under Voltage Trip Range
			Anti Pump	Release				
115 v a-c	10	2.3	.15	1.5	.6	95-125	95-125	35-69
230 v a-c	5	1.15	.075	.75	.3	190-250	190-250	69-138
48 v d-c	—	3.14	.15	1.33	.47	36-52	28-60	14-29
125 v d-c	10	1.4	.06	.56	.2	90-130	70-140	38-75
250 v d-c	5	.7	.03	.28	.1	180-260	140-280	75-150

TABLE 22-B. K-3000 AND K-4000 CIRCUIT-BREAKER CONTROL POWER REQUIREMENTS

Nominal Control Voltage	Average Closing Motor Current (amperes)	Shunt Trip Current (amperes)	CLOSING RELAY CURRENT-AMPERES		Trip Current Under Voltage (amperes)	Closing Circuit Voltage Range	Trip Circuit Voltage Range	Under Voltage Trip Range
			Anti Pump	Release				
115 v a-c	11	4.5	.15	4.5	.6	95-125	95-125	35-69
230 v a-c	5.5	2.25	.075	2.25	.3	190-250	190-250	69-138
125 v d-c	7.0	2.3	.06	2.3	.2	90-130	70-140	38-74
250 v d-c	3.5	1.15	.03	1.15	.1	180-260	140-280	75-150

TABLE 23. EXPANDED RANGE DUAL MAGNETIC DIRECT ACTING OVERCURRENT TRIP DEVICES FOR K-LINE CIRCUIT BREAKERS

BREAKER TYPES	I-T-E Maximum Continuous Coil Ratings (amperes)	I-T-E Adjustable Long Time Delay Pickup Points	I-T-E Adjustable Instantaneous Pickup Points	BREAKER TYPES	I-T-E Maximum Continuous Coil Ratings (amperes)	I-T-E Adjustable Long Time Delay Pickup Points	I-T-E Adjustable Instantaneous Pickup Points
K-225	20	12 15 18 20 25	75 125 200 300	K-600 K-1600	400	250 300 350 400 500	2000 4000 6000
K-225 K-600	40	20 25 30 40 50	150 250 400 600	K-600	600	400 500 600 750	2500 4000 6000 9000
K-225 K-600	70	40 50 60 70 90	250 500 750 1100	K-1600	800	400 500 600 800 1000	2500 5000 7500 10000
K-225 K-600	125	70 90 100 125 160	450 800 1200 1900	K-1600	1600	800 1000 1200 1600 2000	5000 10000 15000 20000
K-225 K-600 K-1600	225	130 150 175 200 225 285	750 1500 2400 3400	K-3000	3000	1600 2000 2400 3000 4000 4800	10000 20000 30000 40000
K-4000	4000			K-4000	4000	3200 4000 4800 5600 6400	20000 40000 60000

32

TABLE 24. RATINGS—K-DON CIRCUIT BREAKERS

CIRCUIT BREAKER	FRAME SIZE AMPERES	VOLTAGE A-C	MAXIMUM CONTINUOUS CURRENT AMPERES	MAXIMUM INTERRUPTING RATING AMPERES	CIRCUIT BREAKER COIL RATING AMPERES	AMP-TRAP CONTINUOUS RATING AMPERES
K-Don-600 K-Don-1600	600 1600	up to 600 up to 600	600 1600	200,000 200,000	20-600 130-1600	400-2000 400-3000

TABLE 25-A. LOW VOLTAGE POWER CIRCUIT BREAKER APPLICATION

480 VOLTS

Transformer Rating 3-ph KVA and Impedance Per Cent	Maximum Short Circuit KVA Available from Primary System	Normal Load Continu- ous Current Amperes	Short-Circuit Current Total RMS Symmetrical Amperes			Minimum Frame Size Air Circuit Breaker Recommended			
			Transformer Alone	100% Motor Load	Combined	M*	C	I	S
						Main Breaker	Cascaded Feeder	Feeder with Instant. Trip	Feeder with Selective Trip
112.5 4.5% ▲	50,000	135	2,860	500	3,360	K-225	K-225	K-225	K-225
	100,000		2,920		3,420				
	150,000		2,940		3,440				
	250,000		2,980		3,480				
	500,000		3,000		3,500				
150 4.5% ▲	50,000	180	3,600	700	4,300	K-225	K-225	K-225	K-225
	100,000		3,860		4,560				
	150,000		3,910		4,610				
	250,000		3,930		4,630				
	500,000		3,970		4,670				
225 4.5% ▲	50,000	271	5,460	1100	6,560	K-600	K-225	K-225	K-225
	100,000		5,720		6,820				
	150,000		5,800		6,900				
	250,000		5,900		7,000				
	500,000		6,790		7,890				
300 5.0%	50,000	361	6,480	1400	7,880	K-600	K-225	K-225	K-225
	100,000		6,800		8,200				
	150,000		6,960		8,360				
	250,000		7,040		8,440				
	500,000		7,120		8,520				
500 5.0%	50,000	601	10,000	2400	12,400	K-1600	K-225	K-225	K-600
	100,000		10,960		13,360				
	150,000		11,280		13,680				
	250,000		11,600		14,000				
	500,000		11,840		14,240				
750 5.75%	50,000	902	12,400	3600	16,000	K-1600	K-225	K-225	K-600
	100,000		13,840		17,440				
	150,000		14,480		18,080				
	250,000		14,960		18,560				
	500,000		15,360		18,960				
1000 5.75%	50,000	1203	15,600	4800	20,400	K-1600	K-225	K-600	K-1600
	100,000		17,920		22,720				
	150,000		18,800		23,600				
	250,000		19,600		24,400				
	500,000		20,240		25,040				
1500 5.75%	50,000	1804	20,640	7200	27,840	K-3000	K-225	K-600	K-1600
	100,000		24,960		32,160			K-1600	
	150,000		26,800		34,000			K-1600	
	250,000		28,480		35,680			K-1600	
	500,000		29,840		37,040			K-1600	
2000 5.75%	50,000	2406	24,720	9600	34,320	K-3000	K-225	K-1600	K-1600
	100,000		30,560		40,160		K-600	K-1600	
	150,000		34,080		43,680		K-600	K-1600	
	250,000		36,720		46,320		K-600	K-1600	
	500,000		38,960		48,560		K-600	K-3000	
2500 5.75%	50,000	3010	27,900	12000	39,900	K-4000	K-225	K-1600	K-1600
	100,000		36,300		48,300		K-600	K-1600	
	150,000		40,400		52,400		K-600	K-3000	
	250,000		44,500		56,500		K-600	K-3000	
	500,000		48,100		62,100		K-600	K-3000	

* The transformer main secondary breakers are in most cases determined by continuous current instead of fault current. For this reason breakers in the M column are usually larger than those listed in the I column. The values listed in the M column allow a breaker continuous rating approximately 25% above the transformer self-cooled full load current. If the transformer has a fan cooled rating a main secondary breaker larger than indicated by column M may be required.

▲ Short-circuit currents are calculated with impedances shown applying to liquid immersed transformers only. Refer to Table 17 for ventilated dry type impedances.

TABLE 25-B.

Transformer Rating 3-ph KVA and Impedance Per Cent	Maximum Short Circuit KVA Available from Primary System	Normal Load Continu- ous Current Amperes	Short-Circuit Current Total RMS Symmetrical Amperes			Minimum Frame Size Air Circuit Breaker Recommended			
			Transformer Alone	100% Motor Load	Combined	M*	C	I	S
						Main Breaker	Cascaded Feeder	Feeder with Instant. Trip	Feeder with Selective Trip
112.5 4.5% ▲	50,000	271	4,800	1100	5,900	K-600	K-225	K-225	K-225
	100,000		5,840		6,940				
	150,000		5,920		7,020				
	250,000		5,960		7,060				
	500,000		6,010		7,110				
150 4.5% ▲	50,000	361	7,520	1400	8,920	K-600	K-225	K-225	K-225
	100,000		7,740		9,140				
	150,000		7,840		9,240				
	250,000		7,880		9,280				
	500,000		7,960		9,360				
225 4.5% ▲	50,000	541	11,120	2200	13,320	K-600	K-225	K-225	K-600
	100,000		11,640		13,840				
	150,000		11,840		14,040				
	250,000		12,020		14,220				
	500,000		12,160		14,360				
300 5.0%	50,000	722	12,880	2900	15,780	K-1600	K-225	K-225	K-600
	100,000		13,600		16,500				
	150,000		13,920		16,820				
	250,000		14,080		16,980				
	500,000		14,320		17,220				
500 5.0%	50,000	1203	20,080	4800	24,880	K-1600	K-225	K-600	K-1600
	100,000		21,840		26,640				
	150,000		22,560		27,360				
	250,000		23,120		27,920				
	500,000		23,600		28,400				
750 5.75%	50,000	1804	24,960	7200	32,160	K-3000	K-225	K-600	K-1600
	100,000		27,760		34,960				
	150,000		28,880		36,080				
	250,000		29,920		37,120				
	500,000		30,640		37,840				
1000 5.75%	50,000	2406	31,120	9600	40,720	K-3000	K-225	K-1600	K-3000
	100,000		35,680		45,280		K-225		
	150,000		37,520		47,120		K-225		
	250,000		39,120		48,720		K-600		
	500,000		41,360		50,960		K-600		

* The transformer main secondary breakers are in most cases determined by continuous current instead of fault current. For this reason breakers in the M column are usually larger than those listed in the I column. The values listed in the M column allow a breaker continuous rating approximately 25% above the transformer self-cooled full load current. If the transformer has a fan cooled rating a main secondary breaker larger than indicated by column M may be required.

▲ Short-circuit currents are calculated with impedances shown applying to liquid immersed transformers only. Refer to Table 17 for ventilated dry type impedances.

TABLE 25-C.

Transformer Rating 3-ph KVA and Impedance Per Cent	Maximum Short Circuit KVA Available from Primary System	Normal Load Continu- ous Current Amperes	Short-Circuit Current Total RMS Symmetrical Amperes			Minimum Frame Size Air Circuit Breaker Recommended			
			Transformer Alone	50% Motor Load	Combined	M*	C	I	S
						Main Breaker	Cascaded Feeder	Feeder with Instant. Trip	Feeder with Selective Trip
112.5 4.5% ▲	50,000	312	6,580	600	7,180	K-600	K-225	K-225	K-225
	100,000		6,740		7,340				
	150,000		6,820		7,420				
	250,000		6,880		7,480				
	500,000		6,920		7,520				
150 4.5% ▲	50,000	416	7,520	800	8,320	K-600	K-225	K-225	K-225
	100,000		7,720		8,520				
	150,000		7,760		8,560				
	250,000		7,880		8,680				
	500,000		8,000		8,800				
225 4.5% ▲	50,000	625	12,640	1200	13,840	K-1600	K-225	K-225	K-600
	100,000		13,120		14,320				
	150,000		13,360		14,560				
	250,000		13,600		14,800				
	500,000		13,760		14,960				
300 5.0%	50,000	834	14,880	1700	16,580	K-1600	K-225	K-225	K-600
	100,000		15,680		17,380				
	150,000		16,000		17,700				
	250,000		16,240		17,940				
	500,000		16,400		18,100				
500 5.0%	50,000	1388	23,120	2800	25,920	K-1600	K-225	K-600	K-1600
	100,000		25,200		28,000				
	150,000		26,000		28,800				
	250,000		26,640		29,440				
	500,000		27,200		30,000				
750 5.75%	50,000	2080	28,640	4200	32,840	K-3000	K-225	K-600	K-1600
	100,000		32,000		36,200				
	150,000		33,360		37,560				
	250,000		34,400		38,600				
	500,000		35,280		39,480				
1000 5.75%	50,000	2780	35,840	5600	41,440	K-4000	K-225	K-1600	K-3000
	100,000		41,120		46,720		K-225		
	150,000		43,360		48,960		K-600		
	250,000		45,200		50,800		K-600		
	500,000		46,720		52,320		K-600		

* The transformer main secondary breakers are in most cases determined by continuous current instead of fault current. For this reason breakers in the M column are usually larger than those listed in the I column. The values listed in the M column allow a breaker continuous rating approximately 25% above the transformer self-cooled full load current. If the transformer has a fan cooled rating a main secondary breaker larger than indicated by column M may be required.

▲ Short-circuit currents are calculated with impedances shown applying to liquid immersed transformers only. Refer to Table 17 for ventilated dry type impedances.

GUIDE SPECIFICATIONS FOR SECONDARY UNIT SUBSTATIONS

NOTE: Blue color and italics denotes information to be supplied by purchaser regarding either:

- Choice of alternates
- Addition of optional features
- Specific information

SCOPE

These specifications cover a complete (indoor) (outdoor) secondary unit substation from the incoming line terminals to the outgoing feeder terminals.

SECTIONS

The substation will have the following sections:

1. Incoming line section with () incoming primary circuit(s).
2. Transforming section consisting of () transformer.
3. Outgoing section which will provide for () outgoing feeders provided with low-voltage power circuit breaker(s).

GENERAL ARRANGEMENT

The accompanying sketch No. _____ indicates orientation of equipment only, not construction details.

RATINGS

The ratings of the substation will be:

Self-Cooled rating	kva
Fan-Cooled rating	kva
Frequency	60 cycles
Number of Phases	3
() incoming (3) (4)-wire circuit(s)	kv
() outgoing (3) (4)-wire circuit(s)	volts

INCOMING LINE SECTION(S)

(2-Position On-Off) (3-Position, Line 1-Off-Line 2) (Fused) (Unfused) Air Interrupter Switch(es)

This section shall consist of a floor-mounted, formed welded metal enclosure (close coupled) (separately proofed and throat connected) to the transformer section and equipped with:

- 1—3-pole, 2-position, gang-operated load interrupter switch, type HPL-C rated 600 amperes, _____ KV, interrupting capacity 600 amperes.
- 1—3-pole, 2-position selector switch interlocked and in series with the air interrupter switch.
- 3—Power fuses, current limiting type CL _____ KV, _____ amperes, continuous. To be located between the switch and the transformer. The fuse door to be interlocked with the switch handle to prevent opening when the switch is in the closed position.
- 3—Lightning arresters rated (6) (15) KV.

size cable to enter from (above) (below) and terminate in _____ clamp-type lugs per phase or (1-3 C) (2-3 C) (3-1 C) (6-1 C) pothead(s). Pothead(s) to be provided with _____ fitting for cables with the following specifications: _____ KV size, _____ insulation, _____ O.D. over insulation, _____ O.D. conductor, _____ O.D. overall.

Liquid (Interrupter) (Disconnect) Switch(es)

This section shall consist of non-fused, oil-insulated, load interrupter switch, mounted on transformer tank. This switch to be 3-pole (2) (3)-position device rated _____ amperes continuous at _____ kv.

This section shall consist of non-fused, oil-insulated, disconnect switch, mounted on transformer tank. The switch shall be capable of breaking transformer over-current and the switch shall be of the type designed for this operation. This switch to be 3-pole, (2) (3)-position device rated _____ amperes continuous at _____ kv.

size cable to enter from (above) (below) and terminate in (1-3 C) (2-3 C) (3-1 C) (6-1 C) pothead(s). Pothead(s) to be provided with _____ fitting for cables

with the following specifications: _____ KV size, _____ insulation, _____ O.D. over insulation, _____ O.D. conductor, _____ O.D. overall.

Oil Fuse Cutouts

This section shall consist of 3-gang-operated oil fuse cutouts, mounted in an air-filled terminal chamber directly connected to the transformer tank wall. Cutouts are to be 2-position and rated _____ amperes continuous at _____ kv.

size cable to enter from (above) (below) and terminate in _____ clamp-type lugs per phase or (1-3 C) (2-3 C) (3-1 C) (6-1 C) pothead(s). Pothead(s) to be provided with _____ fitting for cables with the following specifications: _____ KV size, _____ insulation, _____ O.D. over insulation, _____ O.D. conductor, _____ O.D. overall.

Air Terminal Chamber

This section shall consist of a full-height air terminal chamber directly connected to the high-voltage side of the transformer. It shall be rated (4.8) (13.8) KV.

size cable to enter from (above) (below) and terminate in _____ clamp-type lugs per phase or (1-3 C) (2-3 C) (3-1 C) (6-1 C) pothead(s). Pothead(s) to be provided with _____ fitting for cables with the following specifications: _____ KV size, _____ insulation, _____ O.D. over insulation, _____ O.D. conductor, _____ O.D. overall.

Metal-Clad Switchgear

- 1—Metal-clad switchgear unit.
- 1—(4) (6) (2) (13.8) kv air circuit breaker, _____ amp, 3-pole, electrically-operated stored-energy.
- 1—Set of insulated main bus, _____ amp.
- 3—Current transformers, _____ -5 ratio.
- 3—Overcurrent relays, instantaneous and time over-current.
- 1—Breaker control switch with red and green indicating lights.
- 1—Ammeter, 0-_____ scale.
- 1—Ammeter transfer switch.
- 1—Voltmeter _____
- 1—Voltmeter switch _____
- 1—Voltmeter switch _____
- 1—Watt-hour meter, _____ element
- 3—Directional overcurrent relays (with) (without) instantaneous trip.
- 3—Drawout potential transformers _____ -120 _____ volt ratio.

size cable to enter from (above) (below) and terminate in _____ clamp-type lugs per phase or (1-3 C) (2-3 C) (3-1 C) (6-1 C) pothead(s). Pothead(s) to be provided with _____ fitting for cables with the following specifications: _____ KV size, _____ insulation, _____ O.D. over insulation, _____ O.D. conductor, _____ O.D. overall.

TRANSFORMER SECTION

Ventilated-Dry Type—(60) (150) kv

Transformer shall be a ventilated-dry type, metal-enclosed indoor construction, 3-phase, 60 cycles, (self-cooled) (fan-cooled) with a temperature rating not to exceed a 150 C rise above 30 C average ambient. Rated _____ KVA, with a delta primary of _____ KV and a secondary of _____ volts.

Provide four (4) approximately 2½ full capacity taps in the high-voltage winding, two above and two below normal, brought out through studs, complete with bolted flexible links for deenergized tap-changing operation, made accessible through a removable panel on the transformer enclosure.

Transformer base construction to be of the fabricated type and suitable for using rollers or skidding in any direction.

Transformer to be factory tested as prescribed by ASA and NEMA Standards. All NEMA standards accessories are to be provided.

Necessary winding-temperature equipment for control of fans.

Shall have provision for future fan cooling.

Gas-Filled Sealed-Dry Type—AA

Transformer shall be sealed-dry type, gas-filled, 3-phase, 60 cycles, self-cooled, with a temperature rating not to exceed a 150 C rise above a 30 C average ambient.

Rated _____ KVA, with a delta primary of _____ KV and a secondary of _____ volts (Delta) (Wye).

Provide four (4) approximately 2½% full capacity taps in the high-voltage winding, two above and two below normal, brought out to an externally-operated, deenergized tap changer. Tap changer cover to be capable of being bolted in any tap position.

Transformer base construction to be of the fabricated type and suitable for using rollers or skidding in any direction.

Transformer to be factory tested as prescribed by ASA and NEMA Standards. All NEMA standard accessories are to be provided.

Liquid-Immersed Types (Oil) (Askarel)—(OA) (OA SA)

Transformer shall be (Oil) (Askarel) insulated, 3-phase, 60 cycles, (self-cooled) (fan-cooled,) with a temperature rating not to exceed a 65 C rise above 30 C average ambient.

Rated _____ KVA, with delta primary of _____ KV and a secondary of _____ volts (Delta) (Wye).

Provide four (4) approximately 2½% full capacity taps in the high-voltage winding, two above and two below normal, brought out to an externally-operated, deenergized tap changer. Tap changer handle to be capable of being locked in any tap position.

Transformer base construction to be of the fabricated type and suitable for using rollers or skidding in any direction.

Necessary winding-temperature equipment for control of fans.

Shall have provision for future fan cooling.

OUTGOING SECTION

This section shall consist of one metal-enclosed (indoor) (outdoor) switchgear assembly, drawout type, rated 600 v a-c and arranged for _____ volt service on a _____ volt 3-phase (3) (4)-wire (grounded) (ungrounded) system. It shall be designed, factory assembled and tested in accordance with the latest applicable AIEE, NEMA and ASA standards.

SWITCHBOARD (indoor) (outdoor)

Switchboard shall consist of sufficient vertical frames to house the number of circuits specified below, with a minimum number of empty spaces remaining. Each individual frame shall be divided into a front breaker section and a rear bus section isolated by steel panels. In addition, each circuit-breaker compartment shall be completely isolated from adjacent compartment by steel panels. Finish shall be light gray baked synthetic enamel.

SWITCHBOARD (indoor only)

Switchboard shall be of the walk-in weatherproof type with gasketing throughout. Sufficient filtered louvers and screened vents shall be provided to afford adequate ventilation. Sufficient strip heaters shall also be included to prevent condensation. Interior lighting and convenience outlets shall be furnished in the aisle space. A manually-operated lifting device running the full length of the walk-in aisle shall be provided for easy handling of breakers. Suitable undercoating shall be applied to prevent corrosion. Finish shall be dark gray baked synthetic enamel.

BUS

A single-main bus shall extend through all frames of the switchboard, with interconnections to the circuit breakers in each individual frame. The bus shall be completely silver-plated aluminum and of the same current rating as the main circuit breaker or the power source. It shall be braced to withstand stresses resulting from the maximum short-circuit current available, minimum bracing to be 42,000 amp symmetrical.

DISCONNECTING DEVICES & DRAWOUT MECHANISM

The breakers shall be of the drawout type, provided with self-aligning disconnecting devices, with the disconnecting fingers mounted on the breaker for ease of maintenance. The drawout mechanism shall hold the circuit breaker rigidly in the fully connected, test and fully disconnected positions. Interlocks shall be provided that will prevent moving the circuit breaker from the fully connected, test or fully disconnected positions, unless the breaker is open. Interlocks shall prevent closing the breaker between any of these positions. Provision shall be made for padlocking the breaker open and in any of the positions noted above.

CIRCUIT BREAKERS

Air circuit breakers shall be _____ pole, each pole equipped with a direct-acting dual-magnetic overcurrent tripping device providing adjustable overcurrent and instantaneous short-circuit protection. All (manually) (electrically) operated breakers shall be equipped with (manual) (motor) charged stored-energy closing mechanism to provide quick-make operation.

The drawout mechanism shall be designed so that the breaker can be racked to any position without opening the door, for maximum protection to operating personnel.

A hasp on the breaker escutcheon shall be provided that can receive up to three padlocks when the breaker is in the open position, positively preventing unauthorized closing or racking of the breaker. A manual trip button and external breaker position indicator shall be provided. The Following Equipment Shall Be Supplied:

_____ main secondary breaker(s), _____ amp maximum continuous current, _____ amp interrupting capacity at _____ v ac (manually) (electrically) operated.

_____ tie breaker(s), _____ amp maximum continuous current, _____ amp interrupting capacity at _____ v ac (manually) (electrically) operated.

_____ feeder breaker(s), _____ amp maximum continuous current, _____ amp interrupting capacity at _____ v ac (manually) (electrically) operated.

_____ feeder breaker(s), _____ amp maximum continuous current, _____ amp interrupting capacity at _____ v ac (manually) (electrically) operated.

_____ space(s) for future breaker(s), _____ maximum continuous current, _____ amp interrupting capacity at _____ v ac (manually) (electrically) operated.

_____ control-power transformer(s) for electrically operated breaker(s).

Transformer Secondary Metering

_____ voltmeter(s), with 3-phase transfer switch.

_____ ammeter(s), with switch.

_____ watt-hour meter(s), (two) (three) element, (with) (without) demand attachment.

_____ current transformer(s), _____ or suitable rating.

_____ ammeter with 3-phase transfer switch.

_____ potential transformer(s), suitable rating.

Feeder Metering

_____ ammeter with 3-phase transfer switch.

_____ watt-hour meter(s), (two) (three) element.

_____ current transformer(s), _____ or suitable rating.

BUS DUCT Switchboard To

Bus shall be non-segregated phase, metal-enclosed (indoor) (outdoor), rated 600 volts _____ amperes, 3 phase, (3)(4) wire, 60 cycles and shall consist of bare conductors, insulated supports and housing.