



Control Transformers Machine Tool Transformer Disconnects

CONTENTS

Description	Class	Pages
General	9070	2-3
Application Data	9070	4
Selection Guide	9070	5
Dimensions	9070	6
Transformer Disconnects	9070	7



www.ElectricalPartManuals.com



SQUARE D COMPANY



CLASS	9070
PAGE	1
DECEMBER, 1966	

CONTROL CIRCUIT TRANSFORMERS

50 Hertz may be applied to 60 Hertz transformer at reduced VA rating shown. Do not apply 25 Hertz to transformer rated at 60 Hertz. Windings of 25 Hertz transformers differ from 50 and 60 Hertz transformers.

Continuous VA			Standard Voltage Transformers			
			Open Type		General Purpose Enclosure NEMA Type 1	
60 Hertz	50 Hertz	25 Hertz	Type	Price	Type	Price
50	35	EO-1	\$ 12.	EG-1	\$ 18.
100	70	50	EO-2	14.	EG-2	22.
150	120	75	EO-3	16.	EG-3	24.
300	240	150	EO-4	29.	EG-4	37.
500	400	200	EO-5	38.	EG-5	54.
750	500	350	EO-6	58.	EG-6	74.
1000	1000	500	EO-7	65.	EG-7	81.
1500	1500	750	EO-8	81.	EG-8	107.
2000	2000	1000	EO-9	112.	EG-9	138.

STANDARD VOLTAGES

60 Hertz	50 Hertz	25 Hertz
240-480/120	230-460/115	230-460/115
230-460/115	220-440/110	575/115
220-440/110	575/115	230-460/24
600/120	550/110	
575/115		
550/110		
240-480/24		

NON-STANDARD VOLTAGES

Description	Price Addition
Non-standard single primary and/or single secondary voltage rating.....	\$5.00
Non-standard dual voltage primary with any single voltage secondary rating.....	7.00

SECONDARY CIRCUIT PROTECTION

Class 9070 Type AP-1 and AP-2 fuse block and bracket assemblies are available for use on Types EO-1 through EO-4 transformers. In the case of open type transformers, these assemblies are furnished as separate items to provide

maximum flexibility with minimum stocking. Factory mounted assemblies are only available on enclosed type transformers.

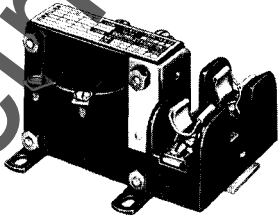
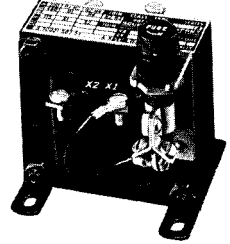
<p>The Type AP-1 includes a fuse block for an NEC (30 amp., 250 Volts max.) fuse and a bracket which is held in place by a screw on the transformer. Two Type AP-1 assemblies can be mounted on each transformer.</p>  <p style="text-align: center;">Type EO-1 Transformer with Type AP-1 Fuse Block Installed</p> <table border="1" style="margin-left: auto; margin-right: auto;"> <thead> <tr> <th>Type</th> <th>Price</th> </tr> </thead> <tbody> <tr> <td>AP-1</td> <td style="text-align: right;">\$3.00</td> </tr> </tbody> </table>	Type	Price	AP-1	\$3.00	<p>The Type AP-2 fuse block has been designed especially for use with the Type E transformer. It consists of a fuse holder for a 1 1/4" x 1/4" fuse (30 amp., 250 Volts max.), a bracket for holding the assembly on the transformer and a lead assembly for connecting the fuse to one of the transformer terminals. The bracket is furnished with a tapped hole and is held in position by one of the screws on the transformer. Two Type AP-2 assemblies can be mounted on each transformer.</p>  <p style="text-align: center;">Type EO-1 Transformer with Type AP-2 Fuse Block Installed</p> <table border="1" style="margin-left: auto; margin-right: auto;"> <thead> <tr> <th>Type</th> <th>Price</th> </tr> </thead> <tbody> <tr> <td>AP-2</td> <td style="text-align: right;">3.00</td> </tr> </tbody> </table>	Type	Price	AP-2	3.00
Type	Price								
AP-1	\$3.00								
Type	Price								
AP-2	3.00								

FACTORY MOUNTED FUSE ASSEMBLIES FOR ENCLOSED TRANSFORMERS

Description	Form	Price Addition
NEC fuse block, AP-1, (30 A., 250 V.) mounted in transformer enclosure (NEMA Type 1 only.)		
One fuse block.....	F2	\$4.00
Two fuse blocks.....	F3	8.00

ORDERING INFORMATION REQUIRED

Class, type, VA rating, voltage, and fuse block or form number, if any.



CONTROL CIRCUIT TRANSFORMERS

APPLICATION DATA

APPLICATION

Control circuit transformers are widely used to reduce control circuit voltages for many reasons, the most important of which are as follows:

1. Operator safety is increased by the use of a low voltage at the control stations and other pilot devices. Also, because of the reduced potential, there is less chance of a fault occurring between lines of the control circuit wiring or to ground.
2. Simplifies voltage changeover of complicated control panels — the transformer is replaced, or, in the case of a transformer with a dual primary, the primary windings are reconnected instead of changing the magnet coil of each device.

REGULATION

Class 9070 Type E control circuit transformers are designed specifically for use with industrial control equipment. Devices such as starters, contactors, relays, timers and solenoids are characterized by high, momentary inrush currents to the magnet operating coil during the pickup period. These devices require a transformer with excellent voltage regulation to keep the voltage drop in the transformer to a minimum when high inrush currents are encountered. Otherwise the voltage applied to the coil will be too low to provide satisfactory pickup.

NEMA standards require magnetic devices such as starters to operate satisfactorily at 85% of rated voltage. Allowing for a line voltage of 10% below rated voltage, the voltage drop of the transformer is limited to 5% to insure continued satisfactory operation. Type E transformers are de-

SELECTION OF TRANSFORMERS

Selection of a proper control circuit transformer must be made from a determination of the maximum inrush VA and the maximum continuous VA to which it is subjected. This data can be determined as follows:

1. Determine inrush and sealed VA of all coils to be used.
2. Determine maximum sealed VA load on the transformer.
3. Determine the maximum inrush VA load on the transformer at 100 per cent secondary voltage. Add this value vectorially to any sealed VA present at time inrush occurs.
4. Calculate the power factor of the VA load obtained in (3). Actual coil power factors should be used. If this value is unknown, an inrush power factor of 30% may be assumed.
5. Select a transformer:
 - (a) With a continuous VA rating equal to or greater than the value obtained in (2) and
 - (b) Whose maximum inrush VA from (3) at the load power factor calculated in (4) falls on or below the corresponding curve in Fig. 1-5 for the transformer selected in (5a).

signed with windings of low impedance to provide this excellent voltage regulation — see regulation curves on pages 3 and 4. Good transformer regulation characteristics are essential in order that transformer selection can be made on the basis of continuous VA rating which is always the most economical choice.

CONSTRUCTION

Type E transformers are compact in design and built for control panel mounting. Oblong mounting holes, directly accessible from the front, are provided to simplify mounting and alignment of the transformer on the panel.

Screw type terminals are accessible from the front and eliminate terminal boards or splicing usually required with flexible leads. Each terminal is clearly marked and correct connections for the voltage desired are shown on the nameplate which is mounted on top of the transformer for easy reference. Transformer coils are precision layer-wound with insulating paper between layers of wire and are well insulated between primary and secondary, and to ground. Maximum temperature rise is limited to 55° C. Windings are of additive polarity.

ENCLOSURES

NEMA 1 general purpose enclosures are intended to prevent accidental contact with live parts and are suitable for general indoor use where normal atmospheric conditions prevail. Enclosures are constructed of sheet steel finished in a standard gray enamel. Types EG-1 through EG-4 enclosures are furnished with slip-on covers. Enclosures for Types EG-5 through EG-7 are provided with a hinged cover.

Type E transformers may be used with Square D Class 8502 contactors and Class 8536 starters as follows:

TYPES A THRU G CONTACTORS AND STARTERS

Class 9070 Type	Starter or Contactor NEMA Size	
	60/50 Hertz	25/30 Hertz
EO-1	00, 0 and 1
EO-2	2	0 and 1
EO-3	3 and 4	2
EO-4	3 and 4

NOTE: Standard engineering practice for Size 5 and larger contactors is to use a 50 VA transformer and a control relay.

TYPE S

CONTACTORS AND STARTERS

Class 9070 Type	NEMA Size	Type of Device	No. of Poles	Auxiliary Units
EO-1	0 and 1	Non-Reversing	1-3	W/O Timer — 3 External Interlocks W/Timer — 2 External Interlocks
EO-2	0 and 1	Non-Reversing	4 and 5	With or Without External Interlock or Timer
		Reversing	1-5	With and Without Any Attachment
EO-3	2	Non-Reversing & Reversing	1-5	With and Without Any Attachment
		Non-Reversing & Reversing	3	With and Without Any Attachment

*For Size 3 in NEMA Types 1, 4 or 12 enclosures, use 9070 GFT-3 transformer kit. Refer to Class 9070 Page 11 for application information and pricing.



REGULATION CURVES

These curves indicate **maximum permissible, inrush loads** (volt-amperes at 100% secondary voltage) which, if applied to the transformer secondary, will not cause the secondary voltage to drop below 85% of rated voltage when the primary voltage has been reduced to 90% of rated voltage.

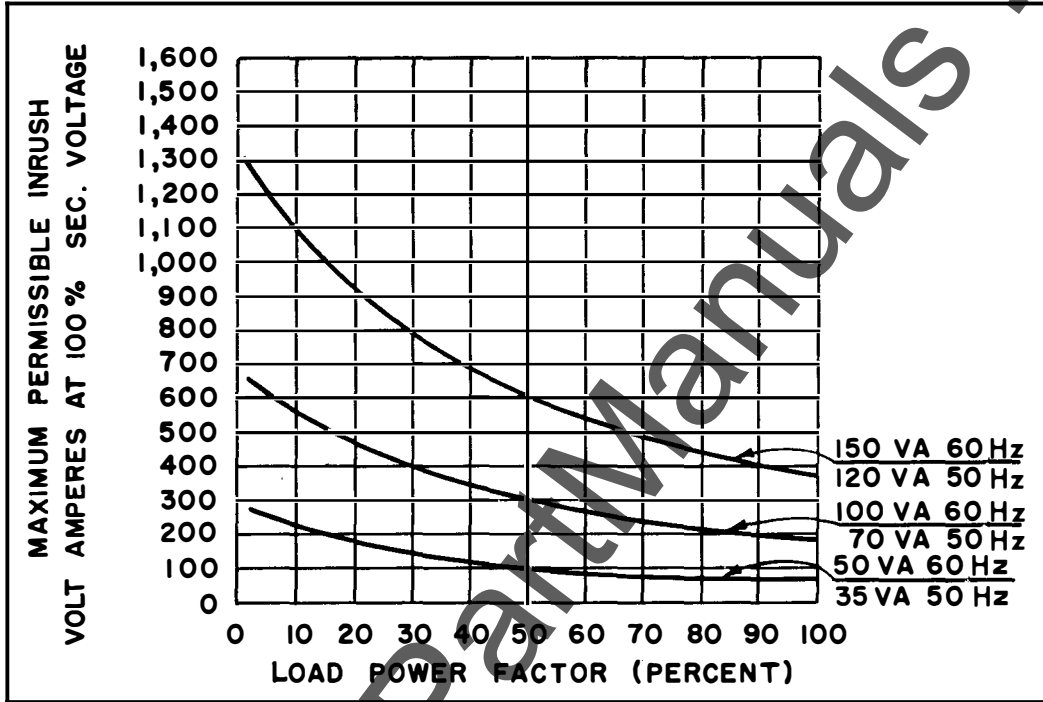

Fig. 1 — 60/50 Hertz

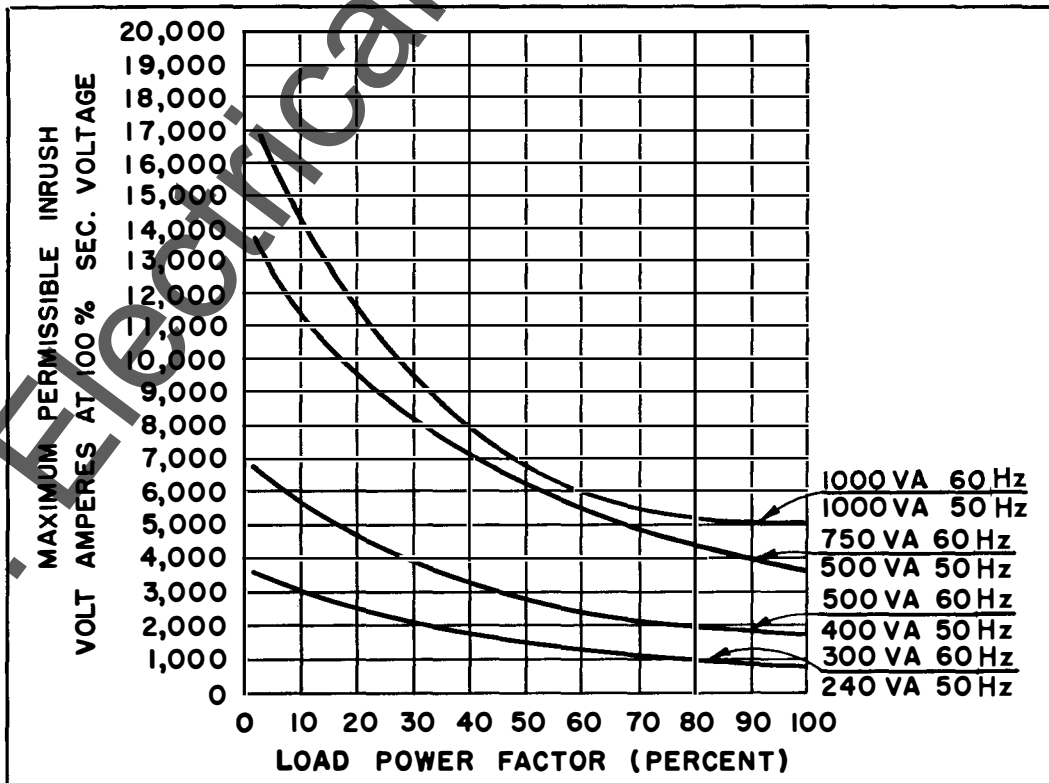

Fig. 2 — 60/50 Hertz



REGULATION CURVES (Continued)

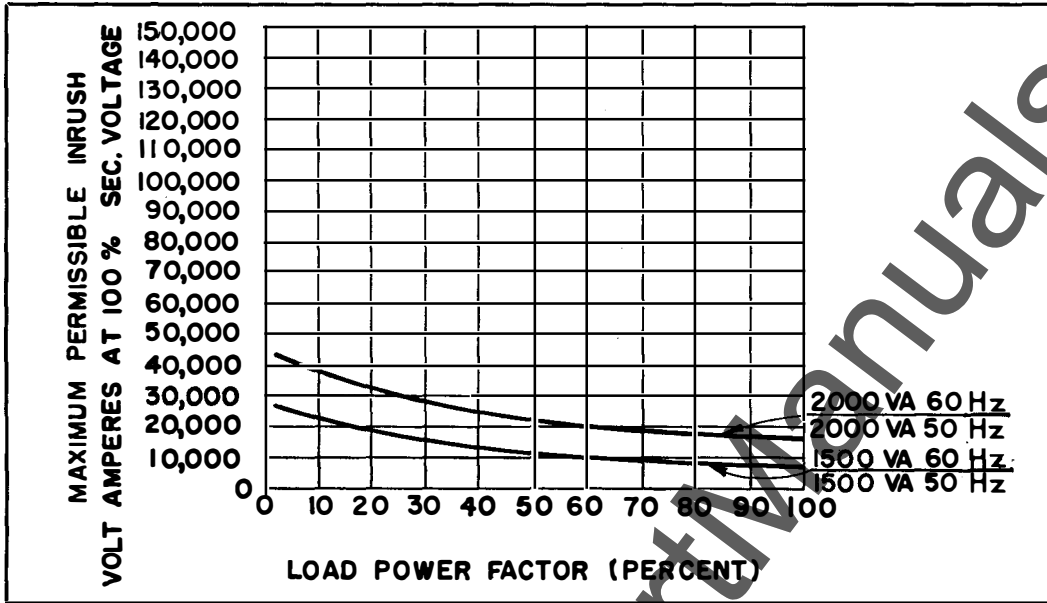
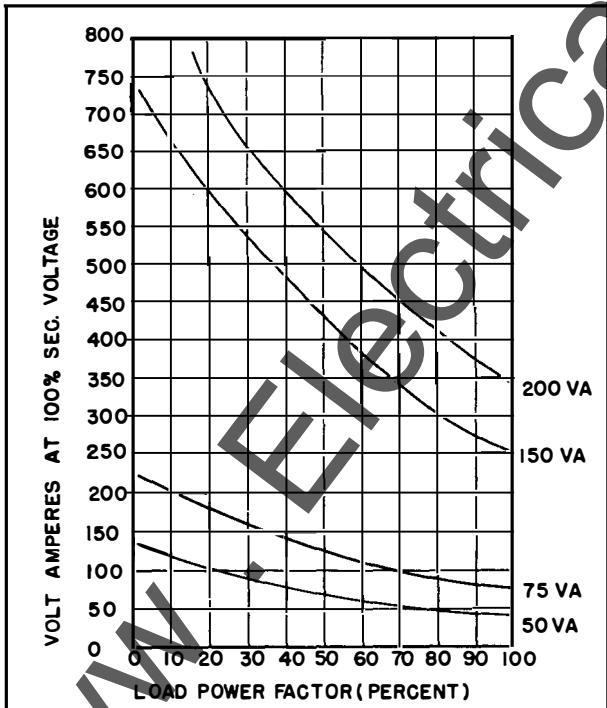

Fig. 3 — 60/50 Hertz



830021 - 015

Fig. 4 — 25, 30 Hertz

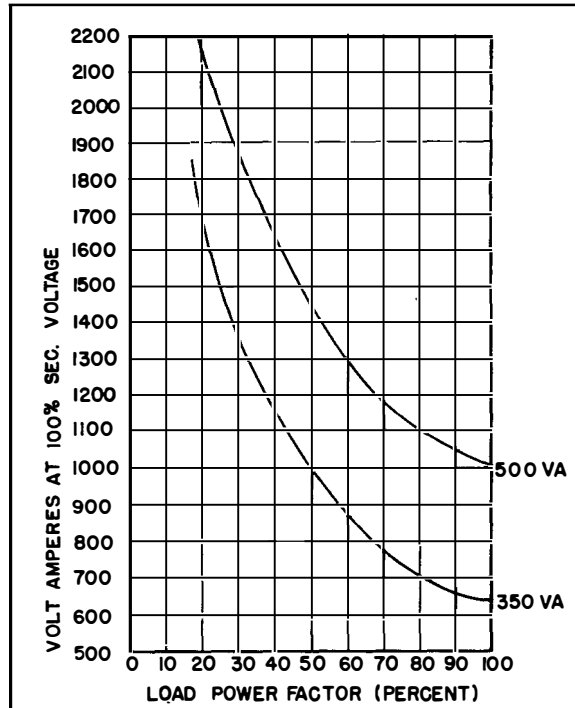
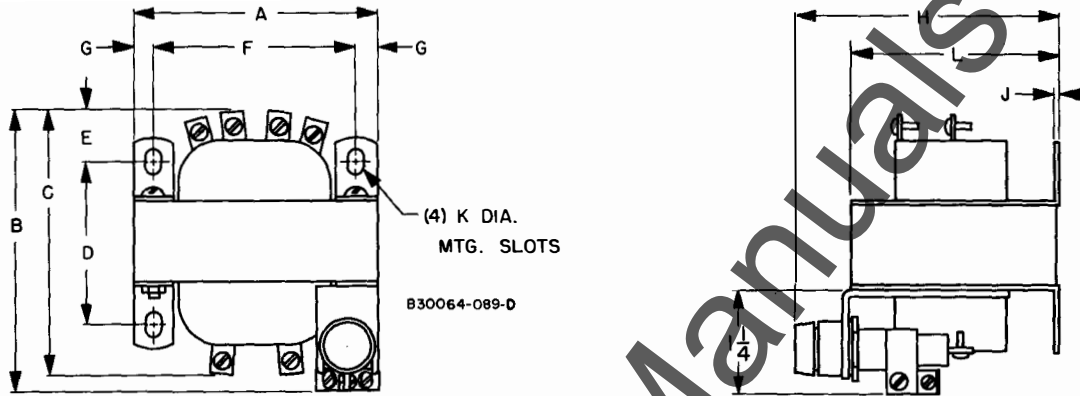

Fig. 5 — 25/30 Hertz



CONTROL CIRCUIT TRANSFORMERS

APPROXIMATE DIMENSIONS AND SHIPPING WEIGHTS FOR STANDARD VOLTAGE TRANSFORMERS CLASS 9070 TYPE E TRANSFORMERS OPEN TYPE



Type	Weight in Pounds	Dimensions										
		A†	B*	C	D	E	F	G	H*	J	K	L
EO-1	3	3	3 ¹ / ₂	3 ¹ / ₄	2	5 ¹ / ₂	2 ¹ / ₂	1 ¹ / ₄	3 ¹ / ₂	.083	1 ³ / ₄ x 2 ¹ / ₄	2 ³ / ₈
EO-2	5	3 ³ / ₈	4 ¹ / ₂	4	2 ³ / ₈	1 ³ / ₈	2 ¹ / ₂	9 ¹ / ₂	3 ¹ / ₂	.083	1 ³ / ₄ x 2 ¹ / ₄	2 ⁷ / ₈
EO-3	8	3 ³ / ₄	4 ² / ₂	4 ³ / ₄	2 ⁷ / ₈	1 ⁵ / ₈	3 ¹ / ₈	5 ¹ / ₈	3 ³ / ₈	.083	1 ³ / ₄ x 2 ¹ / ₄	3 ³ / ₈
EO-4	12	4 ¹ / ₂	5 ⁵ / ₂	5 ⁵ / ₈	3 ¹ / ₄	1 ¹ / ₈	3 ³ / ₄	3 ³ / ₈	4 ¹ / ₂	7 ¹ / ₄	1 ⁵ / ₄ x 2 ¹ / ₄	3 ¹ / ₂
EO-5	18	5 ¹ / ₄	...	6	4 ³ / ₈	1 ³ / ₈	4 ³ / ₈	7 ¹ / ₈	...	1 ¹ / ₈	5 ¹ / ₈ x 1 ¹ / ₈	4 ⁵ / ₈
EO-6	28	5 ¹ / ₄	...	7 ⁵ / ₈	5 ³ / ₈	1 ⁵ / ₈	4 ³ / ₈	7 ¹ / ₈	...	3 ¹ / ₂	5 ¹ / ₈ x 1 ¹ / ₈	4 ⁵ / ₈
EO-7 Series B	33	6 ⁷ / ₈	...	6 ³ / ₈	4	1 ³ / ₈	5 ⁵ / ₈	2 ⁵ / ₂	...	1 ¹ / ₈	5 ¹ / ₈ x 1 ¹ / ₈	6 ¹ / ₈
EO-8	48	7 ¹ / ₈	...	8	5 ¹ / ₂	1 ¹ / ₄	5 ¹ / ₂	1 ³ / ₈	...	1 ¹ / ₈	7 ¹ / ₈ x 1 ¹ / ₈	6 ⁵ / ₈
EO-9	54	7 ¹ / ₈	...	9 ¹ / ₈	5 ⁷ / ₈	1 ⁵ / ₈	5 ¹ / ₂	1 ³ / ₈	...	1 ¹ / ₈	7 ¹ / ₈ x 1 ¹ / ₈	6 ¹ / ₂

†Add 1³/₄" to dimension "A" if Type AP-1 fuse block used.
 *Type AP-2 fuse block shown. Use dimension "C" and "L" if Type AP-1 used.

ENCLOSED — NEMA TYPE 1

Type	Weight in Pounds	Dimensions — Diagram 1							
		A	B	C	D	E	F	G	H
EG-1	7	4 ¹ / ₁₆	9 ¹ / ₄	7 ⁷ / ₈	3 ³ / ₂	1 ¹ / ₁₆	1 ¹ / ₁₆	1/2-3/4	4 ¹ / ₈
EG-2	12	6 ¹ / ₁₆	11 ¹ / ₂	9 ⁷ / ₈	4 ¹ / ₂	1 ¹ / ₁₆	1	1/2-3/4	5 ¹ / ₂
EG-3	15								
EG-4	19								

Diagram 1

Type	Weight in Pounds	Dimensions — Diagram 2					
		A	B	C	D	E	F
EG-5	31						
EG-6	41	9 ¹ / ₈	13 ¹ / ₈	7 ⁵ / ₈	7	11	5 ¹ / ₈
EG-7	46						
EG-8	70	10 ¹ / ₈	15 ⁵ / ₈	8 ¹ / ₂	7 ¹ / ₂	13	7 ¹ / ₈
EG-9	76						

Diagram 2

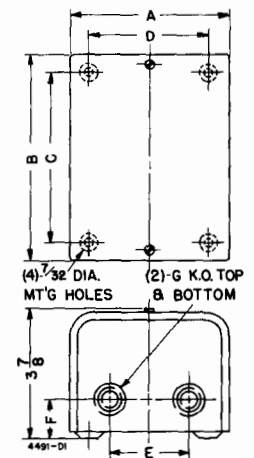
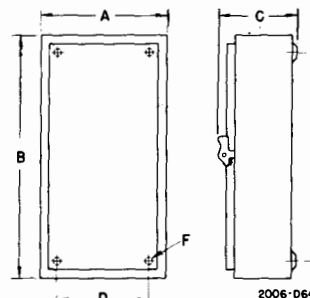

Above dimensions and weights also apply to Forms F2 and F3.
 Types EG-5 through EG-9 have two 1/2"-3/4" knockouts in top and bottom and one 1/2" knockout near top and bottom on each side.

Dimensions are in inches.



CLASS	9070
PAGE	11
DECEMBER, 1966	

TYPE GO CONTROL CIRCUIT TRANSFORMERS

STANDARD VOLTAGE TRANSFORMERS WITH FUSE BLOCK ELEVATOR KIT FOR TYPE S CLASS 8538 AND 8539 COMBINATION STARTERS

Continuous VA		Open Type	
60 Hertz	50 Hertz	Type	Price
100	70	GO-2	\$20.
150	120	GO-3	25.
300	240	GO-4	40.

STANDARD VOLTAGES

60 Hertz	50 Hertz
240-480/120	230-460/115
230-460/115	220-440/110
220-440/110	575/115
600/120	550/110
575/115	
550/110	
240-480/24	

NON-STANDARD VOLTAGES

Description	Price Addition
Non-standard single primary and/or single secondary voltage rating.....	\$5.00
Non-standard dual voltage primary with any single voltage secondary rating.....	7.00

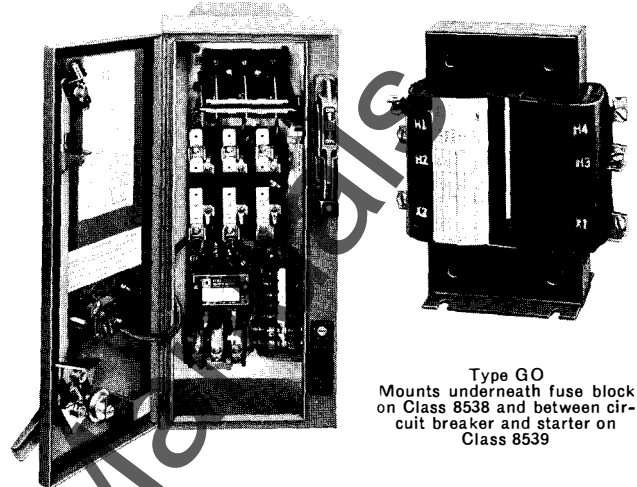

Type GO
 Mounts underneath fuse block on Class 8538 and between circuit breaker and starter on Class 8539

APPLICATION DATA

The Type GO transformer is designed for factory or field installation in Class 8538 and 8539 Type S combination starters. In Class 8538 fusible combination starters, the transformer is mounted underneath the fuse block. A fuse block elevator kit is furnished with each transformer to

permit field installation. In Class 8539 devices, the transformer is mounted on end and the fuse block supports are not used. Holes are provided in the combination starter panel for mounting the Type GO transformer and supports where necessary.

CONTROL TRANSFORMER SELECTION GUIDE

Class	Type S Size	Enclosure Type	Form	Class 9070 Type
8538 8539	0 and 1	1, 4, 12	FT (Standard — 50 VA transformer).....	EO-1
			FT-11 (100 Watt Extra Capacity).....	GO-3
			FT-12 (200 Watt Extra Capacity).....	GO-4
8538 8539	2	1, 4, 12	FT (Standard — 100 VA transformer).....	GO-2
			FT-11 (100 Watt Extra Capacity).....	GO-4
			FT-12 (200 Watt Extra Capacity).....	GO-4
8538 8539	3	1, 4, 12	FT (Standard — 150 VA Transformer).....	EO-3
			FT-11 (100 Watt Extra Capacity).....	EO-4
			FT-12 (200 Watt Extra Capacity).....	EO-5
8502 8536	3	1, 4, 12	FT (Standard — 150 VA Transformer).....	GFT-3

Type	Price
GFT-3	\$50.

The GFT-3 transformer kit is designed to be used with Class 8502 and 8536 Type S Size 3 contactors and starters in NEMA 1, 4 and 12 enclosures. The kit includes a Class 9070 GO-3 transformer, Class 9070 AP-1 fuse block with proper fuse; necessary wiring is included and all the components are mounted on the bracket.

Class 9070 Type	Dimensions				
	Max. A	B	C	D	E
GO-2	5 $\frac{3}{8}$	2 $\frac{1}{2}$	5 $\frac{7}{8}$	2	1 $\frac{5}{8}$
GO-3	5 $\frac{1}{2}$	2 $\frac{1}{2}$	5 $\frac{7}{8}$	2 $\frac{3}{8}$	2
GO-4	5 $\frac{7}{8}$	2 $\frac{1}{2}$	5 $\frac{7}{8}$	2 $\frac{3}{8}$	2 $\frac{1}{2}$

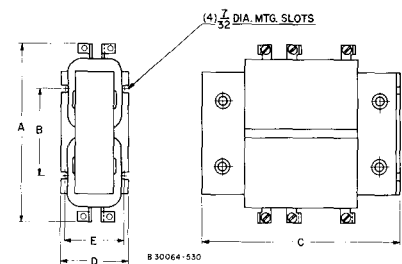

ORDERING INFORMATION REQUIRED

Class, Type, VA rating and Voltages.



AC TO DC SOLID STATE CONVERTER

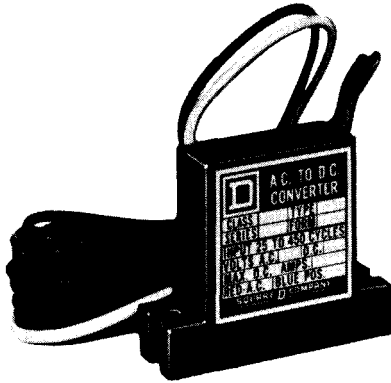

Class 9070 Type HO

The Class 9070 Type HO solid state converter is a device that converts an ac input voltage to a dc output voltage for dc loads. It can be used with devices such as dc relays, timers, contactors and starters with dc control circuits, as well as other devices where energization with dc is desirable. The converter will permit the use of such devices in systems employing voltage sources of 25 through 450 hertz without requiring any modification to the devices themselves. A typical application would be that of controlling lighting or power loads in areas where the magnet hum of ac devices may be objectionable, such as hospitals and schools.

25-450 HERTZ		CLASS 9070		240 VOLTS MAX.	
AC Input	DC Output	Type	Price		
Volts	Volts Max. Amps.				
0—120	0—115 2	HO-1	\$21.		
121—240	116—230 1	HO-2	26.		

APPROXIMATE DIMENSIONS

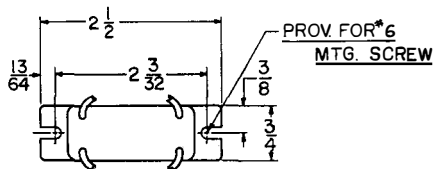

A30054-308-A

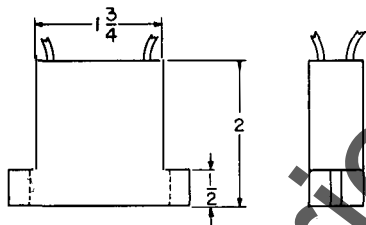

CONNECTION DIAGRAM

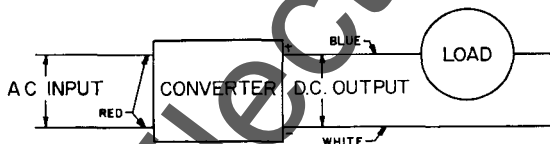

APPLICATION DATA

Ratings — The converter can be used with both resistive and inductive loads within the ratings shown in the table above. If used at reduced input voltage, the output amperage must not be exceeded.

Mounting — The device is completely encapsulated and provided with two mounting slots for #6-32 screws. It can be mounted by the mounting projections provided on the housing or it can be mounted to an adaptor bracket which permits its use with the Square D terminal block mounting channel.

Terminations — Four color coded #16 stranded wire leads, two feet long, are provided for circuit connection.

ORDERING INFORMATION REQUIRED

1—For panel mounting, order by class and type number.

2—For channel mounting, order converter and bracket 30501-276-01, price **\$0.40.**