



# Sorgel Dry Type Transformers Shielded Isolation Type 600 Volts and Below

INDOOR AND OUTDOOR — SINGLE PHASE AND THREE PHASE

## CONTENTS

Description	Page
General Application Data .....	2
Single Phase Transformers .....	3
Three Phase Transformers .....	4
Price List, Specifications Supplementary .....	S1



**SQUARE D COMPANY**



### Designed especially for:

- Data processing
- Computers
  - Programmable controllers
  - X-ray installations
- Sensitive instrumentation

Electrical noise immunity is a major concern in the design and installation of most modern electronic equipment. Products ranging from small solid state relays to major computer and numerical machine control installations all share a certain susceptibility to damage or malfunction as a result of transients and noise contained in the power supplied to them. This problem has been accentuated by the proliferation of electrical equipment usage, resulting in an ever increasing variety of stray signals, spikes and general "hash" into our electrical distribution systems. For this reason, electrostatic shields are commonly furnished between the primary and the secondary to attenuate some of the source line interference.

#### TIPS FOR SHIELDED ISOLATION TRANSFORMER SPECIFIERS AND SYSTEM DESIGNERS

**Know Your Power Requirements**—Shielded isolation transformers alone can do nothing to prevent equipment malfunction or damage resulting from long term voltage sags or "brown outs" originating at the utility service. If voltage variations beyond those tolerable to your equipment are likely to occur, either an uninterruptible power source or voltage regulation equipment may be necessary.

**Isolate Sensitive Branch Circuits**—Most noise problems originate within the user's plant from other equipment on his service. Whenever possible separate, isolated branch circuits should be used to supply sensitive loads.

**Evaluate Field Experience**—Manufacturers of computers and other sensitive equipment can add thousands of dollars to user expenditures by recommending an unwarranted degree of protection for their equipment. In addition, they can make themselves less competitive with other manufacturers who know they can specify standard equipment. Specifiers of isolation equipment should, therefore, obtain information on the sensitivity of the equipment to be protected.

#### DEFINITIONS . . .

**Attenuation**—(Also called suppression or rejection). The amount of signal loss in a system. In a device such as an isolation transformer, the degree of reduction of unwanted spikes and signals; usually expressed either as a voltage ratio or in decibels.

**Common mode noise**—Signals or spikes impressed from line-to-ground in a power distribution system.

**Decibel**—A logarithmic unit. The fundamental logarithmic unit is the bel, which is the common logarithm of the ratio of two values of power. The practical unit is the decibel (db), which is 1/10 bel.

$$\text{Number of decibels} = 10 \log_{10} \frac{W_2}{W_1}$$

$W_2$  and  $W_1$  = values of power expressed in the same units. A power ratio of 2 corresponds to 3 db. The total number of decibels is three times the number of times that 2 is contained as a factor in the ratio.

The decibel may also be used to express voltage or current ratios.

$$\text{Number of decibels} = 20 \log_{10} \frac{E_2}{E_1} \text{ or } 20 \log_{10} \frac{I_2}{I_1}$$

The factor 10 in the power equation is multiplied by 2, because the power varies as the square of the current or voltage ratio. Thus a voltage ratio of 2 corresponds to 6 db.

**Electrostatic shield**—Typically, one turn of a thin sheet of aluminum or copper, extending over the full width of the windings of a transformer, usually located between the primary and secondary windings.

**Isolation transformer**—Any transformer with windings which are electrically isolated from each other. Isolation transformers may or may not have electrostatic shields.

**Transient**—Any disturbance in the normal distribution power wave ranging from long term voltage dips and rises of several milliseconds to spikes and signals of less than one microsecond duration. Typical sources of transients and noise are switching surges on large distribution systems, lightning, arcing contacts on relays and contactors, welding equipment, motor brushes and SCR's.

**Transverse mode noise**—(Also called differential mode noise). Signals or spikes impressed from line-to-line in a power distribution system.

Complete data on electrostatically shielded transformers is found in Bulletin D-1J.





# SHIELDED ISOLATION TRANSFORMERS

SINGLE PHASE, 60 HERTZ

CLASS 7450

## WIRING DIAGRAMS ③

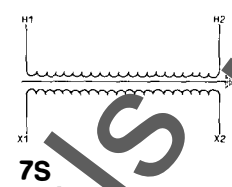
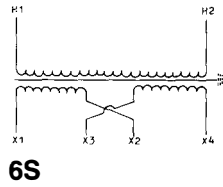
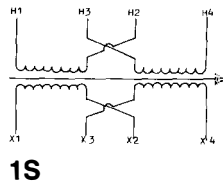

### TO COMPLETE CATALOG NUMBER

To complete the catalog number, select the voltage required from chart below. Insert the voltage code number in place of the ( ) in the catalog number.

Voltage Code	Primary	Secondary	Wiring Diagram
6	120 X 240	120/240	1S
7	208	120/240	6S
8	277	120/240	6S
9	208	208	7S
10	208	240	7S

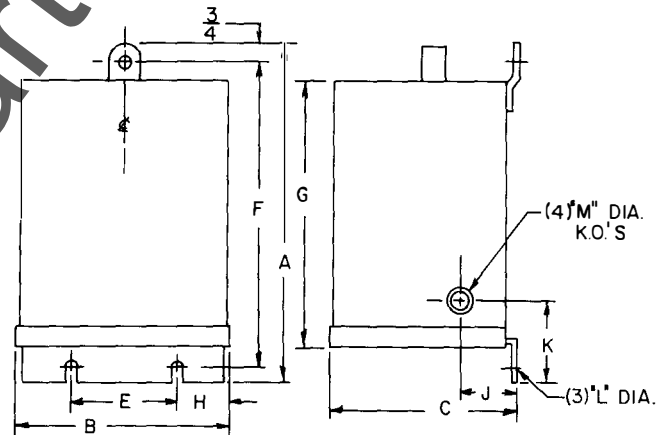
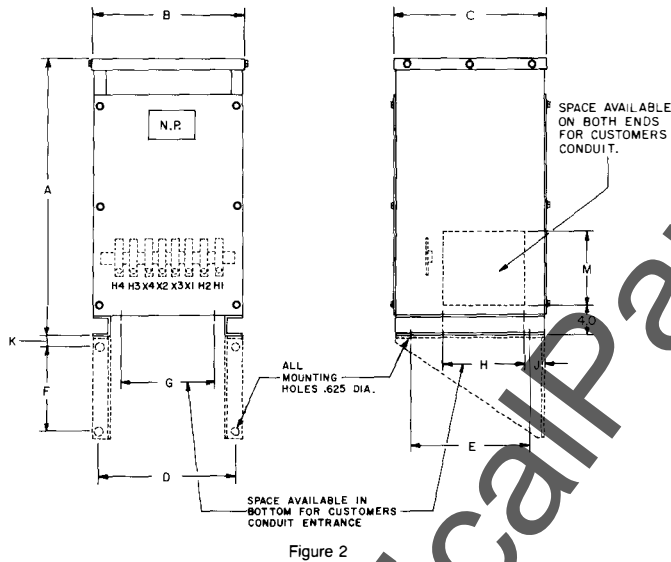

KVA	Cat. No.	Taps	Dimensions In Inches ①													Mounting	Guar. Sound Level	Wgt. Lbs.	Temp. Rise Deg. C	② Av. Z	② Av. X R
			A	B	C	D	E	F	G	H	J	K	L	M	Fig.						
1.5	1.5S( )F1S	None	12.75	6.5	6.25	—	4.0	11.5	10.25	1.25	2.0	2.75	.438	1.13	1	Wall	40	38	115	—	—
2.0	<b>2S( )F1S</b>	None	14.75	8.25	7.5	—	5.0	13.5	12.0	1.63	2.0	2.75	.438	1.13	1	Wall	40	40	115	—	—
3.0	<b>3S( )F1S</b>	None	14.75	8.25	7.5	—	5.0	13.5	12.0	1.63	2.0	2.75	.438	1.13	1	Wall	40	45	115	—	—
5.0	<b>5S( )F1S</b>	None	19.5	10.5	9.5	—	6.0	18.0	16.13	2.25	2.5	3.5	.563	1.38	1	Wall	40	80	115	2.3	.29
7.5	<b>7S( )F1S</b>	None	19.5	10.5	9.5	—	6.0	18.0	16.13	2.25	2.5	3.5	.563	1.38	1	Wall	40	105	115	1.9	.41
10	<b>10S( )F1S</b>	None	19.5	10.5	9.5	—	6.0	18.0	16.13	2.25	2.5	3.5	.563	1.38	1	Wall	45	140	115	1.6	.52
15	15S( )H1S	None	23.0	16.0	15.0	14	11	8	10	4	10	1.125	—	4.5	2	Floor	45	190	150	5.2	.60
25	25S( )H1S	None	23.0	16.0	15.0	14	11	8	10	4	10	1.125	—	4.5	2	Floor	45	230	150	3.9	.74

① Layout drawings are for planning only. Do not use for construction. Contact your local Square D office for certified drawings.

② X and Z values are average only and may vary with design changes. Contact your local Square D office for exact values.

③ Electrostatic shield to be grounded by installer.

Lugs: furnished by customer.

BOLD TYPE Catalog Numbers normally stocked at Central Warehouse and selected Redistribution Centers, voltage codes 6 and 7 only.



**DIMENSIONAL DIAGRAMS**

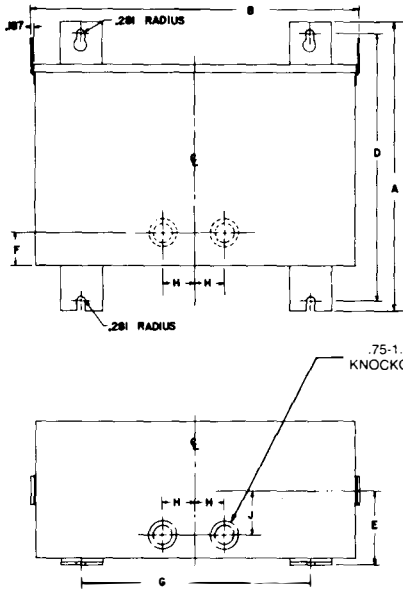

Figure 1

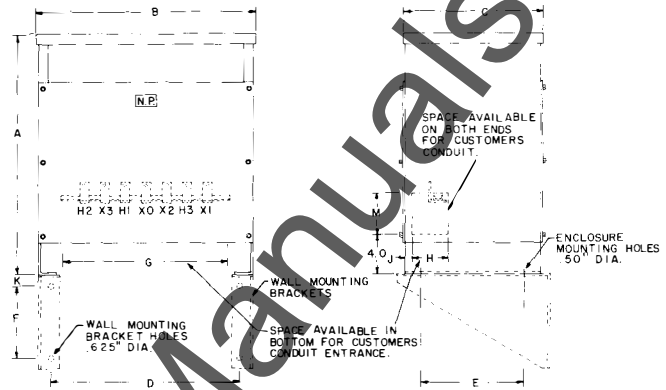
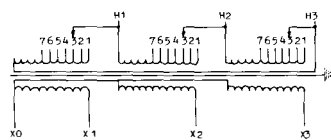
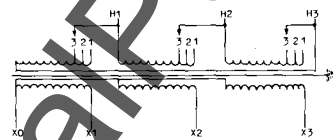

Figure 2

**WIRING DIAGRAMS**



10S



16S

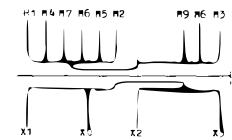

31S

KVA	Catalog Number	Dimensions in inches ①												Wiring Diagram	Guar. Sound Level in DB's	Wgt.	② Ave. % Z	② Ave. X R
		A	B	C	D	E	F	G	H	J	K	M	Fig.					
<b>480 VOLTS DELTA PRIMARY, 208Y/120 VOLTS SECONDARY TWO 5.0% FULL CAPACITY TAPS BELOW NORMAL</b>																		
9	9T2F1S	15.9	16	9.06	14.6	4.63	2.0	9.0	1.87	3	—	—	1	31S	40	160	3.42	.5
<b>480 VOLTS DELTA PRIMARY, 208Y/120 VOLTS SECONDARY SIX 2.5% FULL CAPACITY TAPS, 2+, 4-</b>																		
15	<b>15T3H1S</b>	23	22.25	15	20	11	8	17	4	.625	1.125	4.5	2	10S	45	230	3.6	1.94
30	<b>30T3H1S</b>	23	22.25	15	20	11	8	17	4	.625	1.125	4.5	2	10S	45	285	6.4	.92
45	<b>45T3H1S</b>	26	24	15	22	11	8	18	4	.625	1.125	4.5	2	10S	45	369	6.6	1.13
75	<b>75T3H1S</b>	30	30	20	28	15	11.25	24	9	5.5	1.125	5.0	2	10S	50	590	5.7	1.38
<b>208 VOLTS DELTA PRIMARY, 208Y/120 VOLTS SECONDARY TWO 5% FULL CAPACITY TAPS BELOW NORMAL</b>																		
9	9T85F1S	15.9	16	9.06	14.6	4.63	2.0	9.0	1.87	3	—	—	1	31S	40	160	3.42	5
15	15T85F1S	23	22.25	15	20	11	8	17	4	.625	1.125	4.5	2	16S	45	230	3.6	1.94
30	<b>30T85F1S</b>	23	22.25	15	20	11	8	17	4	.625	1.125	4.5	2	16S	45	285	6.4	.92
45	<b>45T85F1S</b>	26	24	15	22	11	8	18	4	.625	1.125	4.5	2	16S	45	369	6.5	1.13
75	<b>75T85F1S</b>	30	30	20	28	15	11.25	24	9	5.5	1.125	5.0	2	16S	50	590	5.7	1.38

- Layout drawings are for planning only. Do not use for construction. Contact your local Square D office for certified drawings.
- ② X and % Z values are average only and may vary with design changes. Contact your local Square D office for exact values.
- Electrostatic shield to be grounded by installer.

Lugs furnished by customer.

BOLD TYPE Catalog Numbers normally stocked at Central Warehouse and selected Redistribution Centers.