

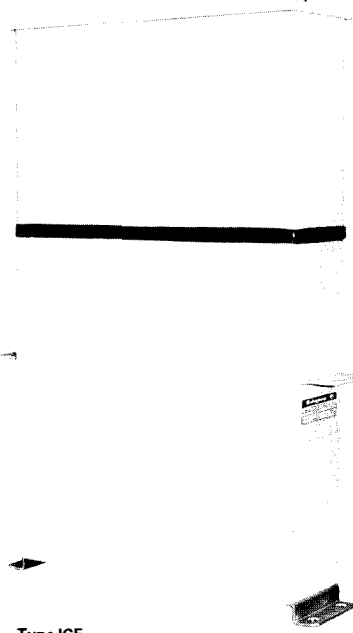

October, 1976
New Information
E, D, C/2001, 2002/DB

Industrial Capacitors



Type ICE



Type MDP



Type HWP

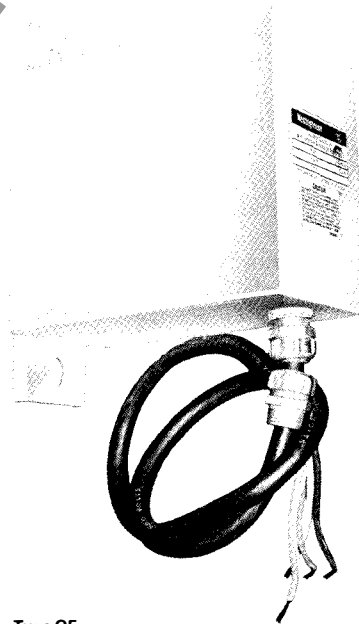

Type OF

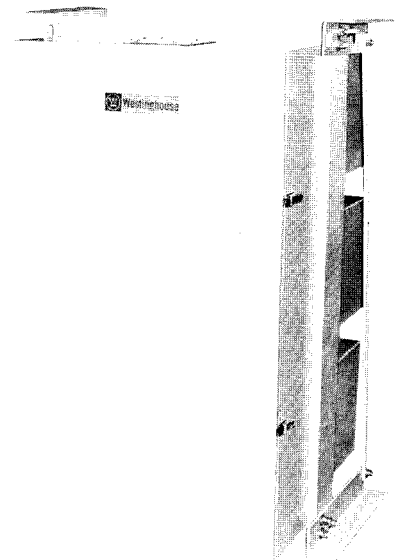

Type MDP - Free Standing

Application

The Westinghouse industrial capacitor designs meet all NEC requirements covering low voltage capacitor installations for power factor improvement in the average industrial plant.

Individual Units – Type ICE – 600 Volts and Below

These individual units provide more corrective capacity near the load when connected directly on machine terminals or at load centers. The units may be located on the load side of the circuit and may be switched "on" or "off" with the load. By switching through the motor or load center controls, separate switches are not required. Such applications also provide semi-automatic control of corrective capacity to avoid overvoltage conditions during light load periods.

Multiple Units – Type MDP – 600 Volts and Below

The multiple capacitor equipments provide for larger amounts of capacity needed at power centers than could be economically obtained through large groups of individual ICE units.

Individual and Multiple Units – Type HWP – 2400 and 4160 Volts

These individual and multiple capacitor equipments provide for corrective capacity at 2400 and 4160 volts near the load or at power centers where larger amounts of capacity are needed.

Advantages

Protection: All industrial capacitor equipment designs:

- protect against entrance of foreign matter such as dust and lint
- isolate live parts from accidental contact
- meets all NEC requirements for low voltage capacitors.

Accessibility: Terminals, fuses and connections are readily accessible upon removal of the terminal enclosure cover.

Flexibility: One or more types of capacitors may be floor or platform mounted or sus-

**Individual Type ICE – Capacitor Equipment
240, 480 and 600 Volts**

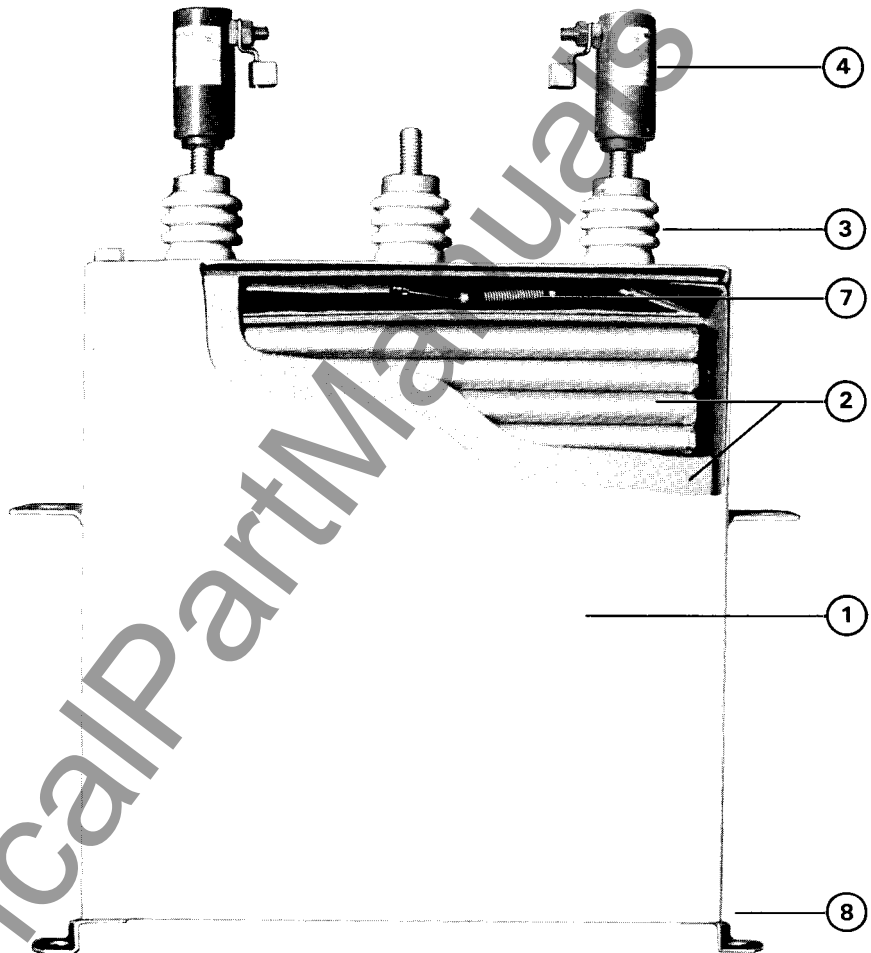

DV Capacitor Unit

ended on mounting brackets from wall or ceiling.

The multiple equipments consist of parallel groups of capacitor units completely assembled and bussed to form a single or multi-tiered assembly having terminals and connections enclosed in a dustproof and weatherproof compartment.

The single-tier type MDP equipments are designed to facilitate mounting of additional tiers of capacitor assemblies in the future, without requiring additional floor space. The additional tiers should have the same unit capacity as the bottom tier.

The capacity of either single or multiple equipments may be increased or decreased by adding or subtracting units, or by substituting units of other ratings as required. When the number of units supplied is less than the total capacity of the tier, dustproof covers are furnished for the vacant openings.

Design Features

(1) Case and Finish of Type DV Capacitor

Case: The case is made from heavy gauge mild steel with all joints welded and reinforced at point of wear. The heavy case protects the working element during handling, shipment and service.

Finish: Enclosures and capacitor units are painted with a primer coat of zinc chromate and a finish coat of acrylic enamel ASA-70 light gray finish. The paint system used assures an attractive and durable outdoor finish.

(2) Working Element

Consists of individual wound sections of special capacitor grade paper, low loss capacitor grade synthetic film, and dead soft aluminum foil. Multiple sections are arranged to yield the specified KVAC at rated voltage. The grouped sections of the working element are insulated from the steel case by means of high purity Kraft insulation material. The unit

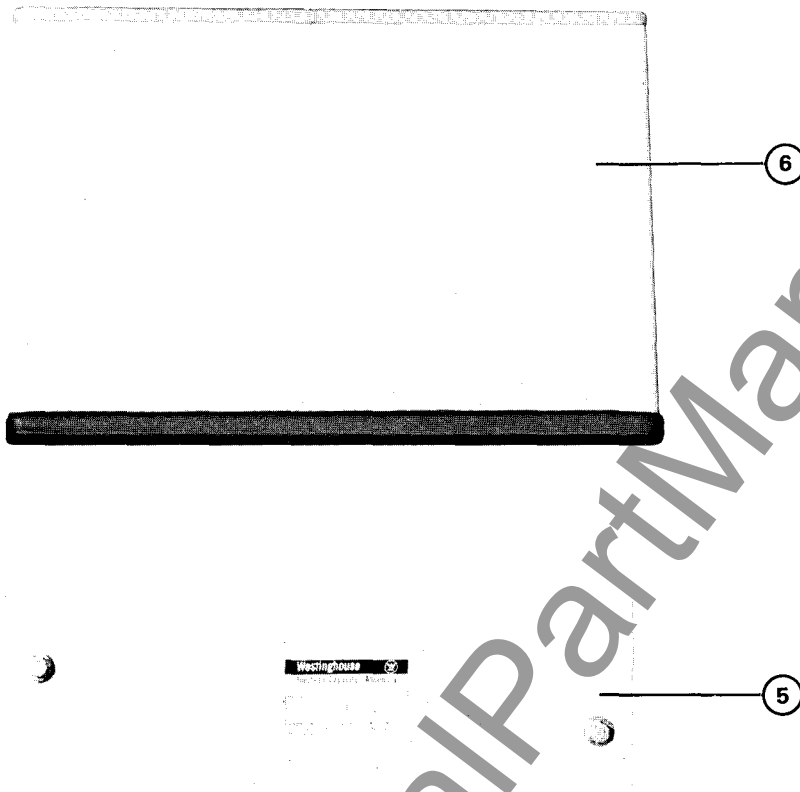

across the terminals of all low voltage capacitor units as a safety measure. Residual voltage is reduced to 50 volts or less within one minute after removal from the energized circuit.

(8) Mounting Provisions

Each type ICE unit is provided with a complete floor mounting kit which bolts into weld nuts at the bottom of each DV capacitor unit. Welded on mounting flanges are provided on each side of the capacitor unit for use in bolting units directly to wall brackets.

Mounting brackets for type ICE capacitor equipments.

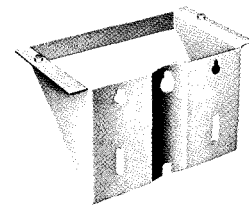

Single Unit Bracket

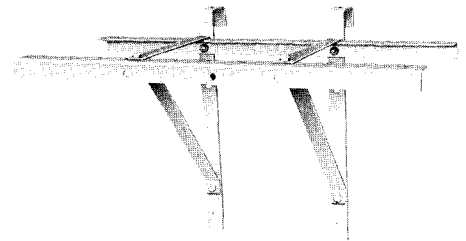

Six Unit Crossarm Bracket

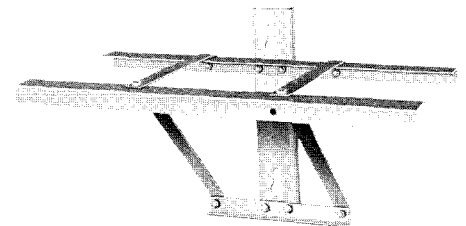

Six Unit Direct Pole Bracket

Bushings - Fuse Enclosure

is vacuum processed and impregnated with a high quality dielectric fluid.

(3) Gland Sealed Bushings

The gland sealed bushing assembly is constructed such that the silicon rubber thick walled gland is compressed between the top cover shoulder, copper stud, and porcelain insulator. This compression seal prevents leakage of dielectric liquid even if the bushing assembly is tilted 15 degrees which could occur during installation of capacitor equipments. The advantage of gland sealing over other types of sealing is that the integrity of the seal is not as dependent on close manufacturing tolerances and errorless assembly procedures.

(4) Individual Indicating Fuses

There are two bushing mounted BAC boric acid fuses or CLC current limiting fuses included with all three phase ICE and MDP capacitor equipments. The interrupting capacity and button or disc type fuse opera-

tion indication assures maximum protection of the capacitor installation. Connection to the BAC fuses is accomplished by means of a screw type connector. Connection to CLC fuses are crimp type rings.

(5) Cover

A bolt on steel cover compresses the top vinyl gasket, thus assuring a dustproof and weatherproof seal between the top cover and the bushing - fuse enclosure.

(6) Bushing - Fuse Enclosure

The bushing - fuse enclosure is formed of 12 gauge mild steel with a neoprene gasket positioned between the enclosure and the capacitor unit. The dustproof and weatherproof enclosure is bolted to the top of the capacitor unit by means of weld nuts and slotted head studs enclosing the bushings, fuses, and connections.

(7) Discharge Resistors

A carbon film resistor is connected internally

Further Information:

Prices: PL 39-210
Dimensions: DS 39-251

Multiple Type MDP Capacitor Equipment
240, 480 and 600 Volts

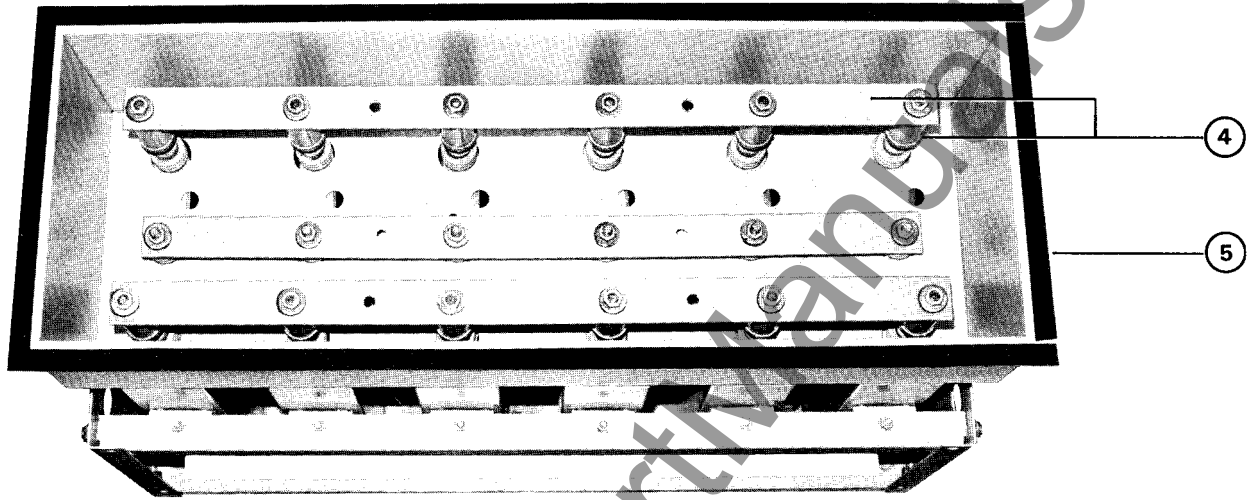

MDP Top View

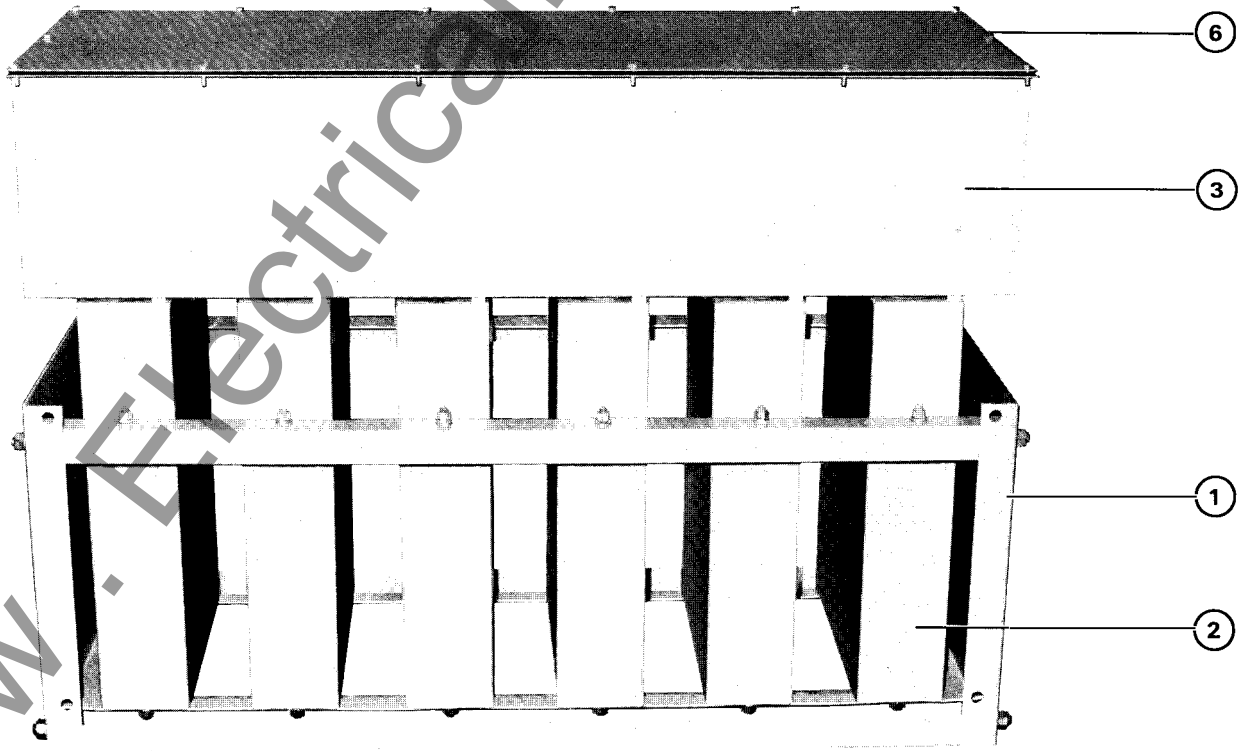

MDP Front View



Selector Guide

KVAC Rating		
240 Volt	480 Volt	600 Volt
2.5	5	7.5
5	7.5	10
7.5	10	15
10	15	20
15	20	25
20	25	30
25	30	35
	35	40
	40	45
	45	50
	50	60
	60	

Design Features

(1) Frame

The capacitor units are supported by a heavy steel, bolted construction frame. Assembled frames used in MDP equipments are painted ASA-70 (light gray) for application either in-door or outdoor.

(2) Individual Capacitors, Type DV

The main component of type MDP equipments is the same capacitor unit used in individual capacitor equipments, type ICE. MDP equipments incorporate all the features of gland sealed bushings, internal discharge resistors, case construction and weather-proof finish. The capacitors are mounted to the frame assembly by bolting the capacitor side brackets to the frame.

(3) Enclosure

All capacitor bushings, terminals, fuses, and connecting bus are enclosed by means of a 12 gauge mild steel enclosure painted ASA-70.

(4) Indicating Fuses and Connections

Each capacitor unit installed has two indicating type CLC current limiting fuses mounted on the capacitor terminals. Connections between capacitor bushings and fuses are completed with aluminum solid bus.

(5) Gaskets

Two sets of neoprene gaskets are installed to assure a weatherproof and dustproof seal. These gaskets are located between each capacitor unit and the bottom of the terminal enclosure; and between the terminal enclosure top and the enclosure cover.

(6) Enclosure Cover

A 12 gauge mild steel bolted-on cover is provided for easy inspection of the fuses and connections.

Further Information:

Prices: PL 39-210

Dimensions: DS 39-251

Selector Guide

KVAC Rating	Capacitor Units (Total Required)
240 Volts	
30	2-15
50	2-25
75	3-25
100	4-25
125	5-25
150	6-25
480 Volts and 600 Volts	
75	1-35, 1-40
100	2-50
125	2-40, 1-45
150	3-50
200	4-50
250	5-50
300	6-50
360	6-60

Multiple Tier MDP Equipments - 240, 480 and 600 Volts

Recommended bank ratings up to 300 KVAC at 240 volts, and 720 KVAC at 480 and 600 volts, may be obtained by stacking individual tiers above one another up to a maximum of three tiers high. The individual tiers are designed to bolt directly together but only tiers of the same unit capacity can be stacked. They are shipped as single tiers, completely wired and assembled.

Installation

Floor Mounting: Single or multiple tier assemblies should be placed in a suitable location and bolted to the floor with the terminal compartment toward the front. Clearance should be allowed at the rear of the assembly to permit removal of the individual capacitor units.

Note: Do not mount the tiers on end.

Wall Mounting:

Single tiers may be bolted directly to the wall with the terminal compartment up. Clearance should be allowed at the bottom of the equipments to permit removal of the individual capacitor units.

Multi-tier wall mounting arrangements require mounting with the terminal cover toward the front. The assembly must be supported from the bottom by a platform bracket (to be supplied by the purchaser). Adequate space must be allowed between the wall and the back of the tiers to permit removal of units.

Ceiling Mounted:

Fig. 2 shows the ceiling mounting arrangement for single tier equipments only. The assembly is suspended from the ceiling by screws, rods, or bolts through the top flange on the ends of the rack. (Suspension rods or straps are to be supplied by the purchaser).

Multi-tier ceiling mounting is not recommended.

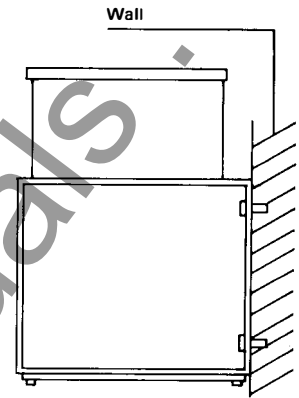

Fig. 1. Wall Mounting, Single Tier

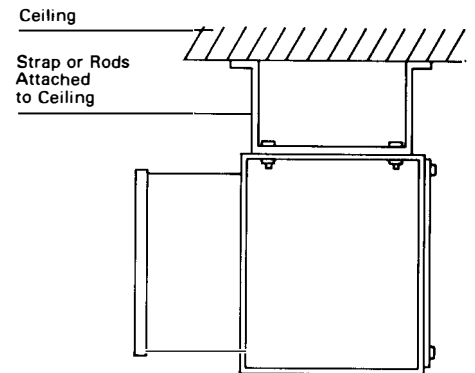

Fig. 2. Ceiling Mounting, Single Tier

Application

The Free-Standing MDP capacitor assembly incorporates all of the salient features of the conventional single-tier MDP into a multi-tier assembly that can be shipped completely assembled, ready to set in place and connect to the purchaser's system.

This equipment is ideally suited for indoor installations requiring up to 50% less floor space than standard MDP stacked units.

Construction

Depending on the capacity required, the assembly provides a choice of either a two or three-tier dustproof frame with a hinged door over the terminal compartment.

Individual terminal mounted indicating type fuses are provided on each capacitor unit, and fuses may be replaced without disassembling the buswork. Standard power entrance is provided by a removable plate on top of the terminal compartment. (Bottom entrance available, if specified.)

The hinged door, suitable for padlocking, isolates all live parts from accidental contact and provides ready access to the terminal compartment for inspection and maintenance.

Mounting

The Free-Standing MDP assembly is designed for floor mounting only; and lifting eyes are furnished with the equipment.

Ratings

Recommended bank ratings up to 300 KVAR at 240 volts, and 720 KVAR at 480 and 600 volts may be obtained by utilization of its 8 and 12 unit basic enclosures. When the equipments are shipped with less than a full component of capacitor units, cover plates are installed over the back panel openings to allow for future installation and upgrading of the equipment with the addition of capacitor units, fuses and bus connections.

Intermediate Ratings

Intermediate ratings not listed in the selector guide may be obtained by omitting units or substituting units of smaller KVAR ratings. (For pricing, refer to Westinghouse.) When the number of individual units supplied is less than the total capacity of the tier, dustproof steel covers are furnished for the vacant openings. When individual units of lower KVAR ratings are included, adapters are supplied for accommodating mounting the units within the assembly.

Frame

A heavy frame of welded and bolted construction, jig fabricated to assure proper alignment, supports the capacitor units and provides spacing to insure proper ventilation. Lifting eyes are an integral part of the frame.

Individual Capacitor, Type DV

The basic unit of multiple dustproof equipments is the same capacitor unit as used in the individual dustproof equipments and incorporates all the features of gland sealed bushings, internal discharge resistors, case

Multiple Type MDP – Free Standing

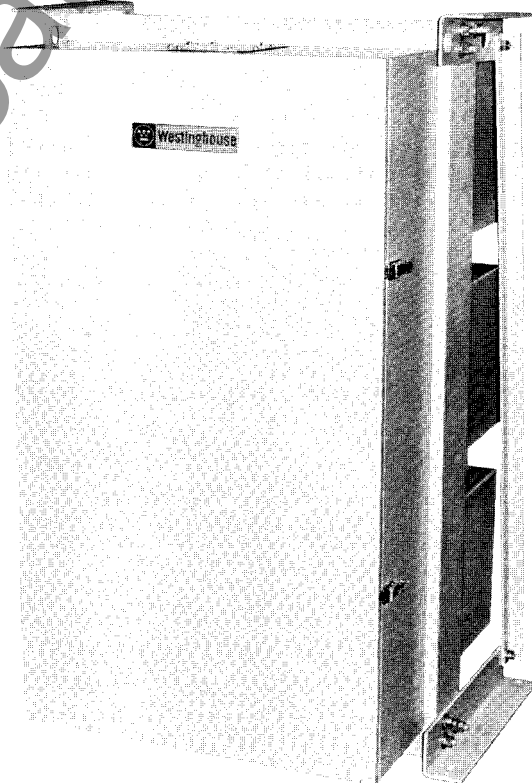
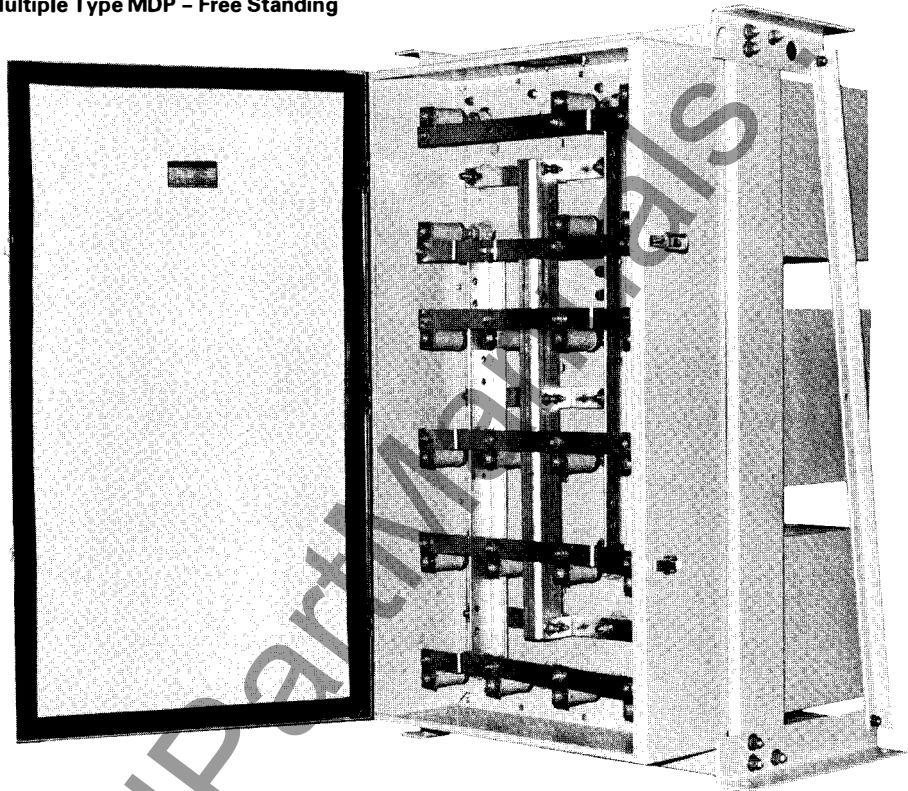

12 Unit – Type MDP Free Standing



construction and weatherproof finish. The units are mounted on edge by means of weld nuts and studs with the terminals projecting through a sheet steel panel of the bolted frame assembly.

Enclosure

A single wrap-around enclosure is bolted to the sheet metal panel of the frame assembly, enclosing the terminals, fuses and connections of the capacitor units. A hinged door with draw pull type latches gives excellent accessibility to the fuses, interconnecting buswork and cable terminals. Facility for padlocking is a part of the latch mechanism.

Finish

Enclosures and capacitor units are finished with two coats of outdoor light gray ASA-70 enamel which is attractive and durable – also provides high resistance to abrasion.

Conduit Entrance

Standard conduit entrance can be accommodated from above by means of a removable plate in the top of the terminal compartment. (Bottom entrance available if specified.)

Indicating Fuses and Connectors

Individual unit type CLC current limiting fuses are mounted on the capacitor terminals. Connections between the units are completed with aluminum solid bus.

Gaskets

Three sets of neoprene gaskets are provided to complete the seal of the enclosed terminal chamber. These are located: 1. Between each capacitor unit and the back enclosure panel, 2. Between the back enclosure panel and the sides of the terminal enclosure, and 3. Around the inside of the front hinged door that bears against the enclosure sides.

Type OF

Westinghouse type OF, unfused, capacitor units are designed for outdoor or indoor application on 3 phase, 480 volt power distribution systems. Compact design in a wide range of ratings up to 60 KVAC make them ideal for power factor improvement on small isolated oil field or irrigation pumping installations. Applied on the load side of a fused motor starter, they do not require a separate switch or fuse contained within the capacitor. This results in minimum installed cost per KVAC.

Design Features

Type OF capacitors have an aluminum case for permanent protection against corrosion and weather. Mounting brackets attached to the case permit easy installation on flat or pole mounting surfaces. The unit includes a 48 inch, 4 conductor neoprene cable for connections to the fused motor starter. Water-tight bushings are provided on each end of the cable and are removable when installed with conduit.

Selector Guide

Free-Standing Capacitor Equipment – 8 Unit or 12 Unit Size

Rating KVAC		Capacitor Units (Total Required)
240 Volts		
40	8 unit	2-20 KVAC
50	Cabinet	2-25 KVAC
60		3-20 KVAC
75		3-25 KVAC
80		4-20 KVAC
100		4-25 KVAC
125		5-25 KVAC
150		6-25 KVAC
175		7-25 KVAC
200		8-25 KVAC
480 Volts and 600 Volts		
225	12 unit	9-25 KVAC
250	Cabinet	10-25 KVAC
275		11-25 KVAC
300		12-25 KVAC
100	8 unit	2-50 KVAC
150	Cabinet	3-50 KVAC
200		4-50 KVAC
250		5-50 KVAC
300		6-50 KVAC
350		7-50 KVAC
400		8-50 KVAC
480		8-60 KVAC
450	12 unit	9-50 KVAC
500	Cabinet	10-50 KVAC
550		11-50 KVAC
600		12-50 KVAC
720		12-60 KVAC

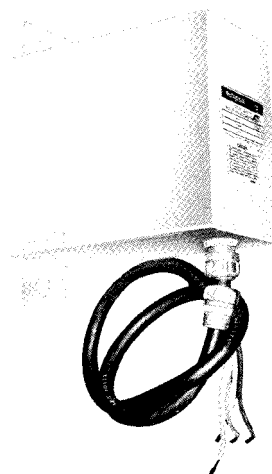

Selector Guide

KVAC Ratings	
480 Volts	
2	
3	
4	
5	
6	
10	
15	
20	
25	
30	
35	
40	
45	
50	
60	

Further Information:

Prices: PL 39-210

Dimensions: DS 39-251



Type HWP – 2400 and 4160 Volts

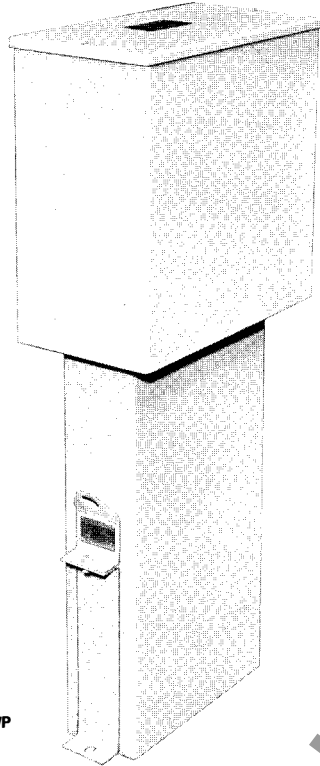

One Unit Type HWP

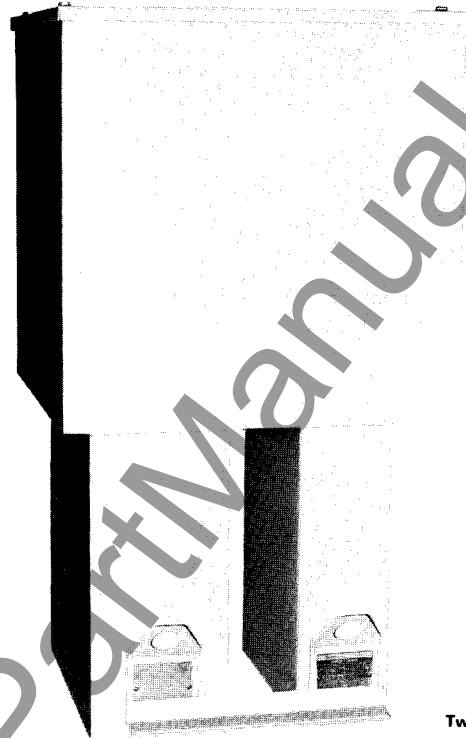

Two Unit Type HWP

Design Features

Individual Capacitor, Type DV

The main component of HWP capacitor equipments is the type DV capacitor. This unit incorporates all the features of gland sealed bushings, internal discharge resistors, case construction and weatherproof finish as used and described in the type ICE equipments.

Enclosure

All capacitor bushings, terminals, fuses, and connecting bus (2 unit only) are enclosed by means of a wrap around 12 gauge mild steel enclosure painted ASA-70.

Indicating Fuses and Connectors

Each three phase capacitor unit installed has two indicating type CLC current limiting fuses mounted on the capacitor terminals. Connections between capacitor bushings (2 unit only) and fuses are made with aluminum solid bus.

Gaskets

Two sets of neoprene gaskets are installed to assure a weatherproof and dustproof seal. These gaskets are located between each capacitor unit and the bottom of the terminal enclosure; and between the terminal enclosure top and the enclosure cover.

Enclosure Cover

A 12 gauge mild steel bolted on painted cover is provided for easy removal and inspection of the fuses and connections.

Mounting Provisions

Each type HWP capacitor equipment is supplied with floor mounting brackets. On two unit equipments a support tie bracket is also provided between the capacitor units.

Further Information:

Prices: PL 39-210
Dimensions: DS 39-251

Selector Guide

KVAC Ratings	Capacitor Units (Total Required)
2400 and 4160 Volts	
25	1-25
50	1-50
75	1-25, 1-50
100	1-100
125	1-25, 1-100
150	1-150
175	1-25, 1-150
200	1-200
225	1-25, 1-200
250	1-50, 1-200
300	2-150
350	1-150, 1-200
400	2-200

Printed in U.S.A.