

FEEDBACK AND VOLTAGE CONDITIONING PANEL

Ref. 3594C13

1. Feedback Circuit consists of a three phase isolation transformer that reduces the voltage to the logic signal level and is rectified.

The resulting DC voltage is proportional to the inverter output so that a one percent increase in inverter output voltage results in a one percent increase in the DC feedback voltage at terminals VCF and COM. This voltage is fed via terminals VCF and COM of the logic drawer, to terminals L18 and U5 of the voltage regulator board 663C779. The operation of the voltage regulator board is described in another section of this service manual.

2. Voltage Dropping Circuit - Provides a means of using a standard logic power supply which has a design operating range of 175 volts DC to 320 volts DC. Components 1C, 1R, 1D and 2D are used with a single power supply (S# 3466D30G01). Components 2C, 3D and 4D are added when a dual logic power supply (S# 3466D30G02) is used in inverters having 10 or more power stages. This circuit provides a constant voltage drop of 55 to 65 volts DC across terminals (-) and 1(-) to allow the logic power supplies to operate within a voltage range of 240 volts to 385 volts DC. The extra components used for the dual supply provides the same voltage drop at a higher current.
3. Paralleling Control Circuit Consists of relays SNR, PRR and BFR (optional relays BFRA and LFR).

"SNR" - is an electrically operated, magnetically latched relay which connects the master pulse generator signal from terminal 53 to the inverter synchronizing board (V12) thru terminals syn. A second contact completes the voltage regulator reference voltage to the voltage regulator board (L3) via terminals RR. These contacts will remain closed until the relay is electrically released. A coil failure would not prohibit continued parallel operation.

"PRR" - is an electrically operated relay actuated by an electrical interlock on the main AC output contactor (or motor operated breaker). One contact completes the regulator reference (RR) signal from other inverters in the system thru terminal 54. A pair of contacts complete the voltage regulator output (RO) and input (RI) signal tie to the error restrictor diode circuit thru terminals 57 and 56.

"BFR" - Control relay is actuated by blown fuse contacts in power drawers or external indicator fuses. (Refer to main system schematic for additional contacts in circuit.) Output contacts are used for:

1. Disconnect AC output contactor (or trip motor operated breaker) to isolate a faulty inverter from a UPS bus.
2. Provide signal contact for alarms.
3. Initiate complete sequential shutdown of inverter.

"BFRA" (If used) - Auxiliary "BFR" relay is used when additional contacts are required.

"LFR" (If used) - Fail safe control relay energized by a separate 24 volt DC power supply. Output contacts are used in circuits similar to "BFR" relay except relay de-energizes when a failure occurs in the inverter logic power supply.

4. Error Restrictor Circuit acts as a clamp on voltage regulator signals of all the inverters in parallel, assuring that the conduction angles and hence, the output voltages of the individual inverters, are within very close limits. One complete circuit consisting of diodes 11D to 40D and potentiometers 1P to 6P is provided with each six-inverter system. Potentiometers are set during startup to compensate for voltage drop across wires connected to other voltage regulators in the UPS system.

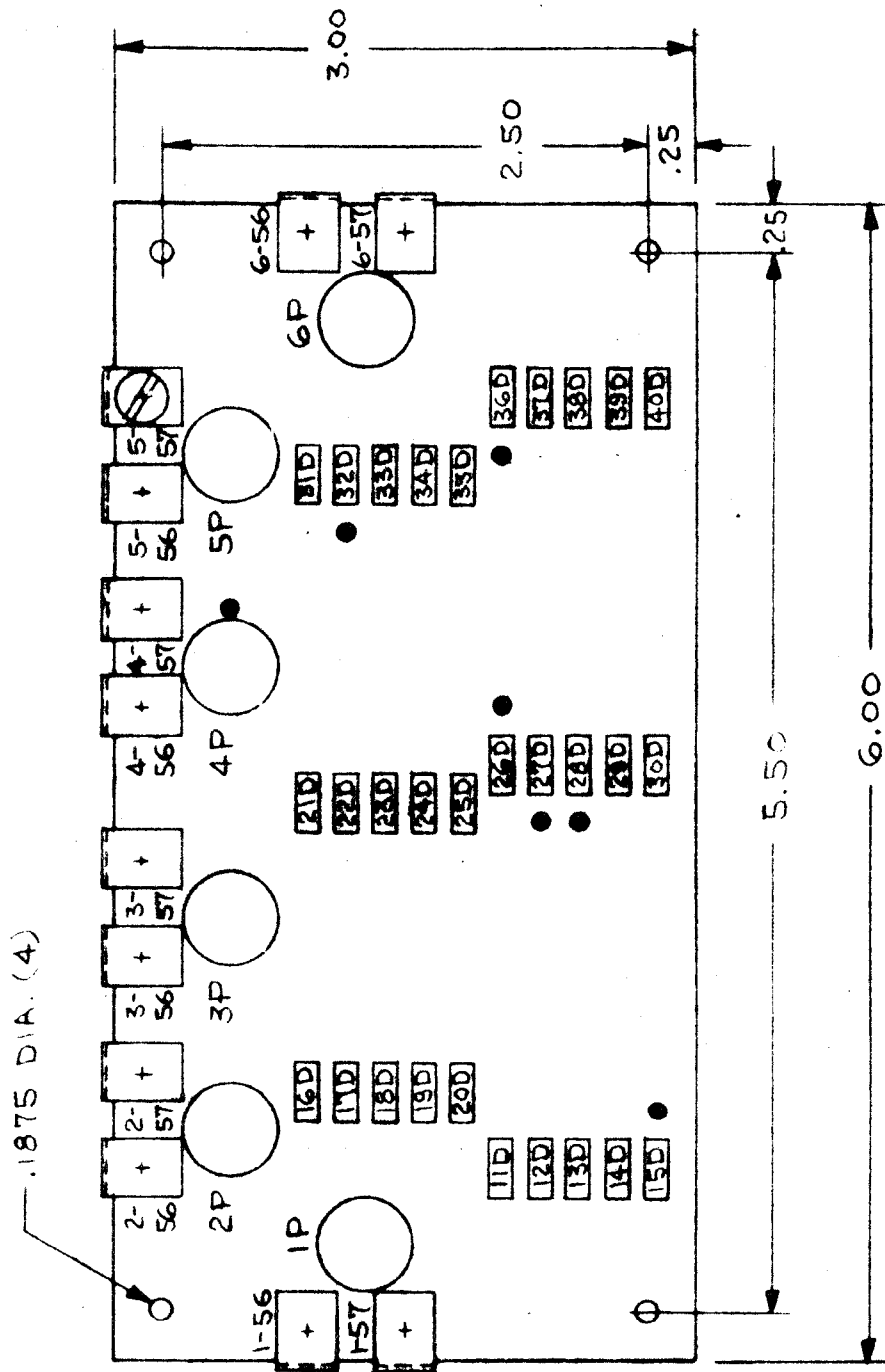

Error Restrictor Circuit Card  
Component Layout

Dwg 3594C13 SUB 1

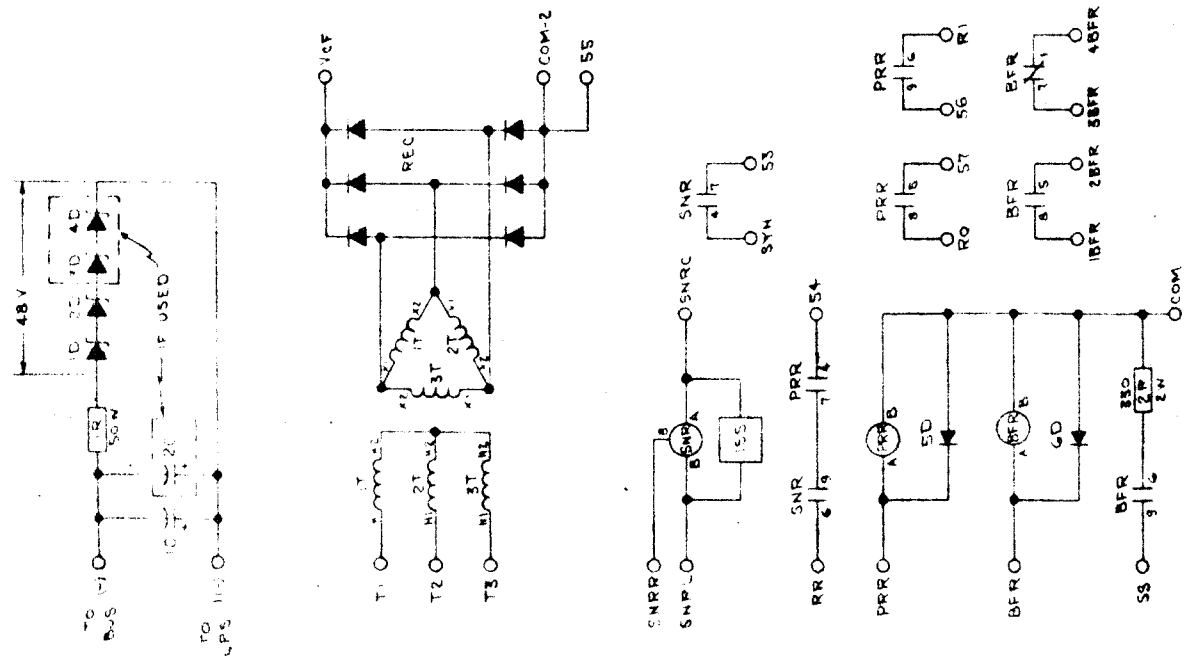

WESTINGHOUSE ELECTRIC CORPORATION	
TITLE FEEDBACK VOLTAGE CONDITIONING PANEL	
DIMENSIONS IN INCHES - SCALE	
DWG NO. 3594C13	APP'D [Signature]
REV	DATE
BY	PLANT LOCATION
01	5

3594C13	
DRAWING NUMBER 3594C13	
DATE 10-15-54	
BY 10-15-54	
PLANT LOCATION 15D EPC	
01	
5	